

Fig. 817.PF
Bronze Strainer



FEATURES & BENEFITS

- Strainer complete with Press-Fit connectors
- Helps prevent damage to pipeline equipment caused by scale and dirt
- Supplied as one integral unit means less joints to make on-site
- The performance, exact dimensions and tolerances are known in advance
- Incorporates both Hattersley and proven Geberit Mapress technology
- Vibration tested to DVGW and bend tested to BS EN331
- Quickly and easily installed using a Press-Fit tool (supplied by others)

MATERIAL SPECIFICATION

No.	Component	Material	Specification
1	Body	Bronze	BS EN 1982 CC491K
2	Mesh	Stainless Steel	AISI Type 304
3	Cap Seal	PTFE	WRAS Approved
4	Cap	Bronze	BS EN 1982 CC491K
5	Press-Fit Connector	Bronze	BS EN 1982 CC499K
6	Joint O-Ring	EPDM Rubber	WRAS Approved
7	Connector O-Ring	CIIR Butyl Rubber	WRAS Approved

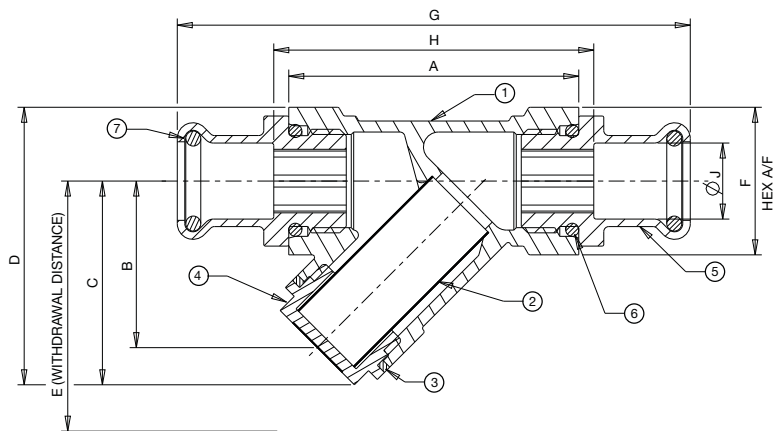

Fig. 817.PF



Fig. 817.PF Pressed

DIMENSIONAL DRAWING



DIMENSIONS & WEIGHTS

Size (mm)	Dimensions (mm)										Weight (Kg)
	Mesh Hole Ø	A	B	C	D	E	F	G	H	ØJ	
1/2 x 15	0.75	58	33	40	55	62	27	103	63	15	0.284
1/2 x 18	0.75	58	33	40	55	62	27	104	64	18	0.290
3/4 x 22	0.75	70	42	54	69	80	33	121	80	22	0.443
1 x 28	0.75	88	48	60	80	93	40	140	95	28	0.612
1 1/4 x 35	1.40	96	55	69	95	108	49	154	103	35	1.064
1 1/2 x 42	1.40	107	61	76	107	118	55	175	117	42	1.416
2 x 54	1.40	126	79	99	135	153	67	207	138	54	2.030

TEMPERATURE RANGE

-10 to 120°C

SPECIFICATION

Bronze (BS EN 1982 CC491K) 'Y' type Strainer. Fitted with perforated stainless steel screen with 0.75mm holes (1/2" to 1") and 1.40mm holes (1 1/4" to 2"). Machined screen seats in body and cap ends. Screwed-in cap with captive washer. Complete with Geberit Mapress bronze Press-Fit adaptors Rated PN16 (Maximum temperature 120°C).

Every effort has been made to ensure that the information contained in this publication is accurate at the time of publishing. Hattersley Ltd assumes no responsibility or liability for typographical errors or omissions or for any misinterpretation of the information within the publication and reserves the right to change without notice.

0813_V3