

Fig.2900 & 2910 Thermal Circulation Valves



FEATURES AND BENEFITS

- Ideal for domestic hot water services to assist with protection against Legionella
- Provides self-balancing, thermostatically controlled regulation of flow and disinfection
- Thermal disinfection at temperatures above 70°C
- Compact unit comprising isolation valve with thermometer access point
- Incorporates a settable temperature sensing cartridge, factory pre-set at a standard 57°C
- Has an accuracy of +/- 2°C at set temperature

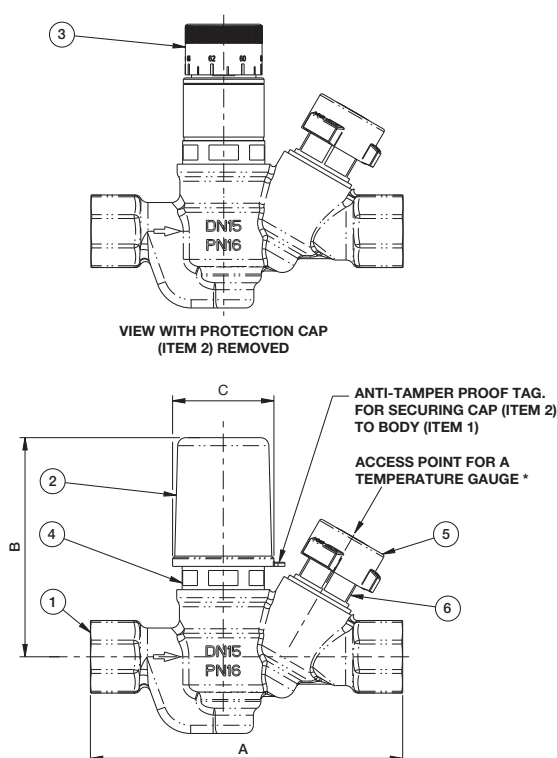

Fig.2900

MATERIAL

No.	Component	Material	Specification
1	Body	Bronze	BS EN 1982 CC491K
2	Protective Cap (Removable)	Polypropylene	-
3	Temperature Adjusting Cap	Nylon 6	-
4	Bonnet and Associated Parts	DZR Brass	BS EN 12164 CW602N
5	Handwheel	Nylon 6	-
6	Bonnet	DZR Brass	BS EN 12164 CW602N
INT	Stem	Stainless Steel	SS EN10088-3 1.4305
INT	Body Seat	DZR Brass	BS EN 12164 CW602N
INT	Plug	DZR Brass	BS EN 12164 CW602N
INT	Bush	DZR Brass	BS EN 12164 CW602N
INT	O-Ring Seals	EPDM Rubber	WRAS Approved
INT	Stem	DZR Brass	BS EN 12164 CW602N
INT	Body Seat	PTFE	WRAS Approved
INT	Stem Seat Retainer	DZR Brass	BS EN 12164 CW602N
INT	O-Ring Seals	EPDM Rubber	WRAS Approved

DIMENSIONAL DRAWING



DIMENSIONS AND WEIGHTS

Size (DN)	Fig. No	Flow	A (mm)	B (mm)	C (mm)	Female End Connections	Weight (kg)
15*	2910	Low	114	80	37	Pipe Thread EN 10226 Rc 1/2"	0.76
15*	2900	Standard	114	80	37	Pipe Thread EN 10226 Rc 1/2"	0.76
20*	2900	Standard	126	80	37	Pipe Thread EN 10226 Rc 3/4"	0.88

*Thermometer fits all sizes. Available on request

PRESSURE RATING PN16 TEMPERATURE RATING Max. 90°C

OPERATION When the set point is preset to 57°C, the valve remains completely open up to a valve temperature of 52°C. Between 52°C and the set point of 57°C, the valve starts to close. When the set point temperature has been reached, a minimum volume flow is continuously flowing through the circulation system. If the storage temperature is further increased to temperatures greater than 70°C to effect disinfection, the valve increases the flow.

SPECIFICATION Taper threaded to BS EN 10226-2

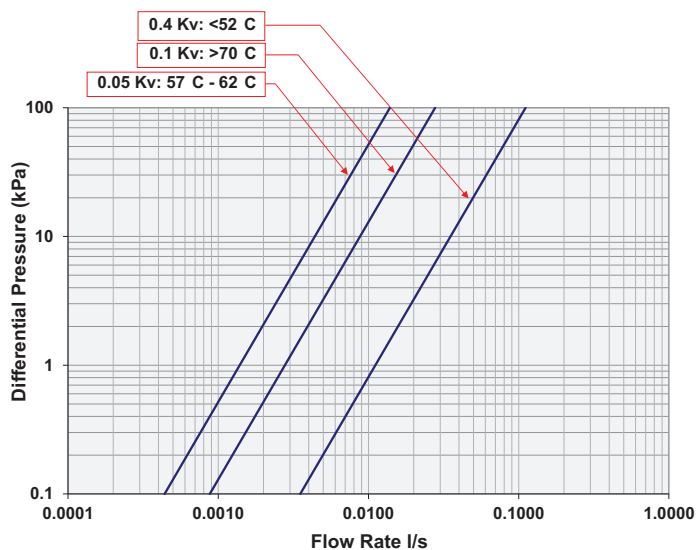

Fig.2900 | 2910 Performance & Flow Charts

The charts on this page show performance characteristics of each valve size at various temperatures.

- At initial installation and start up, and with system temperature below the valve set point of 57°C, the valves are fully open allowing a higher flow rate through the valves.
- As the system temperature increases, the valve will partially close until it reaches the set point of 57°C. At this temperature the valve will remain static and slightly open to allow a continuous flow of fluid. This is critical to avoid dead-legs with stagnant water in the system.
- Thermal Disinfection is best achieved at higher temperatures and fully effective at 70°C. Our valves have been designed such that the flow through the valves increases during the disinfection process.
- Graphs show the relationship between flow rate (l/s) and differential pressure (kPa) for the 3 operating positions of the TCV. As the TCV responds to a change in water temperature the flow coefficient (Kv) changes. The differential pressure created by an individual flow rate can be read off the graph using the relevant temperature line.

DN15 LOW FLOW Set Position 57°C



DN15 STANDARD FLOW Set Position 57°C

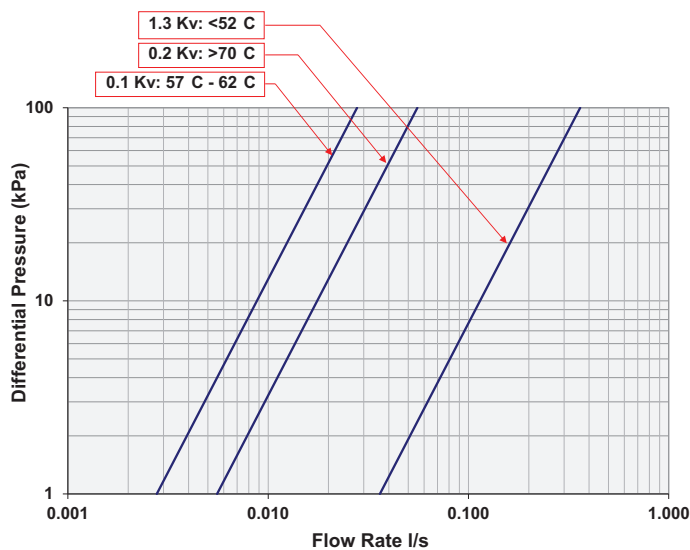

DN20 STANDARD FLOW Set Position 57°C

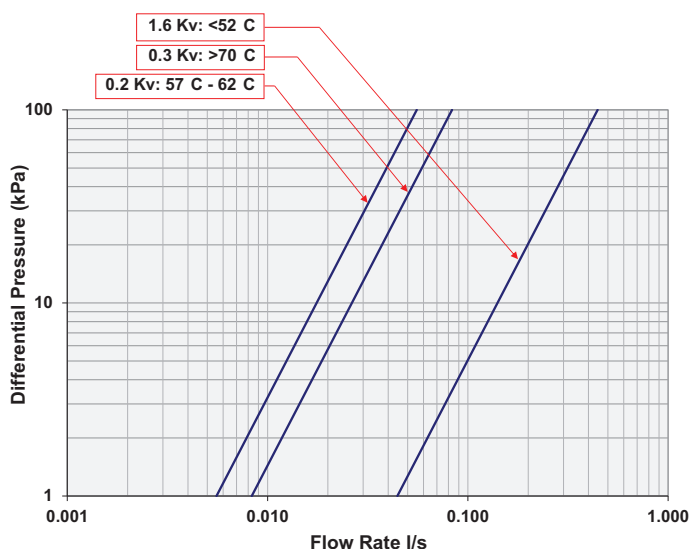

THERMAL REGULATION RESPONSE*

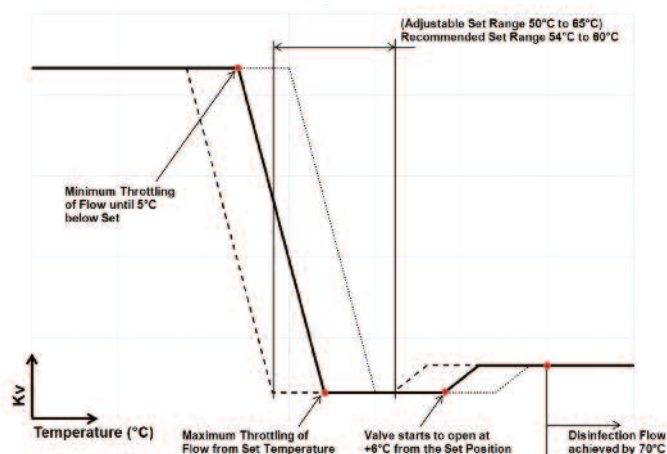

* The performance chart above indicates the shift in thermal reaction when the temperature set point of 57°C is altered.



PO BOX 719, IPSWICH, IP1 9DU
HOME SALES: +44 (0)1744 458670
EXPORT SALES: +44 (0)1744 458671
TECHNICAL HELPLINE: 0845 604 1790

FAX: +44 (0)1744 26912
EMAIL: uksales@hattersley.com
EMAIL: export@hattersley.com
www.hattersley.com

H_TCV_0913

Every effort has been made to ensure that the information contained in this publication is accurate at the time of publishing. Hattersley assumes no responsibility or liability for typographical errors or omissions or for any misinterpretation of the information within the publication and reserves the right to change without notice.