

- COMMISSIONING**
- The Hattersley TCV is factory set at 57°C, and should not require adjustment. However, if necessary, the set temperature can be adjusted as follows:
 - Ensure that the isolation valve (1) is fully open
 - Remove protective cover (2) as shown
 - Turn adjusting cap (3) clockwise to the dead stop (50°C) position. Then, re-open anti-clockwise to selected desired temperature.
 - Replace protective cap (2)
 - A security tab is provided on the protective cover (4) to enable securing of cover to prevent adjustment of temperature setting.

- LIMITS OF USE**
- These installation, operating and maintenance instructions have been categorised in accordance with the Pressure Equipment Directive – PED.
- The fluid to be transported is limited to Group 2 liquids i.e. non-hazardous. On no account must these valves be used on any Group 1 liquids, Group 1 gases or Group 2 gases.**
- INSTALLATION**
- Hattersley products are designed for installation and use within suitably designed systems reflecting CIBSE, BSRIA and HVAC guidelines. Particular care should be taken with regards to:
 - Accessibility to valve - for setting and measuring temperature
 - Joining - ensure that joints are clean and no debris enters the valve
 - Tube cutting - ensure that burrs are removed from cut pipe
 - Bracketting / supports - should be adequate for weight of valve and pipe
 - System cleanliness - the system should be clean and free from debris which could enter valve ports and reduce flow - we recommend that strainers are fitted to protect valves and other installed equipment.
 - The TCV must be installed in the return pipework
 - The valve must be installed so that the flow through the valve follows the flow direction arrow on the valve body
 - Valves should be installed in pipework of the same nominal diameter
 - Valves can be installed in any orientation
 - End connections are internal taper threaded to BSEN 10226-2



Thermal Circulation Valve (TCV)

Fig. 2900 Standard Flow - DN15 & DN20
Fig. 2910 Low Flow - DN15

THE HATTERSLEY TCV

- Is a self-acting temperature control valve designed to ensure that Domestic Hot Water Service (DHWS) systems always have a flow of water.
- Ensures that water in the system is maintained at a high temperature, so that legionella is unable to survive.
- Provides thermal balance across the system.
- Has temperature verification port as standard.
- Has integral isolating valve as standard.



TECHNICAL

- Adjustable control range: 50°C to 65°C
- Max recommended control range: 54°C to 60°C
- Factory pre-setting: 57°C
- Temperature for thermal disinfection: 70°C
- Max temperature: 90°C
- Control accuracy: +/- 2°C
- Pressure rating: PN16
- End connections are internal taper threaded to BSEN 10226-2



PO BOX 719, IPSWICH, IP1 9DU
HOME SALES: +44 (0) 1744 458670
EXPORT SALES: +44 (0)1744 458671
TECHNICAL HELPLINE: 0845 604 1790

FAX: +44 (0)1744 26912
EMAIL: uksales@hattersley.com
EMAIL: exportsales@hattersley.com

www.hattersley.com

- Designed and manufactured under quality management systems in accordance with BS EN ISO 9001-2008

Every effort has been made to ensure that the information contained in this publication is accurate at the time of publishing. Hattersley assumes no responsibility or liability for typographical errors or omissions or for any misinterpretation of the information within the publication and reserves the right to change without notice.

H.TCV_0413 IOM_004B02900D799_v1

ISOLATION

To assist with maintenance of system, an integral isolation valve is provided on every TCV.

- During normal operation, the isolation valve must be fully open.
- To isolate, turn the handwheel clockwise until a firm stop is achieved.
- Re-open the valve by turning the handwheel anti-clockwise until a firm stop is achieved.

TEMPERATURE VERIFICATION

It is recommended that a log book is maintained on site with a record of temperatures for each valve listed, and that regular temperature checks are made and recorded.

To check temperature:

- Lift cap (1) in cover of isolation valve to gain access to thermometer recess
- Insert thermometer (2)
- Allow temperature to settle and then record temperature
- Remove thermometer (2) and re-fit cap (1)

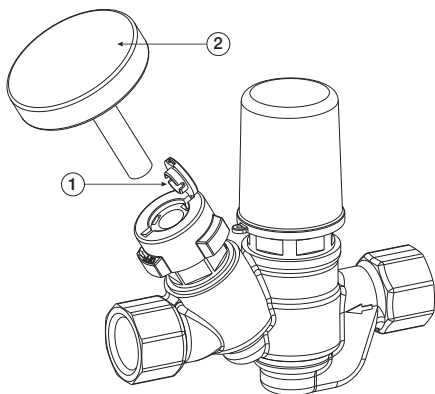

CAUTION

The temperature probe will be hot and care should be taken to avoid burning / scalding.

PERFORMANCE CHART

The performance chart below indicates the shift in thermal reaction when the temperature set point of 57°C is altered.



RANGE

- Fig. 2900 Standard Flow - DN15 (Part No: 004B02900JW)
- Fig. 2900 Standard Flow - DN20 (Part No: 006B02900JW)
- Fig. 2910 Low Flow - DN15 (Part No: 004B02910JWAPA)

ACCESSORIES & SPARE PARTS

- Thermometer for all sizes - (Part No 000TH2900JW)
- Protective Cap for all sizes - (Part No 000PC2900JW)

FLOW CHARTS

The charts below show performance characteristics of each valve size at various temperatures.

- At initial installation and start up, and with system temperature below the valve set point of 57°C, the valves are fully open allowing a higher flow rate through the valves.
- As the system temperature increases, the valve will partially close until it reaches the set point of 57°C. At this temperature the valve will remain static, and slightly open to allow a continuous flow of fluid. This is critical to avoid dead-legs in system.
- Thermal disinfection is identified as a means of controlling Legionella in the HSE L8 Approved Code Of Practise (ACOP). Thermal disinfection is best achieved at higher temperatures and fully effective at 70°C. Our valves have been designed such that the flow through the valves increases during the disinfection process.
- Graphs show the relationship between flow rate (l/s) and differential pressure (kPa) for the 3 operating positions of the TCV. As the TCV responds to a change in water temperature the flow coefficient (Kv) changes. The differential pressure created by an individual flow rate can be read off the graph using the relevant temperature line.

