



Fig. 1732.PF Bronze Fixed Orifice Double Regulating Valve



FEATURES & BENEFITS

- Fixed Orifice Double regulating valve complete with Press-Fit connectors
- Provides precise and accurate flow regulation & measurement
- Supplied as one integral unit means less joints to make on-site
- The performance, exact dimensions and tolerances are known in advance
- Incorporates both Hattersley and proven Geberit Mapress technology
- Vibration tested to DVGW and bend tested to BS EN331
- Quickly and easily installed using a Press-Fit tool (supplied by others)

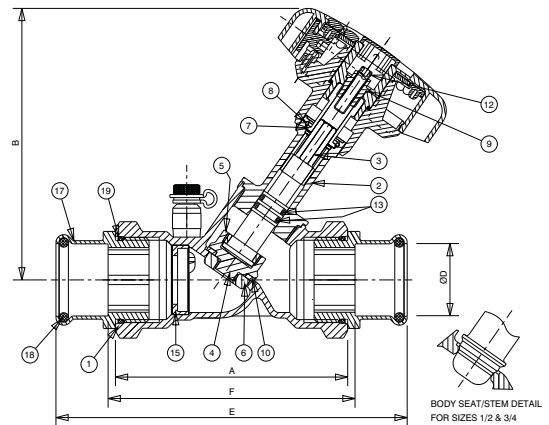
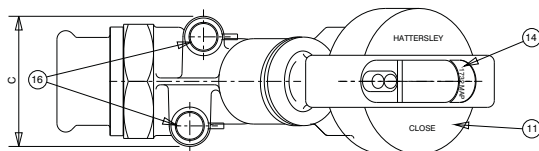

Fig. 1732.PF

MATERIAL SPECIFICATION

No.	Component	Material	Specification
1	Body	Bronze	BS EN 1982 CC491K
2	Bonnet - 1/2" - 1 1/4"	DZR Brass	BS EN 12165 CW602N
	Bonnet - 1 1/2" - 2"	Bronze	BS EN 1982 CC491K
3	Stem	DZR Brass	BS EN 12165 CW602N
4	Disc (Sizes 1-2" only)	DZR Brass	BS EN 12165 CW602N
5	Disc Retaining Ring (Sizes 1-2" only)	DZR Brass	BS EN 12165 CW602N
6	Balancing Cone	DZR Brass	BS EN 12165 CW602N
7	Drive Sleeve	Brass	BS EN 12164 CW617N
8	Drive Sleeve Retaining Clip	Carbon Spring Steel	DIN7993 SIZE 018
9	Handwheel Retaining Screw	Brass	BS EN 12164 CW617N
10	Disc Face (Sizes 1-2" only)	PTFE	WRAS Approved
11	Hattersley Handwheel	Plastic	-
12	Memory Stop Screw	HT Steel	-
13	O-Ring Seal	EPDM Rubber	WRAS Approved
14	Identification Plate	Polycarbonate	-
15	Orifice Insert	DZR Brass	BS EN 12164 CW602N
16	Fig. 631 Press Test Valve	DZR Brass	BS EN 12164 CW602N
17	Press-Fit Connector	Bronze	BS EN 1982 CC499K
18	Connector O-Ring	CIIR Butyl Rubber	WRAS Approved
19	Joint O-Ring	EPDM Rubber	WRAS Approved

DIMENSIONAL DRAWINGS



DIMENSIONS & WEIGHTS

Fig. No.	Size (mm)	Dimensions (mm)						Weight (Kg)
		A	B	C	ØD	E	F	
Fig.1732.PF	1/2 x 15	87	110	46	15	132	93	0.716
Fig.1732L.PF	1/2 x 18	87	110	46	18	133	94	0.720
Fig.1732.PF	3/4 x 22	96	111	51	22	147	106	0.788
	1 x 28	100	132	56	28	152	107	1.136
	1 1/4 x 35	114	133	57	35	172	121	1.434
	1 1/2 x 42	125	148	61	42	193	134	1.906
	2 x 54	146	149	75	54	227	158	2.512

TEMPERATURE RANGE

-10 to 120°C

OPTIONS

Available in standard flow (Fig.1732.PF), medium flow (Fig.1732M.PF) and low flow (Fig.1732L.PF)

SPECIFICATION

Bronze (BS EN 1982 CC491K) 'Y' Pattern Globe Type Fixed Orifice Double Regulating Valve incorporating integral orifice with corner tappings terminating in Hattersley Fig. 631 test points.

Double regulating feature set by Allen Key and valve operation by Microset handwheel. Disk with PTFE insert on sizes 1" and above. The entire unit provides a measurement accuracy of ± 5%. Conforms to BS7350 for flow measurement and regulation. Complete with Geberit Mapress bronze Press-Fit adaptors. Rated PN16 (Maximum temperature 12°C).

0813_v3 Every effort has been made to ensure that the information contained in this publication is accurate at the time of publishing. Hattersley Ltd assumes no responsibility or liability for typographical errors or omissions or for any misinterpretation of the information within the publication and reserves the right to change without notice.