

HC2000S Seat 3 Seater Length: 1800 mm (Surface Mounted)

This is a modern take on our more traditional range of seating. The HC2000 Range is elegant and simple.

HC2000S Seat Product Specifications:

- Timber and cast ductile iron seat with stainless steel frame and back support with side arm rests.
- Length 1800mm.
- Supports and arm rests are manufactured from 10mm cast ductile iron which is more durable than cast iron.
- The ductile iron components are galvanised with powder coat finish, as we manufacture all our products in house we can arrange any colour combination you require, see our colour palette section on page 109.
- The centre frame is 316 grade stainless steel in a polished finish (corrosion and salt water resistant)
- Timber slats are 140 x 40mm and 70 x 40mm FSC approved mahogany treated with a protective wood stain coating.
- Fixtures and fittings are stainless steel.
- Supports are surface mounted.

Fitting: Surface mounted, there are 2 fixing points on each support.

Concrete Foundations: Recommended concrete foundation 2000 x 800 x 150mm.

Options Available:

- Recycled composite timber is also available as an alternative to hardwood, for more information see page 58/59.
- Central Frame can be stainless steel or powder coated stainless steel.

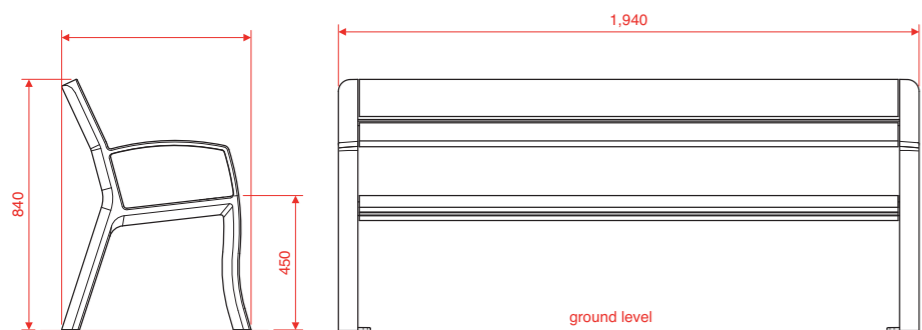
**HC2000B Bench** 3 Seater Length: 1800 mm (Surface Mounted)**HC2000B Bench Product Specifications:**

- Timber and cast ductile iron seat with stainless steel frame without back support.
- Length 1800mm.
- Supports and arm rests are manufactured from 10mm cast ductile iron which is more durable than cast iron.
- The ductile iron components are galvanised with powder coat finish, as we manufacture all our products in house we can arrange any colour combination you require, see our colour palette section on page 109.
- The centre frame is 316 grade stainless steel in a polished finish (corrosion and salt water resistant)
- Timber slats are 140 x 40mm and 70 x 40mm FSC approved mahogany treated with a protective wood stain coating.
- Fixtures and fittings are stainless steel.
- Supports are surface mounted.

Fitting: Surface mounted, there are 2 fixing points on each support.

Concrete Foundations: Recommended concrete foundation 2000 x 800 x 150mm.

Options Available:

- Recycled composite timber is also available as an alternative to hardwood, for more information see page 58/59.
- Central Frame can be stainless steel or powder coated stainless steel.
- Centre and side arm rests can be added to bench - ref: HC2000B with arms.

