

# HARMER

DRAINAGE SYSTEMS

Uniclass
L7313:P321
CI/SfB
(52.5)   lh1

February 2013

## Harmer SML

Socketless Soil and Waste Systems





[www.harmerdrainage.co.uk](http://www.harmerdrainage.co.uk)

The Harmer drainage website provides a wealth of information on all aspects of Harmer Drainage and compatible products. Also included are FAQs, file downloads for NBS specification clauses, COSHH information, a CAD library, and much more.

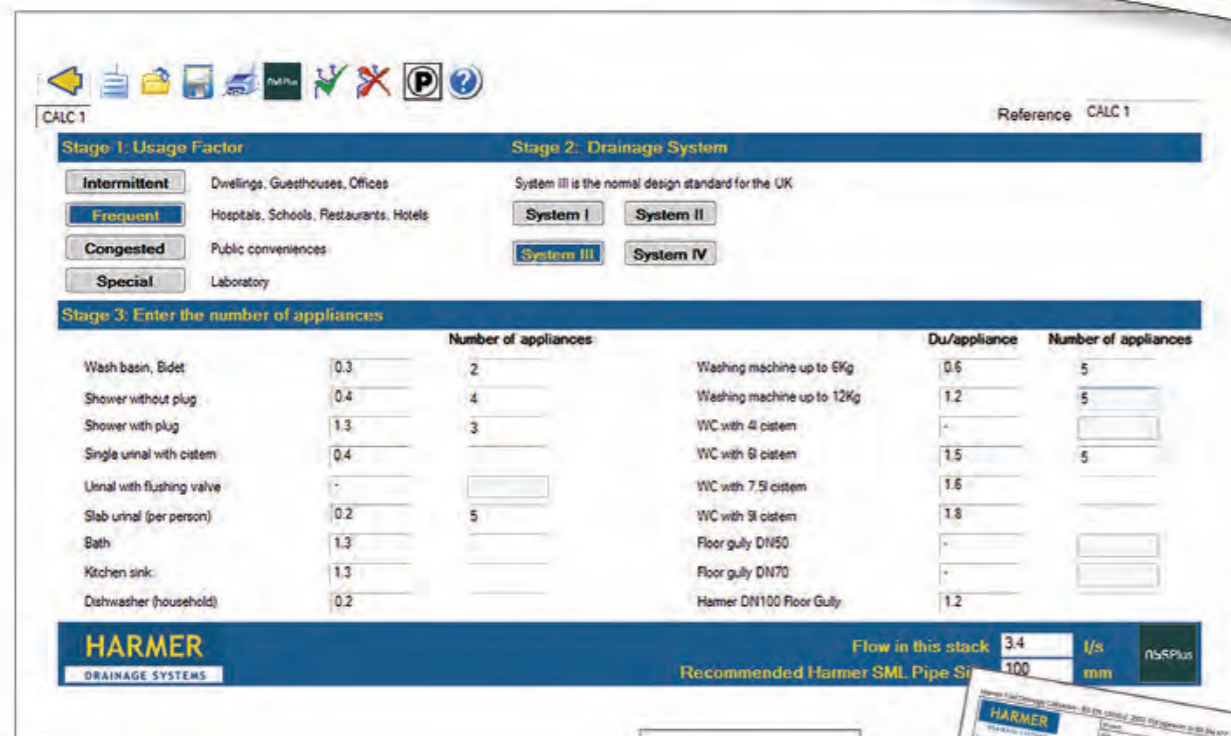

## Drainage Design Calculator

Architects and Building Services Engineers can now design and quantify all their Rainwater Drainage requirements using AlumasC's dedicated design software.

### Key Features

- Category 2 and 3 Flat Roof Drainage Calculator linked in to local rainfall data
- Rainwater Drainage Drawing tool integrating Quantities Schedule
- Eaves Drainage Gutter sizing and pipe calculator for Cast and Contemporary gutter types
- Hyperlinks to Product Literature, DWG files and application specific NBS Specification Clauses

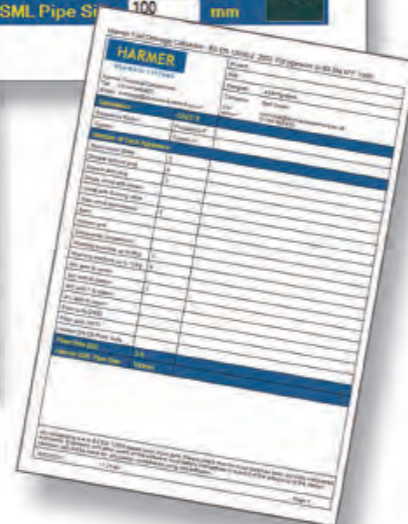

## Technical Support

Harmer drainage products are backed-up by comprehensive technical literature and by hands-on project support starting with technical and design advice, and extending through site installation to recommendation of appropriate maintenance regimes. Implementation is led by the AlumasC Drainage Manager appointed to the project.

## Introduction

The Harmer SML System	4
Quality and Sustainability	5
Benefits of the Harmer SML System	6
Benefits of Modern Cast Iron	7
The AlumasC Partnership	8
An Integrated Drainage Solution	9
Project Gallery	10
Harmer SML Product Range Summary	12
The Harmer SML Product Range	14

## SML Product Tables

Pipes	15
Pipe Couplings	15
Pipe Brackets	17
Pipe Fittings	19
Pipe Adaptors	30
Fixing Tools	31

## SML Technical Data

Pipes and Pipe Fittings	32
Couplings	34
Brackets	36

## SML Installation

Ductile Iron Coupling	38
Stainless Steel Coupling	39
Vertical Pipe Support	40
Horizontal Pipe Support	42
Acoustic Protection	43
Connection to Other Materials	44
Manifold Connection	46
Other Connections	47
Fixing Tools	48
Guideline to NBS Specification	49

## Harmer Roof Outlets, Floor Drains and Shower Drains

Harmer Drainage Outlets and Adaptors	50
Harmer Roof Outlets	51
Harmer Floor Drains	58
Harmer Pipe Adaptors	61
Harmer Shower Drains	62

## Other Products

Underground Drainage System	69
Other Harmer Drainage Products	70
AlumasC Premium Products	71





The Harmer SML lightweight cast iron pipework system is dry-jointed, Agrément certified, and has a proven track record for above-ground drainage. With its comprehensive range of fittings and accessories, SML is the ideal soil and waste system which can also be used for rainwater installations.

### All-Round Flexibility

The Harmer SML system consists of coated, socketless cast iron pipes and fittings simply joined with either ductile iron or stainless steel rubber-lined couplings. The range also includes bracketry for restraining the pipework vertically and supporting it horizontally, along with a choice of special connectors for linking with other materials.

Harmer SML provides value for money throughout the building life cycle, incorporating high performance materials, ease of installation and ease of access for maintenance.

Consequently, the SML system continues to be successfully used in market sectors ranging from hospitals, healthcare premises, commercial premises, offices, schools, industrial projects to civil engineering works and housing.



### All-Round Standards

Harmer SML fully conforms to BS EN 877, the European standard for cast iron pipes and fitting along with conformity with the CE mark.

In addition, Harmer SML has been awarded a British Board of Agrément certificate for couplings, pipes and fittings.

A correctly installed Harmer SML system will meet the performance standards set by BS EN 12056, the code of practice for gravity drainage systems that covers sanitary pipework and roof drainage inside buildings.

Consequently, the SML drainage pipe system is eminently suitable for all drainage applications required within buildings in the UK. SML is also officially approved for use in numerous other countries including Australia, the Czech Republic, Denmark, Finland, Germany, Hungary, Norway, Russia, Singapore, Sweden, Switzerland and the Ukraine.

### Key Features of Harmer SML

- A proven, Agrément certified system which meets the European standard BS EN 877.
- Excellent acoustic performance – tested in accordance with BS EN 14366: 2004.
- Non-combustible.
- High tensile strength.
- Choice of ductile or stainless steel couplings.
- Secure socketless fixing between pipe and fitting.
- Low maintenance.
- 100% recyclable.
- Quick to assemble.

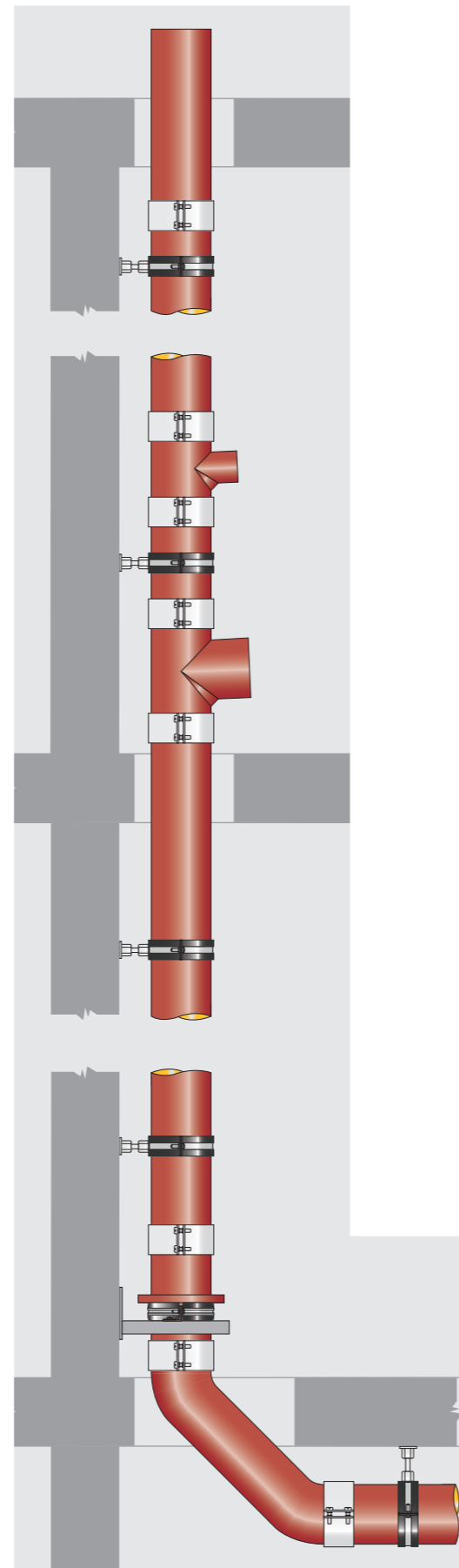

The full spectrum of assessment procedures and quality control standards have been employed by Alumasc to monitor the manufacture and performance of its cast iron products and systems, ensuring a responsible engagement with customers and the environment.

### Harmer SML Product Testing and Certification

British Board of Agrément Certificate No. 05/4191: For couplings, pipes and fittings. SML also complies with numerous other certified standards.



BS EN 877: European Standard for cast iron pipes and fittings. This standard sets requirements for materials, dimensions and tolerances, mechanical properties and standard coatings for pipes, fittings and associated accessories.

CE Mark: European product conformity to harmonised standard BS EN 877 in accordance with Construction Products Regulation 2013.



ISO 6594: International Standard for socketless drainage systems in cast iron.

BS EN 681/ISO 4633: Specification for Elastomeric Seals for Joints in Pipework and Pipelines.

BS EN 14366: 2004, Laboratory measurement of noise from waste water installations. Harmer SML test certificate P-BA 164/2008e and P-BA 165/2008e.

EN 13501-1: Fire classification of construction products and building elements. Harmer SML has an A1 fire classification. Test report KB-Hoch-080195.

BS EN 1561: Founding. Grey Cast Irons.

### Quality Assurance

BS EN ISO 9001: 2000, Registered No. 12 100 21864 This is a quality assurance scheme monitored by BSI's inspectorate that makes regular checks to ensure standards are maintained.



IZEG and GEG: IZEG is a resource centre for disseminating detailed information on the quality and performance of cast iron drainage products. The GEG quality seal is awarded to products that meet stringent quality regulations after rigorous testing undertaken by independent institutes.



### Codes of Practice

BS EN 12056-2: Code of Practice for gravity drainage systems inside buildings – sanitary pipework.

BS EN 12056-3: Code of Practice for gravity drainage systems inside buildings – drainage of roofs.

BS EN 752: 1996, Code of Practice for drain and sewer systems outside buildings.



### Standards Specific to the Düker Company

DIN 19522: German Standard for drainage systems in cast iron.

RAL-GZ 698: Quality Systems Certificate for cast iron drainage pipe systems.

MPA Dortmund 11 000 1436/01/01: Conformity to EN 877.

CSI 1094RF: Fire Resistance Test Report.

### Alumasc Environmental Policy

In addition to complying with environmental legislation, Alumasc is committed to developing its own measures to limit the adverse effects of its activities on the environment. To this end, Alumasc operates an environmental policy across all sites that fully integrates all aspects of company activities.

The Alumasc environmental policy sets the standards for site emissions, noise levels, vibrations, and also systematically assesses the introduction of new processes and procedures.

### Environmental Protection

BS EN ISO 14001: 2004, Manufacturing to Environmental Standards.

Grey cast iron is 100% recyclable. Pipe cuttings can also be included in recycling because the internal coating is free from benzopyrene and other environmentally dangerous materials.

### Trade Bodies

Harmer Drainage is a patron member of the Chartered Institution of Building Services Engineers (CIBSE)



## Benefits of the Harmer SML System

Harmer SML, a proven, Agrément certified system which meets the European Standard BS EN 877, offers a wide range of benefits.

### Fire Safe

- Non-combustible, therefore does not require costly fire protection collars.
- When tested by the MPA North-Rhine Westphalia Laboratory in Germany, SML cast iron proved superior compared to other drainage materials.
- Harmer SML has the highest fire classification A1 – tested in accordance with the requirements of EN 13501-1.

### Robust

- Lightweight, strong and durable.
- High tensile strength.
- Totally secure socketless fixing between pipe and fittings.

### Fit for Purpose

- High resistance to positive and negative pressure – axial restraint up to 10 bar possible, therefore no need to change material in sensitive areas.
- No expansion joints, deflection bends or other special expansion control techniques are required for the dimensionally stable pipes due to the low coefficient of thermal expansion of cast iron.

### Quiet

- Excellent acoustic performance, Harmer SML has been tested in accordance with BS EN 14366: 2004 – the latest test for acoustic performance of building materials.
- Typically, no special sound insulation measures required.

### Easy and Quick to Install

- Assembled by means of twin screw couplings.
- Easily connects to other materials via push-fit couplings.
- No special installation equipment required.
- No specialist experience required.

### Low Maintenance

- Epoxy coatings ensure pipes and fittings need minimal maintenance over lifetime of drainage installation.
- Inherent resistance to external accidental damage and vandalism.

### Value for Money

- Less fixing necessary, as fewer brackets are required because of greater pipe spanning capability.
- Cast iron has a proven track record for its longevity over the lifetime of a building.

### Sustainable

- Long life cycle.
- 100% recyclable material therefore all waste can be returned to the furnace to make new cast iron products.



Stainless Steel Coupling



Ductile Iron Coupling

## Benefits of Modern Cast Iron

For centuries, cast iron has been a preferred material for building construction, because of its longevity in a wide range of applications. Advances in cast iron technology have ensured that today's products are fully attuned to modern construction needs.

### 21st Century Technology

Cast iron's high carbon content (2%-4%) makes it very suitable for casting pipes and other cylindrical components by pouring molten iron into permanent moulds which are spun at high speed. The liquid is forced to the sides of the mould lining producing a casting that has a uniform wall thickness. As a result of this centrifugal force, the iron becomes denser and stronger than gravity cast iron, making it particularly well suited to drainage applications, where pipes can be made in longer lengths.

### Temperature Extremes and Linear Expansion

Cast iron's low coefficient of thermal expansion (0.0105 mm/m/K) means that components made from it can be subjected to extreme temperatures without distortion, thereby requiring no costly expansion joint provision to take up differential movement. This is particularly beneficial where cast iron components are used in conjunction with concrete structures (concrete has an almost identically low coefficient of thermal expansion).

### Acoustic Performance

The crystalline nature of cast iron gives the material a very high damping capacity thereby significantly reducing noise transmission through cast components installed within building structures.

Harmer SML has been tested for its acoustic performance in accordance with BS EN 14366: 2004.

### High Strength

The crystalline structure of cast iron also gives the material high strength and robustness. Once installed, cast iron components resist impact damage even in exposed areas, such as shopping centres, car parks and schools. Pipes can span longer distances and so less fixing back to supporting structures can be employed.

### Durability

Inherent corrosion resistance coupled with tough epoxy coatings ensures that cast iron components will need minimal maintenance during the lifetime of a drainage installation. The durable nature of cast iron components is thus ideal when used in inaccessible or difficult to reach areas.

### Environmental Considerations

Made from 100% recycled scrap metals, cast iron can be recycled indefinitely, and therefore should not be disposed of in landfill.

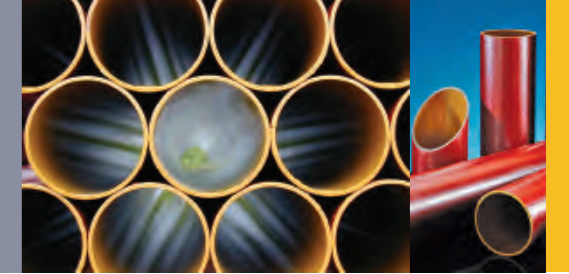

### Fire Performance

Cast iron is non-combustible and therefore does not propagate fire nor emit toxic gases, unlike plastics-based systems. Consequently, installed cast iron components do not require costly fire protection measures.



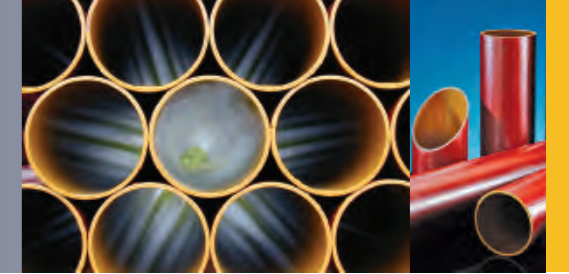

Alumasc is the UK specialist in lightweight cast iron soil and waste systems, which form part of the company's renowned Harmer range.

## The Partnership

Alumasc has a long-standing partnership with Düker GmbH who manufacture Harmer SML at their plant in Karlstadt, Germany. Since their formal (GmbH) establishment in 1913, Düker has strived to incorporate the beneficial characteristics of cast iron within its drainage products.

In 1967, Düker revolutionised the cast iron drainage market by developing the spigot-only (i.e. socketless) jointing technique for drainage pipes, setting a new benchmark for reliability, quality and speed of installation.

The Düker foundry utilises state-of-the-art equipment and machinery in its production processes, with continuous investment in product development and technology.

Alumasc and Düker are committed to providing a high quality soil and waste system that meets the requirements of BS EN 877, the European standard for cast iron pipes and fittings.



Karlstadt Plant, Germany



Centrifugal casting process



Harmer SML is fully compatible with Alumasc's ranges of Aluminium and Cast Iron Roof Outlets, Aluminium Floor Drains and Aluminium and ABS Shower Drains, enabling flexible design solutions to be found for all soil, waste and rainwater drainage configurations. Harmer SML is also supported by Alumasc's wide-ranging technical expertise and resources.

## The Compatible Ranges

**Harmer AV Aluminium Roof Outlets** are high performance outlets with circular flanges, suitable for all regular flat roofing applications with continuous membranes. They are available with spigot or screw connection, for vertical, horizontal or 45 degree discharge. *(See pages 50, 51 and 53)*

**Harmer Detail Aluminium Roof Outlets** are for applications such as balconies and car parks, with two-way outlets available for use where the roof surface abuts a wall or parapet. *(See pages 50, 51 to 53)*

**Harmer Cast Iron Roof Outlets** provide a practical solution to many building drainage applications. Available in medium sump and large sump bodies, two-way outlets and an extensive range of load bearing grates. *(See pages 50, 54 to 57)*

**Harmer Floor Drains** comprise drain bodies in powder coated aluminium, together with an extensive range of grates (including round and square configurations) available in stainless steel or nickel bronze. The range is suited to virtually any interior drainage application and all types of flooring. The drain bodies are available either trapped or untrapped, with vertical or horizontal spigot connection, and with or without side outlets for connection to sink, bath, shower wastes, etc. *(See pages 50, 58 to 61)*

**Harmer Shower Drains** are a high performance range of Aluminium and ABS antimicrobial shower drains for concrete or timber floors in both refurbishment and new build projects. Available with a choice of attractive caps and grates to suit individual project requirements. *(See pages 50, 62 to 68)*

## Technical Support and Resources

### Technical Support

Comprehensive data for specification and use of all products and systems is available in published form, and on the company website. This is backed up by pro-active support on a project basis, led by specialist area managers and using the latest CAD technology including Architectural Desktop and Autocad.

### Alumasc Resources

- An enthusiastic and committed workforce backed up by professional management and sales teams.
- State-of-the-art and quality accredited production facilities for aluminium and render products, with a factory finishing capability for the former.
- A carefully developed and nurtured supply chain for world class products to complement the in-house manufacture and to ensure a fully rounded and comprehensive offer for drainage and exterior systems.
- A strong research and development capability.
- Technical support for design and costing, based on the latest CAD technology and a comprehensive range of technical literature.

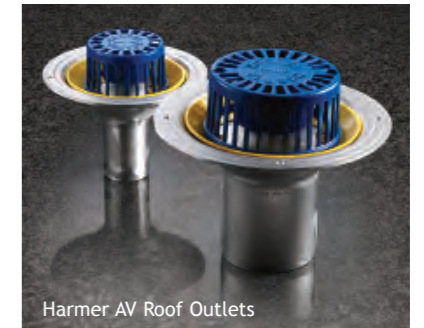

Harmer AV Roof Outlets

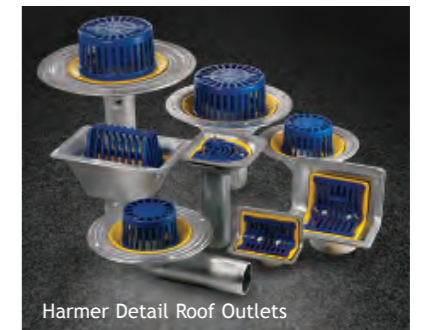

Harmer Detail Roof Outlets



Harmer Cast Iron Outlets



Harmer Floor Drains



Harmer Shower Drains

The Harmer SML lightweight cast iron pipework system, and its comprehensive range of fittings and accessories, is the ideal soil and waste system for specification across a spectrum of construction types, including retail, commercial, civil, transport, sport, and health projects where it can also be used for rainwater installations.



London Cancer Clinic

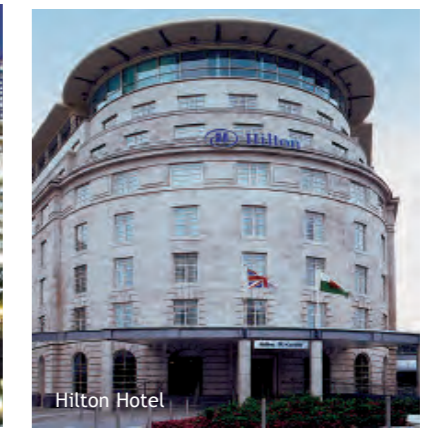

Photo courtesy of Formation Architects Ltd

No. 1 Old Broad Street



West India Quay



Hilton Hotel

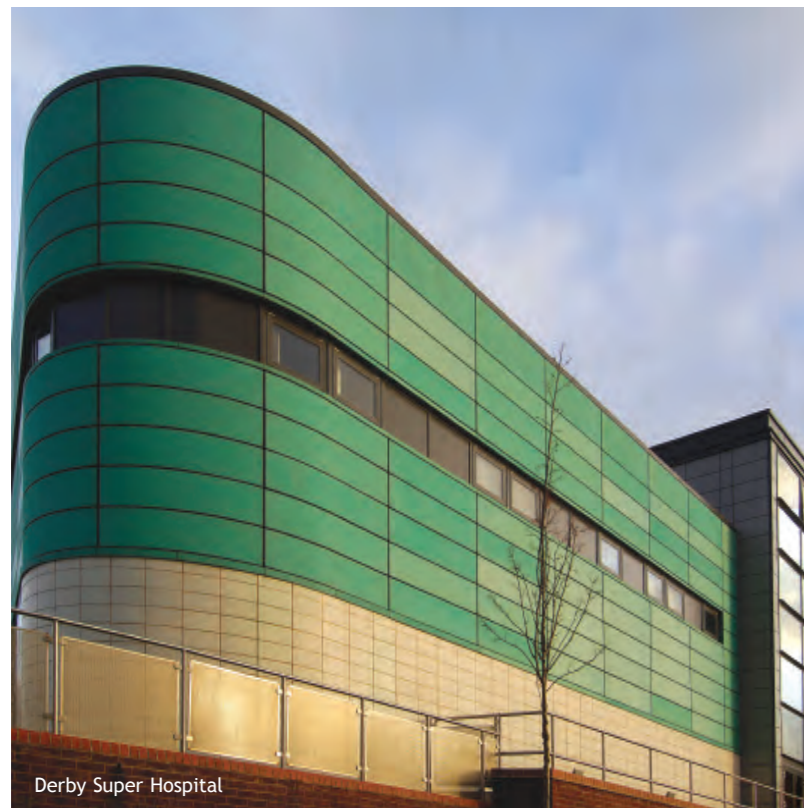

Derby Super Hospital



Royal London Hospital



Millennium Stadium



Norfolk and Norwich University Hospital



Walsgrave Hospital

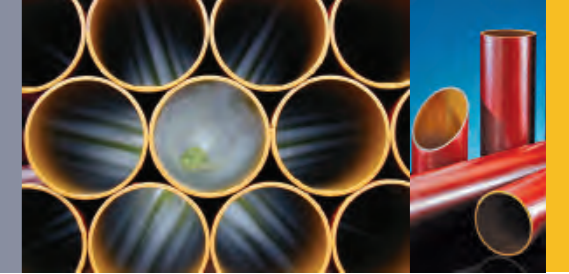

All Harmer SML pipes and fittings comply with BS EN 877, being manufactured in Germany under strict factory-controlled conditions to meet the highest performance standards. They are durable, recyclable, quick and easy to install and require low maintenance.



## Pipes

Harmer SML pipes are available in standard 3m lengths, in diameters of 50mm to 400mm, providing everything for high performance, lightweight cast iron soil and waste systems. (See page 15)

Pipes have an exterior primer coating, minimum thickness 40 µm. The interior of pipes has an epoxy coating with a minimum thickness of 120 µm.

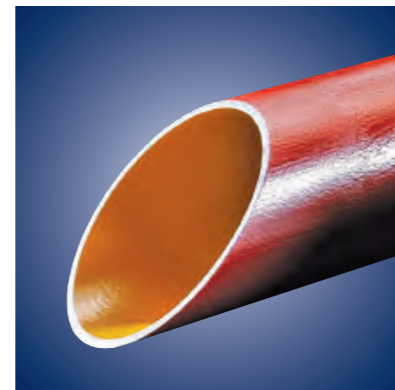

## Harmer MLK

The Harmer MLK underground drainage system has an identical material specification to Harmer SML but with additional coating specification to cope with aggressive ground conditions and waste water applications. Harmer MLK and Harmer SML are fully compatible. (See page 69)

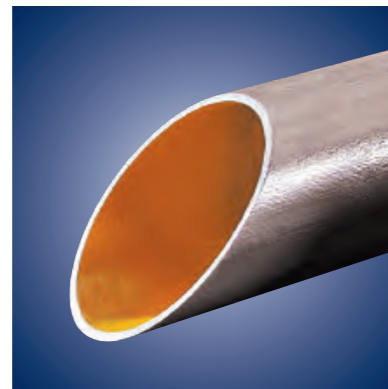

## Fittings

Harmer SML fittings shown opposite are coated externally and internally with an epoxy coating, minimum thickness 60 µm.



## Branches

Fittings designed to accommodate connection of branch pipework to a principal vertical pipe stack. The available range includes single and double branches, swept entry branches, corner branches and combination branches. (See pages 22–24, 26)

## Bracketry

Maintaining the stability of above-ground pipework is vital, and to this end Alumasc has developed a range of support bracketry that supports both vertically and horizontally. The range includes vertical, horizontal hanging and stack support brackets, which are available in ductile cast iron, zinc plated or pre-galvanised, and fitted with sound-deadening runner linings. (See pages 17–18)



## Bends and Offsets

A wide range of bends to accommodate change of direction, meeting a wide variety of design requirements, including - single bends, short and long tail double bends, long radius bends, bends with spigots, rest bends and offsets. (See pages 19–21)



## Access Fittings

Designed to allow access for inspection and rodding – includes circular access pipes, rectangular access pipes, access bends and branches. (See pages 25–26)



## Couplings and Adaptors

Harmer SML couplings are specially designed for joining lengths of Harmer SML pipe, and for joints between pipes and fittings. Couplings are available in stainless steel and ductile iron. Like Harmer SML pipes and fittings, all Harmer SML couplings have been subject to rigorous testing and meet the requirements of BS EN 877. (See pages 15–16, 30)

## Completing the Product Range

The range also includes boss pipes, reducers, end caps, downpipe supports, bearing rings, manifold, connectors, flanged pipes and traps. (See pages 26–29)

# The Harmer SML Product Range



# Pipes and Pipe Couplings



The complete range of Harmer SML pipes, pipe fittings, pipe couplings and pipe brackets will be found in the following list of product tables.



Pipes		Pipe Fittings (Bends and Offsets)		Pipe Fittings (Miscellaneous)	
All diameters in 3000mm lengths	15	Single Bends 15°	19	Boss Pipes 88°	26
<b>Pipe Couplings</b>		Single Bends 30°	19	Reducers	26
Ductile Iron	15	Single Bends 45°	19	End Caps – Blank Ends	27
Duo	15	Single Bends 68°	19	End Caps – Tapped	27
Grip	15	Single Bends 88°	20	End Caps – Plug	27
Adaptor	16	Short Double Bends 88°	20	Downpipe Supports	27
Connect-G Inox High Pressure	16	Long Double Bends 88°	20	Bearing Rings	27
'A' Ring Rubber	30	Long and Medium Radius Bends 88°	20	Manifold Connector	28
'O' Ring Rubber	30	Bends with Long Tails 45°	21	Sleeved Connectors	28
<b>Pipe Brackets</b>		Bends with Long Tails 88°	21	Stoneware Connectors	28
Ductile Iron	17	Bends with Long Tails 135°	21	Flanged Connectors	28
Optimal	17	Offsets	21	Pipe with Wall Flange	29
Optimal HD	17	Rest Bend	21	Branch Traps	29
Hanging	17	<b>Pipe Fittings (Branches)</b>		Plain Trap	29
Acoustic Dampener (dB Fix)	18	Single Branches 45°	22	Rainwater Stench Traps	29
Wall Plate and Threaded Rod	18	Single Branches 68°	22	<b>Pipe Adaptors</b>	
Stack Pipe Support	18	Single Branches 88°	23	Konfix Single (Waste adaptor)	30
Stand Pipe Support	18	Double Branches 45°	23	Konfix Multi (Waste adaptor)	30
		Double Branches 68°	23	Rubber Pipe Joints	30
		Double Branches 88°	23		
		Swept Double Branches 88°	24		
		Corner Branches 88°	24		
		Combination Branches	24		
		<b>Pipe Fittings (Access)</b>			
		Round Access Pipes	25		
		Rectangular Access Pipes	25		
		Long and Short Access Bends 88°	25		
		Swept Entry Branches 88°	26		



## Pipes

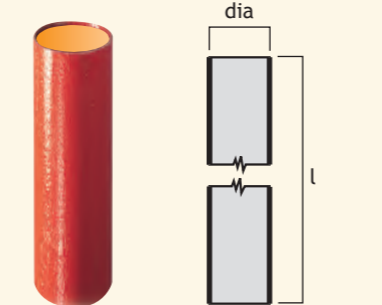

Pipe Dia (mm)	Pipe OD	l	Nom Weight (kg)	Product Code
50	58	3000	13.0	660004
70	78	3000	17.7	660094
100	110	3000	25.2	660184
125	135	3000	35.4	660274
150	160	3000	42.2	660364
200	210	3000	69.3	660454
250	274	3000	99.8	660544
300	326	3000	129.7	660634
400	429	3000	180.0	660724

400mm dia pipe is available on request

## Ductile Iron Couplings

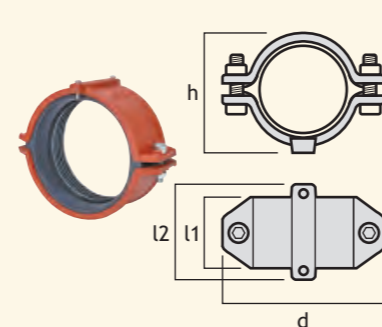

Pipe Dia (mm)	h	d	l1	l2	Nom Weight (kg)	Product Code
50	79	111	50	68	0.6	235849
70	89	132	50	68	0.7	235526
100	134	168	60	78	1.1	235357
150	184	230	71	89	1.9	235358
200	231	278	82	100	3.5	235527

Supplied with integral electrical continuity screws.

## Duo Couplings

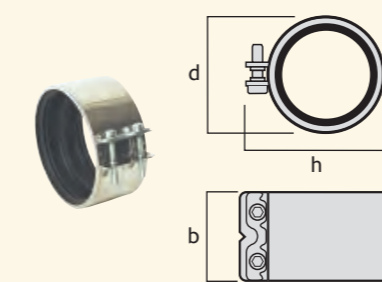

Pipe Dia (mm)	Bolts	d	h	b	Product Code
50	2	75	90	55	3140/50
70	2	95	110	55	3140/70
100	2	125	140	55	3140/100
125	2	125	165	70	3140/125
150	2	175	190	70	3140/150
200	4	220	255	70	3140/200
250	8	280	315	140	3140/250
300	8	335	370	140	3140/300

Supplied as standard with electrical continuity spur.  
400mm coupling available on request (Ref: Düker CE Dual Ring Coupling)

## Grip Couplings

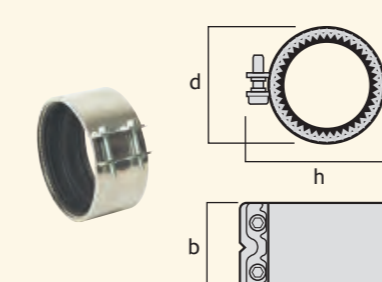

Pipe Dia (mm)	Bolts	d	h	b	Product Code
50	2	75	90	55	3176/50
70	2	95	110	55	3176/70
100	2	125	140	55	3176/100
125	2	125	165	70	3176/125
150	2	175	190	70	3176/150
200	4	220	255	70	3176/200

All pipe coupling dimensions in above tables are average (coupling unfastened).

# Pipe Couplings



# Pipe Brackets



## Adaptor Couplings

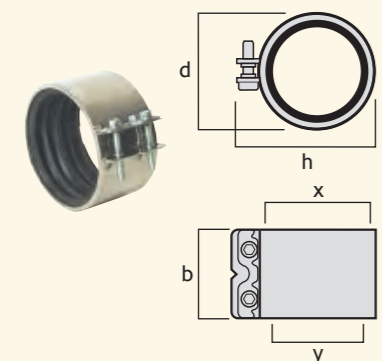

Pipe Dia (mm)	Bolts	d	h	b	x	y	Product Code
70	2	95	110	70	83-84	75-76	3151/070075
100	2	130	145	70	116-119	108-113	3102/100
150	4	180	215	70	168	159	3102/150

Adapts lightweight 'soil' to conventional 'drain'.

## Combi Grip Collar EK



Pipe Dia (mm)	a(d)	b(l)	Product Code
50	124	72	235360
70	149	72	235498
100	180	85	235280
125	210	98	235315
150	230	98	235316
200	287	111	235281
250	267	130	216888
300	419	130	100304

## Connect-G Inox High Pressure Couplings

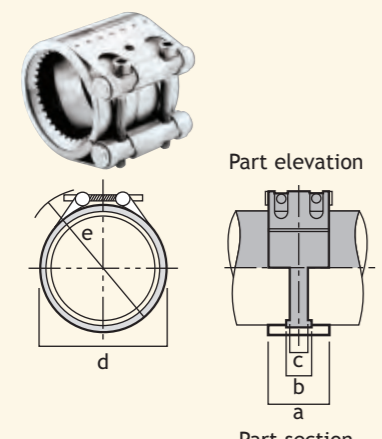

Pipe Dia (mm)	a	b	c	d	e	Product Code
50	78	29	17	85	105	234843
70	98	40	25	100	120	234844
100	98	40	25	130	150	234845
125	115	50	35	165	195	234846
150	115	50	35	185	215	234847
200	140	67	35	240	270	234848
250	140	67	35	305	335	234849
300	140	67	35	360	390	234850
400	142	67	35	460	490	234851

Coupling with axial restraint for installations above or below ground.

**NEW** High Pressure Couplings now available please contact Harmer Technical on Tel: 01744 648400 for more information.

All pipe coupling dimensions in above tables are average (coupling unfastened).

## Ductile Bracket (For Vertical and Horizontal Pipework Applications)

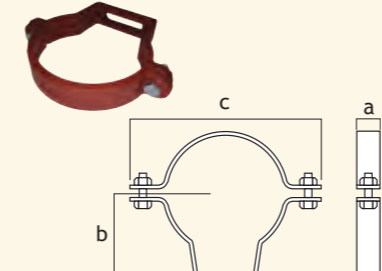

Pipe Dia (mm)	a	b	c	Nom Wt (kg)	Product Code
50	28	62	114	0.4	DB050
70	28	72	135	0.5	DB070
125	28	88	167	0.6	DB100
150	30.5	114	216	0.85	DB150
200	30.5	148	267	1.6	DB200

## Optimal Bracket (For Vertical and Horizontal Pipework Applications)

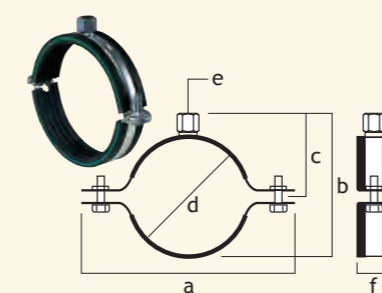

Pipe Dia (mm)	a	b	c	d	e	f	Nom Wt (kg)	Product Code
50	102	90	50	57-64	M8/M10	23	0.1	220012
70	127	110	60	73-80	M8/M10	23	0.2	220013
100	163	140	77	108-114	M8/M10	25	0.3	220014
125	190	170	90	133-141	M8/M10	25	0.35	220015
150	228	186	100	159-168	M10	25	0.4	220016
200	273	245	120	200-210	M10	25	0.5	220011

When used in vertical applications, additional stack support is required (See pages 40 and 41)  
Acoustically tested to EN 14366: 2004 (See page 43)

## Optimal HD Bracket (For Vertical and Horizontal Pipework Applications)

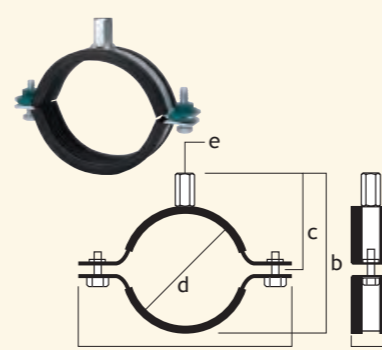

Pipe Dia (mm)	a	b	c	d	e	f	Nom Wt (kg)	Product Code
100	182	160	93	108-116	M10/M12	30	0.5	33143116
125	207	184	104	132-140	M10/M12	30	0.5	33143140
150	254	223	124	159-164	M10/M12	38	1.1	33143169
200	299	267	146	203-213	M10/M12	38	1.5	33143213
250	367	327	175	265-275	M16	48	2.5	33163275
300	453	412	217	315-325	M16	48	3.0	33163323

When used in vertical applications, additional stack support is required (See pages 40 and 41)  
Acoustically tested to EN 14366: 2004 (See page 43)

## Hanging Bracket – Pre Galvanised (For Horizontal Pipework Applications)

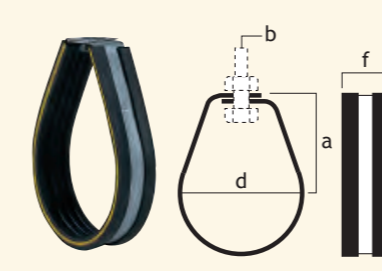

Pipe Dia (mm)	a	b*	d	f	Nom Weight (kg)	Product Code
50	60	M10	58	23	0.1	220045
70	95	M10	78	23	0.2	220046
100	110	M12	110	23	0.3	220047
125	140	M12	135	25	0.35	220048
150	150	M12	160	25	0.4	220049
200	190	M16	220	25	0.5	220050
250	242	M16	276	50	1.5	220051
300	265	M16	328	50	2.0	220052

\*Bolt not supplied

All pipe bracket dimensions and weights in above tables are average.

# Pipe Brackets



# Pipe Fittings



## Acoustic Dampener (dB-Fix)

Type	a	b	c	Rod Size	Safe Load* (N)	Product Code
dB-Fix	60	34	40	M10	500	6697005

A noise insulating fixing point for use in acoustically protected installations, tested in accordance with EN 14366: 2004 (See page 43)

\* Refers to pull down load (in horizontal pipework applications)

## Wall Plate and Threaded Rod

Type	a	b	c	Rod Size	Safe Load* (N)	Product Code
Wall Plate	45	25	80	M10	2000	220006
Threaded Rod	—	—	—	M8x1m	—	220000
	—	—	—	M10x1m	—	220001
	—	—	—	M12x1m	—	220002

For use with Optimal and Optimal HD Brackets up to 200mm, for a fixed standoff position (giving a distance of 60mm ± 2mm from wall to back of pipe)

\* Refers to pull down load (in horizontal pipework applications)

## Stack Pipe Support Bracket (For Vertical Pipework Applications)

Pipe Dia (mm)	a	b	c	d	e	f	Nom Wt (kg)	Product Code
70	212	114	210	78	13x23	25	2.0	4323/70
100	244	114	210	110	13x23	25	2.2	4323/100
125	269	114	210	135	13x23	25	2.4	4323/125
150	293	114	210	160	13x23	25	2.6	4323/150
200	343	114	250	210	13x23	25	3.0	4323/200

To be used in combination with Downpipe Support. (See page 27, 37 and 40)

(Shown with Downpipe Support fitting)

## Stand Pipe Support Bracket (For Vertical Pipework Applications)

Pipe Dia (mm)	a	b	c	d	e	f	Nom Wt (kg)	Product Code
70	154	130-140	83-93	78	45-55	75	1.0	3363070
100	176	165-175	100-110	110	45-55	75	1.1	3363100
125	192	190-200	113-123	135	45-55	75	1.2	3363125
150	233	225-235	127-137	160	45-55	75	1.4	3363150

(See page 37 and 41 for specification and installation details)

All pipe bracket dimensions and weights in above tables are average.

## Single Bends 15°

Pipe Dia (mm)	x	Nom Weight (kg)	Product Code
50	40	0.4	661004
70	45	0.6	661064
100	50	1.0	661124
125	60	1.7	661184
150	65	2.5	661244
200	80	4.6	661304

## Single Bends 30°

Pipe Dia (mm)	x	Nom Weight (kg)	Product Code
50	45	0.5	661014
70	50	0.7	661074
100	60	1.3	661134
125	70	2.0	661194
150	80	3.0	661254
200	95	5.4	661314
250	110	9.7	661364
300	130	15.5	661384

## Single Bends 45°

Pipe Dia (mm)	x	Nom Weight (kg)	Product Code
50	50	0.5	661024
70	60	0.9	661084
100	70	1.6	661144
125	80	2.3	661204
150	90	3.5	661264
200	110	6.2	661324
250	130	10.3	661374
300	155	17.5	661394
400	257	36.0	661284

400mm dia single bend is available on request

## Single Bends 68°

Pipe Dia (mm)	x	Nom Weight (kg)	Product Code
50	65	0.7	661034
70	75	1.1	661094
100	90	1.9	661154
125	105	2.9	661214
150	120	4.3	661274
200	145	7.7	661334



## Single Bends 88°

Pipe Dia (mm)	x	Nom Weight (kg)	Product Code
50	75	0.7	661054
70	90	1.2	661114
100	110	2.1	661174
125	125	3.2	661234
150	145	4.9	661294
200	175	8.1	662784
250	225	13.8	233621
300	260	28.0	233622

## Short Double Bends 88°

Pipe Dia (mm)	x	l	a	Nom Weight (kg)	Product Code
50	50	121	100	1.2	661484
70	60	145	120	1.8	661494
100	70	170	140	3.2	661504
125	80	195	160	4.6	661514
150	90	219	180	7.0	661524

## Long Double Bends 88°

Pipe Dia (mm)	x	l	a	Nom Weight (kg)	Product Code
70	60	273	300	3.2	662734
100	70	291	312	4.8	662744
125	80	308	321	6.8	662754
150	90	325	333	9.6	662764

## Long and Medium Radius Bends 88°

Pipe Dia (mm)	x1	a	x2	b	Nom Weight (kg)	Product Code
100*	255	55	255	55	5.5	235125L
150**	250	80	250	80	8.5	235126L

\* Long radius bend \*\*Medium radius bend

## Bends with Long Tails 45°

Pipe Dia (mm)	Angle°	x1	x2	k	Nom Weight (kg)	Product Code
70	45	250	60	190	2.6	662054
100	45	250	70	180	4.2	662074

k = dimension for maximum cut back

## Bends with Long Tails 88°

Pipe Dia (mm)	Angle°	x1	x2	k	Nom Weight (kg)	Product Code
70	88	250	90	160	2.8	662064
100	88	250	110	140	4.6	662084

k = dimension for maximum cut back

## Bend with Long Tails 135°

Pipe Dia (mm)	Angle°	x1	x2	k	Nom Weight (kg)	Product Code
100	135	312	150	100	5.0	662774

k = dimension for maximum cut back

## Offsets

Pipe Dia (mm)	Offset	x	l	Nom Weight (kg)	Product Code
100	65	70	205	2.5	662864
100	130	70	270	3.4	662874
100	200	70	340	4.4	662884

## Rest Bend

Pipe Dia (mm)	x1	a	x2	b	Nom Weight (kg)	Product Code
100	260	55	251	56	5.7	100263



## Single Branches 45°

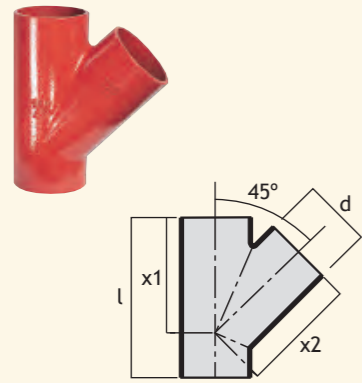

Pipe Dia (mm)	d	x1	x2	l	Nom Weight (kg)	Product Code
50	50	115	115	160	1.2	664004
70	50	130	130	170	1.6	663034
70	70	145	145	200	2.1	663064
100	50	150	150	180	2.3	663094
100	70	170	170	215	3.0	663124
100	100	190	190	260	3.8	663154
125	50	170	170	190	3.2	663184
125	70	185	185	225	4.0	663214
125	100	210	210	270	5.0	663244
125	125	230	230	305	6.1	663274
150	70	205	205	235	5.3	663334
150	100	225	225	280	6.5	663364
150	125	245	245	315	7.7	663394
150	150	265	265	355	9.2	663424
200	70	235	240	250	8.0	663484
200	100	260	260	300	9.8	663514
200	125	280	280	335	11.9	663544
200	150	300	300	375	13.3	663574
200	200	340	340	455	17.2	663604
250	100	305	305	320	15.4	663634
250	125	330	330	365	17.7	664504
250	150	350	350	405	20.2	664514
250	200	380	380	470	24.8	663644
250	250	430	430	560	31.5	663654
300	100	345	345	350	22.0	663664
300	125	360	360	375	23.9	664524
300	150	380	380	415	26.9	664534
300	200	415	440	485	34.0	664444
300	250	465	465	580	42.1	663674
300	300	505	505	660	50.1	663684
400*	300	555	565	660	60.0	663694

d = connecting branch dia  
\* 400mm dia single branch is available on request

## Single Branches 68°

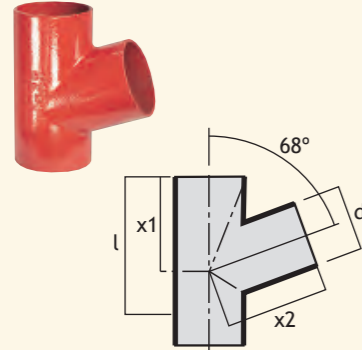

Pipe Dia (mm)	d	x1	x2	l	Nom Weight (kg)	Product Code
50	50	80	80	135	1.0	663014
70	50	90	90	140	1.3	663044
70	70	100	100	170	1.7	663074
100	50	110	100	155	1.9	663104
100	70	110	120	180	2.4	663134
100	100	130	120	180	2.9	663164
125	50	110	120	165	2.7	663194
125	70	120	130	190	3.2	663224
125	100	140	145	225	4.0	663254
150	100	150	155	235	5.2	663374
150	125	165	170	265	6.1	663404
150	150	180	180	295	7.1	663434

d = connecting branch dia

## Single Branches 88°

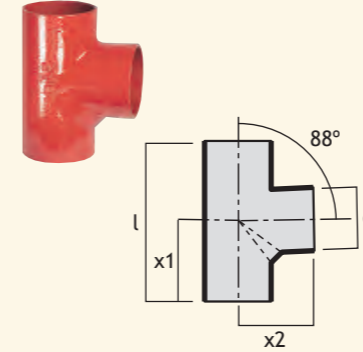

Pipe Dia (mm)	d	x1	x2	l	Nom Weight (kg)	Product Code
50	50	66	80	145	0.9	663024
70	50	72	90	155	1.4	663054
70	70	83	95	180	1.7	663084
100	50	76	105	170	2.1	663114
100	70	88	110	190	2.4	663144
100	100	105	115	220	2.9	663174*
125	50	82	120	180	3.0	663204
125	70	93	125	200	3.4	663234
125	100	110	130	235	4.0	663264
125	125	123	135	260	4.6	663294
150	50	100	140	200	4.4	663324
150	100	115	145	245	5.5	663384
150	125	128	150	275	8.2	663414
150	150	142	155	300	6.9	663444

d = connecting branch dia  
\* Product code 663174 is available with a 250mm long spigot. When this is required specify code 664454

## Double Branches 45°

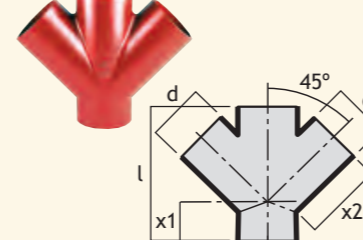

Pipe Dia (mm)	d	x1	x2	l	Nom Weight (kg)	Product Code
100	100	70	190	260	4.0	100260
150	100	55	225	280	5.4	661444

d = connecting branch dia

## Double Branches 68°

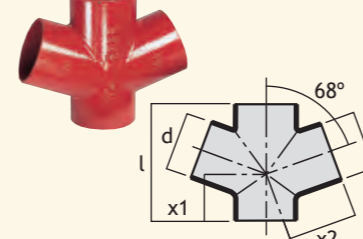

Pipe Dia (mm)	d	x1	x2	l	Nom Weight (kg)	Product Code
100	100	85	130	215	3.6	663864
125	100	85	145	225	4.6	663954

d = connecting branch dia

## Double Branches 88°

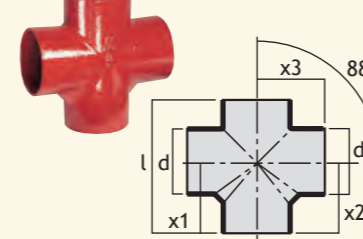

Pipe Dia (mm)	d	d2	x1	x2	x3	l	Nom Wt (kg)	Product Code
100	50	50	94	94	105	170	2.2	663814
100	70	70	102	102	110	190	2.2	663844
100	100	100	115	115	115	220	3.2	663874
150	100	70	130	112	145	245	6.0	664184
150	100	100	130	112	145	245	6.1	664084

d = connecting branch dia

# Pipe Fittings



# Pipe Fittings



## Swept Double Branches 88°

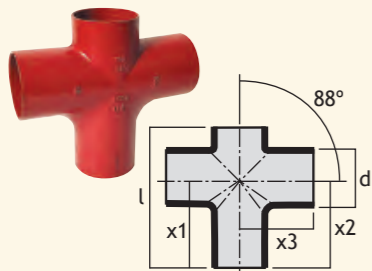

Pipe Dia (mm)	d	x1	x2	x3	l	Nom Wt (kg)	Product Code
100	100	170	170	150	270	4.5	100264

## Round Access Pipes

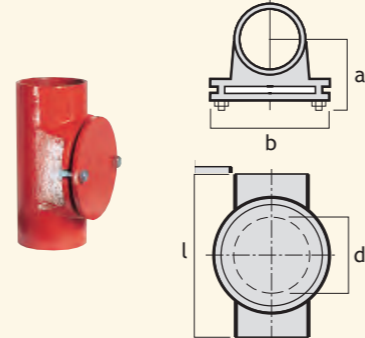

Pipe Dia (mm)	a	b	d	l	Access	Nom Wt (kg)	Product Code
50	59	105	53	175	✓	2.1	669580
70	69	125	73	205	✓	2.9	669583
100	84	159	104	250	✓	5.5	669586

## Corner Branches 88°

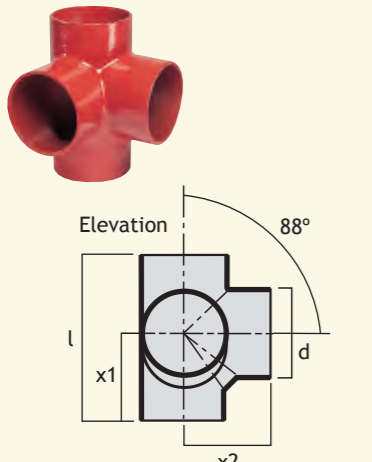

Pipe Dia (mm)	d	x1	x2	l	Nom Weight (kg)	Product Code
100	70	102	110	190	2.7	662044
100	100	115	115	220	3.1	662034*
125	70	107	125	200	3.7	662024
125	100	125	130	235	4.4	662014
150	100	130	145	245	6.1	664434

d = connecting branch dia

\* Product code 662034 is available with a 250mm long spigot. When this is required specify code 664464.

## Rectangular Access Pipes

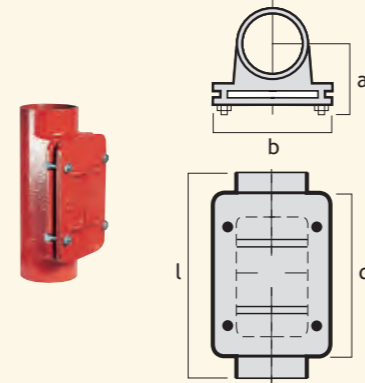

Pipe Dia (mm)	a	b	d	l	Access	Nom Wt (kg)	Product Code
100	83	160	230	320	✓	7.3	669624
125	101	190	255	355	✓	10.0	669627
150	112	215	280	395	✓	14.5	669630
200	137	262	330	465	✓	22.0	669633
250	170	330	380	540	✓	36.5	669612
300	195	380	430	610	✓	51.0	669615

## Combination Branches

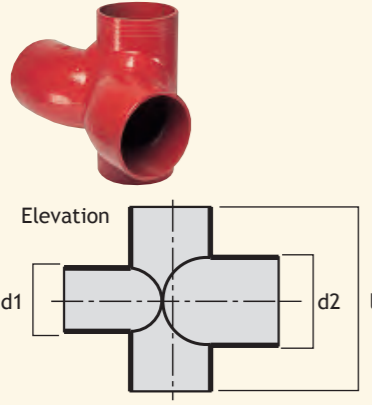

Pipe Dia (mm)	d1	d2	l	Nom Weight (kg)	Product Code
100	70	100	230	4.5	665834
100	100	100	230	5.0	665924

d = connecting branch dia

## Long and Short Access Bends 88°

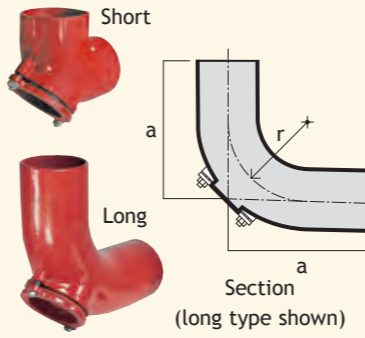

Pipe Dia (mm)	Type	a	r	Access	Nom Weight (kg)	Product Code
100	Short	110	—	✓	3.1	661174A
150	Short	145	—	✓	6.1	232741
100	Long	230	150	✓	6.0	661174AL



## Swept Entry Branches 88° – With and Without Access

Pipe Dia (mm)	a	b	c	d	l	Access	Nom Wt (kg)	Product Code
100	168	102	150	100	270	✗	3.7	663174S
100	168	102	150	100	270	✓	4.7	663174SA
150	183	117	202	100	300	✗	7.0	235684

## Boss Pipes 88°

Pipe Dia (mm)	Boss Type	a	b	c	d	l	Nom Wt (kg)	Product Code
100	B	75	75	75	2" BSP	150	2.0	663114B
100	DB	75	75	75	2" BSP	150	2.3	663114DB
100	CB	75	75	75	2" BSP	150	2.3	663114CB
150	B	88	88	104	2" BSP	175	3.8	232746
150	DB	88	88	104	2" BSP	175	3.8	237738

d = connecting branch dia

## Reducers

Pipe Dia (mm)	a	l	Nom Weight (kg)	Product Code
70	50	75	0.5	662504
100	50	80	0.9	662514
125	50	85	1.4	662534
150	50	95	2.0	662564
100	70	85	0.9	662524
125	70	90	1.5	662544
150	70	100	2.1	662574
125	100	95	1.5	662554
150	100	105	2.2	662584
200	100	115	4.1	662604
150	125	110	2.2	662594
200	125	120	4.1	662614
200	150	125	4.3	662624
250	150	135	6.8	662634
300	150	150	10.7	662494
250	200	145	7.0	662644
300	200	160	11.4	662714
300	250	170	12.4	662724
400*	300	180	15.0	662444

\*400mm dia pipe is available on request

## End Caps – Blank Ends

Pipe Dia (mm)	l	Nom Weight (kg)	Product Code
50	30	0.2	665504
70	35	0.4	665514
100	40	0.5	665524
125	45	1.1	665534
150	50	1.7	665544
200	60	3.1	665554
250	70	6.0	665564
300	80	9.5	665574

## End Caps – Tapped

Pipe Dia (mm)	Tap Dia (mm)	l	Nom Weight (kg)	Product Code
50	40 (1 1/2")	30	0.2	665504TE
70	50 (2")	35	0.4	665514TE
100	50 (2")	40	0.9	665524TE
150	50 (2")	50	1.7	665544TE
200	50 (2")	60	3.1	665554TE

## End Caps – Plug

Pipe Dia (mm)	Nominal Weight (kg)	Product Code
100	1.1	664804
125	1.4	664814
150	2.1	664824
200	3.3	664834

## Downpipe Supports

Pipe Dia (mm)	x	d	l	Nom Weight (kg)	Product Code
50	96	87	200	1.3	661544
70	96	106	200	1.6	661554
100	96	145	200	2.3	661564
125	96	170	200	3.0	661574
150	96	105	200	4.0	661584
200	96	245	200	6.0	661594
250	146	340	300	19.5	661604
300	146	390	300	25.5	661614

For use with Stack Pipe Support Bracket. (See page 18 and 40 for details)

## Bearing Rings

Pipe Dia (mm)	d	a	b	c	Nom Weight (kg)	Product Code
50	61	193	25	33	0.8	666314
70	81.5	214	26	33	1.0	666324
100	115	250	28	33	1.3	666334
125	138	275	28	33	1.5	666344
150	163	301	30	33	2.0	666354
200	215	360	30	36	3.0	666374
250	280	442	34	40	5.6	227152
300	332	495	39	40	7.4	227153



## Manifold Connector

Pipe Dia (mm)	d	k	b	l	Nom Weight (kg)	Product Code
100	287	240	66	42	1.8	214089

(See page 46 for details)

## Pipe with Wall Flange

Pipe Dia (mm)	x1	x2	x3	x4	Nom Weight (kg)	Product Code
100	200	400	60	38	8.0	662224

## Sleeved Connectors

Pipe Dia (mm)	d	l	m	Nom Weight (kg)	Product Code
100	144	250	40	3.3	662194
125	172	250	42.5	4.6	662204
150	201	250	45	6.1	662214

## Branch Traps

Pipe Dia (mm)	l	h	w	x1	x2	Nom Wt (kg)	Product Code
50	190	250	60	68	68	2.8	669562
70	265	293	60	93	93	5.5	669563
100	325	392	100	110	110	8.5	669564
125	390	446	100	130	130	13.0	669565
150	470	493	100	145	145	19.5	669566
200	600	500	100	130	210	33.0	669567

## Stoneware Connectors

Pipe Dia (mm)	d	l	m	Nom Weight (kg)	Product Code
100	159	140	70	4.3	664924
125	187	140	70	6.7	664934
150	218	140	70	7.5	664944
200	278	140	70	13.3	664954

For stoneware connection to Harmer SML Pipes use the 'A' ring coupling. For connection from Harmer SML to stoneware with a female end pipe use the 'O' coupling. (See page 30)

## Plain Trap

Pipe Dia (mm)	l	h	x1	x3	Nom Weight (kg)	Product Code
100	370	297	80	55	7.3	100261

## Flanged Connectors

Pipe Dia (mm)	d	k	b	l	Nom Weight (kg)	Product Code
100	220	180	24	150	5.8	665934
125	250	210	26	150	8	665944
150	285	240	26	150	9.8	665954
200	340	295	26	150	14.5	665964

## Rainwater Stench Traps

Pipe Dia (mm)	a	b	c	l	Nom Weight (kg)	Product Code
70	195	90	80	472	9.0	669557
100	276	124	90	588	18.5	669558
125	344	144	100	687	28.5	669559
150	374	179	110	742	38.0	669560

## Pipe Adaptors



### Konfix Single (Waste adaptor)

Pipe Dia (mm)	d1	d2	d3	d4	d5	d6	l	Product Code
50	72	56	48	40	57	66.5	58	100270
70	92	75	63	56	77	85.5	73	100271
100	128	108	104	—	108	116	102.5	100272

### Konfix Multi (Waste adaptor)

Pipe Dia (mm)	d1	d2	d3	d4	d5	d6	l	Product Code
100	134	—	—	—	108	116	90.5	100030

### Rubber Pipe Joints

d1	d2	Product Code
50	28-34	100125
50	38-44	100089

### 'A' Ring Rubber Couplings

Pipe Dia (mm)	Usage	Product Code
100	For use with SML stoneware connectors	100100
125	For use with SML stoneware connectors	100101
150	For use with SML stoneware connectors	100102
200	For use with SML stoneware connectors	100103

### 'O' Ring Rubber Couplings

Pipe Dia (mm)	Usage	Product Code
100	For use with SML stoneware connectors	100111
125	For use with SML stoneware connectors	100112
150	For use with SML stoneware connectors	100113
200	For use with SML stoneware connectors	100114

## Fixing Tools

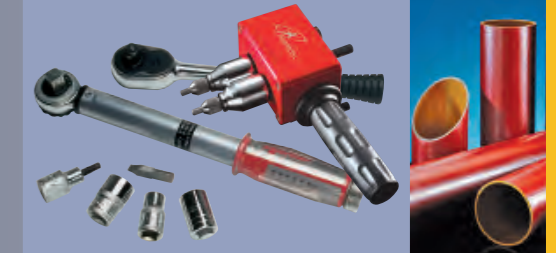

### Harmer Duomat Fixing Tool

Description	Product Code
Harmer Duomat Fixing Tool – 9 Nm torque setting	3900
For use with Stainless Steel Couplings: Duo and Grip (See pages 39 and 48)	

### 1/2" Drive Tools

Description	Product Code
Ratchet Handle 1/2" Drive	110000
Torque Wrench 1/2" Drive - 20 Nm to 40 Nm torque range	110001
10mm 1/2" Drive Socket	110007
13mm 1/2" Drive Socket	110002
18mm 1/2" Drive Socket	110003
19mm 1/2" Drive Socket	110004
5mm Allen Key 1/2" Drive Socket	110008
6mm Allen Key 1/2" Drive Socket	110005
8mm Allen Key 1/2" Drive Socket	110013
10mm Allen Key 1/2" Drive Socket	110012
14mm Allen Key 1/2" Drive Socket	110014
10mm Flat Bit with 3/16" Hexagonal Shank	110006

(See page 48 for further details)

### 3/8" Drive Tools

Description	Product Code
Torque Wrench 3/8" Drive - 4Nm to 20Nm torque range	110009
5mm Allen Key 3/8" Drive Socket	110010
6mm Allen Key 3/8" Drive Socket	110011

(See page 48 for further details)



## Quality Standard

Harmer SML meets the requirements of BS EN 877 and is manufactured under ISO 9001: 2000 Quality Management System (Certificate No.12 100 21864), and is approved under the British Board of Agrément (BBA Certificate No. 05/4191)

## Material

Harmer SML drainage pipe systems are manufactured from grey cast iron according to EN 1561 to a minimum material grade of EN-GJL-150 (EN-JL1020).

## Coatings

Soil and drainage pipe systems have to perform under extremely demanding conditions with domestic effluents containing aggressive cleaning agents and chemicals. The high-quality coating of Harmer SML goes beyond the requirements of BS EN 877 - see chemical resistance table below.

SML drainage pipes are externally protected with anti-corrosive primer coating, which meets fire classification A1. On the inside the pipes are coated with two-part epoxy coating which offers high resistance against chemical and mechanical damage.

### Pipe Coatings

External surface – anti-corrosive primer coating

Colour: Red

Thickness: Minimum of 40 µm

Internal surface – two-part epoxy coating

Colour: Ochre

Thickness: Minimum of 120 µm

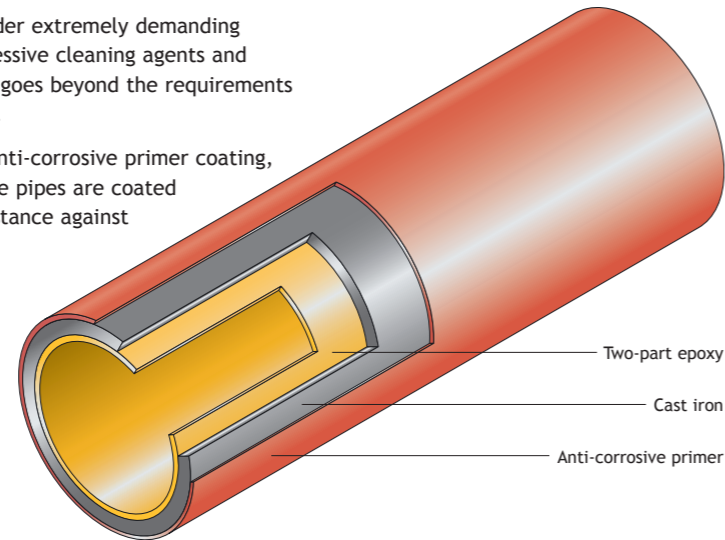

### Fitting Coatings

SML fittings are internally and externally coated with red two-part epoxy coating, dip applied to a thickness of 60 µm.

### Other Coatings

For below ground application and other aggressive conditions, Alumasc offer other coating systems. (See page 69 for details)

Consult Alumasc Technical Department for further details.

## Chemical Resistance of Interior Coatings of SML Pipes

This table applies to applications with intermittent use.

	Liquid	Up to 23°C	Up to 50°C	Up to 80°C
Acidic solutions	pH 0			
	pH 1 (except organic acids)			
	pH 2 (except organic acids)			
	Lime-dissolving substances			
	Cleaning products			
	Detergents			
	Disinfectants			
	Stain removers			
	Oxidants			
	Water (pH 7), salts			
Alkaline solutions	Drain clearing products			
	Solvents			
	pH 12			
	pH 13			
	pH 14			

Conditions where interior coatings meet chemical resistance requirements of BS EN 877

Conditions where interior coatings exceed chemical resistance requirements of BS EN 877

## Pipe Weights and Dimensional Tolerances

Nominal Pipe Dia (mm)	External Dia		Wall Thickness Min	Sealing Zone Min	Pipe Weight (kg/m)	
	Min	Max			Empty	Filled
50	57	60	3.0	30	4.3	6.4
70	77	80	3.0	35	5.9	9.9
100	109	112	3.0	40	8.4	17.7
125	133	137	3.5	45	11.8	24.5
150	158	162	3.5	50	14.1	32.3
200	208	212	4.0	60	23.1	54.6
250	271.5	276.5	4.5	70	33.3	87.7
300	323.5	328.5	5.0	80	43.2	120.8
400	426	431	5.0	80	60.0	196.2

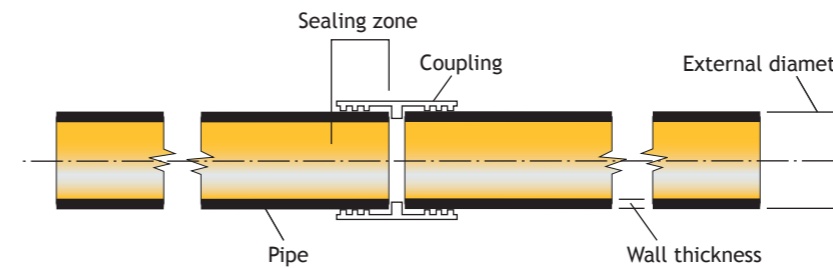

## Product Identification

SML pipes and fittings are labelled during manufacture in accordance with the standard BS EN 877 and can be clearly identified as indicated below.

### Pipe marks

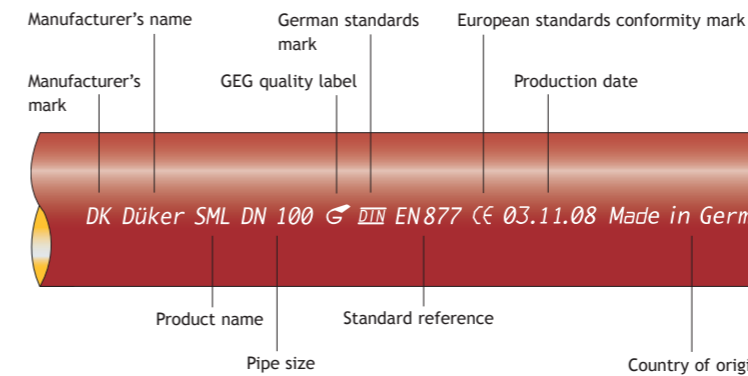

### Fitting marks (both sides)

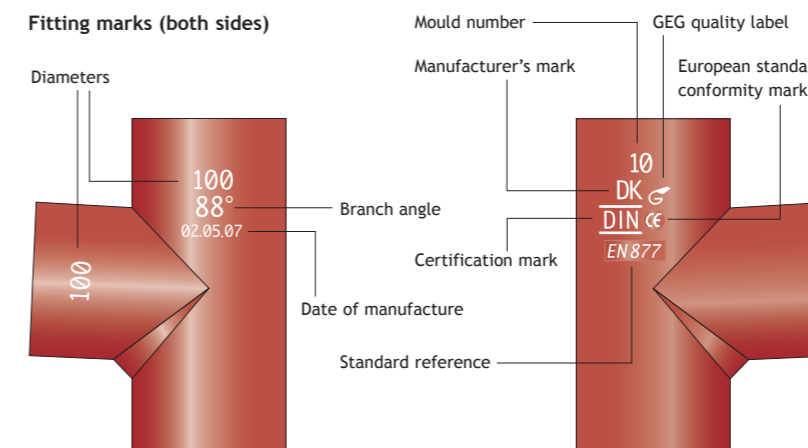

## Tolerance Definitions

### Weights

BS EN 877 stipulates: "The nominal masses of finished products (pipes, fittings and accessories) shall be given in the manufacturers' catalogues. When measured in accordance with Table 5.3 of the standard, the lower deviation shall not exceed 15% of the nominal mass".

### Lengths

In accordance with clause 4.2.9 of BS EN 877, lengths of fittings shall be within a tolerance of ±5mm. Lengths of pipes shall be within a tolerance of ±20mm when measured in accordance with clause 5.2.7 of the standard.

### Sealing zone

Ovality of pipes and the sealing zone of fittings shall remain within the tolerance of the external diameter.

## Flow Capacities of Soil and Waste Systems

Maximum flow capacities (litres per second) of SML pipes, flowing at various gradients, with pipes flowing full (ks value = 0.6).

Pipe Dia (mm)	1:40 (l/s)	1:60 (l/s)	1:80 (l/s)	1:100 (l/s)
50	1.46	1.19	1.03	0.92
70	4.29	3.50	3.03	2.71
100	9.24	7.55	6.54	5.50
125	16.8	13.7	11.9	10.6
150	27.3	22.3	19.3	17.2
200	58.7	47.9	41.5	37.1
250	106.0	86.9	75.2	67.3
300	173.0	141.0	122.0	109.0
400	416.7	339.9	294.1	262.82

System design may limit soil and waste flow rates below these values. Higher flow rates will be possible for rainwater pipework.

For vertical flow capacities refer to BS EN 12056: 2000, Parts 2 and 3.





## Introduction

Harmer SML couplings are available in either ductile iron or stainless steel and meet the requirements of BS EN 877. The internal pressure performance of couplings ranges from 0.5 bar to 10 bar. All couplings feature EPDM elastomeric seals as standard. Neoprene rubber seals are available on request.

The Harmer range of couplings has been put together with the installer in mind. The Harmer Duo and Harmer Grip twin bolt couplings offer quick and easy installation. The couplings are supplied ready to fit onto the pipe, and there is no need to dismantle; simply push fit over the Harmer SML pipe and tighten to the required torque setting. For efficient installation, use the Harmer Duomat Fixing Tool which simultaneously tightens the bolts to the required torque.

(See page 39 for installation details)

## Ductile Iron Couplings

The Harmer SML Ductile coupling is a two-part coupling with an integrated electrical continuity connection. Available in 50 to 200mm diameters the couplings are made from ductile iron grade EH-GJS-400-15 and coated in red epoxy. Incorporating an EPDM gasket, the coupling is bolted together using M8 bolts. The electrical continuity is activated by tightening two screws located on either side of the coupling. (See detail on page 35 and 38)

## Stainless Steel Couplings

The Harmer SML Duo coupling is an earth continuous, above-ground, twin-screw stainless steel coupling available for all Harmer SML pipes and fittings, for pipe connections from 50 to 300mm diameter. The Duo continuity coupling can be used (where required by current legislation) to provide earth continuous conductance through the soil stack. When direct contact of all metal components is required, electrical testing of each joint, as work progresses, is recommended.

The Harmer SML Grip coupling is an earth continuous, above-ground, twin screw stainless steel coupling available in 50mm to 200mm diameter. The Grip coupling can be used as an alternative to the Duo coupling where higher internal pressure performances are required. (See table on page 35)

The Harmer SML Adaptor coupling is used when it is necessary to make a connection between BS EN 877 lightweight cast iron 'soil' systems and conventional cast iron thick wall 'drain' systems. This coupling does not incorporate any provision for electrical continuity.

## High Pressure Couplings

The Harmer SML Combi Grip Collar EK coupling is a security collar that can be used to provide axial resistance up to 10bar.

The Harmer SML Connect-G Inox coupling is used to provide axial restraint up to 10 bar for pipes installed above and below ground.

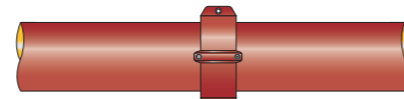

Ductile iron coupling

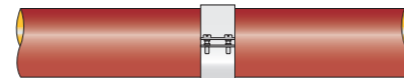

Stainless steel coupling

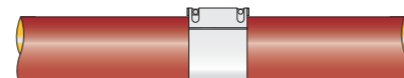

High pressure coupling



Harmer SML Ductile



Harmer SML Duo



Harmer SML Grip



Combi Grip Collar

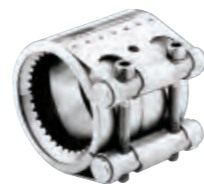

Harmer SML Connect-G Inox

## Couplings Data

Harmer SML Coupling	Material	Type	Dia Range (mm)	Pressure Rating		Torque
				Unrestrained	Restrained*	
Ductile	Ductile iron	Mechanical	50 to 200	0.5 bar	5 bar	20 Nm
Duo	Stainless steel	Mechanical	50 to 300	0.5 bar	50 to 200mm = 5 bar 250 and 300mm = 3 bar	3.5 Nm to 9 Nm
Grip	Stainless steel	Mechanical	50 to 200	50 to 100mm = 3 bar 125mm = 1.5 bar 150 and 200mm = 1 bar	5 bar	7 Nm to 9 Nm
Adaptor	Stainless steel	Mechanical	100 and 150	0.5 bar	5 bar	3.5 Nm to 5.5 Nm
Combi Grip Collar	Galvanised Steel	Mechanical	50 to 300	50 to 100mm = 10 bar 125 to 150mm = 5 bar 250 to 300mm = 1 bar	50 to 100mm = 10 bar 125 to 150mm = 5 bar 250 to 300mm = 1 bar	25 - 65 Nm
Connect-G Inox	Stainless steel	Mechanical	50 to 400	50 to 300mm = 10 bar 400mm = 6 bar	50 to 300mm = 10 bar 400mm = 6 bar	As stated on coupling

\* Fixed to prevent movement.

## Electrical Continuity

The Harmer Ductile, Duo and Grip couplings will satisfy the electrical continuity requirements of the IEE regulations provided that the SML pipework is bonded to an electrical earth and these couplings are assembled, installed and tightened to the correct torque in accordance with our recommendations.

The procedure for testing electrical continuity should be in accordance with the requirements of BS EN 877 as follows:

*'If provision is made for electrical continuity, the electrical resistance of the coupling shall not exceed 0.3 ohms, when tested in accordance with the following procedure: Apply a steadily increasing voltage not exceeding 50V ac, 50 Hz, across the junction until a steady current of 25±1A flows through the coupling. Allow the current to flow for 30 seconds, maintaining it as necessary by adjusting the voltage. Calculate the resistance of the coupling by dividing the observed voltage by the current.'*

The installation should be regularly checked for damage, or when modifications are proposed, to ensure that electrical continuity is maintained.

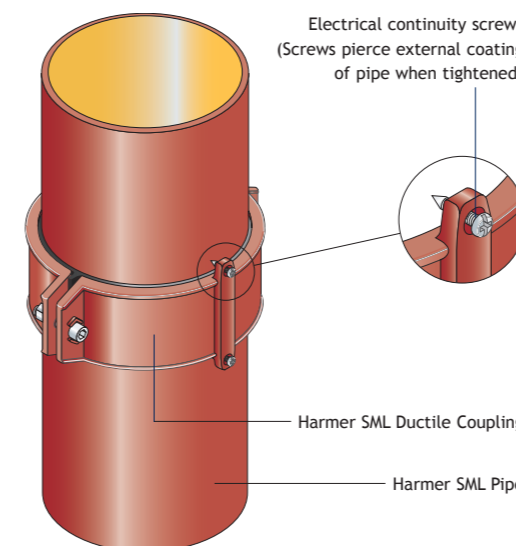

Harmer Ductile Coupling installation

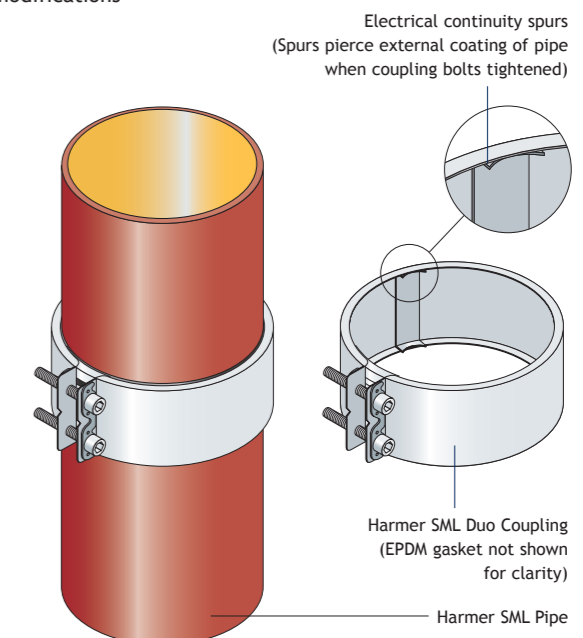

Harmer Duo Coupling installation

**NEW High Pressure Couplings now available please contact Harmer Technical on Tel: 01744 648400 for more information.**

# Technical Data: Brackets

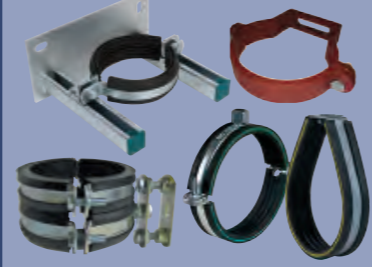

# Technical Data: Brackets



## Introduction

Harmer SML Brackets are available to support above-ground pipework, both vertically and horizontally.

The range comprises vertical and horizontal brackets which are available in either ductile cast iron or zinc plated and fitted with sound deadening rubber linings. Unlined brackets are also available on requested. Please contact Harmer Technical services for details.

## Ductile Cast Iron Bracket

The new all-purpose lightweight ductile iron bracket can be used for vertical and horizontal pipework and removes the need for stack supports.

(See page 40 and 41 for details)

### Features and Benefits

- Elongated slot for fixing, allowing vertical and lateral adjustments
- Lightweight but durable and strong
- Reduce the need for stack supports

## Ductile Cast Iron Bracket

Pipe Dia (mm)	Bolt Size ('S' on drwg)	Bolt Head Type	Safe Load (N / kg)*
50	M8 x 30mm	13mm hexagonal head	640N / 64kg
70	M8 x 30mm	13mm hexagonal head	990N / 99kg
100	M8 x 30mm	13mm hexagonal head	1770N / 177kg
150	M8 x 40mm	13mm hexagonal head	3230N / 323kg
200	M8 x 40mm	13mm hexagonal head	5460N / 546kg

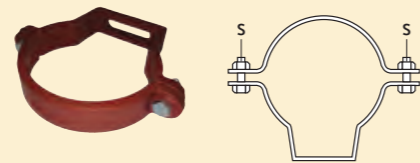

\*Loads stated are pull down loads and apply to vertical pipework

## Optimal Bracket

The Harmer Optimal bracket is a general purpose bracket used for vertical and horizontal restraint of pipes up to 200mm diameter. In vertical applications this bracket must be used in conjunction with a vertical support bracket.

(See page 40 and 41 for details)

### Features and Benefits

- Zinc plated
- Anti-vibration ageing-resistant EPDM rubber lining
- Acoustically tested to BS EN 14366: 2004
- Unique latching device (100mm diameter only)
- Hexagonal headed screw with combi-slot
- M8 - M10 dual tapped boss

## Optimal Bracket Data

Pipe Dia (mm)	Connecting Boss ('G' on drwg)	Bolt Size ('S' on drwg)	Bolt Head Type	Safe Load (N / kg)*
50	M8 / M10	M6 x 25	10mm hexagonal head with combi slot	1490N / 149kg
70	M8 / M10	M6 x 25	10mm hexagonal head with combi slot	1490N / 149kg
100	M8 / M10	M6 x 25	10mm hexagonal head with combi slot	2170N / 217kg
125	M8 / M10	M6 x 25	10mm hexagonal head with combi slot	2170N / 217kg
150	M10	M6 x 35	13mm hexagonal head with slot	2170N / 217kg
200	M10	M6 x 35	13mm hexagonal head with slot	2170N / 217kg

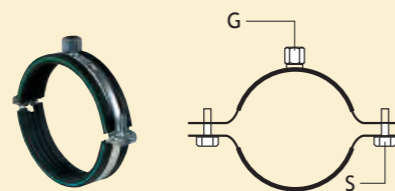

\* Loads stated are pull down loads and apply to horizontal pipework applications only. When used in vertical applications additional stack support is required.

## Optimal HD Bracket

The Harmer Optimal HD bracket is a robust bracket suitable for vertical and horizontal restraint of pipes up to 300mm diameter. In vertical applications this bracket must be used in conjunction with a vertical support bracket.

(See page 40 and 41 for details)

### Features and Benefits

- Zinc plated
- Ageing-resistant EPDM rubber lining
- Acoustically tested to BS EN 14366: 2004
- Captive locking nut with anti-loss washer for ease of installation (up to and including 125mm)
- CO<sub>2</sub> welded connection boss
- M10 - M12 dual tapped boss (up to and including 200mm)

## Optimal HD Bracket Data

Pipe Dia (mm)	Connecting Boss ('G' on drwg)	Bolt Size ('S' on drwg)	Bolt Head Type	Safe Load (N / kg)*
100	M10 / M12	M8 x 35	13mm hexagonal head	2800N / 280kg
125	M10 / M12	M8 x 35	13mm hexagonal head	2800N / 280kg
150	M10 / M12	M10 x 40	17mm hexagonal head	3900N / 390kg
200	M10 / M12	M12 x 50	19mm hexagonal head	3900N / 390kg
250	M16	M12 x 50	19mm hexagonal head	6500N / 650kg
300	M16	M12 x 50	19mm hexagonal head	6500N / 650kg

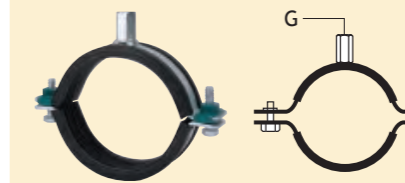

\* Loads stated are pull down loads and apply to horizontal pipework applications only. When used in vertical applications additional stack support is required.

## Stack Pipe Support Bracket

The Harmer Stack Pipe Support bracket is suitable for supporting vertical pipework up to 200mm diameter. The bracket consists of a cantilever arm and a two-part rubber lined clamp. Harmer Downpipe Support fitting must also be used in conjunction with this bracket.

(See page 40 for installation details)

### Features and Benefits

- Zinc plated
- CO<sub>2</sub> welded cantilever arm
- Ageing resistant EPDM rubber lining
- Adjustable distance between pipe and wall

## Stack Pipe Support Bracket Data

Pipe Dia (mm)	Connecting Nut ('G' on drwg)	Clamp Bolt Size	Bolt Head Type	Safe Load Fy (N / kg)*
70	M8 x 16	M8 x 25	13mm hexagonal head with slot	3000N / 300kg
100	M8 x 16	M8 x 25	13mm hexagonal head with slot	3000N / 300kg
125	M8 x 16	M8 x 25	13mm hexagonal head with slot	3000N / 300kg
150	M8 x 16	M8 x 25	13mm hexagonal head with slot	3000N / 300kg
200	M8 x 16	M8 x 25	13mm hexagonal head with slot	3000N / 300kg

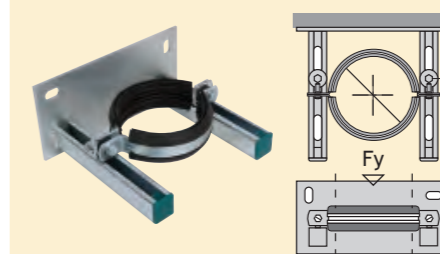

\* Safe load is measured at 130mm from wall to centre of clamp/pipe.  
\* Please see page 40 for installation recommendation with SML pipework.  
Please contact Alumasc Technical Services for information on stack pipe support systems for pipework above 200mm diameter.

## Stand Pipe Support Bracket

The Harmer Stand Pipe Support bracket is suitable for supporting vertical pipework up to 150mm diameter. The bracket consists of a two-point wall plate assembly with lateral adjustment and a twin pipe-clamp assembly.

(See page 41 for installation details)

### Features and Benefits

- Zinc plated
- CO<sub>2</sub> welded
- Ageing resistant EPDM rubber lining
- Lateral adjustment

## Stand Pipe Support Bracket Data

Pipe Dia (mm)	Connecting Nut ('G' on drwg)	Clamp Bolt Size	Bolt Head Type	Safe Load Fy (N / kg)*
70	M10 with 17mm hexagonal nut	M8 x 25	13mm hexagonal head with combi slot	650N / 65kg
100	M10 with 17mm hexagonal nut	M8 x 25	13mm hexagonal head with combi slot	820N / 82kg
125	M10 with 17mm hexagonal nut	M8 x 25	13mm hexagonal head with combi slot	820N / 82kg
150	M10 with 17mm hexagonal nut	M8 x 25	13mm hexagonal head with combi slot	820N / 82kg

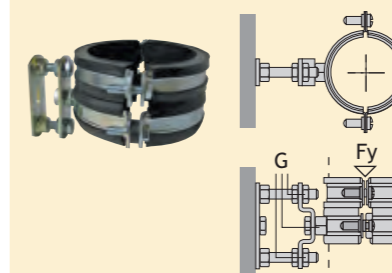

\* Please see page 41 for installation recommendation with SML pipework.

## Installation: Ductile Iron Coupling



1. Slacken the bolts on the Ductile Iron coupling, fully removing one bolt completely. Remove the EPDM rubber gasket.



2. Push the EPDM rubber gasket over the end of the pipe or fitting ensuring that the central inner register is abutted against the spigot end.



3. Ease the next pipe or fitting into the EPDM rubber gasket making sure that the spigot end is against the central inner register.



4. Loosely fit the coupling around the gasket, ensuring that the rubber lip sits into the corresponding locator in the coupling. The electrical continuity screws should be drawn back to fullest extent to avoid interference with the connecting pipe or fitting.



5. Check the alignment of the assembly before tightening the bolts. Alternately tighten the bolts to ensure that the coupling is aligned evenly. Bolts should be tightened until a reasonable resistance is achieved - recommended torque setting 20 Nm.



6. For electrical continuity, handtighten the electrical continuity screws on both sides. Ensure screws pierce external coating of pipe when tightened. (See page 35)

All Ductile iron couplings use an M8 bolt and require a 6mm allen key. The coupling incorporates an anti-turn feature which holds the bolt nut in place without the need for a secondary tool. (See page 31 and 48 for details of fixing tools)



## Installation: Stainless Steel Coupling



1. Harmer Duo couplings are supplied factory assembled and ready to fit.



2. Ease-in one side (next to the continuity spur) then push down on the opposite side of the coupling to fully seat, ensuring that the central inner register is abutted against the spigot end.



3. Ease the next pipe or fitting into the coupling as step 2.



4. Evenly tighten the bolts to the required torque setting. The coupling should only be tightened once because it can not be dismantled and re-used. (See Couplings Specification page 34)



5. The Harmer Duomat fixing tool is recommended for securing Harmer Duo couplings. Bolts can be tightened simultaneously with precision.



Torque wrench, ratchet handle and sockets

A complete range of high quality fixing tools is available from Alumasc. (See pages 31 and 48 for details)

Note:  
Harmer Duo, Grip and Adaptor couplings require a 5mm allen key.



Duomat tool

# Installation: Vertical Pipe Support



## Support for Vertical Pipework

Vertical pipework must be supported with a load bearing bracket to carry the weight of the pipe and its contents. (See page 33 for filled pipe weights)  
The purpose of these load bearing brackets is to support the stack as it is built up to prevent downward movement of the pipe and unnecessary load at the base of the stack, and to maintain expansion gaps.

It is recommended that Harmer SML is supported either using Ductile Cast Iron Brackets or Stack Pipe Support Brackets in combination with Optimal brackets as shown below. Alternatively, Stand Pipe support Brackets can be used. (See details on page 41)

Connections joining the vertical stack should also be adequately supported above and below every branch. The vertical pipe should be fixed not closer than 30mm to the wall to allow maintenance and painting of the pipe.

## Stack Pipe Support Brackets

A Stack Pipe Support Bracket must be provided at basement level and thereafter as recommended in the table below. Typically a 100mm pipe in a building with an average of 2.5m floor to ceiling height will need to be supported every fifth floor. In addition, Harmer Optimal Brackets should be installed at maximum 2m centres as illustrated.

## Ductile Iron Bracket Supports

Ductile Iron bracket supports can be used for vertical waste and rainwater stacks without the need for Stack Supports. These must be installed at 3 metres max centres and should be tightened as the stack is built up through the floors to make sure that it becomes a self-supporting system and reduces the risk of increase pressure affecting the base of the stack.

## Stack Pipe Support Bracket Centres (when using optimal brackets)

Nominal Pipe Dia (mm)	Weight/m (filled) (kg)	Stack Pipe Safe Load* (N/kg)	Theoretical Clamp Centres (m)	Recommended Clamp Centres**
70	9.9	3000N / 300kg	30.3	1 every 5th floor
100	17.7	3000N / 300kg	16.9	1 every 5th floor
125	24.5	3000N / 300kg	12.2	1 every 3rd floor
150	32.3	3000N / 300kg	9.3	1 every 3rd floor
200	54.6	3000N / 300kg	5.5	1 every 2nd floor

\*Safe load is measured at 130mm from wall to centre of pipe; increasing this distance will reduce the safe load. \*\*Assumes 2.5m storey height



Harmer Optimal Bracket shown with Wall Plate



Stack Pipe Support Bracket shown with SML Downpipe Support

## Vertical Support Using Stack Pipe Bracket

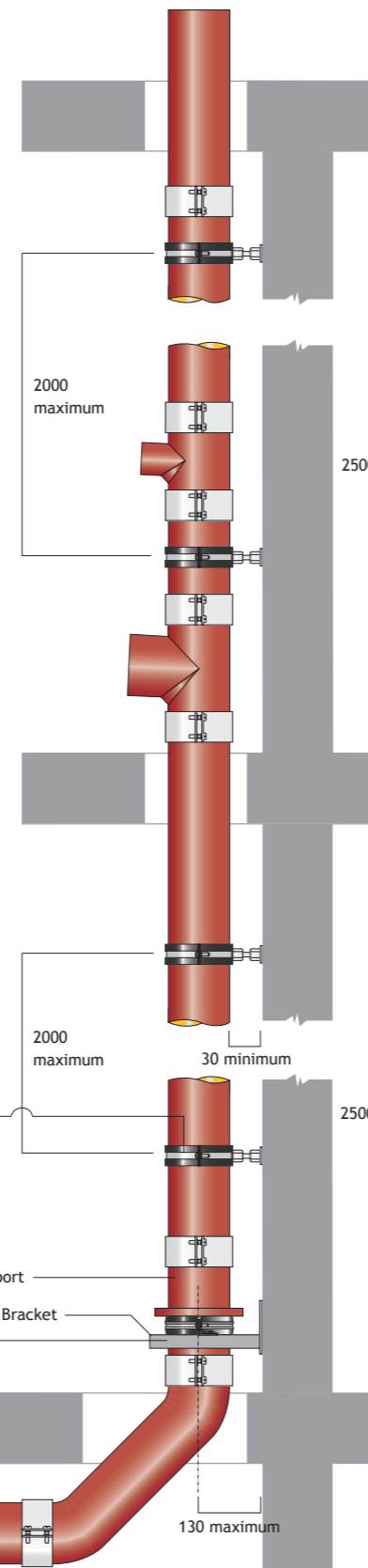

# Installation: Vertical Pipe Support



## Stand Pipe Support Brackets

### When to use stand pipe bracket

When using the NEW Ductile Cast Iron Brackets	NO ❌
When using the Optima; Bracket Data	YES ✅
When using the Optimal HD Bracket Data	YES ✅

The Stand Pipe Support Bracket is an alternative vertical pipe support bracket and can be used where site conditions do not permit the use of the Stack Pipe Support Bracket. The number of Stand Pipe Support Brackets needed varies according to the stack weight. The table below gives details of the maximum distance between each bracket.

## Stand Pipe Support Bracket Centres

Nominal Pipe Dia (mm)	Weight/m (filled) (kg)	Stand Pipe Safe Load (N/kg)	Theoretical Clamp Centres (m)	Recommended Clamp Centres*
70	9.9	650N / 65kg	6.6	1 every 2nd floor
100	17.7	820N / 82kg	4.6	1 every 2nd floor
150	32.3	820N / 82kg	2.5	1 every floor

\*Assumes 2.5m maximum storey heights

### IMPORTANT

Where Stand Pipe Support Brackets are over 2m centres, additional Harmer Optimal Brackets should be installed to support pipework at maximum 2m centres.



Harmer Optimal Bracket shown with Wall Plate



Stand Pipe Support Bracket

## Vertical Support Using Stand Pipe Bracket

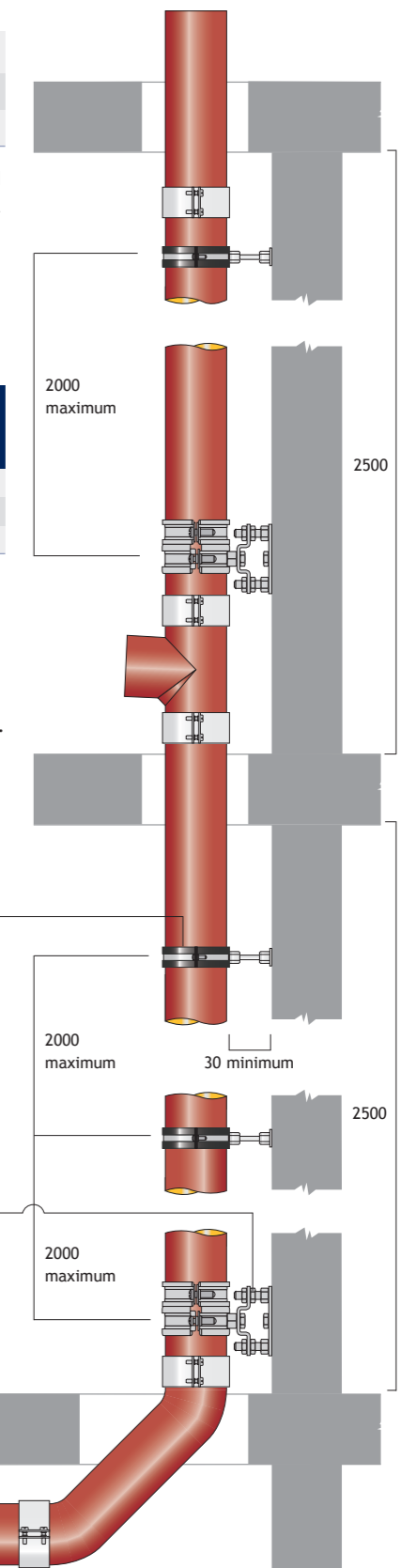

# Installation: Horizontal Pipe Support

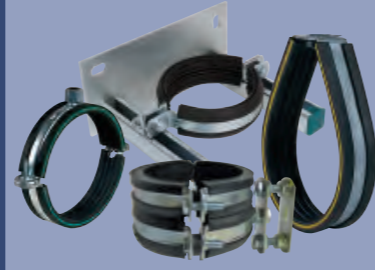

## Support for Horizontal Pipework

Horizontal pipework should be laid to a minimum fall of 20mm per metre, and feeder pipes should be connected to the main pipe using a 45 degree branch in the direction of the flow. Refer to BS EN 12056-2: Code of Practice for Sanitary Pipework for details.

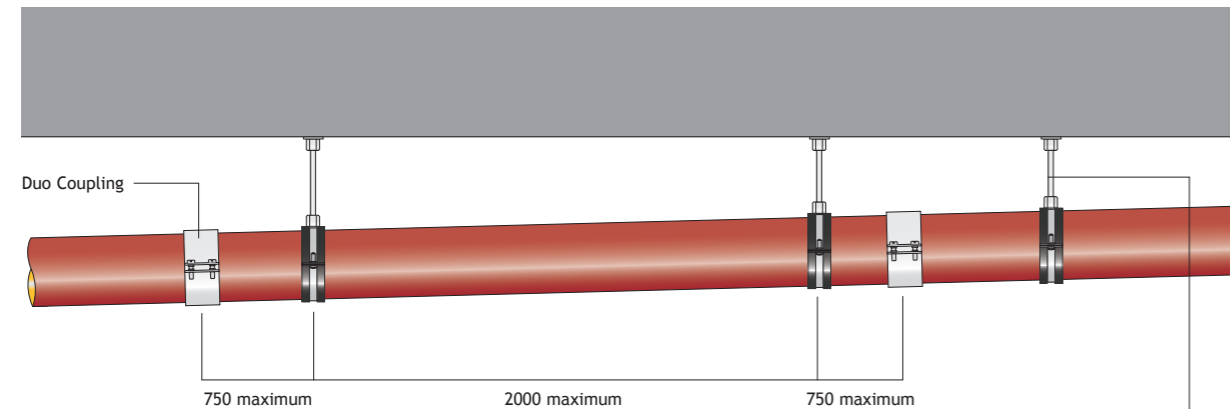

It is recommended that each pipe length in a horizontal pipe run should be supported by 2 brackets, not more than 2m apart. The length of pipe between a bracket and a coupling should not exceed 750mm.

The pipe should be supported at every change in direction or branch. At every 10-15m, a fixing arm should be attached to a bracket to prevent pendular movement of the pipe run. See detail below.



Harmer Optimal Bracket

### Harmer SML horizontal bracket and fixing arm

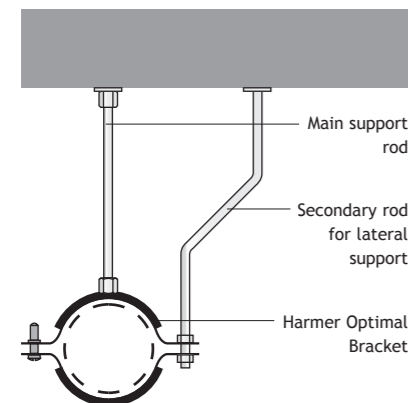

The requirement for pendular restraint may be removed if the pipework has branches entering at 45 or 90 degrees which are supported by at least two hangers.

### Alternative arrangement for pipework with drop length over 1 metre.

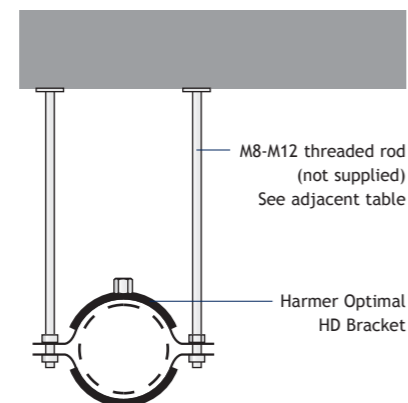

### Threaded Rod Data

Optimal HD Bracket	Threaded Rod Diameter
100	8
125	8
150	10
200	12
250	12
300	12

All dimensions are in mm.

(See Brackets Specification on pages 17 and 18 for details of safe load weights of brackets)

# Installation: Acoustic Protection

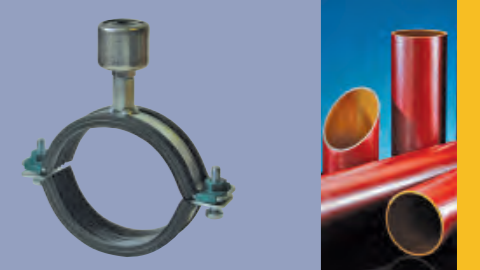

## Introduction

The discharge of soil, waste and rainwater through a pipe generates structure-borne and airborne sound between habitable spaces and usually occurs because the pipe is filled with a mixture of air and water. The resultant noise will then be transmitted to lightweight ceilings, cupboards and similar constructions.

Cast iron pipe systems however, because of the high mass per unit area of their pipe walls as well as the joint design characteristics, provide considerable noise reduction benefits when discharging soil, waste and rainwater within buildings.

## Testing and Certification

BS EN 14366: 2004: *Laboratory measurement of noise from waste water installations* sets out a common test method by which airborne and structure-borne noise emitted by installed discharge systems is measured. Harmer SML has been independently tested to this new standard as certified by the Fraunhofer Institute of Building Physics – test report P-BA 164/2008e and P-BA 165/2008e. See table below.

BS 8233: *Code of Practice for Sound Insulation and Noise Reduction for Buildings*, provides guidelines for indoor ambient noise levels for various room uses. The general requirement for residential/habitable rooms is 30-35 dB; the lowest design range is 20-25 dB for recording studios. The Harmer SML system is able to meet these low levels of acoustic performance.

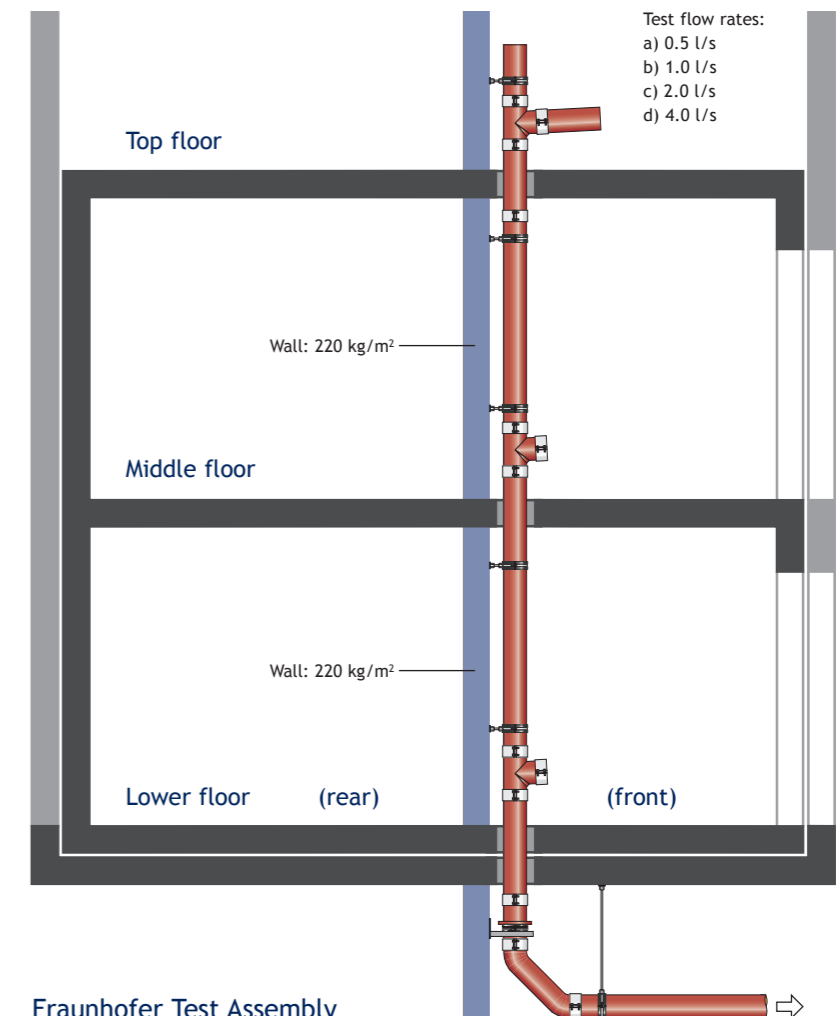

### Fraunhofer Test Assembly

The Fraunhofer Institute of Building Physics test facility is constructed to a 220 kg/m² wall density. One of the most important parameters in the context of Structural-borne sound is wall density, as changes can greatly affect the installation sound level. For example, a wall density reduced to 140 kg/m² gives an increase in laboratory acoustic measurement of 4 dB at 4 l/s. It should be noted that test data conducted in a controlled laboratory cannot be transferred to other building conditions without restrictions.

## Test Data

Pipe and Bracket Type (see drawing)	Airborne Sound Pressure Level $L_{p,a}$ [dB(A)] (see note a)				Structure-borne Sound Characteristic Level $L_{w,c,A}$ [dB(A)] (see note b)				Number of Brackets Used	Wall Density (kg/m²)
	Flow rate	0.5 l/s	1.0 l/s	2.0 l/s	4.0 l/s	0.5 l/s	1.0 l/s	2.0 l/s		
1. Harmer SML with Optimal rubber-lined brackets	–	–	45	48	–	–	22	27	2	220
2. Harmer SML with Optimal rubber-lined brackets and spacers	39	43	45	48	9	14	19	24	2	220
3. Harmer SML with Optimal rubber-lined brackets with acoustic dampener (dB Fix) and Wall Plate	38	43	45	47	5	9	14	19	2	220

(a) Lower floor: front (b) Lower floor: rear

# Installation: Connection to Other Materials



# Installation: Connection to Other Materials



## Introduction

The Harmer SML range can be connected to waste pipes using a number of purpose-made connectors as detailed below. It is recommended that a suitable pipe lubricant be used when connecting into a push-fit joint. All connectors are available from stock.

## Konfix Single

Suitable for making a single connection from 50-100mm Harmer SML to any drainage material within the size range shown (see table). The Konfix push-fit EPDM adaptor pushes over the receiving pipe and is secured with a stainless steel circlip. The hole for the connecting pipe is created by simply pulling on the pull-out tab which exposes the hole for the connecting material. The connecting pipe must be fixed in order to avoid slippage from internal pressure.

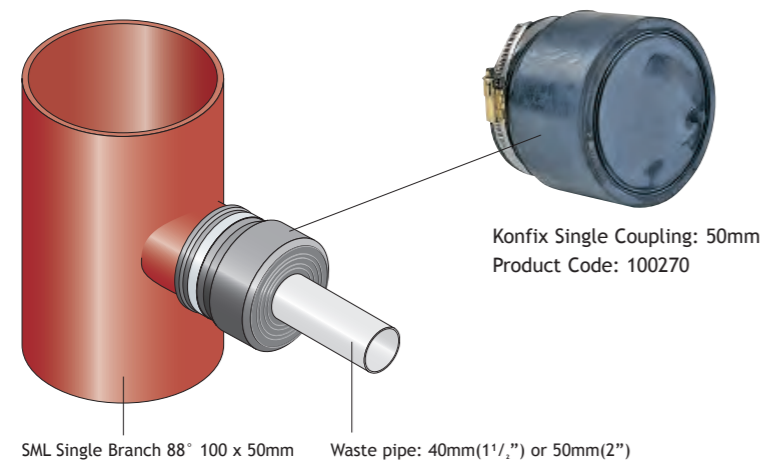

## Konfix Single Data

SML Pipe Dia	Connecting Pipe Dia	Insertion Depth	Product Code
50	40-56	42	100270
70	56-75	55	100271
100	104-110	65	100272

All dimensions are in mm.

## Konfix Multi

Allows up to 3 connections to Harmer SML 100mm pipework (see table for size range). The Konfix push-fit EPDM adaptor pushes over the receiving pipe and is secured with a stainless steel circlip. The holes for the connecting pipes are created by using a knife to cut into the appropriate groove. The connecting pipes must be fixed in order to avoid slippage from internal pressure.

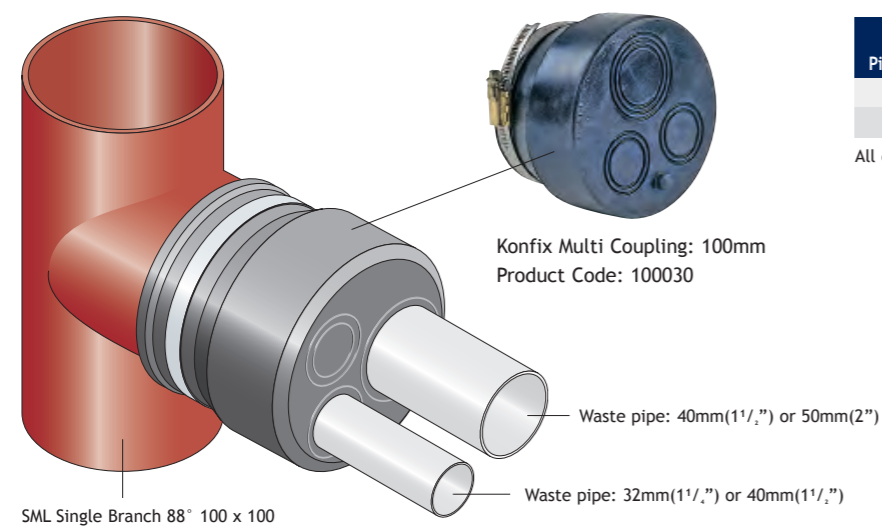

## Konfix Multi Data

SML Pipe Dia	Connecting Pipe Dia	Insertion Depth	Product Code
100	2 x 32-40	40	100030
	1 x 40-56		

All dimensions are in mm.

## Rubber Joint (Boss)

Allows connection from Harmer SML 50mm pipework to 28-44mm pipework, for example 40mm(1 1/2") plastic waste pipe. The rubber joint simply pushes into the receiving pipe allowing a smaller diameter pipe to be pushed into the rubber joint.

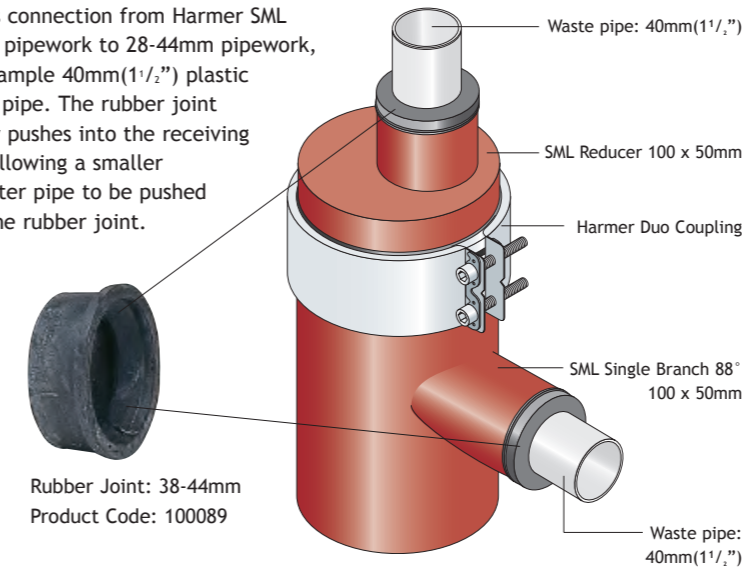

## Rubber Joint (Boss)

SML Pipe Dia	Connecting Pipe Dia	Insertion Depth	Product Code
50	28-34	40	100125
50	38-44	40	100089

All dimensions are in mm.

## Tapped End Cap

An end capped, drilled and tapped to 2" BSP, allowing direct connection to a 2" male BSP threaded pipe or to other pipe size using a 2" BSP male iron adaptor (supplied by others).

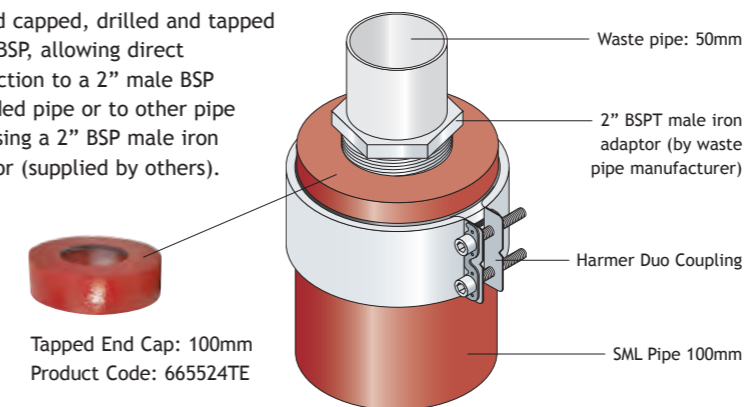

## Tapped End Cap Data

SML Pipe Dia	Product Code
50	665504TE*
70	665514TE
100	665524TE
150	665544TE
200	665554TE

All dimensions are in mm.  
\*Tap diameter is (1 1/2") BSP

## Boss Pipe

Available in 100mm and 150mm dia, boss pipes are drilled and tapped to 2" BSPT. 100mm boss pipes are available in single, double or corner versions, 150mm boss pipe is available with single and double boss. (See page 26 for details)

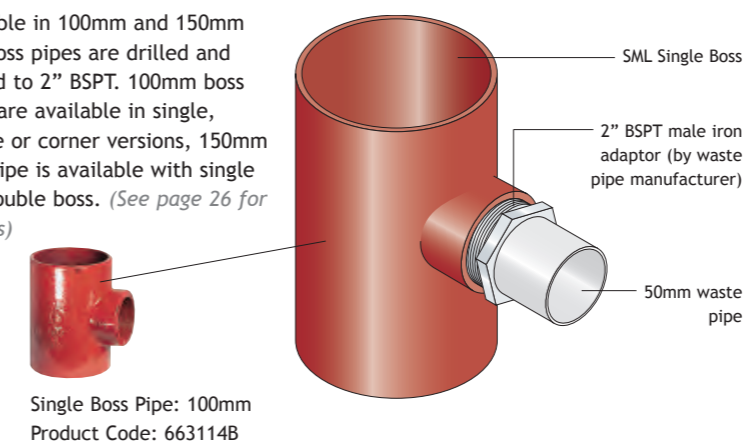

## Boss Pipe Data

SML Pipe Dia	Type	Product Code
100	Single	663114B
100	Double	663114DB
100	Corner	663114CB
150	Single	232746
150	Double	237738

All dimensions are in mm.

# Installation: Manifold Connection



## Introduction

The Harmer SML Manifold Connector eases waste connection by allowing up to 4 connections into this compact manifold. The Manifold Connector is available in 100mm dia and can be connected directly onto a 100mm dia Harmer SML pipe stack using any standard couplings. Waste pipework from various sources such as basins, urinals, baths and showers can be conveniently connected to a singular point above the finished floor level.

The Manifold Connector incorporates four rubber grommets which will permit the connection of 32mm(1 1/4") or 40mm(1 1/2") plastic waste pipes.

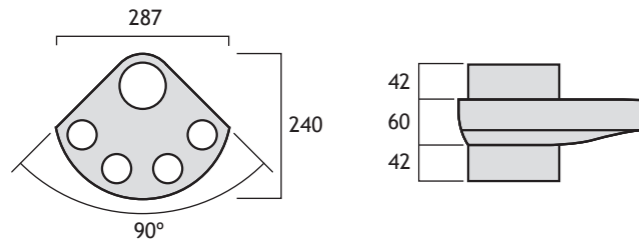

## Installation Guidelines

### Installation of Manifold Connector

The Manifold Connector body is connected to the stack using standard couplings.

### Installation of plastic pipe ends

1. Remove the grommets and pierce the appropriate groove for 32mm(1 1/4") or 40mm(1 1/2") waste connections.
2. Apply appropriate silicon sealant (not provided) to the outside of the grommet and re-fit into the Manifold Connector, making sure that the groove of the grommet is placed correctly in the casing. Ensure sealant is cured before air testing.
3. Lubricate the pipe ends with an appropriate lubricant and insert them into the grommets with a rotational movement. The pipe ends may be chamfered for ease of insertion.

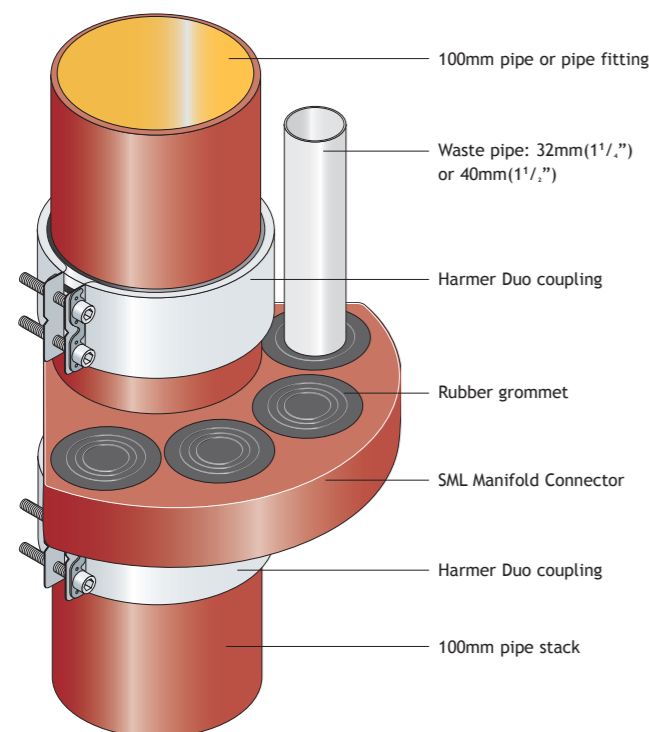

# Installation: Other Connections



## Stoneware Connections

### WC Connection

WC connections can be made by using the Harmer SML Stoneware Connector. Alternatively, Harmer SML will accommodate flexible push-fit type connectors.

### Clayware

Connect Harmer SML to clayware by using Harmer SML Stoneware Connector with a traditional cement joint.

### Traditional Soil

Connect Harmer SML to traditional soil by using Harmer SML Stoneware Connector with a traditional caulked joint.



Stoneware Connector

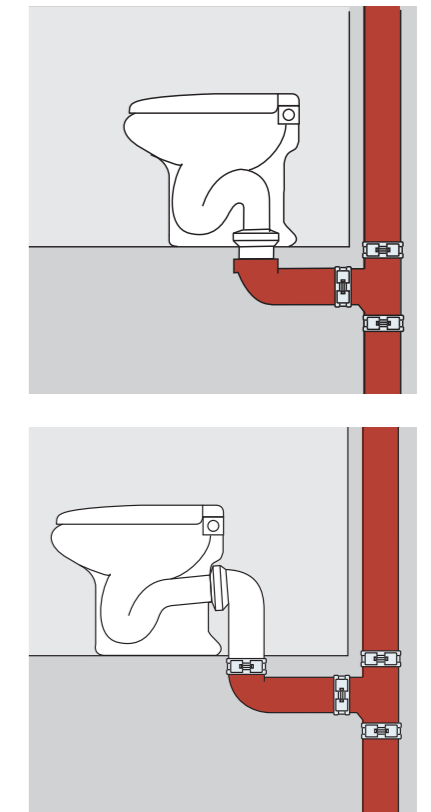

## Roof Connections

### Projections Through Roof

Where a vent pipe projection occurs through a roof slab with mastic asphalt, the waterproofing must be dressed with a weathering collar to a height at least 150mm above the roof surface.

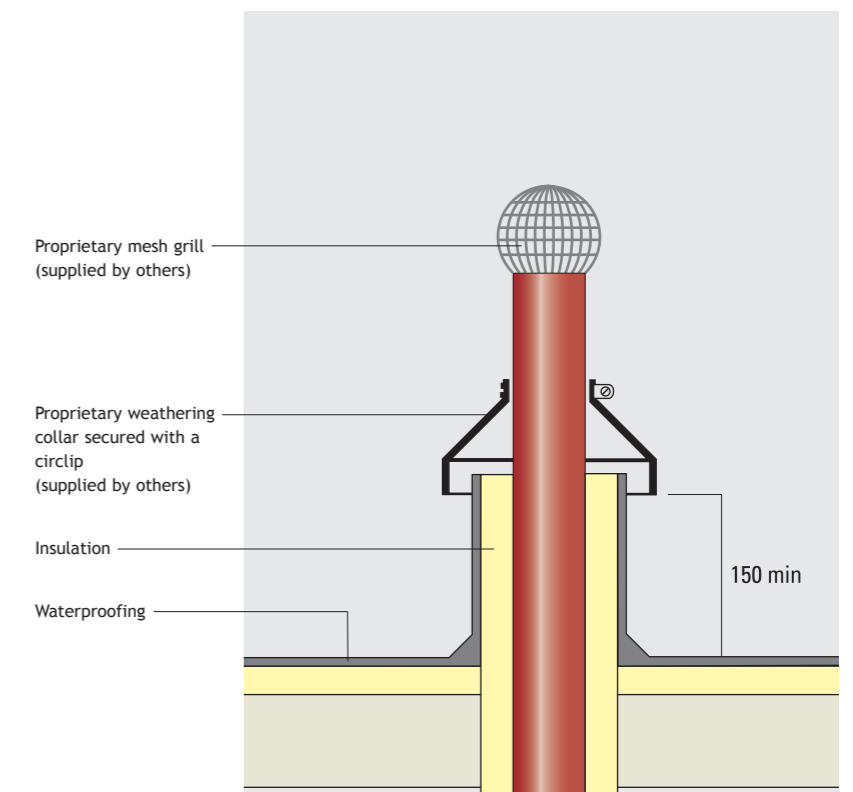



## Fixing Tools

Drive Type	Product Code	Description	For Use With
1/2" Drive	3900	Harmer Duomat Torque Chuck	Stainless Steel Couplings
	110000	Ratchet Handle 1/2" Drive	For use with 1/2" Drive
	110001	Torque Wrench 1/2" Drive - 20Nm to 40Nm torque range	Couplings with 20Nm to 40Nm torque range
	110007	10mm 1/2" Drive Socket	Harmer Optimal Bracket
	110002	13mm 1/2" Drive Socket	70, 100, 150mm Access Bends, Swept Entry Branches, End Caps, Branch Traps
	110003	18mm 1/2" Drive Socket	150mm Access Pipe Rectangular Door, Branch Trap
	110004	19mm 1/2" Drive Socket	All pipe sealing flanges
	110008	5mm Allen Key 1/2" Drive Socket	Stainless Steel Couplings
	110005	6mm Allen Key 1/2" Drive Socket	Ductile Iron Couplings
	110013	8mm Allen Key 1/2" Drive Socket	70, 100mm Connect-G Coupling
	110012	10mm Allen Key 1/2" Drive Socket	125, 150mm Connect-G Coupling
3/8" Drive	110014	14mm Allen Key 1/2" Drive Socket	200-400mm Connect-G Coupling
	110006	10mm Flat Bit with 1/16" Hexagonal Shank	General purposes
	110009	Torque Wrench 3/8" Drive - 4Nm to 20Nm torque range	Couplings with 4Nm to 20Nm torque range
	110010	5mm Allen Key 3/8" Drive Socket	Stainless Steel Couplings
	110011	6mm Allen Key 3/8" Drive Socket	Ductile Iron Couplings

## Duomat Fixing Tool

Suitable for all power tools, the Duomat Fixing Tool is recommended for securing Harmer SML couplings. Bolts can be tightened simultaneously with precision. For details of availability please contact Alumasc.



## Cutting Pipes

Harmer SML pipe can be readily cut by the use of a powered disc cutter, portable bandsaw, wheel cutter or with chain cutters. Ensure the correct grade of disc appropriate to cast iron is used for disc-cutter. Coat cut ends of pipes with appropriate touch-up paint (available on request).

Observe the Health and Safety guidelines from the cutting tool manufacturer's operation manual.

Standard specification guidelines for a 100mm diameter Harmer SML soil and waste system are provided below. NBS format specifications (R11 Above-Ground Foul Drainage Systems) are available for download on the Alumasc website.

### Above-Ground Foul Drainage Systems

Inclusive of sanitary and floor drainage outlets; waste pipework; discharge stack and branch pipework; separate ventilating pipework; accessories and disposal.

### System Performance

Design to comply with BS EN 12056: 2000, Parts 1, 2 and 5.

### Products

**Harmer SML:** Cast iron pipework for internal use.

**Manufacturer:** Alumasc Exterior Building Products Ltd, St Helens, Merseyside WA9 4JG.

**Pipes and fittings:** To BS EN 877 with flexible joint couplings, Agrément certified.

**Accessories:** As required.

**Size:** 100mm diameter.

**Method of fixing:** Bracket fixed at maximum 2.0m centres when horizontal, but pipe projection beyond each bracket should not exceed 750mm. Pipe should be supported at every change of direction or branch and every 15m a fixing arm should be attached. Horizontal pipeline must be laid to a minimum 20mm per metre fall. Feeder pipes should be connected to the main pipe using a 45° branch connector in the direction of flow. Bracket fixed at 2.0m centres when vertical supported with a load bearing bracket at every floor adequately supported above and below every branch. Pipes should not be fixed closer than 30mm to a wall. For building of five or more floors plus basement, with an average 2.5m per floor, a downpipe support fitting must be provided at the basement level and every additional fifth floor.

### Execution

**General installation:** To BS EN 12056: 2000, Parts 1, 2 and 5.

**Components:** From the same manufacturer for each type of pipework.

**Electrolytic corrosion:** Avoid contact between dissimilar metals where corrosion may occur.

**Allowance for thermal and building movement:** Provide and maintain clearance as fixing and jointing proceeds.

**Concealed or inaccessible surfaces:** Decorate before starting work specified in this section.

**Protection (purpose made temporary caps):** Fit to prevent ingress of debris.

**Protection (access covers, cleaning eyes and blanking plates):** Fit as the work proceeds.

### Pipe Routes

**General:** The shortest practicable, with as few bends as possible.

**Short radius bends in wet portion of soil stacks:** Not permitted.

**Routes not shown on drawings:** Submit proposals before commencing work.

### Fixing Pipework

**Pipework:** Fix securely plumb and/or true to line. Fix discharge stack pipes at or close below socket collar or coupling.

**Branches and low gradient sections:** Fix with uniform and adequate falls to drain efficiently.

**Externally socketed pipes and fittings:** Fix with sockets facing upstream.

**Additional supports:** Provide as necessary to support junctions and changes in direction.

**Vertical pipes:** Provide a load bearing support not less than every storey level. Tighten fixings as work proceeds so that every storey is self supporting.

**Wall and floor penetrations:** Isolate pipework from structure, e.g. with pipe sleeves.

**Masking plates:** Fix at penetrations if visible in the finished work.

**Expansion joint sockets:** Fix rigidly to the building. Fixings: Allow the pipe to slide.

### Jointing Pipework - Generally

**General:** Joint with materials, fittings and techniques that will make effective and durable connections.

**Jointing differing pipework systems:** With adaptors intended for the purpose.

**Cut ends of pipes:** Clean and square. Remove burrs and swarf.

**Jointing or mating surfaces:** Clean immediately before assembly.

**Junctions:** Form with fittings intended for the purpose.

**Jointing material:** Do not allow it to project into bore of pipes and fittings.

### Jointing Pipework

**Cast iron, flexible couplings jointing:** Paint cut ends of pipes.

### Coated Pipes

**Cutting:** Recoat bare metal.

### Electrical Continuity

**Joints in metal pipes with flexible couplings:** Make with clips (or suitable standard pipe couplings) supplied for earth bonding by pipework manufacturer to ensure electrical continuity.

### Identification of Internal Foul Drainage Pipework

**Markings:** To BS 1710.

**Type:** Integral lettering on pipe wall, self-adhesive bands or identification clips.

**Locations:** At 500 mm centres, junctions and both sides of slabs, valves, appliances, bulkheads and wall penetrations.

### Discharge and Ventilating Stacks

**Terminations:** Perforated cover or cage that does not restrict airflow.

**Material:** Stainless Steel, uPVC or HDPE.



### Installing Air Admittance Valves

**Position:** Vertical, above flood level of highest appliance served and clear of insulation materials (other than the manufacturer's insulating cover).

**Connection to discharge stack:** Allow removal for rodding, e.g. ring seal.

**Roof spaces and other unheated locations:** Fit manufacturer's insulating cover.

### Access for Testing and Maintenance

**General:** Install pipework with adequate clearance to permit testing, cleaning and maintenance, including painting where necessary.

**Access fittings and rodding eyes:** Position to avoid obstruction.

### Completion and Testing

**Dates for testing:** Give minimum of 3 days notice.

**Pipework preparation:** Securely fixed and free from obstruction and debris.

**Traps preparation:** Filled with clean water.

**Testing:** Supply clean water, assistance and apparatus. Do not use smoke to trace leaks.

**Records:** Submit a record of tests.

### Pipework Airtightness Test

**Open ends of pipework:** Temporarily seal using plugs.

**Test apparatus:** Connect a 'U' tube water gauge and air pump to pipework via a plug or through trap of an appliance.

**Testing:** Pump air into pipework until gauge registers 38 mm.

**Required performance:** Pressure of 38 mm is to be maintained without loss for at least three minutes.

### Siphonage and Back Pressure Tests

**WC pans:** Test by flushing.

**Other appliances:** Test by filling to overflow level, then removing the plug.

**Number of tests:** Test each appliance three times. Recharge traps before each test.

**Self siphonage testing:** Test each appliance individually.

**Induced siphonage and back pressure testing:** Test by discharging the following numbers of appliances simultaneously on each stack:

- WCs; Washbasins; Sinks: To be confirmed by employers agent
- Selection of appliances: Submit proposals.

### Pre-handover Checks

**Temporary caps:** Remove.

**Permanent blanking caps, access covers, rodding eyes, floor gratings and the like:** Secure complete with fixings.

# Harmer Drainage Outlets and Adaptors



# Harmer Aluminium Roof Outlets

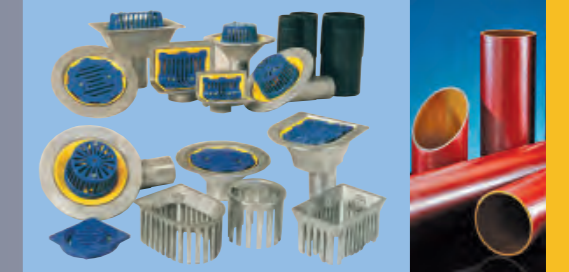

## Introduction

Alumasc's well established range of Harmer products provides a unique single source for innovative market-leading solutions across the whole spectrum of rainwater handling and building drainage.

The extensive range of Harmer outlets includes Roof, Floor and Shower drainage solutions for retail, industry and leisure complexes. Harmer outlets are compatible with most pipework systems and can be used in combination with the Harmer SML pipe system to provide a robust drainage solution that will continue to perform for the life of the building.

## Harmer Roof Outlets

Harmer Roof Outlets, in Aluminium, Cast Iron or Insulated polyurethane, provide comprehensive and innovative drainage solutions for all types of flat roof, including car parks, and also for low pitch industrial roofing.

The range is primarily suited to new building applications, but also includes a selection of refurbishment outlets. Harmer Roof Outlets can be connected to Harmer SML using the standard range of couplings.

The Aluminium range offers the AV high performance advanced flow range for flat roof applications. The Detail range includes outlets for applications such as balconies, gulleys and car parks, and two way outlets for use where the roof surface abuts a wall or parapet.

The cast Iron range features medium sump and large sump bodies with varying flow rate capacity to discharge requirements and building design. It's also complemented with two way parapet outlets and downspouts and an extensive range of loadbearing grates. (See pages 51-57 for details)



(See pages 51-57)

## Harmer Floor Drains

Drain bodies in powder coated aluminium, together with elegant grates, combine to create an unbeatable range of floor drains to suit virtually any interior drainage application and all types of flooring. Harmer Floor Drains are available either trapped or untrapped, with vertical or horizontal spigot connection, and with or without side inlets for connection from sink, bath, shower wastes, etc.

The extensive range of grates includes round and square configurations available in high quality stainless steel or nickel bronze. The Harmer Floor Drain offers great flexibility of choice, with a standard range of interchangeable components that are fast and straightforward to assemble and install. Harmer Floor Drains can be connected to Harmer SML using the standard range of couplings.

For suspended concrete floor applications Alumasc have developed a straightforward Pipe Adaptor which connects a grate assembly directly on to Harmer SML. (See pages 58-61 for details)



(See pages 58-61)

## Harmer Shower Drains

Compact size and high flow performance ensure that the Harmer Shower Drain is ideally suited to both refurbishment and new build projects. Available in either Aluminium or ABS antimicrobial trapped drain bodies. Enhanced design features also bring many benefits including corrosion resistance, durability, and attractive finishes that are tough and hygienic.

The wide choice of caps and grates available in stainless steel, nickel bronze, chromium plate and polyester power coated aluminium, will complement and enhance any shower or wet room design.

The Harmer Shower Drain is highly versatile; the drain bodies have a nominal 56mm diameter spigot and can be connected to most types of pipework including Harmer SML. The cap, clamp and trap have been designed to optimise efficient flow performance for self-cleaning and reduced maintenance. (See pages 62-68 for details)



(See pages 62-68)

## Vertical Spigot Outlets (Anti-Vortex Range)

Pipe Dia (mm)	a	b	c	d	Product Code
50	292	98	98	60	AV200
75	292	88	108	83	AV300
100	380	122	122	110	AV400
150	380	98	145	160	AV600

## Vertical Screw Outlets (Anti-Vortex Range)

Pipe Dia (mm)	a	b	c	Product Code
50	292	86	35	AV200T
75	292	76	45	AV300T
100	380	95	38	AV400T
150	380	76	38	AV600T

## 45° Spigot Outlets (Detail Range)

Pipe Dia (mm)	a	b	c	d	Product Code
50	305	229	175	62	245
75	305	235	175	87	345
100	372	273	191	114	445

## 45° Screw Outlets (Detail Range)

Pipe Dia (mm)	a	b	c	Product Code
50	305	159	109	245T
75	305	159	109	345T
100	372	186	113	445T

## 90° Spigot Outlets (Detail Range)

Pipe Dia (mm)	a	b	c	d	Product Code
50	305	124	232	62	290
75	329	121	267	83	390
100	405	142	285	110	490

# Harmer Aluminium Roof Outlets

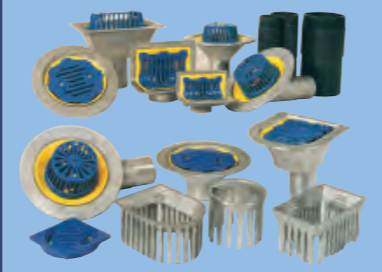

# Installation : Aluminium Roof Outlets



## 90° Screw Outlets (Detail Range)

Pipe Dia (mm)	a	b	c	Product Code
50	305	127	140	290T
75	305	127	140	390T
100	356	172	152	490T
150	356	225	152	690T

## Two-Way Outlet (Detail Range)

Pipe Dia (mm)	a	b	c	d	Product Code
50	125	140	130	190	2TW-M
50	204	214	191	255	2TW
75	204	214	191	255	3TW
100	204	214	191	255	4TW
150	280	265	250	316	6TW

## Balcony Outlets (Detail Range)

Pipe Dia (mm)	a	b	c	d	e	Product Code
50	270	110	125	242	60	2BO
75	270	110	125	242	83	3BO
100	270	110	125	242	110	4BO

## Car Park Outlets (Detail Range)

Pipe Dia (mm)	a	b	c	d	Product Code
100	380	305	95	38	400T/CP
100	380	305	76	38	600T/CP
150	—	305	95	38	400T/DD
150	—	305	76	38	600T/DD

Code suffix CP indicates flanged outlet. Code suffix DD indicates flangeless outlet.

## Screw Thread Adaptors (Accessory Range)

a	b	c	Product Code
56	150	400	2ADP
83	150	400	3ADP
110	150	400	4ADP
160	150	400	6ADP

## Typical Application Details

Please refer to Harmer Roof Outlets technical literature for detailed information.

### Harmer AV Vertical Spigot Outlet in warm roof

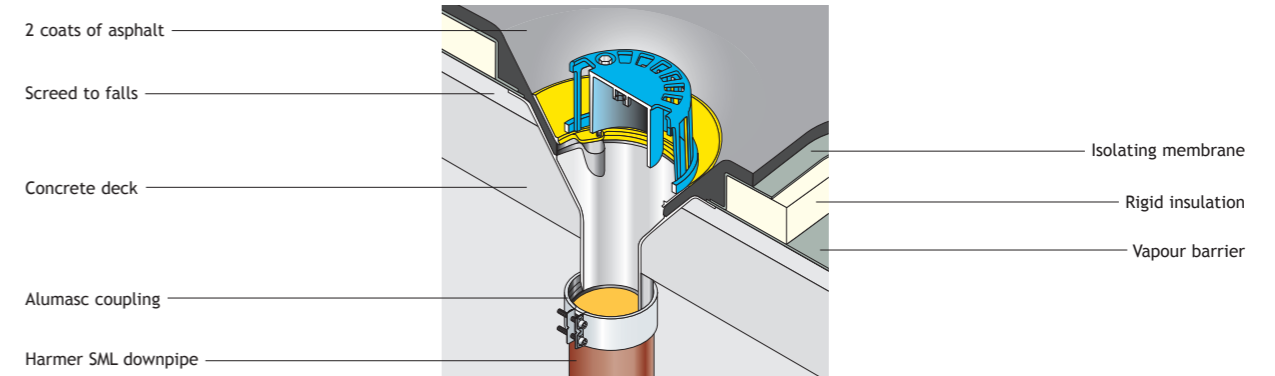

### Harmer AV Vertical Spigot Outlet with extension piece in inverted roof

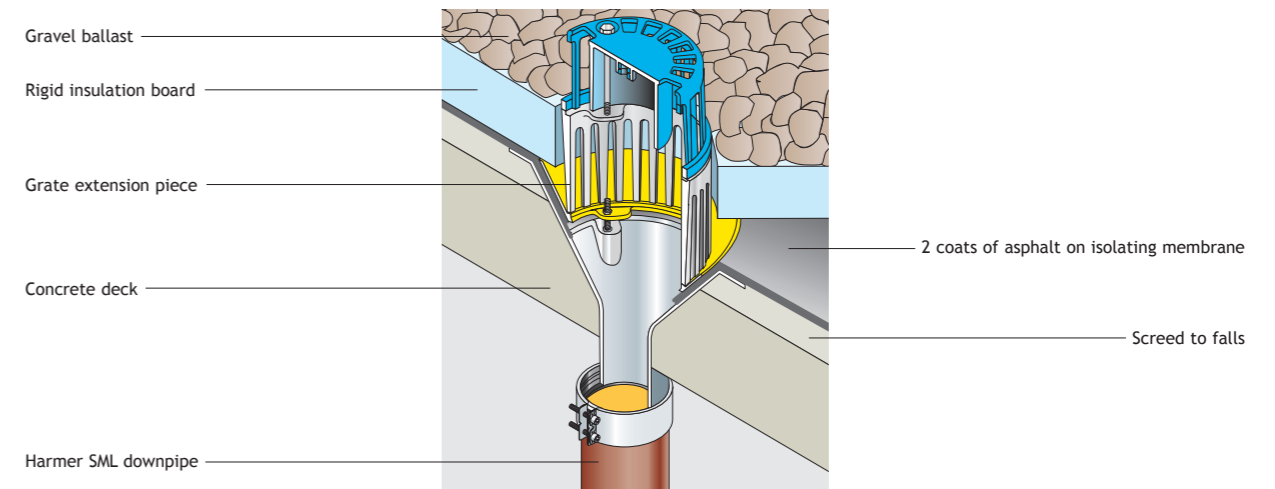

### Harmer Detail Two-Way Outlet installed for horizontal take-off from balcony

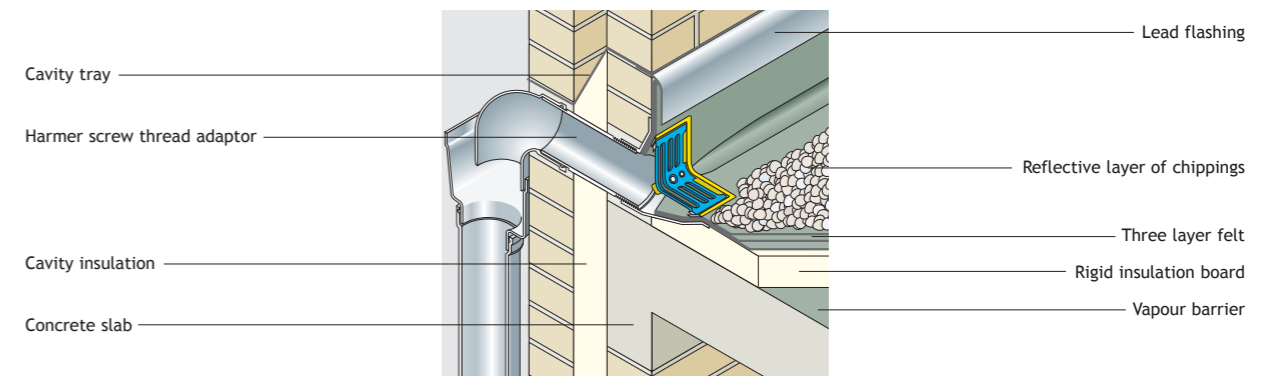

# Harmer Cast Iron Roof Outlets - Medium Sump

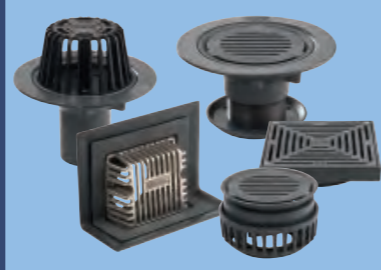

# Harmer Cast Iron Roof Outlets - Large Sump & Two-Way



## Medium Sump - Vertical Spigot Outlet - Domical Grate

Outlet Size (mm nominal)	a (mm)	b (mm)	Flow Rate <sup>1</sup> (l/s)	Weight (kg)	Product Code
50*	220	60	1.69	7.2	C200
75*	220	83	4.97	7.8	C300
100	190	110	4.97	6.7	C400

\*50 and 75mm spigot outlets are supplied with reducer pieces for assembly on site.

## Large Sump - Vertical Spigot Outlet - Domical Grate

Outlet Size (mm nominal)	a (mm)	b (BSP)	Flow Rate <sup>1</sup> (l/s)	Load Rating	Weight (kg)	Product Code
100	154	4"	8.56	n/a	14.3	C400LT
150	154	6"	10.35	n/a	12.6	C600LT

## Medium Sump - Vertical Threaded Outlet - Domical Grate

Outlet Size (mm nominal)	a (mm)	b (BSP)	Flow Rate <sup>1</sup> (l/s)	Weight (kg)	Product Code
50*	112	2"	1.69	7.6	C200T
75*	112	3"	4.97	6.8	C300T
100	100	4"	4.97	5.5	C400T

\*50 and 75mm threaded outlets are supplied with reducer pieces for assembly on site.

## Large Sump - Double Flange Variable Height Bodies - Round Flat Grate

Flat Grate Material	Flow Rate <sup>1</sup> (l/s)	Load Rating (tonne)	Weight (kg)	Suffix
Sherardized Ductile Iron	11.52*	1.5	12.2	/DF

\*For 100mm outlet size, maximum pipe capacity to BS EN 12056 applies.

Shown with vertical outlet C600LT

## Medium Sump - Horizontal Threaded Outlet - Domical Grate

Outlet Size (mm nominal)	a (mm)	b (BSP)	Flow Rate <sup>1</sup> (l/s)	Weight (kg)	Product Code
50*	105	2"	1.69	9.0	C290T
75*	105	3"	4.97	8.2	C390T
100	90	4"	4.97	7.0	C490T

\*50 and 75mm threaded outlets are supplied with reducer pieces for assembly on site.

## Two-Way Outlet - Rectangular Grate

Outlet Size (mm)	Grate Material	a (mm)	b (BSP)	Flow Rate <sup>1</sup> (l/s)		Load Rating (tonne)	Weight (kg)	Product Code
				vertical	horizontal			
50	Cast iron	38	2"	1.4	0.7	0.3	5.9	CTW2/RC
50	Nickel bronze	38	2"	1.4	0.7	0.3	6.1	CTW2/RN
50	Aluminium	38	2"	1.4	0.7	0.3	5.2	CTW2/RA
75	Cast iron	52	3"	2.6	0.8	0.3	5.8	CTW3/RC
75	Nickel bronze	52	3"	2.6	0.8	0.3	6.0	CTW3/RN
75	Aluminium	52	3"	2.6	0.8	0.3	5.1	CTW3/RA
100	Cast iron	65	4"	2.6	0.8	0.3	5.7	CTW4/RC
100	Nickel bronze	65	4"	2.6	0.8	0.3	5.8	CTW4/RN
100	Aluminium	65	4"	2.6	0.8	0.3	4.9	CTW4/RA

## Medium Sump - Double Flange Variable Height Bodies - Domical Grate

Domical Grate Material	Flow Rate <sup>1</sup> (l/s)	Load Rating (tonne)	Weight (kg)	Suffix
Polypropylene	4.97*	n/a	6.4	/D

\*For 50 and 75mm outlets maximum pipe capacity to BS EN 12056 applies.

Shown with vertical outlet C400T

## Two-Way Outlet - Flat Grate

Outlet Size (mm)	Grate Material	a (mm)	b (BSP)	Flow Rate <sup>1</sup> (l/s)		Load Rating (tonne)	Weight (kg)	Product Code
				vertical	horizontal			
50	Cast iron	38	2"	1.4	0.7	0.3	5.8	CTW2/FC
75	Cast iron	52	3"	2.6	0.8	0.3	5.7	CTW2/FC
100	Cast iron	65	4"	2.6	0.8	0.3	5.5	CTW2/FC

## Medium Sump - Double Flange Variable Height Bodies - Flat Grate

Flat Grate Material	Flow Rate <sup>1</sup> (l/s)	Load Rating (tonne)	Weight (kg)	Suffix
Sherardized Ductile Iron	6.30*	1.5	7.7	/DF

\*For 50 and 75mm outlets maximum pipe capacity to BS EN 12056 applies.

Shown with horizontal outlet C490T

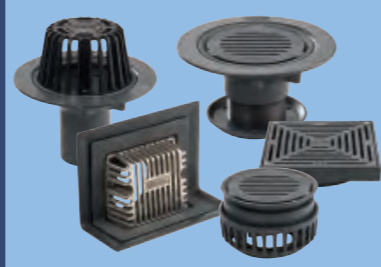

# Cast Iron Grates, Extension Pieces & Threaded Spigot Adaptors



# Cast Iron Roof Outlets - Application Details

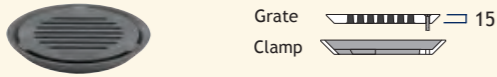

## Round Flat Grate

	Grate	 15	<b>Circular Grate Material</b>	<b>Flow Rate<sup>1</sup> (l/s)</b>	<b>Load Rating (tonne)</b>	<b>Weight (kg)</b>	<b>Suffix</b>
	Clamp			Sherardized Ductile Iron	6.30*	1.5	1.3
*For 50 and 75mm outlets maximum pipe capacity to BS EN 12056 applies.							

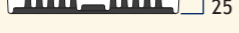
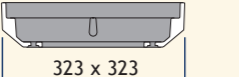

## Square Flat Grate

	Grate	 25	<b>Square Grate Material</b>	<b>Flow Rate<sup>1</sup> (l/s)</b>	<b>Load Rating (tonne)</b>	<b>Weight (kg)</b>	<b>Suffix</b>
	Clamp			Sherardized Ductile Iron	14.56*	12.5	10.5
*For 100mm outlet size, maximum pipe capacity to BS EN 12056 applies.							

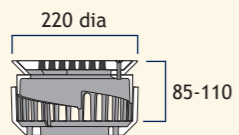
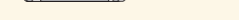

## Adjustable Round Flat Grate with Extension Piece

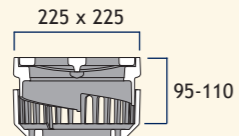
	Flat Grate	 220 dia 85-110	<b>Circular Grate Material</b>	<b>Flow Rate<sup>1</sup> (l/s)</b>	<b>Load Rating (tonne)</b>	<b>Weight (kg)</b>	<b>Suffix</b>
	Adjustable Grate Extension Piece			Sherardized Ductile Iron	6.30*	1.5	5.5
*For 50 and 75mm outlets maximum pipe capacity to BS EN 12056 applies.							

## Adjustable Square Flat Grate with Extension Piece

	Square Flat Grate - Ductile Iron	 225 x 225 95-110	<b>Square Grate Material</b>	<b>Flow Rate<sup>1</sup> (l/s)</b>	<b>Load Rating (tonne)</b>	<b>Weight (kg)</b>	<b>Suffix</b>
	Adjustable Grate Extension Piece			Sherardized Ductile Iron	6.30*	12.5	9.7
*For 50 and 75mm outlets maximum pipe capacity to BS EN 12056 applies.							

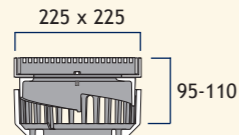
## Adjustable Square Flat Grate - Stainless Steel with Extension Piece

	Square Flat Grate - Stainless Steel	 225 x 225 95-110	<b>Square Grate Material</b>	<b>Flow Rate<sup>1</sup> (l/s)</b>	<b>Load Rating (tonne)</b>	<b>Weight (kg)</b>	<b>Suffix</b>
	Adjustable Grate Extension Piece			Stainless Steel (5mm aperture)	6.30*	12.5	7.8
*For 50 and 75mm outlets maximum pipe capacity to BS EN 12056 applies.							

## Threaded Spigot Adaptors

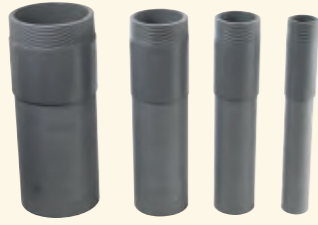
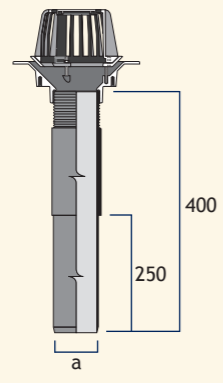
 <p>Threaded Spigot Adaptors 2ADP, 3ADP, 4ADP and 6ADP Longer lengths are available on request</p>	 400 250 a	<b>Nominal bore (mm)</b>	<b>a (mm)</b>	<b>Weight (kg)</b>	<b>Product Code</b>
		50	60	0.4	2ADP
		75	83	0.6	3ADP
		100	110	1.2	4ADP
		150	160	2.0	6ADP

## Typical Application Details

Please refer to Harmer Roof Outlets technical literature for detailed information.

### Harmer Medium Sump Vertical Spigot Double Flanged Outlet in Warm Roof Metal Deck Construction

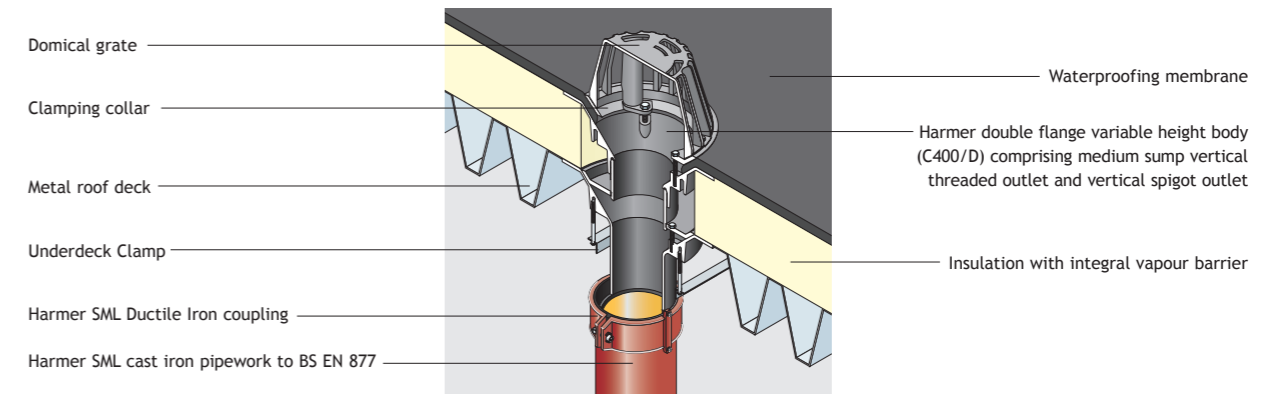

### Harmer Medium Sump Vertical Threaded Outlet with Square Grate in Inverted Roof Concrete Deck Construction

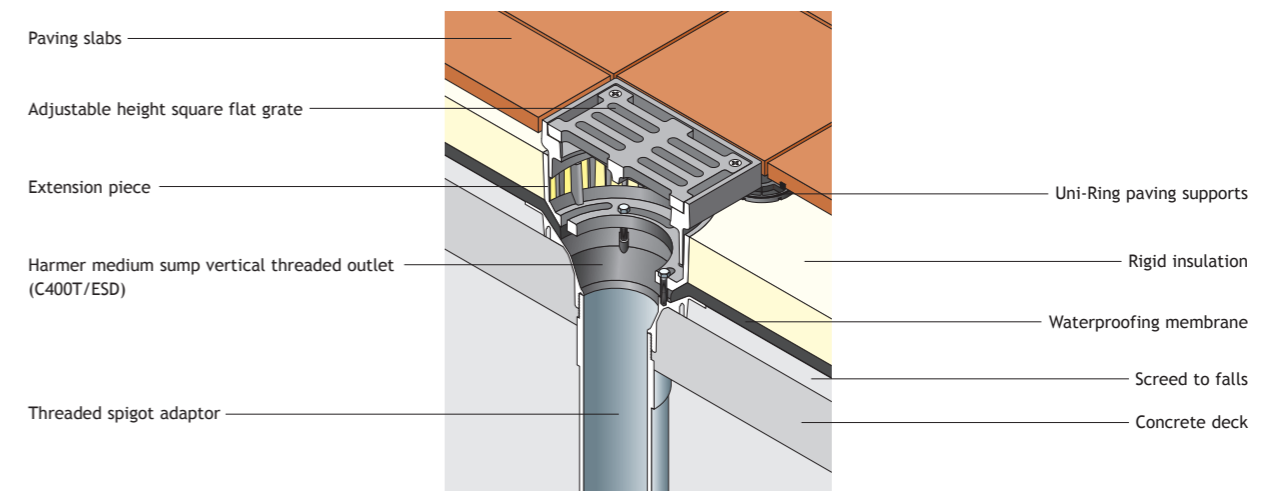

### Harmer Two-Way Outlet in Warm Roof Concrete Deck Construction

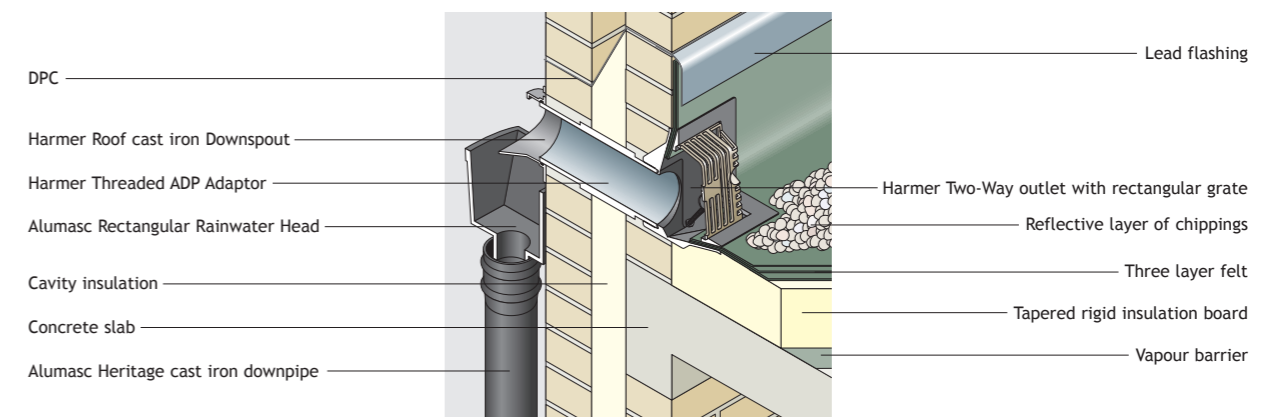

# Harmer Floor Drains



# Harmer Floor Drains



## Grates and Bezels

A range of Grates and Bezels is available to suit different floor types and aesthetic requirements. Grates and Bezels are available in stainless steel or nickel bronze. Solid plate grates are also available on request.

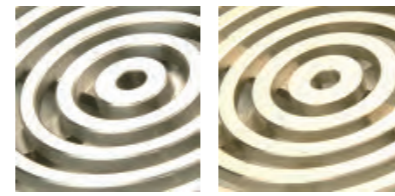

Machined stainless steel Machined nickel bronze

## Trap Assembly

When a trapped drain is required, the Grate and Bezel are supplied inclusive of the Trap. The Trap consists of a demountable funnel and cap for ease of cleaning.



Trap assembly  
(See page 60 for in-situ cross section)

## Grate and Bezel Assembly – 150mm Circular Grate

Grate and Bezel Assembly	a	b	Trap	Product Code
Machined Stainless Steel - without trap	150	140	✗	BC150MS
Machined Stainless Steel - with trap	150	140	✓	BC150MS/T
Machined Nickel Bronze - without trap	150	140	✗	BC150MN
Machined Nickel Bronze - with trap	150	140	✓	BC150MN/T

## Grate and Bezel Assembly – 150mm Square Grate

Grate and Bezel Assembly	a	b	Trap	Product Code
Machined Stainless Steel - without trap	150	140	✗	BS150MS
Machined Stainless Steel - with trap	150	140	✓	BS150MS/T
Machined Nickel Bronze - without trap	150	140	✗	BS150MN
Machined Nickel Bronze - with trap	150	140	✓	BS150MN/T

## Grate and Bezel Assembly – 200mm Square Grate

Grate and Bezel Assembly	a	b	Trap	Product Code
Machined Stainless Steel - without trap	200	140	✗	BS200MS
Machined Stainless Steel - with trap	200	140	✓	BS200MS/T
Machined Nickel Bronze - without trap	200	140	✗	BS200MN
Machined Nickel Bronze - with trap	200	140	✓	BS200MN/T

## Grate and Bezel Assembly – 200mm Vinyl Sheet Grate

Grate and Bezel Assembly	a	b	Trap	Product Code
Machined Stainless Steel - without trap	200	140	✗	BCF200MS
Machined Stainless Steel - with trap	200	140	✓	BCF200MS/T
Machined Nickel Bronze - without trap	200	140	✗	BCF200MN
Machined Nickel Bronze - with trap	200	140	✓	BCF200MN/T

## Drain Bodies

The Harmer Floor Drain Body is available with a vertical or horizontal spigot connection. Versions with inlets for connection from sink, bath, shower wastes, etc, are an option. All four drain body types will accept any of the grate assembly options, both untrapped and trapped.



Floor drain assemblies

## Fully Adjustable Drain Assembly

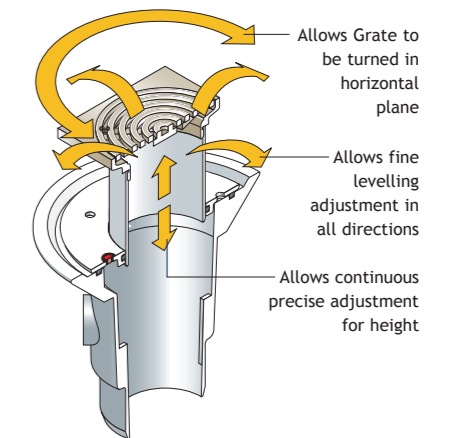

## Vertical Drain Body – Without Inlets

	a	b	c	d	Product Code
	260	110	230	48	BVS100

## Vertical Drain Body – With Inlets

	a	b	c	d	Product Code
	260	110	230	48	BVS100/A

## Horizontal Drain Body – Without Inlets

	a	b	c	d	e	Product Code
	260	110	215	48	135	BHS100

## Horizontal Drain Body – With Inlets

	a	b	c	d	e	Product Code
	260	110	215	48	135	BHS100/A

For further information on Floor Drain refer to Harmer Floor Drain technical literature



## Introduction

Harmer Floor Drains are fast and efficient to install with a standard range of interchangeable components that are straightforward to assemble. The illustrations below show a typical vertical and horizontal installation in a ground floor application. For further information on installation refer to Harmer Floor Drain technical literature or contact Alumasc Technical Helpline on 01744 648400.

## Vertical Drain

Harmer Floor Drain (BVS100) with BS150MN/T trapped grating assembly in insulated tiled ground floor with sheet DPM

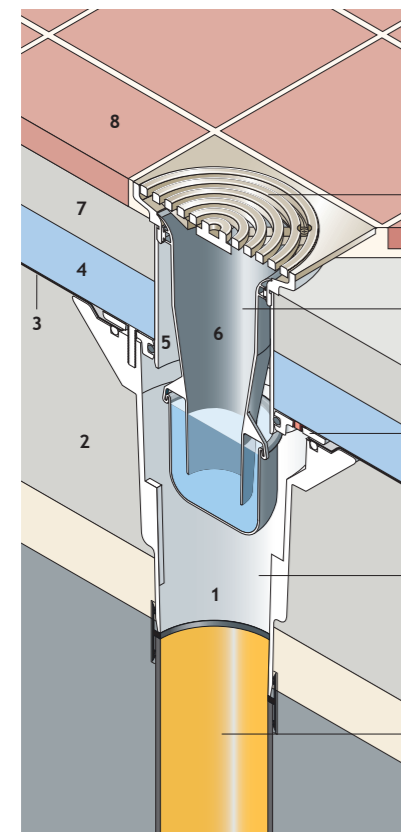

## Horizontal Drain

Harmer Floor Drain (BHS100/A) with BCF200MN/T trapped grating assembly in insulated vinyl covered ground floor with sheet DPM

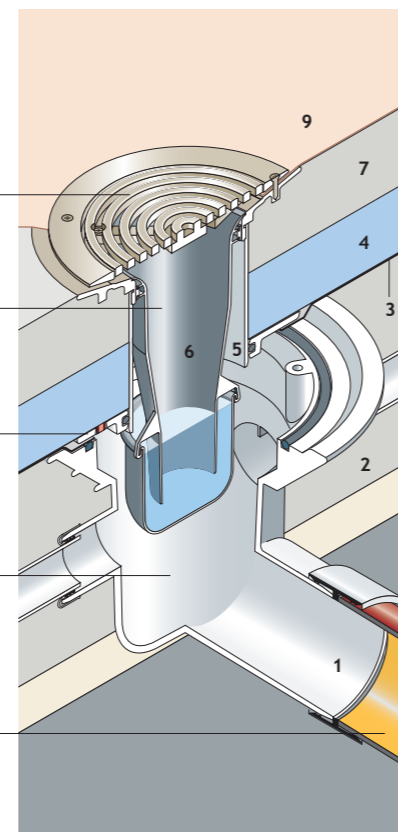

## Sitework

1. Connect the floor drain body to pipework. Secure the pipework in position so that the rim of the floor drain body will be level with the finished slab.
2. Lay concrete ground slab.
3. Lay the DPM. Cut a hole in the membrane and clamp firmly to the floor drain body by bolting the DPM Clamp Ring in position.

### Note for step 3

- The DPM Clamp Ring has a red Weep Bung to relieve the build-up of vapour pressure.
- For tiled floor finish applications, the Weep Bung should be removed.
  - For sheet vinyl floor finish applications, the Weep Bung should be left in.

4. Lay the insulation.
5. Remove the Dirt Cover and push the sliding Throat of the Grate and Bezel Assembly into the DPM Clamp Ring. Adjust for height by sliding up or down against the Throat Seal so that height of Grate above the DPM is equal to the minimum screed thickness.
6. Connect the Funnel, Cup and Funnel Seal to form the Trap Assembly. Push the assembly into the Throat. Connect Grate to Bezel.

7. Lay screed to falls.
8. Lay floor tiles and make any required further fine adjustment to Grate prior to grouting.
9. Lay the flexible sheet flooring and screw the Clamp Collar into position to secure the sheet flooring firmly against the Bezel.

## Harmer Floor Pipe Adaptors

Harmer Floor Pipe Adaptors are the quick and efficient way to incorporate a Grate and trapped pipe connection within a suspended floor.

Waterproofing is achieved in conjunction with a vinyl floor covering bonded and clamped into the appropriate Harmer Grate assembly (BCF200).

Harmer Pipe Adaptors are manufactured in SML lightweight cast iron (which is considered non-combustible in current Building Regulations), and provides complete continuity of material for onward pipe connection.

Harmer Pipe Adaptors are 400mm in length but can be made longer if required.

## Harmer SML Pipe Adaptor shown with BCF200MN grate and bezel assembly

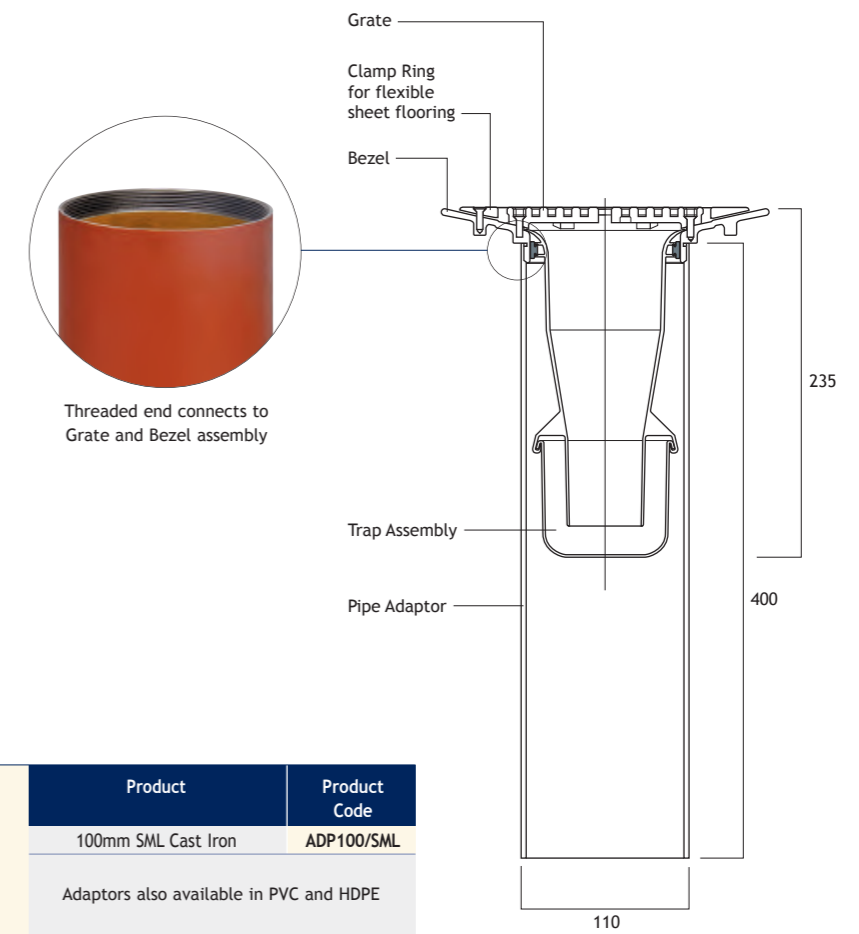

## Pipe Adaptor

Product	Product Code
100mm SML Cast Iron	ADP100/SML
Adaptors also available in PVC and HDPE	

## Typical Application Detail

### Harmer SML ADP100/SML cast iron adaptor with Harmer BCF200MN/T 200mm vinyl sheet grate assembly

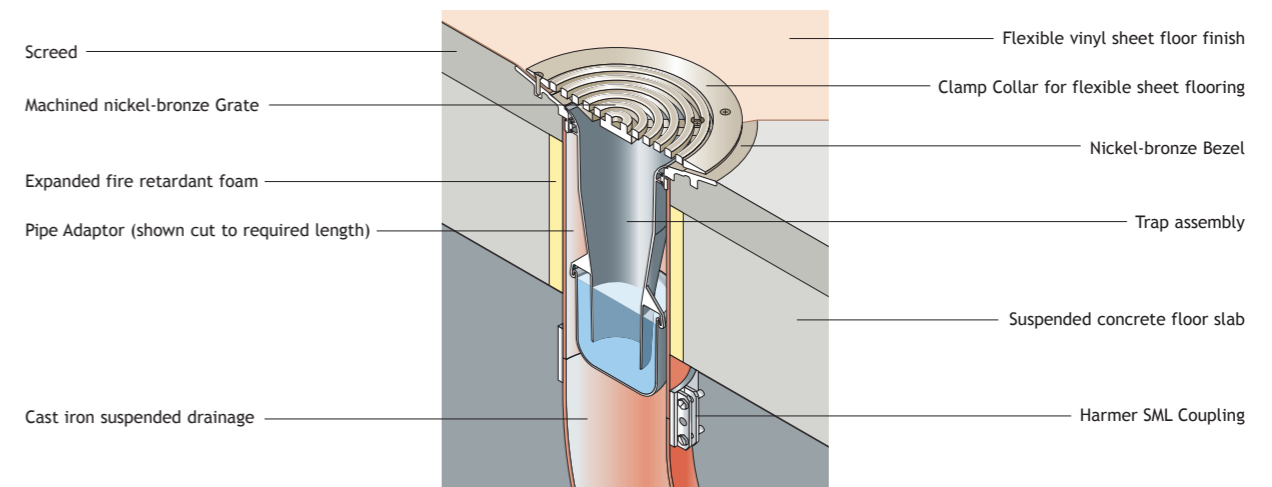

# Harmer Shower Drains



# Harmer Shower Drains



## Vertical Outlet Combinations for Flexible Sheet Flooring

Note: Add suffix /LC to product codes if anti-tamper security screws are required

Note: Nickel bronze is a copper-based alloy and may tarnish with time

### White PPC Aluminium Clamp and Pebble Cap



Product Code	Flow Rate	Load Class	Weight
AVS/WH	1.3 l/s	K3	1.1 kg

Note: Also available in a choice of colours on request. Surcharges may apply.

### Chrome Plated Aluminium Clamp and Plain Cap



Product Code	Flow Rate	Load Class	Weight
AVS/CH	1.3 l/s	K3	1.1 kg

### Stainless Steel Clamp and Plain Cap



Product Code	Flow Rate	Load Class	Weight
AVS/CS	1.3 l/s	K3	1.7 kg

### Nickel Bronze Clamp and Plain Cap



Product Code	Flow Rate	Load Class	Weight
AVS/CN	1.3 l/s	K3	1.7 kg

### Stainless Steel Clamp and Star Grate



Product Code	Flow Rate	Load Class	Weight
AVS/SS	0.8 l/s	K3	1.8 kg

### Nickel Bronze Clamp and Star Grate



Product Code	Flow Rate	Load Class	Weight
AVS/SN	0.8 l/s	K3	1.8 kg

### Stainless Steel Clamp and Concentric Ring Grate



Product Code	Flow Rate	Load Class	Weight
AVS/RS	0.8 l/s	K3	1.6 kg

### Nickel Bronze Clamp and Concentric Ring Grate



Product Code	Flow Rate	Load Class	Weight
AVS/RN	0.8 l/s	K3	1.6 kg

## Vertical Outlet Combinations for Tiled Flooring

Note: Add suffix /LC to product codes if anti-tamper security screws are required

Note: Nickel bronze is a copper-based alloy and may tarnish with time

### White PPC Aluminium Tile Frame and Pebble Cap



Product Code	Size	Flow Rate	Load Class	Weight
AVS/WH/T15	150x150mm	1.3 l/s	K3	1.3 kg
AVS/WH/T20	200x200mm	1.3 l/s	K3	1.5 kg

Note: Also available in a choice of colours on request. Surcharges may apply.

### Chrome Plated Aluminium Tile Frame and Plain Cap



Product Code	Size	Flow Rate	Load Class	Weight
AVS/CH/T15	150x150mm	1.3 l/s	K3	1.3 kg
AVS/CH/T20	200x200mm	1.3 l/s	K3	1.5 kg

### Stainless Steel Tile Frame and Plain Cap



Product Code	Size	Flow Rate	Load Class	Weight
AVS/CS/T15	150x150mm	1.3 l/s	K3	2.0 kg
AVS/CS/T20	200x200mm	1.3 l/s	K3	2.7 kg

### Nickel Bronze Tile Frame and Plain Cap



Product Code	Size	Flow Rate	Load Class	Weight
AVS/CN/T15	150x150mm	1.3 l/s	K3	2.0 kg
AVS/CN/T20	200x200mm	1.3 l/s	K3	2.7 kg

### Stainless Steel Tile Frame and Star Grate



Product Code	Size	Flow Rate	Load Class	Weight
AVS/SS/T15	150x150mm	0.8 l/s	K3	2.1 kg
AVS/SS/T20	200x200mm	0.8 l/s	K3	2.8 kg

### Nickel Bronze Tile Frame and Star Grate

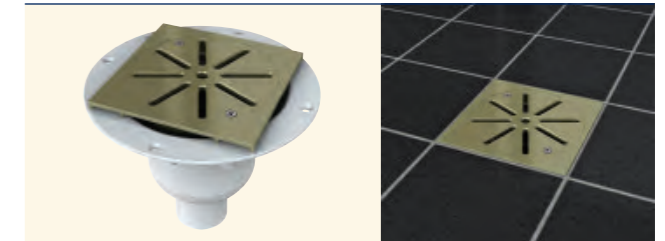

Product Code	Size	Flow Rate	Load Class	Weight
AVS/SN/T15	150x150mm	0.8 l/s	K3	2.1 kg
AVS/SN/T20	200x200mm	0.8 l/s	K3	2.8 kg

### Stainless Steel Tile Frame and Concentric Ring Grate



Product Code	Size	Flow Rate	Load Class	Weight
AVS/RS/T15	150x150mm	0.8 l/s	K3	2.0 kg
AVS/RS/T20	200x200mm	0.8 l/s	K3	2.6 kg

### Nickel Bronze Tile Frame and Concentric Ring Grate



Product Code	Size	Flow Rate	Load Class	Weight
AVS/RN/T15	150x150mm	0.8 l/s	K3	2.0 kg
AVS/RN/T20	200x200mm	0.8 l/s	K3	2.6 kg

# Harmer Shower Drains



# Harmer Shower Drains

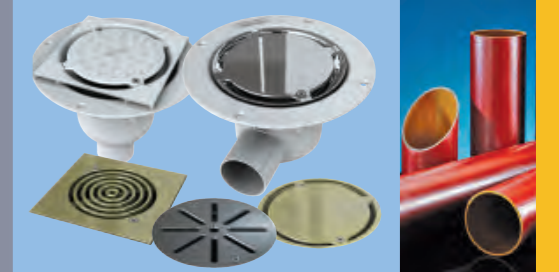

## Horizontal Outlet Combinations for Flexible Sheet Flooring

Note: Add suffix /LC to product codes if anti-tamper security screws are required

Note: Nickel bronze is a copper-based alloy and may tarnish with time

### White PPC Aluminium Clamp and Pebble Cap



Product Code	Flow Rate	Load Class	Weight
AHS/WH	0.8 l/s	K3	1.1 kg

Note: Also available in a choice of colours on request. Surcharges may apply.

### Chrome Plated Aluminium Clamp and Plain Cap



Product Code	Flow Rate	Load Class	Weight
AHS/CH	0.8 l/s	K3	1.1 kg

### Stainless Steel Clamp and Plain Cap



Product Code	Flow Rate	Load Class	Weight
AHS/CS	0.8 l/s	K3	1.7 kg

### Nickel Bronze Clamp and Plain Cap



Product Code	Flow Rate	Load Class	Weight
AHS/CN	0.8 l/s	K3	1.7 kg

### Stainless Steel Clamp and Star Grate



Product Code	Flow Rate	Load Class	Weight
AHS/SS	0.8 l/s	K3	1.8 kg

### Nickel Bronze Clamp and Star Grate



Product Code	Flow Rate	Load Class	Weight
AHS/SN	0.8 l/s	K3	1.8 kg

### Stainless Steel Clamp and Concentric Ring Grate



Product Code	Flow Rate	Load Class	Weight
AHS/RS	0.8 l/s	K3	1.6 kg

### Nickel Bronze Clamp and Concentric Ring Grate



Product Code	Flow Rate	Load Class	Weight
AHS/RN	0.8 l/s	K3	1.6 kg

## Horizontal Outlet Combinations for Tiled Flooring

Note: Add suffix /LC to product codes if anti-tamper security screws are required

Note: Nickel bronze is a copper-based alloy and may tarnish with time

### White PPC Aluminium Tile Frame and Pebble Cap

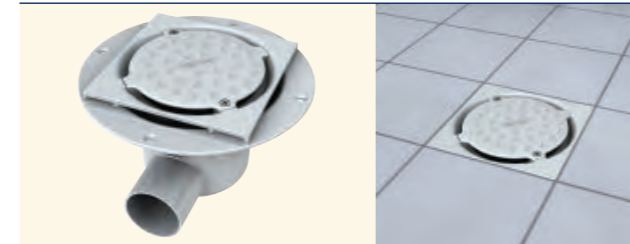

Product Code	Size	Flow Rate	Load Class	Weight
AHS/WH/T15	150x150mm	0.8 l/s	K3	1.3 kg
AHS/WH/T20	200x200mm	0.8 l/s	K3	1.5 kg

Note: Also available in a choice of colours on request. Surcharges may apply.

### Chrome Plated Aluminium Tile Frame and Plain Cap

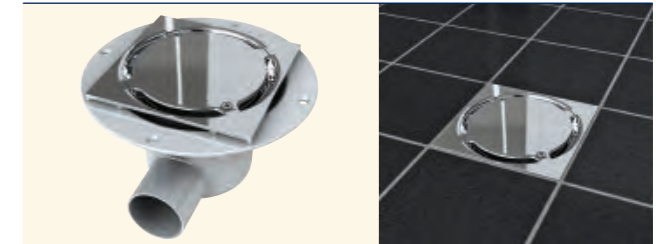

Product Code	Size	Flow Rate	Load Class	Weight
AHS/CH/T15	150x150mm	0.8 l/s	K3	1.3 kg
AHS/CH/T20	200x200mm	0.8 l/s	K3	1.5 kg

### Stainless Steel Tile Frame and Plain Cap



Product Code	Size	Flow Rate	Load Class	Weight
AHS/CS/T15	150x150mm	0.8 l/s	K3	2.0 kg
AHS/CS/T20	200x200mm	0.8 l/s	K3	2.7 kg

### Nickel Bronze Tile Frame and Plain Cap

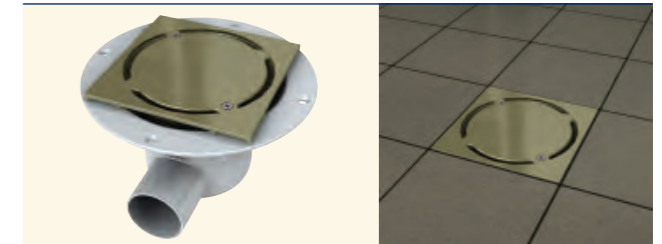

Product Code	Size	Flow Rate	Load Class	Weight
AHS/CN/T15	150x150mm	0.8 l/s	K3	2.0 kg
AHS/CN/T20	200x200mm	0.8 l/s	K3	2.7 kg

### Stainless Steel Tile Frame and Star Grate



Product Code	Size	Flow Rate	Load Class	Weight
AHS/SS/T15	150x150mm	0.8 l/s	K3	2.1 kg
AHS/SS/T20	200x200mm	0.8 l/s	K3	2.8 kg

### Nickel Bronze Tile Frame and Star Grate

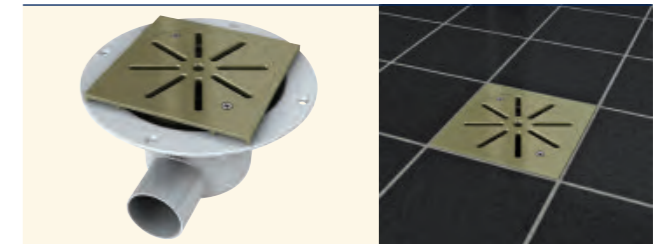

Product Code	Size	Flow Rate	Load Class	Weight
AHS/SN/T15	150x150mm	0.8 l/s	K3	2.1 kg
AHS/SN/T20	200x200mm	0.8 l/s	K3	2.8 kg

### Stainless Steel Tile Frame and Concentric Ring Grate



Product Code	Size	Flow Rate	Load Class	Weight
AHS/RS/T15	150x150mm	0.8 l/s	K3	2.0 kg
AHS/RS/T20	200x200mm	0.8 l/s	K3	2.6 kg

### Nickel Bronze Tile Frame and Concentric Ring Grate



Product Code	Size	Flow Rate	Load Class	Weight
AHS/RN/T15	150x150mm	0.8 l/s	K3	2.0 kg
AHS/RN/T20	200x200mm	0.8 l/s	K3	2.6 kg

# Harmer Shower Drains



# Harmer Shower Drains



## Vertical Outlet Combinations for Flexible Sheet Flooring

Note: Add suffix /LC to product codes if anti-tamper security screws are required

### White Clamp and ABS Pebble Cap



Product Code	Flow Rate	Load Class	Weight
CVS/CP	1.3 l/s	K3	0.5 kg

## Vertical Outlet Combinations for Tiled Flooring

Note: Add suffix /LC to product codes if anti-tamper security screws are required

### White Tile Frame and ABS Pebble Cap



Product Code	Size	Flow Rate	Load Class	Weight
CVS/CP/T15	150x150mm	1.3 l/s	K3	0.7 kg
CVS/CP/T20	200x200mm	1.3 l/s	K3	0.9 kg

## Horizontal Outlet Combinations for Flexible Sheet Flooring

Note: Add suffix /LC to product codes if anti-tamper security screws are required

### White Clamp and ABS Pebble Cap



Product Code	Flow Rate	Load Class	Weight
CHS/CP	0.8 l/s	K3	0.5 kg

## Horizontal Outlet Combinations for Tiled Flooring

Note: Add suffix /LC to product codes if anti-tamper security screws are required

### White Tile Frame and ABS Pebble Cap

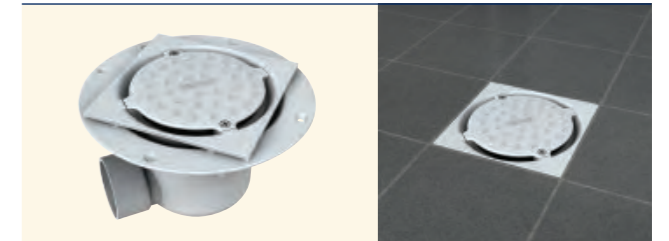

Product Code	Size	Flow Rate	Load Class	Weight
CHS/CP/T15	150x150mm	0.8 l/s	K3	0.7 kg
CHS/CP/T20	200x200mm	0.8 l/s	K3	1.0 kg

### White Clamp and ABS Quadrant Cap



Product Code	Flow Rate	Load Class	Weight
CVS/CQ	1.3 l/s	K3	0.5 kg

### White Tile Frame and ABS Quadrant Cap



Product Code	Size	Flow Rate	Load Class	Weight
CVS/CQ/T15	150x150mm	1.3 l/s	K3	0.7 kg
CVS/CQ/T20	200x200mm	1.3 l/s	K3	0.9 kg

### White Clamp and ABS Quadrant Cap



Product Code	Flow Rate	Load Class	Weight
CHS/CQ	0.8 l/s	K3	0.5 kg

### White Tile Frame and ABS Quadrant Cap



Product Code	Size	Flow Rate	Load Class	Weight
CHS/CQ/T15	150x150mm	0.8 l/s	K3	0.7 kg
CHS/CQ/T20	200x200mm	0.8 l/s	K3	1.0 kg

### Chrome Plated Aluminium Clamp and Plain Cap

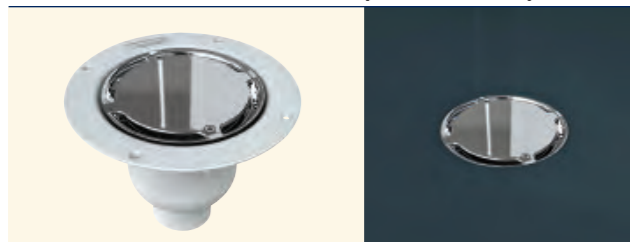

Product Code	Flow Rate	Load Class	Weight
CVS/CH	1.3 l/s	K3	0.7 kg

### Chrome Plated Aluminium Tile Frame and Plain Cap



Product Code	Size	Flow Rate	Load Class	Weight
CVS/CH/T15	150x150mm	1.3 l/s	K3	0.8 kg
CVS/CH/T20	200x200mm	1.3 l/s	K3	1.1 kg

### Chrome Plated Aluminium Clamp and Plain Cap

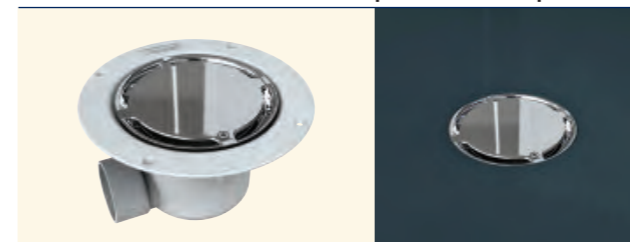

Product Code	Flow Rate	Load Class	Weight
CHS/CH	0.8 l/s	K3	0.7 kg

### Chrome Plated Aluminium Tile Frame and Plain Cap

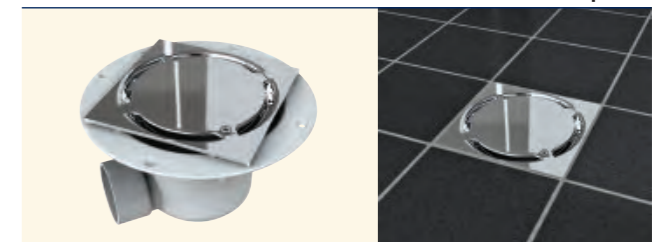

Product Code	Size	Flow Rate	Load Class	Weight
CHS/CH/T15	150x150mm	0.8 l/s	K3	0.8 kg
CHS/CH/T20	200x200mm	0.8 l/s	K3	1.1 kg



## Harmer Shower Drain with Vertical Outlet in suspended concrete floor with tiled flooring

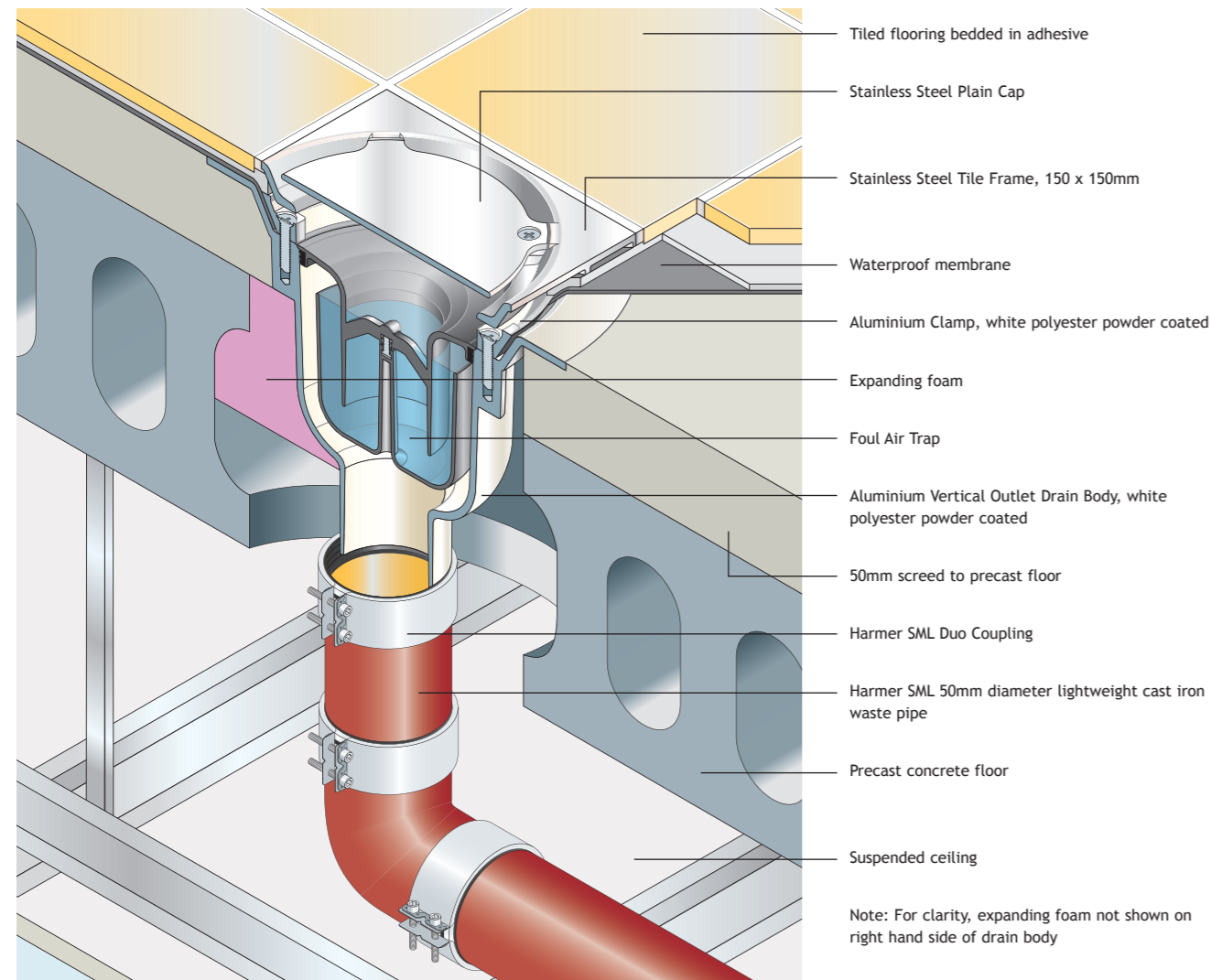

### Sitework

1. Form hole in precast concrete floor to receive Drain Body.
2. Form shutter around hole and lay main area of screed, ensuring a fall of 1:40 towards the proposed drain position.
3. Remove shutter. Place, and temporarily support, Drain Body to the correct level.
4. Within precast concrete floor depth, seal space around Drain Body with expanding foam. Keep clear of outlet spigot.
5. Remove temporary support. Lay remaining screed so that Drain Body flange is flush with top of screed.
6. Connect Drain Body to Harmer SML waste pipe using Harmer SML Duo Coupling.
7. Apply waterproof membrane to manufacturers' instructions. Dress membrane over and seal to rim of Drain Body. Trim to edge of screw pockets (optimum hole diameter is 122mm). Do not cut into protective Drain Body coating.
8. Screw Clamp firmly in position to secure waterproof membrane.
9. Bed the Tile Frame over the Drain Body to the required level, using tile adhesive.
10. Bed tiles with tile adhesive, working away from the Tile Frame.
11. Insert Foul Air Trap into Drain Body and prime.
12. Screw Plain Cap onto Tile Frame.
13. Apply flexible sealant between tile and edge of Tile Frame, then apply grout conventionally to remainder of tile joints.

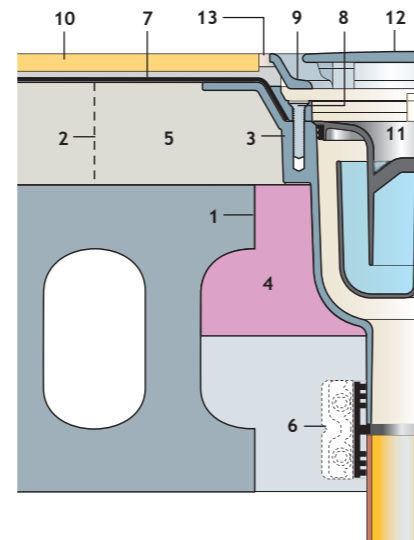

The Harmer MLK Underground Drainage System and the SML Above-Ground Drainage System are fully compatible and, used together, will provide a completely integrated soil and waste system for any building project.

## Harmer MLK Underground Drainage System

### Introduction

The Harmer MLK drainage pipe system was developed specifically for the drainage of aggressive waste water applications. The Harmer MLK system has the identical material specification of Harmer SML and encapsulates all the benefits of modern cast iron but with additional coating protection.

### Quality Standard

Harmer MLK meets the requirements of BS EN 877 and is manufactured under ISO 9001: 2000 Quality Management System (Cert. No.12 100 21864).

### Coating Specification

The properties of Harmer MLK coatings exceed the requirements of BS EN 877 by far. Please contact Alumasc Technical Service for details of chemical resistance parameters.

### Pipe Coatings

External surface – anti-corrosive metallic zinc basecoat with grey primer top layer.

- Colour: Grey
- Thickness: Metallic zinc base coat 130 g/m<sup>2</sup>  
Epoxy primer top coat 60 µm

Internal surface – two-part epoxy lining

- Colour: Ochre
- Thickness: 200-240 µm (min. 200 µm)

### Fitting Coatings

MLK fittings are internally and externally coated with grey two-part epoxy coating, dip applied to a thickness of 200 µm.

### Size range

Harmer MLK is available in size range 50-200mm diameter with a comprehensive range of fittings. Please contact Alumasc for details.

### Couplings

For below-ground connections, the Harmer Terra Coupling is recommended. This twin-screw stainless steel coupling is available in grade 304 as standard or grade 316 for hostile environments.

### Applicable Standards

- BS EN12056: 2000, Gravity drainage within buildings.
- BS EN752: Drainage Systems outside buildings.

For further details on the application of Harmer MLK, please contact Alumasc Technical Service.

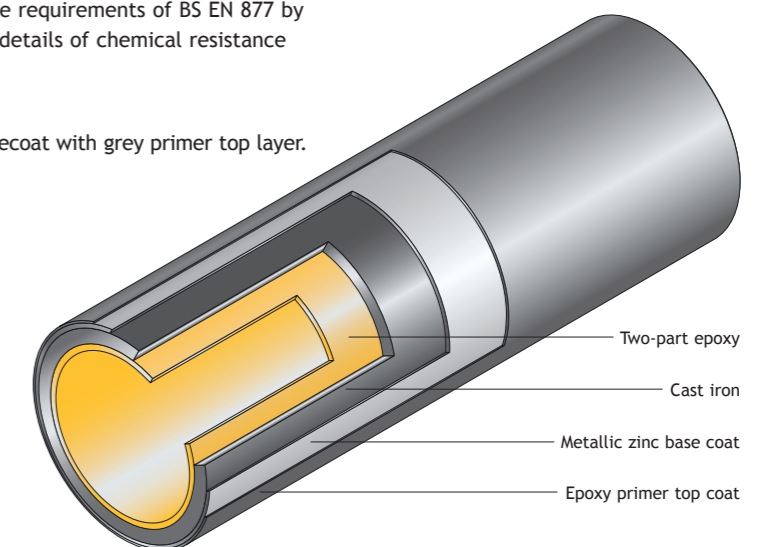

## Other Harmer Drainage Products

In addition to the SML System, and the compatible Roof Outlets, Floor Outlets, Shower Drains and MLK System, Alumasc also offers a variety of other drainage products, five of which are shown below.

### Harmer LCC

Harmer LCC is a traditional socketed cast iron pipe and fittings system manufactured to original imperial dimensions. It has been created specifically for use in building refurbishment and historic building contracts where there is a need to faithfully reproduce period detail.

An extensive range of fittings and accessories provides great flexibility in installation, while special detailing requirements can be catered for through Alumasc's fabrication and pattern making workshops.



LCC

### Harmer Kessel

Harmer Kessel is the Alumasc offer for specialist drainage. Kessel plastic drainage systems are based on modular ranges of components which can be combined in different formats to provide heavy duty drainage solutions for a wide range of applications, by the incorporation of backflow valves, automatic pumps and sludge buckets.

Harmer Kessel drains also incorporate all of the design advantages associated with Harmer Floor Outlets plus the economies of plastics in use with stainless steel.



Kessel

### Harmer Linearis

Linearis shower drainage range removes the need for a conventional shower tray and offers a choice of innovative slimline drainage channels along with more traditional shower gully products, but all with a contemporary styling that will complement any shower or wet room.

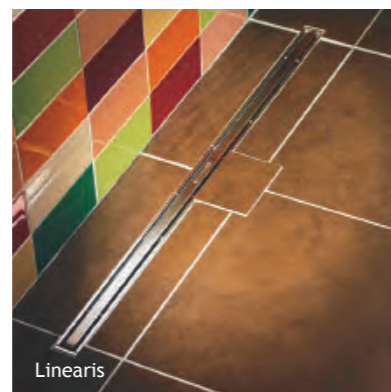

Linearis

### Harmer Modulock

Harmer Modulock is a fully engineered levelling, raised pedestal system for supporting paving slabs, timber or plywood sheet decking at varying heights from the sub-structure.

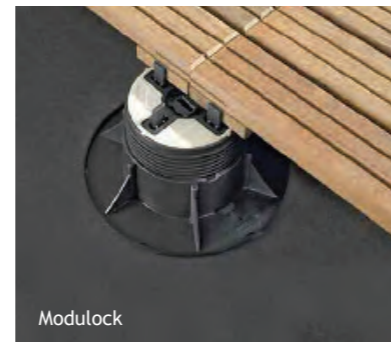

Modulock

### Modulock Channel Drain

Harmer Modulock Channel Drain is a highly versatile linear drainage system designed to provide the ideal level access drainage solution where rainwater run-off and percolation are required.

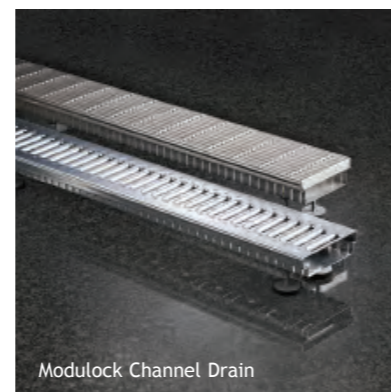

Modulock Channel Drain

## Alumasc Premium Products

Alumasc provides an unrivalled range of premium products for building exteriors and drainage, along with high levels of technical expertise and project support. Our wealth of experience combined with networks of approved installers, merchant stockists and a choice of warranty options ensures we provide appropriate product and system solutions for all types of buildings.



Alumasc is the UK's leading manufacturer of aluminium rainwater systems and offers a complete range of gutters, downpipes and fascia/soffits for both contemporary and traditional architecture.

Alumasc's cast iron rainwater system is for historic and restoration sites, with bespoke designs available to match or replace existing installations.

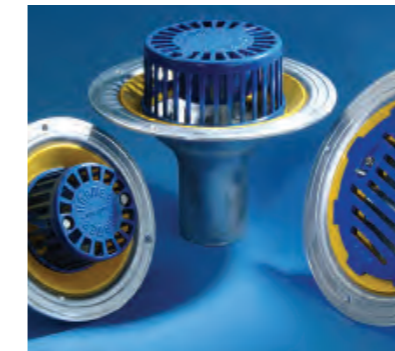

Alumasc's Harmer brand provides market leading solutions for rainwater handling and building drainage.

Aluminium roof, floor and shower drains are complemented by specialist drainage ranges in plastic. A choice of cast iron pipework systems is available for internal and rainwater drainage. Specialist rainwater management systems and paving and deck supports are also available.



Alumasc is a specialist provider of world class waterproofing and green roof systems.

The range includes Derbigum and Eurorof high performance flat roof membranes, Eurorof cold applied membranes, Firestone TPO and EPDM single ply membranes, Hydrotech structural waterproofing and ZinCo Extensive, Biodiverse, Semi-intensive and Intensive green roofs.



Alumasc is a specialist in the design and development of thermally efficient insulated render systems. Alumasc's external wall insulation systems are available with a choice of insulating material and silicone, mineral or polymer-modified decorative render finishes.

### ALUMASC

RAINWATER SYSTEMS

- Aluminium Rainwater Systems
- Aluminium Fascias, Soffits and Copings
- Cast Iron Rainwater Systems

[www.alumascrainwater.co.uk](http://www.alumascrainwater.co.uk)

### HARMER

DRAINAGE SYSTEMS

- Roof, Floor and Shower Drains
- Cast Iron Soil & Waste Systems
- Rainwater Management Systems
- Paving and Decking Supports

[www.harmerdrainage.co.uk](http://www.harmerdrainage.co.uk)

### ALUMASC

ROOFING SYSTEMS

- Flat Roof Membranes
- Single Ply Membranes
- Structural Waterproofing
- Green Roof Systems

[www.alumascwaterproofing.co.uk](http://www.alumascwaterproofing.co.uk)

### ALUMASC

INSULATED RENDERS

- External Wall Insulation
- Render Only Systems
- Brick Slips & Specialist Systems
- Decorative Coatings

[www.alumascfacades.co.uk](http://www.alumascfacades.co.uk)

# HARMER

DRAINAGE SYSTEMS

Technical Support

+44 (0) 1744 648400

Literature Hotline

+44 (0) 808 100 2008

Website

[www.harmerdrainage.co.uk](http://www.harmerdrainage.co.uk)

ALUMASC EXTERIOR BUILDING PRODUCTS LTD

White House Works, Bold Road, Sutton,

St Helens, Merseyside, WA9 4JG

United Kingdom

Telephone: +44 (0)1744 648400

Facsimile: +44 (0)1744 648401

Website: [www.harmerdrainage.co.uk](http://www.harmerdrainage.co.uk)

E-mail: [info@alumasc-exteriors.co.uk](mailto:info@alumasc-exteriors.co.uk)

A division of:



All reasonable care has been taken in the preparation of this brochure, all information, recommendations and guidance notes on the use of The Products are made without guarantee since the conditions of use are beyond the control of Alumasc Exterior Building Products Limited (The Company). The customer is responsible for ensuring that each product is fit for its intended purpose and that conditions for use are suitable. The information contained in this brochure and advice arising therefrom is free of charge and accordingly on the terms that no liability nor liability for negligence will attach to the Company or its servants in relation to any such service arising out of or in connection with this brochure. The Company pursues a policy of constant product development and information contained in this publication is therefore subject to change without notice.

0213/2K