

Beam & Block

LOADSPAN TABLES

Prestressed Beams

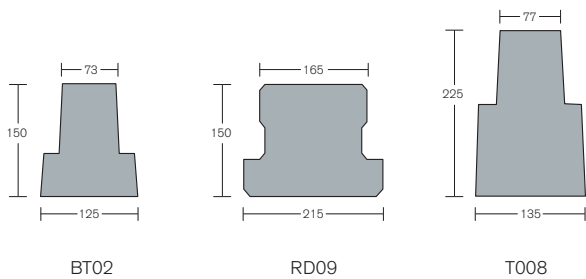

Beam details

Beam Reference	Width (mm)	Height (mm)	Weight (kN/m)	Weight (kg/m)
BT02	125	150	0.326	33.24
RD09	215	150	0.622	63.40
T008	135	225	0.576	58.74

The loadspan tables below are given as a guide only, further advice is available on request.

Load span table (150mm deep)

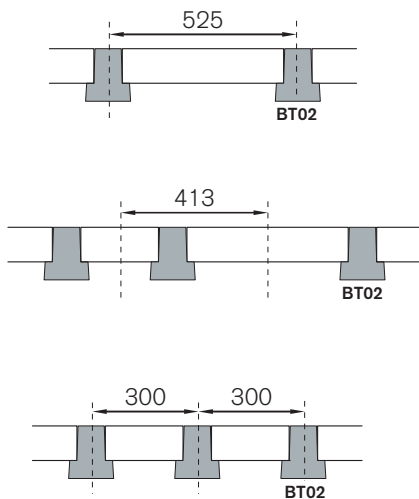

Floor Case	Floor Self Weight* kN/m ²	Finishes = 1.5 kN/m ²						Finishes = 2.0 kN/m ²					
		Superimposed Loadings in kN/m ²						Superimposed Loadings in kN/m ²					
		1.5	2.0	2.5	3.0	4.0	5.0	1.5	2.0	2.5	3.0	4.0	5.0
IJ1	1.83	Maximum Clear Span (m)						Maximum Clear Span (m)					
		4.25	4.04	3.86	3.70	3.42	3.19	4.04	3.86	3.70	3.56	3.31	3.10

IJ2	1.94	Maximum Clear Span (m)						Maximum Clear Span (m)					
		4.75	4.52	4.32	4.14	3.84	3.59	4.52	4.32	4.14	3.99	3.72	3.49

IJ3	2.18	Maximum Clear Span (m)						Maximum Clear Span (m)					
		5.40	5.20	4.98	4.79	4.46	4.17	5.20	4.98	4.79	4.62	4.32	4.06

Load span table (150mm deep)

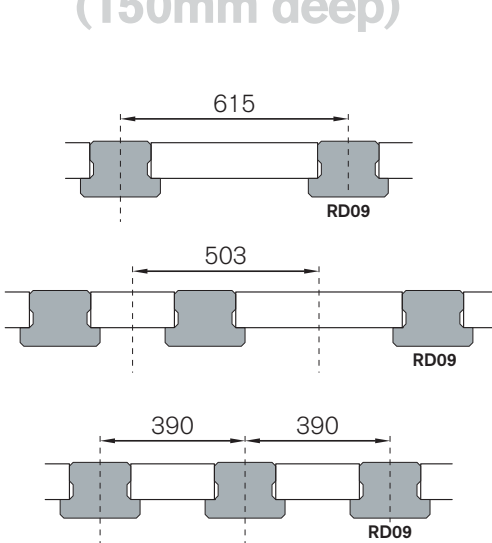

Floor Case	Floor Self Weight* kN/m ²	Finishes = 1.5 kN/m ²						Finishes = 2.0 kN/m ²					
		Superimposed Loadings in kN/m ²						Superimposed Loadings in kN/m ²					
		1.5	2.0	2.5	3.0	4.0	5.0	1.5	2.0	2.5	3.0	4.0	5.0
RDJ4	2.10	Maximum Clear Span (m)						Maximum Clear Span (m)					
		5.54	5.28	5.05	4.85	4.52	4.24	5.28	5.05	4.85	4.68	4.37	4.12

Floor Case	Floor Self Weight* kN/m ²	Maximum Clear Span (m)						Maximum Clear Span (m)					
		1.5	2.0	2.5	3.0	4.0	5.0	1.5	2.0	2.5	3.0	4.0	5.0
RDJ5	2.25	6.04	5.77	5.53	5.32	4.95	4.66	5.77	5.53	5.32	5.13	4.80	4.53

Floor Case	Floor Self Weight* kN/m ²	Maximum Clear Span (m)						Maximum Clear Span (m)					
		1.5	2.0	2.5	3.0	4.0	5.0	1.5	2.0	2.5	3.0	4.0	5.0
RDJ6	2.47	6.60	6.44	6.18	5.95	5.56	5.24	6.44	6.18	5.95	5.75	5.39	5.09

*The floor self weight includes the weight of the beams and the concrete blocks.

Load span table (225mm deep)

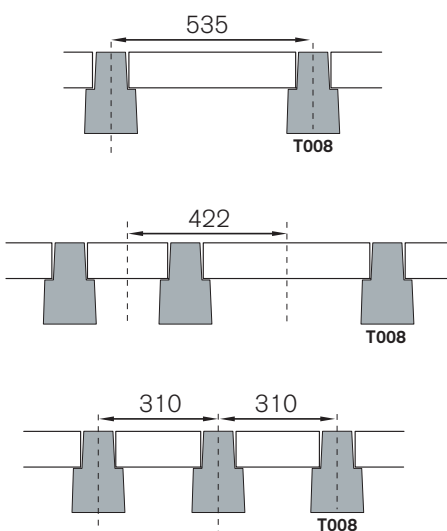

Floor Case	Floor Self Weight* kN/m ²	Finishes = 1.5 kN/m ²						Finishes = 2.9 kN/m ²					
		Superimposed Loadings in kN/m ²						Superimposed Loadings in kN/m ²					
		1.5	2.0	2.5	3.0	4.0	5.0	1.5	2.0	2.5	3.0	4.0	5.0
TJ1	2.33	Maximum Clear Span (m)						Maximum Clear Span (m)					
		6.64	6.34	6.08	5.85	5.46	5.12	6.34	6.08	5.85	5.65	5.29	4.99

Floor Case	Floor Self Weight* kN/m ²	Maximum Clear Span (m)						Maximum Clear Span (m)					
		1.5	2.0	2.5	3.0	4.0	5.0	1.5	2.0	2.5	3.0	4.0	5.0
TJ2	2.56	7.34	7.03	6.75	6.50	6.08	5.71	7.03	6.75	6.50	6.28	5.90	5.57

Floor Case	Floor Self Weight* kN/m ²	Maximum Clear Span (m)						Maximum Clear Span (m)					
		1.5	2.0	2.5	3.0	4.0	5.0	1.5	2.0	2.5	3.0	4.0	5.0
TJ3	2.98	8.00	7.99	7.69	7.43	6.97	6.58	7.99	7.69	7.52	7.19	6.77	6.42

*The floor self weight includes the weight of the beams and the concrete blocks.