

Technical Report



INVESTOR IN PEOPLE

Report Number C/08/5L/20184/R06

Date 31 October 2008

Project

**The Laboratory Determination of
Airborne Sound Transmission,
Of Various Door Sets**

Prepared for

**Hanson & Beards Ltd
Springhall Works
Springhall Grove
Halifax**

By

Allen Smalls



0444

Sound Research Laboratories Limited

Consultants in Noise & Vibration

Head Office & Laboratory: Holbrook House, Little Waldingfield
Sudbury, Suffolk CO10 0TH

Telephone (01787) 247595 Fax (01787) 248420

e-mail: srl@soundresearch.co.uk

*This report shall not be reproduced, except in full,
without written approval of the laboratory*

1.0 Summary

Tests have been done in SRL's Laboratory at Holbrook House, Sudbury, Suffolk, to determine the sound reduction index of various door sets in accordance with BS EN ISO 140-3:1995.

From these measurements the required results have been derived and are presented in both tabular and graphic form in Appendix 3.

The results are given in 1/3rd octave bands over the frequency range 50Hz to 10KHz, which is beyond that required by the test standard. Measurements outside the standard frequency range are not UKAS accredited.



.....
Allen Smalls
Laboratory Manager
Quality Manager



.....
Trevor Hickman
Executive Consultant
Deputy Technical Manager

For and on behalf of
Sound Research Laboratories Ltd

Contents

1.0 Summary

2.0 Details of Measurements

3.0 Description of Test

4.0 Results

Appendix 1: Test Procedure

Appendix 2: Measurement Uncertainty

Appendix 3: Data Sheets

Appendix 4: Test Details

Appendix 5: Drawings

2.0 Details of Measurements

2.1 Location

Sound Research Laboratories Ltd
Holbrook House
Little Waldingfield
Sudbury
Suffolk
CO10 0TH

2.2 Test Dates

29 & 30 May 2008
4 & 5 and 10 June 2008

2.3 Instrumentation and Apparatus Used

Make	Description	Type
E D I	Microphone Multiplexer Microphone Power Supply Unit	
Norwegian	Real Time Analyser	830
Electronics	Rotating Microphone Boom	231
Brüel & Kjaer	12mm Condenser Microphones	4166
	Windshields	UA0237
	Pre Amplifiers	2639, 2669C
	Microphone Calibrator	4231
	Omnipower Sound Source	4296
Larson Davis	12mm Condenser Microphone	2560
SRL	Power Amplifiers	
Celestion	Loudspeakers	100w

Douglas Curtis	Rotating Microphone Boom	
Thermo Hygro	Temperature & Humidity Probe	
TOA	Graphic Equalizer	E-1231
	Power Amplifier	DPA-800

2.4 References

BS EN ISO 140-3:1995	Laboratory measurement of airborne sound insulation of building elements
BS EN ISO 717-1:1997	Rating of sound insulation in buildings and of building elements. Airborne Sound Insulation.

2.5 Personnel Present

I Stalker	Norsound Ltd
T Palmer	Doortech 2000
A Gardner	N/A
D Heslop	Norsound Ltd

3.0 Description of Test

3.1 Description of Sample

Various door sets.

See Appendix 4 for individual test details and Appendix 5 for drawings. When cross referencing the detail in Appendices 4 and 5 with the SRL datasheets use the SRL Test Number.

Door frame fixed to test aperture and sealed at perimeter with mineral wool and mastic.

Sampling plan: Enough for test only

Sample condition: New

Details supplied by Norsound Ltd

Sample installed by Norsound Ltd

3.2 Sample Delivery date

28 May 2008

3.3 Test Procedures

The sample was mounted/located and tested in accordance with the relevant standard. The method and procedure is described in Appendix 1. The measurement uncertainty is given in Appendix 2.

4.0 Results

The results of the measurements and subsequent analysis are given in Appendix 3 and summarised in Appendix 4.

End of Text

Appendix 1

Test Procedure

Measurement of Sound Transmission in accordance with BS EN ISO 140-3 : 1995 - TP15

In the laboratory, airborne sound transmission is determined from the difference in sound pressure levels measured across a test sample installed between two reverberant rooms. The difference in measured sound pressure levels is corrected for the amount of absorption in the receiving room. The test is done under conditions which restrict the transmission of sound by paths other than directly through the sample. The source sound field is randomly incident on the sample.

The test sample is located and sealed in an aperture within the brick dividing wall between the two rectangular reverberant (i.e. acoustically "live") room, both of which are constructed from 215mm brick with reinforced concrete floors and roofs. The brick wall has dimensions of 4.8m wide x 3.1m high and 550mm nominal thickness and forms the whole of the common area between the two rooms.

One of the rooms is used as the receiving room and has a volume of 300 cubic metres. It is isolated from the surrounding structure and the adjoining room by the use of resilient mountings and seals ensuring good acoustic isolation. The adjoining source room has a volume of 115 cubic metres.

Broad band noise is produced in the source room from an electronic generator, power amplifier and loudspeaker. The resulting sound pressure levels in both rooms are sampled using a microphone mounted on an oscillating boom and connected to a real time analyser. The signal is filtered into one third octave band widths, integrated and averaged. The value obtained at each frequency is known as the average sound pressure level for either the source or the receiving room. The change in level across the test sample is termed the sound pressure level difference, i.e.

$$D = L_1 - L_2$$

where

D is the equivalent Sound Pressure level difference in dB

L₁ is the equivalent Sound Pressure level in the source room in dB

L₂ is the equivalent Sound Pressure level in the receiving room in dB

The Sound Reduction Index (R) also known by the American terminology Sound Transmission Loss, is defined as the number of decibels by which sound energy randomly incident on the test sample, is reduced in transmitting through it and is given by the formula:

$$R = D + 10 \log_{10} \frac{S}{A} \dots\dots \text{in decibels}$$

where

S is the area of the sample

A is the total absorption in the receiving room

both dimensions being in consistent units

The Sound Reduction Index is an expression of the laboratory sound transmission performance of a particular element or construction. It is a function of the mass, thickness, sealing method of mounting etc. and is independent of the overall area of the sample.

However, when an example of this construction is installed on site, the sound insulation obtained will depend upon its surface area, as well as the absorption in the receiving room. The larger the area the greater the sound energy transmitted. Also, the overall sound insulation is affected by the sound transmission through other building elements, some of which may have an inferior performance to the sample tested. In practice, therefore, the potential sound reduction index of a construction is not fully realised on site. Furthermore, the sound reduction index of a particular sample of that construction can only be measured accurately in a laboratory, because only under such controlled conditions can the sound transmission path be limited to the sample under test.

R_w is a single figure rating of sound insulation and is calculated in accordance with the relevant section of BS EN ISO 717-1:1997.

Appendix 2

Measurement Uncertainty BS EN ISO 140-3:1995 - TP15

The following values of uncertainty are based on a standard uncertainty multiplied by a coverage factor of $k = 2$, which provides a level of confidence of approximately 95%.

Frequency, Hz	Uncertainty, \pm dB
100	2.6
125	2.4
160	2.1
200	2.1
250	1.5
315	1.5
400	1.2
500	1.2
800	1.0
1000	1.0
1250	1.0
1600	1.0
2000	1.0
2500	1.0
3150	1.0



Appendix 3 - Data Sheets

Test Number :	3	Air temperature:	16.7 °C
Client:	Norsound Ltd	Air humidity:	77 %
Test Date:	29/05/2008	Receiving room volume	300 m3
Sample height:	2.115 m	Source room volume:	115 m3
Sample width:	1.006 m	Sample weight:	26.3 kg/m2
Product	Single leaf Strebord 44		
Identification:	Fully caulked		

Freq f Hz	Sound Reduction Index, dB	
	1/3 Oct	1/1 Oct
50+	16.3	18.0
63+	21.3	
80+	17.8	
100	23.6	24.6
125	23.3	
160	28.6	
200	27.5	29.3
250	29.5	
315	31.9	
400	33.3	34.2
500	34.7	
630	34.6	
800	33.3	30.6
1000	30.5	
1250	29.0	
1600	30.7	32.6
2000	33.0	
2500	35.0	
3150	36.5	36.7
4000	37.6	
5000	36.0	
6300+	38.7	40.5
8000+	40.9	
10000+	42.9	
Average 100-3150	30.9	

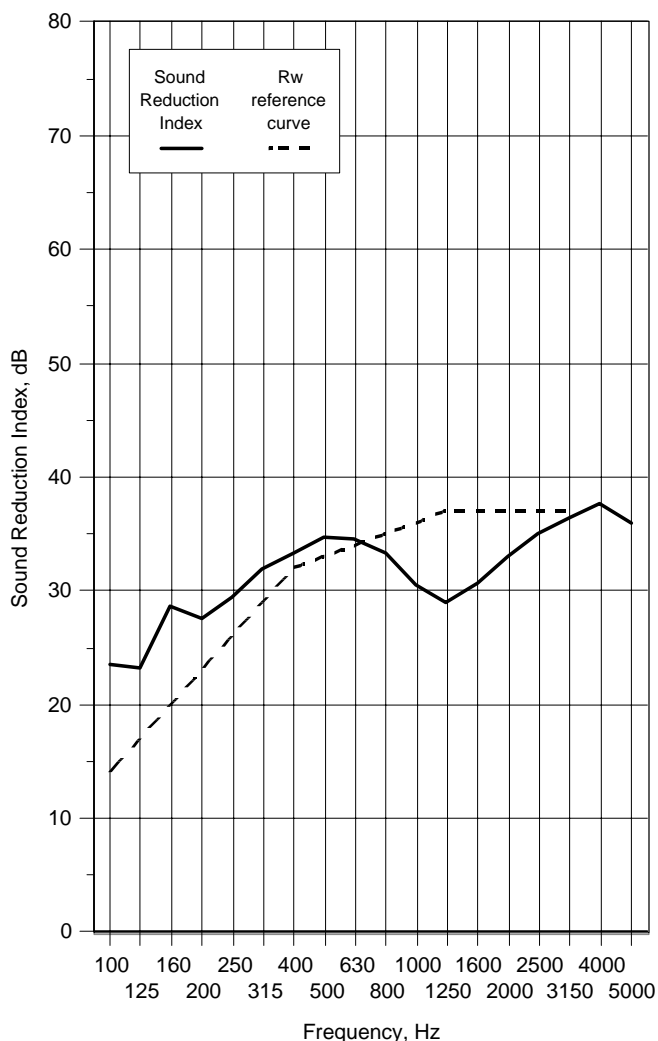

Rating according to BS EN ISO 717-1:1997

Rw(C;Ctr)= **33 (-1;-2)** dB

Notes * designates measurement corrected for background

designates limit of measurement due to background

+ designates frequency beyond standard and not UKAS accredited

v1.6

Test Number :	4	Air temperature:	16.8 °C
Client:	Norsound Ltd	Air humidity:	80 %
Test Date:	29/05/2008	Receiving room volume	300 m3
Sample height:	2.115 m	Source room volume:	115 m3
Sample width:	1.006 m	Sample weight:	26.3 kg/m2
Product	Single leaf Strebord 44		
Identification:	Threshold=810		
	Head, hanging jamb & closing jamb=710		

Freq f Hz	Sound Reduction Index, dB	
	1/3 Oct	1/1 Oct
50+	18.2	18.7
63+	23.1	
80+	16.9	
100	22.4	24.0
125	23.2	
160	28.1	
200	27.0	28.8
250	29.0	
315	31.2	
400	32.2	33.0
500	33.7	
630	33.4	
800	31.9	29.3
1000	29.2	
1250	27.7	
1600	29.5	31.2
2000	31.5	
2500	33.2	
3150	34.4	34.6
4000	34.8	
5000	34.4	
6300+	37.1	38.6
8000+	39.4	
10000+	40.0	
Average 100-3150	29.9	

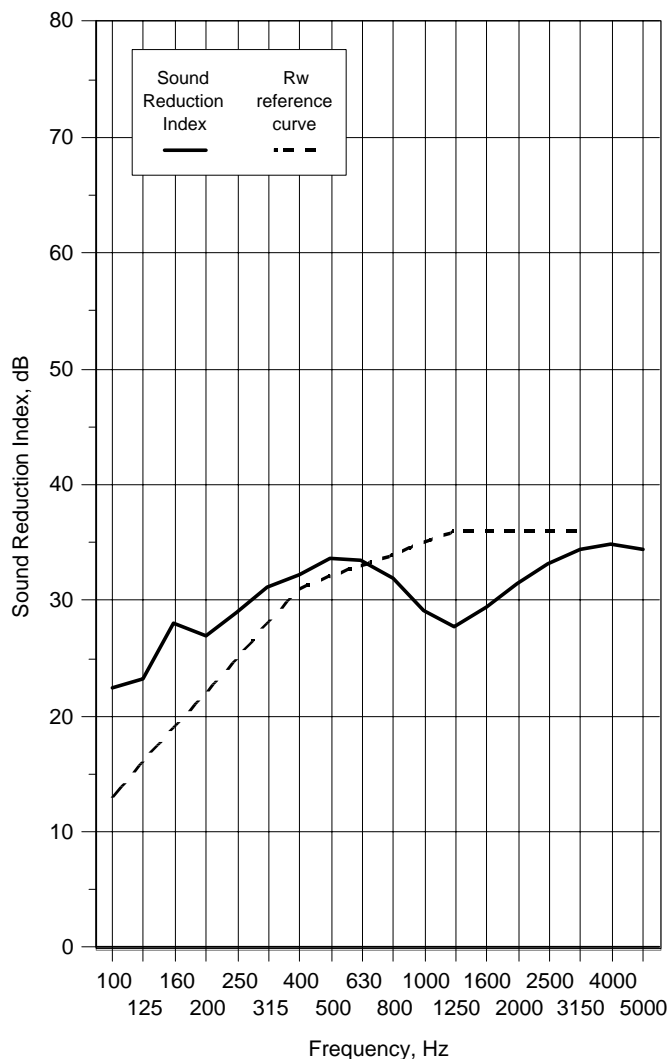

Rating according to BS EN ISO 717-1:1997

Rw(C;Ctr)= **32 (-1;-2)** dB

Notes * designates measurement corrected for background

designates limit of measurement due to background

+ designates frequency beyond standard and not UKAS accredited

v1.6

Test Number :	5	Air temperature:	16.8 °C
Client:	Norsound Ltd	Air humidity:	80 %
Test Date:	29/05/2008	Receiving room volume	300 m3
Sample height:	2.115 m	Source room volume:	115 m3
Sample width:	1.006 m	Sample weight:	26.3 kg/m2
Product	Single leaf Strebord 44		
Identification:	Threshold=810		
	Head, hanging jamb & closing jamb=710		

Freq f Hz	Sound Reduction Index, dB	
	1/3 Oct	1/1 Oct
50+	20.6	19.7
63+	23.1	
80+	17.3	
100	22.4	24.0
125	23.2	
160	28.3	
200	26.9	28.6
250	28.6	
315	31.4	
400	32.1	32.9
500	33.6	
630	33.1	
800	31.3	28.5
1000	28.9	
1250	26.6	
1600	28.4	30.4
2000	30.9	
2500	33.1	
3150	34.4	34.4
4000	34.6	
5000	34.1	
6300+	37.2	38.7
8000+	39.3	
10000+	40.1	
Average 100-3150	29.6	

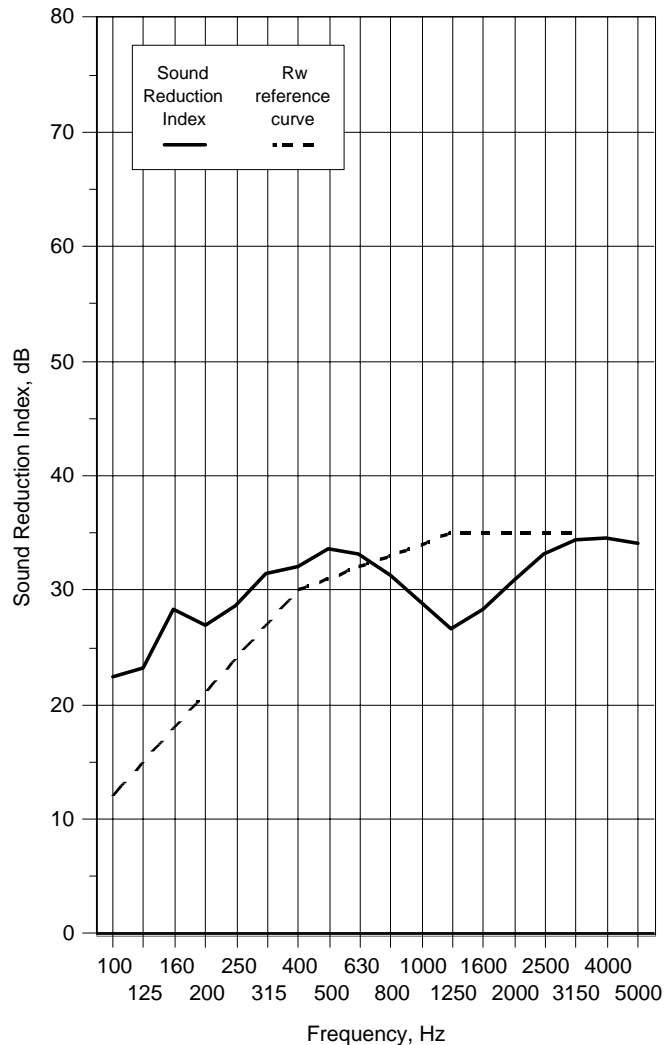

Rating according to BS EN ISO 717-1:1997

Rw(C;Ctr)= **31 (-1;-2)** dB

Notes * designates measurement corrected for background
 # designates limit of measurement due to background
 + designates frequency beyond standard and not UKAS accredited

v1.6

Test Number :	8	Air temperature:	16.7 °C
Client:	Norsound Ltd	Air humidity:	80 %
Test Date:	30/05/2008	Receiving room volume	300 m3
Sample height:	2.115 m	Source room volume:	115 m3
Sample width:	1.006 m	Sample weight:	52.6 kg/m2
Product	2xSingle leaf Strebord 44		
Identification:	Threshold=810 to each leaf		
	Head, hanging jamb & closing jamb=710 to each leaf		

Freq f Hz	Sound Reduction Index, dB		
	1/3 Oct	1/1 Oct	
50+	23.2	19.3	
63+	23.2		
80+	15.9		
100	22.4	25.8	
125	28.1		
160	32.4		
200	28.8	31.4	
250	31.5		
315	37.6		
400	40.0	42.1	
500	43.5		
630	44.3		
800	41.5	39.8	
1000	37.9		
1250	40.8		
1600	43.3	43.7	
2000	43.0		
2500	45.2		
3150	56.2	*	57.0
4000	56.0	*	
5000	59.5	#	
6300+	59.8	#	60.0
8000+	59.9	#	
10000+	60.5	#	
Average 100-3150	38.5		

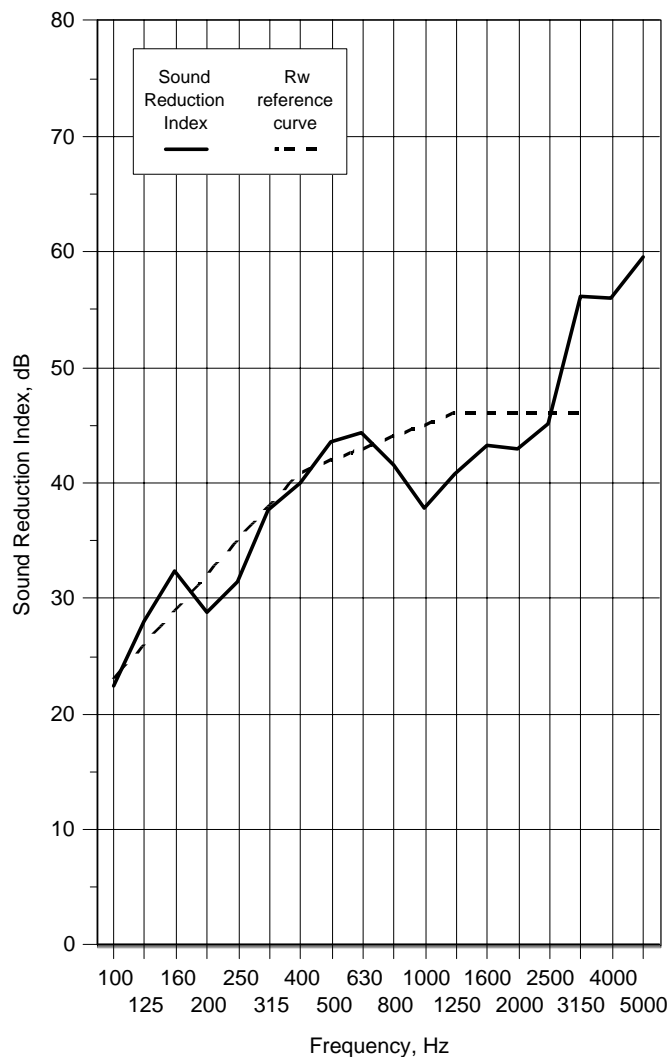

Rating according to BS EN ISO 717-1:1997

Rw(C;Ctr)= **42 (-2;-5) dB**

Notes * designates measurement corrected for background

designates limit of measurement due to background

+ designates frequency beyond standard and not UKAS accredited

v1.6

Test Number :	9	Air temperature:	16.6 °C
Client:	Norsound Ltd	Air humidity:	77 %
Test Date:	30/05/2008	Receiving room volume	300 m3
Sample height:	2.115 m	Source room volume:	115 m3
Sample width:	1.006 m	Sample weight:	31.4 kg/m2
Product	Single leaf Strebord 54		
Identification:	Fully caulked		

Freq f Hz	Sound Reduction Index, dB	
	1/3 Oct	1/1 Oct
50+	21.2	20.3
63+	21.2	
80+	18.9	
100	23.8	24.8
125	23.7	
160	28.6	
200	27.7	29.7
250	29.8	
315	33.2	
400	34.6	35.1
500	35.8	
630	35.1	
800	33.1	31.6
1000	30.5	
1250	31.6	
1600	33.8	35.6
2000	36.3	
2500	37.8	
3150	39.1	38.6
4000	37.3	
5000	40.1	
6300+	42.0	44.0
8000+	44.6	
10000+	46.4	
Average 100-3150	32.2	

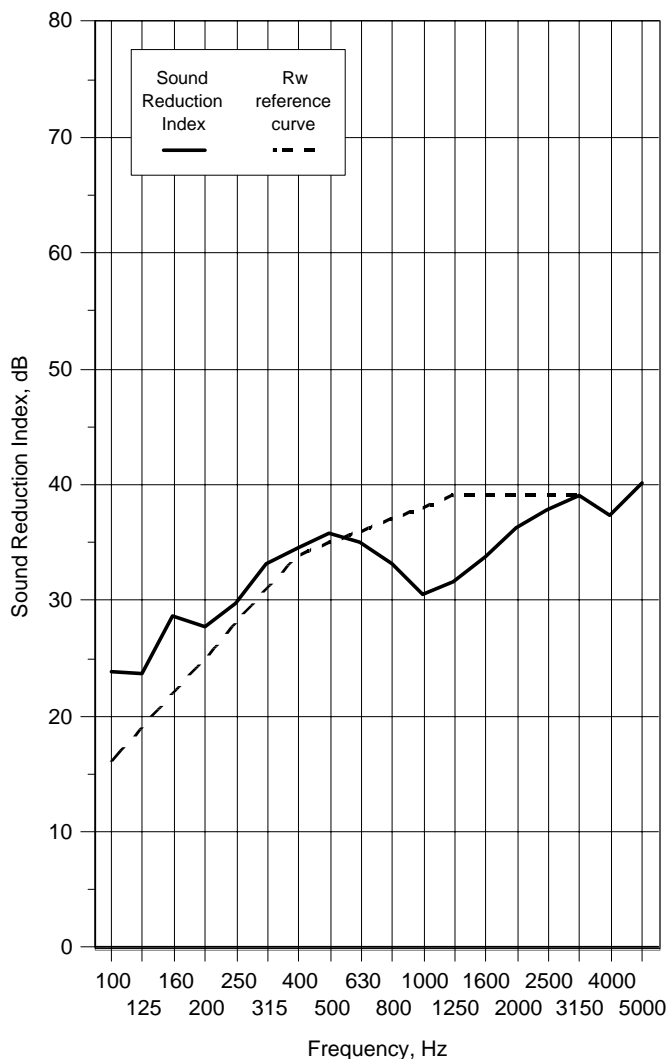

Rating according to BS EN ISO 717-1:1997

Rw(C;Ctr)= **35 (-1;-3)** dB

Notes * designates measurement corrected for background

designates limit of measurement due to background

+ designates frequency beyond standard and not UKAS accredited

v1.6

Test Number :	10	Air temperature:	16.6 °C
Client:	Norsound Ltd	Air humidity:	77 %
Test Date:	30/05/2008	Receiving room volume	300 m3
Sample height:	2.115 m	Source room volume:	115 m3
Sample width:	1.006 m	Sample weight:	31.4 kg/m2
Product	Single leaf Strebord 54		
Identification:	Threshold=810		
	Head, hanging jamb & closing jamb=720 + 710		

Freq f Hz	Sound Reduction Index, dB	
	1/3 Oct	1/1 Oct
50+	15.3	17.3
63+	20.1	
80+	17.7	
100	24.2	25.3
125	24.2	
160	28.9	
200	28.1	29.8
250	29.8	
315	32.7	
400	33.9	34.3
500	34.8	
630	34.1	
800	31.5	29.4
1000	28.2	
1250	29.1	
1600	31.4	32.7
2000	33.2	
2500	33.8	
3150	33.8	35.0
4000	34.9	
5000	36.9	
6300+	38.7	40.6
8000+	41.2	
10000+	42.8	
Average 100-3150	30.7	

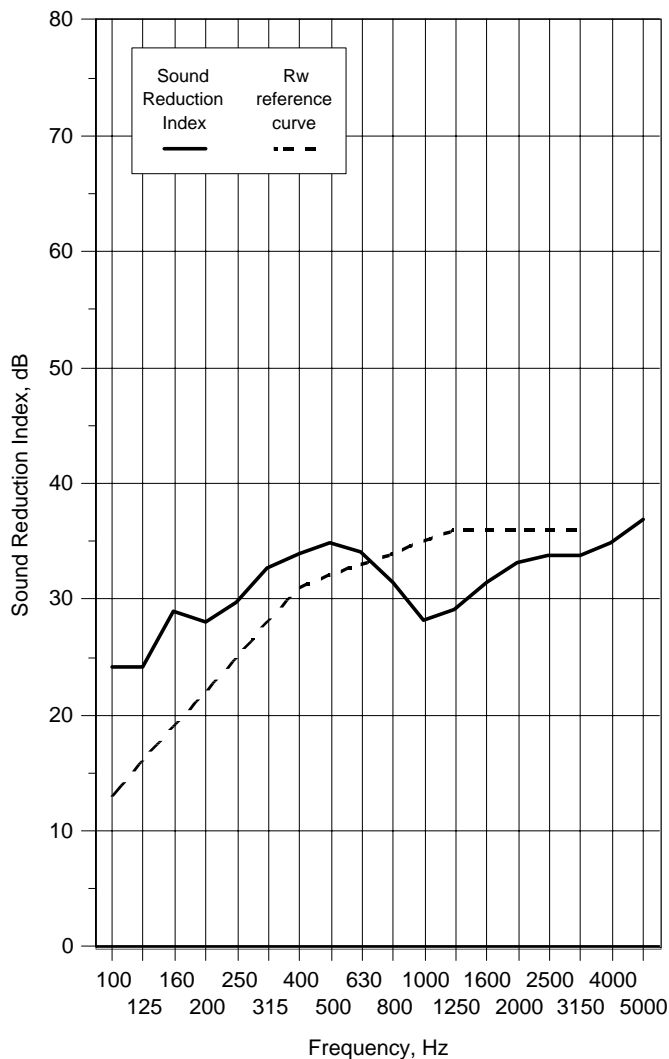

Rating according to BS EN ISO 717-1:1997

Rw(C;Ctr)= **32 (-1;-1)** dB

Notes * designates measurement corrected for background
 # designates limit of measurement due to background
 + designates frequency beyond standard and not UKAS accredited

v1.6

Test Number :	11	Air temperature:	16.7 °C
Client:	Norsound Ltd	Air humidity:	78 %
Test Date:	30/05/2008	Receiving room volume	300 m3
Sample height:	2.115 m	Source room volume:	115 m3
Sample width:	1.006 m	Sample weight:	31.4 kg/m2
Product	Single leaf Strebord 54		
Identification:	Threshold=810		
	Head, hanging jamb & closing jamb=720+710		

Freq f Hz	Sound Reduction Index, dB	
	1/3 Oct	1/1 Oct
50+	17.1	18.3
63+	20.8	
80+	17.7	
100	24.6	25.3
125	24.0	
160	28.7	
200	28.3	29.7
250	29.5	
315	32.2	
400	33.9	34.5
500	35.1	
630	34.6	
800	32.0	30.2
1000	29.0	
1250	30.1	
1600	32.0	33.0
2000	33.5	
2500	33.8	
3150	34.5	34.9
4000	34.1	
5000	36.3	
6300+	37.9	39.9
8000+	40.6	
10000+	42.4	
Average 100-3150	31.0	

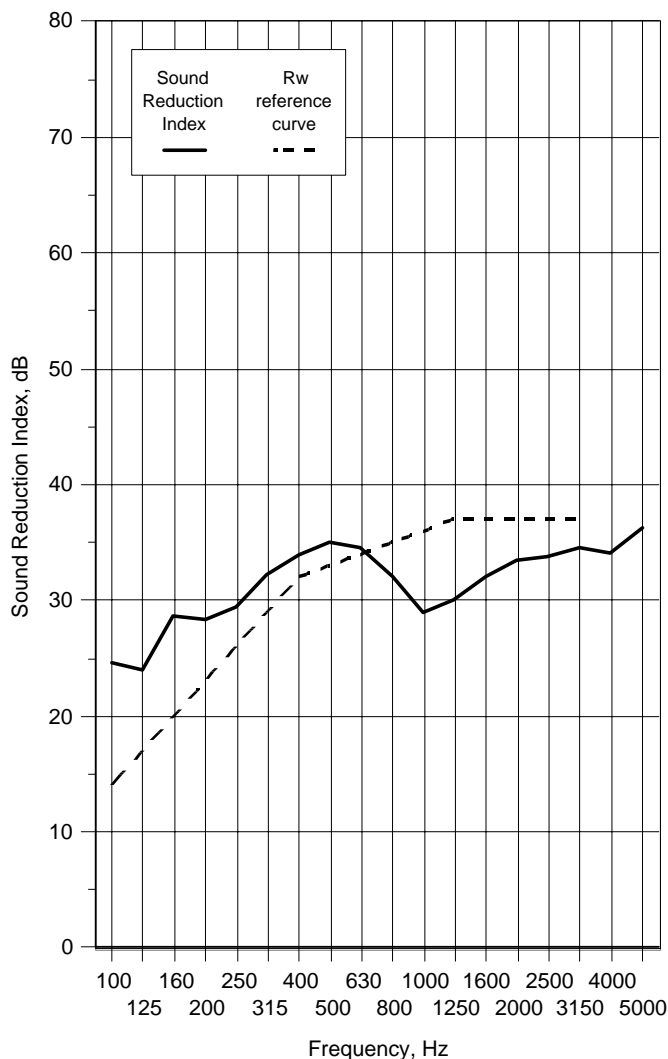

Rating according to BS EN ISO 717-1:1997

Rw(C;Ctr)= **33 (-1;-2)** dB

Notes * designates measurement corrected for background

designates limit of measurement due to background

+ designates frequency beyond standard and not UKAS accredited

v1.6

Test Number :	12	Air temperature:	16.8 °C
Client:	Norsound Ltd	Air humidity:	78 %
Test Date:	30/05/2008	Receiving room volume	300 m3
Sample height:	2.115 m	Source room volume:	115 m3
Sample width:	1.006 m	Sample weight:	31.4 kg/m2
Product	Single leaf Strebord 54		
Identification:	Threshold=810 + 650A threshold		
	Head, hanging jamb & closing jamb=720+710+755		

Freq f Hz	Sound Reduction Index, dB	
	1/3 Oct	1/1 Oct
50+	17.4	18.9
63+	21.2	
80+	18.9	
100	25.0	25.7
125	24.3	
160	29.5	30.1
200	28.5	
250	30.0	
315	33.1	35.1
400	34.4	
500	35.7	
630	35.4	31.1
800	32.8	
1000	30.0	
1250	31.0	34.5
1600	32.9	
2000	34.9	
2500	36.5	37.4
3150	37.5	
4000	36.3	
5000	38.9	42.8
6300+	40.8	
8000+	43.7	
10000+	45.1	
Average 100-3150	32.0	

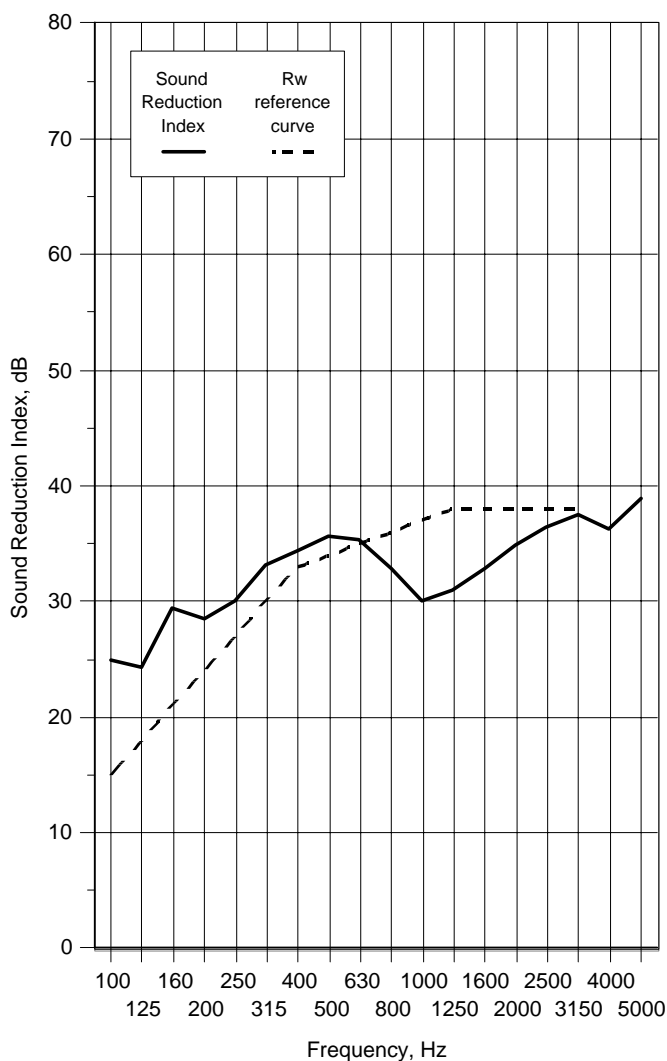

Rating according to BS EN ISO 717-1:1997

Rw(C;Ctr)= **34 (-1;-2) dB**

Notes * designates measurement corrected for background
 # designates limit of measurement due to background
 + designates frequency beyond standard and not UKAS accredited

v1.6

Test Number :	13	Air temperature:	16.8 °C
Client:	Norsound Ltd	Air humidity:	78 %
Test Date:	30/05/2008	Receiving room volume	300 m3
Sample height:	2.115 m	Source room volume:	115 m3
Sample width:	1.006 m	Sample weight:	31.4 kg/m2
Product	Single leaf Strebord 54		
Identification:	Threshold=650A threshold		
	Head, hanging jamb & closing jamb=755		

Freq f Hz	Sound Reduction Index, dB	
	1/3 Oct	1/1 Oct
50+	24.5	21.5
63+	26.1	
80+	18.2	
100	23.7	25.1
125	24.2	
160	28.9	
200	28.7	30.1
250	29.9	
315	32.6	
400	33.1	33.2
500	34.1	
630	32.6	
800	30.3	28.3
1000	27.7	
1250	27.5	
1600	29.1	31.1
2000	32.0	
2500	33.5	
3150	34.9	34.2
4000	33.9	
5000	33.8	
6300+	34.7	35.4
8000+	35.7	
10000+	36.0	
Average 100-3150	30.2	

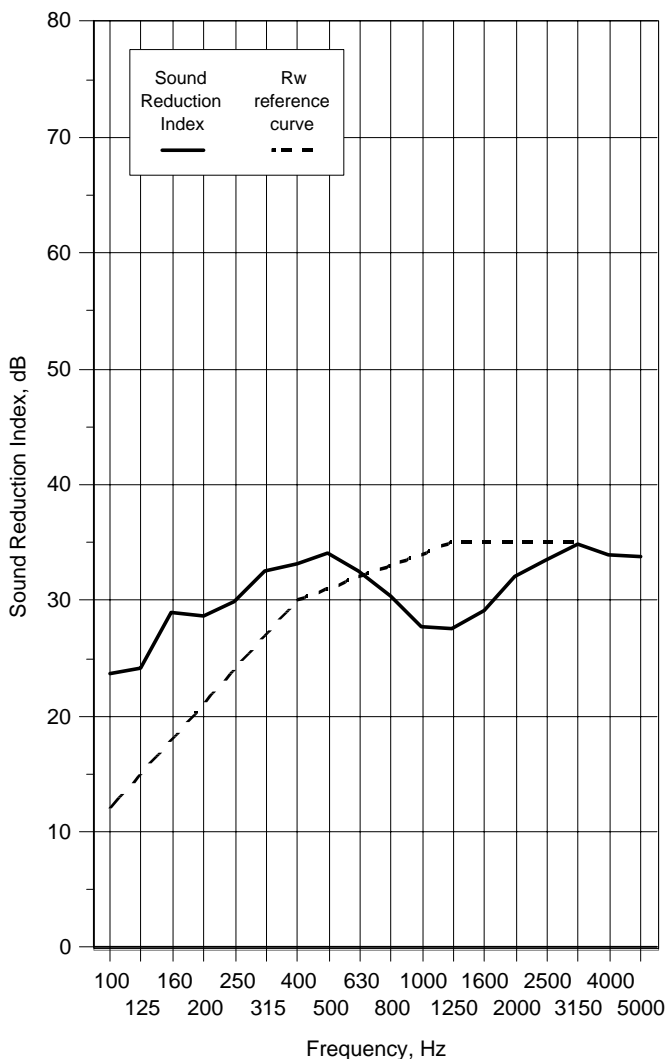

Rating according to BS EN ISO 717-1:1997

Rw(C;Ctr)= **31 (-1;-1) dB**

Notes * designates measurement corrected for background
 # designates limit of measurement due to background
 + designates frequency beyond standard and not UKAS accredited

v1.6

Test Number :	15	Air temperature:	16.3 °C
Client:	Norsound Ltd	Air humidity:	74 %
Test Date:	02/06/2008	Receiving room volume	300 m3
Sample height:	2.115 m	Source room volume:	115 m3
Sample width:	1.006 m	Sample weight:	31.4 kg/m2
Product	Single leaf Strebord 54		
Identification:	Threshold=810		
	Head, hanging jamb & closing jamb=720		

Freq f Hz	Sound Reduction Index, dB	
	1/3 Oct	1/1 Oct
50+	19.6	18.8
63+	18.0	
80+	18.9	
100	21.4	23.5
125	23.7	
160	27.5	
200	28.1	29.5
250	29.5	
315	31.6	
400	32.3	32.9
500	34.1	
630	32.5	
800	29.6	29.1
1000	28.4	
1250	29.4	
1600	31.1	32.4
2000	32.6	
2500	33.8	
3150	35.5	36.3
4000	36.0	
5000	37.9	
6300+	39.8	40.0
8000+	40.2	
10000+	40.0	
Average 100-3150	30.1	

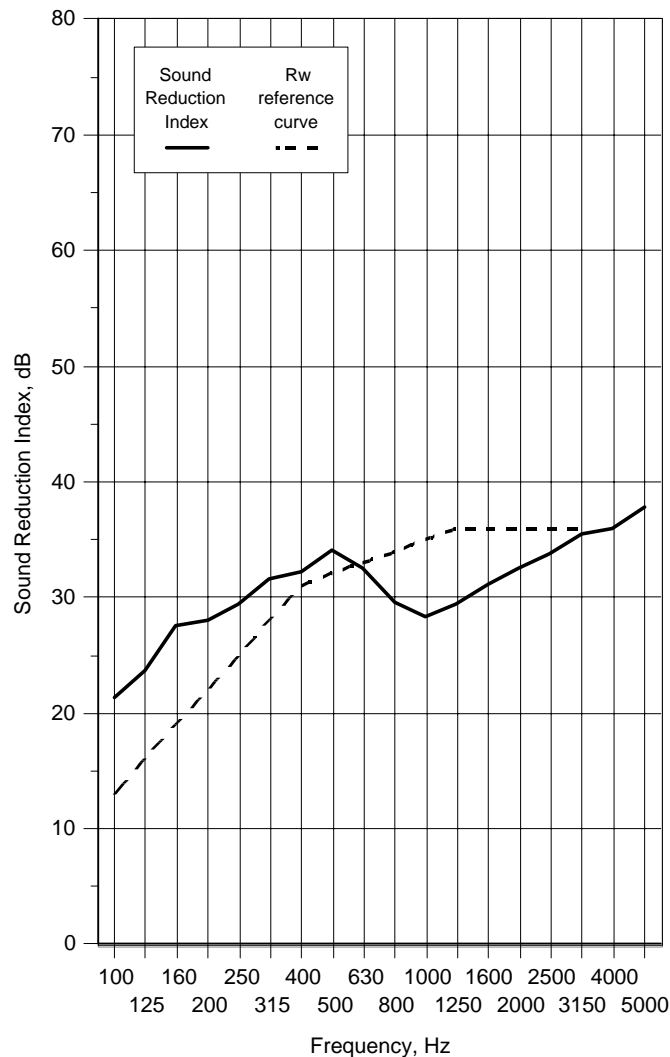

Rating according to BS EN ISO 717-1:1997

Rw(C;Ctr)= **32 (-1;-2)** dB

Notes * designates measurement corrected for background

designates limit of measurement due to background

+ designates frequency beyond standard and not UKAS accredited

v1.6

Test Number :	16	Air temperature:	16.3 °C
Client:	Norsound Ltd	Air humidity:	74 %
Test Date:	02/06/2008	Receiving room volume	300 m ³
Sample height:	2.115 m	Source room volume:	115 m ³
Sample width:	1.006 m	Sample weight:	31.4 kg/m ²
Product	Single leaf Strebord 54		
Identification:	Threshold=810		
	Head, hanging jamb & closing jamb=710		

Freq f Hz	Sound Reduction Index, dB	
	1/3 Oct	1/1 Oct
50+	20.6	
63+	17.8	18.5
80+	17.6	
100	20.2	
125	23.9	22.8
160	26.8	
200	27.2	
250	29.3	28.9
315	31.2	
400	31.9	
500	33.9	32.7
630	32.6	
800	29.7	
1000	29.0	29.6
1250	30.1	
1600	31.5	
2000	33.3	32.8
2500	34.0	
3150	35.2	
4000	35.8	36.1
5000	37.8	
6300+	40.1	
8000+	41.0	41.3
10000+	43.6	
Average 100-3150	30.0	

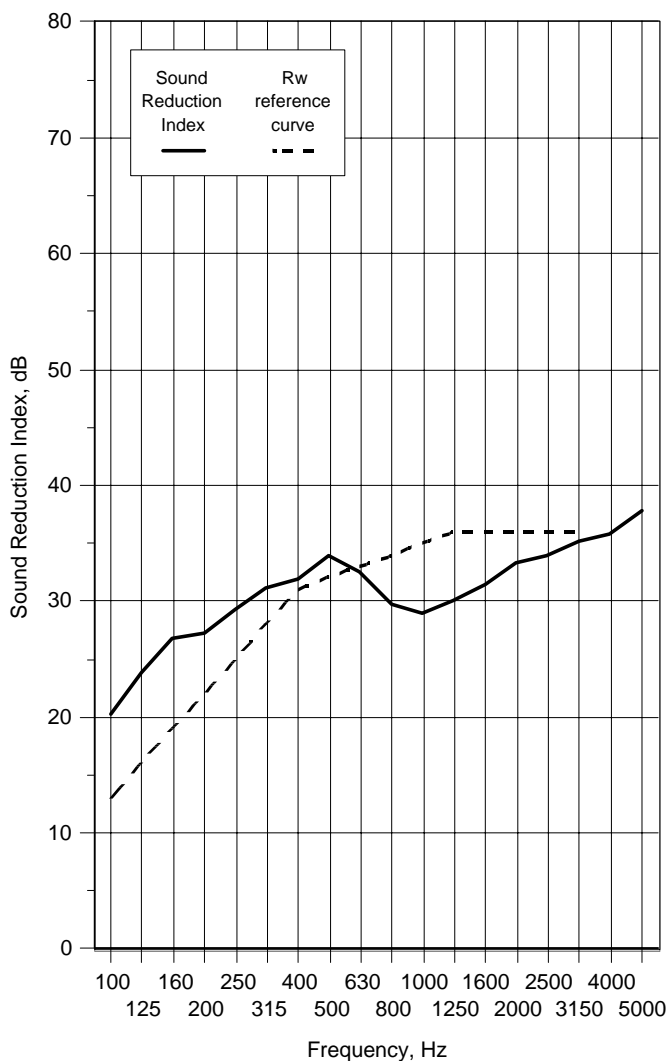

Rating according to BS EN ISO 717-1:1997

Rw(C;Ctr)= **32 (-1;-2) dB**

Notes * designates measurement corrected for background

designates limit of measurement due to background

+ designates frequency beyond standard and not UKAS accredited

v1.6

Test Number :	17	Air temperature:	16.4 °C
Client:	Norsound Ltd	Air humidity:	74 %
Test Date:	02/06/2008	Receiving room volume	300 m3
Sample height:	2.115 m	Source room volume:	115 m3
Sample width:	1.006 m	Sample weight:	31.4 kg/m2
Product	Single leaf Strebord 54		
Identification:	Threshold=810		
	Head, hanging jamb & closing jamb=710		

Freq f Hz	Sound Reduction Index, dB	
	1/3 Oct	1/1 Oct
50+	19.3	17.9
63+	17.3	
80+	17.5	
100	20.8	23.3
125	24.3	
160	27.1	
200	28.2	29.7
250	30.1	
315	31.3	
400	31.8	32.5
500	33.5	
630	32.4	
800	29.8	29.5
1000	28.7	
1250	30.0	
1600	31.2	32.5
2000	33.0	
2500	33.7	
3150	34.8	35.8
4000	35.5	
5000	37.6	
6300+	39.5	40.8
8000+	40.6	
10000+	43.2	
Average 100-3150	30.0	

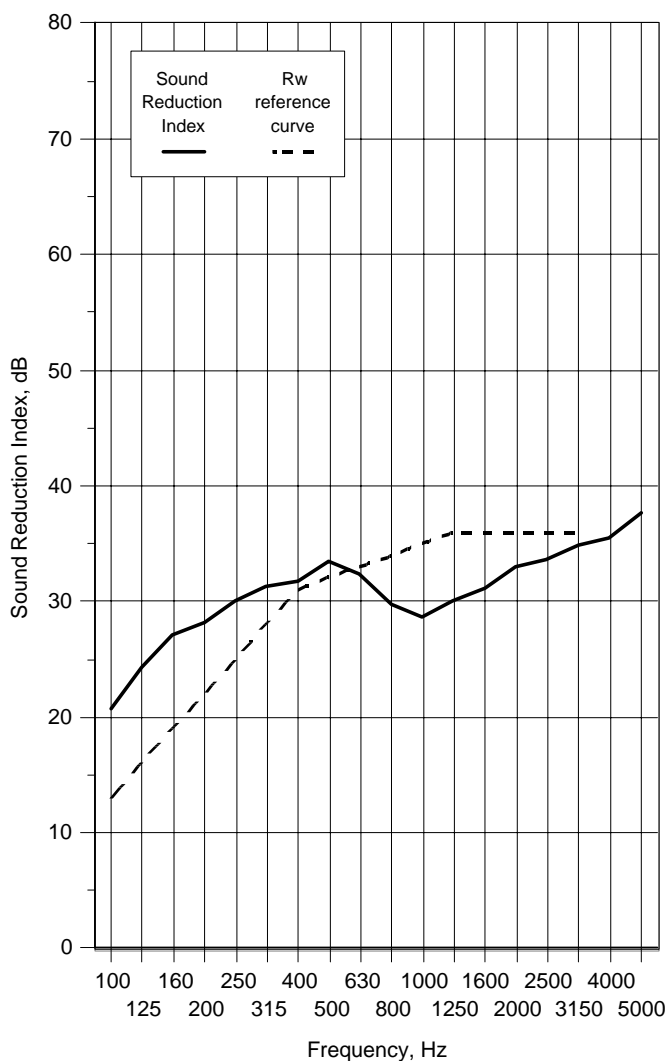

Rating according to BS EN ISO 717-1:1997

Rw(C;Ctr)= **32 (-1;-2)** dB

Notes * designates measurement corrected for background
 # designates limit of measurement due to background
 + designates frequency beyond standard and not UKAS accredited

v1.6

Test Number :	18	Air temperature:	16.5 °C
Client:	Norsound Ltd	Air humidity:	75 %
Test Date:	02/06/2008	Receiving room volume	300 m3
Sample height:	2.115 m	Source room volume:	115 m3
Sample width:	1.006 m	Sample weight:	31.4 kg/m2
Product	Single leaf Strebord 54		
Identification:	Threshold=810 + 615 threshold		
	Head, hanging jamb & closing jamb=710		

Freq f Hz	Sound Reduction Index, dB	
	1/3 Oct	1/1 Oct
50+	18.8	16.6
63+	15.2	
80+	16.6	
100	19.9	22.6
125	24.1	
160	26.5	
200	26.3	28.1
250	28.8	
315	30.3	
400	30.3	30.8
500	31.9	
630	30.3	
800	28.2	28.3
1000	28.1	
1250	28.8	
1600	30.5	31.9
2000	32.7	
2500	32.8	
3150	33.1	34.2
4000	33.9	
5000	36.0	
6300+	38.9	40.2
8000+	40.1	
10000+	42.1	
Average 100-3150	28.9	

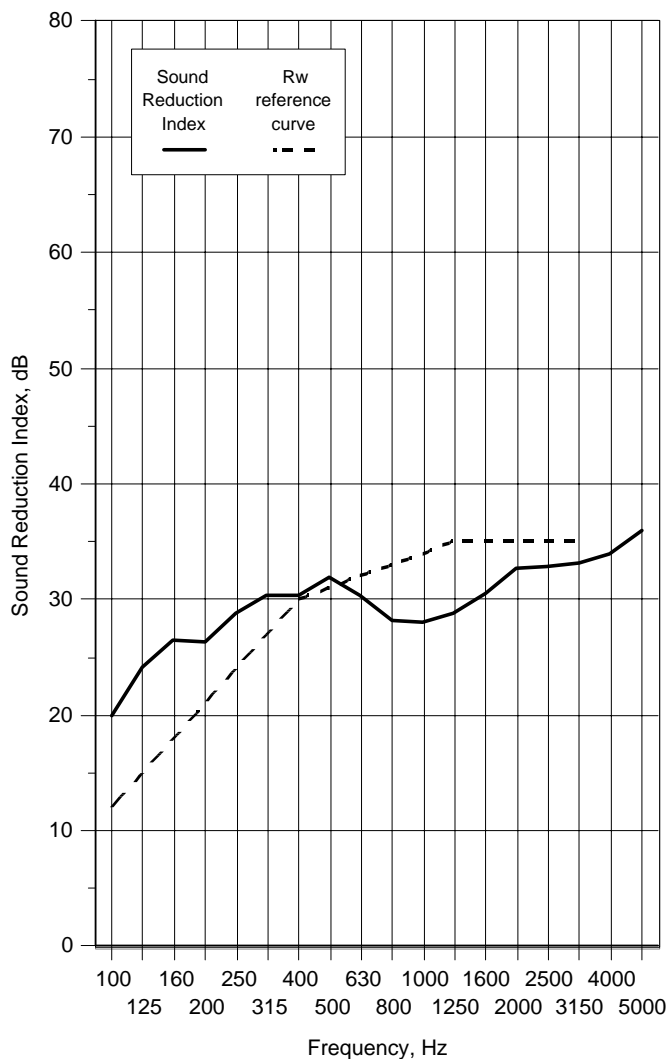

Rating according to BS EN ISO 717-1:1997

Rw(C;Ctr)= **31 (-1;-2)** dB

Notes * designates measurement corrected for background

designates limit of measurement due to background

+ designates frequency beyond standard and not UKAS accredited

v1.6

Test Number :	19	Air temperature:	16.5 °C
Client:	Norsound Ltd	Air humidity:	76 %
Test Date:	02/06/2008	Receiving room volume	300 m3
Sample height:	2.115 m	Source room volume:	115 m3
Sample width:	1.006 m	Sample weight:	kg/m2
Product	Single leaf Strebord 54		
Identification:	Threshold=850 used with 615 threshold Head, hanging jamb & closing jamb=710		

Freq f Hz	Sound Reduction Index, dB	
	1/3 Oct	1/1 Oct
50+	21.6	17.6
63+	17.1	
80+	15.9	
100	19.6	22.5
125	24.0	
160	27.5	
200	26.2	28.2
250	28.8	
315	31.1	
400	31.1	31.8
500	32.8	
630	31.6	
800	29.1	29.0
1000	28.5	
1250	29.5	
1600	30.0	31.5
2000	32.0	
2500	32.9	
3150	34.0	34.9
4000	34.5	
5000	36.6	
6300+	39.0	40.1
8000+	39.9	
10000+	41.9	
Average 100-3150	29.3	

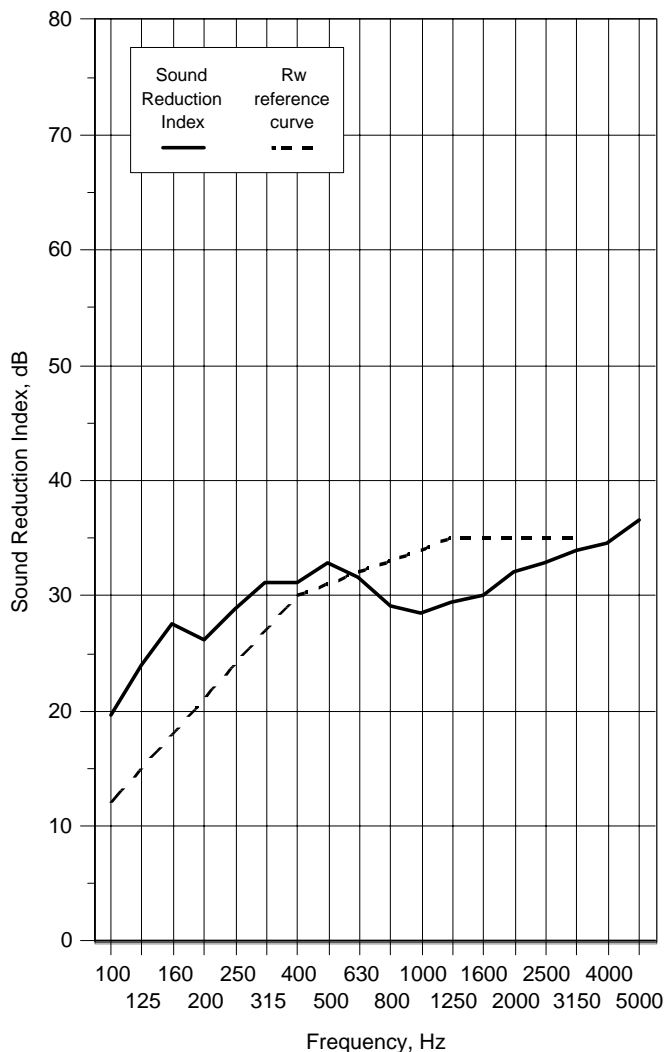

Rating according to BS EN ISO 717-1:1997

Rw(C;Ctr)= **31 (0;-2) dB**

Notes * designates measurement corrected for background
 # designates limit of measurement due to background
 + designates frequency beyond standard and not UKAS accredited

v1.6

Test Number : 20 **Air temperature:** 16.5 °C
Client: Norsound Ltd **Air humidity:** 76 %
Test Date: 02/06/2008 **Receiving room volume** 300 m3
Sample height: 2.115 m **Source room volume:** 115 m3
Sample width: 1.006 m **Sample weight:** 31.4 kg/m2
Product Single leaf Strebord 54
Identification: Threshold=2x720 used with 615 threshold
 Head, hanging jamb & closing jamb=710

Freq f Hz	Sound Reduction Index, dB	
	1/3 Oct	1/1 Oct
50+	22.7	18.6
63+	17.4	
80+	17.4	
100	20.8	22.9
125	22.8	
160	27.4	
200	26.3	28.1
250	28.6	
315	30.7	
400	31.5	32.4
500	33.5	
630	32.3	
800	29.6	29.4
1000	28.9	
1250	29.9	
1600	30.7	31.8
2000	32.3	
2500	32.7	
3150	34.0	35.2
4000	35.0	
5000	37.0	
6300+	39.4	40.8
8000+	40.3	
10000+	43.8	
Average 100-3150	29.5	

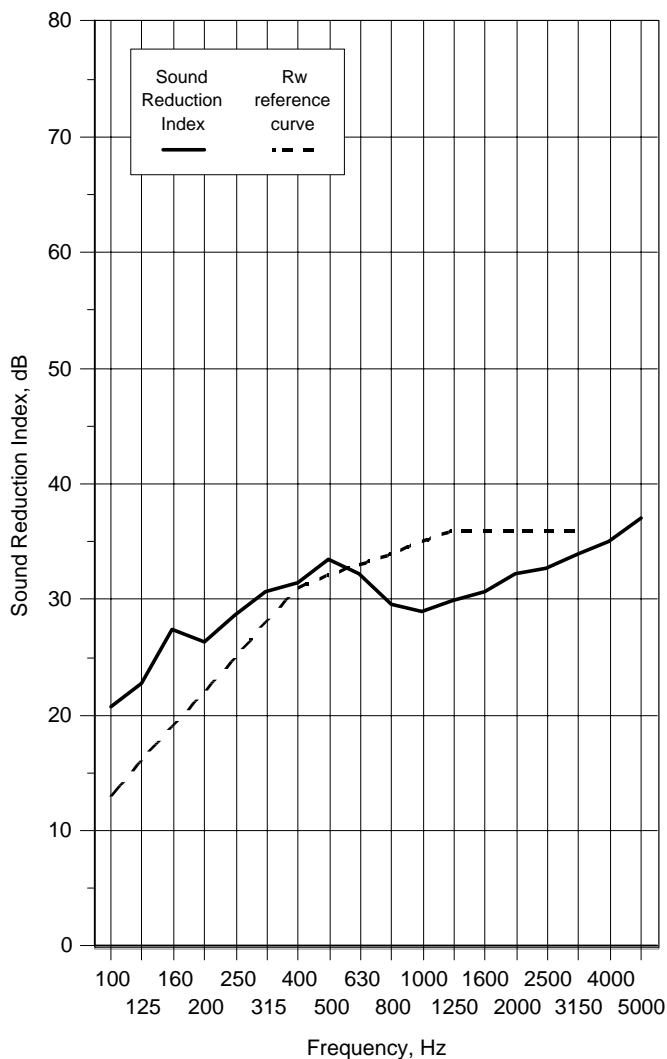

Rating according to BS EN ISO 717-1:1997

Rw(C;Ctr)= **32 (-1;-2)** dB

Notes * designates measurement corrected for background

designates limit of measurement due to background

+ designates frequency beyond standard and not UKAS accredited

v1.6

Test Number : 21
Client: Norsound Ltd
Test Date: 02/06/2008
Sample height: 2.115 m
Sample width: 1.006 m
Product Single leaf Strebord 54
Identification: Threshold=2x720 used with 630 threshold
 Head, hanging jamb & closing jamb=710
Air temperature: 16.6 °C
Air humidity: 75 %
Receiving room volume 300 m3
Source room volume: 115 m3
Sample weight: 31.4 kg/m2

Freq f Hz	Sound Reduction Index, dB	
	1/3 Oct	1/1 Oct
50+	22.8	19.0
63+	17.8	
80+	18.0	
100	20.4	22.6
125	22.6	
160	27.5	
200	26.2	28.3
250	29.0	
315	31.0	
400	31.5	32.3
500	33.3	
630	32.4	
800	29.8	29.9
1000	29.4	
1250	30.7	
1600	31.8	33.8
2000	34.6	
2500	35.9	
3150	37.0	37.0
4000	36.2	
5000	37.8	
6300+	40.1	41.4
8000+	40.9	
10000+	44.2	
Average 100-3150	30.2	

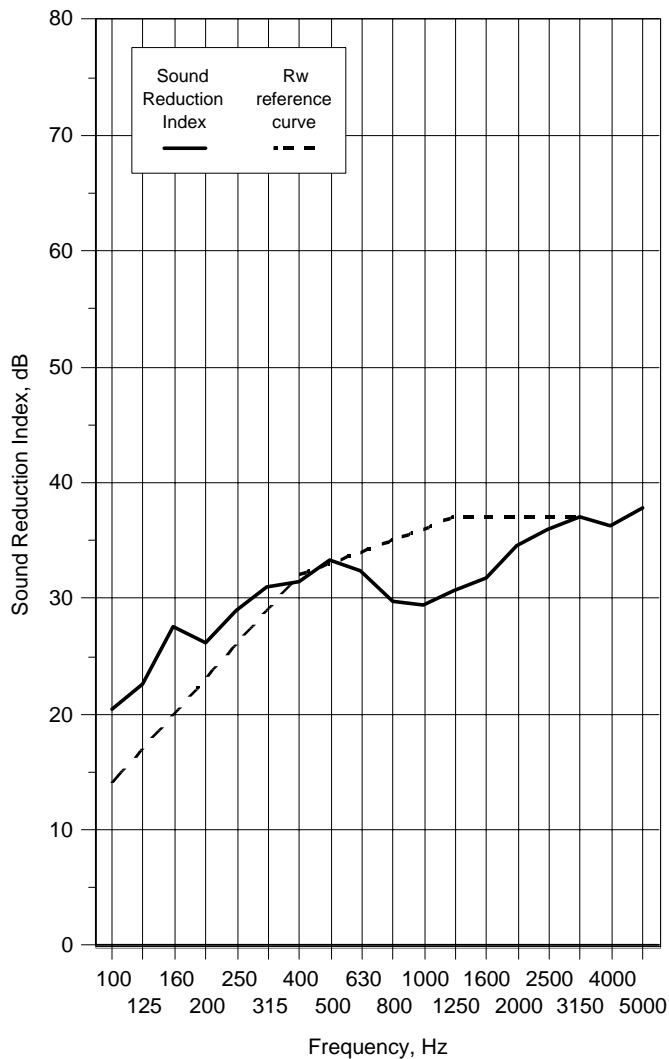

Rating according to BS EN ISO 717-1:1997

Rw(C;Ctr)= **33 (-1;-3) dB**

Notes * designates measurement corrected for background
 # designates limit of measurement due to background
 + designates frequency beyond standard and not UKAS accredited

v1.6

Test Number :	22	Air temperature:	16.6 °C
Client:	Norsound Ltd	Air humidity:	75 %
Test Date:	02/06/2008	Receiving room volume	300 m ³
Sample height:	2.115 m	Source room volume:	115 m ³
Sample width:	1.006 m	Sample weight:	31.4 kg/m ²
Product	Single leaf Strebord 54		
Identification:	Threshold=810 used with 650 threshold Head, hanging jamb & closing jamb=710		

Freq f Hz	Sound Reduction Index, dB	
	1/3 Oct	1/1 Oct
50+	20.2	18.8
63+	18.0	
80+	18.5	
100	20.9	23.1
125	23.2	
160	27.6	
200	27.1	29.0
250	29.6	
315	31.4	
400	32.0	32.9
500	33.7	
630	33.2	
800	30.2	30.0
1000	29.5	
1250	30.3	
1600	31.6	33.5
2000	34.3	
2500	35.6	
3150	36.7	37.2
4000	36.5	
5000	38.5	
6300+	41.0	42.6
8000+	42.5	
10000+	45.6	
Average 100-3150	30.4	

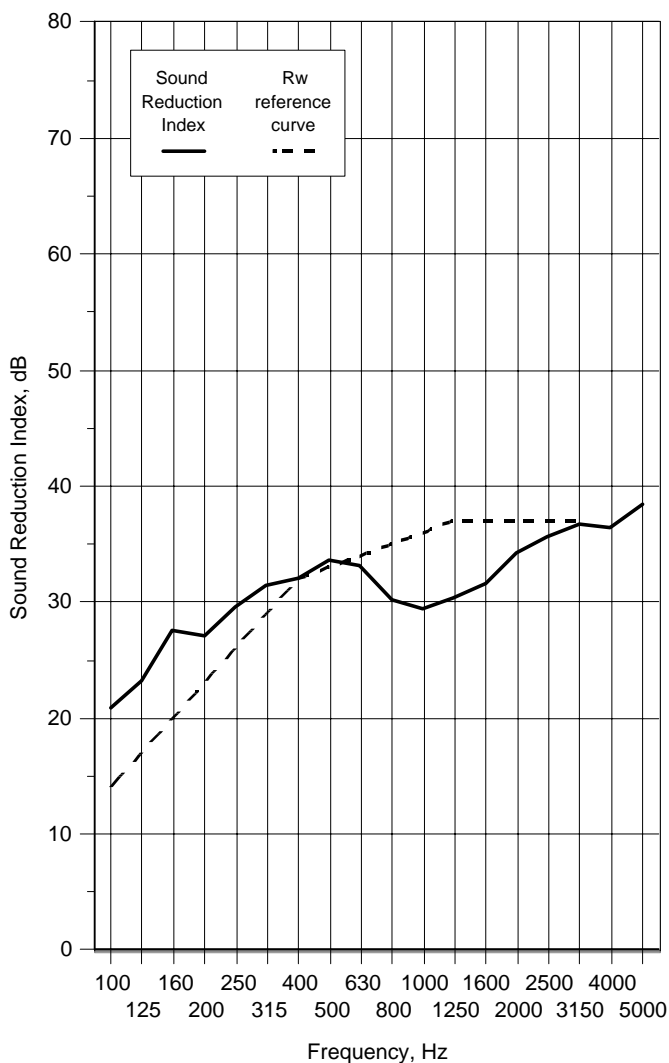

Rating according to BS EN ISO 717-1:1997

Rw(C;Ctr)= **33 (-1;-3)** dB

Notes * designates measurement corrected for background

designates limit of measurement due to background

+ designates frequency beyond standard and not UKAS accredited

v1.6

Test Number :	23	Air temperature:	16.6 °C
Client:	Norsound Ltd	Air humidity:	75 %
Test Date:	02/06/2008	Receiving room volume	300 m ³
Sample height:	2.115 m	Source room volume:	115 m ³
Sample width:	1.006 m	Sample weight:	31.4 kg/m ²
Product	Single leaf Strebord 54		
Identification:	Threshold=2x720 used with 650 threshold Head, hanging jamb & closing jamb=710		

Freq f Hz	Sound Reduction Index, dB	
	1/3 Oct	1/1 Oct
50+	21.6	19.2
63+	17.8	
80+	19.0	
100	20.7	22.8
125	22.5	
160	27.5	
200	27.0	28.8
250	29.3	
315	31.3	
400	31.8	32.7
500	33.7	
630	32.9	
800	30.0	29.9
1000	29.3	
1250	30.5	
1600	31.9	34.0
2000	34.9	
2500	36.4	
3150	37.3	37.5
4000	36.7	
5000	38.7	
6300+	40.8	42.4
8000+	42.2	
10000+	45.5	
Average 100-3150	30.4	

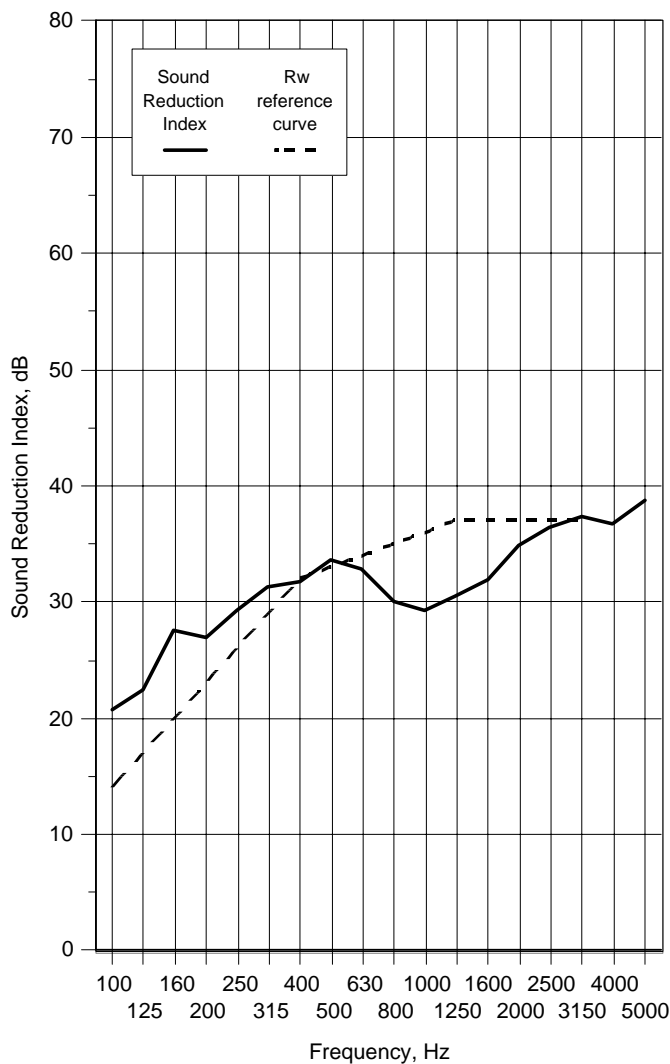

Rating according to BS EN ISO 717-1:1997

Rw(C;Ctr)= **33 (-1;-3)** dB

Notes * designates measurement corrected for background

designates limit of measurement due to background

+ designates frequency beyond standard and not UKAS accredited

v1.6

Test Number : 24 **Air temperature:** 16.8 °C
Client: Norsound Ltd **Air humidity:** 77 %
Test Date: 02/06/2008 **Receiving room volume:** 300 m3
Sample height: 2.115 m **Source room volume:** 115 m3
Sample width: 1.006 m **Sample weight:** 31.4 kg/m2
Product: Single leaf Strebord 54
Identification: Threshold=850 used with 650 threshold
 Head, hanging jamb & closing jamb=710

Freq f Hz	Sound Reduction Index, dB	
	1/3 Oct	1/1 Oct
50+	22.1	18.9
63+	17.7	
80+	18.1	
100	20.3	22.6
125	22.7	
160	27.5	
200	26.6	28.6
250	29.4	
315	31.1	
400	31.9	32.8
500	33.7	
630	32.9	
800	30.1	29.9
1000	29.3	
1250	30.4	
1600	31.9	34.0
2000	34.9	
2500	36.4	
3150	37.4	37.5
4000	36.6	
5000	38.6	
6300+	40.5	41.9
8000+	41.5	
10000+	44.6	
Average 100-3150	30.4	

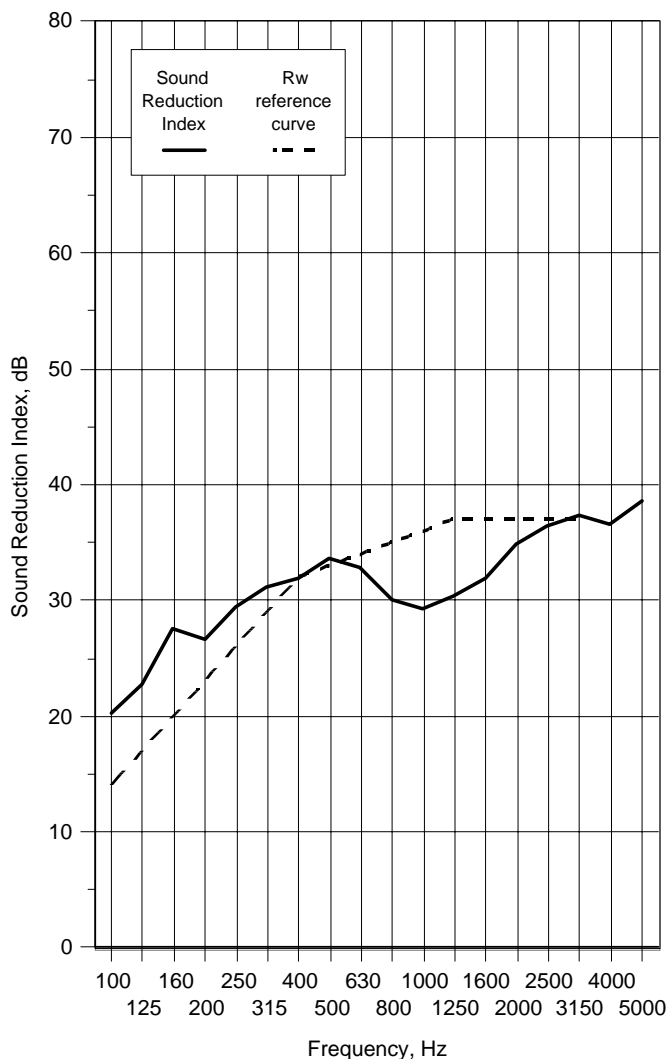

Rating according to BS EN ISO 717-1:1997

Rw(C;Ctr)= **33 (-1;-3)** dB

Notes * designates measurement corrected for background

designates limit of measurement due to background

+ designates frequency beyond standard and not UKAS accredited

v1.6

Test Number :	25	Air temperature:	16.9 °C
Client:	Norsound Ltd	Air humidity:	80 %
Test Date:	02/06/2008	Receiving room volume	300 m3
Sample height:	2.115 m	Source room volume:	115 m3
Sample width:	1.006 m	Sample weight:	29.3 kg/m2
Product	Single leaf Flamebreak 660		
Identification:	Fully caulked		

Freq f Hz	Sound Reduction Index, dB	
	1/3 Oct	1/1 Oct
50+	28.8	18.1
63+	25.2	
80+	13.7	
100	16.1	18.8
125	19.8	
160	23.7	
200	24.9	26.2
250	25.9	
315	28.6	
400	29.4	30.7
500	31.4	
630	31.7	
800	32.9	34.7
1000	34.8	
1250	37.7	
1600	39.4	40.8
2000	41.0	
2500	42.6	
3150	44.2	45.6
4000	45.9	
5000	47.4	
6300+	48.7	49.3
8000+	49.5	
10000+	49.6 *	
Average 100-3150	31.5	

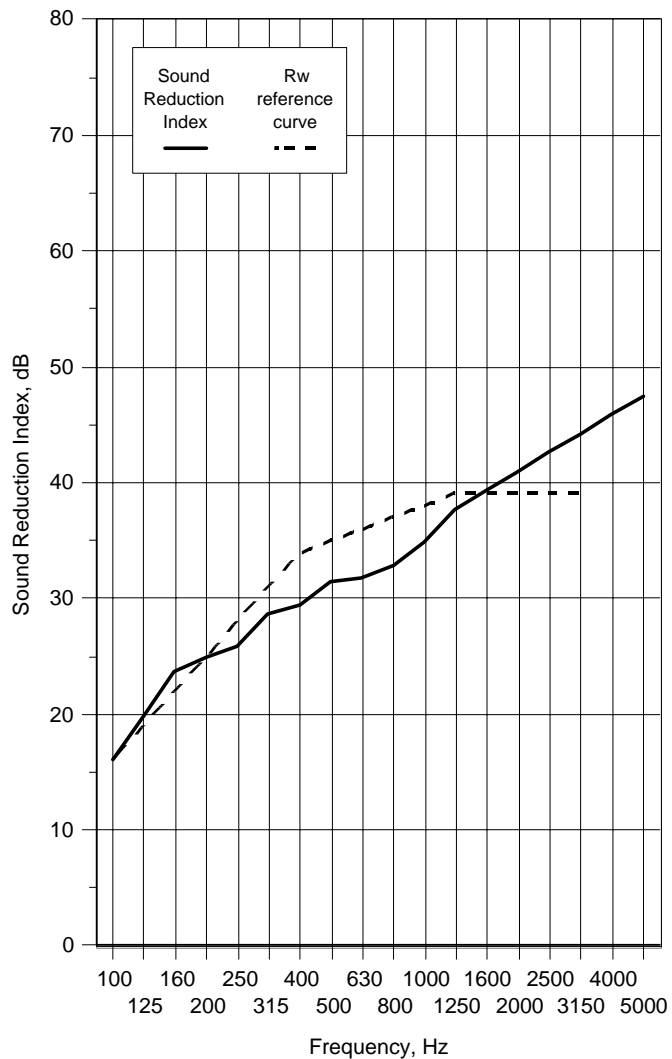

Rating according to BS EN ISO 717-1:1997

Rw(C;Ctr)= **35 (-1;-5)** dB

Notes * designates measurement corrected for background
 # designates limit of measurement due to background
 + designates frequency beyond standard and not UKAS accredited

v1.6

Test Number :	26	Air temperature:	16.9 °C
Client:	Norsound Ltd	Air humidity:	80 %
Test Date:	02/06/2008	Receiving room volume	300 m3
Sample height:	2.115 m	Source room volume:	115 m3
Sample width:	1.006 m	Sample weight:	29.3 kg/m2
Product	Single leaf Flamebreak 660		
Identification:	Threshold=850 used with 650 threshold Head, hanging jamb & closing jamb=710		

Freq f Hz	Sound Reduction Index, dB	
	1/3 Oct	1/1 Oct
50+	28.6	18.1
63+	23.7	
80+	13.9	
100	15.9	18.9
125	20.5	
160	24.2	
200	24.3	25.8
250	25.6	
315	28.2	
400	28.7	29.7
500	30.1	
630	30.4	
800	31.2	32.8
1000	33.1	
1250	34.9	
1600	35.1	36.5
2000	36.9	
2500	38.0	
3150	39.8	41.2
4000	41.5	
5000	42.7	
6300+	45.6	46.9
8000+	47.3	
10000+	48.1	
Average 100-3150	29.8	

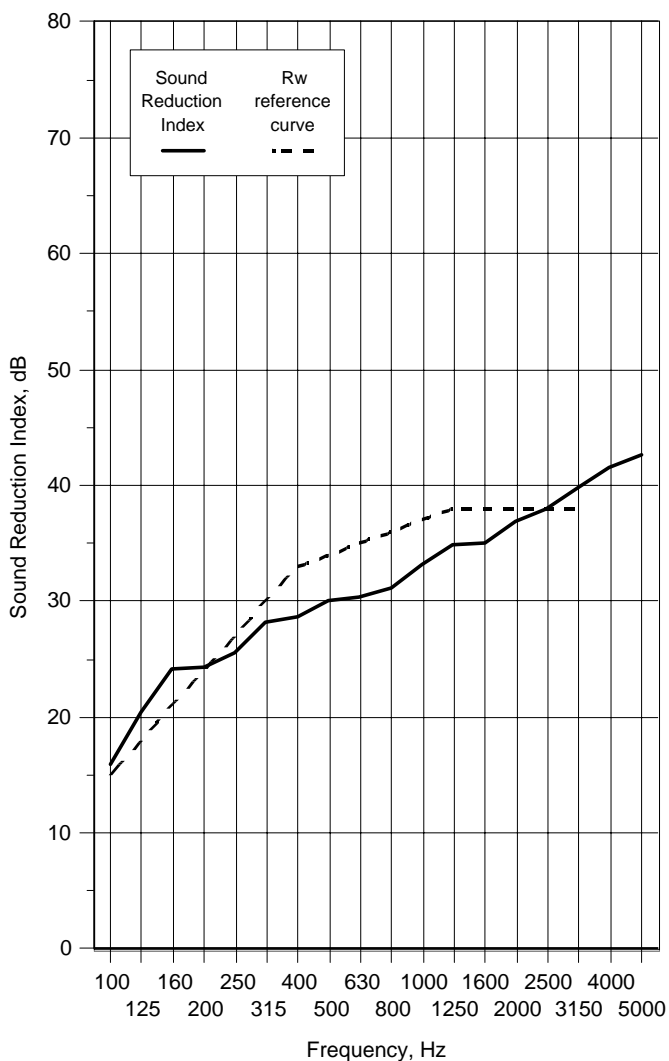

Rating according to BS EN ISO 717-1:1997

Rw(C;Ctr)= **34 (-2;-4) dB**

Notes * designates measurement corrected for background

designates limit of measurement due to background

+ designates frequency beyond standard and not UKAS accredited

v1.6

Test Number :	27	Air temperature:	16.9 °C
Client:	Norsound Ltd	Air humidity:	81 %
Test Date:	02/06/2008	Receiving room volume	300 m3
Sample height:	2.115 m	Source room volume:	115 m3
Sample width:	1.006 m	Sample weight:	29.3 kg/m2
Product	Single leaf Flamebreak 660		
Identification:	Threshold=810		
	Head, hanging jamb & closing jamb=710		

Freq f Hz	Sound Reduction Index, dB	
	1/3 Oct	1/1 Oct
50+	25.3	18.5
63+	19.5	
80+	15.5	
100	17.9	20.6
125	21.3	
160	26.1	26.9
200	26.0	
250	26.5	
315	28.6	
400	28.3	29.0
500	29.3	
630	29.4	
800	28.8	29.8
1000	29.6	
1250	31.3	
1600	32.8	34.6
2000	35.3	
2500	36.4	
3150	36.3	37.6
4000	37.6	
5000	39.5	
6300+	42.3	42.7
8000+	43.1	
10000+	42.7	
Average 100-3150	29.0	

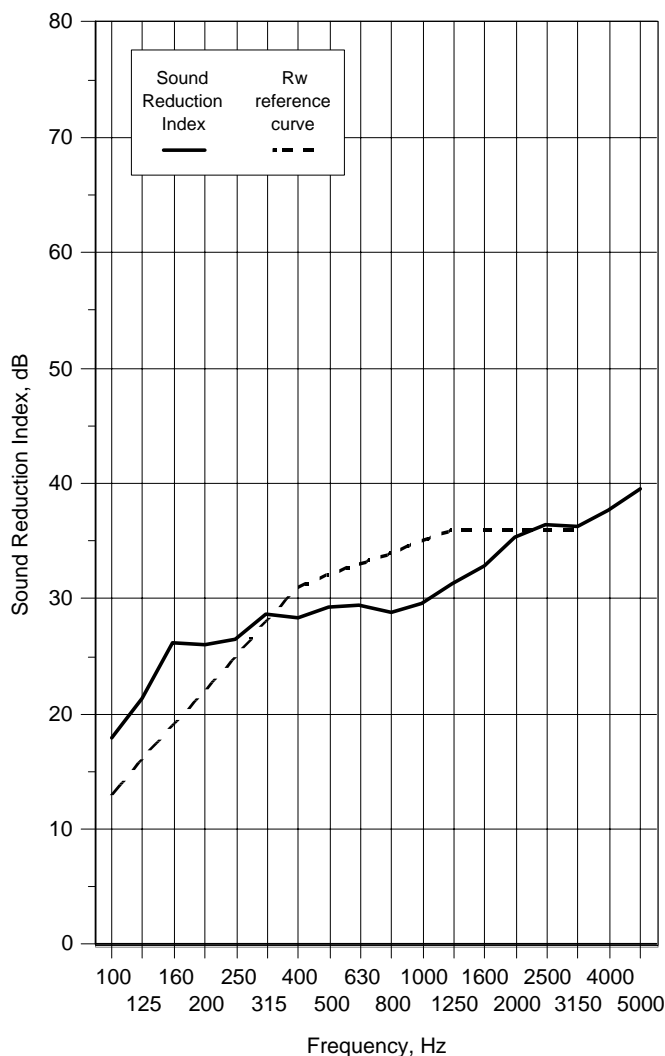

Rating according to BS EN ISO 717-1:1997

Rw(C;Ctr)= **32 (-1;-3) dB**

Notes * designates measurement corrected for background

designates limit of measurement due to background

+ designates frequency beyond standard and not UKAS accredited

v1.6

Test Number :	29	Air temperature:	16.3 °C
Client:	Norsound Ltd	Air humidity:	84 %
Test Date:	03/06/2008	Receiving room volume	300 m3
Sample height:	2.115 m	Source room volume:	115 m3
Sample width:	1.006 m	Sample weight:	35 kg/m2
Product	Single leaf Strebord 44+		
Identification:	Fully caulked		

Freq f Hz	Sound Reduction Index, dB	
	1/3 Oct	1/1 Oct
50+	24.2	21.4
63+	21.3	
80+	19.8	
100	23.0	25.0
125	24.7	
160	29.4	
200	29.2	30.7
250	30.9	
315	32.8	
400	33.0	33.9
500	34.4	
630	34.4	
800	31.9	31.6
1000	30.5	
1250	32.5	
1600	34.8	36.4
2000	36.8	
2500	38.6	
3150	40.3	39.9
4000	39.0	
5000	40.6	
6300+	43.4	44.8
8000+	44.5	
10000+	47.3	
Average 100-3150	32.3	

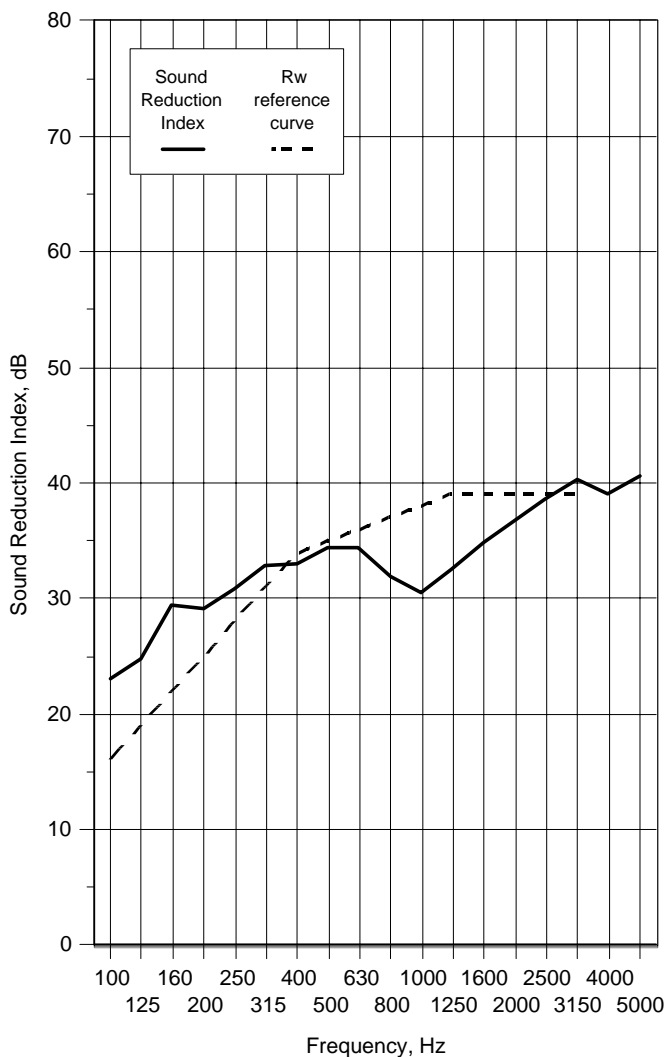

Rating according to BS EN ISO 717-1:1997

Rw(C;Ctr)= **35 (-1;-3)** dB

Notes * designates measurement corrected for background

designates limit of measurement due to background

+ designates frequency beyond standard and not UKAS accredited

vi.6

Test Number : 30
Client: Norsound Ltd
Test Date: 03/06/2008
Sample height: 2.115 m
Sample width: 1.006 m
Product Single leaf Strebord 54
Identification: Glazing=6mm Pyroshield (25% of door leaf area)
 Threshold=810
 Head, hanging jamb & closing jamb=710

Air temperature: 16.4 °C
Air humidity: 84 %
Receiving room volume 300 m3
Source room volume: 115 m3
Sample weight: 30.1 kg/m2

Freq f Hz	Sound Reduction Index, dB	
	1/3 Oct	1/1 Oct
50+	26.3	22.9
63+	26.2	
80+	19.7	25.0
100	22.8	
125	25.0	
160	29.3	30.8
200	29.7	
250	30.8	
315	32.2	
400	32.2	33.6
500	34.3	
630	34.7	
800	34.0	32.8
1000	32.9	
1250	31.8	
1600	30.8	32.4
2000	32.6	
2500	35.0	
3150	36.8	37.6
4000	37.4	
5000	38.8	
6300+	41.8	43.3
8000+	43.2	
10000+	45.5	
Average 100-3150	31.6	

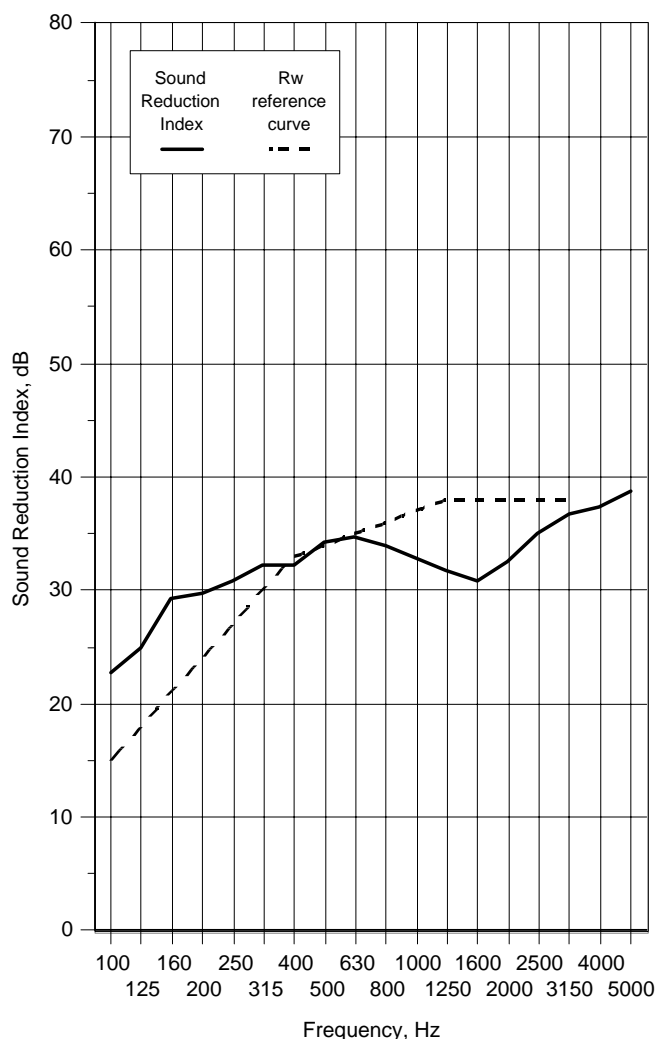

Rating according to BS EN ISO 717-1:1997

Rw(C;Ctr)= **34 (-1;-2)** dB

Notes * designates measurement corrected for background

designates limit of measurement due to background

+ designates frequency beyond standard and not UKAS accredited

v1.6

Test Number :	31	Air temperature:	16.4 °C
Client:	Norsound Ltd	Air humidity:	84 %
Test Date:	03/06/2008	Receiving room volume	300 m ³
Sample height:	2.115 m	Source room volume:	115 m ³
Sample width:	1.006 m	Sample weight:	30.1 kg/m ²
Product	Single leaf Strebord 54		
Identification:	Glazing=6mm Pyroshield (25% of door leaf area)		
	Threshold=810+650A		
	Head, hanging jamb & closing jamb=710		

Freq f Hz	Sound Reduction Index, dB	
	1/3 Oct	1/1 Oct
50+	24.4	23.1
63+	25.2	
80+	21.0	
100	23.6	25.3
125	24.7	
160	29.5	
200	30.0	30.9
250	30.7	
315	32.4	
400	32.2	33.9
500	34.7	
630	35.4	
800	34.6	33.3
1000	33.1	
1250	32.4	
1600	31.4	33.3
2000	33.4	
2500	36.3	
3150	38.5	39.0
4000	38.5	
5000	40.2	
6300+	43.2	44.6
8000+	44.4	
10000+	47.0	
Average 100-3150	32.1	

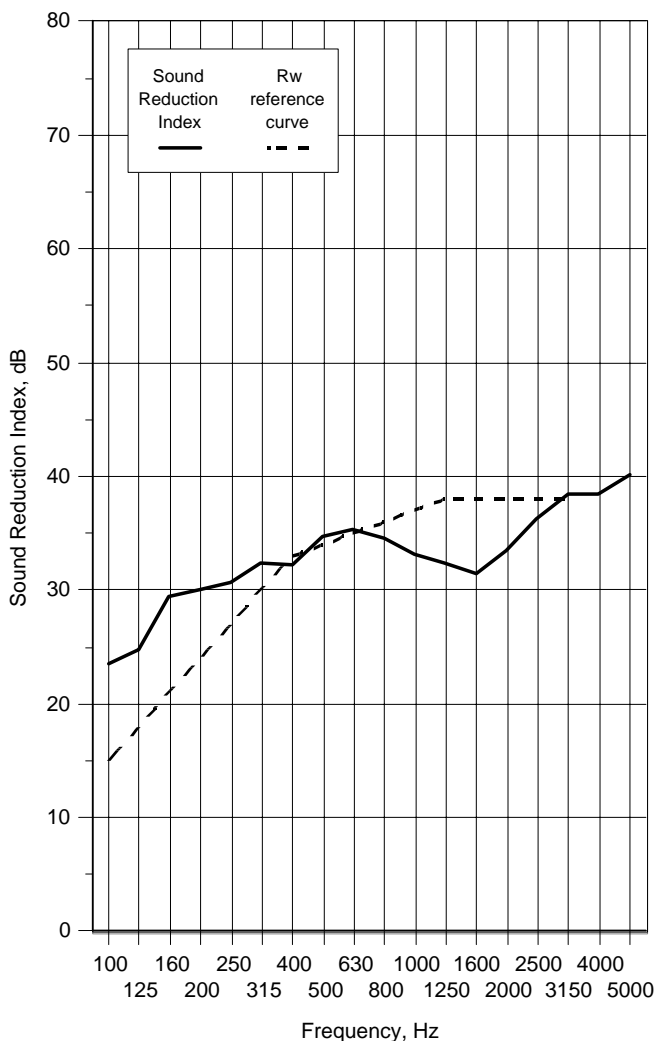

Rating according to BS EN ISO 717-1:1997

Rw(C;Ctr)= **34 (-1;-2)** dB

Notes * designates measurement corrected for background
 # designates limit of measurement due to background
 + designates frequency beyond standard and not UKAS accredited

v1.6

Test Number :	32	Air temperature:	16.4 °C
Client:	Norsound Ltd	Air humidity:	86 %
Test Date:	03/06/2008	Receiving room volume	300 m ³
Sample height:	2.115 m	Source room volume:	115 m ³
Sample width:	1.006 m	Sample weight:	30.1 kg/m ²
Product	Single leaf Strebord 54		
Identification:	Glazing=6mm Pyroshield (25% of door leaf area)		
	Threshold=810+650A		
	Head, hanging jamb & closing jamb=710		

Freq f Hz	Sound Reduction Index, dB	
	1/3 Oct	1/1 Oct
50+	25.0	23.7
63+	25.7	
80+	21.5	
100	24.8	25.7
125	24.4	
160	29.5	
200	29.6	30.9
250	30.9	
315	32.5	
400	32.2	33.9
500	34.8	
630	35.3	
800	34.8	33.5
1000	33.3	
1250	32.6	
1600	31.6	33.4
2000	33.5	
2500	36.5	
3150	38.6	39.2
4000	38.8	
5000	40.6	
6300+	43.6	45.0
8000+	44.8	
10000+	47.2	
Average 100-3150	32.2	

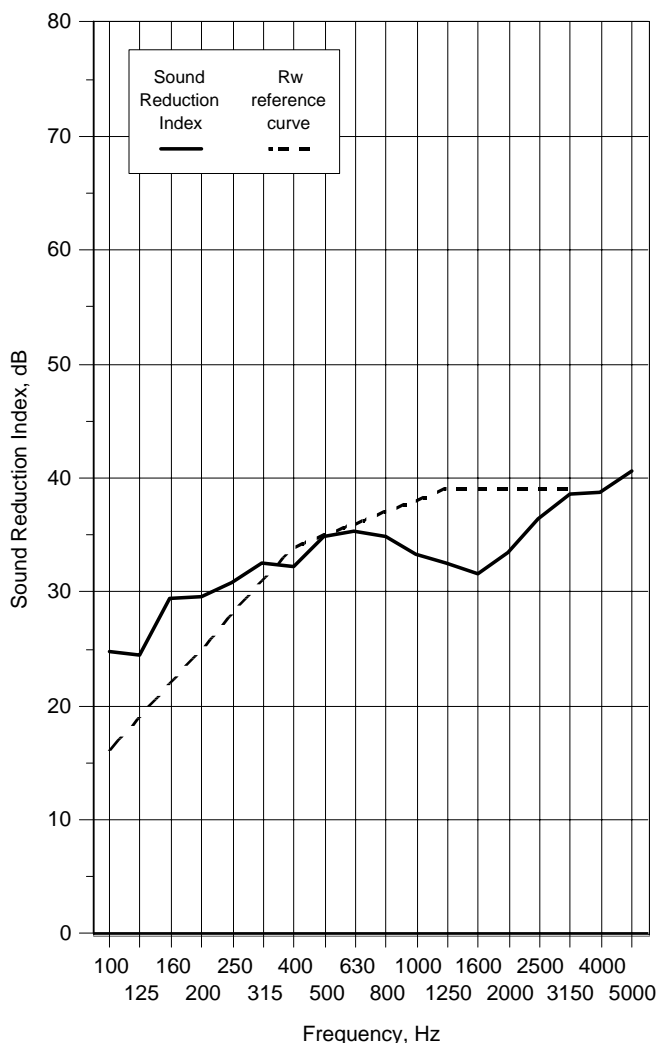

Rating according to BS EN ISO 717-1:1997

Rw(C;Ctr)= **35 (-1;-2)** dB

Notes * designates measurement corrected for background

designates limit of measurement due to background

+ designates frequency beyond standard and not UKAS accredited

v1.6

Test Number : 33 **Air temperature:** 16.4 °C
Client: Norsound Ltd **Air humidity:** 86 %
Test Date: 03/06/2008 **Receiving room volume** 300 m3
Sample height: 2.115 m **Source room volume:** 115 m3
Sample width: 1.006 m **Sample weight:** 24.3 kg/m2
Product Single leaf Flamebreak 660
Identification: Glazing=6mm Pyroshield (25% of door leaf area)
Threshold=810
Head, hanging jamb & closing jamb=710

Freq f Hz	Sound Reduction Index, dB	
	1/3 Oct	1/1 Oct
50+	22.2	19.8
63+	22.8	
80+	17.0	23.5
100	21.8	
125	23.0	
160	27.4	29.4
200	28.3	
250	29.2	
315	31.2	
400	29.8	31.0
500	31.8	
630	31.5	
800	31.3	32.0
1000	32.1	
1250	32.5	
1600	31.7	33.5
2000	33.7	
2500	36.4	
3150	38.2	
4000	39.6	39.4
5000	40.9	
6300+	43.2	
8000+	43.1	42.4
10000+	41.3	
Average 100-3150	30.6	

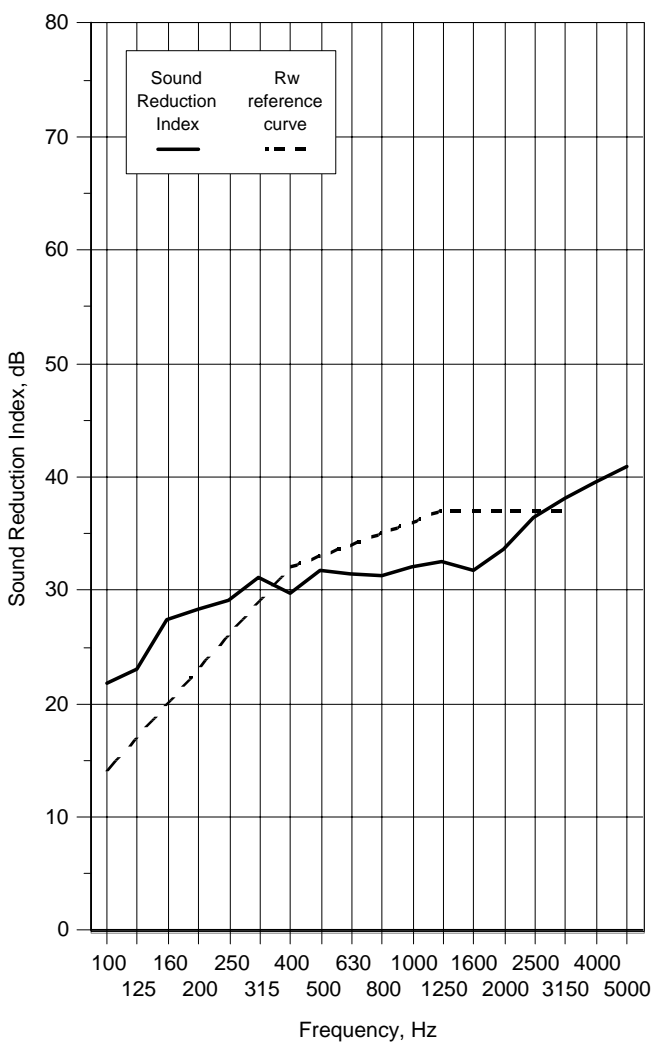

Rating according to BS EN ISO 717-1:1997

Rw(C;Ctr)= **33 (0;-2)** dB

Notes * designates measurement corrected for background

designates limit of measurement due to background

+ designates frequency beyond standard and not UKAS accredited

v1.6

Test Number :	34	Air temperature:	16.6 °C
Client:	Norsound Ltd	Air humidity:	83 %
Test Date:	03/06/2008	Receiving room volume	300 m3
Sample height:	2.115 m	Source room volume:	115 m3
Sample width:	1.006 m	Sample weight:	26.1 kg/m2
Product	Single leaf Flamebreak 660		
Identification:	Glazing=7mm Pyrobelite (25% of door leaf area)		
	Threshold=810		
	Head, hanging jamb & closing jamb=710		

Freq f Hz	Sound Reduction Index, dB	
	1/3 Oct	1/1 Oct
50+	22.3	19.9
63+	23.5	
80+	17.0	23.7
100	22.1	
125	23.1	
160	27.7	29.5
200	28.4	
250	29.5	
315	31.1	
400	30.4	31.5
500	32.5	
630	31.8	
800	31.6	32.0
1000	31.9	
1250	32.7	
1600	33.1	
2000	36.0	35.3
2500	38.1	
3150	39.2	40.3
4000	40.2	
5000	41.9	
6300+	44.4	43.7
8000+	44.1	
10000+	42.7	
Average 100-3150	31.2	

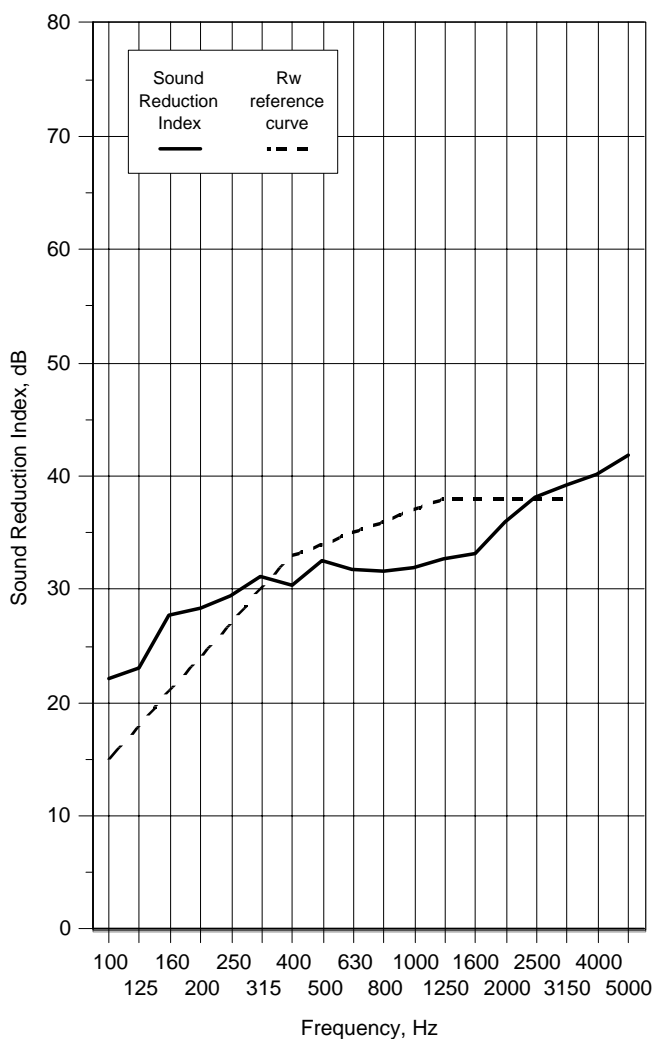

Rating according to BS EN ISO 717-1:1997

Rw(C;Ctr)= **34 (-1;-3)** dB

Notes * designates measurement corrected for background

designates limit of measurement due to background

+ designates frequency beyond standard and not UKAS accredited

v1.6

Test Number : 35
Client: Norsound Ltd
Test Date: 03/06/2008
Sample height: 2.115 m
Sample width: 1.006 m
Product Single leaf Flamebreak 660
Identification: Glazing=12mm Pyrobelite (25% of door leaf area)
 Threshold=810
 Head, hanging jamb & closing jamb=710

Air temperature: 16.6 °C
Air humidity: 83 %
Receiving room volume 300 m3
Source room volume: 115 m3
Sample weight: 31.3 kg/m2

Freq f Hz	Sound Reduction Index, dB	
	1/3 Oct	1/1 Oct
50+	24.0	21.1
63+	24.9	
80+	18.0	
100	22.4	24.1
125	23.8	
160	27.9	
200	28.9	
250	29.7	29.8
315	31.1	
400	30.1	
500	31.7	30.9
630	31.0	
800	30.6	31.2
1000	30.8	
1250	32.3	
1600	34.5	
2000	37.5	
2500	38.9	36.6
3150	38.7	
4000	39.1	
5000	40.2	39.3
6300+	43.0	
8000+	42.7	
10000+	41.3	42.3
Average 100-3150	31.2	

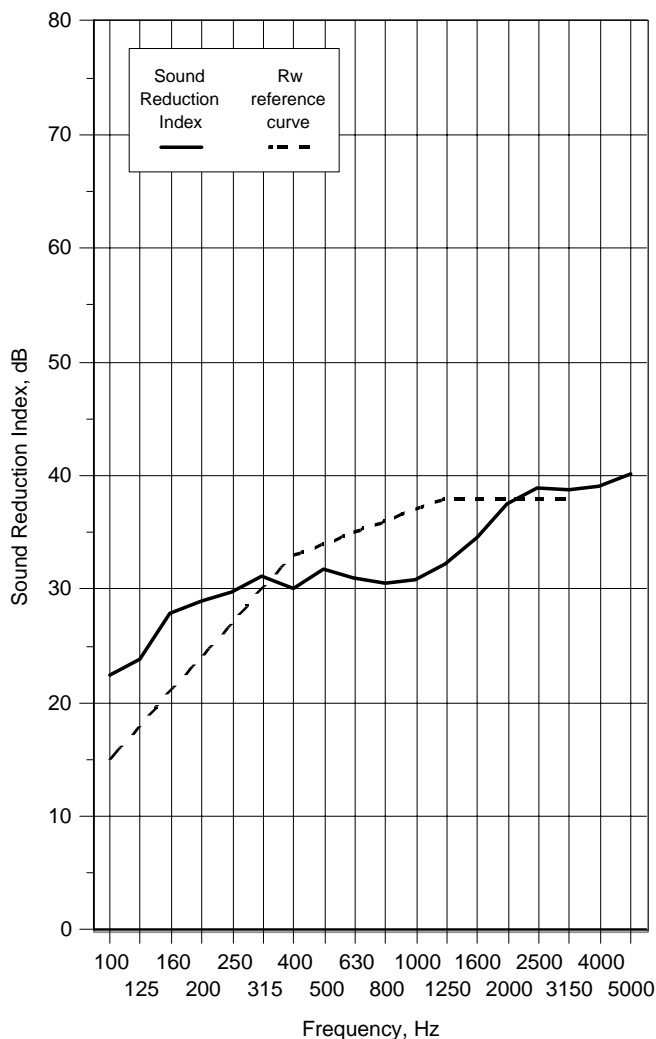

Rating according to BS EN ISO 717-1:1997

Rw(C;Ctr)= **34 (-1;-3) dB**

Notes * designates measurement corrected for background

designates limit of measurement due to background

+ designates frequency beyond standard and not UKAS accredited

v1.6

Test Number :	36	Air temperature:	16.6 °C
Client:	Norsound Ltd	Air humidity:	83 %
Test Date:	03/06/2008	Receiving room volume	300 m ³
Sample height:	2.115 m	Source room volume:	115 m ³
Sample width:	1.006 m	Sample weight:	31.3 kg/m ²
Product	Single leaf Flamebreak 660		
Identification:	Glazing=12mm Pyrobelite (25% of door leaf area)		
	Threshold=810		
	Head, hanging jamb & closing jamb=710		

Freq f Hz	Sound Reduction Index, dB	
	1/3 Oct	1/1 Oct
50+	23.8	21.1
63+	24.6	
80+	18.1	
100	22.1	24.2
125	24.1	
160	28.4	
200	29.1	29.9
250	29.7	
315	31.1	
400	30.2	30.8
500	31.5	
630	30.9	
800	30.7	31.3
1000	30.9	
1250	32.5	
1600	34.5	36.6
2000	37.6	
2500	39.0	
3150	38.7	39.2
4000	38.9	
5000	40.1	
6300+	42.7	42.0
8000+	42.4	
10000+	41.1	
Average 100-3150	31.3	

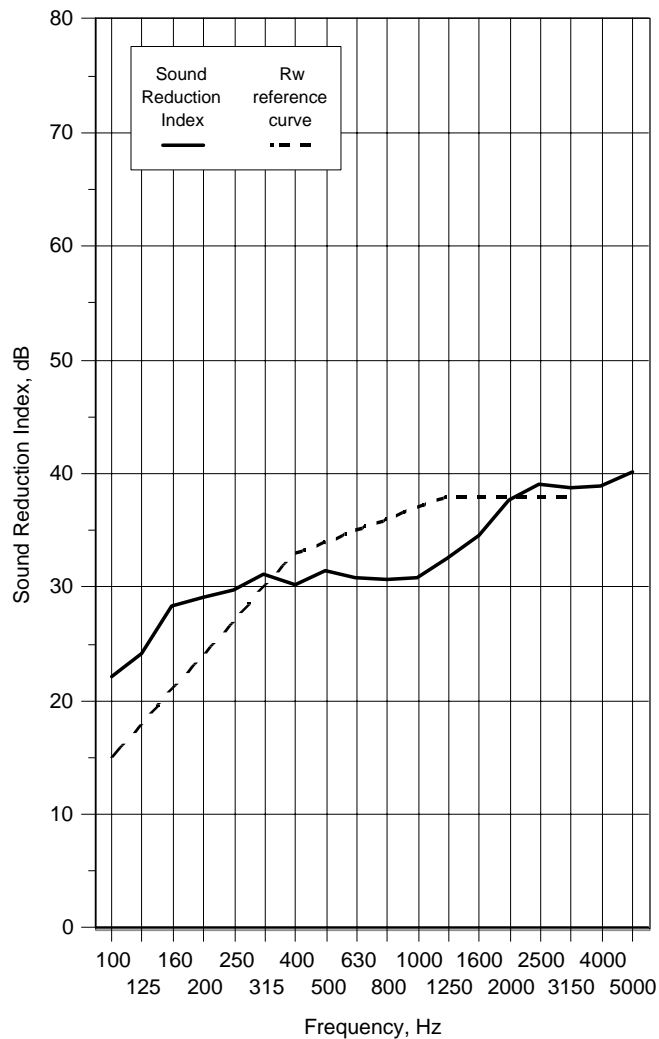

Rating according to BS EN ISO 717-1:1997

Rw(C;Ctr)= **34 (-1;-3) dB**

Notes * designates measurement corrected for background
 # designates limit of measurement due to background
 + designates frequency beyond standard and not UKAS accredited

v1.6

Test Number :	37	Air temperature:	16.7 °C
Client:	Norsound Ltd	Air humidity:	83 %
Test Date:	03/06/2008	Receiving room volume	300 m3
Sample height:	2.115 m	Source room volume:	115 m3
Sample width:	1.006 m	Sample weight:	37.1 kg/m2
Product	Single leaf Strebord 54		
Identification:	Glazing=16mm Pyrobelite (25% of door leaf area)		
	Threshold=810		
	Head, hanging jamb & closing jamb=710		

Freq f Hz	Sound Reduction Index, dB	
	1/3 Oct	1/1 Oct
50+	23.5	23.3
63+	25.5	
80+	21.6	
100	25.2	26.7
125	25.9	
160	30.7	
200	30.2	31.6
250	32.0	
315	33.3	
400	33.0	33.6
500	34.6	
630	33.3	
800	31.6	32.2
1000	31.7	
1250	33.8	
1600	34.9	36.8
2000	37.7	
2500	38.7	
3150	38.7	38.8
4000	37.9	
5000	40.1	
6300+	43.5	44.5
8000+	44.2	
10000+	46.4	
Average 100-3150	32.8	

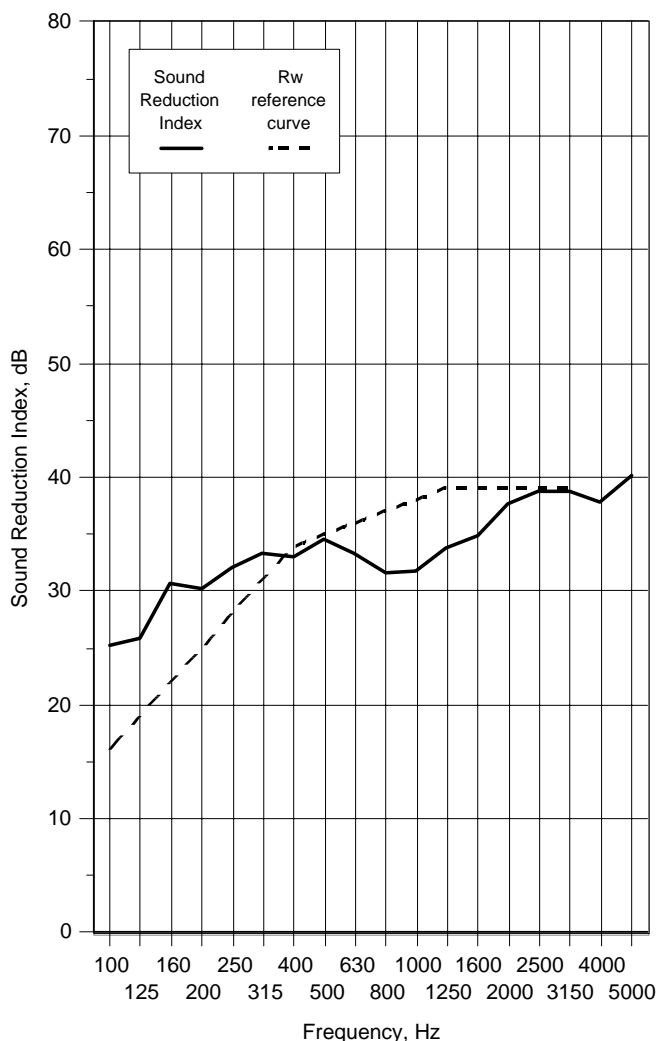

Rating according to BS EN ISO 717-1:1997

Rw(C;Ctr)= **35 (-1;-2)** dB

Notes * designates measurement corrected for background

designates limit of measurement due to background

+ designates frequency beyond standard and not UKAS accredited

v1.6

Test Number : 38 **Air temperature:** 16.7 °C
Client: Norsound Ltd **Air humidity:** 83 %
Test Date: 03/06/2008 **Receiving room volume** 300 m3
Sample height: 2.115 m **Source room volume:** 115 m3
Sample width: 1.006 m **Sample weight:** 27.2 kg/m2
Product Single leaf Flamebreak 660
Identification: Glazing=11.5 3Ply PA Res Glass (25% of door leaf area)
 Threshold=810
 Head, hanging jamb & closing jamb=710

Freq f Hz	Sound Reduction Index, dB	
	1/3 Oct	1/1 Oct
50+	22.2	20.6
63+	24.3	
80+	17.8	
100	22.5	24.1
125	23.4	
160	28.2	
200	28.8	
250	29.4	29.6
315	30.8	
400	30.1	
500	32.0	31.0
630	31.2	
800	31.4	
1000	31.8	31.9
1250	32.6	
1600	34.7	
2000	37.6	36.6
2500	38.3	
3150	38.3	
4000	40.6	40.1
5000	42.2	
6300+	44.6	
8000+	43.9	44.0
10000+	43.4	
Average 100-3150	31.3	

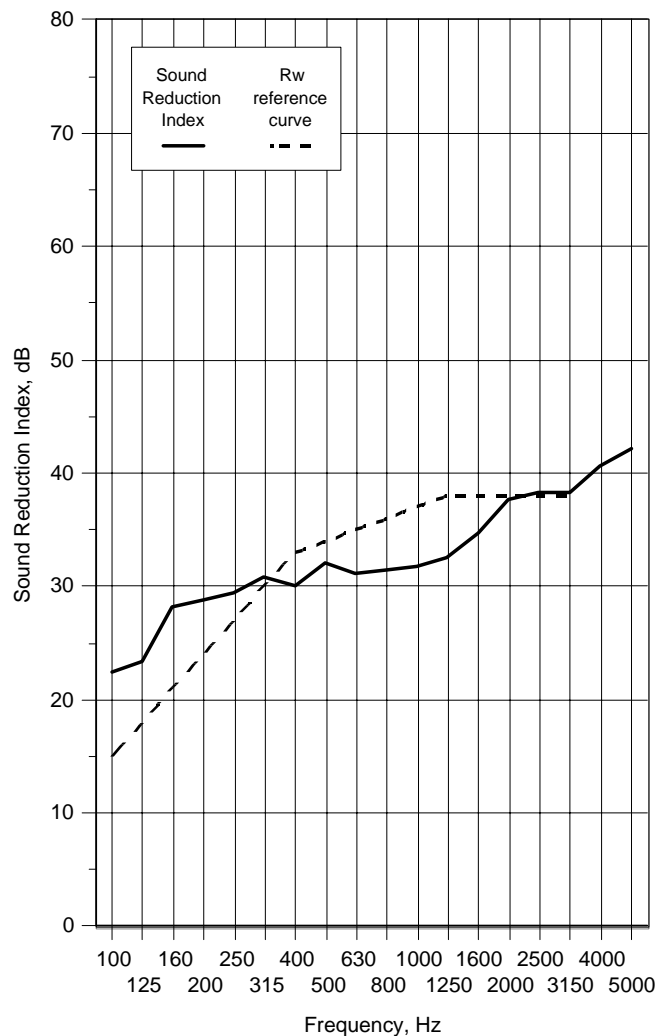

Rating according to BS EN ISO 717-1:1997

Rw(C;Ctr)= **34 (-1;-2)** dB

Notes * designates measurement corrected for background

designates limit of measurement due to background

+ designates frequency beyond standard and not UKAS accredited

v1.6

Test Number :	39	Air temperature:	16.7 °C
Client:	Norsound Ltd	Air humidity:	83 %
Test Date:	03/06/2008	Receiving room volume	300 m ³
Sample height:	2.115 m	Source room volume:	115 m ³
Sample width:	1.006 m	Sample weight:	24.3 kg/m ²
Product	Single leaf Flamebreak 660		
Identification:	Glazing=6mm Pyroshield (25% of door leaf area)		
	Threshold=810		
	Head, hanging jamb & closing jamb=710		

Freq f Hz	Sound Reduction Index, dB	
	1/3 Oct	1/1 Oct
50+	23.2	20.2
63+	23.3	
80+	17.1	23.4
100	21.8	
125	22.8	
160	27.6	29.7
200	28.5	
250	29.7	
315	31.1	31.1
400	29.9	
500	31.7	
630	31.8	32.0
800	31.6	
1000	32.1	
1250	32.4	33.4
1600	31.5	
2000	33.7	
2500	36.0	39.7
3150	37.6	
4000	40.3	
5000	42.3	43.7
6300+	45.0	
8000+	44.1	
10000+	42.4	
Average 100-3150	30.6	

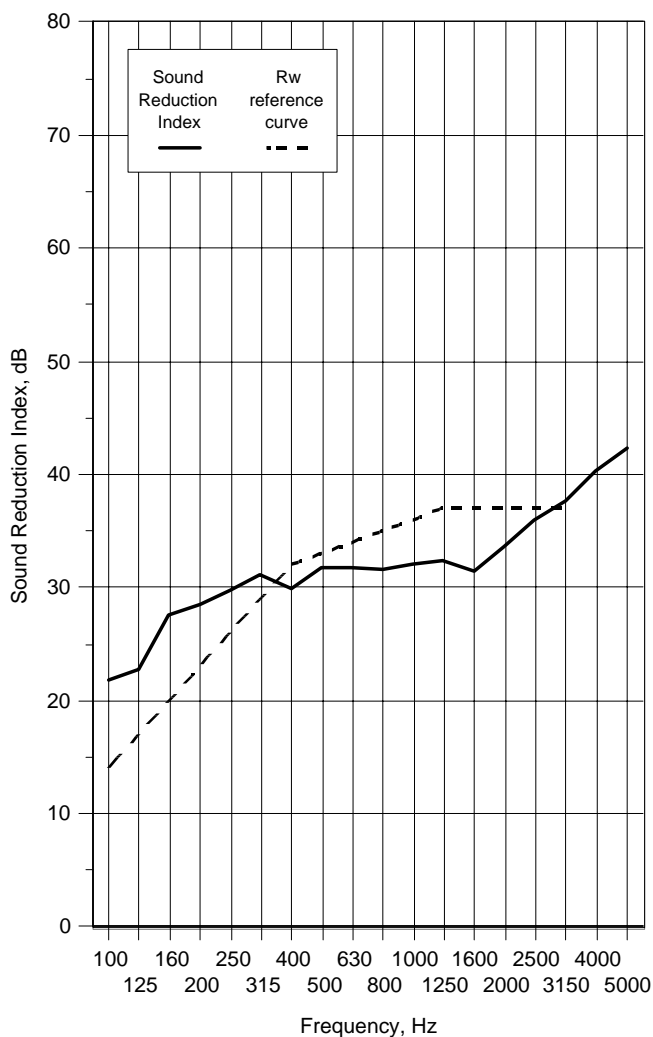

Rating according to BS EN ISO 717-1:1997

Rw(C;Ctr)= **33 (-1;-2)** dB

Notes * designates measurement corrected for background
 # designates limit of measurement due to background
 + designates frequency beyond standard and not UKAS accredited

v1.6

Test Number :	41	Air temperature:	16.7 °C
Client:	Norsound Ltd	Air humidity:	83 %
Test Date:	03/06/2008	Receiving room volume	300 m ³
Sample height:	2.115 m	Source room volume:	115 m ³
Sample width:	1.006 m	Sample weight:	37.1 kg/m ²
Product	Single leaf Strebord 54		
Identification:	Glazing=12mm Pyrobelite (25% of door leaf area)		
	Threshold=810		
	Head, hanging jamb & closing jamb=710		

Freq f Hz	Sound Reduction Index, dB	
	1/3 Oct	1/1 Oct
50+	25.5	24.0
63+	25.6	
80+	22.0	26.5
100	24.7	
125	26.3	
160	29.9	31.4
200	30.2	
250	31.8	
315	32.6	
400	32.4	33.2
500	34.1	
630	33.4	
800	31.4	31.7
1000	31.1	
1250	33.1	
1600	34.8	
2000	37.6	36.7
2500	38.5	
3150	37.6	37.9
4000	37.2	
5000	39.2	
6300+	41.9	42.1
8000+	41.8	
10000+	42.6	
Average 100-3150	32.5	

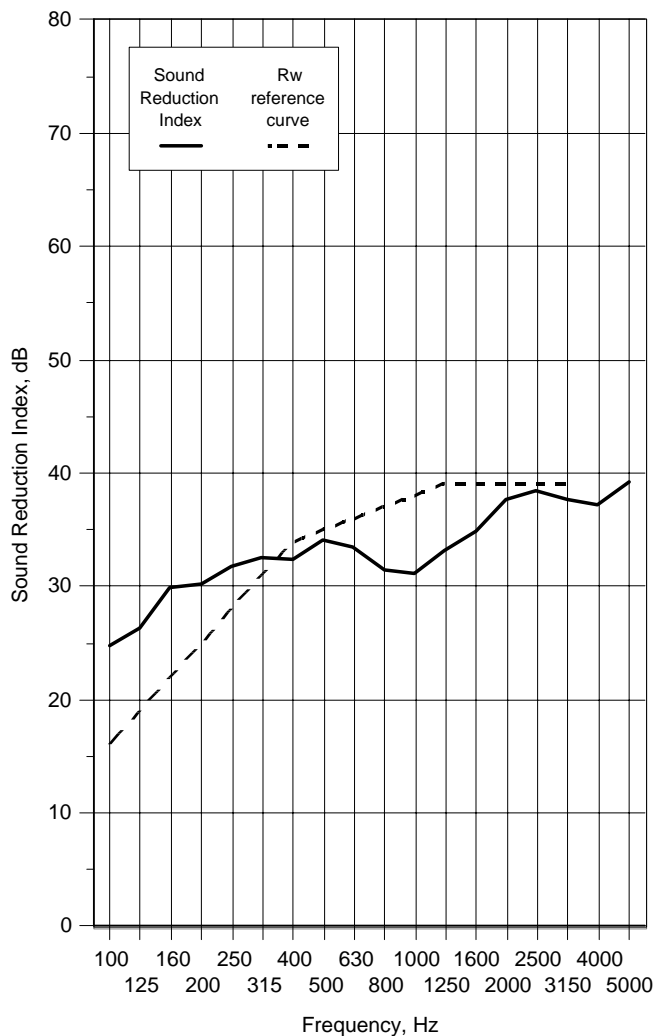

Rating according to BS EN ISO 717-1:1997

Rw(C;Ctr)= **35 (-1;-3) dB**

Notes * designates measurement corrected for background
 # designates limit of measurement due to background
 + designates frequency beyond standard and not UKAS accredited

v1.6

Test Number : 42
Client: Norsound Ltd
Test Date: 03/06/2008
Sample height: 2.155 m
Sample width: 1.006 m
Product Single leaf Strebord 54
Identification: Glazing=7mm Pyrobelite (25% of door leaf area)
 Threshold=810
 Head, hanging jamb & closing jamb=710

Air temperature: 16.7 °C
Air humidity: 83 %
Receiving room volume 300 m³
Source room volume: 115 m³
Sample weight: 30.3 kg/m²

Freq f Hz	Sound Reduction Index, dB	
	1/3 Oct	1/1 Oct
50+	24.0	21.9
63+	23.5	
80+	19.7	
100	23.0	25.0
125	24.8	
160	29.1	
200	29.3	30.7
250	30.9	
315	32.6	
400	32.0	33.5
500	34.2	
630	34.8	
800	33.9	32.8
1000	32.2	
1250	32.4	
1600	32.9	34.8
2000	35.5	
2500	37.3	
3150	37.8	38.5
4000	38.1	
5000	39.8	
6300+	42.9	43.7
8000+	43.5	
10000+	44.8	
Average 100-3150	32.0	

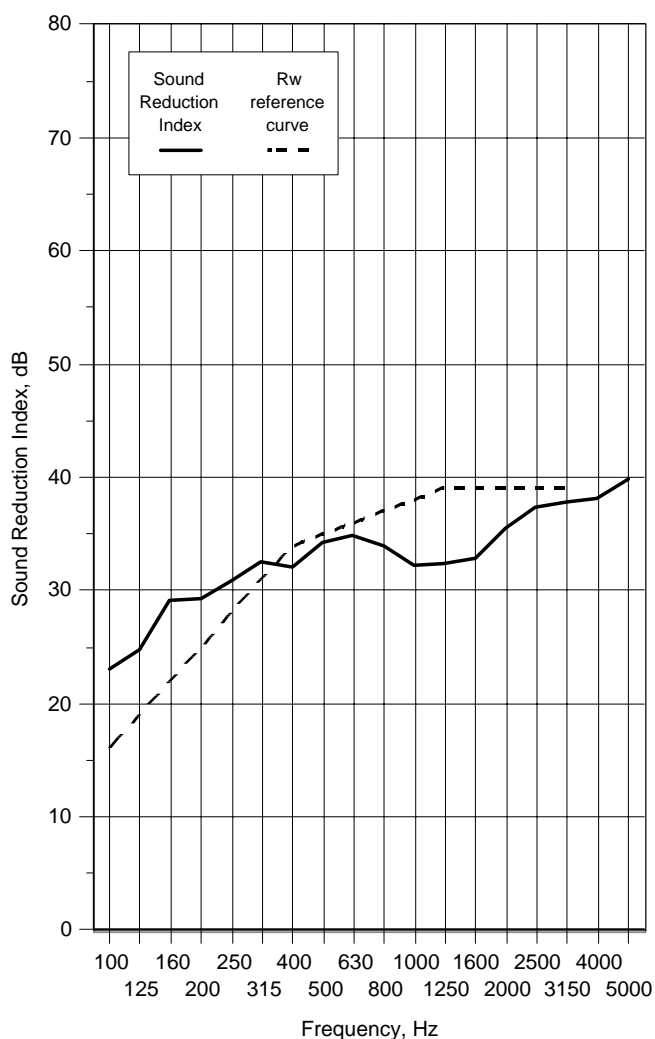

Rating according to BS EN ISO 717-1:1997

Rw(C;Ctr)= **35 (-1;-3)** dB

Notes * designates measurement corrected for background

designates limit of measurement due to background

+ designates frequency beyond standard and not UKAS accredited

v1.6

Test Number : 44 **Air temperature:** 15.5 °C
Client: Norsound Ltd **Air humidity:** 77 %
Test Date: 04/06/2008 **Receiving room volume:** 300 m3
Sample height: 2.115 m **Source room volume:** 115 m3
Sample width: 1.006 m **Sample weight:** 27.8 kg/m2
Product: Single leaf Strebord 44
Identification: Glazing=11.5 3Ply PA Res Glass (25% of door leaf area)
 Threshold=810
 Head, hanging jamb & closing jamb=710

Freq f Hz	Sound Reduction Index, dB	
	1/3 Oct	1/1 Oct
50+	25.3	23.8
63+	27.1	
80+	21.2	
100	23.2	25.1
125	24.7	
160	29.8	
200	29.9	31.1
250	31.3	
315	32.5	
400	32.5	33.6
500	34.3	
630	34.2	
800	32.9	31.3
1000	30.8	
1250	30.5	
1600	32.5	34.4
2000	35.0	
2500	36.7	
3150	38.7	39.1
4000	39.9	
5000	38.7	
6300+	40.6	41.5
8000+	41.1	
10000+	43.4	
Average 100-3150	31.8	

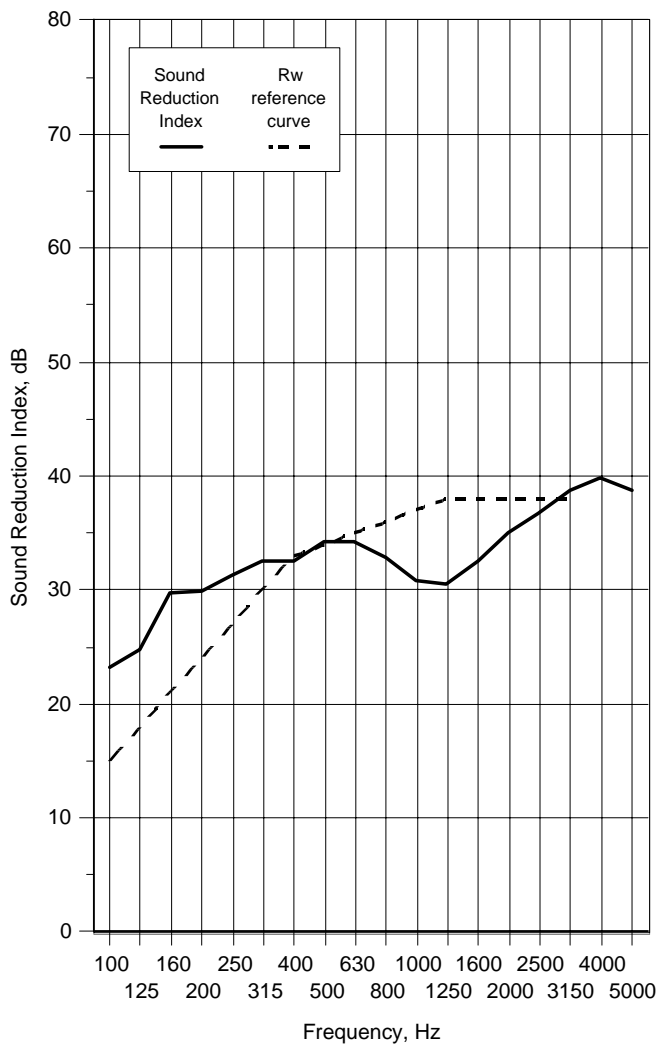

Rating according to BS EN ISO 717-1:1997

Rw(C;Ctr)= **34 (-1;-2) dB**

Notes * designates measurement corrected for background
 # designates limit of measurement due to background
 + designates frequency beyond standard and not UKAS accredited

v1.6

Test Number : 45
Client: Norsound Ltd
Test Date: 04/06/2008
Sample height: 2.115 m
Sample width: 1.006 m
Product Single leaf Strebord 44
Identification: Glazing=12mm Pyrobelite (25% of door leaf area)
 Threshold=810
 Head, hanging jamb & closing jamb=710

Air temperature: 15.7 °C
Air humidity: 78 %
Receiving room volume 300 m³
Source room volume: 115 m³
Sample weight: 27.8 kg/m²

Freq f Hz	Sound Reduction Index, dB	
	1/3 Oct	1/1 Oct
50+	24.8	23.0
63+	26.6	
80+	20.1	
100	22.7	25.0
125	24.9	
160	29.9	
200	29.6	30.8
250	31.3	
315	31.9	
400	31.9	32.8
500	33.6	
630	33.2	
800	32.0	30.7
1000	29.9	
1250	30.5	
1600	33.1	35.0
2000	35.7	
2500	37.0	
3150	39.2	39.5
4000	40.4	
5000	39.1	
6300+	40.5	41.6
8000+	41.3	
10000+	43.7	
Average 100-3150	31.7	

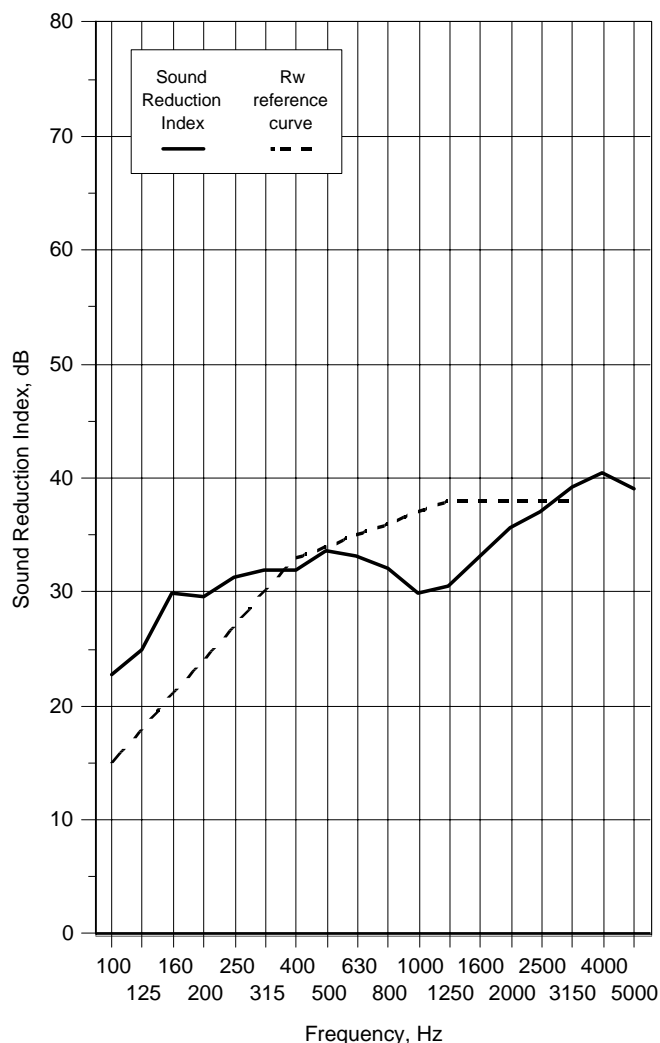

Rating according to BS EN ISO 717-1:1997

Rw(C;Ctr)= **34 (-1;-3) dB**

Notes * designates measurement corrected for background

designates limit of measurement due to background

+ designates frequency beyond standard and not UKAS accredited

v1.6

Test Number : 46 **Air temperature:** 15.9 °C
Client: Norsound Ltd **Air humidity:** 77 %
Test Date: 04/06/2008 **Receiving room volume:** 300 m3
Sample height: 2.115 m **Source room volume:** 115 m3
Sample width: 1.006 m **Sample weight:** 27.8 kg/m2
Product: Single leaf Strebord 44
Identification: Glazing=12mm Pyrobelite (25% of door leaf area)
 Threshold=810+650
 Head, hanging jamb & closing jamb=710

Freq f Hz	Sound Reduction Index, dB	
	1/3 Oct	1/1 Oct
50+	24.1	23.8
63+	25.5	
80+	22.4	
100	24.4	26.1
125	25.6	
160	30.1	
200	30.3	31.4
250	31.7	
315	32.4	
400	32.2	
500	34.5	33.6
630	34.6	
800	33.0	
1000	30.2	31.3
1250	31.0	
1600	33.5	
2000	36.2	35.4
2500	37.4	
3150	39.7	
4000	41.5	40.4
5000	40.0	
6300+	41.4	
8000+	42.3	42.7
10000+	45.7	
Average 100-3150	32.3	

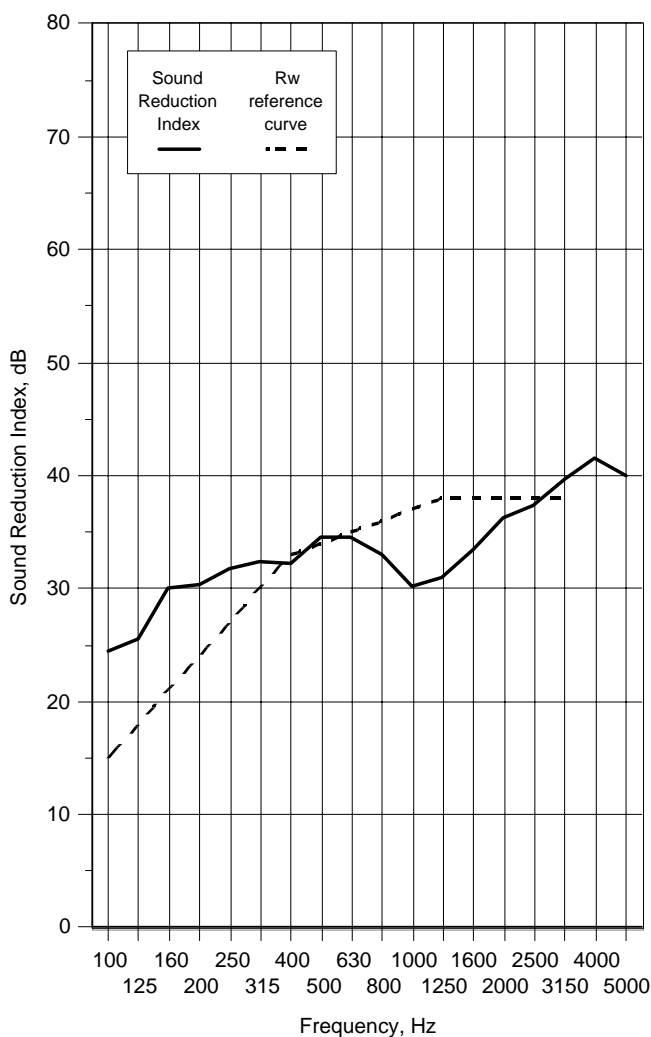

Rating according to BS EN ISO 717-1:1997

Rw(C;Ctr)= **34 (-1;-2)** dB

Notes * designates measurement corrected for background

designates limit of measurement due to background

+ designates frequency beyond standard and not UKAS accredited

v1.6

Test Number :	47	Air temperature:	15.9 °C
Client:	Norsound Ltd	Air humidity:	77 %
Test Date:	04/06/2008	Receiving room volume	300 m3
Sample height:	2.115 m	Source room volume:	115 m3
Sample width:	1.006 m	Sample weight:	27.8 kg/m2
Product	Single leaf Strebord 44		
Identification:	Glazing=12mm Pyrobelite (25% of door leaf area)		
	Threshold=810+650		
	Head, hanging jamb & closing jamb=710		

Freq f Hz	Sound Reduction Index, dB	
	1/3 Oct	1/1 Oct
50+	25.1	24.3
63+	25.9	
80+	22.7	
100	24.2	25.9
125	25.4	
160	30.3	
200	30.1	31.3
250	31.6	
315	32.5	
400	32.3	33.7
500	34.5	
630	34.6	
800	33.1	31.3
1000	30.3	
1250	30.9	
1600	33.5	35.4
2000	36.2	
2500	37.5	
3150	39.7	40.3
4000	41.5	
5000	39.9	
6300+	41.6	42.8
8000+	42.4	
10000+	45.3	
Average 100-3150	32.3	

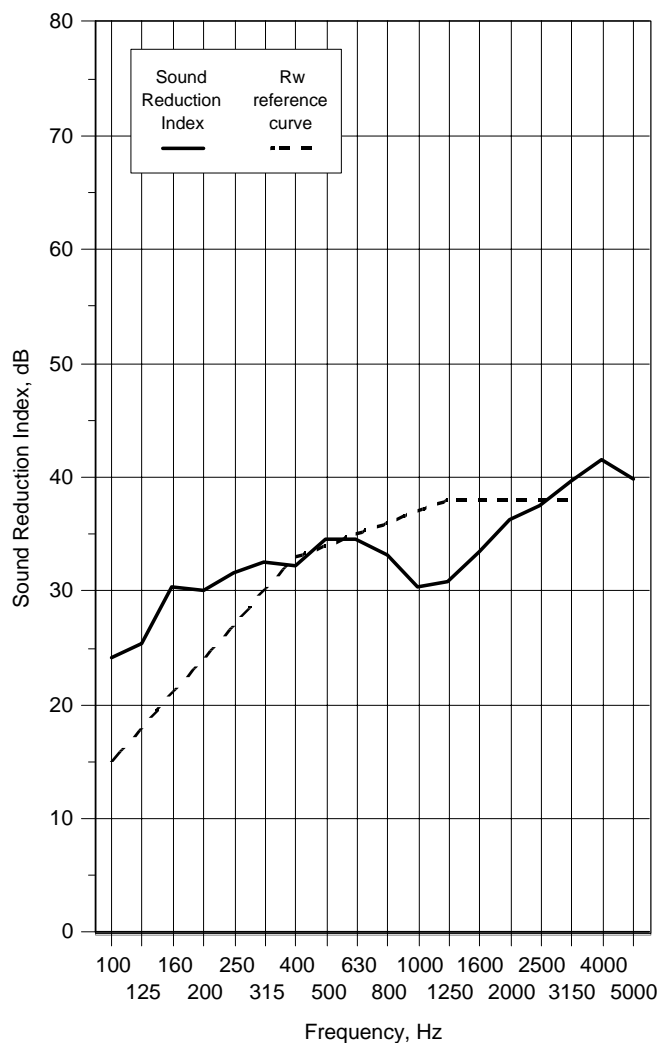

Rating according to BS EN ISO 717-1:1997

Rw(C;Ctr)= **34 (-1;-2) dB**

Notes * designates measurement corrected for background

designates limit of measurement due to background

+ designates frequency beyond standard and not UKAS accredited

v1.6

Test Number : 48 **Air temperature:** 15.9 °C
Client: Norsound Ltd **Air humidity:** 77 %
Test Date: 04/06/2008 **Receiving room volume** 300 m3
Sample height: 2.115 m **Source room volume:** 115 m3
Sample width: 1.006 m **Sample weight:** 20.8 kg/m2
Product Single leaf Flamebreak 430
Identification: Glazing=12mm Pyrobelite (25% of door leaf area)
Threshold=810
Head, hanging jamb & closing jamb=710

Freq f Hz	Sound Reduction Index, dB	
	1/3 Oct	1/1 Oct
50+	23.8	22.1
63+	22.6	
80+	20.7	
100	22.6	24.1
125	23.4	
160	27.9	
200	28.4	29.1
250	28.9	
315	30.0	
400	27.4	28.5
500	29.2	
630	29.1	
800	28.8	29.5
1000	29.4	
1250	30.6	
1600	33.5	35.2
2000	35.8	
2500	36.9	
3150	38.4	39.1
4000	38.6	
5000	40.6	
6300+	42.7	42.8
8000+	42.2	
10000+	43.5	
Average 100-3150	30.0	

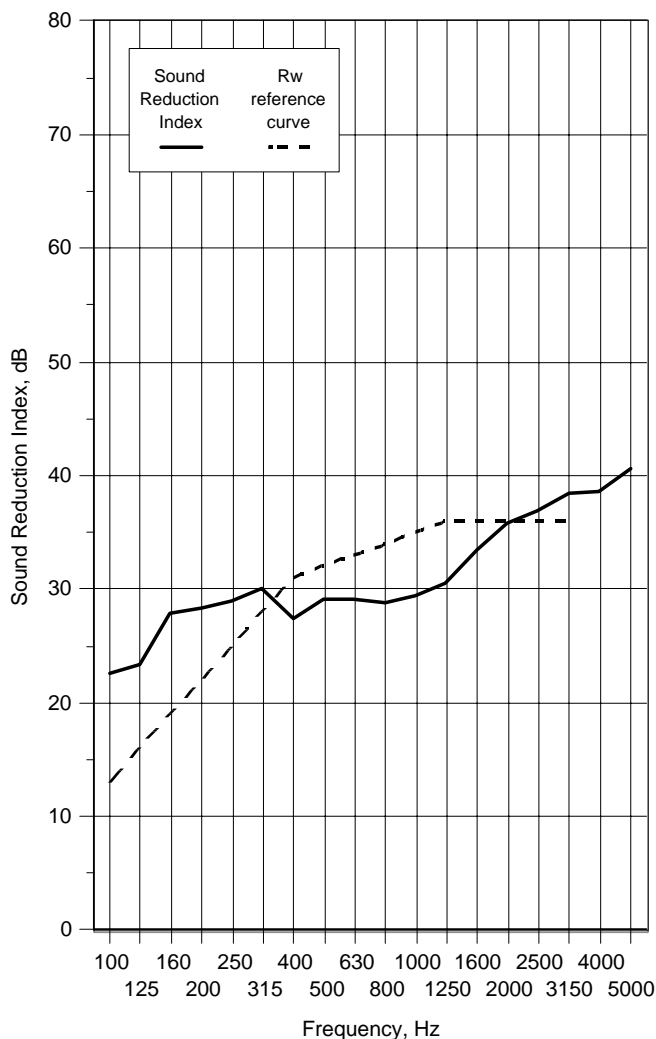

Rating according to BS EN ISO 717-1:1997

Rw(C;Ctr)= **32 (-1;-2)** dB

Notes * designates measurement corrected for background
 # designates limit of measurement due to background
 + designates frequency beyond standard and not UKAS accredited

v1.6

Test Number :	49	Air temperature:	16 °C
Client:	Norsound Ltd	Air humidity:	77 %
Test Date:	04/06/2008	Receiving room volume	300 m3
Sample height:	2.115 m	Source room volume:	115 m3
Sample width:	1.006 m	Sample weight:	18.4 kg/m2
Product	Single leaf Flamebreak 430		
Identification:	Glazing=6mm Pyroshield (25% of door leaf area)		
	Threshold=810		
	Head, hanging jamb & closing jamb=710		

Freq f Hz	Sound Reduction Index, dB	
	1/3 Oct	1/1 Oct
50+	21.6	19.8
63+	21.3	
80+	17.7	
100	20.0	21.8
125	21.5	
160	26.0	
200	27.0	27.8
250	27.6	
315	28.9	
400	28.1	28.7
500	29.2	
630	29.0	
800	28.6	29.3
1000	29.3	
1250	30.2	
1600	30.6	32.2
2000	32.4	
2500	34.3	
3150	36.9	38.2
4000	38.2	
5000	40.2	
6300+	42.5	42.2
8000+	41.7	
10000+	42.3	
Average 100-3150	28.7	

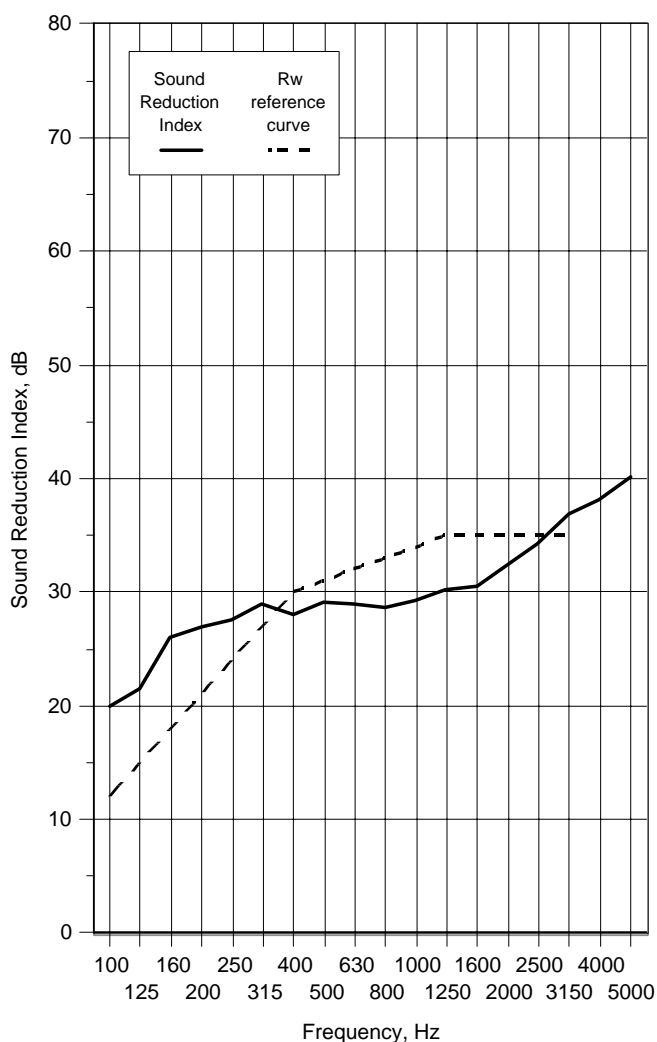

Rating according to BS EN ISO 717-1:1997

Rw(C;Ctr)= **31 (-1;-2)** dB

Notes * designates measurement corrected for background
 # designates limit of measurement due to background
 + designates frequency beyond standard and not UKAS accredited

v1.6

Test Number : 50 **Air temperature:** 16 °C
Client: Norsound Ltd **Air humidity:** 77 %
Test Date: 04/06/2008 **Receiving room volume** 300 m3
Sample height: 2.115 m **Source room volume:** 115 m3
Sample width: 1.006 m **Sample weight:** 25.5 kg/m2
Product Single leaf Flamebreak 430
Identification: Glazing=16mm Pyrobel (25% of door leaf area)
 Threshold=810
 Head, hanging jamb & closing jamb=710

Freq f Hz	Sound Reduction Index, dB	
	1/3 Oct	1/1 Oct
50+	24.9	22.8
63+	22.9	
80+	21.4	
100	23.2	25.1
125	25.1	
160	28.4	
200	28.2	28.8
250	28.7	
315	29.6	
400	26.8	27.6
500	28.4	
630	27.8	
800	27.9	29.5
1000	29.5	
1250	31.9	
1600	34.2	35.6
2000	36.1	
2500	37.0	
3150	38.2	39.3
4000	38.7	
5000	41.6	
6300+	43.7	43.2
8000+	43.1	
10000+	42.7	
Average 100-3150	30.1	

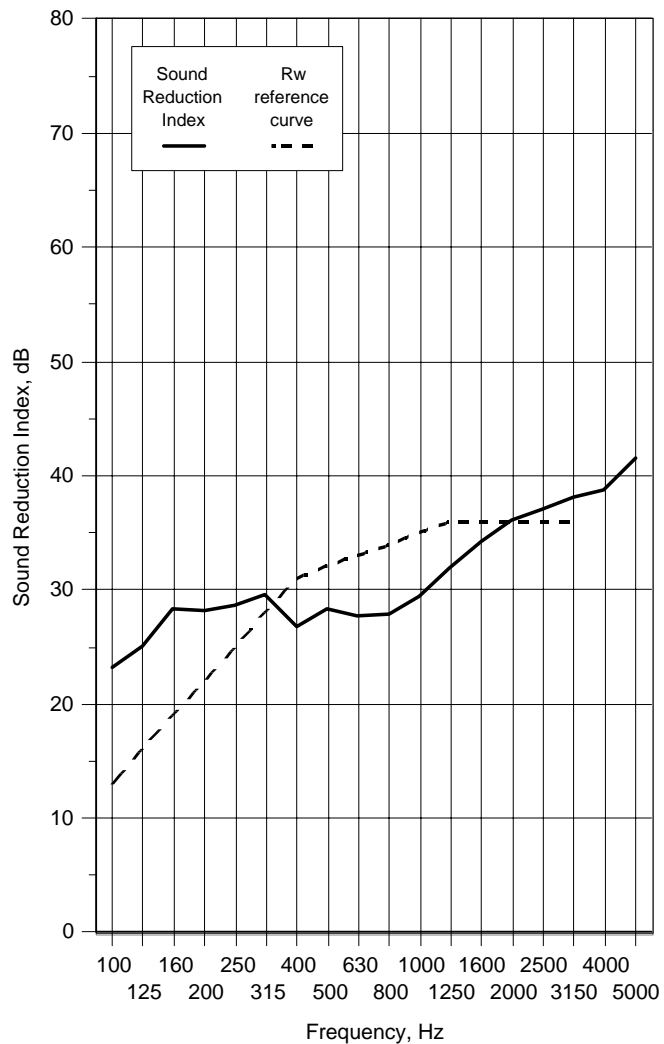

Rating according to BS EN ISO 717-1:1997

Rw(C;Ctr)= **32 (-1;-2)** dB

Notes * designates measurement corrected for background

designates limit of measurement due to background

+ designates frequency beyond standard and not UKAS accredited

v1.6

Test Number : 51 **Air temperature:** 16 °C
Client: Norsound Ltd **Air humidity:** 78 %
Test Date: 04/06/2008 **Receiving room volume** 300 m3
Sample height: 2.115 m **Source room volume:** 115 m3
Sample width: 1.006 m **Sample weight:** 20.4 kg/m2
Product Single leaf Flamebreak 430
Identification: Glazing=11.5 3Ply PA Res Glass (25% of door leaf area)
Threshold=810
Head, hanging jamb & closing jamb=710

Freq f Hz	Sound Reduction Index, dB	
	1/3 Oct	1/1 Oct
50+	22.3	21.2
63+	22.4	
80+	19.7	
100	21.6	23.4
125	23.0	
160	27.2	
200	27.9	28.2
250	27.7	
315	29.2	
400	27.0	28.1
500	29.0	
630	28.6	
800	28.4	29.2
1000	29.1	
1250	30.3	
1600	32.8	34.5
2000	35.1	
2500	36.5	
3150	37.8	38.4
4000	37.9	
5000	39.9	
6300+	42.6	42.4
8000+	42.3	
10000+	42.4	
Average 100-3150	29.5	

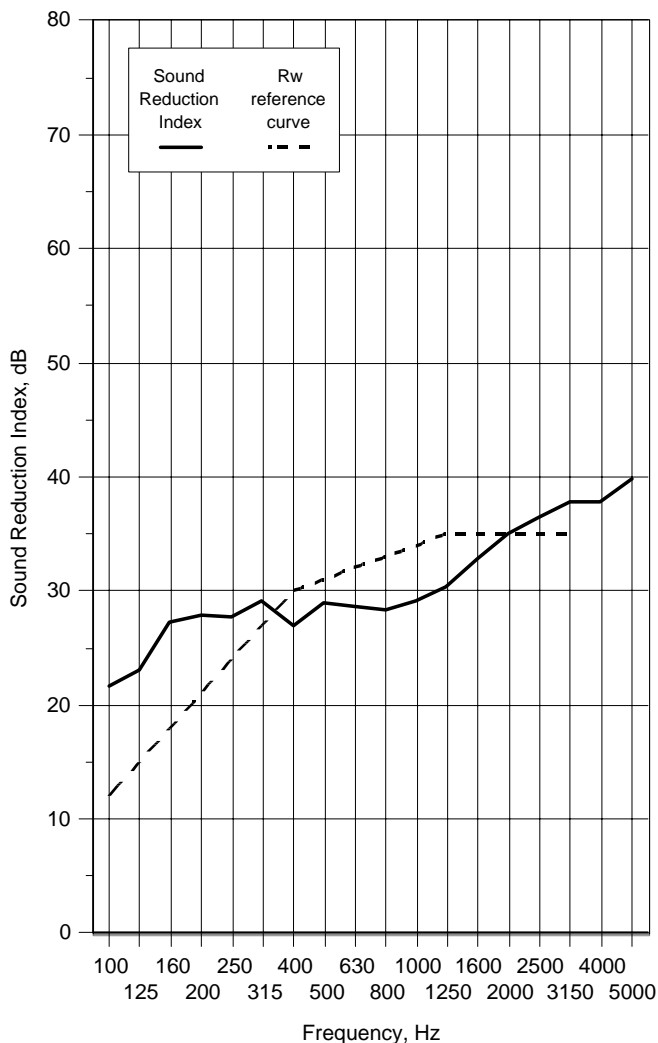

Rating according to BS EN ISO 717-1:1997

Rw(C;Ctr)= **31 (0;-2)** dB

Notes * designates measurement corrected for background

designates limit of measurement due to background

+ designates frequency beyond standard and not UKAS accredited

v1.6

Test Number :	52	Air temperature:	15.9 °C
Client:	Norsound Ltd	Air humidity:	78 %
Test Date:	04/06/2008	Receiving room volume	300 m3
Sample height:	2.115 m	Source room volume:	115 m3
Sample width:	1.006 m	Sample weight:	18.3 kg/m2
Product	Single leaf Flamebreak 430		
Identification:	Glazing=7mm Pyrobelite (25% of door leaf area)		
	Threshold=810		
	Head, hanging jamb & closing jamb=710		

Freq f Hz	Sound Reduction Index, dB	
	1/3 Oct	1/1 Oct
50+	22.1	20.3
63+	21.7	
80+	18.1	
100	20.2	21.6
125	20.6	
160	25.9	
200	27.2	28.1
250	28.2	
315	29.2	
400	28.6	29.2
500	29.6	
630	29.4	
800	28.9	29.8
1000	30.0	
1250	30.8	
1600	32.2	34.0
2000	34.5	
2500	36.4	
3150	38.6	39.4
4000	39.0	
5000	41.1	
6300+	43.2	43.2
8000+	43.1	
10000+	43.3	
Average 100-3150	29.4	

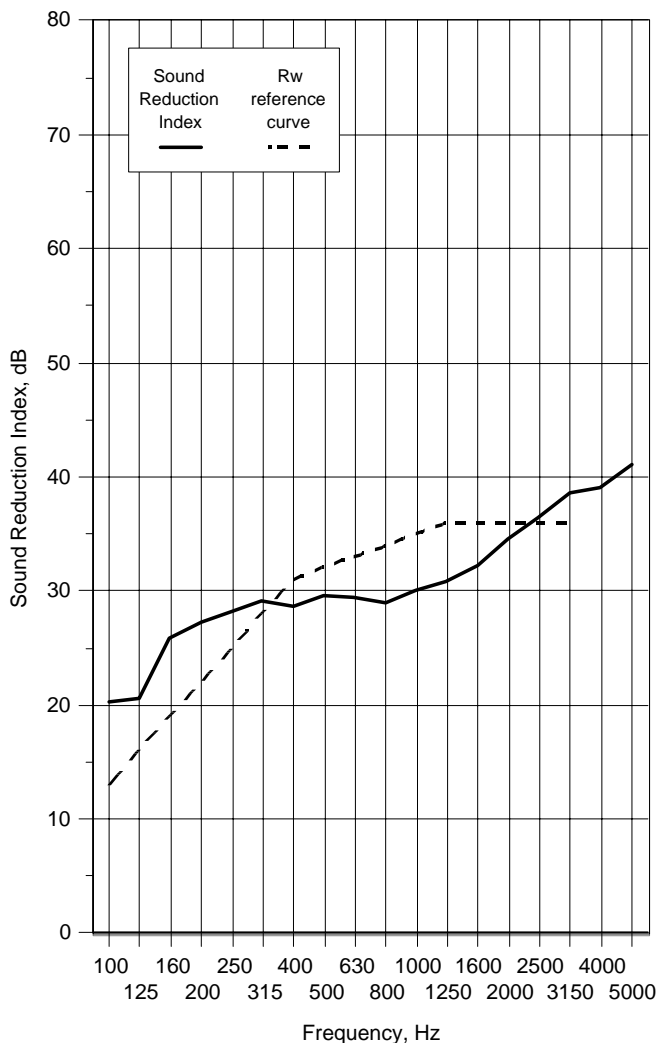

Rating according to BS EN ISO 717-1:1997

Rw(C;Ctr)= **32 (-1;-3)** dB

Notes * designates measurement corrected for background

designates limit of measurement due to background

+ designates frequency beyond standard and not UKAS accredited

v1.6

Test Number :	53	Air temperature:	15.9 °C
Client:	Norsound Ltd	Air humidity:	78 %
Test Date:	04/06/2008	Receiving room volume	300 m ³
Sample height:	2.115 m	Source room volume:	115 m ³
Sample width:	1.006 m	Sample weight:	25.2 kg/m ²
Product	Single leaf Strebord 44		
Identification:	Glazing=6mm Pyroshield (25% of door leaf area)		
	Threshold=810		
	Head, hanging jamb & closing jamb=710		

Freq f Hz	Sound Reduction Index, dB	
	1/3 Oct	1/1 Oct
50+	24.8	22.6
63+	25.4	
80+	19.8	
100	21.6	23.7
125	23.9	
160	27.8	
200	28.1	29.6
250	30.0	
315	31.1	
400	30.8	31.9
500	32.5	
630	32.6	
800	31.5	31.0
1000	31.0	
1250	30.5	
1600	30.5	32.0
2000	31.8	
2500	34.3	
3150	36.8	37.5
4000	38.1	
5000	37.7	
6300+	40.0	40.9
8000+	40.8	
10000+	42.3	
Average 100-3150	30.3	

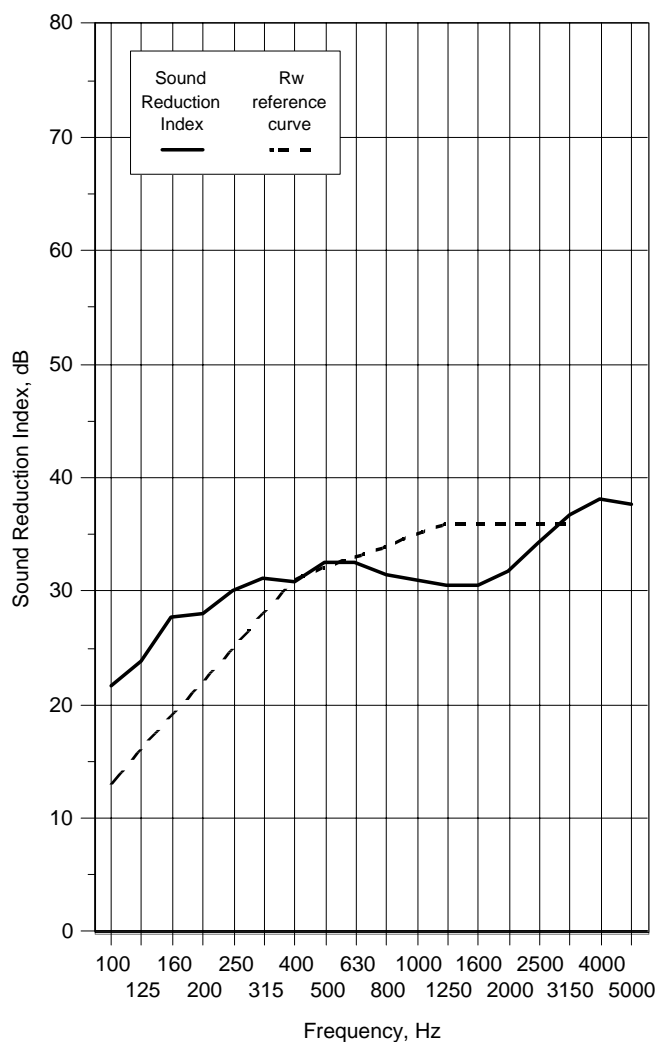

Rating according to BS EN ISO 717-1:1997

Rw(C;Ctr)= **32 (0;-1) dB**

Notes * designates measurement corrected for background
 # designates limit of measurement due to background
 + designates frequency beyond standard and not UKAS accredited

v1.6

Test Number :	54	Air temperature:	15.9 °C
Client:	Norsound Ltd	Air humidity:	79 %
Test Date:	04/06/2008	Receiving room volume	300 m3
Sample height:	2.115 m	Source room volume:	115 m3
Sample width:	1.006 m	Sample weight:	24.6 kg/m2
Product	Single leaf Strebord 44		
Identification:	Glazing=7mm Pyrobelite (25% of door leaf area)		
	Threshold=810		
	Head, hanging jamb & closing jamb=710		

Freq f Hz	Sound Reduction Index, dB	
	1/3 Oct	1/1 Oct
50+	24.4	21.1
63+	25.9	
80+	17.7	
100	21.2	23.5
125	23.7	
160	28.1	
200	28.2	
250	30.1	29.8
315	31.6	
400	30.9	
500	32.6	32.1
630	33.0	
800	32.3	31.3
1000	31.4	
1250	30.5	
1600	31.0	
2000	33.2	
2500	35.2	32.8
3150	37.6	
4000	38.6	
5000	37.2	37.8
6300+	39.7	
8000+	40.7	
10000+	42.8	40.9
Average 100-3150	30.7	

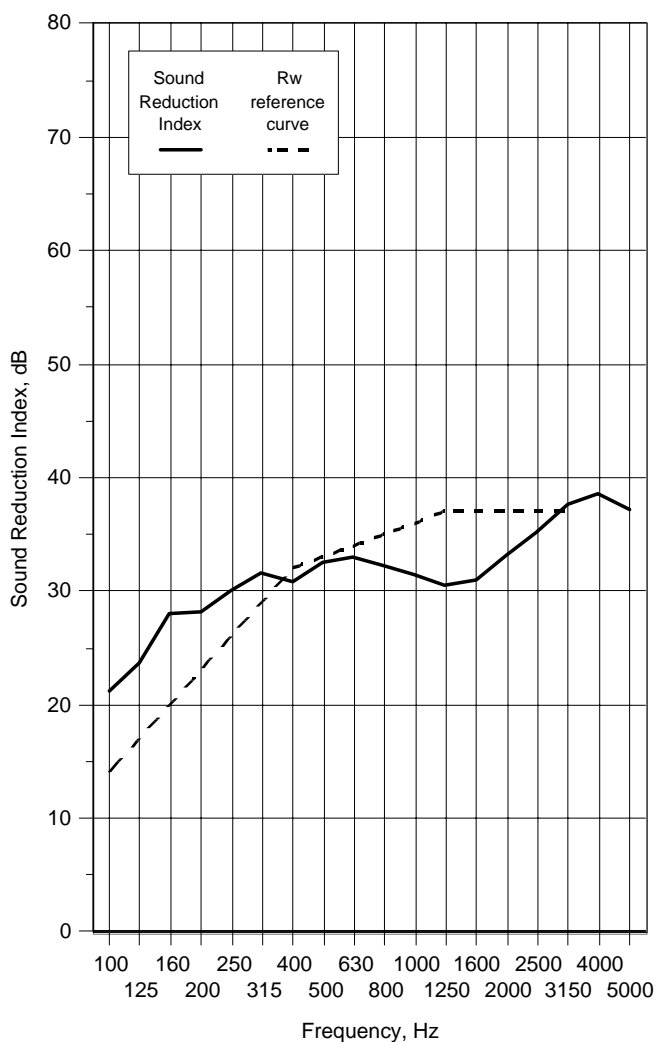

Rating according to BS EN ISO 717-1:1997

Rw(C;Ctr)= **33 (-1;-2)** dB

Notes * designates measurement corrected for background
 # designates limit of measurement due to background
 + designates frequency beyond standard and not UKAS accredited

v1.6

Test Number :	55	Air temperature:	16 °C
Client:	Norsound Ltd	Air humidity:	79 %
Test Date:	04/06/2008	Receiving room volume	300 m ³
Sample height:	2.115 m	Source room volume:	115 m ³
Sample width:	1.006 m	Sample weight:	17.3 kg/m ²
Product	Single leaf Flamebreak 430		
Identification:	Fully caulked		

Freq f Hz	Sound Reduction Index, dB	
	1/3 Oct	1/1 Oct
50+	27.3	15.9
63+	24.1	
80+	11.5	
100	11.5	14.5
125	15.4	
160	21.8	
200	24.0	23.5
250	23.2	
315	23.3	
400	25.3	26.5
500	27.3	
630	27.0	
800	28.0	29.4
1000	29.4	
1250	31.5	
1600	33.6	34.8
2000	34.9	
2500	36.1	
3150	38.2	40.0
4000	40.3	
5000	42.3	
6300+	44.5	44.7
8000+	45.0	
10000+	44.6	
Average 100-3150	26.9	

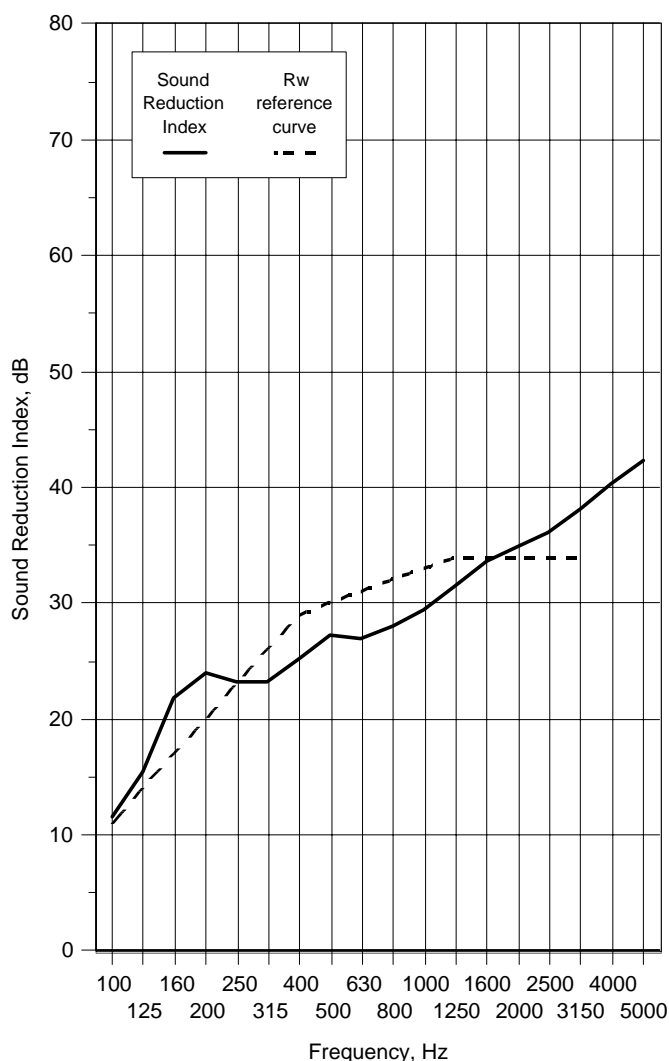

Rating according to BS EN ISO 717-1:1997

Rw(C;Ctr)= **30 (-1;-4)** dB

Notes * designates measurement corrected for background

designates limit of measurement due to background

+ designates frequency beyond standard and not UKAS accredited

v1.6

Test Number :	56	Air temperature:	16.1 °C
Client:	Norsound Ltd	Air humidity:	80 %
Test Date:	04/06/2008	Receiving room volume	300 m ³
Sample height:	2.115 m	Source room volume:	115 m ³
Sample width:	1.006 m	Sample weight:	17.3 kg/m ²
Product	Single leaf Flamebreak 430		
Identification:	Threshold=810		
	Head, hanging jamb & closing jamb=710		

Freq f Hz	Sound Reduction Index, dB	
	1/3 Oct	1/1 Oct
50+	25.9	13.3
63+	19.9	
80+	9.0	
100	13.6	16.2
125	16.5	
160	23.3	
200	22.7	23.1
250	23.0	
315	23.4	
400	24.2	25.3
500	26.2	
630	25.8	
800	25.6	27.1
1000	27.0	
1250	29.4	
1600	31.8	33.0
2000	33.4	
2500	34.2	
3150	36.4	36.9
4000	36.6	
5000	38.1	
6300+	40.9	41.7
8000+	41.8	
10000+	42.6	
Average 100-3150	26.0	

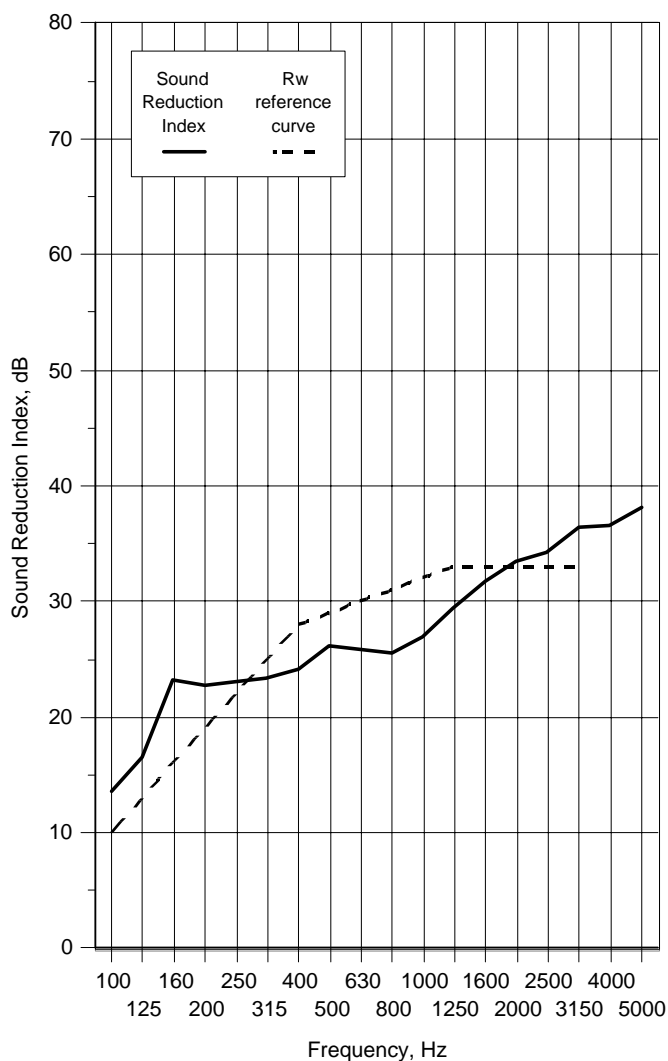

Rating according to BS EN ISO 717-1:1997

Rw(C;Ctr)= **29 (-1;-3) dB**

Notes * designates measurement corrected for background

designates limit of measurement due to background

+ designates frequency beyond standard and not UKAS accredited

v1.6

Test Number : 57 **Air temperature:** 16.3 °C
Client: Norsound Ltd **Air humidity:** 80 %
Test Date: 04/06/2008 **Receiving room volume** 300 m3
Sample height: 2.115 m **Source room volume:** 115 m3
Sample width: 1.006 m **Sample weight:** 17.3 kg/m2
Product Single leaf Flamebreak 430
Identification: Threshold=850 used with 650 threshold
 Head, hanging jamb & closing jamb=710

Freq f Hz	Sound Reduction Index, dB	
	1/3 Oct	1/1 Oct
50+	28.3	14.4
63+	23.1	
80+	9.9	
100	10.5	13.9
125	16.0	
160	20.9	
200	23.3	23.1
250	22.6	
315	23.3	
400	24.8	25.8
500	26.6	
630	26.4	
800	26.9	28.5
1000	28.7	
1250	30.5	
1600	32.1	33.2
2000	33.4	
2500	34.5	
3150	37.1	38.6
4000	38.9	
5000	40.6	
6300+	42.3	42.7
8000+	42.4	
10000+	43.3	
Average 100-3150	26.1	

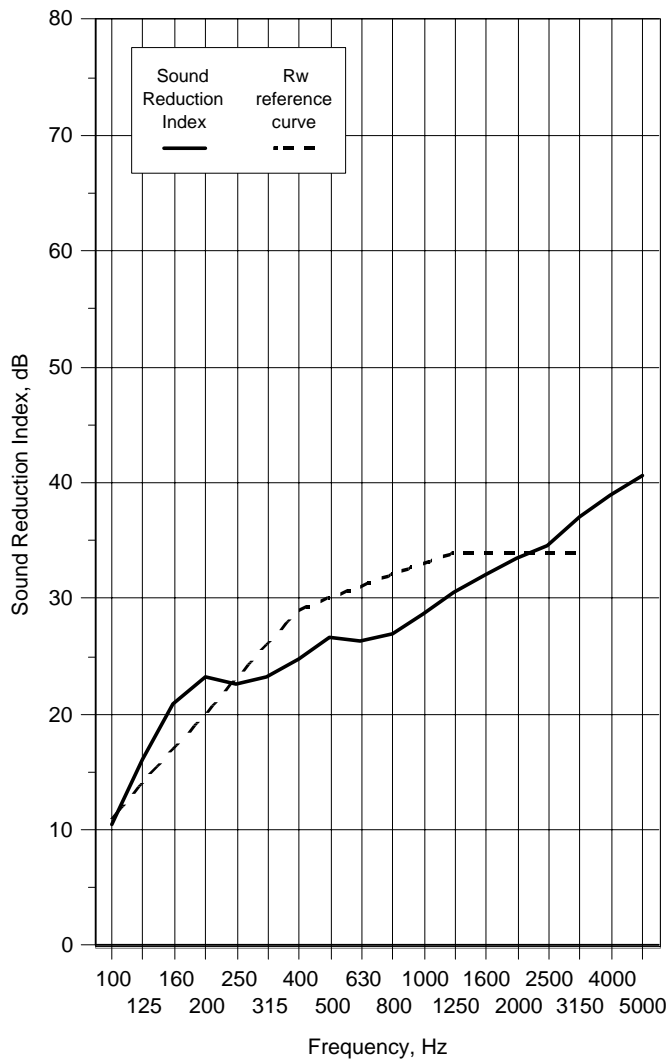

Rating according to BS EN ISO 717-1:1997

Rw(C;Ctr)= **30 (-1;-5)** dB

Notes * designates measurement corrected for background
 # designates limit of measurement due to background
 + designates frequency beyond standard and not UKAS accredited

vt.6

Test Number :	58	Air temperature:	16.5 °C
Client:	Norsound Ltd	Air humidity:	81 %
Test Date:	04/06/2008	Receiving room volume	300 m3
Sample height:	2.115 m	Source room volume:	115 m3
Sample width:	1.006 m	Sample weight:	26.3 kg/m2
Product	Single leaf Strebord 44		
Identification:	Fully caulked		

Freq f Hz	Sound Reduction Index, dB	
	1/3 Oct	1/1 Oct
50+	18.4	18.9
63+	20.1	
80+	18.4	
100	21.3	23.6
125	23.5	
160	28.6	
200	25.7	28.0
250	28.8	
315	31.5	
400	31.3	32.5
500	33.2	
630	33.4	
800	31.5	30.8
1000	29.9	
1250	31.1	
1600	33.3	34.8
2000	35.1	
2500	36.5	
3150	38.4	38.7
4000	39.9	
5000	38.1	
6300+	40.0	41.5
8000+	41.2	
10000+	44.2	
Average 100-3150	30.8	

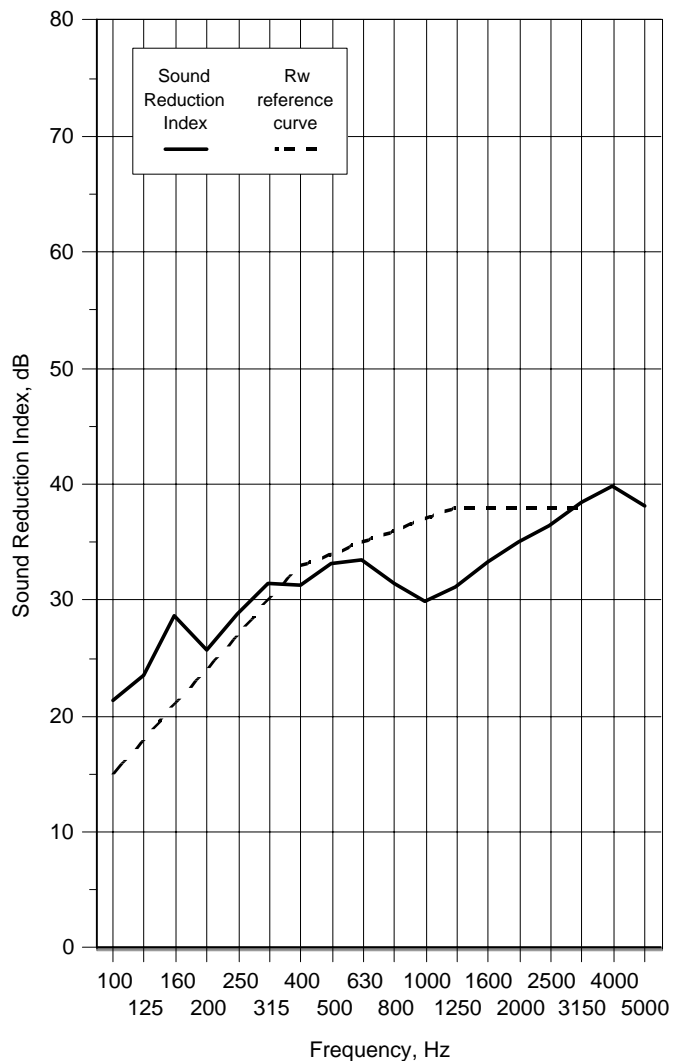

Rating according to BS EN ISO 717-1:1997

Rw(C;Ctr)= **34 (-1;-3)** dB

Notes * designates measurement corrected for background
 # designates limit of measurement due to background
 + designates frequency beyond standard and not UKAS accredited

v1.6

Test Number :	59	Air temperature:	16.6 °C
Client:	Norsound Ltd	Air humidity:	81 %
Test Date:	04/06/2008	Receiving room volume	300 m3
Sample height:	2.115 m	Source room volume:	115 m3
Sample width:	1.006 m	Sample weight:	26.3 kg/m2
Product	Single leaf Strebord 44		
Identification:	Threshold=850 used with 650 threshold Head, hanging jamb & closing jamb=710		

Freq f Hz	Sound Reduction Index, dB	
	1/3 Oct	1/1 Oct
50+	15.6	
63+	18.9	17.4
80+	18.3	
100	21.7	
125	23.6	23.8
160	28.3	
200	25.9	
250	28.8	28.1
315	31.5	
400	31.1	
500	33.0	32.3
630	32.9	
800	30.5	
1000	28.6	29.6
1250	29.9	
1600	32.3	
2000	34.1	33.7
2500	35.2	
3150	37.3	
4000	39.0	37.9
5000	37.7	
6300+	39.5	
8000+	40.4	40.8
10000+	43.4	
Average 100-3150	30.3	

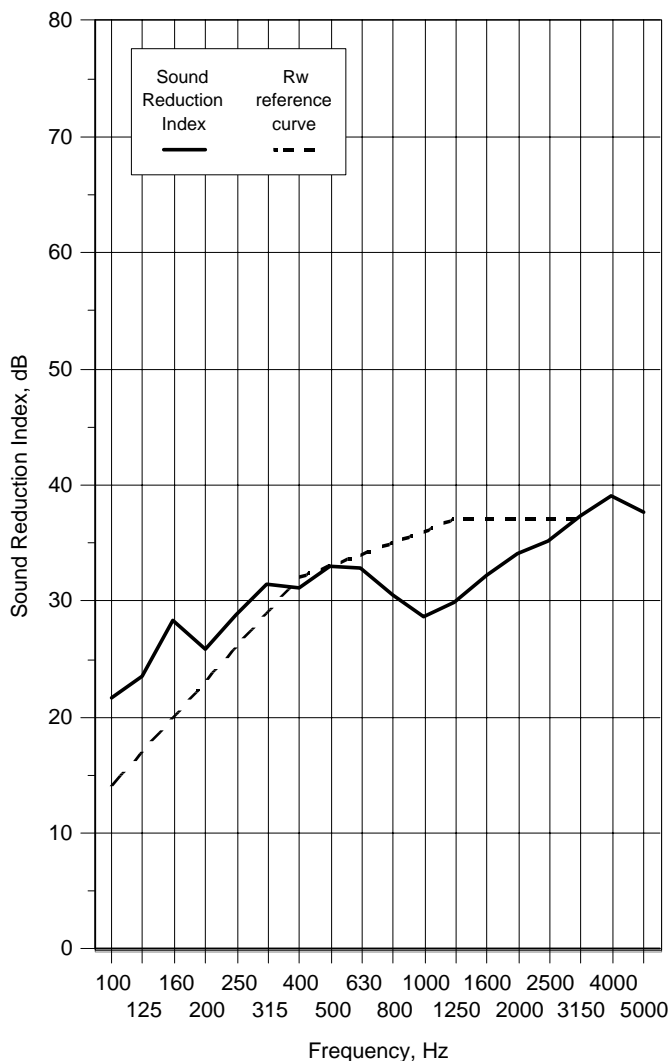

Rating according to BS EN ISO 717-1:1997

Rw(C;Ctr)= **33 (-1;-3) dB**

Notes * designates measurement corrected for background

designates limit of measurement due to background

+ designates frequency beyond standard and not UKAS accredited

v1.6

Test Number : 60
Client: Norsound Ltd
Test Date: 03/06/2008
Sample height: 2.115 m
Sample width: 1.006 m
Product Single leaf Flamebreak 660
Identification: Glazing=6mm Pyroshield (25% of door leaf area)
 Threshold=810+650A
 Head, hanging jamb & closing jamb=710

Air temperature: 16.7 °C
Air humidity: 83 %
Receiving room volume 300 m3
Source room volume: 115 m3
Sample weight: 24.3 kg/m2

Freq f Hz	Sound Reduction Index, dB	
	1/3 Oct	1/1 Oct
50+	23.2	21.5
63+	25.0	
80+	18.8	
100	22.6	24.1
125	23.2	
160	28.0	
200	28.8	30.0
250	30.4	
315	31.3	
400	30.1	31.4
500	31.7	
630	32.8	
800	33.1	33.6
1000	33.6	
1250	33.9	
1600	32.3	34.4
2000	34.9	
2500	37.8	
3150	40.7	42.3
4000	42.8	
5000	44.3	
6300+	46.3	44.9
8000+	45.3	
10000+	43.6	
Average 100-3150	31.6	

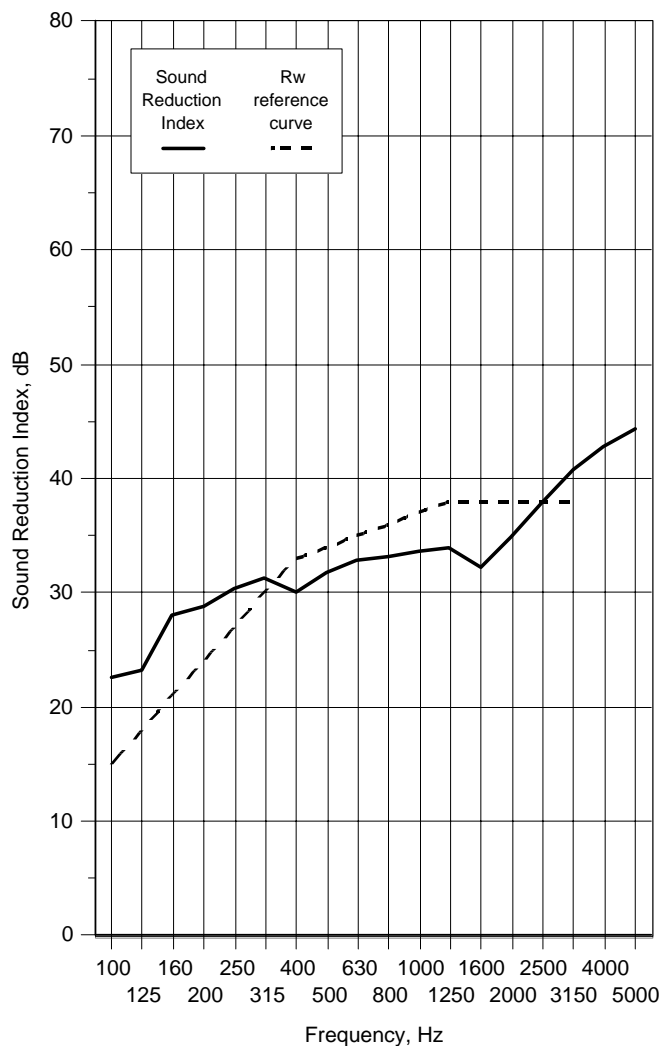

Rating according to BS EN ISO 717-1:1997

Rw(C;Ctr)= **34 (0;-2) dB**

Notes * designates measurement corrected for background

designates limit of measurement due to background

+ designates frequency beyond standard and not UKAS accredited

v1.6

Test Number :	61	Air temperature:	16.6 °C
Client:	Norsound Ltd	Air humidity:	81 %
Test Date:	04/06/2008	Receiving room volume	300 m3
Sample height:	2.115 m	Source room volume:	115 m3
Sample width:	1.006 m	Sample weight:	26.3 kg/m2
Product	Single leaf Strebord 44		
Identification:	Threshold=815		
	Head, hanging jamb & closing jamb=710		

Freq f Hz	Sound Reduction Index, dB	
	1/3 Oct	1/1 Oct
50+	13.9	15.9
63+	17.5	
80+	17.6	
100	20.5	23.1
125	24.0	
160	27.5	
200	25.5	27.8
250	28.7	
315	31.0	
400	30.6	31.8
500	32.7	
630	32.4	
800	30.1	29.0
1000	28.2	
1250	29.1	
1600	31.0	32.5
2000	33.0	
2500	34.1	
3150	36.2	37.2
4000	38.5	
5000	37.3	
6300+	39.0	40.8
8000+	40.6	
10000+	44.1	
Average 100-3150	29.7	

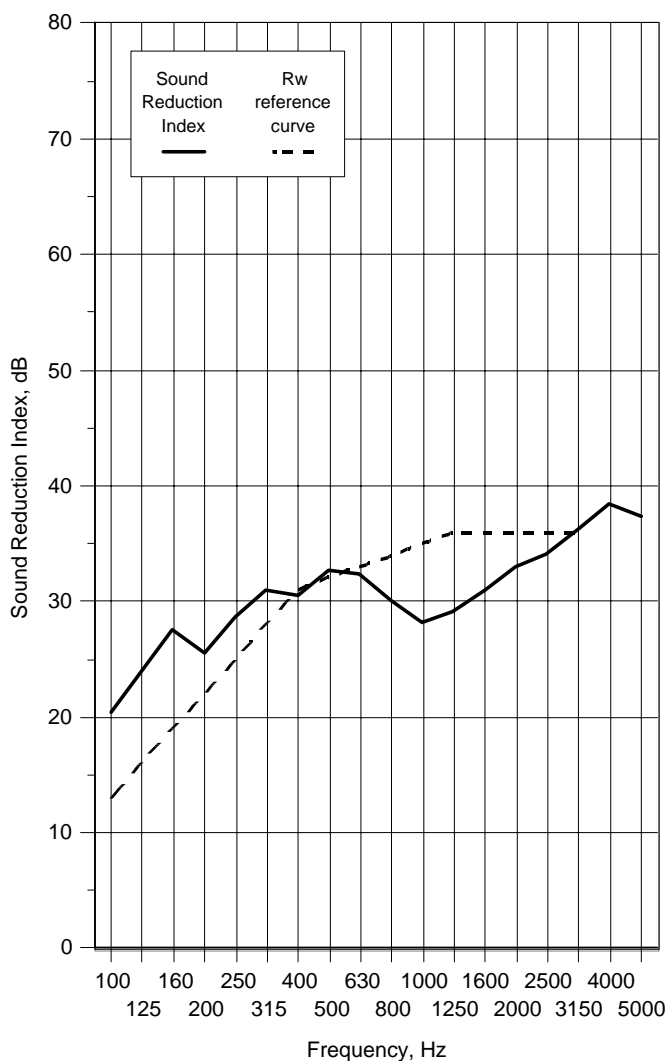

Rating according to BS EN ISO 717-1:1997

Rw(C;Ctr)= **32 (-1;-2)** dB

Notes * designates measurement corrected for background
 # designates limit of measurement due to background
 + designates frequency beyond standard and not UKAS accredited

v1.6

Test Number :	62	Air temperature:	16.8 °C
Client:	Norsound Ltd	Air humidity:	81 %
Test Date:	04/06/2008	Receiving room volume	300 m ³
Sample height:	2.115 m	Source room volume:	115 m ³
Sample width:	1.006 m	Sample weight:	26.3 kg/m ²
Product	Single leaf Strebord 44		
Identification:	Threshold=815		
	Head, hanging jamb & closing jamb=755		

Freq f Hz	Sound Reduction Index, dB	
	1/3 Oct	1/1 Oct
50+	24.4	21.3
63+	26.9	
80+	17.8	
100	20.4	22.9
125	23.5	
160	27.5	
200	28.1	29.8
250	29.7	
315	32.7	
400	32.9	33.3
500	33.8	
630	33.2	
800	30.5	28.4
1000	27.8	
1250	27.4	
1600	29.1	31.0
2000	31.7	
2500	33.5	
3150	34.9	35.4
4000	35.9	
5000	35.4	
6300+	38.2	39.8
8000+	39.7	
10000+	43.0	
Average 100-3150	29.8	

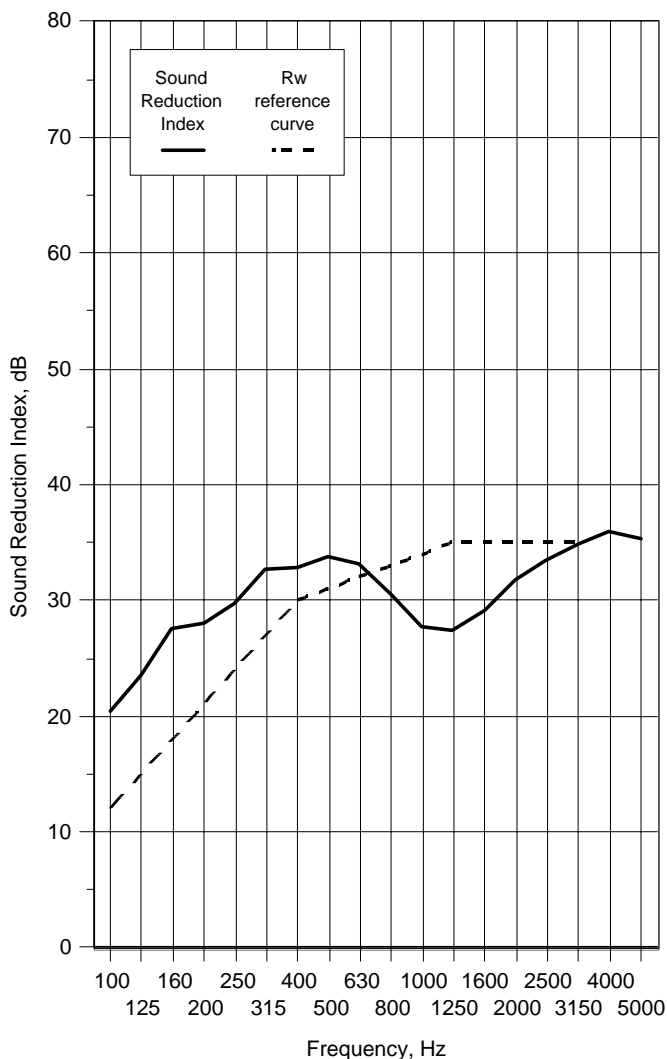

Rating according to BS EN ISO 717-1:1997

Rw(C;Ctr)= **31 (-1;-2)** dB

Notes * designates measurement corrected for background

designates limit of measurement due to background

+ designates frequency beyond standard and not UKAS accredited

v1.6

Test Number :	63	Air temperature:	16.9 °C
Client:	Norsound Ltd	Air humidity:	81 %
Test Date:	04/06/2008	Receiving room volume	300 m3
Sample height:	2.115 m	Source room volume:	115 m3
Sample width:	1.006 m	Sample weight:	26.3 kg/m2
Product	Single leaf Strebord 44		
Identification:	Threshold=810 used with 615 threshold		
	Head, hanging jamb & closing jamb=710		

Freq f Hz	Sound Reduction Index, dB	
	1/3 Oct	1/1 Oct
50+	14.7	16.6
63+	18.7	
80+	17.2	
100	20.0	22.6
125	23.3	
160	27.0	27.5
200	25.3	
250	28.5	
315	30.3	
400	30.1	30.7
500	31.6	
630	30.7	
800	29.3	28.6
1000	27.6	
1250	29.1	
1600	31.5	
2000	33.4	33.0
2500	34.6	
3150	35.7	
4000	35.3	35.3
5000	34.9	
6300+	37.2	
8000+	38.9	38.7
10000+	40.8	
Average 100-3150	29.3	

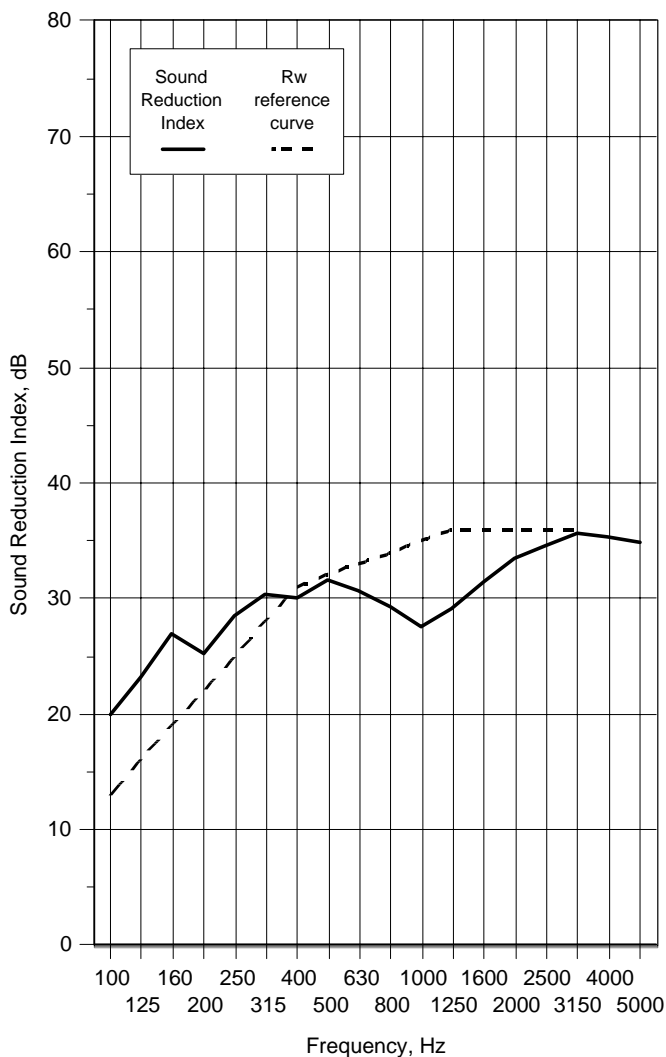

Rating according to BS EN ISO 717-1:1997

Rw(C;Ctr)= **32 (-1;-3)** dB

Notes * designates measurement corrected for background

designates limit of measurement due to background

+ designates frequency beyond standard and not UKAS accredited

v1.6

Test Number :	64	Air temperature:	16.9 °C
Client:	Norsound Ltd	Air humidity:	81 %
Test Date:	04/06/2008	Receiving room volume	300 m ³
Sample height:	2.115 m	Source room volume:	115 m ³
Sample width:	1.006 m	Sample weight:	26.3 kg/m ²
Product	Single leaf Strebord 44		
Identification:	Threshold=850 used with 615 threshold Head, hanging jamb & closing jamb=710		

Freq f Hz	Sound Reduction Index, dB	
	1/3 Oct	1/1 Oct
50+	15.8	17.7
63+	19.9	
80+	18.6	
100	21.1	23.3
125	23.3	
160	27.6	28.1
200	25.6	
250	29.2	
315	31.6	32.3
400	31.3	
500	33.1	
630	32.7	29.1
800	30.3	
1000	28.0	
1250	29.3	33.0
1600	31.4	
2000	33.4	
2500	34.8	37.0
3150	36.6	
4000	37.6	
5000	36.8	39.1
6300+	38.1	
8000+	38.8	
10000+	40.9	
Average 100-3150	30.0	

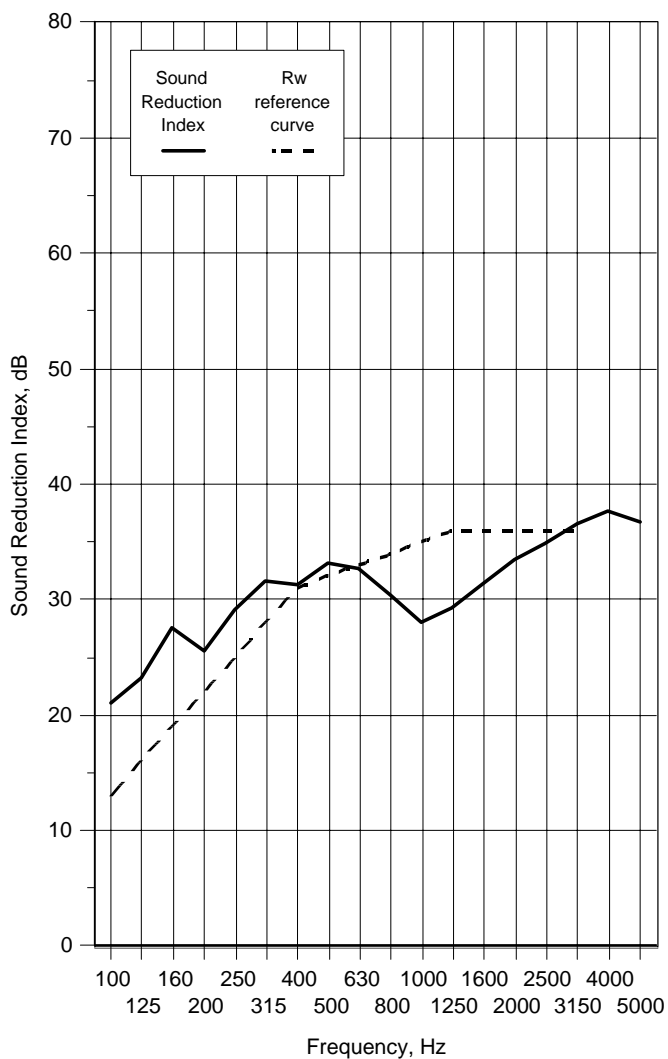

Rating according to BS EN ISO 717-1:1997

Rw(C;Ctr)= **32 (-1;-2)** dB

Notes * designates measurement corrected for background

designates limit of measurement due to background

+ designates frequency beyond standard and not UKAS accredited

v1.6

Test Number : 65
Client: Norsound Ltd
Test Date: 04/06/2008
Sample height: 2.115 m
Sample width: 1.006 m
Product Single leaf Strebord 44
Identification: Threshold=2 x 720 used with 615 threshold
 Head, hanging jamb & closing jamb=710
Air temperature: 16.9 °C
Air humidity: 81 %
Receiving room volume 300 m3
Source room volume: 115 m3
Sample weight: 26.3 kg/m2

Freq f Hz	Sound Reduction Index, dB	
	1/3 Oct	1/1 Oct
50+	15.1	16.9
63+	18.6	
80+	18.0	23.4
100	20.9	
125	23.9	
160	28.0	28.1
200	25.7	
250	29.1	
315	31.5	
400	31.4	32.4
500	33.3	
630	32.9	
800	30.4	29.2
1000	28.1	
1250	29.4	
1600	31.5	
2000	33.5	33.0
2500	34.7	
3150	36.9	37.6
4000	38.6	
5000	37.4	
6300+	39.1	40.7
8000+	40.5	
10000+	43.6	
Average 100-3150	30.1	

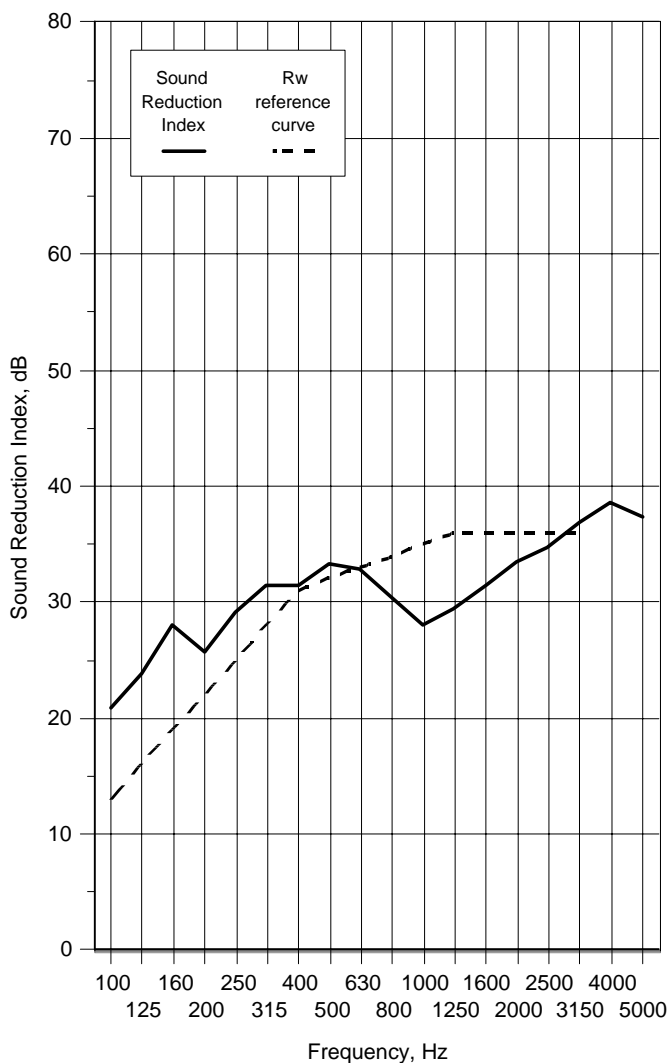

Rating according to BS EN ISO 717-1:1997

Rw(C;Ctr)= **32 (-1;-2)** dB

Notes * designates measurement corrected for background

designates limit of measurement due to background

+ designates frequency beyond standard and not UKAS accredited

v1.6

Test Number :	66	Air temperature:	16.9 °C
Client:	Norsound Ltd	Air humidity:	81 %
Test Date:	04/06/2008	Receiving room volume	300 m3
Sample height:	2.115 m	Source room volume:	115 m3
Sample width:	1.006 m	Sample weight:	26.3 kg/m2
Product	Single leaf Strebord 44		
Identification:	Threshold=810 used with 650 threshold Head, hanging jamb & closing jamb=710		

Freq f Hz	Sound Reduction Index, dB	
	1/3 Oct	1/1 Oct
50+	15.1	16.9
63+	18.4	
80+	18.1	
100	21.1	23.4
125	23.6	
160	28.2	
200	26.0	28.4
250	29.3	
315	31.7	
400	31.6	32.7
500	33.5	
630	33.3	
800	30.7	29.4
1000	28.3	
1250	29.3	
1600	31.6	33.3
2000	33.8	
2500	35.3	
3150	37.3	37.8
4000	38.8	
5000	37.3	
6300+	39.2	40.8
8000+	40.8	
10000+	43.8	
Average 100-3150	30.3	

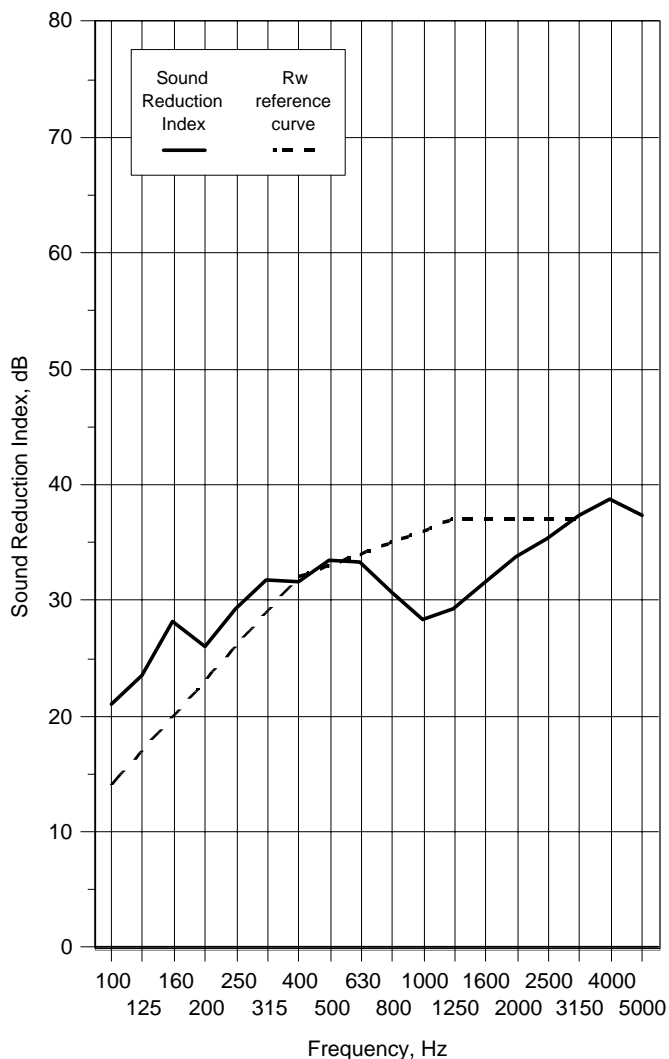

Rating according to BS EN ISO 717-1:1997

Rw(C;Ctr)= **33 (-2;-3) dB**

Notes * designates measurement corrected for background
 # designates limit of measurement due to background
 + designates frequency beyond standard and not UKAS accredited

v1.6

Test Number :	67	Air temperature:	16.9 °C
Client:	Norsound Ltd	Air humidity:	81 %
Test Date:	04/06/2008	Receiving room volume	300 m3
Sample height:	2.115 m	Source room volume:	115 m3
Sample width:	1.006 m	Sample weight:	26.3 kg/m2
Product	Single leaf Strebord 44		
Identification:	Threshold=2x720 used with 650 threshold Head, hanging jamb & closing jamb=710		

Freq f Hz	Sound Reduction Index, dB	
	1/3 Oct	1/1 Oct
50+	14.1	16.0
63+	17.2	
80+	17.8	
100	20.8	23.2
125	23.4	
160	27.9	
200	26.1	28.3
250	29.1	
315	31.5	
400	31.2	32.4
500	33.2	
630	33.0	
800	30.5	29.3
1000	28.3	
1250	29.5	
1600	31.9	33.5
2000	34.0	
2500	35.2	
3150	37.2	37.7
4000	38.7	
5000	37.3	
6300+	39.2	40.7
8000+	40.5	
10000+	43.2	
Average 100-3150	30.2	

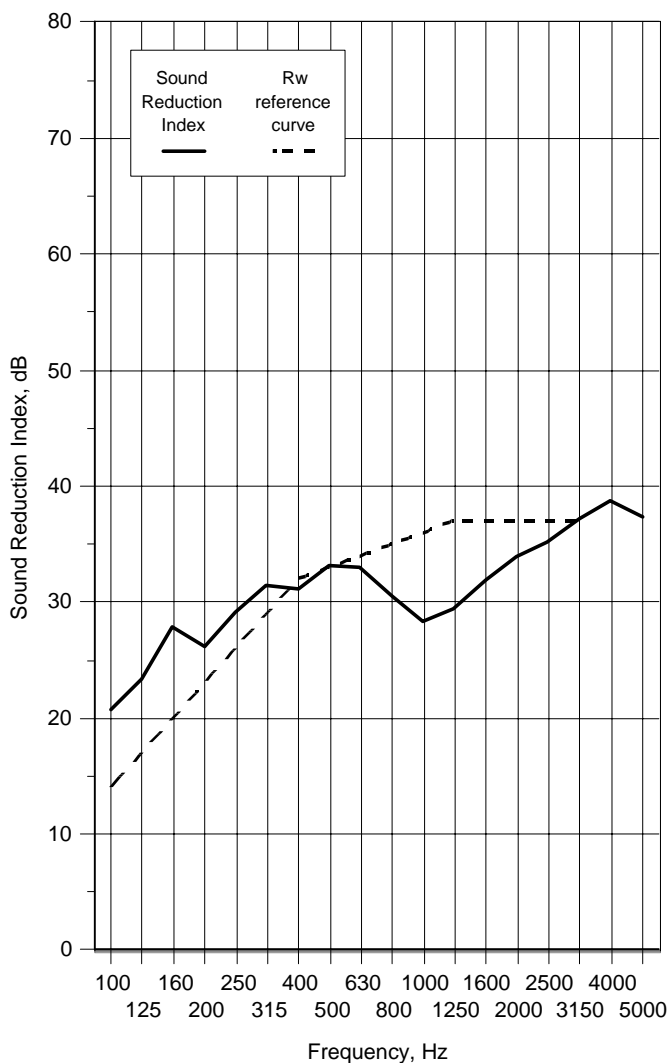

Rating according to BS EN ISO 717-1:1997

Rw(C;Ctr)= **33 (-2;-3) dB**

Notes * designates measurement corrected for background

designates limit of measurement due to background

+ designates frequency beyond standard and not UKAS accredited

v1.6

Test Number : 69 **Air temperature:** 16.7 °C
Client: Norsound Ltd **Air humidity:** 73 %
Test Date: 05/06/2008 **Receiving room volume:** 300 m3
Sample height: 2.115 m **Source room volume:** 115 m3
Sample width: 1.006 m **Sample weight:** 17.3 kg/m2
Product Unequal Pair Flamebreak 430. Meeting stiles= 720+510
Identification: Threshold=810 / 810
 Head, hanging jamb & closing jamb=710

Freq f Hz	Sound Reduction Index, dB	
	1/3 Oct	1/1 Oct
50+	23.2	19.3
63+	19.0	
80+	17.5	
100	22.5	22.9
125	21.8	
160	25.0	23.3
200	20.6	
250	25.2	
315	26.5	26.9
400	26.4	
500	27.7	
630	26.8	28.1
800	26.6	
1000	27.9	
1250	30.5	33.8
1600	32.6	
2000	34.2	
2500	35.1	37.7
3150	36.0	
4000	38.0	
5000	40.0	41.7
6300+	42.3	
8000+	41.5	
10000+	41.4	
Average 100-3150	27.8	

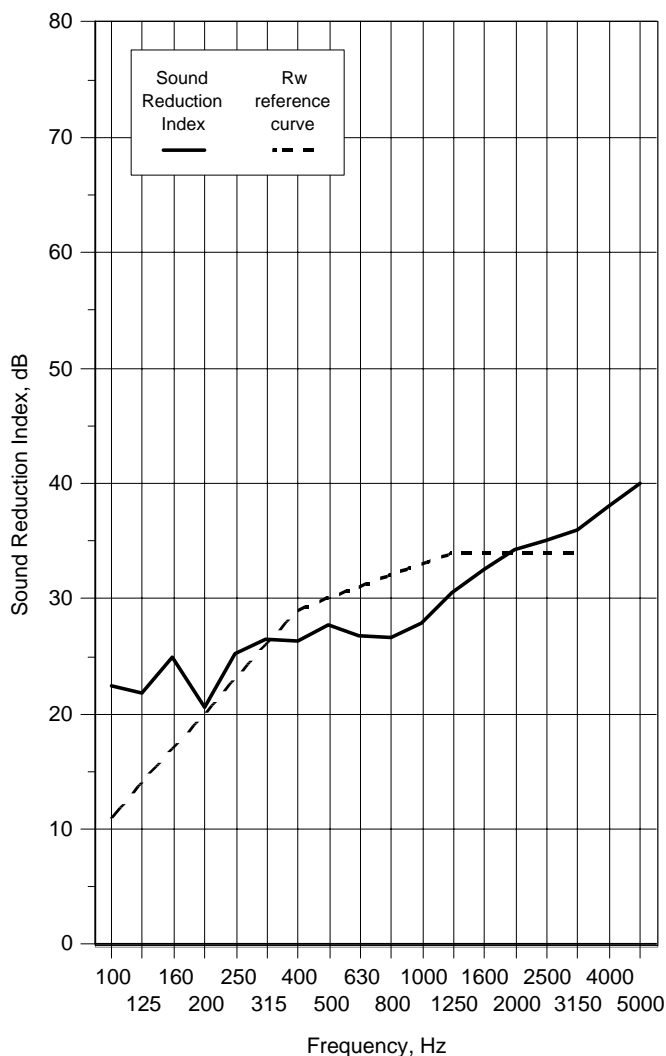

Rating according to BS EN ISO 717-1:1997

Rw(C;Ctr)= **30 (0;-2) dB**

Notes * designates measurement corrected for background
 # designates limit of measurement due to background
 + designates frequency beyond standard and not UKAS accredited

v1.6

Test Number : 70
Client: Norsound Ltd
Test Date: 05/06/2008
Sample height: 2.115 m
Sample width: 1.006 m
Product Identification: Unequal Pair Flamebreak 430. Meeting stiles= 2 x 755 + 720
 Threshold=810 / 810
 Head, hanging jamb & closing jamb=710
Air temperature: 16.7 °C
Air humidity: 73 %
Receiving room volume: 300 m3
Source room volume: 115 m3
Sample weight: 17.3 kg/m2

Freq f Hz	Sound Reduction Index, dB	
	1/3 Oct	1/1 Oct
50+	24.4	20.0
63+	24.4	
80+	16.4	
100	21.7	22.4
125	21.3	
160	25.3	25.1
200	23.5	
250	25.7	
315	26.9	
400	27.2	27.7
500	28.7	
630	27.5	28.5
800	27.0	
1000	28.4	
1250	30.7	33.2
1600	32.0	
2000	33.6	
2500	34.2	
3150	35.7	37.1
4000	37.3	
5000	39.0	
6300+	41.4	41.2
8000+	40.9	
10000+	41.1	
Average 100-3150	28.1	

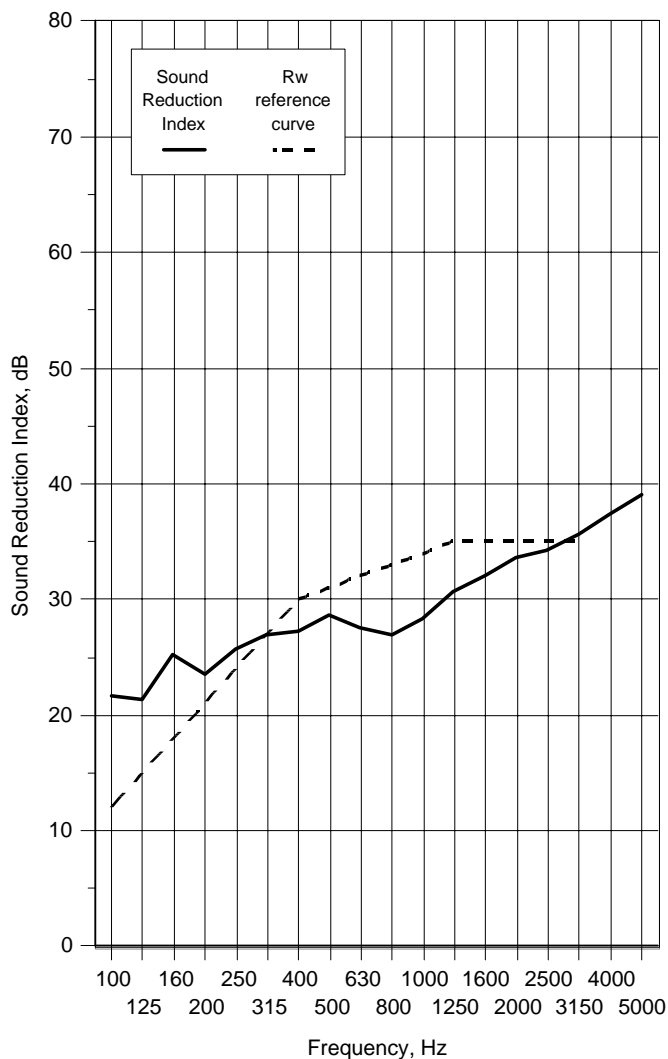

Rating according to BS EN ISO 717-1:1997

Rw(C;Ctr)= **31 (-1;-3)** dB

Notes * designates measurement corrected for background
 # designates limit of measurement due to background
 + designates frequency beyond standard and not UKAS accredited

v1.6

Test Number : 71
Client: Norsound Ltd
Test Date: 05/06/2008
Sample height: 2.115 m
Sample width: 1.006 m
Product Unequal Pair Flamebreak 430
Identification: Meeting stiles= 855 + 855 carrier only + 720
 Threshold=810 / 810
 Head, hanging jamb & closing jamb=710

Air temperature: 16.7 °C
Air humidity: 73 %
Receiving room volume 300 m3
Source room volume: 115 m3
Sample weight: 17.3 kg/m2

Freq f Hz	Sound Reduction Index, dB	
	1/3 Oct	1/1 Oct
50+	23.7	19.8
63+	23.9	
80+	16.4	
100	21.1	22.7
125	23.1	
160	24.8	
200	23.4	24.9
250	25.3	
315	26.7	
400	26.8	27.5
500	28.6	
630	27.3	
800	26.9	28.4
1000	28.4	
1250	30.6	
1600	31.8	33.1
2000	33.6	
2500	34.3	
3150	35.7	37.1
4000	37.2	
5000	38.9	
6300+	41.2	41.0
8000+	40.8	
10000+	41.1	
Average 100-3150	28.0	

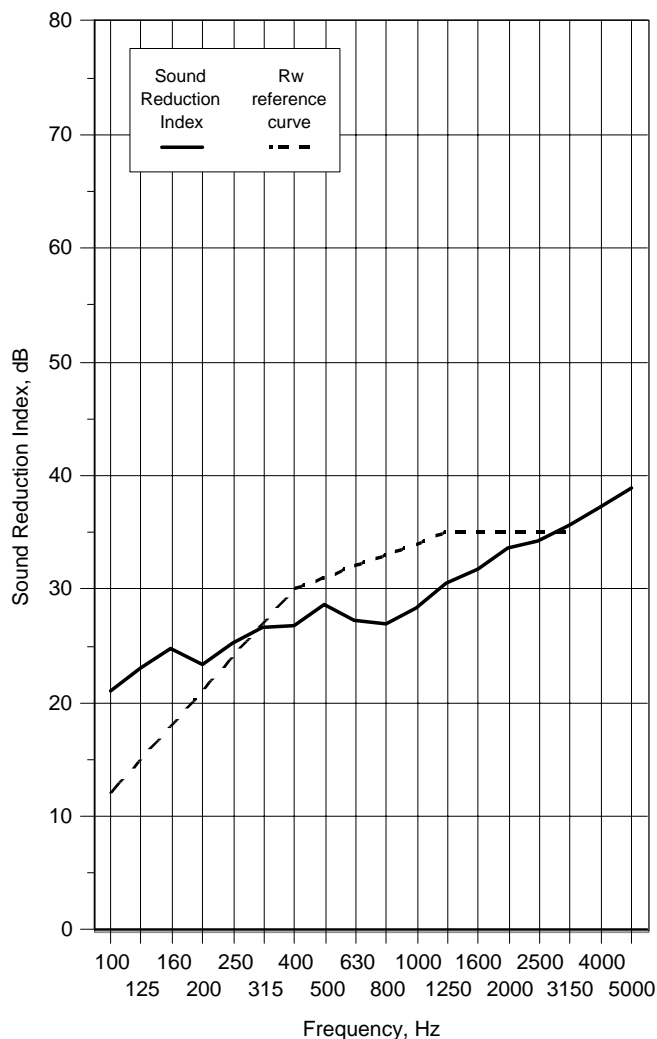

Rating according to BS EN ISO 717-1:1997

Rw(C;Ctr)= **31 (-1;-3) dB**

Notes * designates measurement corrected for background
 # designates limit of measurement due to background
 + designates frequency beyond standard and not UKAS accredited

v1.6

Test Number :	72	Air temperature:	16.7 °C
Client:	Norsound Ltd	Air humidity:	73 %
Test Date:	05/06/2008	Receiving room volume	300 m ³
Sample height:	2.115 m	Source room volume:	115 m ³
Sample width:	1.006 m	Sample weight:	17.3 kg/m ²
Product	Unequal Pair Flamebreak 430. Meeting stiles= 720		
Identification:	Threshold=810 / 810		
	Head, hanging jamb & closing jamb=710		

Freq f Hz	Sound Reduction Index, dB	
	1/3 Oct	1/1 Oct
50+	24.3	19.8
63+	23.8	
80+	16.3	
100	21.4	22.2
125	21.0	
160	25.2	
200	23.1	24.7
250	25.1	
315	26.5	
400	26.7	27.4
500	28.4	
630	27.2	
800	26.7	28.1
1000	28.0	
1250	30.4	
1600	31.8	32.9
2000	33.4	
2500	33.8	
3150	35.1	36.6
4000	36.8	
5000	38.7	
6300+	40.8	40.9
8000+	40.8	
10000+	41.2	
Average 100-3150	27.7	

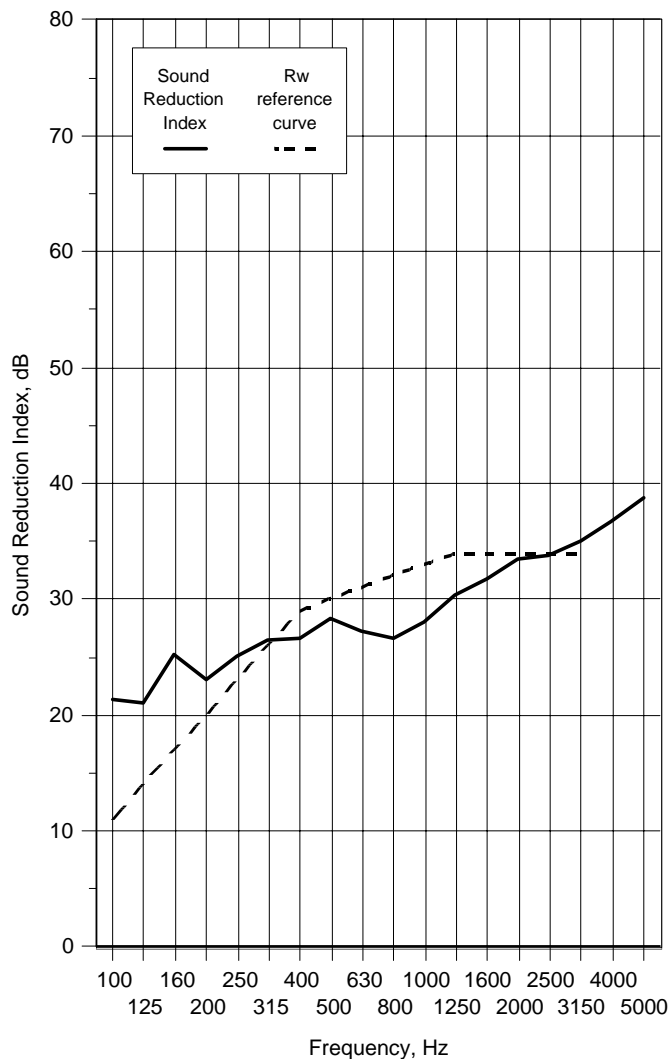

Rating according to BS EN ISO 717-1:1997

Rw(C;Ctr)= **30 (0;-2) dB**

Notes * designates measurement corrected for background

designates limit of measurement due to background

+ designates frequency beyond standard and not UKAS accredited

v1.6

Test Number :	73	Air temperature:	16.7 °C
Client:	Norsound Ltd	Air humidity:	74 %
Test Date:	05/06/2008	Receiving room volume	300 m3
Sample height:	2.115 m	Source room volume:	115 m3
Sample width:	1.006 m	Sample weight:	17.3 kg/m2
Product	Unequal Pair Flamebreak 430		
Identification:	Fully caulked		

Freq f Hz	Sound Reduction Index, dB	
	1/3 Oct	1/1 Oct
50+	22.8	21.6
63+	23.6	
80+	19.5	
100	21.6	22.3
125	22.9	
160	22.7	
200	22.3	24.2
250	24.7	
315	26.5	
400	27.5	28.3
500	29.1	
630	28.5	
800	28.3	30.0
1000	30.2	
1250	32.1	
1600	33.4	34.9
2000	35.4	
2500	36.6	
3150	38.1	39.7
4000	39.7	
5000	42.4	
6300+	44.8	44.4
8000+	44.7	
10000+	43.9 *	
Average 100-3150	28.7	

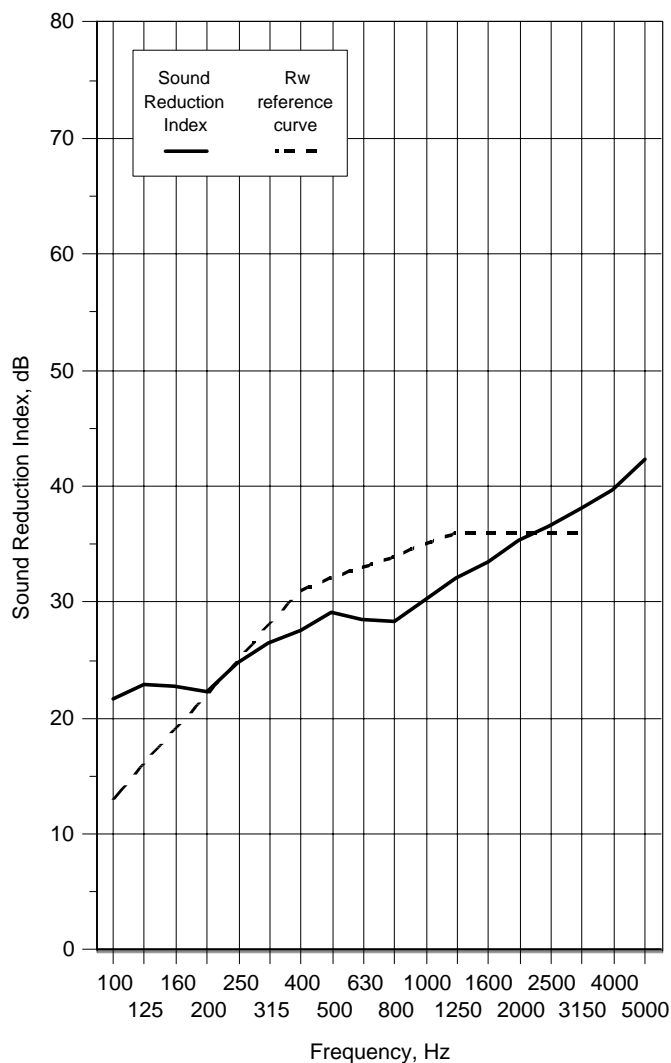

Rating according to BS EN ISO 717-1:1997

Rw(C;Ctr)= **32 (-1;-3)** dB

Notes * designates measurement corrected for background

designates limit of measurement due to background

+ designates frequency beyond standard and not UKAS accredited

v1.6

Test Number : 74 **Air temperature:** 17.1 °C
Client: Norsound Ltd **Air humidity:** 76 %
Test Date: 05/06/2008 **Receiving room volume** 300 m3
Sample height: 2.115 m **Source room volume:** 115 m3
Sample width: 1.006 m **Sample weight:** 26.3 kg/m2
Product Unequal Pair Strebord 44. Meeting Stiles=720+510
Identification: Threshold=810 / 810
 Head, hanging jamb & closing jamb=710.

Freq f Hz	Sound Reduction Index, dB	
	1/3 Oct	1/1 Oct
50+	27.1	24.3
63+	25.9	
80+	21.7	
100	25.0	25.0
125	23.6	
160	26.8	
200	28.2	30.0
250	30.9	
315	31.8	
400	30.8	32.0
500	32.9	
630	32.6	
800	30.8	29.7
1000	29.3	
1250	29.3	
1600	31.3	32.9
2000	33.3	
2500	34.7	
3150	36.0	36.4
4000	37.4	
5000	36.1	
6300+	38.2	38.9
8000+	38.3	
10000+	40.5	
Average 100-3150	30.5	

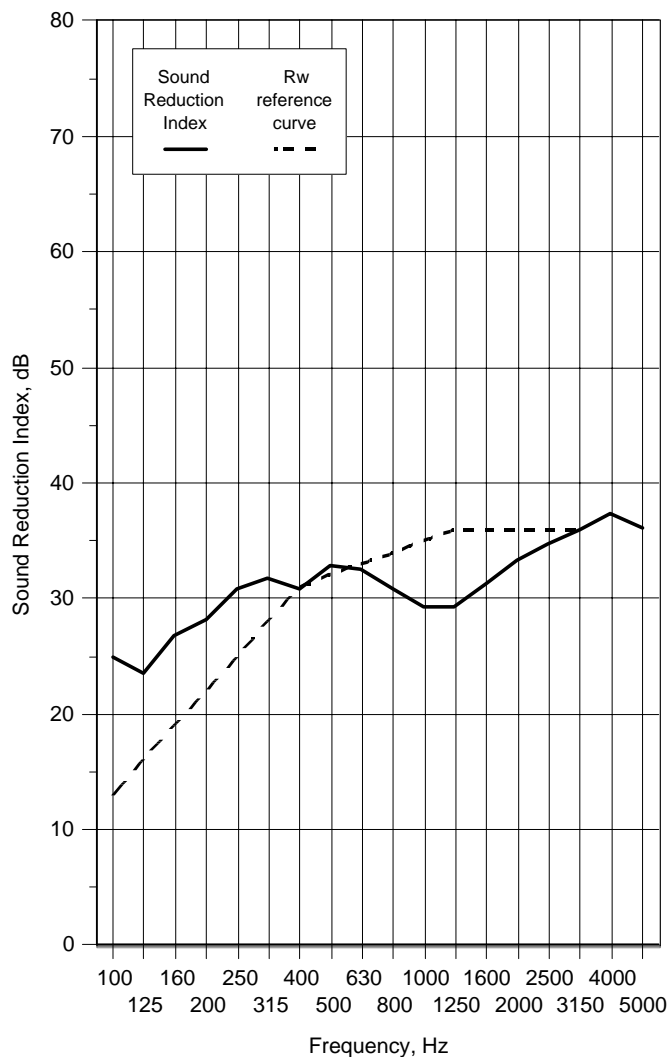

Rating according to BS EN ISO 717-1:1997

Rw(C;Ctr)= **32 (0;-1)** dB

Notes * designates measurement corrected for background
 # designates limit of measurement due to background
 + designates frequency beyond standard and not UKAS accredited

v1.6

Test Number : 75 **Air temperature:** 17.1 °C
Client: Norsound Ltd **Air humidity:** 76 %
Test Date: 05/06/2008 **Receiving room volume** 300 m3
Sample height: 2.115 m **Source room volume:** 115 m3
Sample width: 1.006 m **Sample weight:** 26.3 kg/m2
Product Unequal Pair Strebord 44. Meeting stiles=2x755 + 720
Identification: Threshold=810/810
 Head, hanging jamb & closing jamb=710

Freq f Hz	Sound Reduction Index, dB	
	1/3 Oct	1/1 Oct
50+	26.9	
63+	26.9	24.2
80+	21.4	
100	25.1	
125	23.7	25.3
160	28.0	
200	28.7	
250	31.1	30.4
315	32.1	
400	31.4	
500	33.3	32.5
630	33.2	
800	31.5	
1000	30.3	30.6
1250	30.1	
1600	31.8	
2000	33.3	33.1
2500	34.8	
3150	36.3	
4000	37.7	36.7
5000	36.4	
6300+	38.8	
8000+	39.2	39.6
10000+	41.0	
Average 100-3150	30.9	

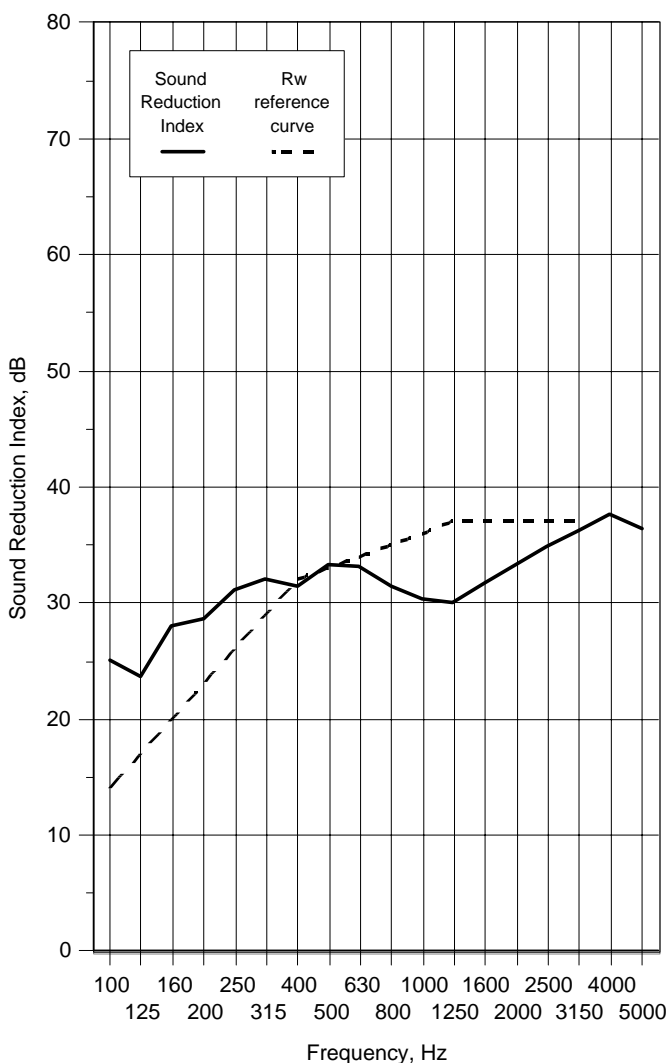

Rating according to BS EN ISO 717-1:1997

Rw(C;Ctr)= **33 (-1;-2) dB**

Notes * designates measurement corrected for background

designates limit of measurement due to background

+ designates frequency beyond standard and not UKAS accredited

v1.6

Test Number :	76	Air temperature:	17.2 °C
Client:	Norsound Ltd	Air humidity:	76 %
Test Date:	05/06/2008	Receiving room volume	300 m3
Sample height:	2.115 m	Source room volume:	115 m3
Sample width:	1.006 m	Sample weight:	26.3 kg/m2
Product	Unequal Pair Strebord 44. Meeting stiles=2x755		
Identification:	Threshold=810/810		
	Head, hanging jamb & closing jamb=710		

Freq f Hz	Sound Reduction Index, dB	
	1/3 Oct	1/1 Oct
50+	26.6	24.3
63+	25.8	
80+	22.1	
100	25.4	25.5
125	25.5	
160	25.7	
200	27.4	29.6
250	30.7	
315	32.1	
400	31.0	32.2
500	33.0	
630	32.8	
800	31.6	30.3
1000	29.9	
1250	29.7	
1600	30.7	32.0
2000	32.1	
2500	33.5	
3150	35.0	35.3
4000	36.2	
5000	34.9	
6300+	37.5	38.1
8000+	37.6	
10000+	39.7	
Average 100-3150	30.4	

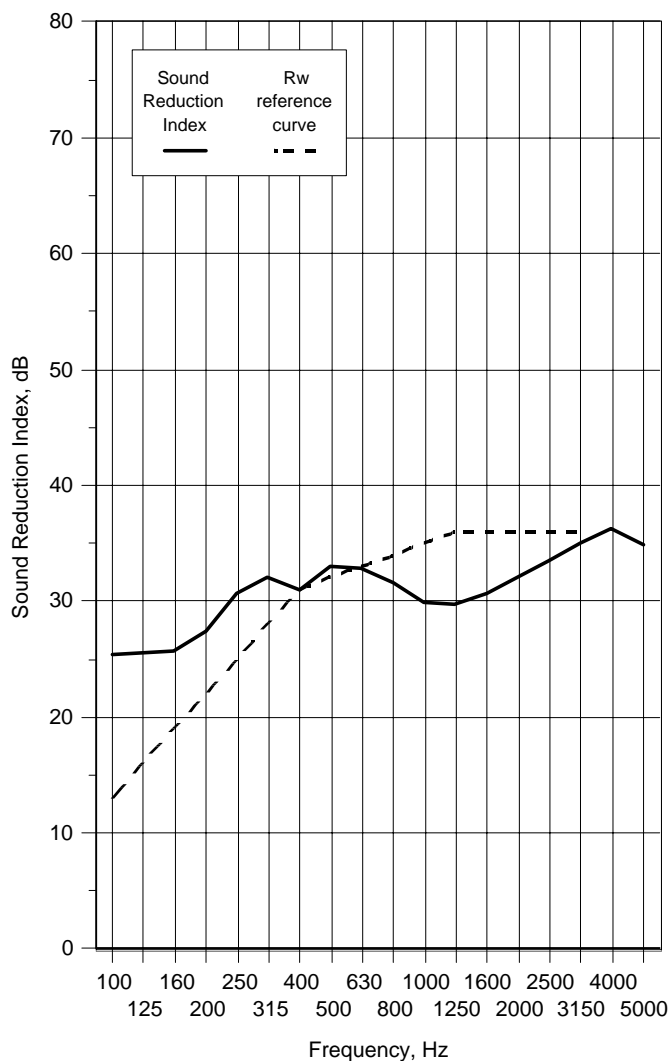

Rating according to BS EN ISO 717-1:1997

Rw(C;Ctr)= **32 (-1;-1)** dB

Notes * designates measurement corrected for background

designates limit of measurement due to background

+ designates frequency beyond standard and not UKAS accredited

v1.6

Test Number : 77 **Air temperature:** 17.2 °C
Client: Norsound Ltd **Air humidity:** 76 %
Test Date: 05/06/2008 **Receiving room volume:** 300 m³
Sample height: 2.115 m **Source room volume:** 115 m³
Sample width: 1.006 m **Sample weight:** 26.3 kg/m²
Product Unequal Pair Strebord 44. Meeting stiles=855 + 855 carrier only + 720
Identification: Threshold=810 / 810
 Head, hanging jamb & closing jamb=710

Freq f Hz	Sound Reduction Index, dB	
	1/3 Oct	1/1 Oct
50+	27.2	23.7
63+	25.1	
80+	21.1	
100	24.7	25.4
125	24.4	
160	27.6	30.7
200	29.2	
250	31.3	
315	32.3	32.4
400	31.1	
500	33.4	30.5
630	33.0	
800	31.5	
1000	30.2	32.9
1250	29.9	
1600	31.5	
2000	33.2	36.5
2500	34.7	
3150	35.7	
4000	37.4	39.6
5000	36.4	
6300+	38.8	
8000+	39.2	41.2
10000+	41.2	
Average 100-3150	30.9	

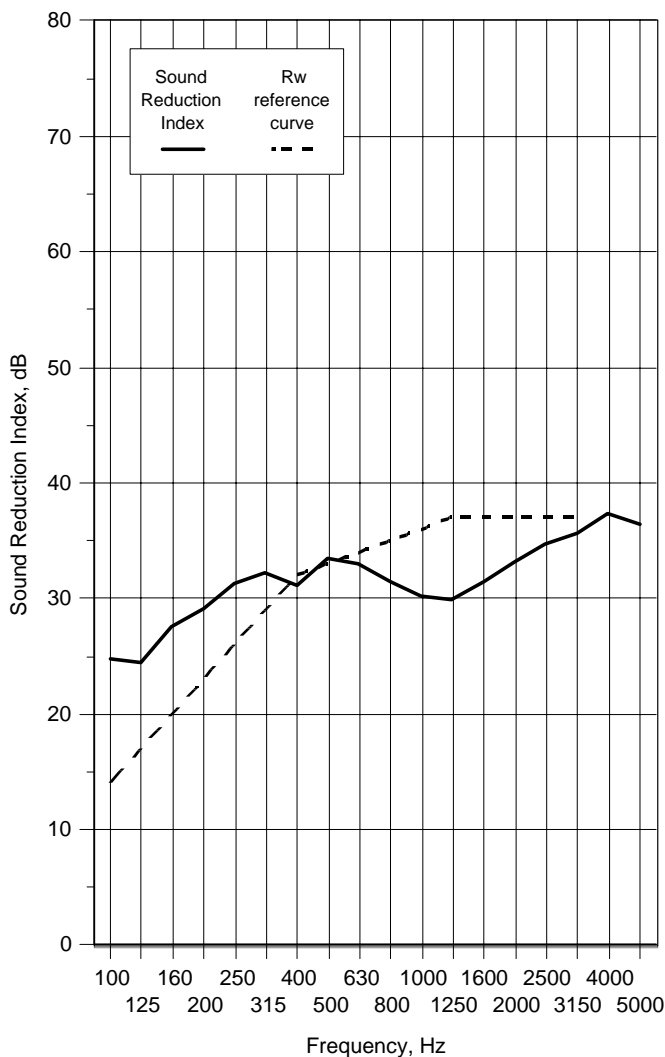

Rating according to BS EN ISO 717-1:1997

Rw(C;Ctr)= **33 (-1;-2) dB**

Notes * designates measurement corrected for background
 # designates limit of measurement due to background
 + designates frequency beyond standard and not UKAS accredited

v1.6

Test Number : 78 **Air temperature:** 17.3 °C
Client: Norsound Ltd **Air humidity:** 76 %
Test Date: 05/06/2008 **Receiving room volume** 300 m3
Sample height: 2.115 m **Source room volume:** 115 m3
Sample width: 1.006 m **Sample weight:** 19.3 kg/m2
Product Single leaf Flamebreak FF630
Identification: Threshold=810
 Head, hanging jamb & closing jamb=710

Freq f Hz	Sound Reduction Index, dB	
	1/3 Oct	1/1 Oct
50+	10.3	12.4
63+	13.1	
80+	15.1	
100	19.1	20.8
125	20.4	
160	24.3	
200	21.5	24.1
250	25.4	
315	27.8	
400	27.0	27.8
500	28.3	
630	28.4	
800	26.2	26.3
1000	25.5	
1250	27.3	
1600	29.6	31.1
2000	31.5	
2500	32.9	
3150	34.1	35.8
4000	36.1	
5000	37.9	
6300+	39.3	38.8
8000+	37.9	
10000+	39.5	
Average 100-3150	26.8	

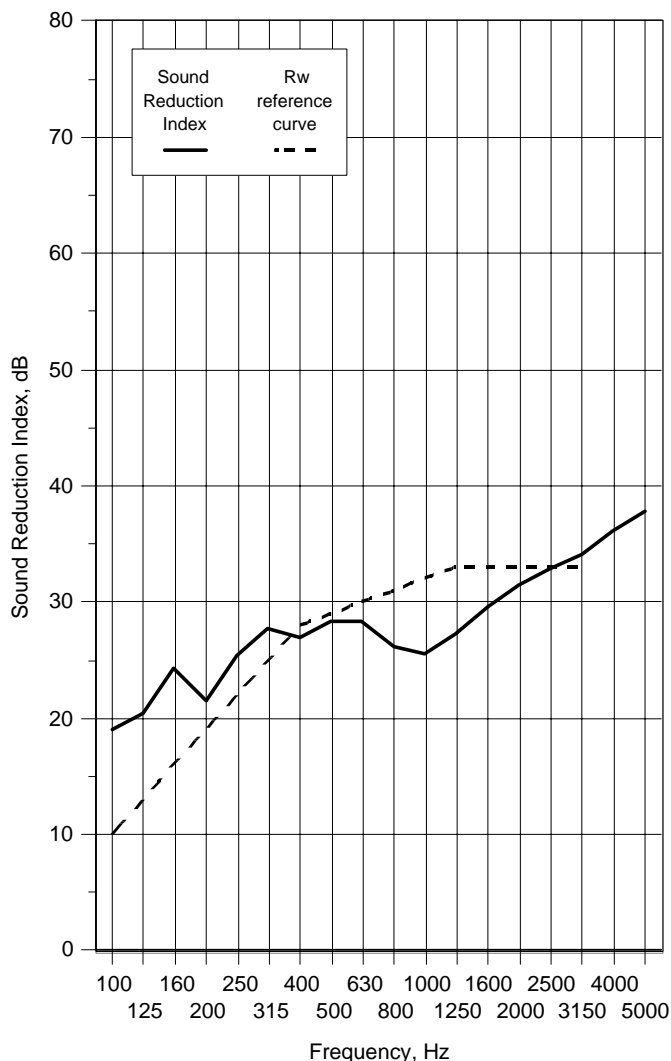

Rating according to BS EN ISO 717-1:1997

Rw(C;Ctr)= **29 (-1;-2)** dB

Notes * designates measurement corrected for background

designates limit of measurement due to background

+ designates frequency beyond standard and not UKAS accredited

v1.6

Test Number :	79	Air temperature:	17.3 °C
Client:	Norsound Ltd	Air humidity:	76 %
Test Date:	05/06/2008	Receiving room volume	300 m3
Sample height:	2.115 m	Source room volume:	115 m3
Sample width:	1.006 m	Sample weight:	19.3 kg/m2
Product	Single leaf Flamebreak FF630		
Identification:	Fully caulked		

Freq f Hz	Sound Reduction Index, dB	
	1/3 Oct	1/1 Oct
50+	18.7	16.1
63+	15.5	
80+	15.0	
100	17.8	20.1
125	20.7	
160	24.2	24.0
200	21.8	
250	24.7	
315	27.6	28.1
400	27.1	
500	28.7	
630	28.8	27.4
800	27.2	
1000	26.6	
1250	28.6	32.2
1600	30.5	
2000	32.6	
2500	34.3	37.4
3150	35.9	
4000	37.9	
5000	39.2	39.8
6300+	40.6	
8000+	38.8	
10000+	40.2	
Average 100-3150	27.3	

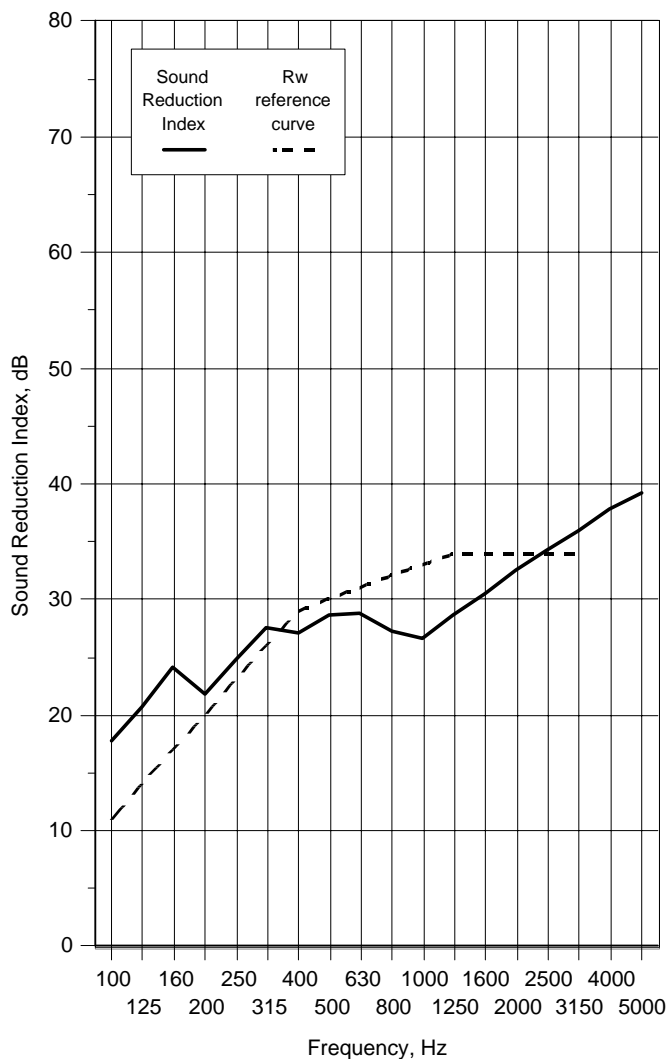

Rating according to BS EN ISO 717-1:1997

Rw(C;Ctr)= **30 (-1;-3)** dB

Notes * designates measurement corrected for background
 # designates limit of measurement due to background
 + designates frequency beyond standard and not UKAS accredited

v1.6

Test Number :	81	Air temperature:	16.3 °C
Client:	Norsound Ltd	Air humidity:	74 %
Test Date:	06/06/2008	Receiving room volume	300 m3
Sample height:	2.115 m	Source room volume:	115 m3
Sample width:	1.006 m	Sample weight:	19.3 kg/m2
Product	Single leaf Flamebreak FF630		
Identification:	Threshold=810		
	Head, hanging jamb & closing jamb=710		

Freq f Hz	Sound Reduction Index, dB	
	1/3 Oct	1/1 Oct
50+	11.0	12.9
63+	14.1	
80+	14.3	
100	18.0	19.8
125	19.4	
160	24.0	
200	21.2	23.6
250	24.4	
315	27.1	
400	27.4	28.0
500	28.7	
630	28.1	
800	26.1	26.1
1000	25.3	
1250	27.2	
1600	29.5	31.1
2000	31.6	
2500	32.7	
3150	34.3	35.4
4000	35.3	
5000	37.0	
6300+	38.8	38.7
8000+	38.0	
10000+	39.3	
Average 100-3150	26.6	

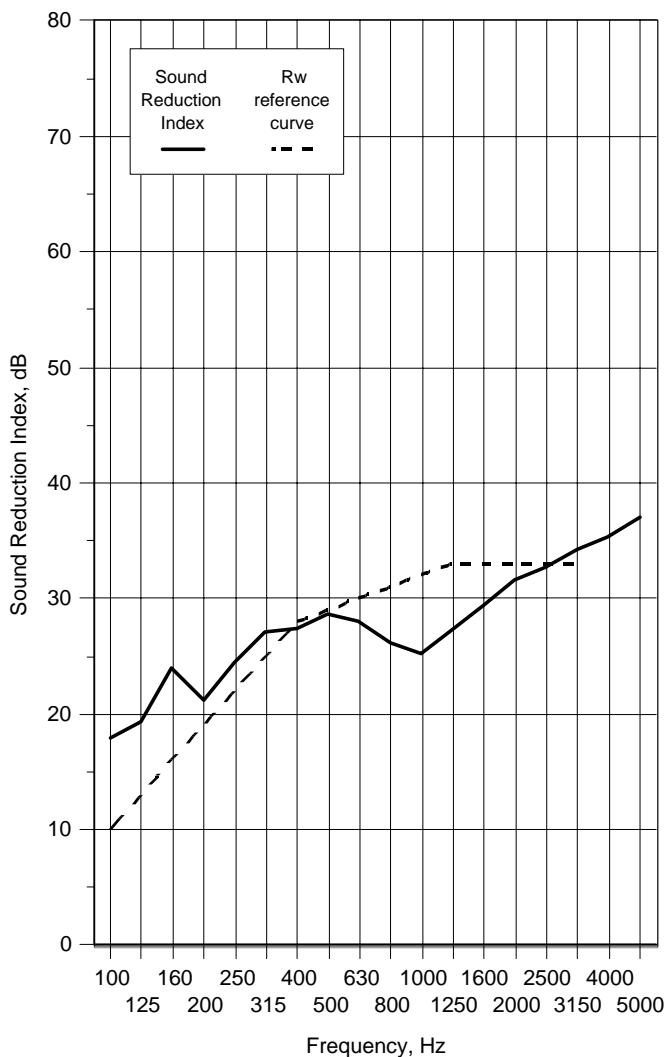

Rating according to BS EN ISO 717-1:1997

Rw(C;Ctr)= **29 (-1;-3)** dB

Notes * designates measurement corrected for background

designates limit of measurement due to background

+ designates frequency beyond standard and not UKAS accredited

v1.6

Test Number : 82 **Air temperature:** 16.6 °C
Client: Norsound Ltd **Air humidity:** 78 %
Test Date: 06/06/2008 **Receiving room volume** 300 m3
Sample height: 2.115 m **Source room volume:** 115 m3
Sample width: 1.006 m **Sample weight:** 29.3 kg/m2
Product Unequal Pair Flamebreak 660. Meeting stiles=720+510
Identification: Threshold=810/ 810
 Head, hanging jamb & closing jamb=710

Freq f Hz	Sound Reduction Index, dB	
	1/3 Oct	1/1 Oct
50+	26.2	23.5
63+	25.6	
80+	20.8	
100	24.9	25.4
125	24.1	
160	28.4	
200	25.4	26.7
250	26.7	
315	28.5	
400	30.1	30.6
500	31.0	
630	30.9	
800	30.6	31.9
1000	32.0	
1250	33.6	
1600	35.4	37.3
2000	38.4	
2500	39.0	
3150	39.4	41.1
4000	41.5	
5000	43.5	
6300+	46.1	45.4
8000+	45.8	
10000+	44.5	
Average 100-3150	31.2	

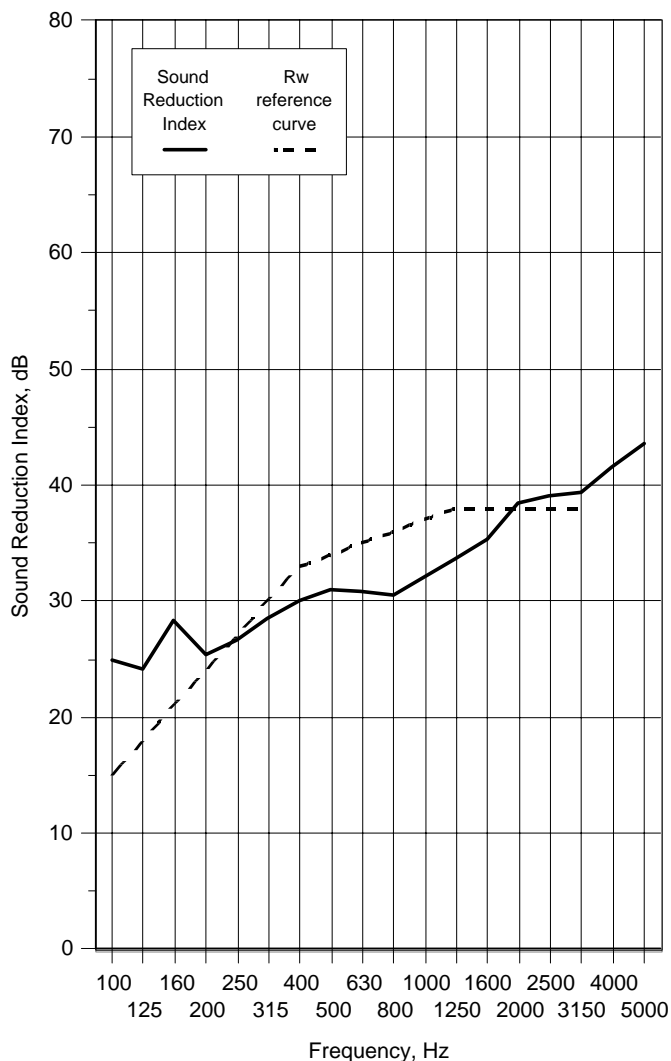

Rating according to BS EN ISO 717-1:1997

Rw(C;Ctr)= **34 (-1;-3)** dB

Notes * designates measurement corrected for background

designates limit of measurement due to background

+ designates frequency beyond standard and not UKAS accredited

v1.6

Test Number : 83
Client: Norsound Ltd
Test Date: 06/06/2008
Sample height: 2.115 m
Sample width: 1.006 m
Product Unequal Pair Flamebreak 660. Meeting stiles=510
Identification: Threshold=810/ 810
 Head, hanging jamb & closing jamb=710

Air temperature: 16.7 °C
Air humidity: 78 %
Receiving room volume 300 m3
Source room volume: 115 m3
Sample weight: 29.3 kg/m2

Freq f Hz	Sound Reduction Index, dB	
	1/3 Oct	1/1 Oct
50+	27.5	24.9
63+	27.2	
80+	22.2	
100	25.4	26.0
125	24.6	
160	29.4	
200	27.3	27.9
250	27.8	
315	28.7	
400	30.4	30.4
500	30.6	
630	30.2	
800	29.8	31.0
1000	31.2	
1250	32.3	
1600	32.8	34.7
2000	35.3	
2500	36.9	
3150	38.1	39.5
4000	40.6	
5000	40.3	
6300+	43.7	43.7
8000+	43.8	
10000+	43.7	
Average 100-3150	30.7	

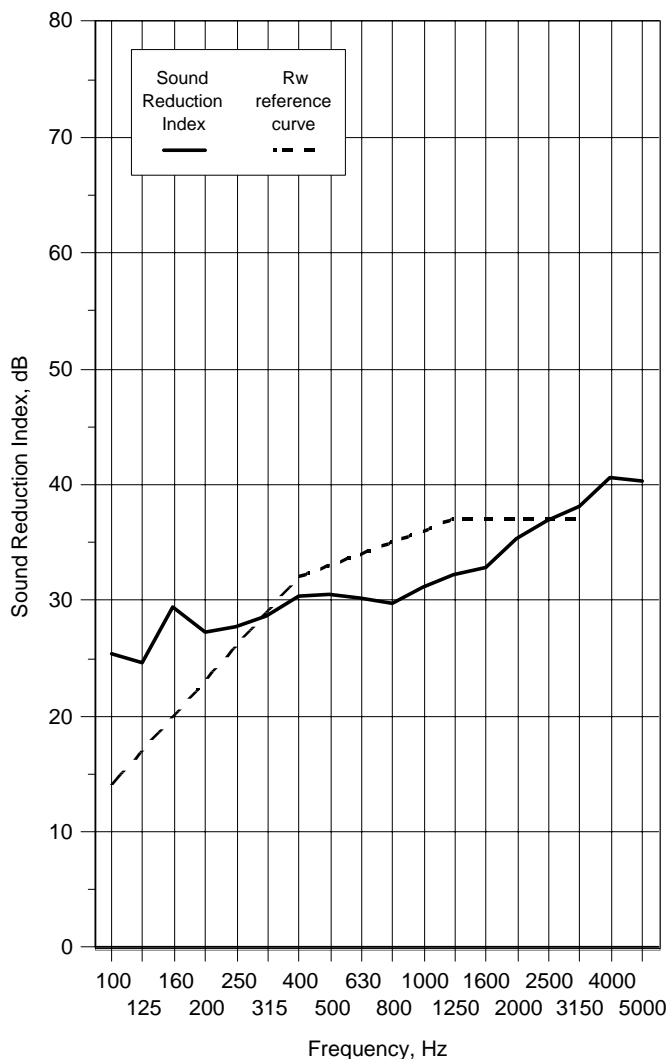

Rating according to BS EN ISO 717-1:1997

Rw(C;Ctr)= **33 (-1;-2)** dB

Notes * designates measurement corrected for background
 # designates limit of measurement due to background
 + designates frequency beyond standard and not UKAS accredited

v1.6

Test Number : 84 **Air temperature:** 16.8 °C
Client: Norsound Ltd **Air humidity:** 78 %
Test Date: 06/06/2008 **Receiving room volume** 300 m³
Sample height: 2.115 m **Source room volume:** 115 m³
Sample width: 1.006 m **Sample weight:** 29.3 kg/m²
Product Unequal Pair Flamebreak 660. Meeting stiles=2x755+720
Identification: Threshold=810/ 810
 Head, hanging jamb & closing jamb=710

Freq f Hz	Sound Reduction Index, dB	
	1/3 Oct	1/1 Oct
50+	27.8	24.3
63+	26.7	
80+	21.4	
100	24.5	25.7
125	24.9	
160	29.3	26.9
200	25.8	
250	26.8	
315	28.5	30.9
400	30.2	
500	31.2	
630	31.2	32.5
800	31.1	
1000	32.6	
1250	34.3	37.0
1600	35.8	
2000	37.9	
2500	37.7	41.2
3150	39.0	
4000	42.2	
5000	43.9	46.1
6300+	45.9	
8000+	46.6	
10000+	45.9	
Average 100-3150	31.3	

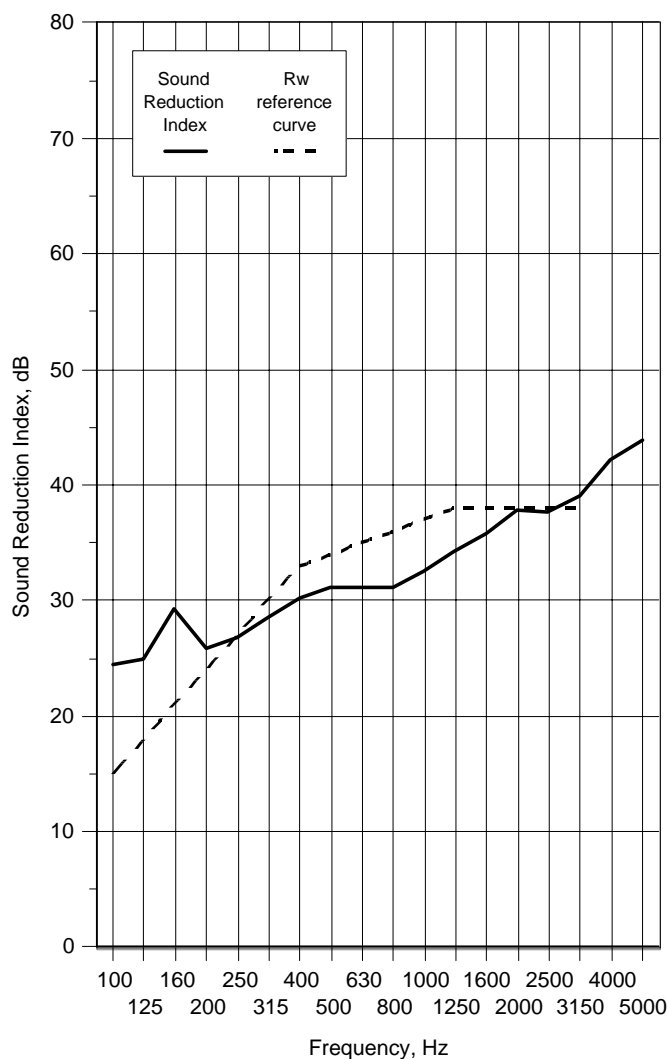

Rating according to BS EN ISO 717-1:1997

Rw(C;Ctr)= **34 (-1;-3) dB**

Notes * designates measurement corrected for background

designates limit of measurement due to background

+ designates frequency beyond standard and not UKAS accredited

v1.6

Test Number :	85	Air temperature:	16.9 °C
Client:	Norsound Ltd	Air humidity:	78 %
Test Date:	06/06/2008	Receiving room volume	300 m3
Sample height:	2.115 m	Source room volume:	115 m3
Sample width:	1.006 m	Sample weight:	29.3 kg/m2
Product	Unequal Pair Flamebreak 660		
Identification:	Meeting stiles=855+855 carrier only+720		
	Threshold=810/ 810		
	Head, hanging jamb & closing jamb=710		

Freq f Hz	Sound Reduction Index, dB	
	1/3 Oct	1/1 Oct
50+	27.2	24.3
63+	26.9	
80+	21.4	25.4
100	24.5	
125	24.1	
160	29.1	26.9
200	25.8	
250	26.9	
315	28.3	
400	30.3	30.8
500	31.3	
630	31.0	
800	31.0	
1000	32.6	
1250	34.2	32.4
1600	35.7	
2000	37.6	
2500	37.3	36.8
3150	38.0	
4000	41.8	
5000	43.7	
6300+	45.6	40.5
8000+	46.2	
10000+	45.8	
Average 100-3150	31.1	

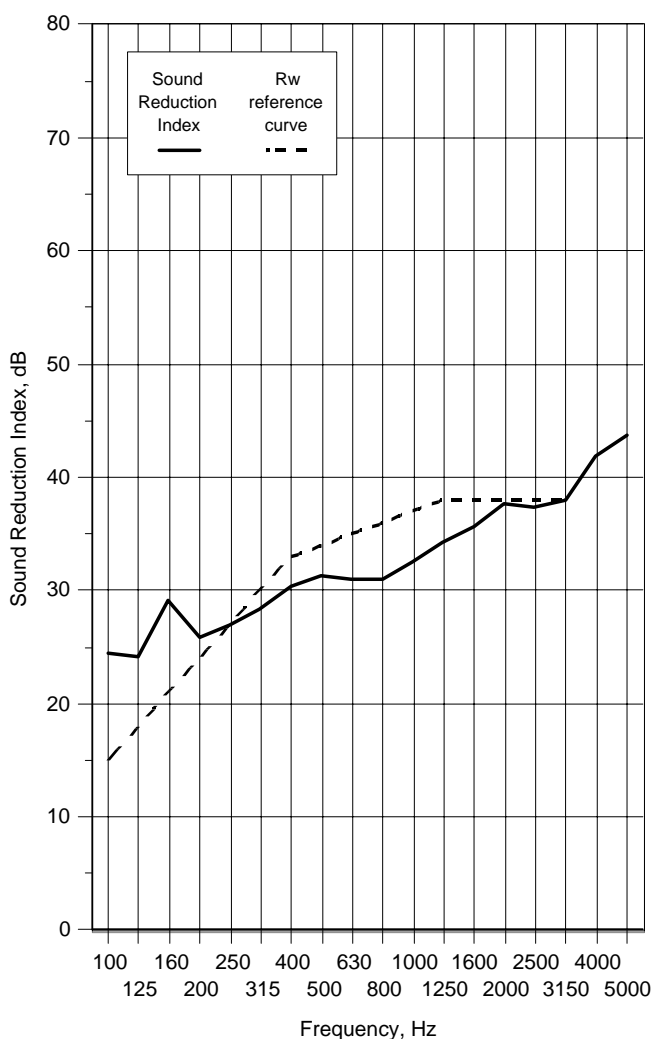

Rating according to BS EN ISO 717-1:1997

Rw(C;Ctr)= **34 (-1;-3) dB**

Notes * designates measurement corrected for background
 # designates limit of measurement due to background
 + designates frequency beyond standard and not UKAS accredited

v1.6

Test Number :	86	Air temperature:	16.9 °C
Client:	Norsound Ltd	Air humidity:	79 %
Test Date:	06/06/2008	Receiving room volume	300 m3
Sample height:	2.115 m	Source room volume:	115 m3
Sample width:	1.006 m	Sample weight:	31.4 kg/m2
Product	Unequal Pair Strebord 54. Meeting stiles=720+510		
Identification:	Threshold=810/810		
	Head, hanging jamb & closing jamb=710		

Freq f Hz	Sound Reduction Index, dB	
	1/3 Oct	1/1 Oct
50+	26.5	23.9
63+	25.0	
80+	21.7	
100	24.5	25.4
125	24.6	
160	28.0	
200	28.6	30.1
250	30.4	
315	32.2	
400	32.9	33.6
500	34.0	
630	33.8	
800	31.4	30.4
1000	29.5	
1250	30.4	
1600	31.7	33.0
2000	33.6	
2500	34.3	
3150	34.2	35.4
4000	35.3	
5000	37.4	
6300+	40.0	41.5
8000+	41.5	
10000+	43.8	
Average 100-3150	30.9	

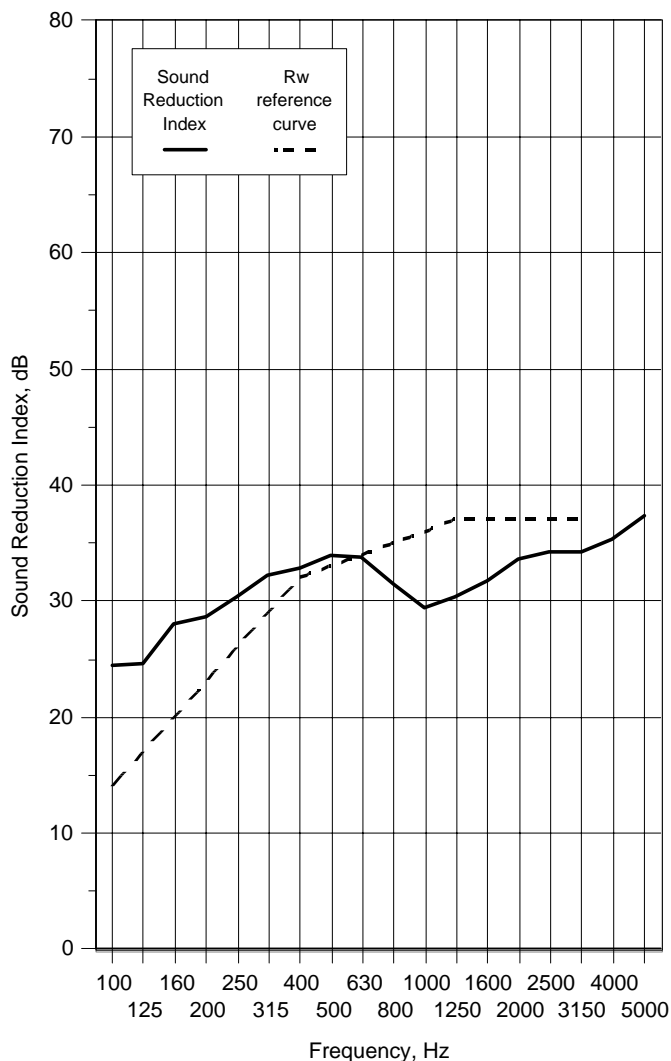

Rating according to BS EN ISO 717-1:1997

Rw(C;Ctr)= **33 (-1;-2) dB**

Notes * designates measurement corrected for background

designates limit of measurement due to background

+ designates frequency beyond standard and not UKAS accredited

v1.6

Test Number : 87 **Air temperature:** 16.9 °C
Client: Norsound Ltd **Air humidity:** 81 %
Test Date: 06/06/2008 **Receiving room volume** 300 m³
Sample height: 2.115 m **Source room volume:** 115 m³
Sample width: 2.115 m **Sample weight:** 31.4 kg/m²
Product Unequal Pair Strebord 54. Meeting stiles=855+855 carrier only+720
Identification: Threshold=810/810
 Head, hanging jamb & closing jamb=710

Freq f Hz	Sound Reduction Index, dB	
	1/3 Oct	1/1 Oct
50+	26.4	24.0
63+	25.4	
80+	21.7	
100	24.5	25.4
125	24.4	
160	28.3	30.1
200	28.5	
250	30.5	
315	32.1	33.4
400	32.7	
500	33.9	30.4
630	33.7	
800	31.5	
1000	29.5	33.1
1250	30.3	
1600	31.8	35.5
2000	33.5	
2500	34.4	
3150	34.2	41.6
4000	35.3	
5000	37.7	43.8
6300+	40.1	
8000+	41.5	
10000+	43.8	
Average 100-3150	30.9	

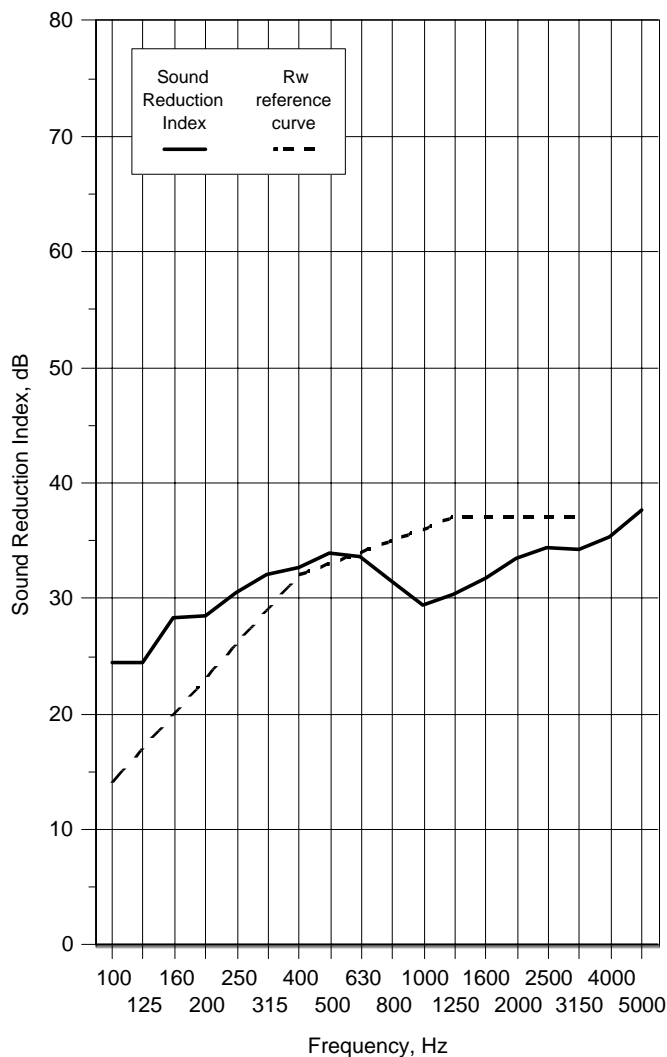

Rating according to BS EN ISO 717-1:1997

Rw(C;Ctr)= **33 (-1;-2)** dB

Notes * designates measurement corrected for background

designates limit of measurement due to background

+ designates frequency beyond standard and not UKAS accredited

v1.6

Test Number : 88 **Air temperature:** 16.9 °C
Client: Norsound Ltd **Air humidity:** 81 %
Test Date: 06/06/2008 **Receiving room volume** 300 m3
Sample height: 2.115 m **Source room volume:** 115 m3
Sample width: 1.006 m **Sample weight:** 31.4 kg/m2
Product Unequal Pair Strebord 54. Meeting stiles=2x755+720
Identification: Threshold=810+810
 Head, hanging jamb & closing jamb=710

Freq f Hz	Sound Reduction Index, dB	
	1/3 Oct	1/1 Oct
50+	26.2	23.8
63+	25.2	
80+	21.5	
100	25.0	25.6
125	24.5	
160	28.2	
200	28.5	30.1
250	30.6	
315	32.0	
400	33.0	33.6
500	34.0	
630	33.8	
800	31.7	30.5
1000	29.6	
1250	30.4	
1600	31.8	33.2
2000	33.7	
2500	34.5	
3150	34.3	35.6
4000	35.4	
5000	37.9	
6300+	40.7	42.1
8000+	42.0	
10000+	44.2	
Average 100-3150	31.0	

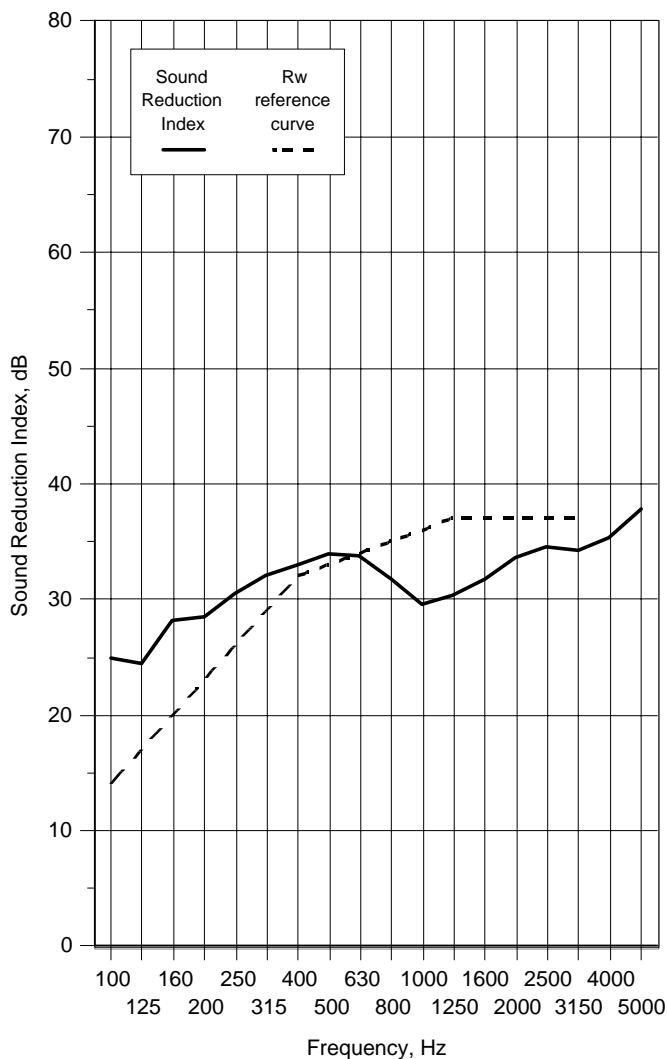

Rating according to BS EN ISO 717-1:1997

Rw(C;Ctr)= **33 (-1;-2)** dB

Notes * designates measurement corrected for background

designates limit of measurement due to background

+ designates frequency beyond standard and not UKAS accredited

v1.6

Test Number : 89 **Air temperature:** 17 °C
Client: Norsound Ltd **Air humidity:** 80 %
Test Date: 06/06/2008 **Receiving room volume** 300 m3
Sample height: 2.115 m **Source room volume:** 115 m3
Sample width: 1.006 m **Sample weight:** 31.4 kg/m2
Product Unequal Pair Strebord 54. Meeting stiles=720+710
Identification: Threshold=810/810
 Head, hanging jamb & closing jamb=710

Freq f Hz	Sound Reduction Index, dB	
	1/3 Oct	1/1 Oct
50+	26.2	23.7
63+	25.2	
80+	21.3	
100	24.6	25.5
125	24.8	
160	27.9	
200	28.3	29.9
250	30.4	
315	31.9	
400	32.8	33.4
500	33.9	
630	33.7	
800	31.3	30.2
1000	29.4	
1250	30.2	
1600	31.5	32.9
2000	33.3	
2500	34.2	
3150	34.0	35.2
4000	35.0	
5000	37.3	
6300+	40.0	41.4
8000+	41.3	
10000+	43.5	
Average 100-3150	30.8	

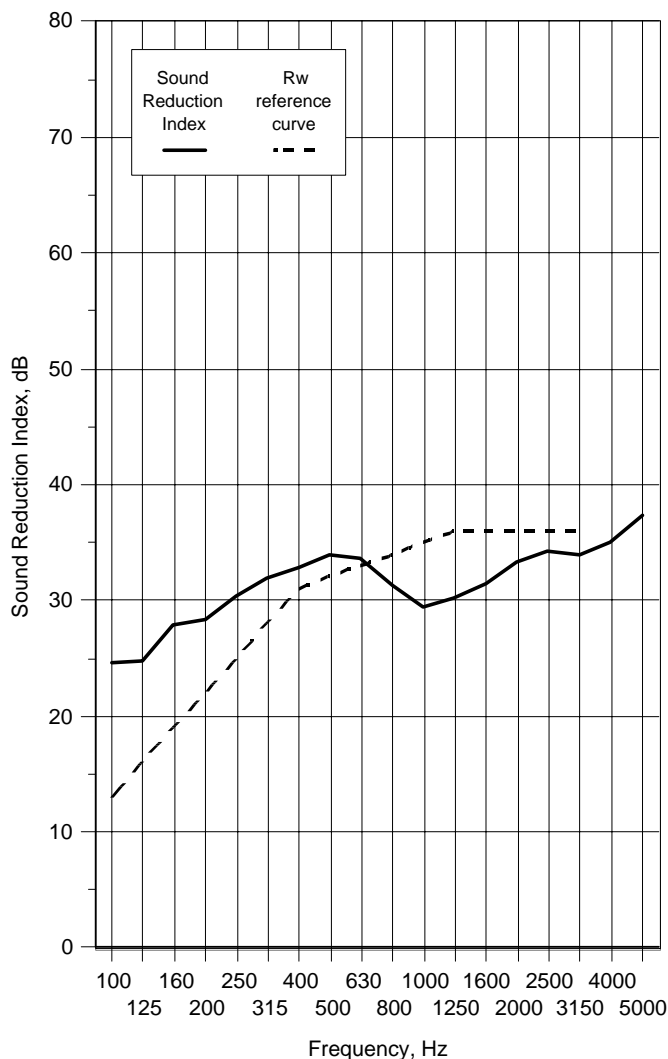

Rating according to BS EN ISO 717-1:1997

Rw(C;Ctr)= **32 (0;-1) dB**

Notes * designates measurement corrected for background

designates limit of measurement due to background

+ designates frequency beyond standard and not UKAS accredited

v1.6

Test Number :	90	Air temperature:	17 °C
Client:	Norsound Ltd	Air humidity:	80 %
Test Date:	06/06/2008	Receiving room volume	300 m3
Sample height:	2.115 m	Source room volume:	115 m3
Sample width:	1.006 m	Sample weight:	31.4 kg/m2
Product	Unequal Pair Strebord 54. Meeting stiles= 710		
Identification:	Threshold=810/810		
	Head, hanging jamb & closing jamb=710		

Freq f Hz	Sound Reduction Index, dB	
	1/3 Oct	1/1 Oct
50+	26.2	
63+	26.6	23.8
80+	21.1	
100	24.3	
125	25.3	25.7
160	28.7	
200	28.0	
250	30.2	29.7
315	31.5	
400	32.7	
500	33.6	33.2
630	33.5	
800	31.0	
1000	28.8	29.5
1250	29.1	
1600	29.7	
2000	31.0	31.0
2500	32.6	
3150	33.3	
4000	34.5	34.3
5000	35.4	
6300+	38.4	
8000+	39.3	39.6
10000+	41.7	
Average 100-3150	30.2	

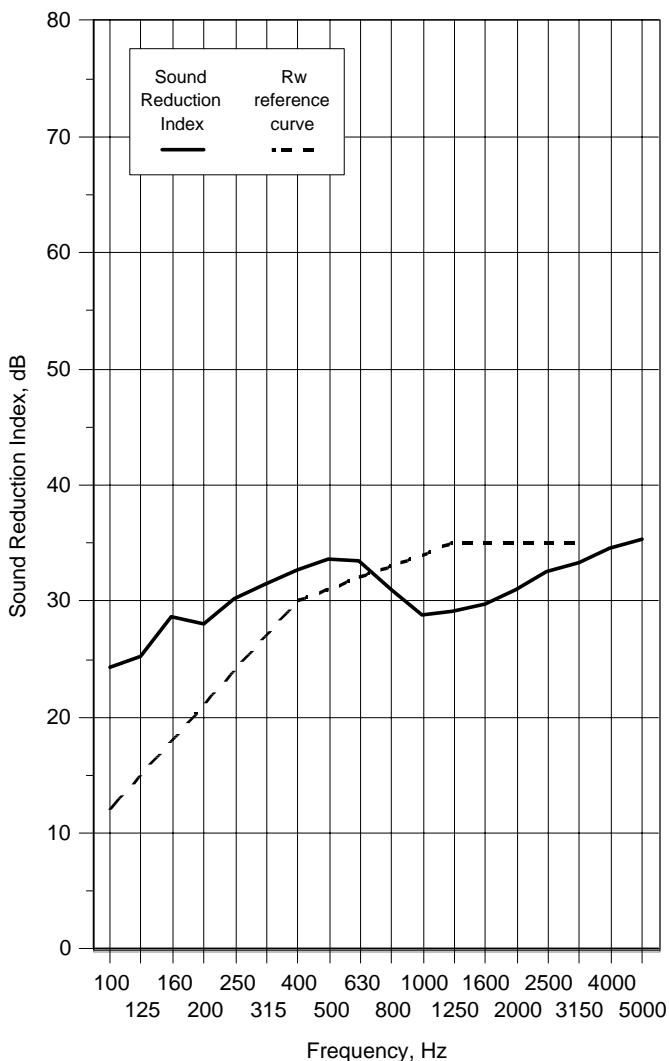

Rating according to BS EN ISO 717-1:1997

Rw(C;Ctr)= **31 (0;-1) dB**

Notes * designates measurement corrected for background

designates limit of measurement due to background

+ designates frequency beyond standard and not UKAS accredited

v1.6

Test Number :	91	Air temperature:	17 °C
Client:	Norsound Ltd	Air humidity:	80 %
Test Date:	06/06/2008	Receiving room volume	300 m3
Sample height:	2.115 m	Source room volume:	115 m3
Sample width:	1.006 m	Sample weight:	31.4 kg/m2
Product	Unequal Pair Strebord 54		
Identification:	Fully caulked		

Freq f Hz	Sound Reduction Index, dB	
	1/3 Oct	1/1 Oct
50+	24.5	23.5
63+	25.5	
80+	21.4	
100	24.1	25.7
125	25.1	
160	29.5	
200	29.0	30.5
250	30.9	
315	32.5	
400	34.3	34.7
500	35.0	
630	34.9	
800	32.9	31.7
1000	30.8	
1250	31.6	
1600	33.4	34.8
2000	34.9	
2500	36.7	
3150	36.0	37.2
4000	36.7	
5000	39.7	
6300+	42.6	44.3
8000+	44.3	
10000+	47.1	
Average 100-3150	32.0	

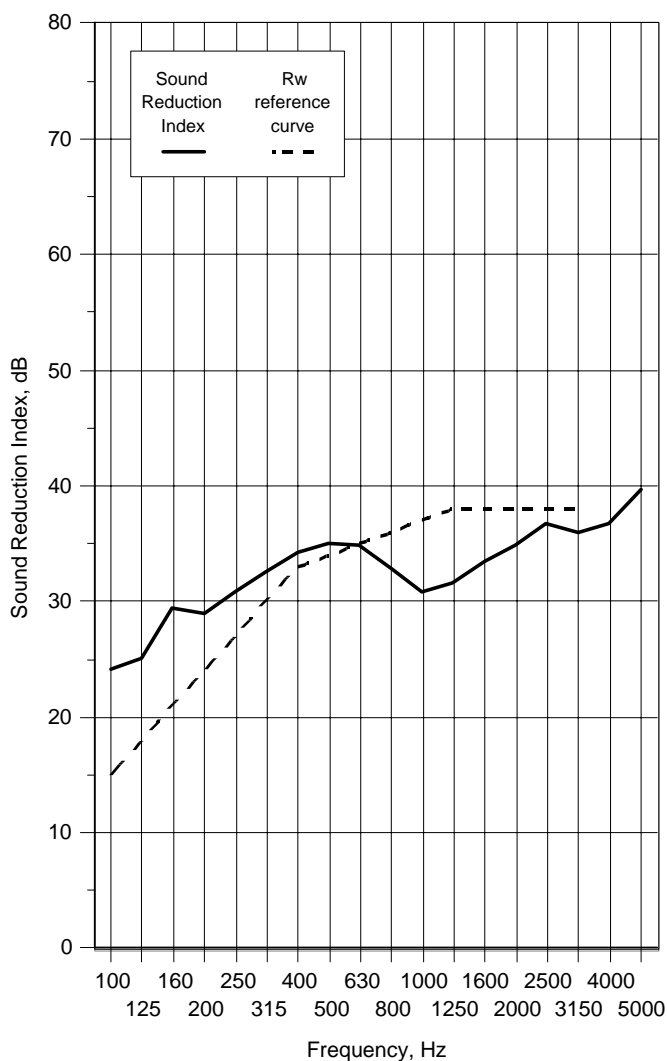

Rating according to BS EN ISO 717-1:1997

Rw(C;Ctr)= **34 (-1;-2) dB**

Notes * designates measurement corrected for background
 # designates limit of measurement due to background
 + designates frequency beyond standard and not UKAS accredited

v1.6

Test Number :	92	Air temperature:	16.9 °C
Client:	Norsound Ltd	Air humidity:	79 %
Test Date:	06/06/2008	Receiving room volume	300 m3
Sample height:	2.115 m	Source room volume:	115 m3
Sample width:	1.006 m	Sample weight:	44.4 kg/m2
Product	Single leaf AudioCore		
Identification:	Fully caulked		

Freq f Hz	Sound Reduction Index, dB	
	1/3 Oct	1/1 Oct
50+	22.4	23.1
63+	24.7	
80+	22.4	
100	25.3	27.4
125	27.1	
160	32.4	
200	31.9	33.5
250	33.8	
315	35.8	
400	37.4	38.2
500	38.6	
630	38.7	
800	39.5	40.5
1000	40.4	
1250	42.1	
1600	44.9	47.6
2000	49.6	
2500	50.9	
3150	51.5	53.1
4000	53.2 *	
5000	55.5 *	
6300+	57.3 *	58.2
8000+	58.2 *	
10000+	59.3 *	
Average 100-3150	38.7	

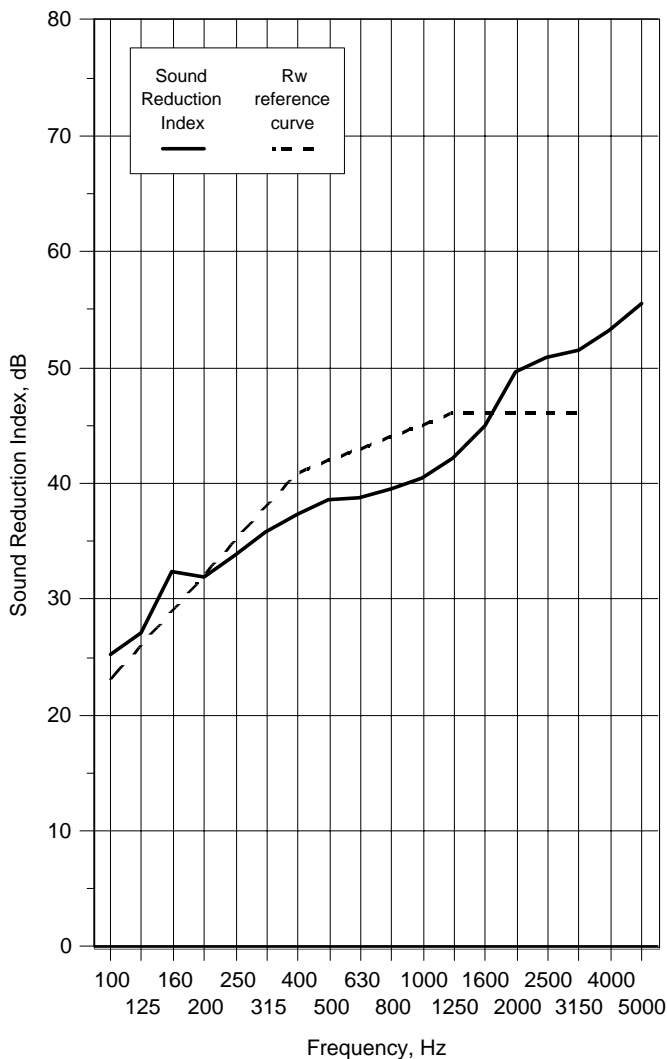

Rating according to BS EN ISO 717-1:1997

Rw(C;Ctr)= **42 (-1;-4)** dB

Notes * designates measurement corrected for background
 # designates limit of measurement due to background
 + designates frequency beyond standard and not UKAS accredited

v1.6

Test Number :	93	Air temperature:	16.9 °C
Client:	Norsound Ltd	Air humidity:	79 %
Test Date:	06/06/2008	Receiving room volume	300 m3
Sample height:	2.115 m	Source room volume:	115 m3
Sample width:	1.006 m	Sample weight:	44.4 kg/m2
Product	Single leaf AudioCore		
Identification:	Threshold=850		
	Head, hanging jamb & closing jamb=710		

Freq f Hz	Sound Reduction Index, dB	
	1/3 Oct	1/1 Oct
50+	22.8	22.9
63+	24.3	
80+	21.9	
100	25.4	27.2
125	26.9	
160	31.0	
200	31.3	32.7
250	32.7	
315	34.6	
400	36.3	36.8
500	37.3	
630	36.8	
800	37.0	35.8
1000	36.0	
1250	34.9	
1600	33.5	35.0
2000	35.6	
2500	36.3	
3150	36.4	38.7
4000	39.6	
5000	41.9	
6300+	45.2	45.7
8000+	46.7	
10000+	45.3	
Average 100-3150	33.9	

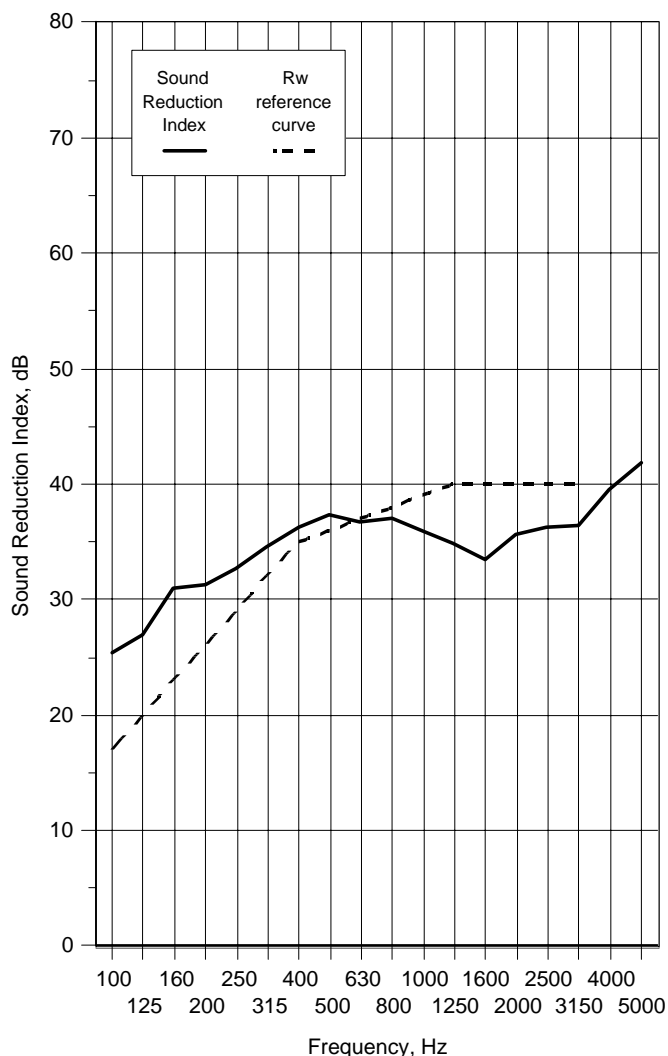

Rating according to BS EN ISO 717-1:1997

Rw(C;Ctr)= **36 (-1;-1) dB**

Notes * designates measurement corrected for background

designates limit of measurement due to background

+ designates frequency beyond standard and not UKAS accredited

v1.6

Test Number :	95	Air temperature:	16.7 °C
Client:	Norsound Ltd	Air humidity:	69 %
Test Date:	09/06/2008	Receiving room volume	300 m3
Sample height:	2.115 m	Source room volume:	115 m3
Sample width:	1.006 m	Sample weight:	44.4 kg/m2
Product	Single leaf AudioCore		
Identification:	Threshold=850		
	Head, hanging jamb & closing jamb=710		

Freq f Hz	Sound Reduction Index, dB	
	1/3 Oct	1/1 Oct
50+	19.8	22.0
63+	24.2	
80+	23.3	
100	25.7	28.2
125	28.8	
160	32.8	
200	32.6	34.2
250	34.6	
315	35.9	
400	36.3	36.8
500	37.3	
630	37.0	
800	36.4	35.7
1000	35.7	
1250	35.1	
1600	33.8	35.2
2000	35.6	
2500	36.7	
3150	36.9	38.9
4000	39.4	
5000	41.7	
6300+	45.2	45.6
8000+	46.4	
10000+	45.3	
Average 100-3150	34.5	

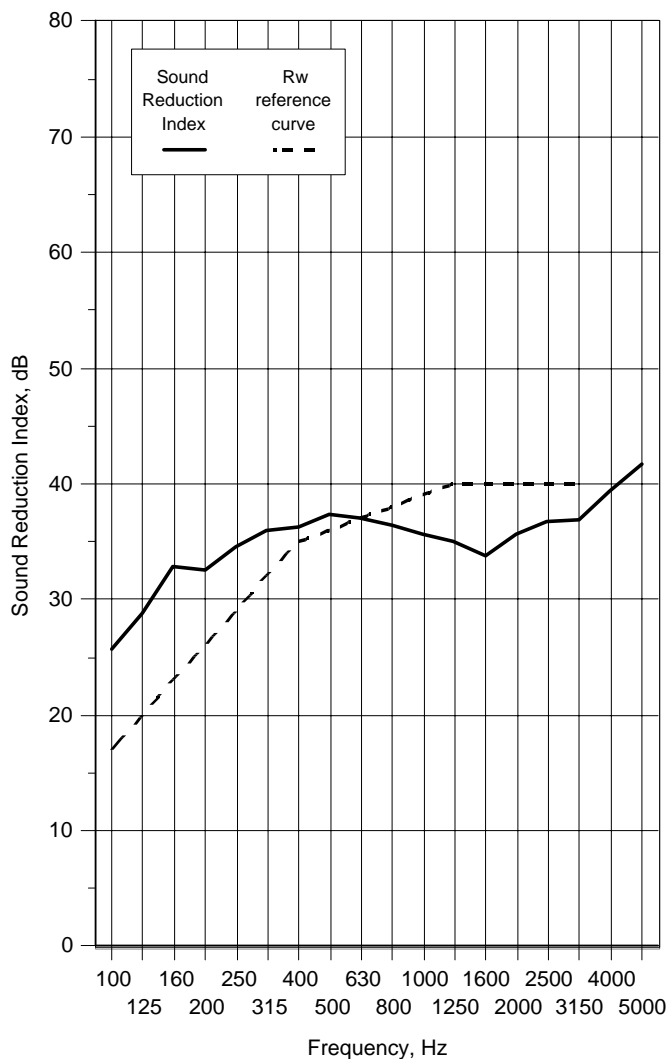

Rating according to BS EN ISO 717-1:1997

Rw(C;Ctr)= **36 (0;-1)** dB

Notes * designates measurement corrected for background
 # designates limit of measurement due to background
 + designates frequency beyond standard and not UKAS accredited

v1.6

Test Number :	96	Air temperature:	16.7 °C
Client:	Norsound Ltd	Air humidity:	69 %
Test Date:	09/06/2008	Receiving room volume	300 m ³
Sample height:	2.115 m	Source room volume:	115 m ³
Sample width:	1.006 m	Sample weight:	44.4 kg/m ²
Product	Single leaf AudioCore		
Identification:	Threshold=850		
	Head, hanging jamb & closing jamb=710		

Freq f Hz	Sound Reduction Index, dB	
	1/3 Oct	1/1 Oct
50+	20.2	21.9
63+	24.3	
80+	22.3	
100	25.7	28.1
125	28.6	
160	32.1	
200	32.3	34.0
250	34.3	
315	36.3	
400	36.2	37.0
500	37.6	
630	37.4	
800	37.3	36.8
1000	36.7	
1250	36.5	
1600	36.3	37.1
2000	37.7	
2500	37.5	
3150	37.5	39.7
4000	40.3	
5000	42.8	
6300+	45.2	45.5
8000+	45.9	
10000+	45.6	
Average 100-3150	35.0	

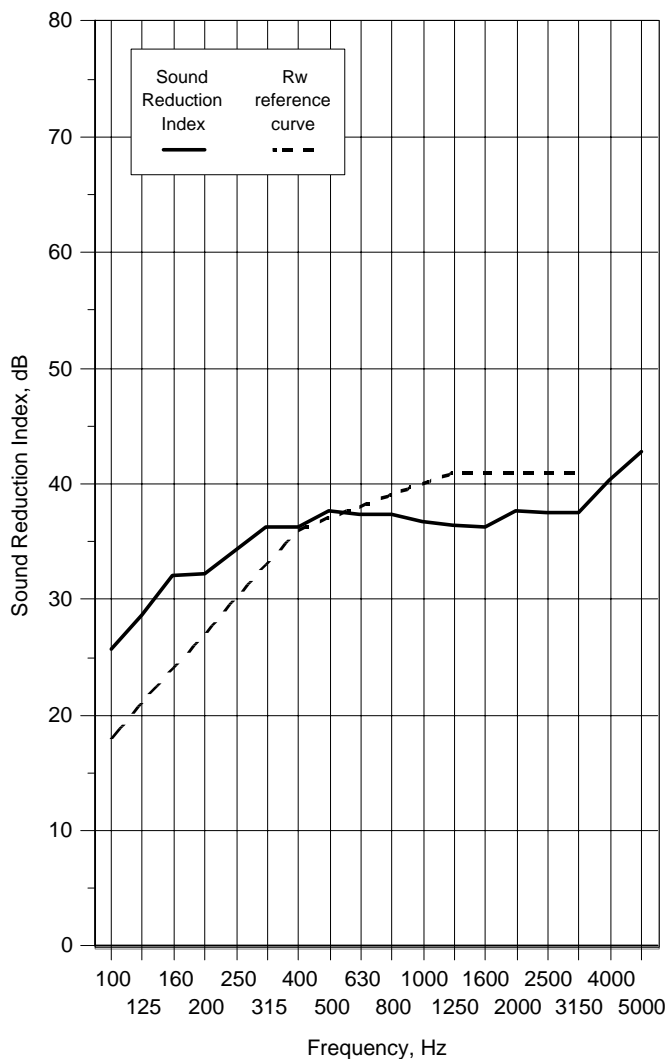

Rating according to BS EN ISO 717-1:1997

Rw(C;Ctr)= **37 (0;-1) dB**

Notes * designates measurement corrected for background

designates limit of measurement due to background

+ designates frequency beyond standard and not UKAS accredited

v1.6

Test Number :	97	Air temperature:	17 °C
Client:	Norsound Ltd	Air humidity:	70 %
Test Date:	09/06/2008	Receiving room volume	300 m3
Sample height:	2.115 m	Source room volume:	115 m3
Sample width:	1.006 m	Sample weight:	44.4 kg/m2
Product	Single leaf AudioCore		
Identification:	Threshold=850+650A Threshold		
	Head, hanging jamb & closing jamb=710		

Freq f Hz	Sound Reduction Index, dB	
	1/3 Oct	1/1 Oct
50+	21.4	22.9
63+	24.7	
80+	23.2	
100	24.9	27.6
125	28.5	
160	32.3	
200	32.5	34.2
250	34.4	
315	36.6	
400	36.8	37.8
500	38.4	
630	38.6	
800	38.8	39.6
1000	40.1	
1250	40.1	
1600	41.6	44.3
2000	45.9	
2500	47.7	
3150	48.7	49.5
4000	49.9	
5000	50.0	
6300+	52.4	53.3
8000+	53.3	
10000+	54.3 *	
Average 100-3150	37.9	

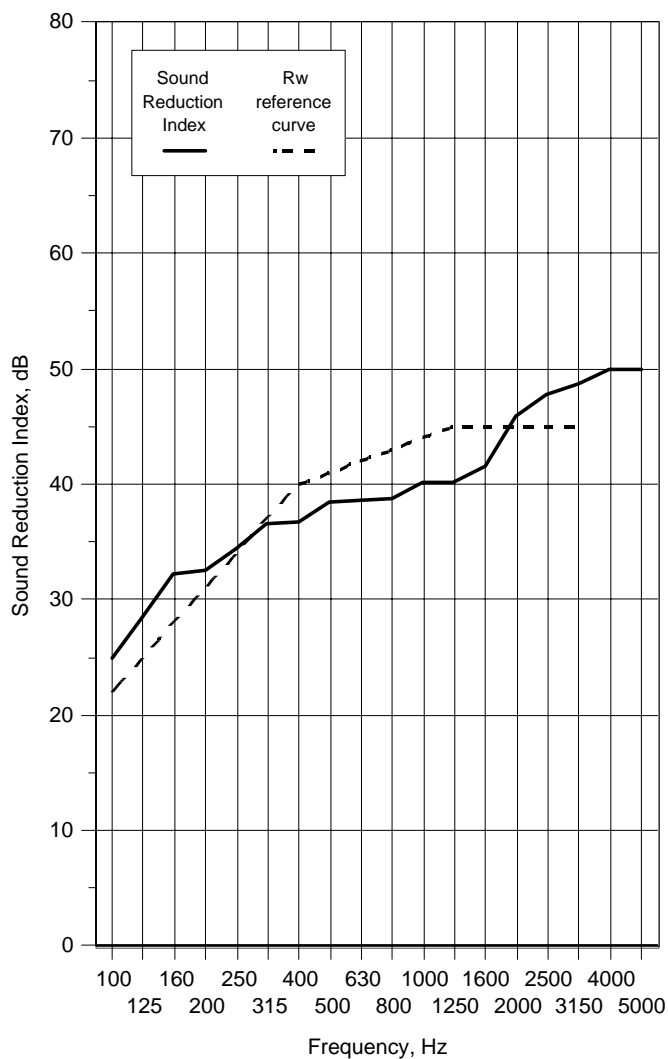

Rating according to BS EN ISO 717-1:1997

Rw(C;Ctr)= **41 (-1;-3) dB**

Notes * designates measurement corrected for background

designates limit of measurement due to background

+ designates frequency beyond standard and not UKAS accredited

v1.6

Test Number :	99	Air temperature:	17.4 °C
Client:	Norsound Ltd	Air humidity:	69 %
Test Date:	09/06/2008	Receiving room volume	300 m3
Sample height:	2.115 m	Source room volume:	115 m3
Sample width:	1.006 m	Sample weight:	44.4 kg/m2
Product	Single leaf AudioCore		
Identification:	Threshold=850+650A Threshold		
	Head, hanging jamb & closing jamb=710+755		

Freq f Hz	Sound Reduction Index, dB	
	1/3 Oct	1/1 Oct
50+	22.1	
63+	26.1	23.6
80+	23.5	
100	25.7	
125	28.9	28.2
160	32.7	
200	32.9	
250	34.9	34.5
315	36.6	
400	37.0	
500	38.7	38.1
630	38.8	
800	39.4	
1000	40.5	40.1
1250	40.4	
1600	42.0	
2000	47.3	45.2
2500	49.9	
3150	50.7	
4000	52.1	51.7
5000	52.7	
6300+	55.0	
8000+	55.8	* 56.0
10000+	57.8	*
Average 100-3150	38.5	

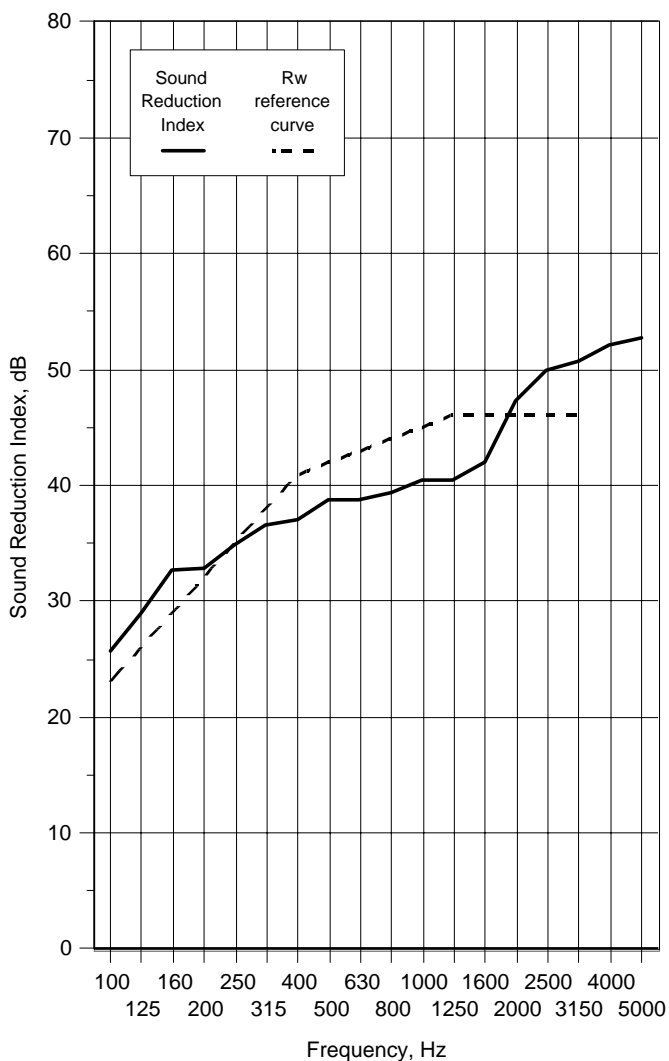

Rating according to BS EN ISO 717-1:1997

Rw(C;Ctr)= **42 (-1;-4)** dB

Notes * designates measurement corrected for background

designates limit of measurement due to background

+ designates frequency beyond standard and not UKAS accredited

v1.6

Test Number : 100 **Air temperature:** 17.6 °C
Client: Norsound Ltd **Air humidity:** 67 %
Test Date: 09/06/2008 **Receiving room volume** 300 m3
Sample height: 2.115 m **Source room volume:** 115 m3
Sample width: 1.006 m **Sample weight:** 44.4 kg/m2
Product Single leaf AudioCore
Identification: Threshold=850+650A Threshold
 Head, hanging jamb & closing jamb=710

Freq f Hz	Sound Reduction Index, dB	
	1/3 Oct	1/1 Oct
50+	21.6	23.1
63+	25.2	
80+	23.2	
100	25.2	27.6
125	28.2	
160	31.8	
200	32.6	34.3
250	34.5	
315	36.6	
400	37.0	37.9
500	38.4	
630	38.4	
800	38.7	39.5
1000	40.0	
1250	39.9	
1600	41.6	44.1
2000	45.7	
2500	47.3	
3150	48.4	49.1
4000	49.4	
5000	49.4	
6300+	52.3	53.3
8000+	53.2	
10000+	54.6 *	
Average 100-3150	37.8	

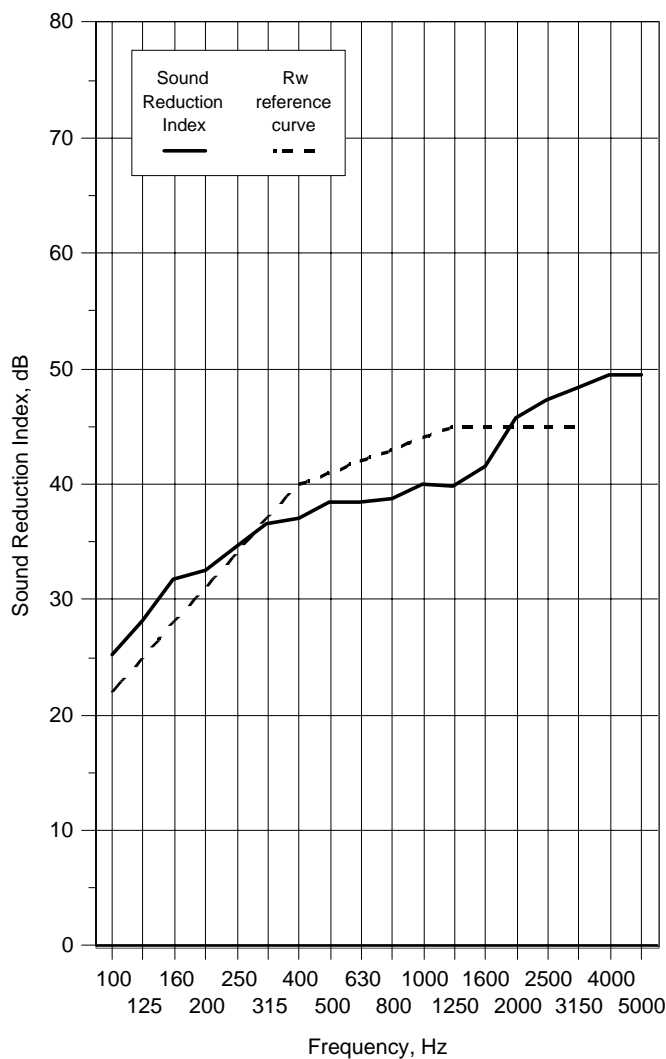

Rating according to BS EN ISO 717-1:1997

Rw(C;Ctr)= **41 (-1;-3) dB**

Notes * designates measurement corrected for background

designates limit of measurement due to background

+ designates frequency beyond standard and not UKAS accredited

v1.6

Test Number :	101	Air temperature:	17.6 °C
Client:	Norsound Ltd	Air humidity:	67 %
Test Date:	09/06/2008	Receiving room volume	300 m3
Sample height:	2.115 m	Source room volume:	115 m3
Sample width:	1.006 m	Sample weight:	44.4 kg/m2
Product	Single leaf AudioCore		
Identification:	Threshold=810		
	Head, hanging jamb & closing jamb=710		

Freq f Hz	Sound Reduction Index, dB	
	1/3 Oct	1/1 Oct
50+	21.3	
63+	24.6	22.8
80+	23.2	
100	25.1	
125	28.5	27.6
160	31.9	
200	32.5	
250	33.8	33.9
315	36.2	
400	36.4	
500	37.6	37.2
630	37.7	
800	37.7	
1000	36.9	37.1
1250	36.7	
1600	36.9	
2000	38.3	37.9
2500	38.6	
3150	39.9	
4000	43.3	42.2
5000	45.4	
6300+	47.9	
8000+	48.6	48.7
10000+	50.1	
Average 100-3150	35.3	

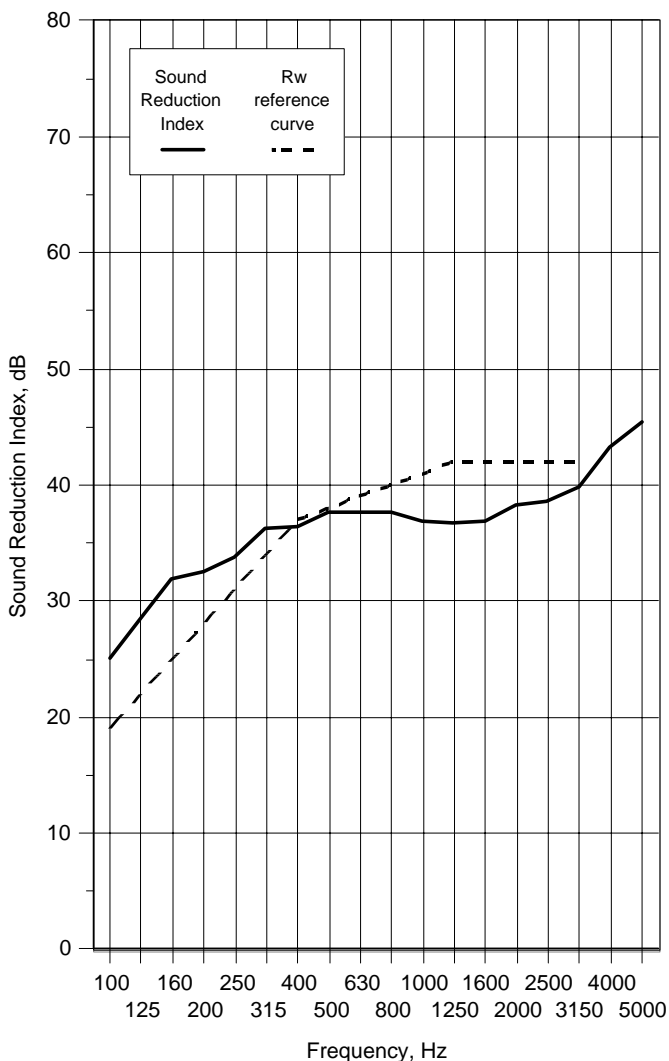

Rating according to BS EN ISO 717-1:1997

Rw(C;Ctr)= **38 (-1;-2) dB**

Notes * designates measurement corrected for background

designates limit of measurement due to background

+ designates frequency beyond standard and not UKAS accredited

v1.6

Test Number :	102	Air temperature:	17.6 °C
Client:	Norsound Ltd	Air humidity:	67 %
Test Date:	09/06/2008	Receiving room volume	300 m ³
Sample height:	2.115 m	Source room volume:	115 m ³
Sample width:	1.006 m	Sample weight:	44.4 kg/m ²
Product	Single leaf AudioCore		
Identification:	Threshold=810 + AcuPads		
	Head, hanging jamb & closing jamb=710		

Freq f Hz	Sound Reduction Index, dB	
	1/3 Oct	1/1 Oct
50+	21.3	22.8
63+	25.1	
80+	22.8	
100	25.2	27.7
125	28.6	
160	31.7	
200	32.9	34.3
250	34.5	
315	36.1	
400	36.4	37.2
500	37.8	
630	37.7	
800	38.2	38.1
1000	38.7	
1250	37.6	
1600	37.3	38.2
2000	38.2	
2500	39.0	
3150	41.7	43.9
4000	45.0	
5000	46.7	
6300+	48.9	50.4
8000+	50.6	
10000+	52.7	
Average 100-3150	35.7	

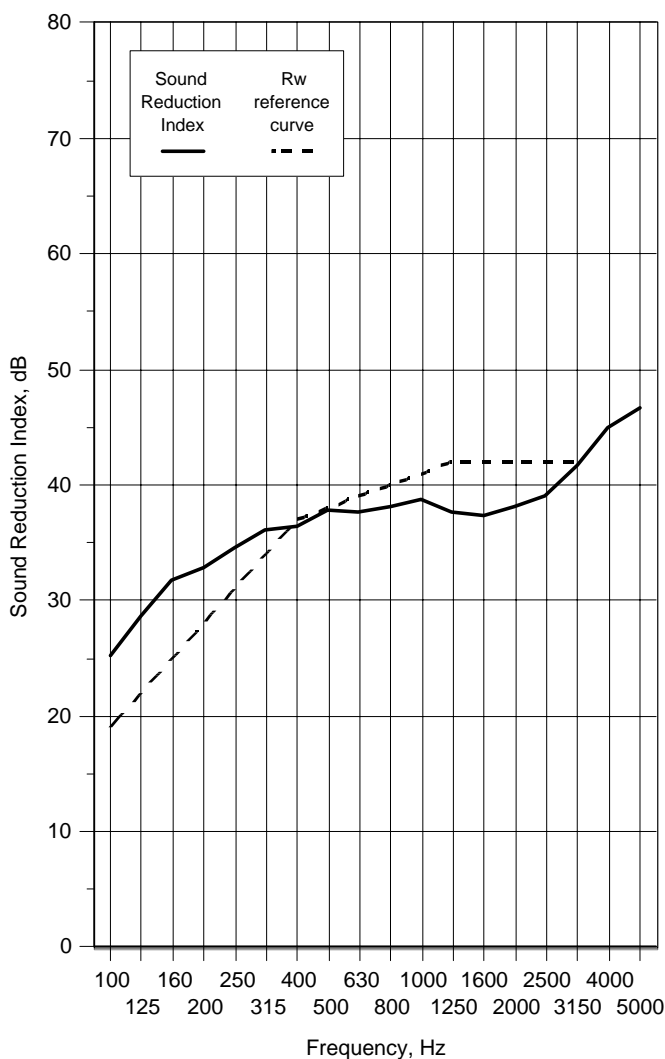

Rating according to BS EN ISO 717-1:1997

R_w(C;Ctr)= **38 (0;-2) dB**

Notes * designates measurement corrected for background

designates limit of measurement due to background

+ designates frequency beyond standard and not UKAS accredited

v1.6

Test Number :	103	Air temperature:	17.6 °C
Client:	Norsound Ltd	Air humidity:	67 %
Test Date:	09/06/2008	Receiving room volume	300 m3
Sample height:	2.115 m	Source room volume:	115 m3
Sample width:	1.006 m	Sample weight:	44.4 kg/m2
Product	Single leaf AudioCore		
Identification:	Fully caulked		

Freq f Hz	Sound Reduction Index, dB	
	1/3 Oct	1/1 Oct
50+	19.2	
63+	25.7	22.0
80+	23.6	
100	25.0	
125	29.0	27.8
160	32.8	
200	33.0	
250	35.1	34.7
315	37.0	
400	37.4	
500	39.0	38.4
630	39.0	
800	39.6	
1000	40.9	40.8
1250	42.4	
1600	45.6	
2000	49.9	48.2
2500	51.5	
3150	52.0	
4000	53.4	53.4
5000	55.4	
6300+	56.8	
8000+	58.6	* 58.4
10000+	60.5	*
Average 100-3150	39.3	

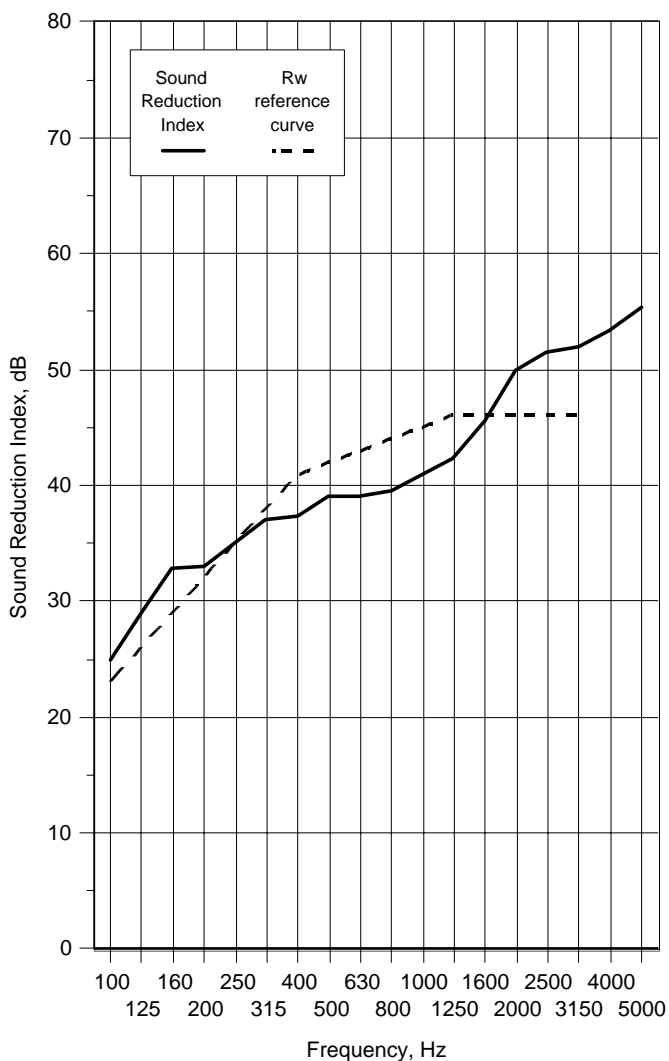

Rating according to BS EN ISO 717-1:1997

Rw(C;Ctr)= **42 (-1;-4)** dB

Notes * designates measurement corrected for background

designates limit of measurement due to background

+ designates frequency beyond standard and not UKAS accredited

v1.6

Test Number :	104	Air temperature:	18.9 °C
Client:	Norsound Ltd	Air humidity:	69 %
Test Date:	09/06/2008	Receiving room volume	300 m3
Sample height:	2.115 m	Source room volume:	115 m3
Sample width:	1.006 m	Sample weight:	23.4 kg/m2
Product	Single leaf Flamebreak 660		
Identification:	Fully caulked		

Freq f Hz	Sound Reduction Index, dB	
	1/3 Oct	1/1 Oct
50+	22.0	19.6
63+	19.6	
80+	18.1	
100	17.9	20.2
125	20.5	
160	24.6	26.2
200	24.6	
250	26.6	
315	28.0	28.2
400	27.5	
500	28.7	
630	28.5	29.6
800	28.2	
1000	29.4	
1250	31.9	35.0
1600	33.5	
2000	35.0	
2500	37.1	41.0
3150	39.4	
4000	41.3	
5000	42.9	42.9
6300+	43.9	
8000+	43.1	
10000+	42.0	
Average 100-3150	28.8	

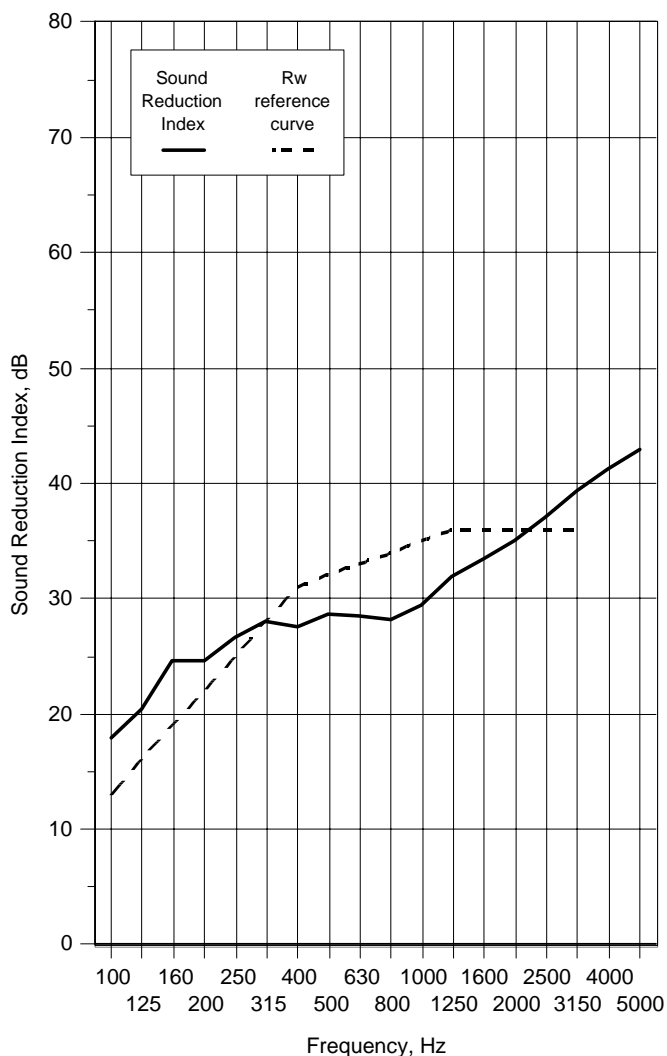

Rating according to BS EN ISO 717-1:1997

Rw(C;Ctr)= **32 (-1;-3) dB**

Notes * designates measurement corrected for background

designates limit of measurement due to background

+ designates frequency beyond standard and not UKAS accredited

v1.6

Test Number : 105 **Air temperature:** 19.8 °C
Client: Norsound Ltd **Air humidity:** 72 %
Test Date: 09/06/2008 **Receiving room volume** 300 m³
Sample height: 2.115 m **Source room volume:** 115 m³
Sample width: 1.006 m **Sample weight:** 23.4 kg/m²
Product Single leaf Flamebreak 660.
Identification: Threshold=2x855 used with 620 threshold
 Head, hanging jamb & closing jamb=2x720

Freq f Hz	Sound Reduction Index, dB	
	1/3 Oct	1/1 Oct
50+	15.0	16.0
63+	17.2	
80+	16.2	
100	19.0	21.5
125	22.2	
160	26.0	
200	25.3	26.6
250	27.1	
315	27.9	
400	26.5	27.0
500	27.5	
630	27.1	
800	27.0	28.4
1000	28.2	
1250	30.7	
1600	32.0	33.4
2000	33.3	
2500	35.6	
3150	38.3	39.1
4000	39.7	
5000	39.5	
6300+	40.6	40.4
8000+	40.8	
10000+	39.9	
Average 100-3150	28.4	

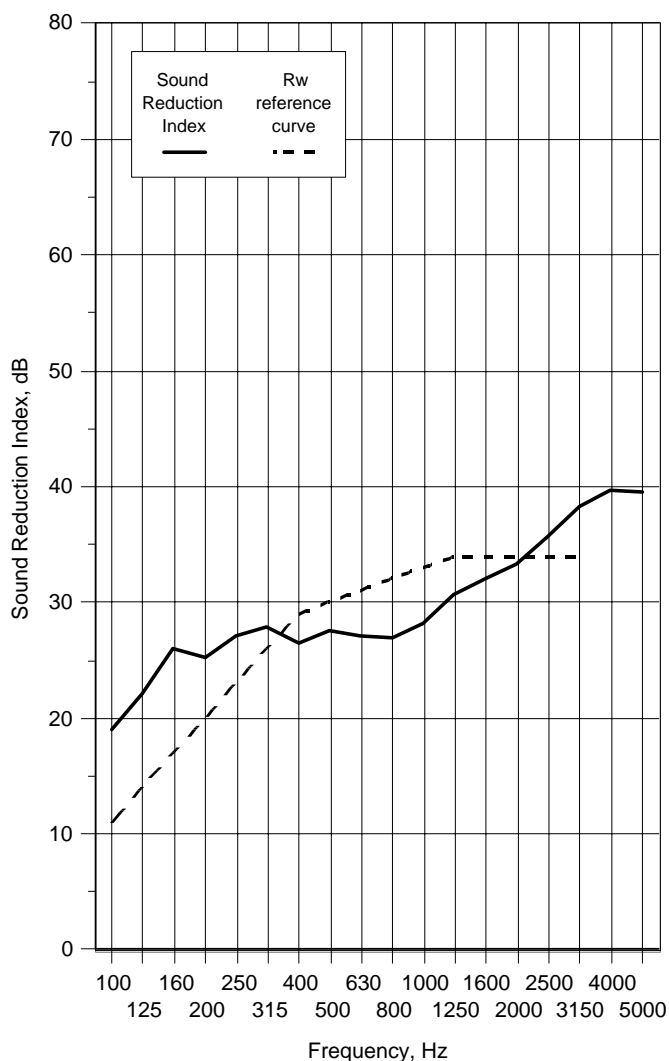

Rating according to BS EN ISO 717-1:1997

Rw(C;Ctr)= **30 (0;-2) dB**

Notes * designates measurement corrected for background

designates limit of measurement due to background

+ designates frequency beyond standard and not UKAS accredited

v1.6

Test Number :	107	Air temperature:	18.9 °C
Client:	Norsound Ltd	Air humidity:	68 %
Test Date:	10/06/2008	Receiving room volume	300 m3
Sample height:	2.115 m	Source room volume:	31 m3
Sample width:	1.006 m	Sample weight:	31.4 kg/m2
Product	Single leaf double action Strebord 54		
Identification:	Fully caulked		

Freq f Hz	Sound Reduction Index, dB	
	1/3 Oct	1/1 Oct
50+	18.7	18.0
63+	16.7	
80+	18.9	
100	24.6	26.1
125	25.3	
160	30.1	
200	28.6	30.2
250	30.2	
315	33.0	
400	33.4	34.2
500	34.6	
630	34.7	
800	31.7	30.2
1000	29.5	
1250	29.7	
1600	31.0	32.4
2000	32.2	
2500	34.9	
3150	35.2	36.7
4000	36.6	
5000	39.1	
6300+	42.3	44.3
8000+	44.8	
10000+	47.4	
Average 100-3150	31.2	

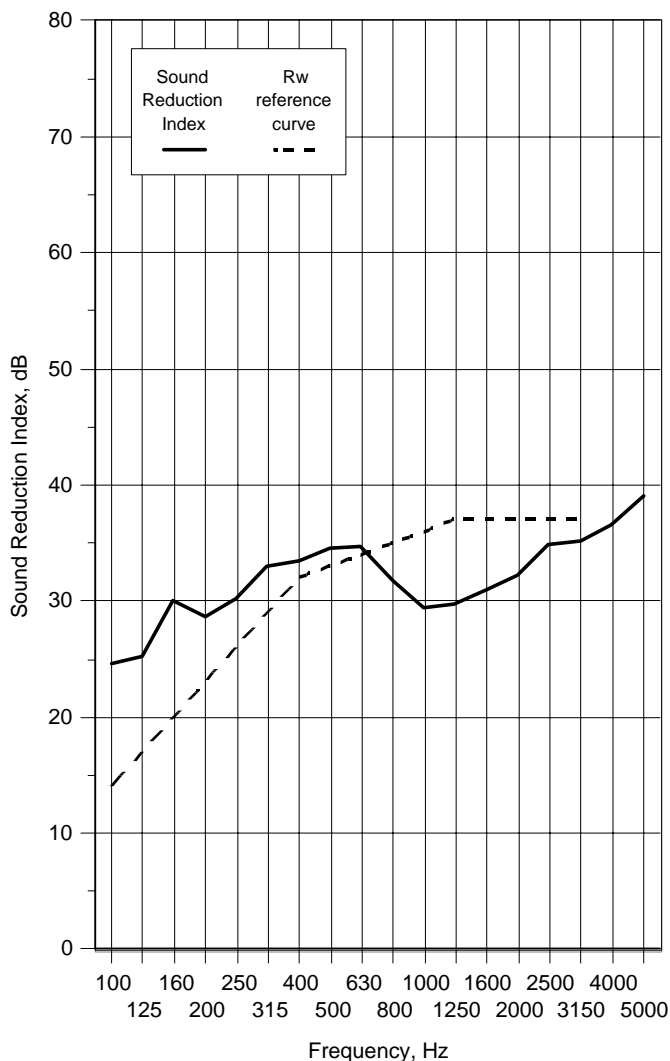

Rating according to BS EN ISO 717-1:1997

Rw(C;Ctr)= **33 (-1;-2)** dB

Notes * designates measurement corrected for background
 # designates limit of measurement due to background
 + designates frequency beyond standard and not UKAS accredited

v1.6

Test Number :	108	Air temperature:	17.2 °C
Client:	Norsound Ltd	Air humidity:	71 %
Test Date:	09/06/2008	Receiving room volume	300 m3
Sample height:	2.115 m	Source room volume:	115 m3
Sample width:	1.006 m	Sample weight:	44.4 kg/m2
Product	Single leaf AudioCore		
Identification:	Threshold=850+650A threshold		
	Head, hanging jamb & closing jamb=2x710		

Freq f Hz	Sound Reduction Index, dB	
	1/3 Oct	1/1 Oct
50+	18.4	21.2
63+	24.8	
80+	23.1	
100	25.4	28.2
125	29.3	
160	33.2	
200	32.4	34.2
250	34.6	
315	36.6	
400	37.3	38.3
500	38.9	
630	38.9	
800	39.2	40.6
1000	40.9	
1250	42.3	
1600	44.2	45.5
2000	45.2	
2500	47.7	
3150	49.4	50.9
4000	51.1	
5000	52.8	
6300+	52.7	54.1
8000+	54.1	
10000+	56.1 *	
Average 100-3150	38.5	

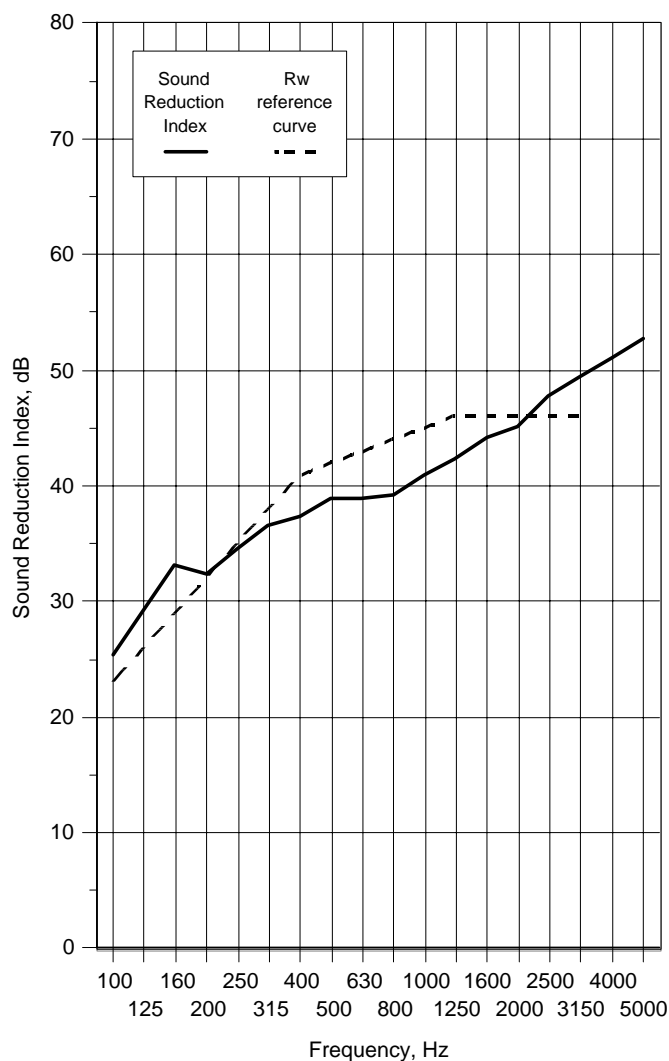

Rating according to BS EN ISO 717-1:1997

Rw(C;Ctr)= **42 (-1;-4)** dB

Notes * designates measurement corrected for background

designates limit of measurement due to background

+ designates frequency beyond standard and not UKAS accredited

v1.6

Test Number :	109	Air temperature:	19 °C
Client:	Norsound Ltd	Air humidity:	68 %
Test Date:	10/06/2008	Receiving room volume	300 m ³
Sample height:	2.115 m	Source room volume:	115 m ³
Sample width:	1.006 m	Sample weight:	31.4 kg/m ²
Product	Single leaf double action Strebord 54		
Identification:	Threshold=2x855 with 620 threshold		
	Head, hanging jamb & closing jamb=2x720		

Freq f Hz	Sound Reduction Index, dB	
	1/3 Oct	1/1 Oct
50+	21.9	22.2
63+	22.9	
80+	21.8	
100	23.0	24.7
125	24.2	
160	28.4	
200	29.4	30.8
250	30.7	
315	32.9	
400	33.8	34.6
500	35.2	
630	34.8	
800	31.4	29.2
1000	28.3	
1250	28.4	
1600	30.3	31.9
2000	31.9	
2500	34.6	
3150	35.2	36.5
4000	36.3	
5000	38.5	
6300+	41.2	43.0
8000+	43.4	
10000+	45.5	
Average 100-3150	30.8	

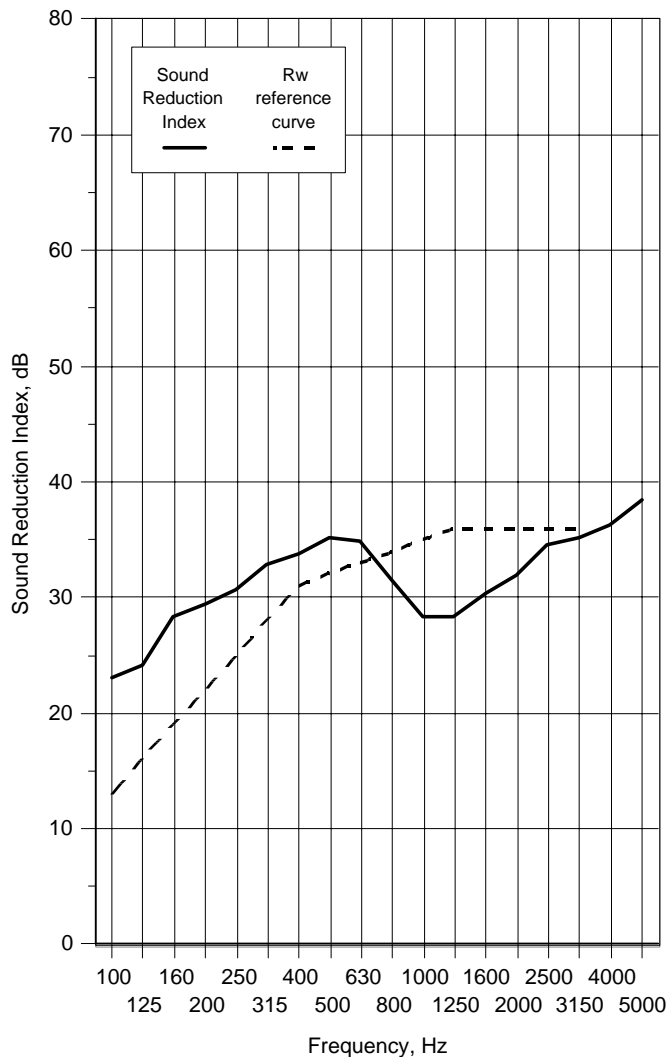

Rating according to BS EN ISO 717-1:1997

Rw(C;Ctr)= **32 (-1;-2)** dB

Notes * designates measurement corrected for background

designates limit of measurement due to background

+ designates frequency beyond standard and not UKAS accredited

v1.6

Test Number :	110	Air temperature:	19 °C
Client:	Norsound Ltd	Air humidity:	68 %
Test Date:	10/06/2008	Receiving room volume	300 m3
Sample height:	2.115 m	Source room volume:	115 m3
Sample width:	1.006 m	Sample weight:	27.4 kg/m2
Product	Single leaf double action Strebord 44		
Identification:	Fully caulked		

Freq f Hz	Sound Reduction Index, dB	
	1/3 Oct	1/1 Oct
50+	18.6	19.5
63+	20.0	
80+	19.8	
100	23.6	24.5
125	23.2	
160	28.2	
200	28.4	29.9
250	29.9	
315	32.1	
400	33.0	34.1
500	34.7	
630	34.9	
800	33.1	30.1
1000	29.5	
1250	28.7	
1600	30.3	32.3
2000	32.6	
2500	35.3	
3150	37.7	37.9
4000	39.4	
5000	36.8	
6300+	39.9	42.0
8000+	42.4	
10000+	45.3	
Average 100-3150	31.0	

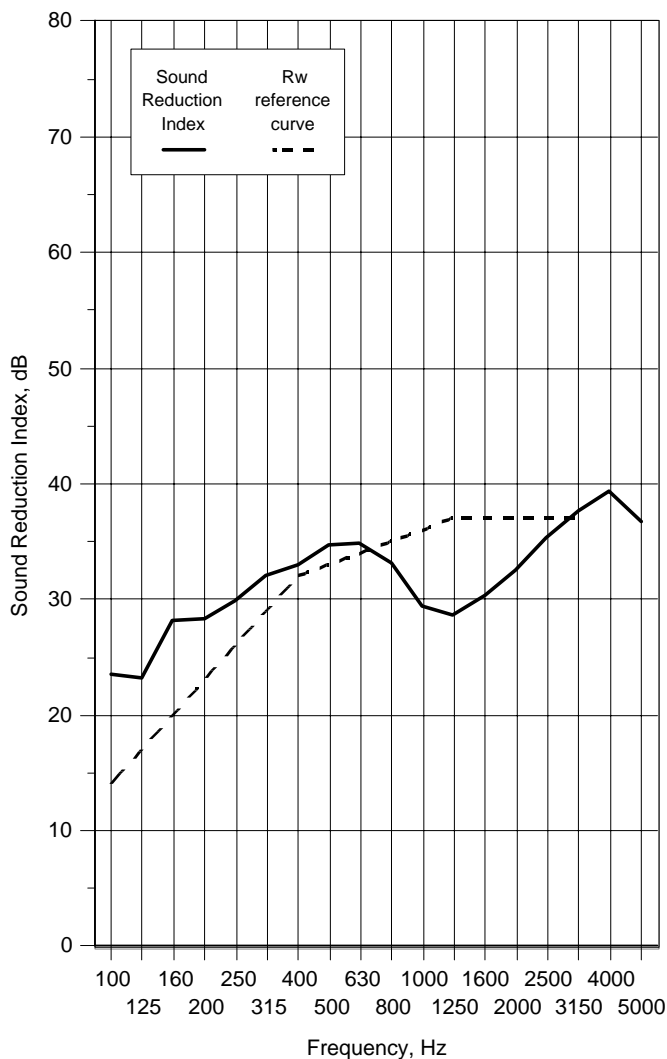

Rating according to BS EN ISO 717-1:1997

Rw(C;Ctr)= **33 (-1;-2)** dB

Notes * designates measurement corrected for background
 # designates limit of measurement due to background
 + designates frequency beyond standard and not UKAS accredited

v1.6

Test Number : 111 **Air temperature:** 19.1 °C
Client: Norsound Ltd **Air humidity:** 68 %
Test Date: 10/06/2008 **Receiving room volume** 300 m3
Sample height: 2.115 m **Source room volume:** 115 m3
Sample width: 1.006 m **Sample weight:** 27.4 kg/m2
Product Single leaf double action Strebord 44
Identification: Threshold=2 x 855 used with 620 threshold
 Head, hanging jamb & closing jamb=2x720

Freq f Hz	Sound Reduction Index, dB	
	1/3 Oct	1/1 Oct
50+	24.0	22.0
63+	23.0	
80+	20.1	
100	22.0	24.2
125	24.3	
160	28.6	
200	29.0	30.3
250	30.1	
315	32.3	
400	33.2	34.1
500	34.5	
630	34.6	
800	32.4	28.8
1000	28.2	
1250	27.3	
1600	29.0	31.2
2000	31.7	
2500	34.4	
3150	37.0	37.3
4000	38.5	
5000	36.6	
6300+	39.4	41.4
8000+	41.8	
10000+	44.0	
Average 100-3150	30.5	

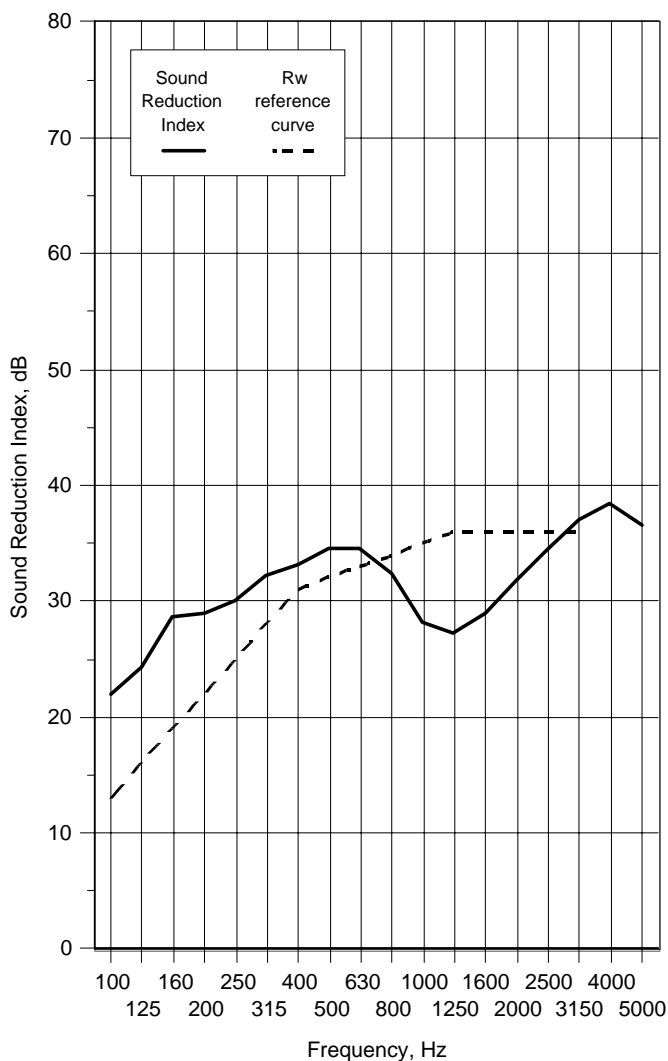

Rating according to BS EN ISO 717-1:1997

Rw(C;Ctr)= **32 (-1;-2)** dB

Notes * designates measurement corrected for background

designates limit of measurement due to background

+ designates frequency beyond standard and not UKAS accredited

v1.6

Test Number :	112	Air temperature:	19.1 °C
Client:	Norsound Ltd	Air humidity:	68 %
Test Date:	10/06/2008	Receiving room volume	300 m ³
Sample height:	2.115 m	Source room volume:	115 m ³
Sample width:	1.006 m	Sample weight:	17.3 kg/m ²
Product	Single leaf Flamebreak 430		
Identification:	Fully caulked		

Freq f Hz	Sound Reduction Index, dB	
	1/3 Oct	1/1 Oct
50+	24.2	14.8
63+	19.0	
80+	10.8	
100	14.8	17.2
125	17.9	
160	21.2	23.9
200	22.2	
250	24.3	
315	26.1	
400	26.2	26.7
500	27.4	
630	26.7	26.4
800	25.3	
1000	26.2	
1250	28.3	
1600	29.8	31.7
2000	32.0	
2500	34.4	
3150	36.2	38.2
4000	38.6	
5000	40.9	44.1
6300+	43.4	
8000+	44.7	
10000+	44.2	
Average 100-3150	26.2	

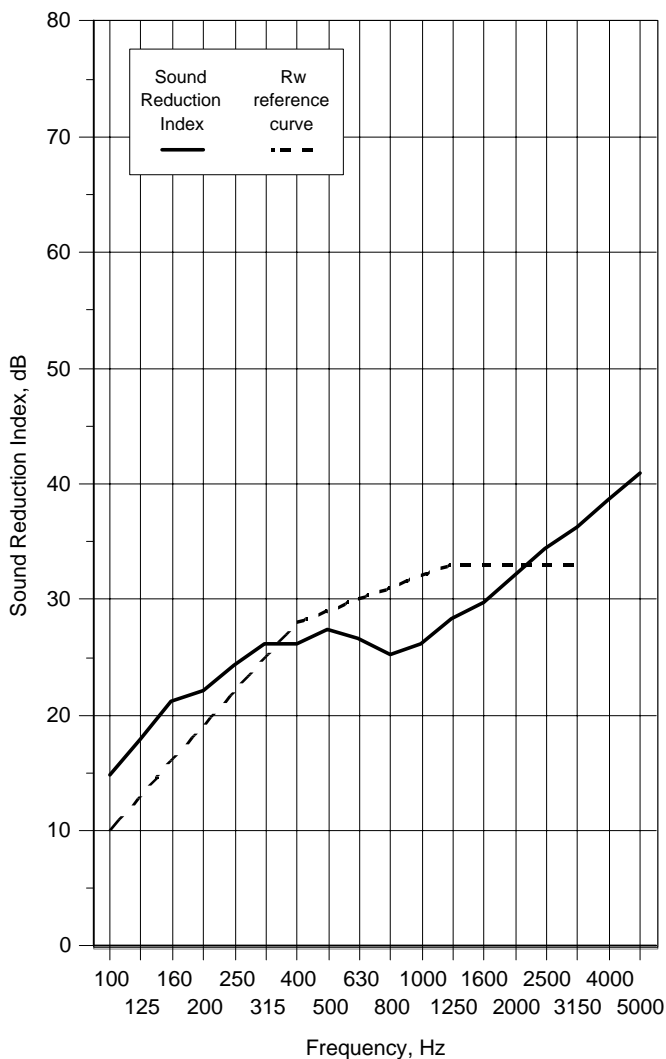

Rating according to BS EN ISO 717-1:1997

Rw(C;Ctr)= **29 (-1;-3)** dB

Notes * designates measurement corrected for background

designates limit of measurement due to background

+ designates frequency beyond standard and not UKAS accredited

v1.6

Test Number :	113	Air temperature:	19.1 °C
Client:	Norsound Ltd	Air humidity:	68 %
Test Date:	10/06/2008	Receiving room volume	300 m3
Sample height:	2.115 m	Source room volume:	115 m3
Sample width:	1.006 m	Sample weight:	17.3 kg/m2
Product	Single leaf Flamebreak 430		
Identification:	Threshold=2x855 used with 620 threshold Head, hanging jamb & closing jamb=2x720		

Freq f Hz	Sound Reduction Index, dB	
	1/3 Oct	1/1 Oct
50+	14.6	14.5
63+	14.9	
80+	13.9	
100	17.5	19.2
125	18.5	
160	23.6	24.7
200	23.2	
250	25.2	
315	26.3	25.8
400	25.8	
500	26.1	
630	25.6	25.4
800	24.1	
1000	25.1	
1250	27.5	30.7
1600	28.9	
2000	31.0	
2500	33.4	36.9
3150	35.2	
4000	37.1	
5000	39.3	41.6
6300+	40.9	
8000+	41.8	
10000+	42.1	
Average 100-3150	26.1	

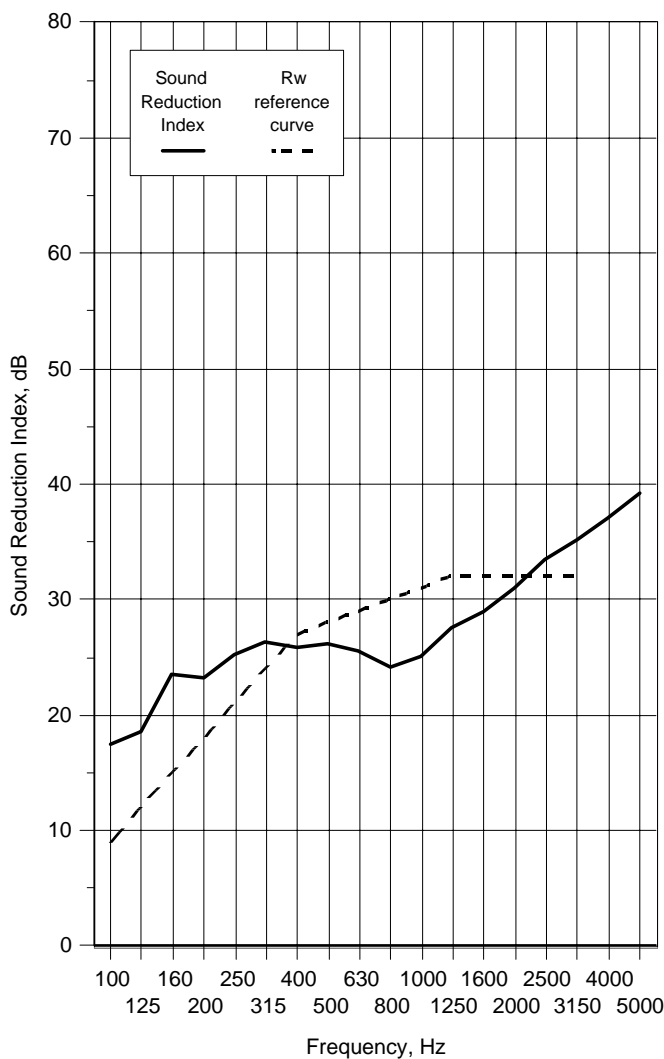

Rating according to BS EN ISO 717-1:1997

Rw(C;Ctr)= **28 (-1;-2) dB**

Notes * designates measurement corrected for background

designates limit of measurement due to background

+ designates frequency beyond standard and not UKAS accredited

v1.6

Test Number :	115	Air temperature:	18.5 °C
Client:	Norsound Ltd	Air humidity:	73 %
Test Date:	07/07/2008	Receiving room volume	300 m ³
Sample height:	2.119 m	Source room volume:	115 m ³
Sample width:	1.004 m	Sample weight:	18.3 kg/m ²
Product	Single leaf Flamebreak 430. Glazing=reference panel (as door leaf)		
Identification:	Fully caulked		

Freq f Hz	Sound Reduction Index, dB	
	1/3 Oct	1/1 Oct
50+	19.3	19.1
63+	18.3	
80+	19.9	
100	20.0	23.4
125	26.4	
160	28.2	
200	25.0	25.1
250	23.5	
315	27.9	
400	29.6	29.3
500	29.6	
630	28.9	
800	28.4	29.3
1000	29.0	
1250	30.7	
1600	32.3	33.9
2000	34.2	
2500	35.9	
3150	38.1	39.9
4000	39.9	
5000	42.8	
6300+	45.0	45.6
8000+	46.6	
10000+	45.4	
Average 100-3150	29.2	

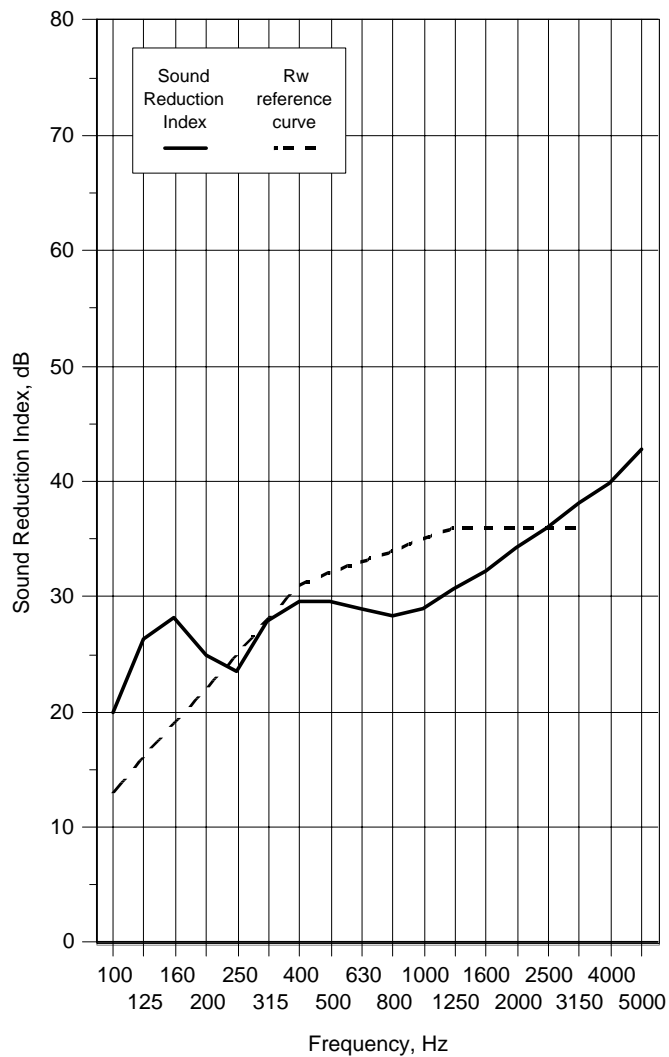

Rating according to BS EN ISO 717-1:1997

Rw(C;Ctr)= **32 (-1;-3) dB**

Notes * designates measurement corrected for background

designates limit of measurement due to background

+ designates frequency beyond standard and not UKAS accredited

v1.6

Test Number : 116 **Air temperature:** 18.5 °C
Client: Norsound Ltd **Air humidity:** 73 %
Test Date: 07/07/2008 **Receiving room volume** 300 m3
Sample height: 2.119 m **Source room volume:** 115 m3
Sample width: 1.004 m **Sample weight:** 18.3 kg/m2
Product Single leaf Flamebreak 430. Glazing=reference panel (as door leaf)
Identification: Threshold=810
 Head, hanging jamb & closing jamb=710

Freq f Hz	Sound Reduction Index, dB	
	1/3 Oct	1/1 Oct
50+	18.4	17.3
63+	18.5	
80+	15.7	
100	19.4	22.3
125	23.8	
160	26.9	
200	23.5	24.9
250	24.2	
315	28.2	
400	29.0	28.7
500	28.5	
630	28.5	
800	28.2	28.8
1000	28.7	
1250	29.7	
1600	31.3	32.8
2000	33.1	
2500	34.9	
3150	35.9	36.3
4000	35.1	
5000	38.5	
6300+	41.1	42.2
8000+	42.8	
10000+	42.9	
Average 100-3150	28.4	

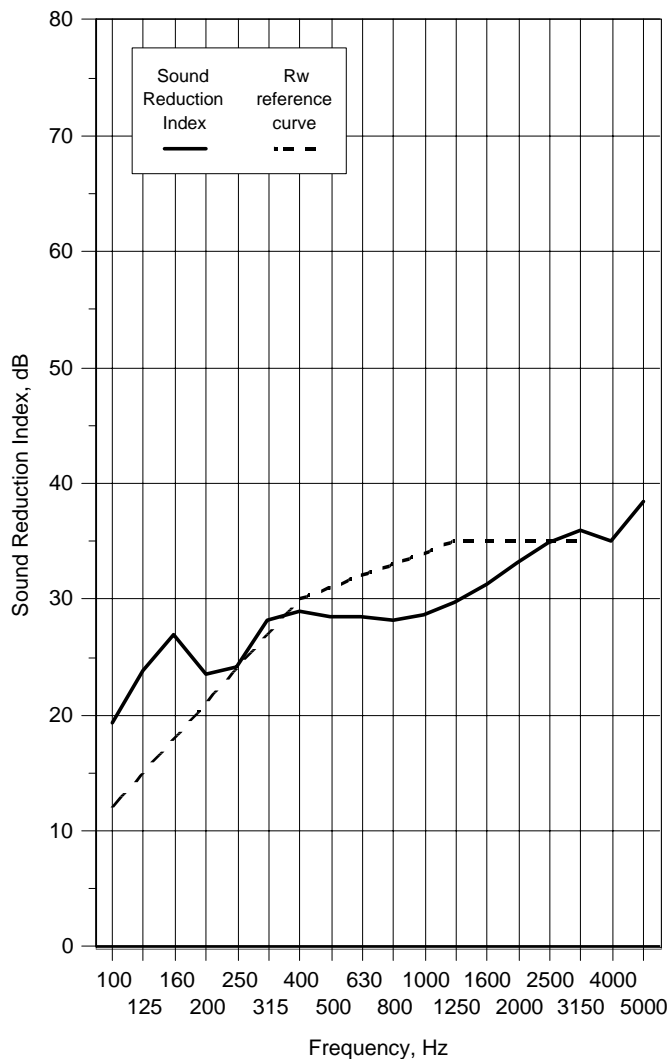

Rating according to BS EN ISO 717-1:1997

Rw(C;Ctr)= **31 (-1;-3) dB**

Notes * designates measurement corrected for background

designates limit of measurement due to background

+ designates frequency beyond standard and not UKAS accredited

v1.6

Test Number :	117	Air temperature:	18.5 °C
Client:	Norsound Ltd	Air humidity:	73 %
Test Date:	07/07/2008	Receiving room volume	300 m ³
Sample height:	2.119 m	Source room volume:	115 m ³
Sample width:	1.004 m	Sample weight:	18.8 kg/m ²
Product	Single leaf Flamebreak 430		
Identification:	Glazing=6mm Pyroshield (25% of door leaf area)		
	Threshold=810		
	Head, hanging jamb & closing jamb=710		

Freq f Hz	Sound Reduction Index, dB	
	1/3 Oct	1/1 Oct
50+	20.4	18.6
63+	18.7	
80+	17.2	
100	20.3	23.2
125	25.1	
160	26.8	
200	24.1	25.5
250	24.9	
315	28.8	
400	30.0	30.3
500	30.3	
630	30.7	
800	30.3	30.8
1000	30.7	
1250	31.5	
1600	31.2	32.4
2000	32.3	
2500	34.2	
3150	35.6	36.2
4000	35.1	
5000	38.4	
6300+	40.7	41.8
8000+	42.2	
10000+	42.8	
Average 100-3150	29.2	

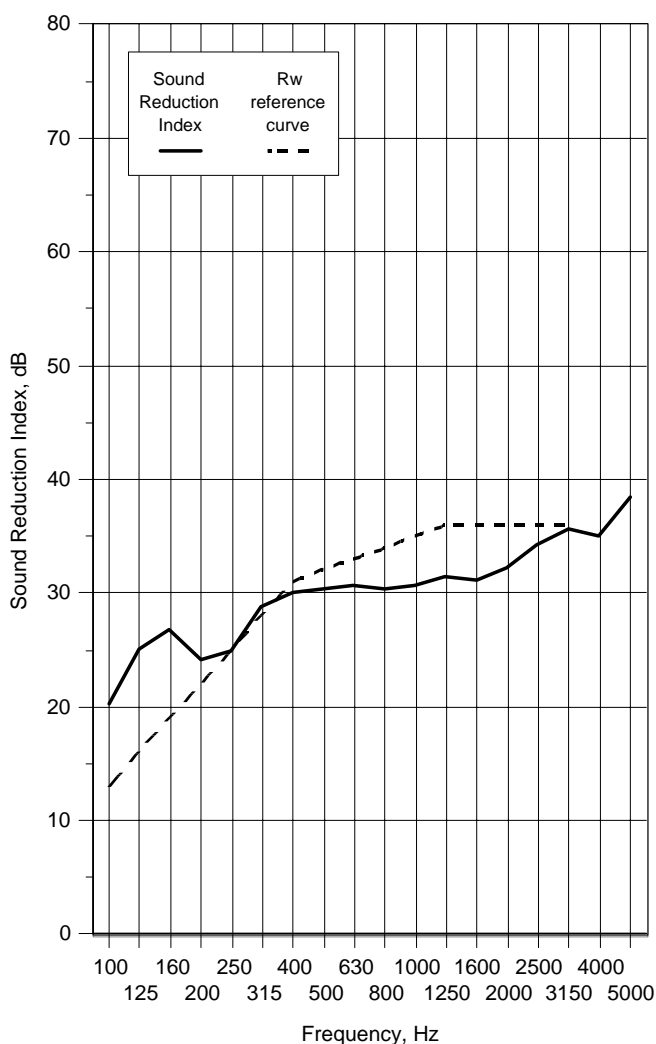

Rating according to BS EN ISO 717-1:1997

Rw(C;Ctr)= **32 (-1;-2)** dB

Notes * designates measurement corrected for background

designates limit of measurement due to background

+ designates frequency beyond standard and not UKAS accredited

v1.6

Test Number :	118	Air temperature:	18.5 °C
Client:	Norsound Ltd	Air humidity:	73 %
Test Date:	07/07/2008	Receiving room volume	300 m ³
Sample height:	2.119 m	Source room volume:	115 m ³
Sample width:	1.004 m	Sample weight:	20.7 kg/m ²
Product	Single leaf Flamebreak 430		
Identification:	Glazing=10mm Pyrodur (25% of door leaf area)		
	Threshold=810		
	Head, hanging jamb & closing jamb=710		

Freq f Hz	Sound Reduction Index, dB	
	1/3 Oct	1/1 Oct
50+	21.4	20.4
63+	21.1	
80+	19.0	
100	20.8	24.0
125	26.8	
160	27.7	
200	23.5	25.4
250	25.4	
315	29.0	
400	30.3	30.6
500	30.9	
630	30.6	
800	30.5	30.7
1000	30.5	
1250	31.2	
1600	31.7	33.1
2000	33.2	
2500	35.2	
3150	36.8	37.0
4000	35.9	
5000	38.9	
6300+	40.9	42.1
8000+	42.5	
10000+	43.2	
Average 100-3150	29.6	

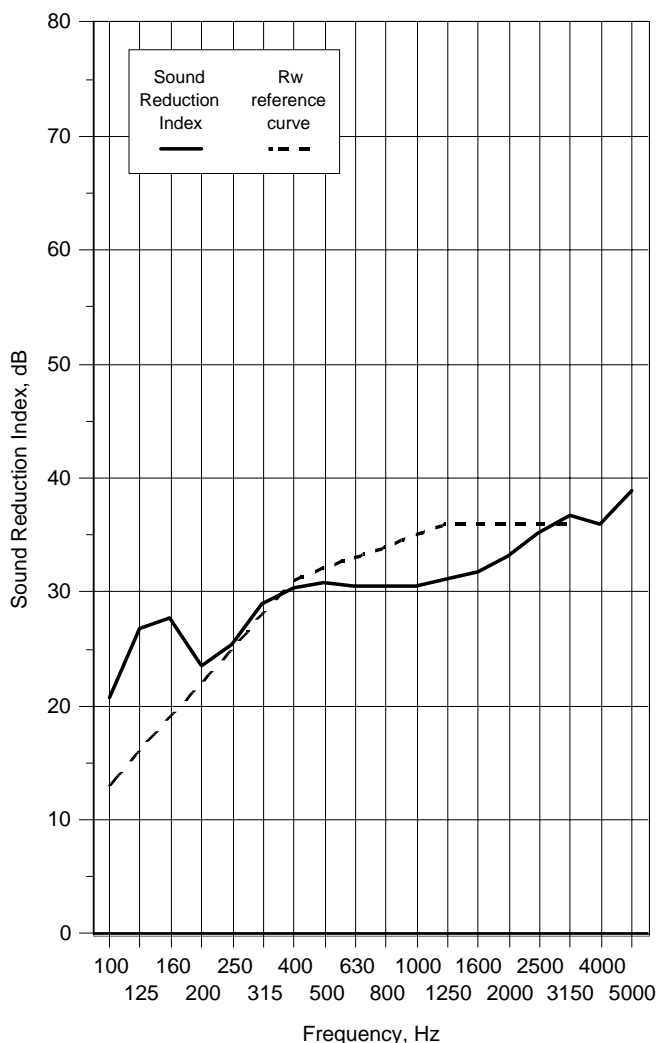

Rating according to BS EN ISO 717-1:1997

Rw(C;Ctr)= **32 (-1;-2)** dB

Notes * designates measurement corrected for background

designates limit of measurement due to background

+ designates frequency beyond standard and not UKAS accredited

v1.6

Test Number :	119	Air temperature:	18.6 °C
Client:	Norsound Ltd	Air humidity:	71 %
Test Date:	07/07/2008	Receiving room volume	300 m ³
Sample height:	2.119 m	Source room volume:	115 m ³
Sample width:	1.004 m	Sample weight:	23.5 kg/m ²
Product	Single leaf Flamebreak 430		
Identification:	Glazing=15mm Pyrostop (25% of door leaf area)		
	Threshold=810		
	Head, hanging jamb & closing jamb=710		

Freq f Hz	Sound Reduction Index, dB	
	1/3 Oct	1/1 Oct
50+	22.1	21.1
63+	21.6	
80+	19.8	
100	22.4	25.0
125	26.9	
160	28.1	
200	23.1	25.1
250	24.8	
315	29.2	
400	30.6	30.7
500	31.0	
630	30.6	
800	30.0	30.4
1000	30.3	
1250	31.1	
1600	32.5	33.9
2000	34.0	
2500	35.7	
3150	37.3	37.8
4000	36.7	
5000	40.0	
6300+	41.9	42.9
8000+	43.3	
10000+	43.7	
Average 100-3150	29.9	

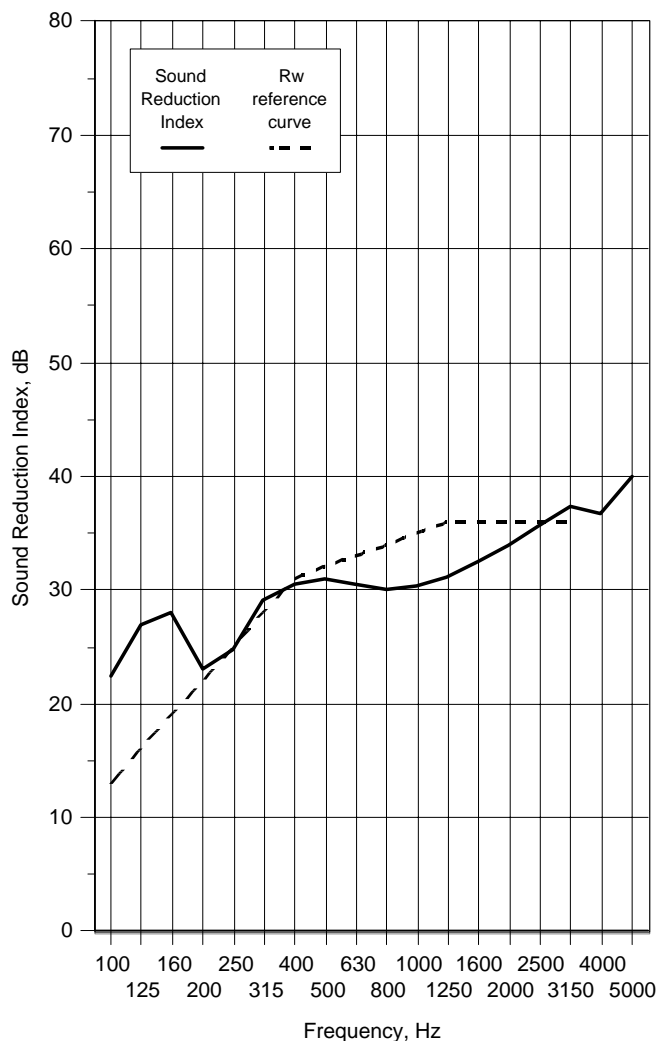

Rating according to BS EN ISO 717-1:1997

Rw(C;Ctr)= **32 (0;-2)** dB

Notes * designates measurement corrected for background

designates limit of measurement due to background

+ designates frequency beyond standard and not UKAS accredited

v1.6

Test Number :	120	Air temperature:	18.6 °C
Client:	Norsound Ltd	Air humidity:	71 %
Test Date:	07/07/2008	Receiving room volume	300 m ³
Sample height:	2.119 m	Source room volume:	115 m ³
Sample width:	1.004 m	Sample weight:	25.4 kg/m ²
Product	Single leaf Flamebreak 430		
Identification:	Glazing=16.8mm Optilam-Phon (25% of door leaf area)		
	Threshold=810		
	Head, hanging jamb & closing jamb=710		

Freq f Hz	Sound Reduction Index, dB	
	1/3 Oct	1/1 Oct
50+	23.3	21.6
63+	22.7	
80+	19.8	
100	23.3	25.5
125	27.3	
160	27.4	
200	23.1	
250	25.3	25.1
315	28.7	
400	30.2	
500	31.0	30.7
630	30.8	
800	30.4	
1000	30.8	31.0
1250	31.7	
1600	32.4	
2000	33.9	
2500	35.6	33.8
3150	37.3	
4000	36.9	
5000	40.1	37.9
6300+	42.0	
8000+	43.2	
10000+	43.3	42.8
Average 100-3150	30.0	

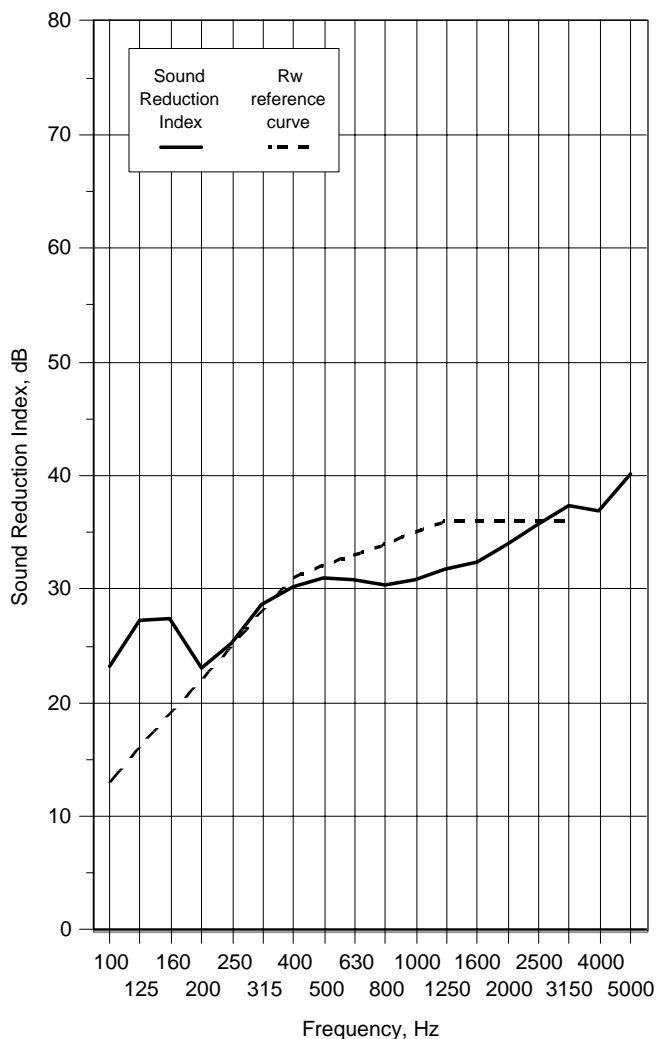

Rating according to BS EN ISO 717-1:1997

Rw(C;Ctr)= **32 (0;-2) dB**

Notes * designates measurement corrected for background
 # designates limit of measurement due to background
 + designates frequency beyond standard and not UKAS accredited

v1.6

Test Number :	121	Air temperature:	18.6 °C
Client:	Norsound Ltd	Air humidity:	71 %
Test Date:	07/07/2008	Receiving room volume	300 m3
Sample height:	2.119 m	Source room volume:	115 m3
Sample width:	1.004 m	Sample weight:	25.9 kg/m2
Product	Single leaf Strebord 44. Glazing=Reference panel (as door leaf)		
Identification:	Fully caulked		

Freq f Hz	Sound Reduction Index, dB	
	1/3 Oct	1/1 Oct
50+	23.0	21.9
63+	21.7	
80+	21.3	
100	22.9	25.9
125	28.5	
160	29.7	
200	27.0	28.9
250	28.8	
315	32.4	
400	34.0	34.9
500	35.6	
630	35.4	
800	34.3	32.7
1000	32.5	
1250	31.7	
1600	32.4	34.0
2000	34.3	
2500	36.2	
3150	38.2	38.4
4000	39.2	
5000	37.9	
6300+	39.9	41.5
8000+	41.8	
10000+	43.6	
Average 100-3150	32.1	

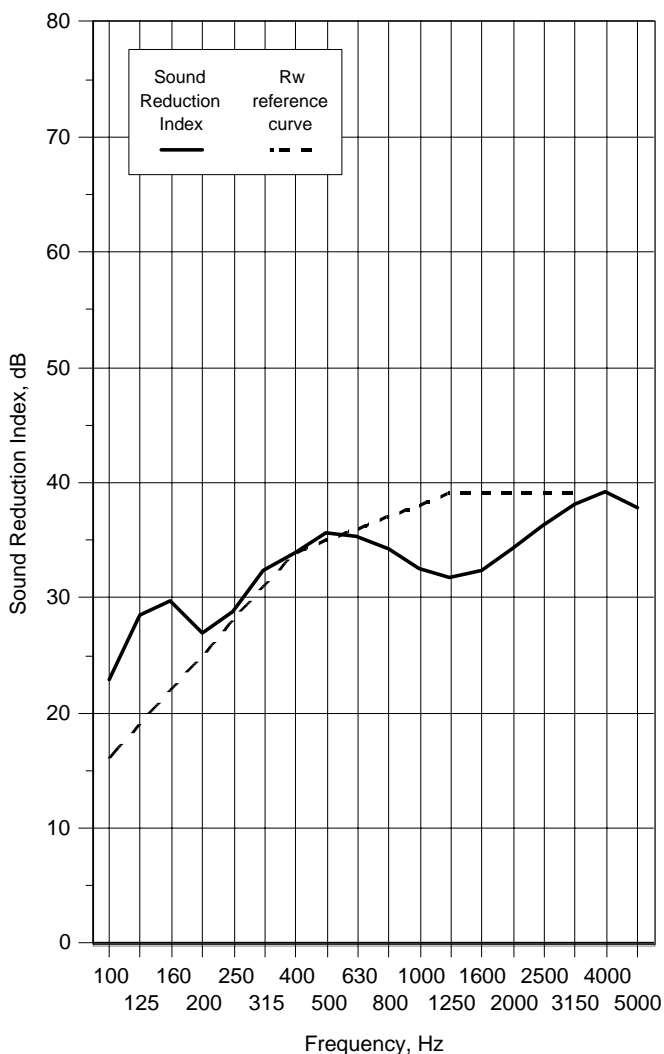

Rating according to BS EN ISO 717-1:1997

Rw(C;Ctr)= **35 (-1;-3)** dB

Notes * designates measurement corrected for background
 # designates limit of measurement due to background
 + designates frequency beyond standard and not UKAS accredited

v1.6

Test Number : 124 **Air temperature:** 17.8 °C
Client: Norsound Ltd **Air humidity:** 65 %
Test Date: 08/07/2008 **Receiving room volume** 300 m3
Sample height: 2.119 m **Source room volume:** 115 m3
Sample width: 1.004 m **Sample weight:** 25.9 kg/m2
Product Single leaf Strebord 44. Glazing=Reference panel (as door leaf)
Identification: Threshold=810
 Head, hanging jamb & closing jamb=710

Freq f Hz	Sound Reduction Index, dB	
	1/3 Oct	1/1 Oct
50+	26.1	24.4
63+	26.6	
80+	22.0	
100	24.6	26.4
125	26.6	
160	29.0	
200	27.8	29.4
250	29.4	
315	31.8	
400	32.7	33.5
500	34.0	
630	34.0	
800	32.7	31.5
1000	31.5	
1250	30.6	
1600	31.0	32.2
2000	32.1	
2500	33.9	
3150	35.7	35.8
4000	35.9	
5000	35.6	
6300+	37.9	39.6
8000+	39.8	
10000+	41.9	
Average 100-3150	31.1	

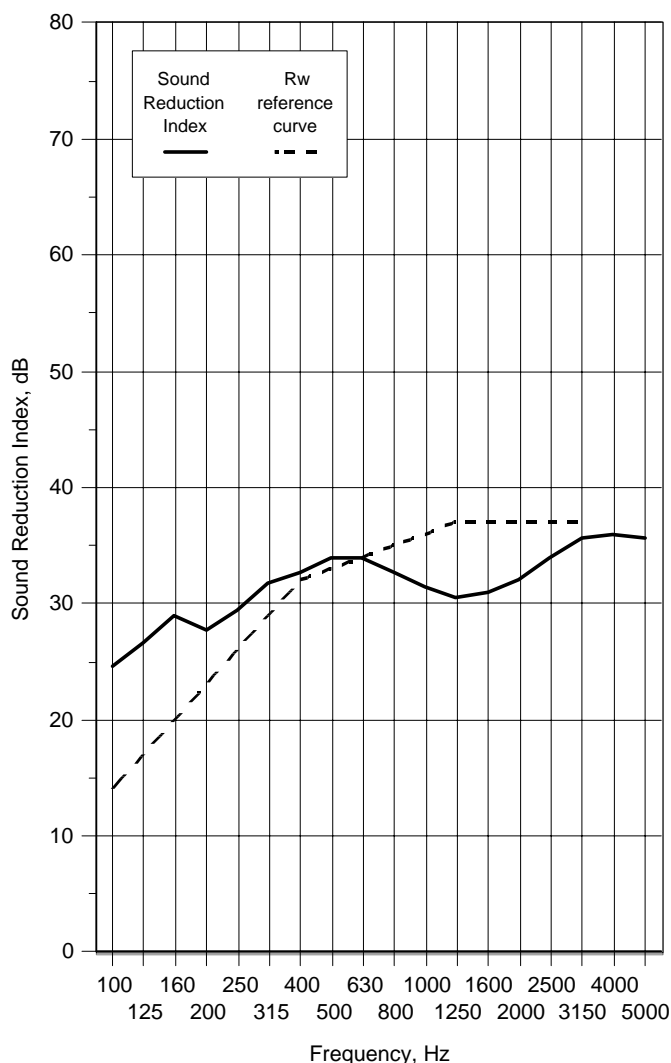

Rating according to BS EN ISO 717-1:1997

Rw(C;Ctr)= **33 (-1;-2)** dB

Notes * designates measurement corrected for background

designates limit of measurement due to background

+ designates frequency beyond standard and not UKAS accredited

v1.6

Test Number :	125	Air temperature:	17.8 °C
Client:	Norsound Ltd	Air humidity:	65 %
Test Date:	08/07/2008	Receiving room volume	300 m ³
Sample height:	2.119 m	Source room volume:	115 m ³
Sample width:	1.004 m	Sample weight:	24 kg/m ²
Product	Single leaf Strebord 44		
Identification:	Glazing=6mm Pyroshield (25% of door leaf area)		
	Threshold=810		
	Head, hanging jamb & closing jamb=710		

Freq f Hz	Sound Reduction Index, dB	
	1/3 Oct	1/1 Oct
50+	25.0	22.9
63+	25.7	
80+	20.3	
100	23.4	25.3
125	25.1	
160	28.7	
200	27.2	28.7
250	28.8	
315	30.9	
400	32.1	33.0
500	33.5	
630	33.7	
800	33.2	32.2
1000	32.4	
1250	31.3	
1600	31.4	32.1
2000	31.6	
2500	33.7	
3150	35.5	35.7
4000	35.7	
5000	36.1	
6300+	38.5	39.9
8000+	40.1	
10000+	41.7	
Average 100-3150	30.8	

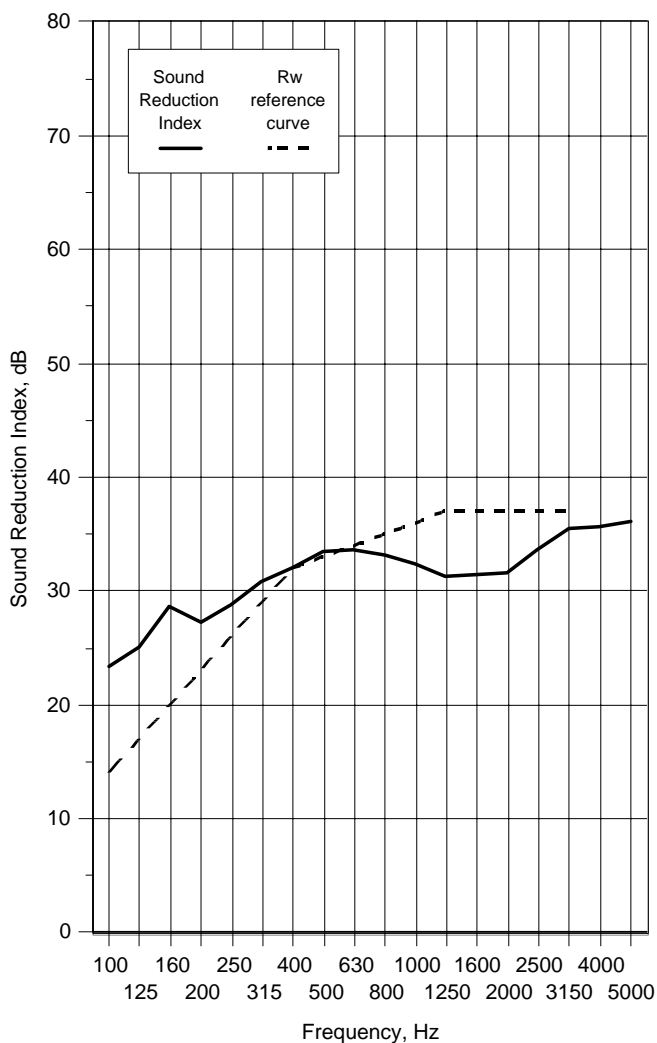

Rating according to BS EN ISO 717-1:1997

Rw(C;Ctr)= **33 (-1;-2)** dB

Notes * designates measurement corrected for background
 # designates limit of measurement due to background
 + designates frequency beyond standard and not UKAS accredited

v1.6

Test Number : 126 **Air temperature:** 17.8 °C
Client: Norsound Ltd **Air humidity:** 65 %
Test Date: 08/07/2008 **Receiving room volume** 300 m3
Sample height: 2.119 m **Source room volume:** 115 m3
Sample width: 1.004 m **Sample weight:** 25.8 kg/m2
Product Single leaf Strebord 44
Identification: Glazing=10mm Pyrodur (25% of door leaf area)
 Threshold=810
 Head, hanging jamb & closing jamb=710

Freq f Hz	Sound Reduction Index, dB	
	1/3 Oct	1/1 Oct
50+	26.2	24.0
63+	25.8	
80+	21.5	
100	24.7	26.0
125	25.7	
160	28.4	
200	27.8	29.2
250	29.4	
315	31.2	
400	32.1	33.3
500	33.9	
630	34.1	
800	32.8	32.1
1000	32.5	
1250	31.2	
1600	31.8	32.9
2000	32.8	
2500	34.7	
3150	36.7	36.7
4000	36.7	
5000	36.7	
6300+	39.2	40.5
8000+	40.8	
10000+	41.9	
Average 100-3150	31.2	

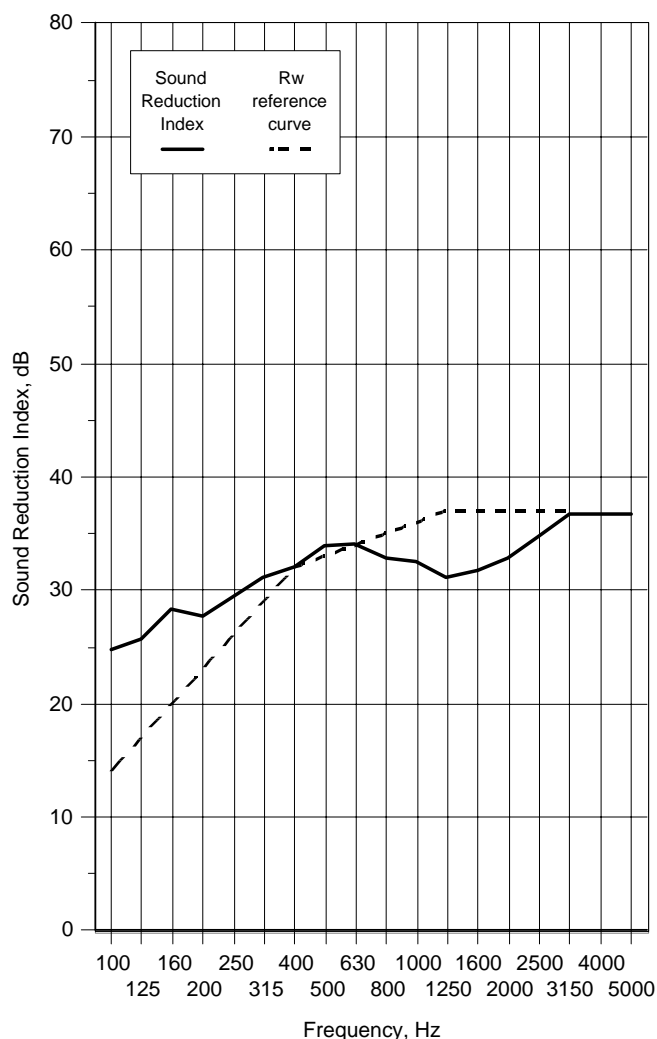

Rating according to BS EN ISO 717-1:1997

Rw(C;Ctr)= **33 (0;-1)** dB

Notes * designates measurement corrected for background

designates limit of measurement due to background

+ designates frequency beyond standard and not UKAS accredited

v1.6

Test Number :	127	Air temperature:	17.8 °C
Client:	Norsound Ltd	Air humidity:	65 %
Test Date:	08/07/2008	Receiving room volume	300 m3
Sample height:	2.119 m	Source room volume:	115 m3
Sample width:	1.004 m	Sample weight:	25.8 kg/m2
Product	Single leaf Strebord 44		
Identification:	Glazing=10mm Pyrodur (25% of door leaf area)		
	Threshold=810 + 650A		
	Head, hanging jamb & closing jamb=710		

Freq f Hz	Sound Reduction Index, dB	
	1/3 Oct	1/1 Oct
50+	26.6	25.2
63+	25.8	
80+	23.8	27.1
100	25.3	
125	27.5	
160	29.6	29.8
200	28.1	
250	30.2	
315	32.0	
400	33.7	34.8
500	35.2	
630	35.8	
800	34.8	
1000	33.1	
1250	31.8	33.0
1600	32.4	
2000	33.3	
2500	35.0	33.4
3150	37.1	
4000	38.4	
5000	38.1	
6300+	39.9	37.8
8000+	41.2	
10000+	43.3	
Average 100-3150	32.2	41.3

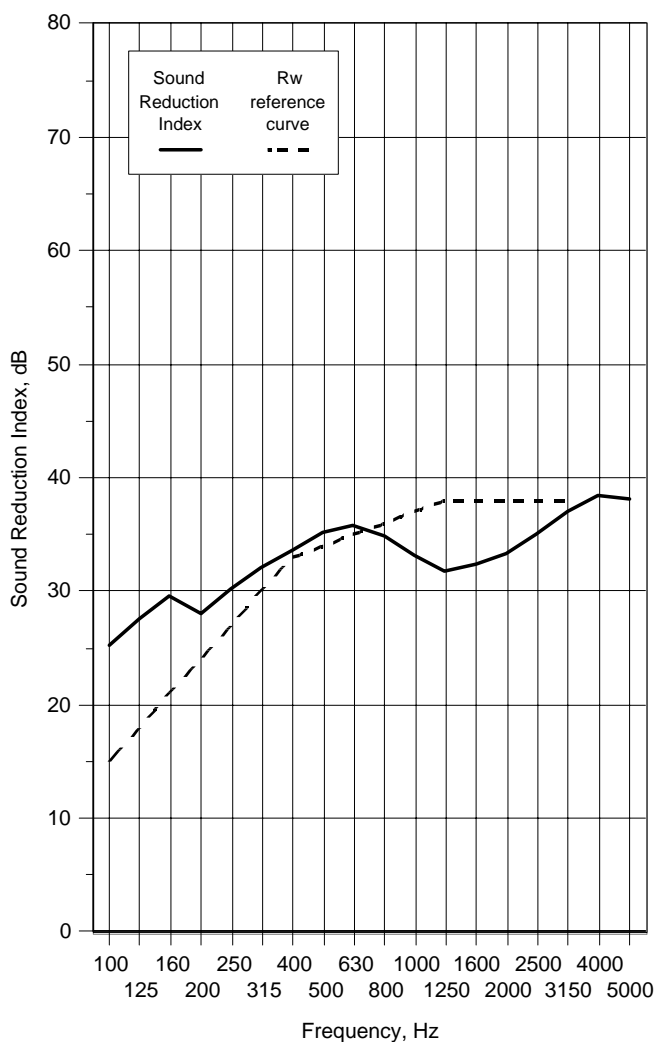

Rating according to BS EN ISO 717-1:1997

Rw(C;Ctr)= **34 (-1;-1)** dB

Notes * designates measurement corrected for background
 # designates limit of measurement due to background
 + designates frequency beyond standard and not UKAS accredited

v1.6

Test Number : 128 **Air temperature:** 17.8 °C
Client: Norsound Ltd **Air humidity:** 65 %
Test Date: 08/07/2008 **Receiving room volume:** 300 m³
Sample height: 2.119 m **Source room volume:** 115 m³
Sample width: 1.004 m **Sample weight:** 28.6 kg/m²
Product: Single leaf Strebord 44
Identification: Glazing=15mm Pyrostop (25% of door leaf area)
Threshold=810 + 650A
Head, hanging jamb & closing jamb=710

Freq f Hz	Sound Reduction Index, dB	
	1/3 Oct	1/1 Oct
50+	27.9	26.7
63+	27.4	
80+	25.3	
100	26.1	27.9
125	28.4	
160	29.8	
200	28.5	30.2
250	30.4	
315	32.7	
400	33.9	35.1
500	35.6	
630	36.1	
800	34.7	32.9
1000	32.7	
1250	31.8	
1600	32.8	33.9
2000	33.7	
2500	35.7	
3150	37.6	38.2
4000	38.9	
5000	38.2	
6300+	40.1	41.5
8000+	41.6	
10000+	43.5	
Average 100-3150	32.5	

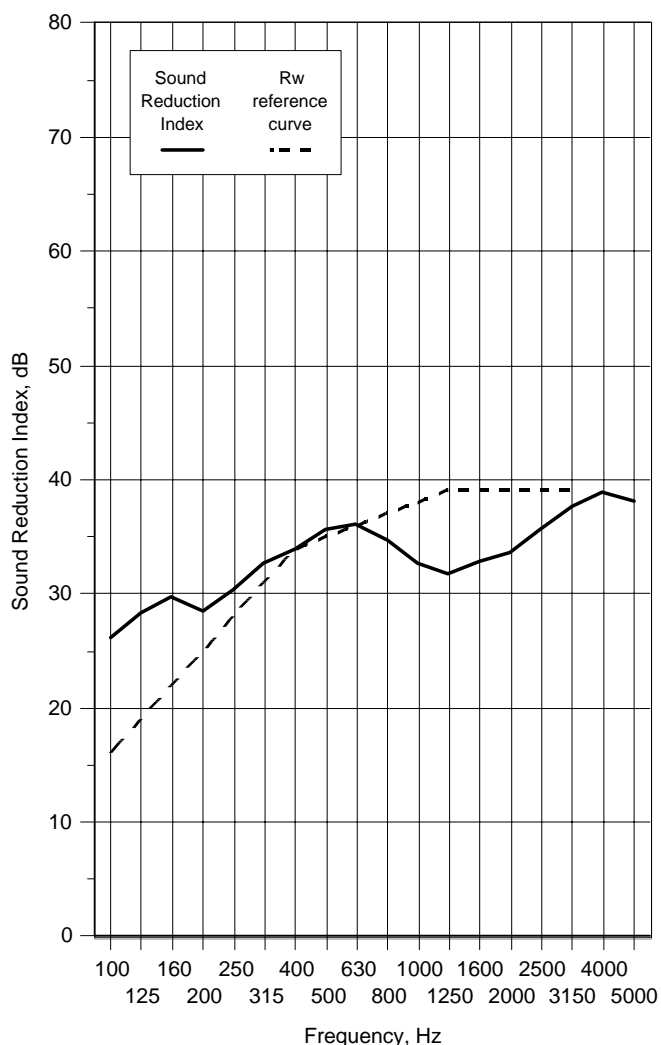

Rating according to BS EN ISO 717-1:1997

Rw(C;Ctr)= **35 (-1;-2)** dB

Notes * designates measurement corrected for background

designates limit of measurement due to background

+ designates frequency beyond standard and not UKAS accredited

v1.6

Test Number : 129 **Air temperature:** 17.8 °C
Client: Norsound Ltd **Air humidity:** 65 %
Test Date: 08/07/2008 **Receiving room volume** 300 m3
Sample height: 2.119 m **Source room volume:** 115 m3
Sample width: 1.004 m **Sample weight:** 30.5 kg/m2
Product Single leaf Strebord 44
Identification: Glazing=16.8mm Optilam-Phon (25% of door leaf area)
Threshold=810 + 650A
Head, hanging jamb & closing jamb=710

Freq f Hz	Sound Reduction Index, dB	
	1/3 Oct	1/1 Oct
50+	29.4	27.3
63+	28.0	
80+	25.5	
100	26.2	27.7
125	28.1	
160	29.3	
200	28.9	30.4
250	30.4	
315	32.8	
400	34.3	35.4
500	35.9	
630	36.3	
800	35.1	33.4
1000	33.3	
1250	32.3	
1600	33.0	34.0
2000	33.8	
2500	35.6	
3150	37.7	38.3
4000	39.0	
5000	38.4	
6300+	40.0	41.5
8000+	41.8	
10000+	43.3	
Average 100-3150	32.7	

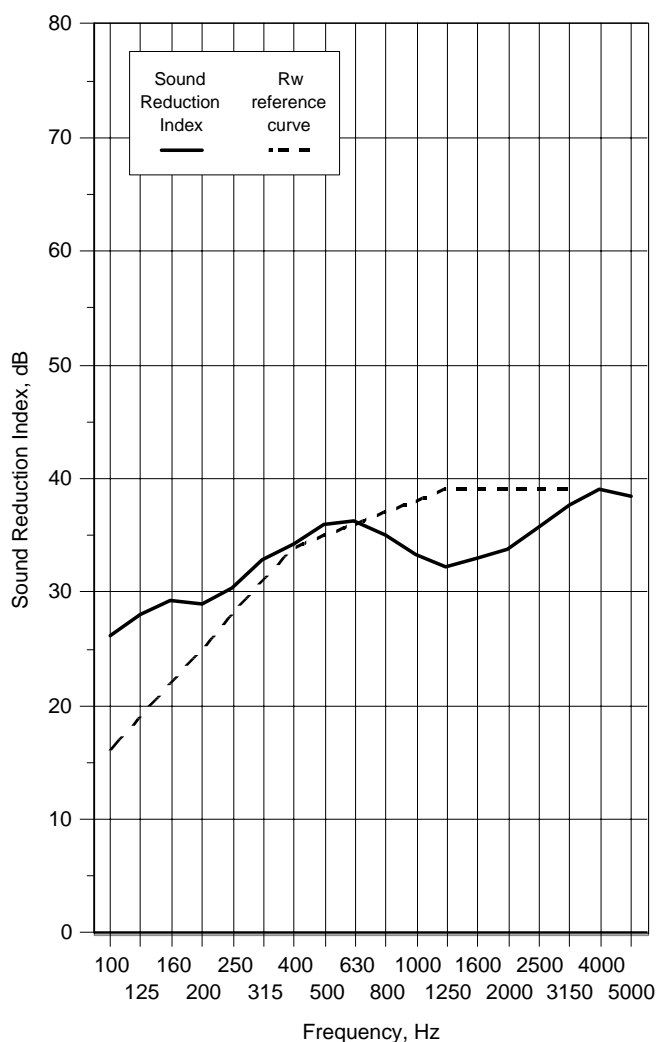

Rating according to BS EN ISO 717-1:1997

Rw(C;Ctr)= **35 (-1;-2)** dB

Notes * designates measurement corrected for background

designates limit of measurement due to background

+ designates frequency beyond standard and not UKAS accredited

v1.6

Test Number :	130	Air temperature:	17.9 °C
Client:	Norsound Ltd	Air humidity:	73 %
Test Date:	08/07/2008	Receiving room volume	300 m3
Sample height:	2.119 m	Source room volume:	115 m3
Sample width:	1.004 m	Sample weight:	21 kg/m2
Product	Single leaf Flamebreak 430		
Identification:	Glazing=6mm Pyroshield (25% of door leaf area) Fully caulked		

Freq f Hz	Sound Reduction Index, dB	
	1/3 Oct	1/1 Oct
50+	23.6	19.0
63+	24.7	
80+	15.2	
100	18.9	21.8
125	23.0	
160	26.7	
200	26.6	28.2
250	28.7	
315	30.2	
400	31.2	32.6
500	33.3	
630	33.9	
800	34.1	34.2
1000	34.2	
1250	34.4	
1600	31.9	31.2
2000	29.7	
2500	32.4	
3150	36.5	38.9
4000	39.7	
5000	43.0	
6300+	45.4	46.3
8000+	46.7	
10000+	47.0	
Average 100-3150	30.4	

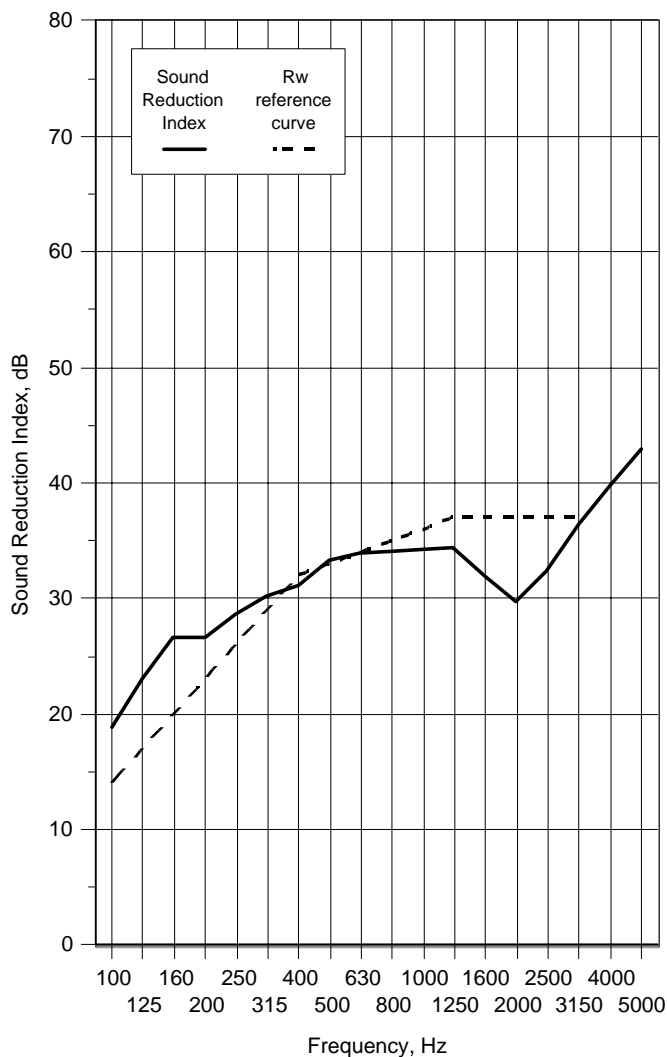

Rating according to BS EN ISO 717-1:1997

Rw(C;Ctr)= **33 (-1;-2)** dB

Notes * designates measurement corrected for background

designates limit of measurement due to background

+ designates frequency beyond standard and not UKAS accredited

v1.6

Test Number :	131	Air temperature:	18 °C
Client:	Norsound Ltd	Air humidity:	65 %
Test Date:	08/07/2008	Receiving room volume	300 m ³
Sample height:	2.119 m	Source room volume:	115 m ³
Sample width:	1.004 m	Sample weight:	21 kg/m ²
Product	Single leaf Flamebreak 430		
Identification:	Glazing=6mm Pyroshield (50% of door leaf area)		
	Threshold=810		
	Head, hanging jamb & closing jamb=710		

Freq f Hz	Sound Reduction Index, dB	
	1/3 Oct	1/1 Oct
50+	22.8	20.1
63+	23.1	
80+	17.2	
100	21.0	23.0
125	23.2	
160	26.0	
200	26.1	27.8
250	28.2	
315	30.0	
400	30.2	31.6
500	32.4	
630	32.8	
800	32.4	32.7
1000	32.6	
1250	33.0	
1600	30.6	29.8
2000	28.3	
2500	31.1	
3150	33.9	36.4
4000	37.0	
5000	40.6	
6300+	42.4	43.5
8000+	44.0	
10000+	44.2	
Average 100-3150	29.5	

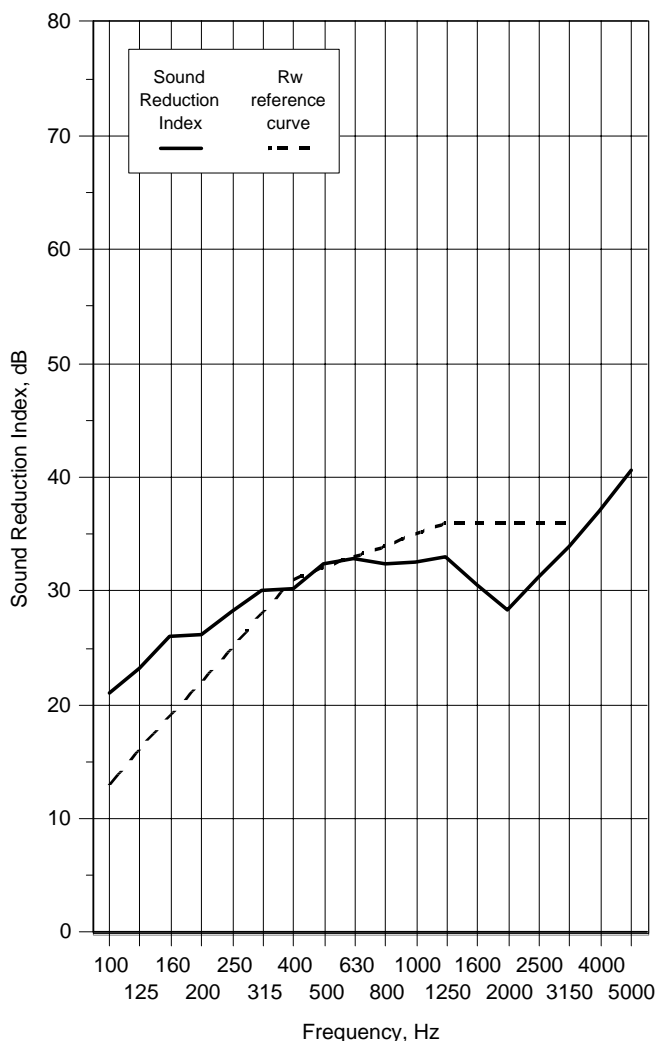

Rating according to BS EN ISO 717-1:1997

Rw(C;Ctr)= **32 (-1;-2)** dB

Notes * designates measurement corrected for background

designates limit of measurement due to background

+ designates frequency beyond standard and not UKAS accredited

v1.6

Test Number :	132	Air temperature:	18.1 °C
Client:	Norsound Ltd	Air humidity:	65 %
Test Date:	08/07/2008	Receiving room volume	300 m3
Sample height:	2.119 m	Source room volume:	115 m3
Sample width:	1.004 m	Sample weight:	23.4 kg/m2
Product	Single leaf Flamebreak 660. Glazing=Reference panel (as door leaf)		
Identification:	Fully caulked		

Freq f Hz	Sound Reduction Index, dB	
	1/3 Oct	1/1 Oct
50+	24.6	22.1
63+	24.5	
80+	19.3	
100	23.4	25.4
125	25.7	
160	28.2	
200	26.8	28.3
250	28.5	
315	30.3	
400	31.5	32.1
500	32.4	
630	32.4	
800	31.9	32.8
1000	32.5	
1250	34.4	
1600	36.1	37.9
2000	38.4	
2500	40.1	
3150	42.1	43.1
4000	42.9	
5000	44.9	
6300+	45.8	44.6
8000+	45.0	
10000+	43.5	
Average 100-3150	32.2	

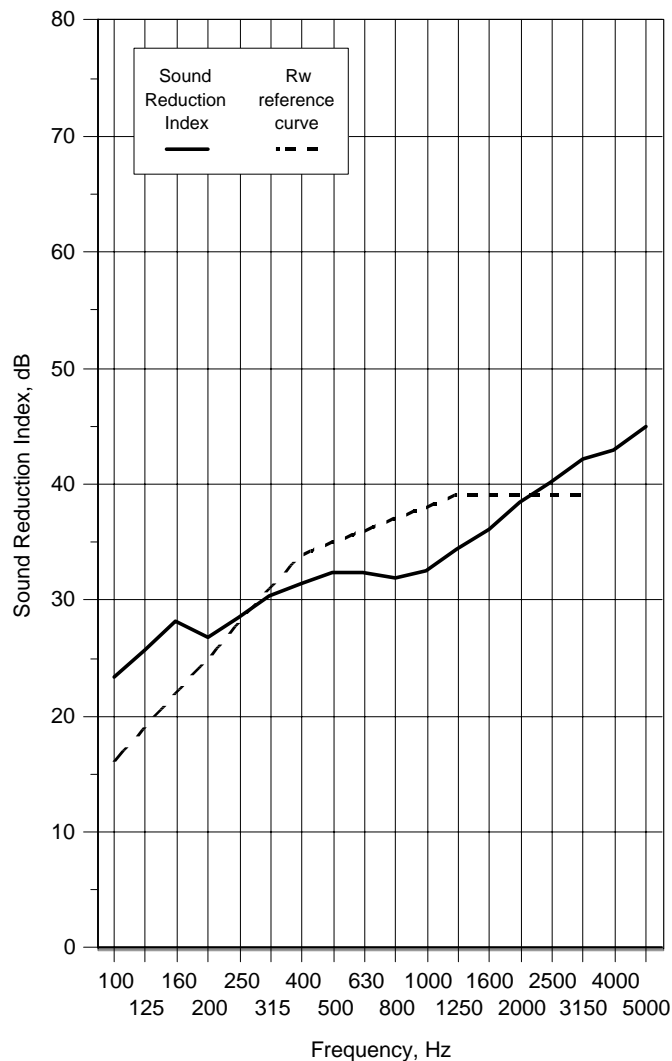

Rating according to BS EN ISO 717-1:1997

Rw(C;Ctr)= **35 (-1;-3)** dB

Notes * designates measurement corrected for background

designates limit of measurement due to background

+ designates frequency beyond standard and not UKAS accredited

v1.6

Test Number :	133	Air temperature:	18.2 °C
Client:	Norsound Ltd	Air humidity:	64 %
Test Date:	08/07/2008	Receiving room volume	300 m3
Sample height:	2.119 m	Source room volume:	115 m3
Sample width:	1.004 m	Sample weight:	19.5 kg/m2
Product	Single leaf Flamebreak 660		
Identification:	Glazing=6mm Pyroshield (25% of door leaf area) Fully caulked		

Freq f Hz	Sound Reduction Index, dB	
	1/3 Oct	1/1 Oct
50+	23.9	22.2
63+	24.1	
80+	19.9	
100	23.1	24.8
125	24.6	
160	28.1	28.2
200	27.0	
250	28.2	
315	30.0	32.7
400	31.9	
500	33.1	
630	33.3	34.1
800	33.4	
1000	33.8	
1250	35.1	35.8
1600	34.9	
2000	35.3	
2500	37.6	42.5
3150	40.5	
4000	43.0	
5000	45.3	46.3
6300+	46.7	
8000+	46.6	
10000+	45.6	
Average 100-3150	31.9	

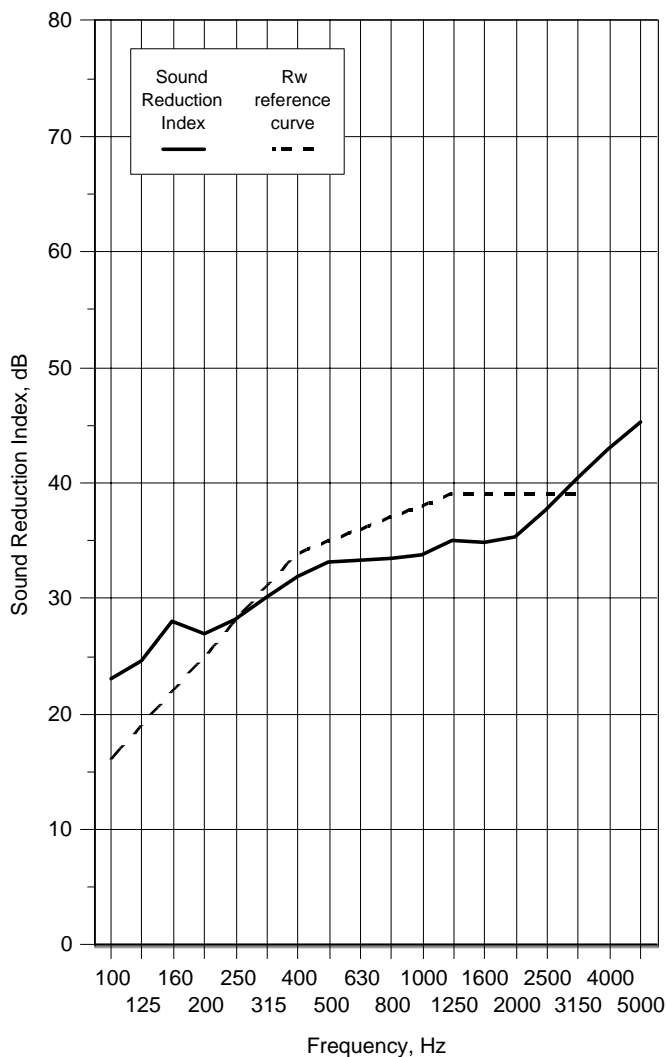

Rating according to BS EN ISO 717-1:1997

Rw(C;Ctr)= **35 (-1;-3) dB**

Notes * designates measurement corrected for background
 # designates limit of measurement due to background
 + designates frequency beyond standard and not UKAS accredited

v1.6

Test Number :	134	Air temperature:	18.2 °C
Client:	Norsound Ltd	Air humidity:	64 %
Test Date:	08/07/2008	Receiving room volume	300 m ³
Sample height:	2.119 m	Source room volume:	115 m ³
Sample width:	1.004 m	Sample weight:	21.4 kg/m ²
Product	Single leaf Flamebreak 660		
Identification:	Glazing=10mm Pyrodur (25% of door leaf area) Fully caulked		

Freq f Hz	Sound Reduction Index, dB	
	1/3 Oct	1/1 Oct
50+	26.3	24.0
63+	25.4	
80+	21.7	
100	24.7	25.9
125	25.3	
160	28.8	
200	27.6	29.0
250	28.9	
315	30.9	
400	32.4	33.4
500	34.1	
630	34.0	
800	33.8	34.3
1000	34.2	
1250	35.1	
1600	36.2	37.9
2000	38.3	
2500	40.1	
3150	42.8	44.2
4000	44.3	
5000	46.1	
6300+	47.0	46.1
8000+	46.3	
10000+	45.2	
Average 100-3150	33.0	

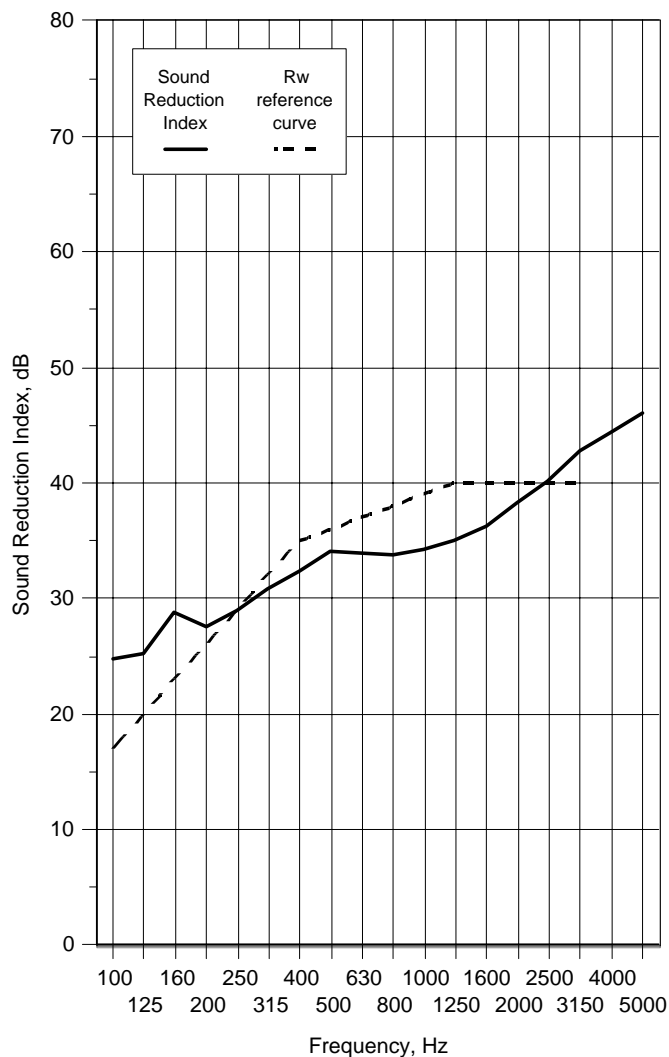

Rating according to BS EN ISO 717-1:1997

Rw(C;Ctr)= **36 (-1;-3) dB**

Notes * designates measurement corrected for background

designates limit of measurement due to background

+ designates frequency beyond standard and not UKAS accredited

v1.6

Test Number :	135	Air temperature:	18.2 °C
Client:	Norsound Ltd	Air humidity:	64 %
Test Date:	08/07/2008	Receiving room volume	300 m3
Sample height:	2.119 m	Source room volume:	115 m3
Sample width:	1.004 m	Sample weight:	24.2 kg/m2
Product	Single leaf Flamebreak 660		
Identification:	Glazing=15mm Pyrostop (25% of door leaf area) Fully caulked		

Freq f Hz	Sound Reduction Index, dB	
	1/3 Oct	1/1 Oct
50+	27.8	25.3
63+	26.5	
80+	23.2	
100	25.8	27.2
125	26.9	
160	29.6	
200	27.4	29.0
250	29.0	
315	31.4	
400	32.8	33.5
500	34.2	
630	33.7	
800	33.6	34.1
1000	33.6	
1250	35.2	
1600	37.4	39.1
2000	39.7	
2500	41.0	
3150	43.4	44.7
4000	44.7	
5000	46.6	
6300+	47.4	46.4
8000+	46.7	
10000+	45.3	
Average 100-3150	33.4	

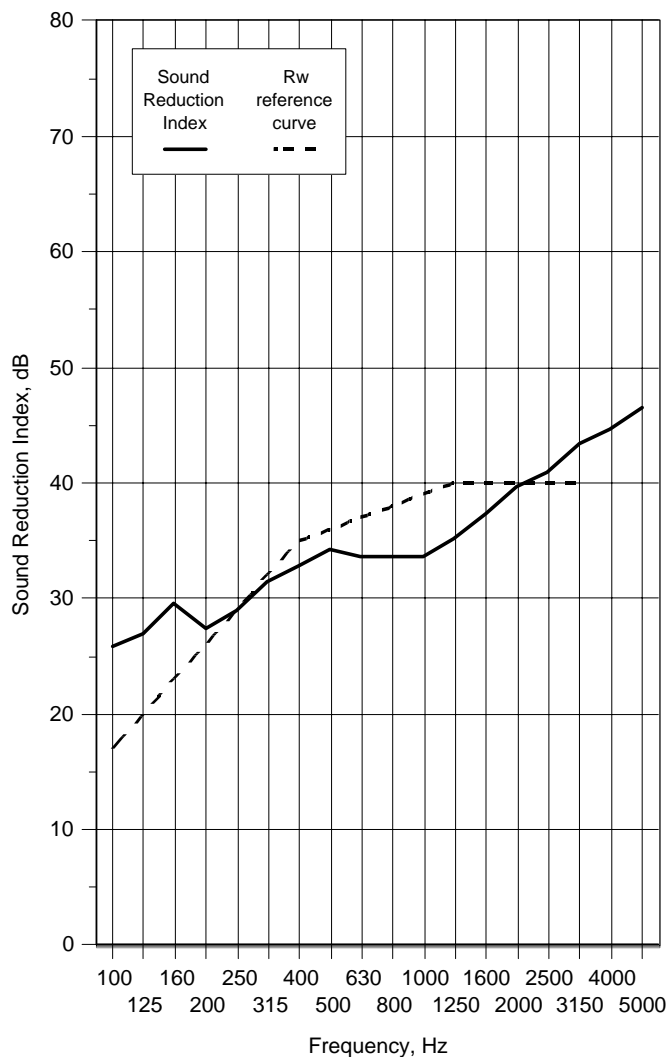

Rating according to BS EN ISO 717-1:1997

Rw(C;Ctr)= **36 (-1;-3)** dB

Notes * designates measurement corrected for background
designates limit of measurement due to background
+ designates frequency beyond standard and not UKAS accredited

v1.6

Test Number :	136	Air temperature:	18.2 °C
Client:	Norsound Ltd	Air humidity:	64 %
Test Date:	08/07/2008	Receiving room volume	300 m3
Sample height:	2.119 m	Source room volume:	115 m3
Sample width:	1.004 m	Sample weight:	26.1 kg/m2
Product	Single leaf Flamebreak 660		
Identification:	Glazing=16.8mm Optilam-Phon (25% of door leaf area) Fully caulked		

Freq f Hz	Sound Reduction Index, dB	
	1/3 Oct	1/1 Oct
50+	28.7	26.3
63+	27.5	
80+	24.1	
100	26.5	27.8
125	27.8	
160	29.7	
200	27.4	29.1
250	29.3	
315	31.7	
400	32.7	33.5
500	34.1	
630	33.7	
800	33.9	34.6
1000	34.1	
1250	36.4	
1600	37.6	39.3
2000	39.8	
2500	41.1	
3150	43.3	44.5
4000	44.4	
5000	46.3	
6300+	46.9	46.0
8000+	46.4	
10000+	44.9	
Average 100-3150	33.7	

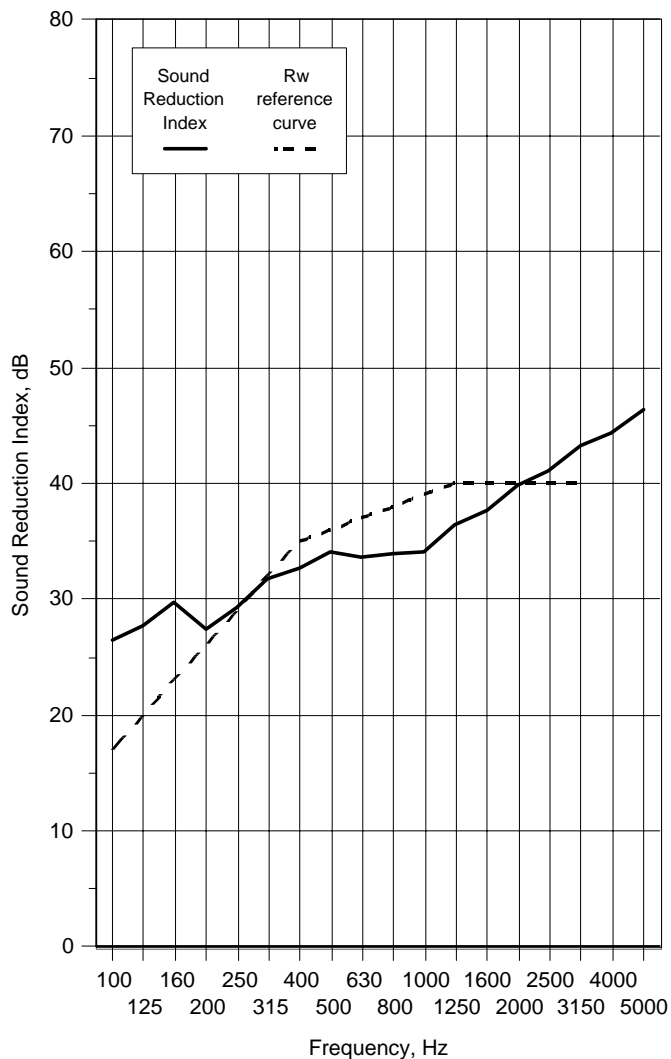

Rating according to BS EN ISO 717-1:1997

Rw(C;Ctr)= **36 (0;-2)** dB

Notes * designates measurement corrected for background
 # designates limit of measurement due to background
 + designates frequency beyond standard and not UKAS accredited

v1.6

Test Number :	137	Air temperature:	18.2 °C
Client:	Norsound Ltd	Air humidity:	64 %
Test Date:	08/07/2008	Receiving room volume	300 m3
Sample height:	2.119 m	Source room volume:	115 m3
Sample width:	1.004 m	Sample weight:	26.1 kg/m2
Product	Single leaf Flamebreak 660		
Identification:	Glazing=16.8mm Optilam-Phon (25% of door leaf area)		
	Threshold=810		
	Head, hanging jamb & closing jamb=710		

Freq f Hz	Sound Reduction Index, dB	
	1/3 Oct	1/1 Oct
50+	28.6	25.0
63+	27.4	
80+	22.0	
100	25.1	26.5
125	27.0	
160	28.0	
200	27.3	29.1
250	29.3	
315	31.9	
400	32.0	32.8
500	33.4	
630	33.3	
800	33.0	33.2
1000	32.7	
1250	34.0	
1600	33.2	34.0
2000	33.9	
2500	35.1	
3150	37.4	38.7
4000	39.5	
5000	39.5	
6300+	40.7	41.6
8000+	42.6	
10000+	41.8	
Average 100-3150	31.7	

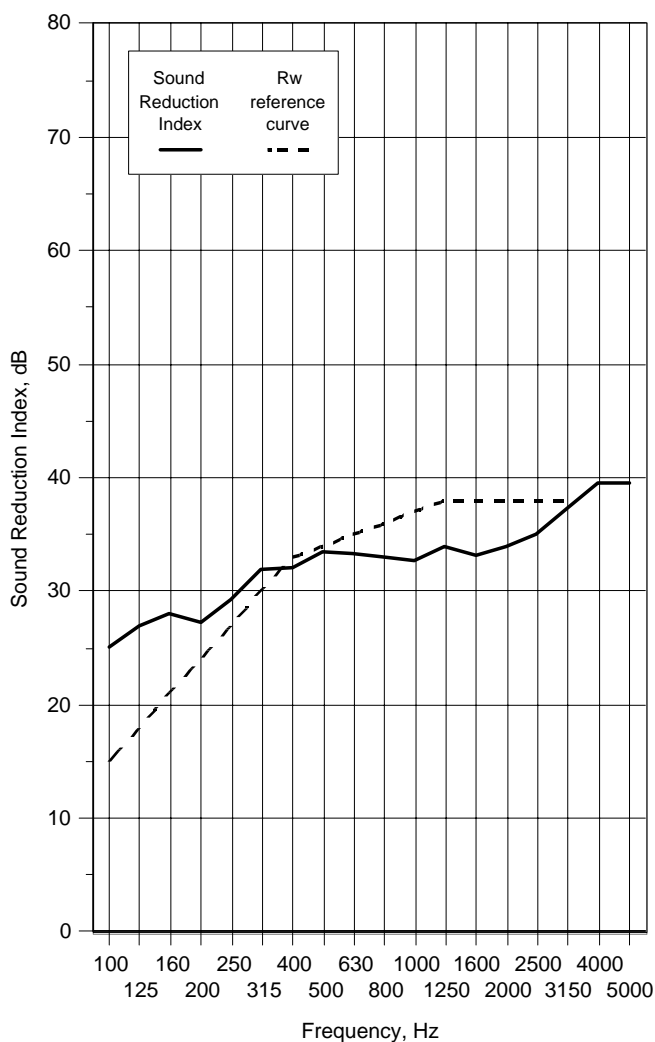

Rating according to BS EN ISO 717-1:1997

Rw(C;Ctr)= **34 (-1;-2) dB**

Notes * designates measurement corrected for background
 # designates limit of measurement due to background
 + designates frequency beyond standard and not UKAS accredited

v1.6

Test Number :	138	Air temperature:	18.2 °C
Client:	Norsound Ltd	Air humidity:	64 %
Test Date:	08/07/2008	Receiving room volume	300 m3
Sample height:	2.119 m	Source room volume:	115 m3
Sample width:	1.004 m	Sample weight:	26.1 kg/m2
Product	Single leaf Flamebreak 660		
Identification:	Glazing=16.8mm Optilam-Phon (25% of door leaf area)		
	Threshold=810 + 650A		
	Head, hanging jamb & closing jamb=710		

Freq f Hz	Sound Reduction Index, dB	
	1/3 Oct	1/1 Oct
50+	28.3	26.1
63+	26.9	
80+	24.1	
100	26.6	27.3
125	27.1	
160	28.2	
200	26.9	29.0
250	29.7	
315	31.9	
400	32.0	33.2
500	33.7	
630	34.2	
800	33.4	33.8
1000	33.4	
1250	34.7	
1600	34.0	35.7
2000	36.0	
2500	38.0	
3150	40.0	40.8
4000	41.7	
5000	40.8	
6300+	41.8	42.6
8000+	43.4	
10000+	42.7	
Average 100-3150	32.5	

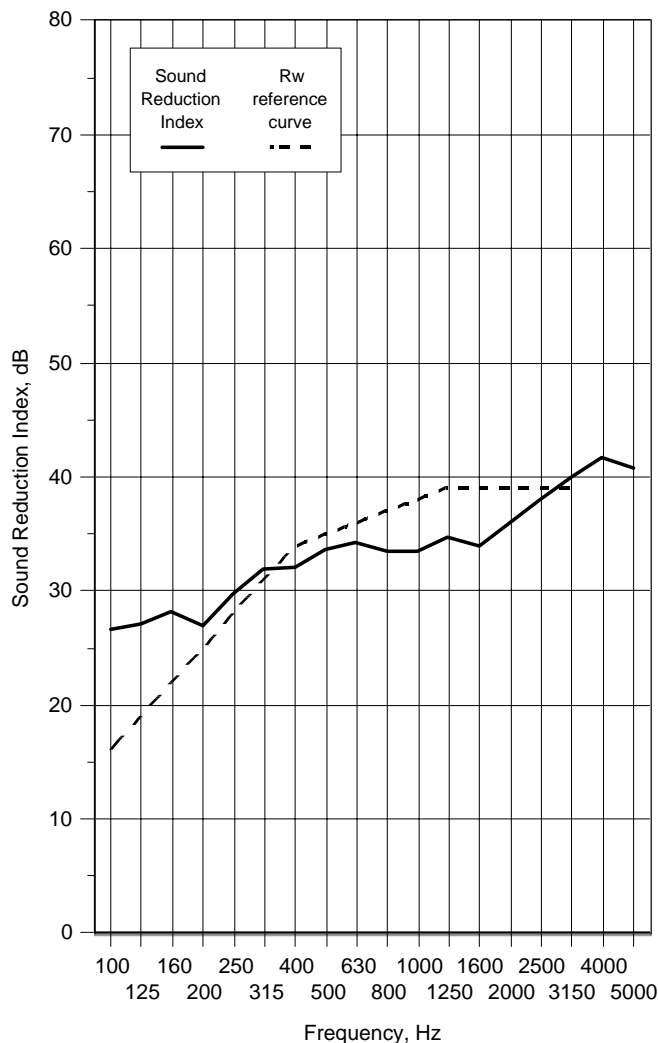

Rating according to BS EN ISO 717-1:1997

Rw(C;Ctr)= **35 (-1;-2)** dB

Notes * designates measurement corrected for background

designates limit of measurement due to background

+ designates frequency beyond standard and not UKAS accredited

v1.6

Test Number : 139 **Air temperature:** 18.2 °C
Client: Norsound Ltd **Air humidity:** 64 %
Test Date: 08/07/2008 **Receiving room volume:** 300 m3
Sample height: 2.119 m **Source room volume:** 115 m3
Sample width: 1.004 m **Sample weight:** 23.4 kg/m2
Product Single leaf Flamebreak 660
Identification: Glazing=Reference panel (as door leaf)
Threshold=810 + 650A
Head, hanging jamb & closing jamb=710

Freq f Hz	Sound Reduction Index, dB	
	1/3 Oct	1/1 Oct
50+	24.8	22.4
63+	24.6	
80+	19.8	
100	23.6	24.9
125	24.4	
160	27.5	
200	26.0	28.0
250	28.6	
315	30.7	
400	30.8	31.6
500	31.8	
630	32.3	
800	31.3	32.0
1000	31.6	
1250	33.2	
1600	33.0	34.7
2000	35.0	
2500	37.1	
3150	39.5	40.2
4000	40.8	
5000	40.4	
6300+	41.4	41.9
8000+	42.7	
10000+	41.8	
Average 100-3150	31.0	

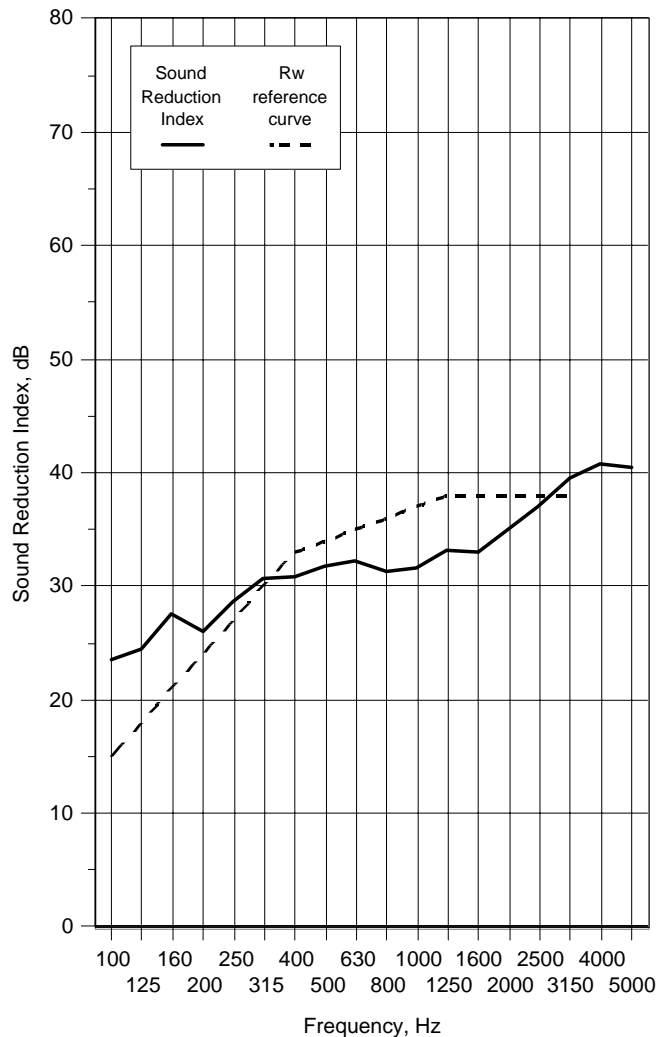

Rating according to BS EN ISO 717-1:1997

Rw(C;Ctr)= **34 (-1;-3) dB**

Notes * designates measurement corrected for background
designates limit of measurement due to background
+ designates frequency beyond standard and not UKAS accredited

v1.6

Test Number :	140	Air temperature:	18.2 °C
Client:	Norsound Ltd	Air humidity:	64 %
Test Date:	08/07/2008	Receiving room volume	300 m3
Sample height:	2.119 m	Source room volume:	115 m3
Sample width:	1.004 m	Sample weight:	19.5 kg/m2
Product	Single leaf Flamebreak 660		
Identification:	Glazing=6mm Pyroshield (25% of door leaf area)		
	Threshold=810 + 650A		
	Head, hanging jamb & closing jamb=710		

Freq f Hz	Sound Reduction Index, dB	
	1/3 Oct	1/1 Oct
50+	24.4	22.4
63+	24.3	
80+	20.0	24.5
100	23.1	
125	23.9	
160	27.5	28.3
200	26.7	
250	28.5	
315	30.7	
400	31.1	32.3
500	32.6	
630	33.4	
800	33.1	33.3
1000	33.0	
1250	33.8	
1600	32.5	
2000	33.4	33.7
2500	35.8	
3150	38.4	39.7
4000	40.6	
5000	40.3	
6300+	41.4	42.4
8000+	43.2	
10000+	42.7	
Average 100-3150	31.1	

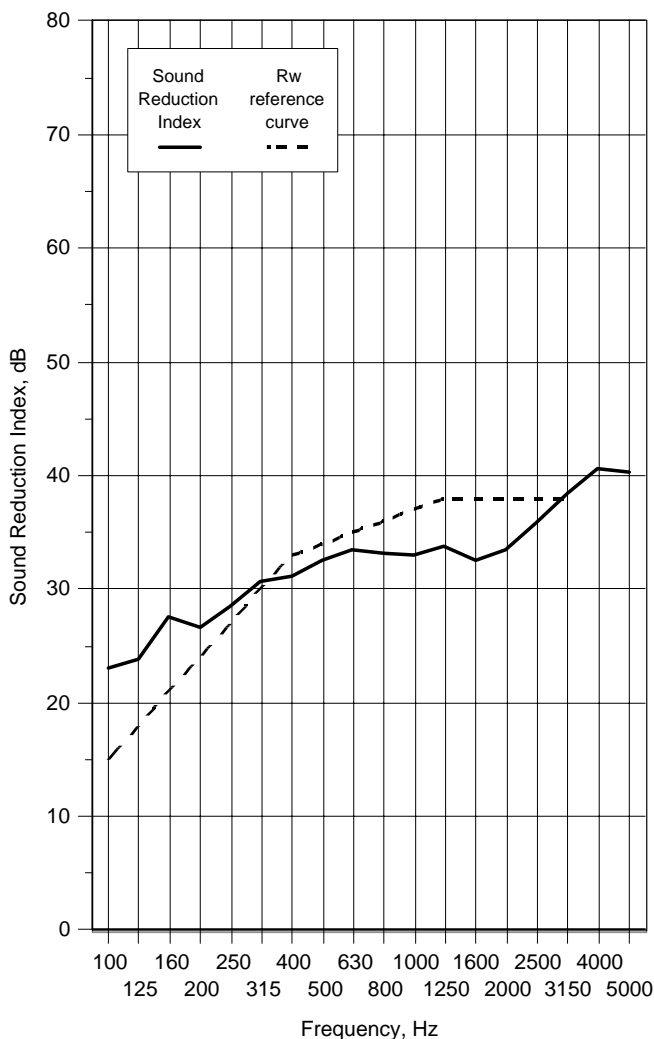

Rating according to BS EN ISO 717-1:1997

Rw(C;Ctr)= **34 (-1;-2) dB**

Notes * designates measurement corrected for background

designates limit of measurement due to background

+ designates frequency beyond standard and not UKAS accredited

v1.6

Test Number : 141 **Air temperature:** 18.2 °C
Client: Norsound Ltd **Air humidity:** 64 %
Test Date: 08/07/2008 **Receiving room volume** 300 m3
Sample height: 2.119 m **Source room volume:** 115 m3
Sample width: 1.004 m **Sample weight:** 21.4 kg/m2
Product Single leaf Flamebreak 660
Identification: Glazing=10mm Pyrodur (25% of door leaf area)
Threshold=810 + 650A
Head, hanging jamb & closing jamb=710

Freq f Hz	Sound Reduction Index, dB	
	1/3 Oct	1/1 Oct
50+	26.3	23.5
63+	24.4	
80+	21.4	
100	24.4	25.7
125	25.3	
160	28.2	
200	27.0	28.8
250	29.1	
315	31.2	
400	32.0	33.0
500	33.3	
630	33.9	
800	33.4	33.4
1000	33.2	
1250	33.8	
1600	33.2	34.9
2000	35.1	
2500	37.2	
3150	39.6	40.4
4000	41.1	
5000	40.6	
6300+	41.8	42.7
8000+	43.6	
10000+	43.1	
Average 100-3150	31.9	

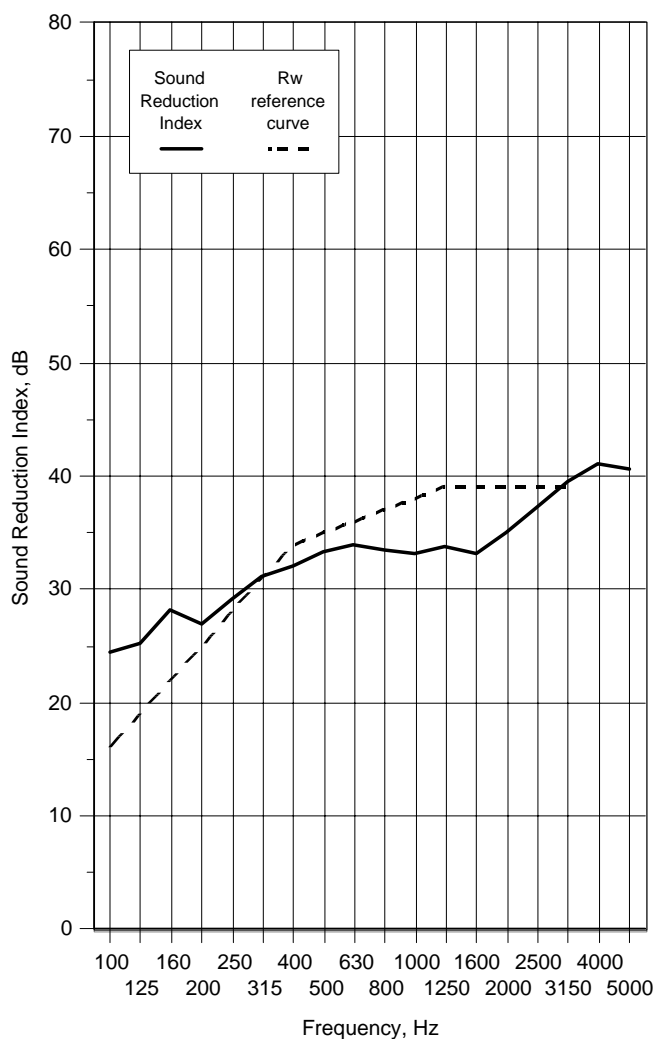

Rating according to BS EN ISO 717-1:1997

Rw(C;Ctr)= **35 (-1;-3)** dB

Notes * designates measurement corrected for background

designates limit of measurement due to background

+ designates frequency beyond standard and not UKAS accredited

v1.6

Test Number : 142 **Air temperature:** 18.2 °C
Client: Norsound Ltd **Air humidity:** 64 %
Test Date: 08/07/2008 **Receiving room volume** 300 m3
Sample height: 2.119 m **Source room volume:** 115 m3
Sample width: 1.004 m **Sample weight:** 24.2 kg/m2
Product Single leaf Flamebreak 660
Identification: Glazing=15mm Pyrostop (25% of door leaf area)
 Threshold=810 + 650A
 Head, hanging jamb & closing jamb=710

Freq f Hz	Sound Reduction Index, dB	
	1/3 Oct	1/1 Oct
50+	27.6	25.5
63+	26.0	
80+	23.7	
100	26.4	27.1
125	26.8	
160	28.6	
200	26.5	28.6
250	29.4	
315	31.6	
400	32.3	33.2
500	33.5	
630	33.9	
800	32.9	33.3
1000	33.0	
1250	34.0	
1600	34.0	35.7
2000	35.9	
2500	37.9	
3150	40.1	40.8
4000	41.5	
5000	41.0	
6300+	41.7	42.6
8000+	43.5	
10000+	42.9	
Average 100-3150	32.3	

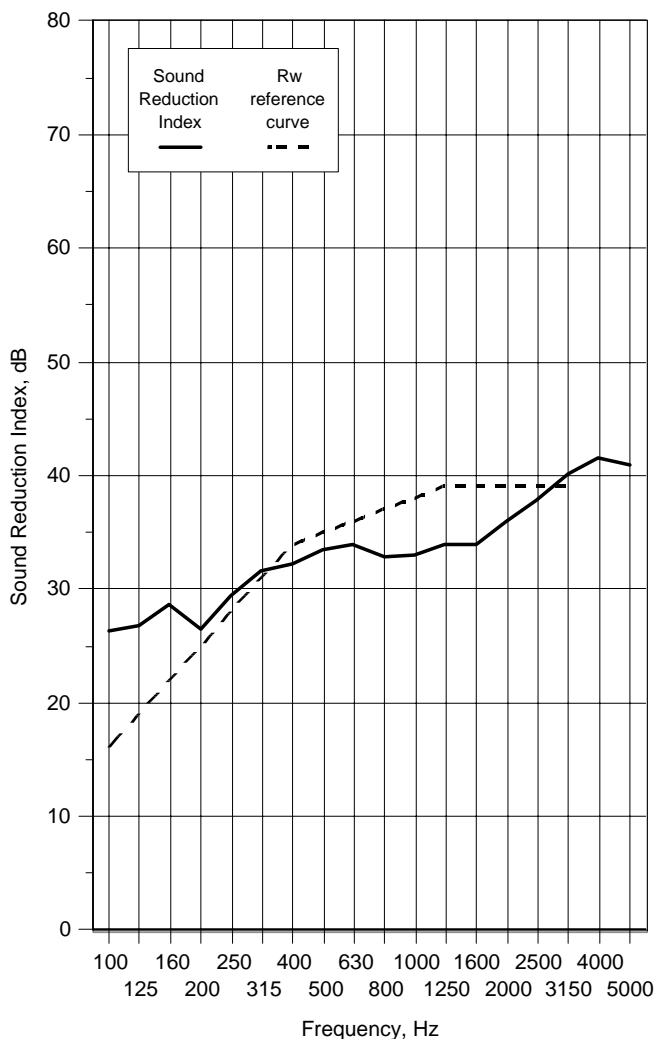

Rating according to BS EN ISO 717-1:1997

Rw(C;Ctr)= **35 (-1;-2) dB**

Notes * designates measurement corrected for background

designates limit of measurement due to background

+ designates frequency beyond standard and not UKAS accredited

v1.6

Test Number : 143 **Air temperature:** 18.2 °C
Client: Norsound Ltd **Air humidity:** 64 %
Test Date: 08/07/2008 **Receiving room volume** 300 m3
Sample height: 2.119 m **Source room volume:** 115 m3
Sample width: 1.004 m **Sample weight:** 23.4 kg/m2
Product Single leaf Flamebreak 660 with letter plate 12in. Gold.
Identification: Threshold=810+650A
 Head, hanging jamb & closing jamb=710

Freq f Hz	Sound Reduction Index, dB	
	1/3 Oct	1/1 Oct
50+	24.6	23.0
63+	25.1	
80+	20.6	
100	23.5	24.4
125	23.7	
160	26.7	
200	25.2	27.1
250	27.9	
315	29.2	
400	29.2	29.4
500	28.7	
630	30.2	
800	31.0	31.8
1000	31.5	
1250	33.1	
1600	32.7	34.2
2000	34.4	
2500	36.3	
3150	38.5	39.1
4000	40.1	
5000	39.0	
6300+	40.3	41.3
8000+	42.0	
10000+	41.6	
Average 100-3150	30.1	

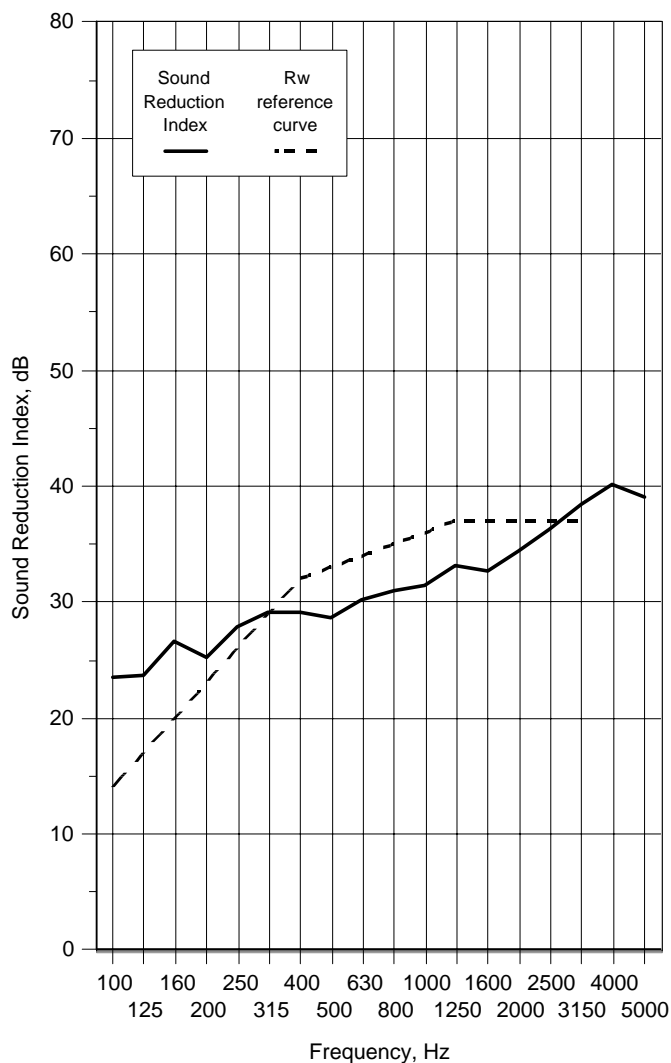

Rating according to BS EN ISO 717-1:1997

Rw(C;Ctr)= **33 (-1;-2)** dB

Notes * designates measurement corrected for background

designates limit of measurement due to background

+ designates frequency beyond standard and not UKAS accredited

v1.6

Test Number : 144 **Air temperature:** 18.2 °C
Client: Norsound Ltd **Air humidity:** 64 %
Test Date: 08/07/2008 **Receiving room volume** 300 m3
Sample height: 2.119 m **Source room volume:** 115 m3
Sample width: 1.004 m **Sample weight:** 23.4 kg/m2
Product Single leaf Flamebreak 660 with letter plate P209G.
Identification: Threshold=810+650A
 Head, hanging jamb & closing jamb=710

Freq f Hz	Sound Reduction Index, dB	
	1/3 Oct	1/1 Oct
50+	25.5	22.1
63+	23.8	
80+	19.4	
100	23.2	24.2
125	23.7	
160	26.5	27.0
200	25.3	
250	27.6	
315	28.8	29.1
400	28.9	
500	28.6	
630	30.0	31.4
800	30.5	
1000	31.1	
1250	33.0	33.8
1600	32.7	
2000	33.8	
2500	35.4	38.7
3150	37.3	
4000	39.5	
5000	39.7	41.5
6300+	40.7	
8000+	42.2	
10000+	41.6	
Average 100-3150	29.8	

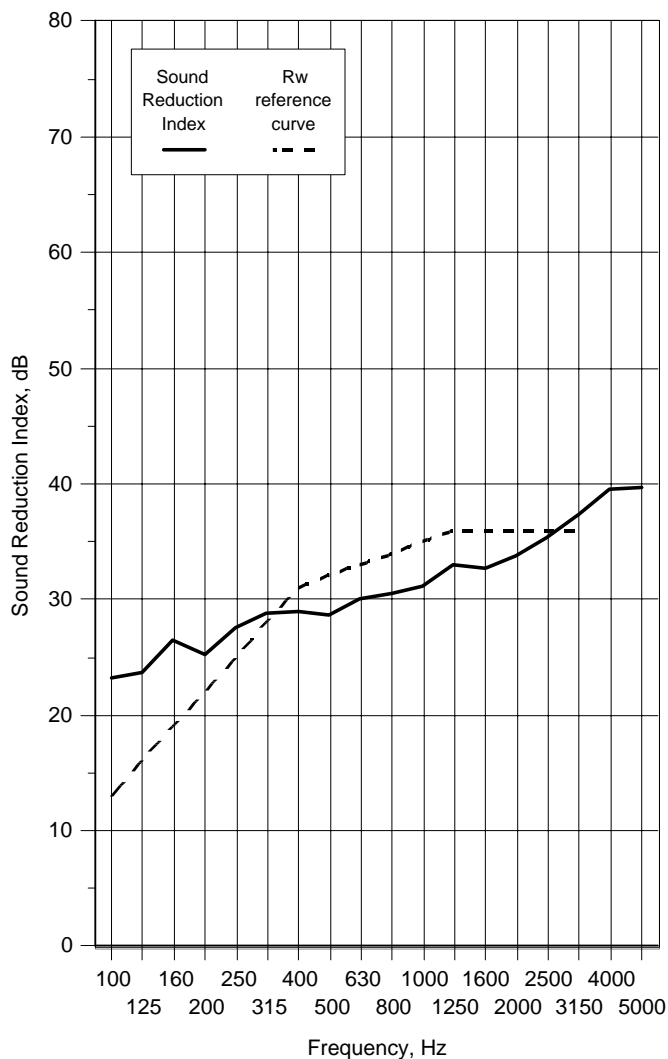

Rating according to BS EN ISO 717-1:1997

Rw(C;Ctr)= **32 (0;-2)** dB

Notes * designates measurement corrected for background
 # designates limit of measurement due to background
 + designates frequency beyond standard and not UKAS accredited

v1.6

Test Number : 145 **Air temperature:** 18.2 °C
Client: Norsound Ltd **Air humidity:** 64 %
Test Date: 08/07/2008 **Receiving room volume:** 300 m³
Sample height: 2.119 m **Source room volume:** 115 m³
Sample width: 1.004 m **Sample weight:** 23.4 kg/m²
Product: Single leaf Flamebreak 660 with letter plate P209G.
Identification: Threshold=810+650A
 Head, hanging jamb & closing jamb=710

Freq f Hz	Sound Reduction Index, dB	
	1/3 Oct	1/1 Oct
50+	25.6	
63+	25.3	22.6
80+	19.7	
100	23.4	
125	23.8	24.5
160	27.2	
200	25.7	
250	27.7	27.3
315	29.1	
400	28.6	
500	29.8	29.9
630	31.8	
800	31.0	
1000	31.8	31.9
1250	33.3	
1600	32.9	
2000	34.5	34.4
2500	36.4	
3150	38.2	
4000	40.0	39.3
5000	40.0	
6300+	41.2	
8000+	42.3	41.7
10000+	41.7	
Average 100-3150	30.3	

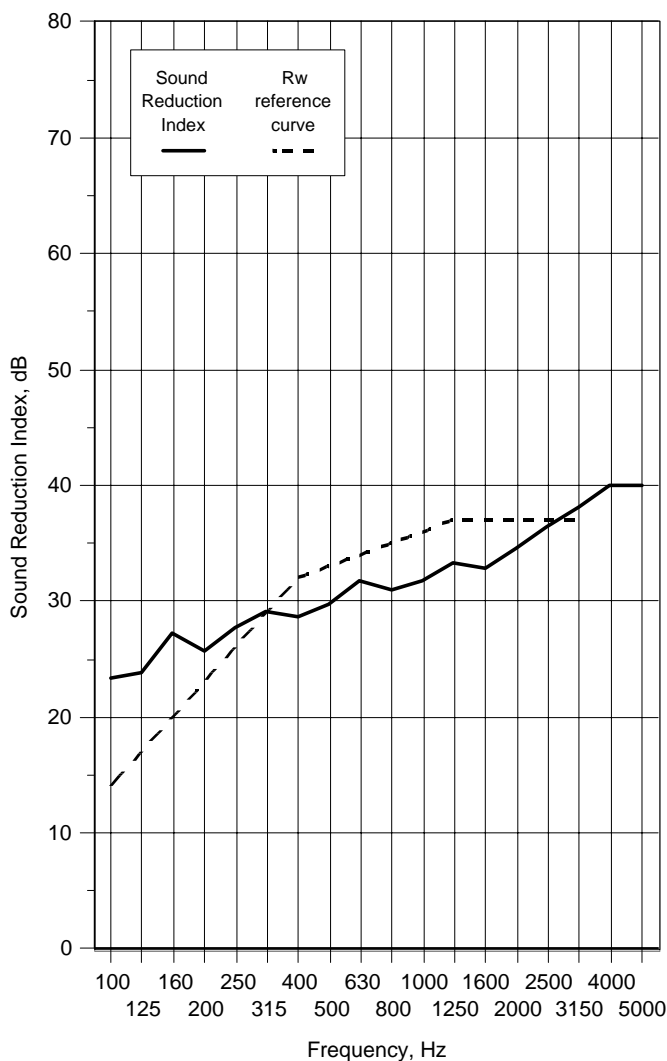

Rating according to BS EN ISO 717-1:1997

Rw(C;Ctr)= **33 (-1;-2) dB**

Notes * designates measurement corrected for background

designates limit of measurement due to background

+ designates frequency beyond standard and not UKAS accredited

v1.6

Test Number : 146 **Air temperature:** 18.2 °C
Client: Norsound Ltd **Air humidity:** 64 %
Test Date: 08/07/2008 **Receiving room volume** 300 m³
Sample height: 2.119 m **Source room volume:** 115 m³
Sample width: 1.004 m **Sample weight:** 23.4 kg/m²
Product Single leaf Flamebreak 660 with GRI-250X250 fire grille
Identification: Threshold=810+650A
 Head, hanging jamb & closing jamb=710

Freq f Hz	Sound Reduction Index, dB	
	1/3 Oct	1/1 Oct
50+	18.1	
63+	15.5	12.9
80+	9.5	
100	13.4	
125	13.4	14.3
160	16.8	
200	16.6	
250	17.8	17.4
315	17.8	
400	16.3	
500	17.1	16.9
630	17.3	
800	16.6	
1000	16.1	16.1
1250	15.6	
1600	15.7	
2000	16.8	16.6
2500	17.6	
3150	18.4	
4000	18.5	18.3
5000	18.2	
6300+	18.0	
8000+	18.1	18.3
10000+	18.9	
Average 100-3150	16.5	

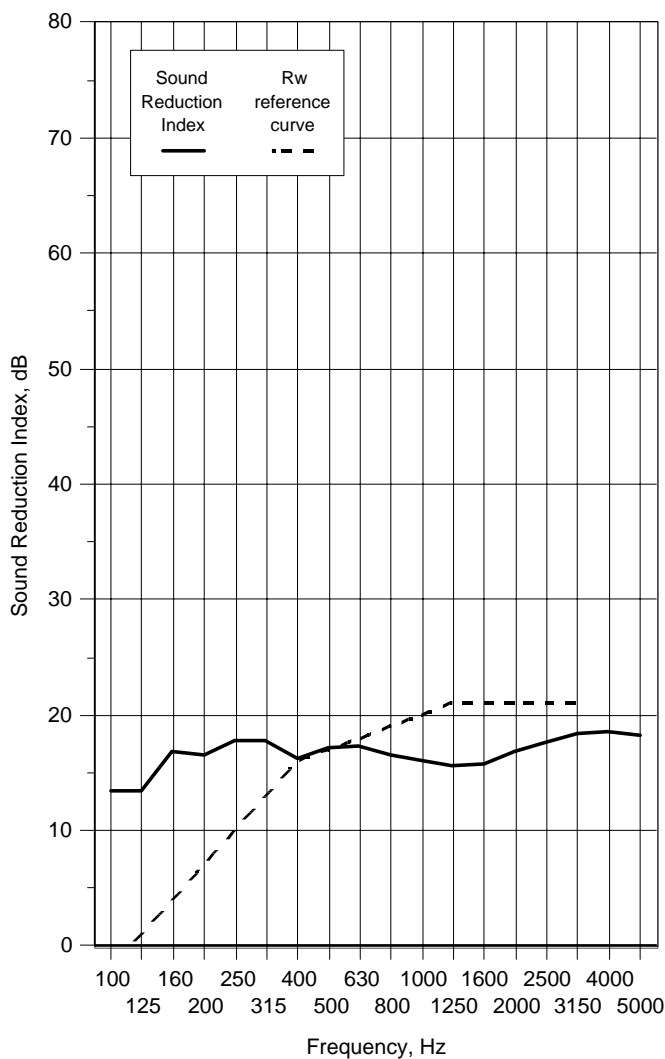

Rating according to BS EN ISO 717-1:1997

Rw(C;Ctr)= **17 (0;-1)** dB

Notes * designates measurement corrected for background

designates limit of measurement due to background

+ designates frequency beyond standard and not UKAS accredited

v1.6

Appendix 4 - Test Details

Flamebreak 430

Flamebreak 430 - 44mm Item No.	Norsound Test Ref.	SRL Test No.	Dwg. Ref	Door Configuration	Door Type	Height	Width	Tcks.	Head	Hanging Jamb	Closing Jamb	Threshold	Meeting Stiles	GLAZING	Fully Caulked	Measured Performance Rw.	NOTES
Flamebreak 430 - Single Leaf - Single Action - Tested with Threshold Blocks.																	
1	44	55	SK/AHP/ 240408/ T046	Single leaf	Flamebreak 430	2040	926	44	FULLY CAULKED					NIL	YES	30dB	Fully caulked test to establish potential maximum performance.
2	46	56	SK/AHP/ 240408/ T047	Single leaf	Flamebreak 430	2040	926	44	NORSOUND 710	NORSOUND 710	NORSOUND 710	NORSOUND 810	n/a	NIL	NO	29dB	NORSOUND 810 housed in Block 1
3	52	57	SK/AHP/ 240408/ T048	Single leaf	Flamebreak 430	2040	926	44	NORSOUND 710	NORSOUND 710	NORSOUND 710	NORSOUND 850 + NORSOUND 650 threshold.	n/a	NIL	NO	30dB	NORSOUND 850 housed in BLOCK 7 used with 650 threshold
Flamebreak 430 - Single Leaf - Single Action - Tested with various glass types																	
4	75	49	SK/AHP/ 240408/ T049	Single leaf	Flamebreak 430	2040	926	44	NORSOUND 710	NORSOUND 710	NORSOUND 710	NORSOUND 810	n/a	6mm Pyroshield	NO	31dB	See SRL Test 55 above for fully caulked performance. Clear glass area = 1570 x 300mm (0.471M ²) = 25% of door leaf area.
5	76	52	SK/AHP/ 240408/ T050	Single leaf	Flamebreak 430	2040	926	44	NORSOUND 710	NORSOUND 710	NORSOUND 710	NORSOUND 810	n/a	7mm Pyrobelite	NO	32dB	See SRL Test 55 above for fully caulked performance. Clear glass area = 1570 x 300mm (0.471M ²) = 25% of door leaf area.
6	77a	48	SK/AHP/ 240408/ T051	Single leaf	Flamebreak 430	2040	926	44	NORSOUND 710	NORSOUND 710	NORSOUND 710	NORSOUND 810	n/a	12mm Pyrobelite	NO	32dB	See SRL Test 55 above for fully caulked performance. Clear glass area = 1570 x 300mm (0.471M ²) = 25% of door leaf area.
7	77b	51	SK/AHP/ 240408/ T052	Single leaf	Flamebreak 430	2040	926	44	NORSOUND 710	NORSOUND 710	NORSOUND 710	NORSOUND 810	n/a	11.5 3Ply PA Res Glass	NO	31dB	See SRL Test 55 above for fully caulked performance. Clear glass area = 1570 x 300mm (0.471M ²) = 25% of door leaf area.
8	78a	50	SK/AHP/ 240408/ T053	Single leaf	Flamebreak 430	2040	926	44	NORSOUND 710	NORSOUND 710	NORSOUND 710	NORSOUND 810	n/a	16mm Pyrobel	NO	32dB	See SRL Test 55 above for fully caulked performance. Clear glass area = 1570 x 300mm (0.471M ²) = 25% of door leaf area.
Flamebreak 430 - Unequal Pair - Single Action																	
9	98b	73	SK/AHP/ 240408/ T054	Unequal Pair	Flamebreak 430	2040	626 + 298	44	FULLY CAULKED					NIL	YES	32dB	Fully caulked test to establish potential maximum performance.
10	98a	72	SK/AHP/ 240408/ T054	Unequal Pair	Flamebreak 430	2040	626 + 298	44	NORSOUND 710	NORSOUND 710	NORSOUND 710	NORSOUND 810 + 810	NORSOUND 720	NIL	NO	30dB	See SRL Test 73 above for fully caulked performance of single leaf doorset. = Rw.32dB.
11	96	69	SK/AHP/ 240408/ T055	Unequal Pair	Flamebreak 430	2040	626 + 298	44	NORSOUND 710	NORSOUND 710	NORSOUND 710	NORSOUND 810 + 810	NORSOUND 720 + NORSOUND 510	NIL	NO	30dB	See SRL Test 73 above for fully caulked performance of single leaf doorset. = Rw.32dB.
12	97	70	SK/AHP/ 240408/ T056	Unequal Pair	Flamebreak 430	2040	626 + 298	44	NORSOUND 710	NORSOUND 710	NORSOUND 710	NORSOUND 810 + 810	2 x NORSOUND 755 + NORSOUND 720	NIL	NO	31dB	See SRL Test 73 above for fully caulked performance of single leaf doorset. = Rw.32dB.
13	98	71	SK/AHP/ 240408/ T057	Unequal Pair	Flamebreak 430	2040	626 + 298	44	NORSOUND 710	NORSOUND 710	NORSOUND 710	NORSOUND 810 + 810	NORSOUND 855 + NORSOUND 855 carrier only + NORSOUND 720	NIL	NO	31dB	See SRL Test 73 above for fully caulked performance of single leaf doorset. = Rw.32dB.
Flamebreak 430 - Single Leaf - Double Action																	
14	104a	112	SK/AHP/ 240408/ T058	Single leaf Double Action	Flamebreak 430	2019	915	44	FULLY CAULKED					NIL	YES	29dB	Fully caulked test to establish potential maximum performance.
15	104	113	SK/AHP/ 240408/ T058	Single leaf Double Action	Flamebreak 430	2019	915	44	2x NORSOUND 720	2x NORSOUND 720	2x NORSOUND 720	2x NORSOUND 855 used with NORSOUND 620 threshold.	n/a	NIL	NO	28dB	Double Action Door.

Flamebreak FF630

Flamebreak FF630 - 44mm Item No.	Norsound Test Ref.	SRL Test No.	Dwg. Ref	Door Configuration	Door Type	Height	Width	Tcks.	Head	Hanging Jamb	Closing Jamb	Threshold	Meeting Stiles	GLAZING	Fully Caulked	Measured Performance Rw.	NOTES
Flamebreak FF630 - Single Leaf - Double Action																	
1	56a	79	Sk/AHP/ 240408/ T059	Single leaf	Flamebreak FF630	2040	926	44	FULLY CAULKED					NIL	YES	30dB	Fully caulked test to establish potential maximum performance. Door construction as Flamebreak 430 but uses MBF facings in lieu of plywood.
2	56	78	Sk/AHP/ 240408/ T059	Single leaf	Flamebreak FF630	2040	926	44	NORSOUND 710	NORSOUND 710	NORSOUND 710	NORSOUND 810	n/a	NIL	NO	29dB	
3	56b	81	Sk/AHP/ 240408/ T060	Single leaf	Flamebreak FF630	2040	926	44	NORSOUND 710	NORSOUND 710	NORSOUND 710	NORSOUND 810	n/a	NIL	NO	29dB	Frame doorstop removed. Performance relying on sealing system only.

Flamebreak 660

Flamebreak 660 - 54mm Item No.	Norsound Test Ref.	SRL Test No.	Dwg. Ref	Door Configuration	Door Type	Height	Width	Tcks.	Head	Hanging Jamb	Closing Jamb	Threshold	Meeting Stiles	Glazing	Fully Caulked	Measured Performance Rw.	NOTES
Flamebreak 660 - Single Leaf - Single Action - Tested with Threshold Blocks.																	
1	23	25	Sk/AHP/240408/ T061	Single leaf	Flamebreak 660	2040	926	54	FULLY CAULKED					NIL	YES	35dB	Fully caulked test to establish potential maximum performance.
2	26	27	Sk/AHP/240408/ T061	Single leaf	Flamebreak 660	2040	926	54	NORSOUND 710	NORSOUND 710	NORSOUND 710	NORSOUND 810	n/a	NIL	NO	32dB	NORSOUND 810 housed in Block 8
3	32	26	Sk/AHP/240408/ T062	Single leaf	Flamebreak 660	2040	926	54	NORSOUND 710	NORSOUND 710	NORSOUND 710	NORSOUND 850 + NORSOUND 650 threshold.	n/a	NIL	NO	34dB	NORSOUND 850 housed in BLOCK 14 used with 650 threshold
Flamebreak 660 - Single Leaf - Single Action - Tested with various glass types																	
4	65	33	Sk/AHP/240408/ T063	Single leaf	Flamebreak 660	2040	926	54	NORSOUND 710	NORSOUND 710	NORSOUND 710	NORSOUND 810	n/a	6mm Pyroshield	NO	33dB	See SRL Test 25 above for fully caulked performance. Clear glass area = 1570 x 300mm (0.471M ²) = 25% of door leaf area.
5	65a	39	Sk/AHP/240408/ T063	Single leaf	Flamebreak 660	2040	926	54	NORSOUND 710	NORSOUND 710	NORSOUND 710	NORSOUND 810	n/a	6mm Pyroshield	NO	33dB	See SRL Test 25 above for fully caulked performance. Clear glass area = 1570 x 300mm (0.471M ²) = 25% of door leaf area. Repeat of NORSOUND Test 65 (SRL Test 33) following adjustment to glass sealing.
6	65b	60	Sk/AHP/240408/ T064	Single leaf	Flamebreak 660	2040	926	54	NORSOUND 710	NORSOUND 710	NORSOUND 710	NORSOUND 810 + NORSOUND 650A threshold.	n/a	6mm Pyroshield	NO	34dB	See SRL Test 25 above for fully caulked performance. Clear glass area = 1570 x 300mm (0.471M ²) = 25% of door leaf area.
7	66	34	Sk/AHP/240408/ T065	Single leaf	Flamebreak 660	2040	926	54	NORSOUND 710	NORSOUND 710	NORSOUND 710	NORSOUND 810	n/a	7mm Pyrobelite	NO	34dB	See SRL Test 25 above for fully caulked performance. Clear glass area = 1570 x 300mm (0.471M ²) = 25% of door leaf area.
8	67a	35	Sk/AHP/240408/ T066	Single leaf	Flamebreak 660	2040	926	54	NORSOUND 710	NORSOUND 710	NORSOUND 710	NORSOUND 810	n/a	12mm Pyrobelite	NO	34dB	See SRL Test 25 above for fully caulked performance. Clear glass area = 1570 x 300mm (0.471M ²) = 25% of door leaf area.
9	67b	36	Sk/AHP/240408/ T066	Single leaf	Flamebreak 660	2040	926	54	NORSOUND 710	NORSOUND 710	NORSOUND 710	NORSOUND 810	n/a	12mm Pyrobelite	NO	34dB	See SRL Test 25 above for fully caulked performance. Clear glass area = 1570 x 300mm (0.471M ²) = 25% of door leaf area. Repeat of NORSOUND Test 67a (SRL Test 35) following adjustment to glass sealing.
10	68a	38	Sk/AHP/240408/ T067	Single leaf	Flamebreak 660	2040	926	54	NORSOUND 710	NORSOUND 710	NORSOUND 710	NORSOUND 810	n/a	11.5 3Ply PA Res Glass	NO	34dB	See SRL Test 25 above for fully caulked performance. Clear glass area = 1570 x 300mm (0.471M ²) = 25% of door leaf area.
Flamebreak 660 - Unequal Pair - Single Action																	
11	88	82	Sk/AHP/240408/ T068	Unequal Pair	Flamebreak 660	2040	626 + 298	54	NORSOUND 710	NORSOUND 710	NORSOUND 710	NORSOUND 810 + 810	NORSOUND 720 + NORSOUND 510	NIL	NO	34dB	See SRL Test 25 above for fully caulked performance of single leaf doorset. = Rw.35dB.
12	88a	83	Sk/AHP/240408/ T069	Unequal Pair	Flamebreak 660	2040	626 + 298	54	NORSOUND 710	NORSOUND 710	NORSOUND 710	NORSOUND 810 + 810	NORSOUND 510	NIL	NO	33dB	See SRL Test 25 above for fully caulked performance of single leaf doorset. = Rw.35dB.
13	89	84	Sk/AHP/240408/ T070	Unequal Pair	Flamebreak 660	2040	626 + 298	54	NORSOUND 710	NORSOUND 710	NORSOUND 710	NORSOUND 810 + 810	2 x NORSOUND 755 + NORSOUND 720	NIL	NO	34dB	See SRL Test 25 above for fully caulked performance of single leaf doorset. = Rw.35dB.
14	90	85	Sk/AHP/240408/ T071	Unequal Pair	Flamebreak 660	2040	626 + 298	54	NORSOUND 710	NORSOUND 710	NORSOUND 710	NORSOUND 810 + 810	NORSOUND 855 + NORSOUND 855 carrier only + NORSOUND 720	NIL	NO	34dB	See SRL Test 25 above for fully caulked performance of single leaf doorset. = Rw.35dB.
Flamebreak 660 - Single Leaf - Double Action																	
15	101a	104	Sk/AHP/240408/ T072	Single leaf	Flamebreak 660	2019	915	54	FULLY CAULKED					NIL	YES	32dB	Fully caulked test to establish potential maximum performance.
16	101	105	Sk/AHP/240408/ T072	Single leaf	Flamebreak 660	2019	915	54	2x NORSOUND 720	2x NORSOUND 720	2x NORSOUND 720	2x NORSOUND 855 used with NORSOUND 620 threshold.	n/a	NIL	NO	30dB	Double Action Door.

Strebord 44 Doors

44 STREBORD Item No.	Norsound Test Ref.	SRL Test No.	Dwg. Ref	Door Configuration	Door Type	Height	Width	Tcks.	Head	Hanging Jamb	Closing Jamb	Threshold	Meeting Stiles	Glazing	Fully Caulked	Measured Performance Rw.	NOTES
Strebord 44 - Single Leaf - Single Action																	
1	1	3	SK/AHP/ 240408/ T001	Single leaf	Strebord 44	2040	926	44	FULLY CAULKED					NIL	YES	33dB	This test is a calibration test and should result in a performance of Rw.33 - 34dB.
2	2	4	SK/AHP/ 240408/ T001	Single leaf	Strebord 44	2040	926	44	NORSOUND 710	NORSOUND 710	NORSOUND 710	NORSOUND 810	n/a	NIL	NO	32dB	
3	3	5	SK/AHP/ 240408/ T002	Single leaf	Strebord 44	2040	926	44	NORSOUND 710	NORSOUND 710	NORSOUND 710	NORSOUND 810	n/a	NIL	NO	31dB	NORSOUND 710 transferred from frame reveal to face of doorstop.
4	3A	8	SK/AHP/ 240408/ T003	2x Single Leaf doors fitted back to back in same frame.	2x Strebord 44	2040	926	44	NORSOUND 710	NORSOUND 710	NORSOUND 710	NORSOUND 810	n/a	NIL	NO	42dB	2No. Strebord 44mm Doors set back to back in same frame. Both leaves sealed NORSOUND 710 head & jambs and 810 to threshold.
Strebord 44 - Single Leaf - Single Action - Tested with Threshold Blocks.																	
5	35a	58	SK/AHP/ 240408/ T004	Single leaf	Strebord 44	2040	926	44	FULLY CAULKED					NIL	YES	34dB	Additional test for comparison with SRL Test 3. Blocks used at the bottom edge of door for comparison of threshold sealing.
6	37	61	SK/AHP/ 240408/ T004	Single leaf	Strebord 44	2040	926	44	NORSOUND 710	NORSOUND 710	NORSOUND 710	NORSOUND 815	n/a	NIL	NO	32dB	NORSOUND 815 fitted to closing face of Block 1
7	38	63	SK/AHP/ 240408/ T005	Single leaf	Strebord 44	2040	926	44	NORSOUND 710	NORSOUND 710	NORSOUND 710	NORSOUND 810 + 615	n/a	NIL	NO	32dB	NORSOUND 810 + NORSOUND 615 (fitted to closing face) with Block 2 . <i>Result indicates that the seals may not have been adjusted correctly.</i>
8	39	64	SK/AHP/ 240408/ T006	Single leaf	Strebord 44	2040	926	44	NORSOUND 710	NORSOUND 710	NORSOUND 710	NORSOUND 850 + 615	n/a	NIL	NO	32dB	850 housed in Block 3 used with 615 threshold
9	39a	62	SK/AHP/ 240408/ T007	Single leaf	Strebord 44	2040	926	44	NORSOUND 755	NORSOUND 755	NORSOUND 755	NORSOUND 815	n/a	NIL	NO	31dB	NORSOUND 755 'O' seal in aluminium carrier fitted to the frame doorstop at the head and jambs used with surface mounted NORSOUND 815 Drop Seal fitted Block 1 to closing face of the door. (<i>No seals within door leaf thickness</i>).
10	40	65	SK/AHP/ 240408/ T008	Single leaf	Strebord 44	2040	926	44	NORSOUND 710	NORSOUND 710	NORSOUND 710	NORSOUND 2x 720 + 615	n/a	NIL	NO	32dB	2x NORSOUND 720 'Trident' seals housed in BLOCK 4 used with 615 threshold
11	41	66	SK/AHP/ 240408/ T009	Single leaf	Strebord 44	2040	926	44	NORSOUND 710	NORSOUND 710	NORSOUND 710	NORSOUND 810 + 650	n/a	NIL	NO	33dB	NORSOUND 810 Drop Seal housed in BLOCK 5 used with 650 threshold
12	42	67	SK/AHP/ 240408/ T010	Single leaf	Strebord 44	2040	926	44	NORSOUND 710	NORSOUND 710	NORSOUND 710	NORSOUND 2x 720 + 650	n/a	NIL	NO	33dB	2x NORSOUND 720 (Trident) housed in BLOCK 6 used with 650 threshold
13	43	59	SK/AHP/ 240408/ T011	Single leaf	Strebord 44	2040	926	44	NORSOUND 710	NORSOUND 710	NORSOUND 710	NORSOUND 850 + 650	n/a	NIL	NO	33dB	NORSOUND 850 housed in BLOCK 7 used with 650 threshold
Strebord 44 - Single Leaf - Single Action - Tested with various glass types																	
14	2	4	SK/AHP/ 240408/ T001	Single leaf	Strebord 44	2040	926	44	NORSOUND 710	NORSOUND 710	NORSOUND 710	NORSOUND 810	n/a	NIL	NO	32dB	<i>Reference Test 44mm Strebord Flush door with NORSOUND 710 Seals to Head & Jambs & NORSOUND 810 Drop Seal to Threshold.</i>
15	70	53	SK/AHP/ 240408/ T012	Single leaf	Strebord 44	2040	926	44	NORSOUND 710	NORSOUND 710	NORSOUND 710	NORSOUND 810	n/a	6mm Pyroshield	NO	32dB	See SRL Test 3 above for fully caulked performance. Clear glass area = 1570 x 300mm (0.471M ²) = 25% of door leaf area.
16	71	54	SK/AHP/ 240408/ T013	Single leaf	Strebord 44	2040	926	44	NORSOUND 710	NORSOUND 710	NORSOUND 710	NORSOUND 810	n/a	7mm Pyrobelite	NO	33dB	See SRL Test 3 above for fully caulked performance. Clear glass area = 1570 x 300mm (0.471M ²) = 25% of door leaf area.
17	72a	45	SK/AHP/ 240408/ T014	Single leaf	Strebord 44	2040	926	44	NORSOUND 710	NORSOUND 710	NORSOUND 710	NORSOUND 810	n/a	12mm Pyrobelite	NO	34dB	See SRL Test 3 above for fully caulked performance. Clear glass area = 1570 x 300mm (0.471M ²) = 25% of door leaf area.
18	72b	46	SK/AHP/ 240408/ T015	Single leaf	Strebord 44	2040	926	44	NORSOUND 710	NORSOUND 710	NORSOUND 710	NORSOUND 810 + 650	n/a	12mm Pyrobelite	NO	34dB	See SRL Test 3 above for fully caulked performance. Clear glass area = 1570 x 300mm (0.471M ²) = 25% of door leaf area.

44 STREBORD Item No.	Norsound Test Ref.	SRL Test No.	Dwg. Ref	Door Configuration	Door Type	Height	Width	Tcks.	Head	Hanging Jamb	Closing Jamb	Threshold	Meeting Stiles	Glazing	Fully Caulked	Measured Performance Rw.	NOTES
19	72c	47	Sk/AHP/ 240408/ T015	Single leaf	Strebor44	2040	926	44	NORSOUND 710	NORSOUND 710	NORSOUND 710	NORSOUND 810 + 650	n/a	12mm Pyrobelite	NO	34dB	See SRL Test 3 above for fully caulked performance. Clear glass area = 1570 x 300mm (0.471M ²) = 25% of door leaf area. (Repeat test following glazing seal check)
20	74a	44	Sk/AHP/ 240408/ T016	Single leaf	Strebor44	2040	926	44	NORSOUND 710	NORSOUND 710	NORSOUND 710	NORSOUND 810	n/a	11.5 3Ply PA Res Glass	NO	34dB	See SRL Test 3 above for fully caulked performance. Clear glass area = 1570 x 300mm (0.471M ²) = 25% of door leaf area.
Strebor44 - Unequal Pair - Single Action																	
21	1	3	Sk/AHP/ 240408/ T001	Single leaf	Strebor44	2040	926	44	FULLY CAULKED SINGLE LEAF				NIL	YES	33dB	This test is a calibration test and should result in a performance of Rw.33 ~ 34dB.	
22	92	74	Sk/AHP/ 240408/ T017	Unequal Pair	Strebor44	2040	626 + 298	44	NORSOUND 710	NORSOUND 710	NORSOUND 710	NORSOUND 810 + 810	NORSOUND 720 + NORSOUND 510	NIL	NO	32dB	For Fully Caulked test on Strebor44 See SRL tests 3 & 58 above = 33-34dB
23	93	75	Sk/AHP/ 240408/ T018	Unequal Pair	Strebor44	2040	626 + 298	44	NORSOUND 710	NORSOUND 710	NORSOUND 710	NORSOUND 810 + 810	2x NORSOUND 755 + NORSOUND 720	NIL	NO	33dB	For Fully Caulked test on Strebor44 See SRL tests 3 & 58 above = 33-34dB
24	93a	76	Sk/AHP/ 240408/ T019	Unequal Pair	Strebor44	2040	626 + 298	44	NORSOUND 710	NORSOUND 710	NORSOUND 710	NORSOUND 810 + 810	2x NORSOUND 755	NIL	NO	32dB	As NORSOUND Test 93 (SRL Test 75) with NORSOUND 720 removed.
25	94	77	Sk/AHP/ 240408/ T020	Unequal Pair	Strebor44	2040	626 + 298	44	NORSOUND 710	NORSOUND 710	NORSOUND 710	NORSOUND 810 + 810	NORSOUND 855 + NORSOUND 855 carrier only + NORSOUND 720	NIL	NO	33dB	For Fully Caulked test on Strebor44 See SRL tests 3 & 58 above = 33-34dB
Strebor44 - Single Leaf - Double Action																	
26	102	110	Sk/AHP/ 240408/ T021	Single leaf Double Action	Strebor44	2019	915	44	FULLY CAULKED				NIL	YES	33dB	Single swing door = Rw.33dB - See SRL Test 3.	
27	103	111	Sk/AHP/ 240408/ T021	Single leaf Double Action	Strebor44	2019	915	44	2x NORSOUND 720	2x NORSOUND 720	2x NORSOUND 720	2x NORSOUND 855 used with NORSOUND 620 threshold.	n/a	NIL	NO	32dB	Double Action Door.
Strebor44+ - Single Leaf - Single Action																	
28	19	29	Sk/AHP/ 160208/ T022	Single leaf	Strebor44+	2040	926	54	FULLY CAULKED				NIL	YES	35dB	Door construction = 44mm Strebor44 with 2x5mm MDF Facings to make 54mm thickness door.	

Strebord 54 Doors

54 STREBORD Item No.	Norsound Test Ref.	SRL Test No.	Dwg. Ref	Door Configuration	Door Type	Height	Width	Tcks.	Head	Hanging Jamb	Closing Jamb	Threshold	Meeting Stiles	Glazing	Fully Caulked	Measured Performance Rw.	NOTES
Strebord 54 - Single Leaf - Single Action																	
1	5	9	Sk/AHP/ 240408/ T023	Single leaf	Strebord 54	2040	926	54	FULLY CAULKED					NIL	YES	35dB	This test is a calibration test and should result in a performance of Rw.36 +/-1dB.
2	6	10	Sk/AHP/ 240408/ T023	Single leaf	Strebord 54	2040	926	54	NORSOUND 720 + NORSOUND 710	NORSOUND 720 + NORSOUND 710	NORSOUND 720 + NORSOUND 710	NORSOUND 810	n/a	NIL	NO	32dB	
3	6a	11	Sk/AHP/ 240408/ T023	Single leaf	Strebord 54	2040	926	54	NORSOUND 720 + NORSOUND 710	NORSOUND 720 + NORSOUND 710	NORSOUND 720 + NORSOUND 710	NORSOUND 810	n/a	NIL	NO	33dB	Repeat of NORSOUND Test 6 (SRL test 10) following replacement of damaged 720 seal at the head and readjustment of doorstop.
4	7	12	Sk/AHP/ 240408/ T024	Single leaf	Strebord 54	2040	926	54	NORSOUND 720 + NORSOUND 710 + NORSOUND 755	NORSOUND 720 + NORSOUND 710 + NORSOUND 755	NORSOUND 720 + NORSOUND 710 + NORSOUND 755	NORSOUND 810 + NORSOUND 650A threshold	n/a	NIL	NO	34dB	
5	8	13	Sk/AHP/ 240408/ T025	Single leaf	Strebord 54	2040	926	54	NORSOUND 755	NORSOUND 755	NORSOUND 755	NORSOUND 650A threshold	n/a	NIL	NO	31dB	
Strebord 54 - Single Leaf - Single Action - Tested with Threshold Blocks.																	
6	10	15	Sk/AHP/ 240408/ T026	Single leaf	Strebord 54	2040	926	54	NORSOUND 720	NORSOUND 720	NORSOUND 720	NORSOUND 810	n/a	NIL	NO	32dB	NORSOUND 810 Drop seal to threshold housed in Block 8 . Refer to NORSOUND Test 5 (SRL Test 9) for fully caulked performance for 54mm Strebord .
7	11	16	Sk/AHP/ 240408/ T027	Single leaf	Strebord 54	2040	926	54	NORSOUND 710	NORSOUND 710	NORSOUND 710	NORSOUND 810	n/a	NIL	NO	32dB	NORSOUND 810 Drop seal to threshold housed in Block 8 . Refer to NORSOUND Test 5 (SRL Test 9) for fully caulked performance for 54mm Strebord .
8	11a	17	Sk/AHP/ 240408/ T027	Single leaf	Strebord 54	2040	926	54	NORSOUND 710	NORSOUND 710	NORSOUND 710	NORSOUND 810	n/a	NIL	NO	32dB	Repeat of NORSOUND Test 11 (SRL Test 16) following check and adjustment of seals.
9	12	18	Sk/AHP/ 240408/ T028	Single leaf	Strebord 54	2040	926	54	NORSOUND 710	NORSOUND 710	NORSOUND 710	NORSOUND 810 + NORSOUND 615 Threshold	n/a	NIL	NO	31dB	NORSOUND 810 Drop seal housed in Block 9 . NORSOUND 615 Threshold strip added. Refer to NORSOUND Test 5 (SRL Test 9) for fully caulked performance for 54mm Strebord .
10	13	19	Sk/AHP/ 240408/ T029	Single leaf	Strebord 54	2040	926	54	NORSOUND 710	NORSOUND 710	NORSOUND 710	NORSOUND 850 + NORSOUND 615 Threshold	n/a	NIL	NO	31dB	NORSOUND 850 Door Shoe housed in Block 10 . NORSOUND 615 Threshold strip added. Refer to NORSOUND Test 5 (SRL Test 9) for fully caulked performance for 54mm Strebord .
11	14	20	Sk/AHP/ 240408/ T030	Single leaf	Strebord 54	2040	926	54	NORSOUND 710	NORSOUND 710	NORSOUND 710	2 x NORSOUND 720 + NORSOUND 615 Threshold	n/a	NIL	NO	32dB	2No. NORSOUND 720 (Trident) seals housed in Block 11 . NORSOUND 615 Threshold strip added. Refer to NORSOUND Test 5 (SRL Test 9) for fully caulked performance for 54mm Strebord .
12	15	21	Sk/AHP/ 240408/ T031	Single leaf	Strebord 54	2040	926	54	NORSOUND 710	NORSOUND 710	NORSOUND 710	2 x NORSOUND 720 + NORSOUND 630 Threshold	n/a	NIL	NO	33dB	2No. NORSOUND 720 (Trident) seals housed in Block 11 . NORSOUND 630 Threshold strip added. Repeat of NORSOUND Test 14 (SRL Test 20). Test carried out at request of SRL to determine influence of larger aluminium strip.

54 STREBORD Item No.	Norsound Test Ref.	SRL Test No.	Dwg. Ref	Door Configuration	Door Type	Height	Width	Tcks.	Head	Hanging Jamb	Closing Jamb	Threshold	Meeting Stiles	Glazing	Fully Caulked	Measured Performance Rw.	NOTES
13	16	22	Sk/AHP/ 240408/ T032	Single leaf	Strebord 54	2040	926	54	NORSOUND 710	NORSOUND 710	NORSOUND 710	NORSOUND 810 + NORSOUND 650 threshold.	n/a	NIL	NO	33dB	NORSOUND 810 Drop seal housed in Block 12 . Used with NORSOUND 650 Threshold. Refer to NORSOUND Test 5 (SRL Test 9) for fully caulked performance for 54mm Strebord.
14	17	23	Sk/AHP/ 240408/ T033	Single leaf	Strebord 54	2040	926	54	NORSOUND 710	NORSOUND 710	NORSOUND 710	2 x NORSOUND720 + NORSOUND 650 threshold.	n/a	NIL	NO	33dB	2 No. NORSOUND 720 (Trident) seals housed in Block 13 . Used with NORSOUND 650 Threshold. Refer to NORSOUND Test 5 (SRL Test 9) for fully caulked performance for 54mm Strebord.
15	18	24	Sk/AHP/ 240408/ T034	Single leaf	Strebord 54	2040	926	54	NORSOUND 710	NORSOUND 710	NORSOUND 710	NORSOUND 850 + NORSOUND 650 threshold.	n/a	NIL	NO	33dB	NORSOUND 850 Door Shoe housed in Block 14 . Used with NORSOUND 650 Threshold. Refer to NORSOUND Test 5 (SRL Test 9) for fully caulked performance for 54mm Strebord.
Strebord 54 - Single Leaf - Single Action - Tested with various glass types																	
16	5	9	Sk/AHP/ 240408/ T023	Single leaf	Strebord 54	2040	926	54	FULLY CAULKED					NIL	YES	35dB	Un glazed fully caulked performance without glazing (See NORSOUND Test 5 (SRL Test 9).
17	60	30	Sk/AHP/ 240408/ T035	Single leaf	Strebord 54	2040	926	54	NORSOUND 710	NORSOUND 710	NORSOUND 710	NORSOUND 810	n/a	6mm Pyroshield	NO	34dB	See SRL Test 9 above for fully caulked performance. Clear glass area = 1570 x 300mm (0.471M ²) = 25% of door leaf area.
18	60a	31	Sk/AHP/ 240408/ T036	Single leaf	Strebord 54	2040	926	54	NORSOUND 710	NORSOUND 710	NORSOUND 710	NORSOUND 810 + NORSOUND 650A threshold	n/a	6mm Pyroshield	NO	34dB	See SRL Test 9 above for fully caulked performance. Clear glass area = 1570 x 300mm (0.471M ²) = 25% of door leaf area.
19	60b	32	Sk/AHP/ 240408/ T036	Single leaf	Strebord 54	2040	926	54	NORSOUND 710	NORSOUND 710	NORSOUND 710	NORSOUND 810 + NORSOUND 650A threshold	n/a	6mm Pyroshield	NO	35dB	Repeat of NORSOUND Test 60a (SRL Test 32) following seal and glazing mastic adjustment.
20	60c	42	Sk/AHP/ 240408/ T037	Single leaf	Strebord 54	2040	926	54	NORSOUND 710	NORSOUND 710	NORSOUND 710	NORSOUND 810	n/a	7mm Pyrobelite	NO	35dB	See SRL Test 9 above for fully caulked performance. Clear glass area = 1570 x 300mm (0.471M ²) = 25% of door leaf area.
21	61	41	Sk/AHP/ 240408/ T038	Single leaf	Strebord 54	2040	926	54	NORSOUND 710	NORSOUND 710	NORSOUND 710	NORSOUND 810	n/a	12mm Pyrobelite	NO	35dB	See SRL Test 9 above for fully caulked performance. Clear glass area = 1570 x 300mm (0.471M ²) = 25% of door leaf area.
22	63a	37	Sk/AHP/ 240408/ T039	Single leaf	Strebord 54	2040	926	54	NORSOUND 710	NORSOUND 710	NORSOUND 710	NORSOUND 810	n/a	16mm Pyrobel	NO	35dB	See SRL Test 9 above for fully caulked performance. Clear glass area = 1570 x 300mm (0.471M ²) = 25% of door leaf area.
Strebord 54 - Unequal Pair - Single Action																	
23	87a	91	Sk/AHP/ 240408/ T044	Unequal Pair	Strebord 54	2040	626 + 298	54	FULLY CAULKED					NIL	YES	34dB	Fully caulked test unequal pair. See NORSOUND Test 5 (SRL Test 9) for single leaf fully caulked performance. = Rw35dB .
24	80	86	Sk/AHP/ 240408/ T040	Unequal Pair	Strebord 54	2040	626 + 298	54	NORSOUND 710	NORSOUND 710	NORSOUND 710	NORSOUND 810 + 810	NORSOUND 720 + NORSOUND 510	NIL	NO	33dB	For Fully Caulked test on Strebord 54 unequal pair. See SRL test 91 above = 34dB
25	81	88	Sk/AHP/ 240408/ T041	Unequal Pair	Strebord 54	2040	626 + 298	54	NORSOUND 710	NORSOUND 710	NORSOUND 710	NORSOUND 810 + 810	2 x NORSOUND 755 + NORSOUND 720	NIL	NO	33dB	For Fully Caulked test on Strebord 54 unequal pair. See SRL test 91 above = 34dB
26	82	87	Sk/AHP/ 240408/ T042	Unequal Pair	Strebord 54	2040	626 + 298	54	NORSOUND 710	NORSOUND 710	NORSOUND 710	NORSOUND 810 + 810	NORSOUND 855 + NORSOUND 855 carrier only + NORSOUND 720	NIL	NO	33dB	For Fully Caulked test on Strebord 54 unequal pair. See SRL test 91 above = 34dB

54 STREBORD Item No.	Norsound Test Ref.	SRL Test No.	Dwg. Ref	Door Configuration	Door Type	Height	Width	Tcks.	Head	Hanging Jamb	Closing Jamb	Threshold	Meeting Stiles	Glazing	Fully Caulked	Measured Performance Rw.	NOTES
27	83	89	SK/AHP/ 240408/ T043	Unequal Pair	Strebord 54	2040	626 + 298	54	NORSOUND 710	NORSOUND 710	NORSOUND 710	NORSOUND 810 + 810	NORSOUND 710 + NORSOUND 720	NIL	NO	32dB	For Fully Caulked test on Strebord 54 unequal pair. See SRL test 91 above = 34dB
28	87	90	SK/AHP/ 240408/ T044	Unequal Pair	Strebord 54	2040	626 + 298	54	NORSOUND 710	NORSOUND 710	NORSOUND 710	NORSOUND 810 + 810	NORSOUND 710	NIL	NO	31dB	For Fully Caulked test on Strebord 54 unequal pair. See SRL test 91 above = 34dB
Strebord 54 - Single Leaf - Double Action																	
29	99	107	SK/AHP/ 240408/ T045	Single leaf Double Action	Strebord 54	2019	915	54	FULLY CAULKED					NIL	YES	33dB	See NORSOUND Test 5 (SRL Test 9) above for fully caulked single swing Strebord 54 door.
30	100	109	SK/AHP/ 240408/ T045	Single leaf Double Action	Strebord 54	2019	915	54	2x NORSOUND 720	2x NORSOUND 720	2x NORSOUND 720	2x NORSOUND 855 used with NORSOUND 620 threshold.	n/a	NIL	NO	32dB	Double Action Door.

Audiocore

Audiocore Item No.	Norsound Test Ref.	SRL Test No.	Dwg. Ref	Door Configuration	Door Type	Height	Width	Tcks.	Head	Hanging Jamb	Closing Jamb	Threshold	Meeting Stiles	Glazing	Fully Caulked	Measured Performance Rw.	NOTES
Audiocore - Single Leaf - Single Action - Tested with Threshold Blocks.																	
1	105	92	Sk/AHP/ 240408/ T073	Single leaf	AudioCore	2040	926	56	FULLY CAULKED					NIL	YES	42dB	Fully caulked test to establish potential maximum performance.
2	106	93	Sk/AHP/ 240408/ T073	Single leaf	AudioCore	2040	926	56	NORSOUND 710	NORSOUND 710	NORSOUND 710	NORSOUND 850	n/a	NIL	NO	36dB	Follow on test without seal adjustment.
3	106a	95	Sk/AHP/ 240408/ T073	Single leaf	AudioCore	2040	926	56	NORSOUND 710	NORSOUND 710	NORSOUND 710	NORSOUND 850	n/a	NIL	NO	36dB	Repeat test (without adjustment) following weekend settlement.
4	106b	96	Sk/AHP/ 240408/ T073	Single leaf	AudioCore	2040	926	56	NORSOUND 710	NORSOUND 710	NORSOUND 710	NORSOUND 850	n/a	NIL	NO	37dB	Repeat test following adjustment of seals.
5	107	97	Sk/AHP/ 240408/ T074	Single leaf	AudioCore	2040	926	56	NORSOUND 710	NORSOUND 710	NORSOUND 710	NORSOUND 850 + NORSOUND 650A threshold.	n/a	NIL	NO	41dB	
6	108	108	Sk/AHP/ 240408/ T075	Single leaf	AudioCore	2040	926	56	2x NORSOUND 710	2x NORSOUND 710	2x NORSOUND 710	NORSOUND 850 + NORSOUND 650A threshold.	n/a	NIL	NO	42dB	2 NORSOUND 710 in parallel to frame reveal
7	109	99	Sk/AHP/ 240408/ T076	Single leaf	AudioCore	2040	926	56	NORSOUND 710 + NORSOUND 755	NORSOUND 710 + NORSOUND 755	NORSOUND 710 + NORSOUND 755	NORSOUND 850 + NORSOUND 650A threshold.	n/a	NIL	NO	42dB	
8	110	100	Sk/AHP/ 240408/ T074	Single leaf	AudioCore	2040	926	56	NORSOUND 710	NORSOUND 710	NORSOUND 710	NORSOUND 850 + NORSOUND 650A threshold.	n/a	NIL	NO	41dB	Re Test to check NORSOUND Test 107 (SRL Test 97)
9	111	101	Sk/AHP/ 240408/ T077	Single leaf	AudioCore	2040	926	56	NORSOUND 710	NORSOUND 710	NORSOUND 710	NORSOUND 810	n/a	NIL	NO	38dB	
10	112	102	Sk/AHP/ 240408/ T077	Single leaf	AudioCore	2040	926	56	NORSOUND 710	NORSOUND 710	NORSOUND 710	NORSOUND 810 + AcuPads	n/a	NIL	NO	38dB	
11	113	103	Sk/AHP/ 240408/ T077	Single leaf	AudioCore	2040	926	56	FULLY CAULKED					NIL	YES	42dB	Repeat fully caulked test to confirm maximum potential performance

Flamebreak & Strebord 44mm	Norsound Test Ref.	SRL Test No.	Dwg. Ref	Door Configuration	Door Type	Height	Width	Tcks.	Head	Hanging Jamb	Closing Jamb	Threshold	Meeting Stiles	Glazing	Fully Caulked	Measured Performance Rw.	NOTES
Flamebreak 430 & Strebord 44- Single Leaf - Single Action																	
1	1	115	Sk/AHP/260608/ T001	Single leaf	Flamebreak 430	2040	926	44	FULLY CAULKED					Reference panel	YES	32dB	Fully caulked test to establish potential maximum performance. Door fitted with flush panel to Flamebreak 430 construction to establish reference performance.
2	2	116	Sk/AHP/260608/ T001	Single leaf	Flamebreak 430	2040	926	44	NORSOUND 710	NORSOUND 710	NORSOUND 710	NORSOUND 810	n/a	Reference panel	NO	31dB	Door fitted with flush panel to Flamebreak 430 construction to establish reference performance.
3	3	117	Sk/AHP/260608/ T002	Single leaf	Flamebreak 430	2040	926	44	NORSOUND 710	NORSOUND 710	NORSOUND 710	NORSOUND 810	n/a	6mm Pyroshield	NO	32dB	Solid panel replaced with Glazing Panel 1 = 6mm Pyroshield.
4	4	118	Sk/AHP/260608/ T003	Single leaf	Flamebreak 430	2040	926	44	NORSOUND 710	NORSOUND 710	NORSOUND 710	NORSOUND 810	n/a	10mm Pyrodur.	NO	32dB	Glazing Panel 1 replaced with Glazing panel 2 = 10mm Pyrodur.
5	5	119	Sk/AHP/260608/ T004	Single leaf	Flamebreak 430	2040	926	44	NORSOUND 710	NORSOUND 710	NORSOUND 710	NORSOUND 810	n/a	15mm Pyrostop.	NO	32dB	Glazing Panel 2 replaced with Glazing panel 3 = 15mm Pyrostop.
6	6	120	Sk/AHP/260608/ T005	Single leaf	Flamebreak 430	2040	926	44	NORSOUND 710	NORSOUND 710	NORSOUND 710	NORSOUND 810	n/a	16.8mm Optilam-Phon.	NO	32dB	Glazing Panel 3 replaced with Glazing panel 4 = 16.8mm Optilam Phon.
7	7	121	Sk/AHP/260608/ T006	Single leaf	Strebord 44	2040	926	44	FULLY CAULKED					Reference panel	YES	35dB	Fully caulked test to establish potential maximum performance. Door fitted with flush panel to Strebord 44 construction to establish reference performance.
8	8	124	Sk/AHP/260608/ T006	Single leaf	Strebord 44	2040	926	44	NORSOUND 710	NORSOUND 710	NORSOUND 710	NORSOUND 810	n/a	Reference panel	NO	33dB	NOTE: SRL Test 123 carried out without adjustment of seals at threshold. Rw.32dB result. Seals reset with configuration retested as SRL Test 124. Door fitted with flush panel to Strebord 44 construction to establish reference performance.
9	9	125	Sk/AHP/260608/ T007	Single leaf	Strebord 44	2040	926	44	NORSOUND 710	NORSOUND 710	NORSOUND 710	NORSOUND 810	n/a	6mm Pyroshield	NO	33dB	Solid panel replaced with Glazing Panel 1 = 6mm Pyroshield.
10	10	126	Sk/AHP/260608/ T008	Single leaf	Strebord 44	2040	926	44	NORSOUND 710	NORSOUND 710	NORSOUND 710	NORSOUND 810	n/a	10mm Pyrodur.	NO	33dB	Glazing Panel 1 replaced with Glazing panel 2 = 10mm Pyrodur.
11	10a	127	Sk/AHP/260608/ T008a	Single leaf	Strebord 44	2040	926	44	NORSOUND 710	NORSOUND 710	NORSOUND 710	NORSOUND 810 + NORSOUND 650A	n/a	10mm Pyrodur.	NO	34dB	Glazing Panel 1 replaced with Glazing panel 2 = 10mm Pyrodur.
12	11	128	Sk/AHP/260608/ T009	Single leaf	Strebord 44	2040	926	44	NORSOUND 710	NORSOUND 710	NORSOUND 710	NORSOUND 810 + NORSOUND 650A	n/a	15mm Pyrostop.	NO	35dB	Glazing Panel 2 replaced with Glazing panel 3 = 15mm Pyrostop.
13	12	129	Sk/AHP/260608/ T0010	Single leaf	Strebord 44	2040	926	44	NORSOUND 710	NORSOUND 710	NORSOUND 710	NORSOUND 810 + NORSOUND 650A	n/a	16.8mm Optilam-Phon.	NO	35dB	Glazing Panel 3 replaced with Glazing panel 4 = 16.8mm Optilam Phon.
14	13	130	Sk/AHP/260608/ T0011	Single leaf	Flamebreak 430	2040	926	44	FULLY CAULKED					6mm Pyroshield	YES	33dB	Fully caulked test to establish potential maximum performance with 50% glazing with 6mm Pyroshield glass.
15	14	131	Sk/AHP/260608/ T011	Single leaf	Flamebreak 430	2040	926	44	NORSOUND 710	NORSOUND 710	NORSOUND 710	NORSOUND 810	n/a	6mm Pyroshield	NO	32dB	Operational door with 50% glazing using 6mm Pyroshield glass. For comparison with NORSOUND Test 3.

Flamebreak 660

Flamebreak 54mm	Norsound Test Ref.	SRL Test No.	Dwg. Ref	Door Configuration	Door Type	Height	Width	Tcks.	Head	Hanging Jamb	Closing Jamb	Threshold	Meeting Stiles	Glazing	Fully Caulked	Measured Performance Rw.	NOTES
Flamebreak 660 - Single Leaf - Single Action																	
16	24	132	Sk/AHP/260608/ T011a	Single leaf	Flamebreak 660	2040	926	54	FULLY CAULKED					Reference panel	YES	35dB	Fully caulked test to establish potential maximum performance. Door fitted with flush panel to Flamebreak 660 construction to establish reference performance. Closing force = 65N Opening Force = 40N. 800mm from pivot centre
17	25	139	Sk/AHP/260608/ T011a	Single leaf	Flamebreak 660	2040	926	54	NORSOUND 710	NORSOUND 710	NORSOUND 710	NORSOUND 810 + NORSOUND 650A	n/a	Reference panel	NO	34dB	Door fitted with flush panel to Flamebreak 430 construction to establish reference performance.
18	26	140	Sk/AHP/260608/ T011b	Single leaf	Flamebreak 660	2040	926	54	NORSOUND 710	NORSOUND 710	NORSOUND 710	NORSOUND 810 + NORSOUND 650A	n/a	6mm Pyroshield	NO	34dB	Solid panel replaced with Glazing Panel 1 = 6mm Pyroshield.
19	27	141	Sk/AHP/260608/ T011c	Single leaf	Flamebreak 660	2040	926	54	NORSOUND 710	NORSOUND 710	NORSOUND 710	NORSOUND 810 + NORSOUND 650A	n/a	10mm Pyrodur.	NO	35dB	Glazing Panel 1 replaced with Glazing panel 2 = 10mm Pyrodur.
20	28	142	Sk/AHP/260608/ T011d	Single leaf	Flamebreak 660	2040	926	54	NORSOUND 710	NORSOUND 710	NORSOUND 710	NORSOUND 810 + NORSOUND 650A	n/a	15mm Pyrostop.	NO	35dB	Glazing Panel 2 replaced with Glazing panel 3 = 15mm Pyrostop.
21	29	137	Sk/AHP/260608/ T011e	Single leaf	Flamebreak 660	2040	926	54	NORSOUND 710	NORSOUND 710	NORSOUND 710	NORSOUND 810	n/a	16.8mm Optilam-Ph on.	NO	34dB	Glazing Panel 3 replaced with Glazing panel 4 = 16.8mm Optilam Phon.
22	29b	138	Sk/AHP/260608/ T011f	Single leaf	Flamebreak 660	2040	926	54	NORSOUND 710	NORSOUND 710	NORSOUND 710	NORSOUND 810 + NORSOUND 650A	n/a	16.8mm Optilam-Ph on.	NO	35dB	Glazing Panel 3 replaced with Glazing panel 4 = 16.8mm Optilam Phon. Modified NORSOUND 650 with seal added to improve sealing at threshold.
23	26a	133	Sk/AHP/260608/ T011b	Single leaf	Flamebreak 660	2040	926	54	FULLY CAULKED					6mm Pyroshield	NO	35dB	Solid panel replaced with Glazing Panel 1 = 6mm Pyroshield.
24	27a	134	Sk/AHP/260608/ T011c	Single leaf	Flamebreak 660	2040	926	54	FULLY CAULKED					10mm Pyrodur.	NO	36dB	Glazing Panel 1 replaced with Glazing panel 2 = 10mm Pyrodur.
25	28a	135	Sk/AHP/260608/ T011d	Single leaf	Flamebreak 660	2040	926	54	FULLY CAULKED					15mm Pyrostop.	NO	36dB	Glazing Panel 2 replaced with Glazing panel 3 = 15mm Pyrostop.
26	29a	136	Sk/AHP/260608/ T011f	Single leaf	Flamebreak 660	2040	926	54	FULLY CAULKED					16.8mm Optilam-Ph on.	NO	36dB	Glazing Panel 3 replaced with Glazing panel 4 = 16.8mm Optilam Phon.
27	30	143	Sk/AHP/260608/ T012	Single leaf	Flamebreak 660 with letter plate 12in. Gold	2040	926	54	NORSOUND 710	NORSOUND 710	NORSOUND 710	NORSOUND 810 + NORSOUND 650A	n/a	Reference panel with letter plate.	NO	33dB	Test setup all as NORSOUND Test 25 but with letter plate added to Reference panel. 12in. Gold / gold letter plate added to reference panel and tested for comparison with Test 25.
28	31	144	Sk/AHP/260608/ T013	Single leaf	Flamebreak 660 with letter plate P209G	2040	926	54	NORSOUND 710	NORSOUND 710	NORSOUND 710	NORSOUND 810 + NORSOUND 650A	n/a	Reference panel with letter plate.	NO	32dB	Test setup all as NORSOUND Test 25 but with letter plate added to Reference panel. P209G letter plate fitted to reference panel for comparison with Test 25.

Flamebreak 54mm	Norsound Test Ref.	SRL Test No.	Dwg. Ref	Door Configuration	Door Type	Height	Width	Tcks.	Head	Hanging Jamb	Closing Jamb	Threshold	Meeting Stiles	Glazing	Fully Caulked	Measured Performance Rw.	NOTES
29	31a	145	Sk/AHP/ 260608/ T013	Single leaf	Flamebreak 660 with letter plate P209G	2040	926	54	NORSOUND 710	NORSOUND 710	NORSOUND 710	NORSOUND 810 + NORSOUND 650A	n/a	Reference panel with letter plate.	NO	33dB	Test setup all as NORSOUND Test 25 but with letter plate added to Reference panel. P209G letter plate fitted to reference panel for comparison with Test 25. Reversed plate brush to receiving room. Added small strip if E seal to flap to receiving room side.
30	32	146	Sk/AHP/ 260608/ T014	Single leaf	Flamebreak 660 with GRI -250x250 fire grille	2040	926	54	NORSOUND 710	NORSOUND 710	NORSOUND 710	NORSOUND 810 + NORSOUND 650A	n/a	16.8mm Optilam-Ph on.	NO	17dB	Test setup all as NORSOUND Test 29b but with aperture cut in door and fitted with a ventilation grille. Door fitted with GRI 250x250 fire grille with cover grilles fitted to both faces. Door fitted with Optilam- Phon glass for comparison with Test 29b.

Appendix 5 - Drawings

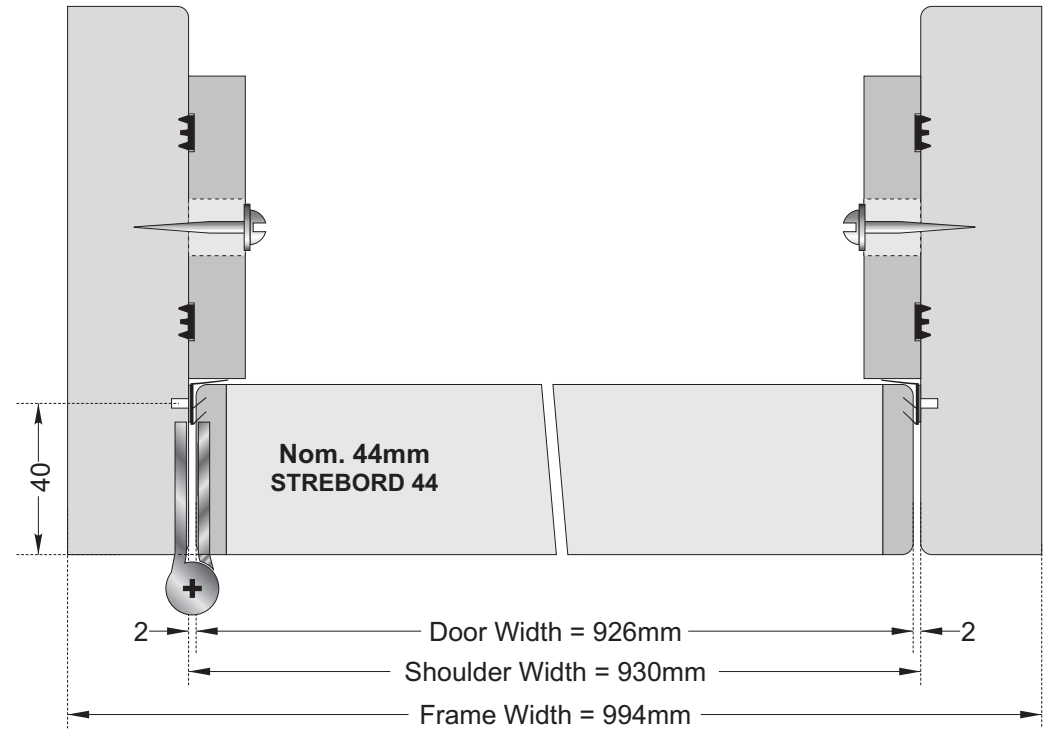
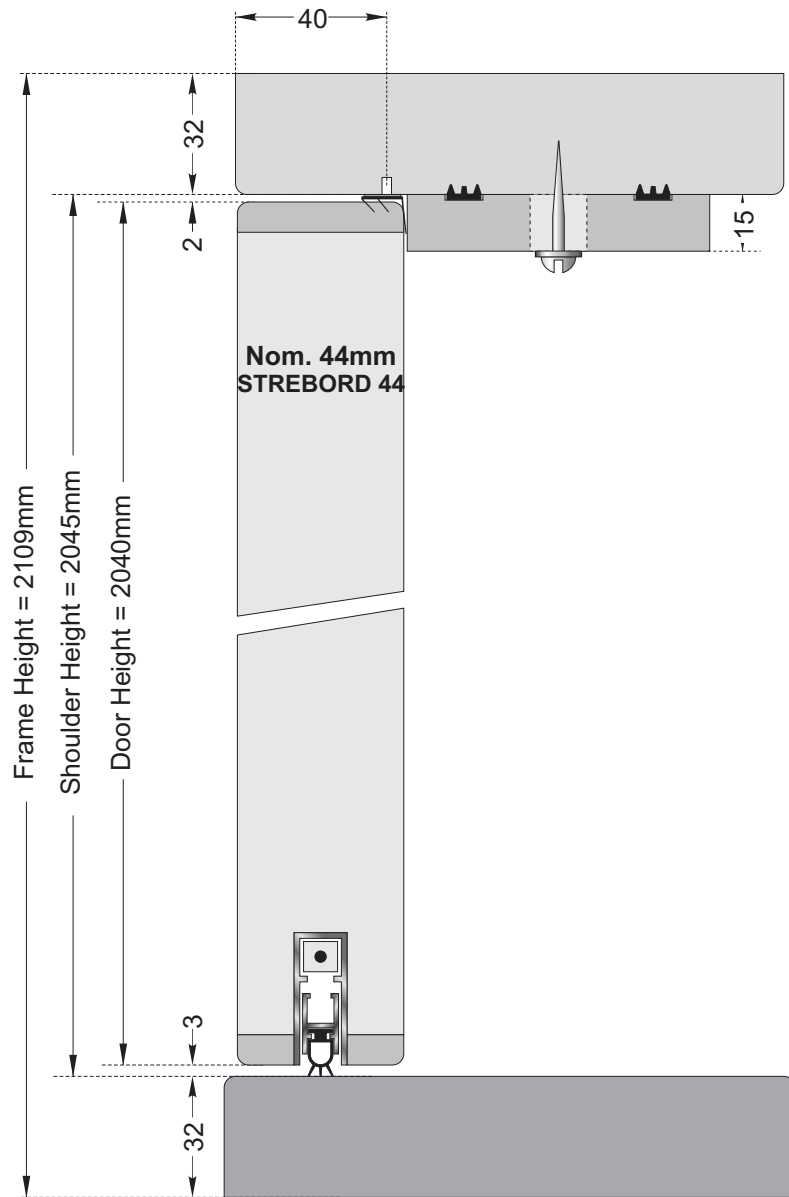

TEST 1: Fully caulked to establish maximum potential performance for the doorset. = **Rw.33dB SRL Test 3.**

TEST 2: NORSOUND 710 to Head & Jambs. NORSOUND 810 to Threshold. = **Rw.32dB SRL Test 4.**

Dwg. Ref:	Sk/AHP/160208/T001		
TITLE	NORSOUND Acoustic Tests Reference Tests 1 & 2 STREBORD 44		
Scale	1 : 2	Date	16/6/08
Revisions			

Tony Palmer
Invented 2000

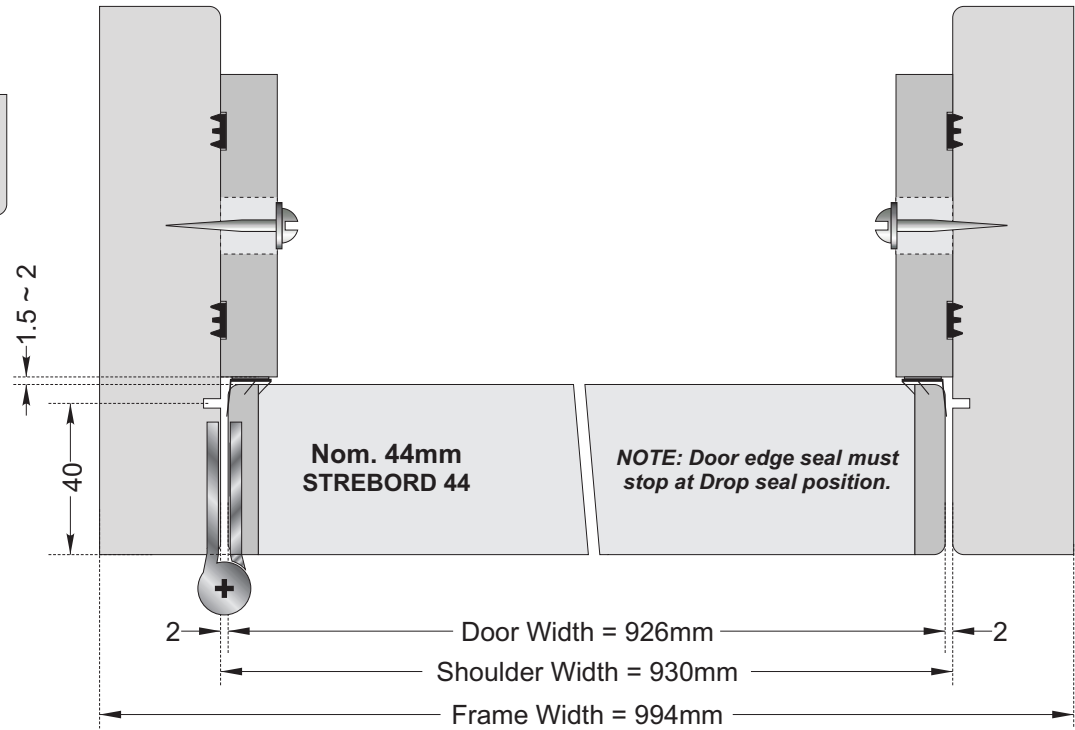
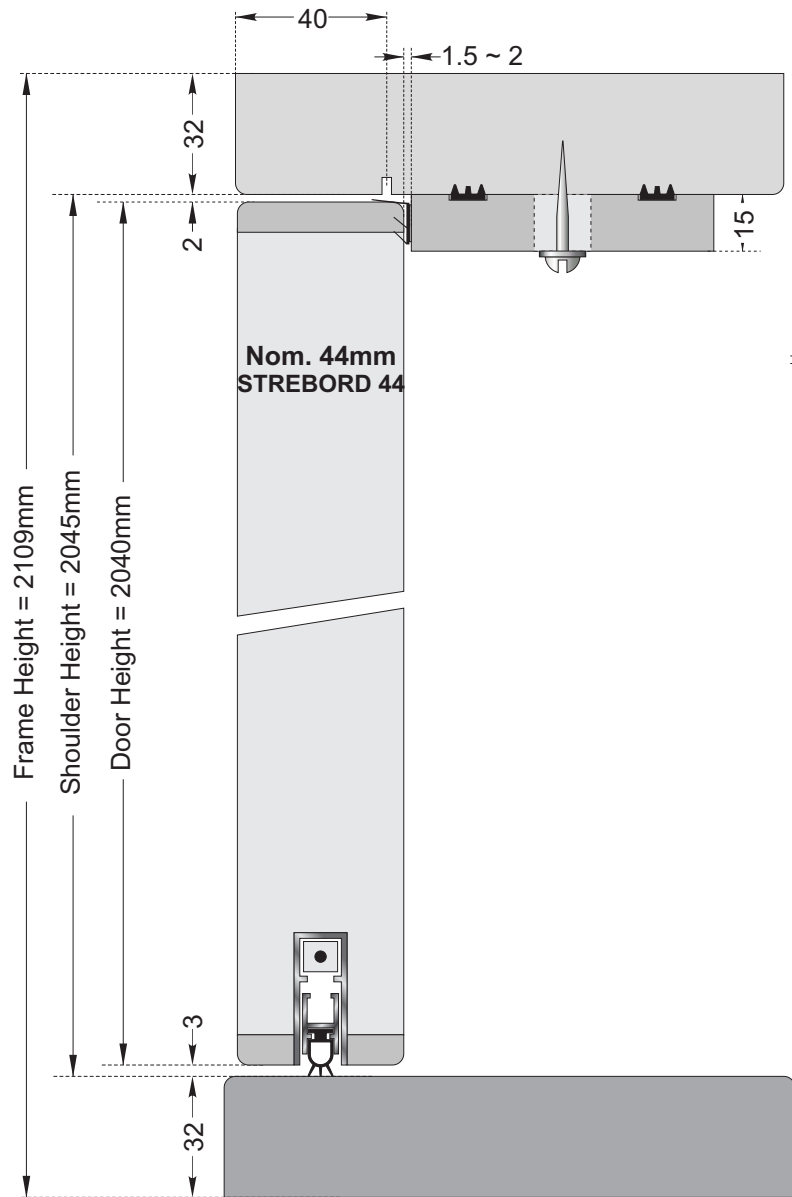

TEST 3: As Reference Test 2 but with NORSOUND 710 transferred from frame reveal to face of doorstep. = **Rw.31dB SRL Test 5.**

Dwg. Ref:	Sk/AHP/160208/T002		
TITLE	NORSOUND Acoustic Tests Reference Test 3 STREBORD 44		
Scale	1 : 2	Date	16/6/08
Revisions			

Tony Palmer
Invented 2000

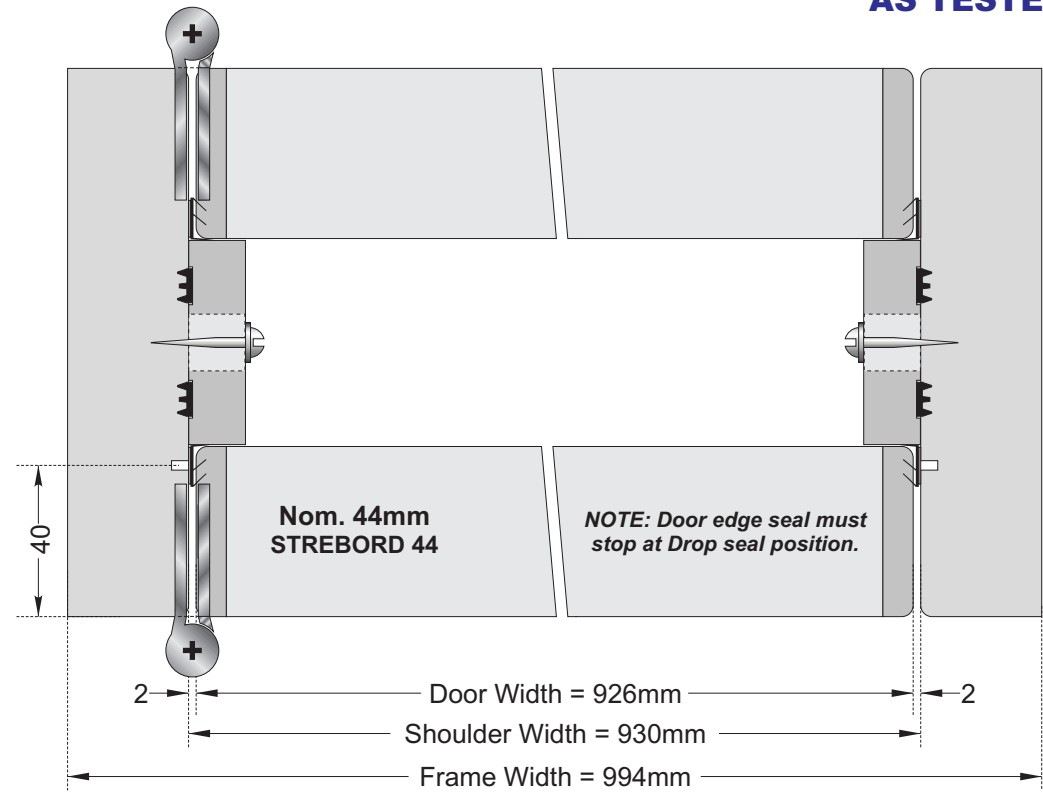
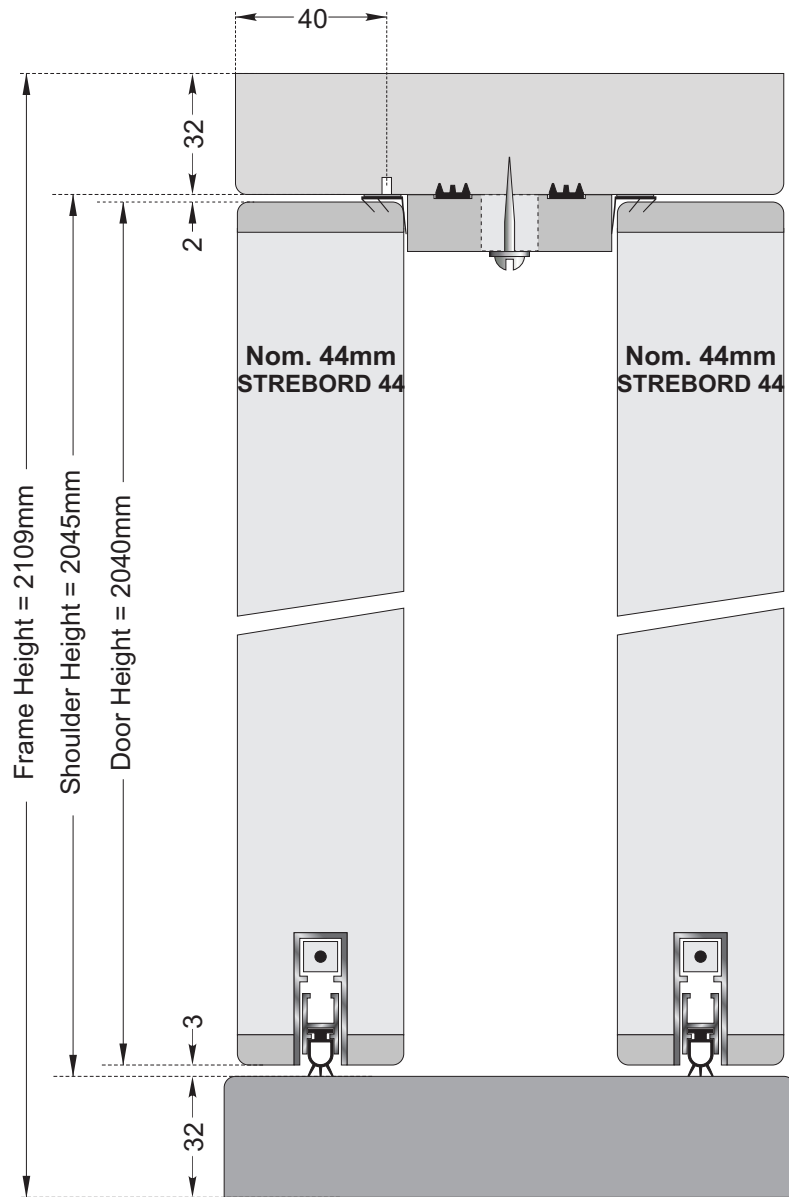

TEST 3A: Hang 2nd. STREBORD 44 door and replace door stop to create double door arrangement with 2nd. door sealed with NORSOUND 710 to Head & Jambs and NORSOUND 810 to Threshold. = **Rw.42dB SRL Test 8.**

Dwg. Ref:	Sk/AHP/240408/T003		
TITLE	NORSOUND Acoustic Tests Reference Tests 3A STREBORD 44		
Scale	1 : 2	Date	16/6/08
Revisions			

Tony Palmer
Invented 2000

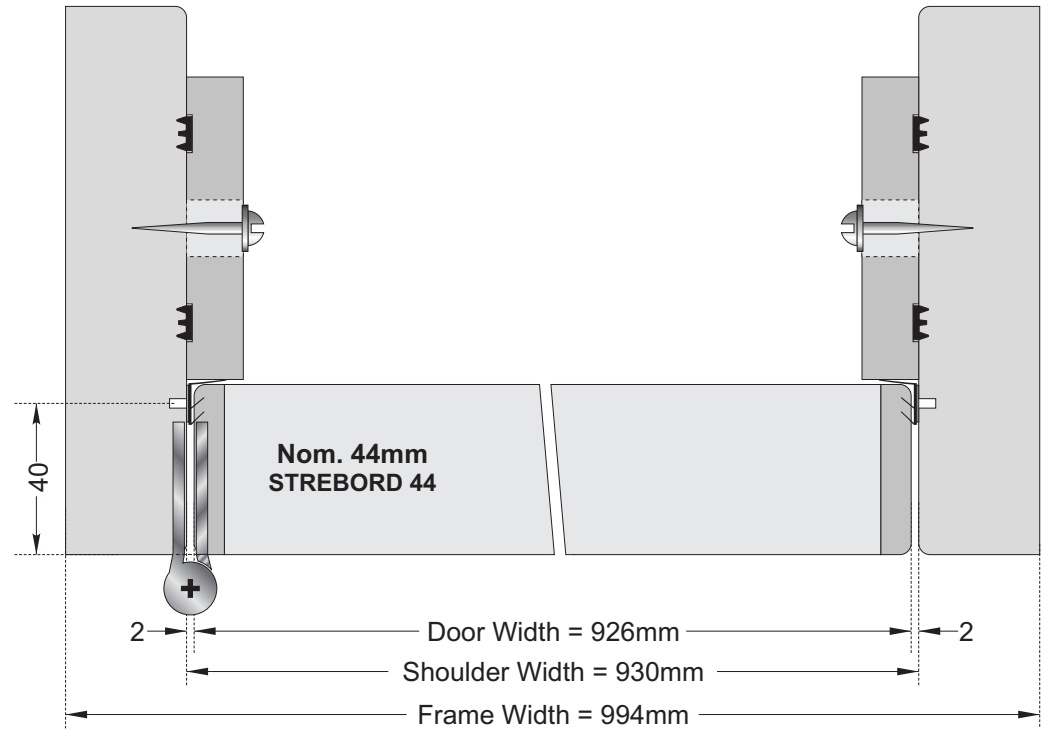
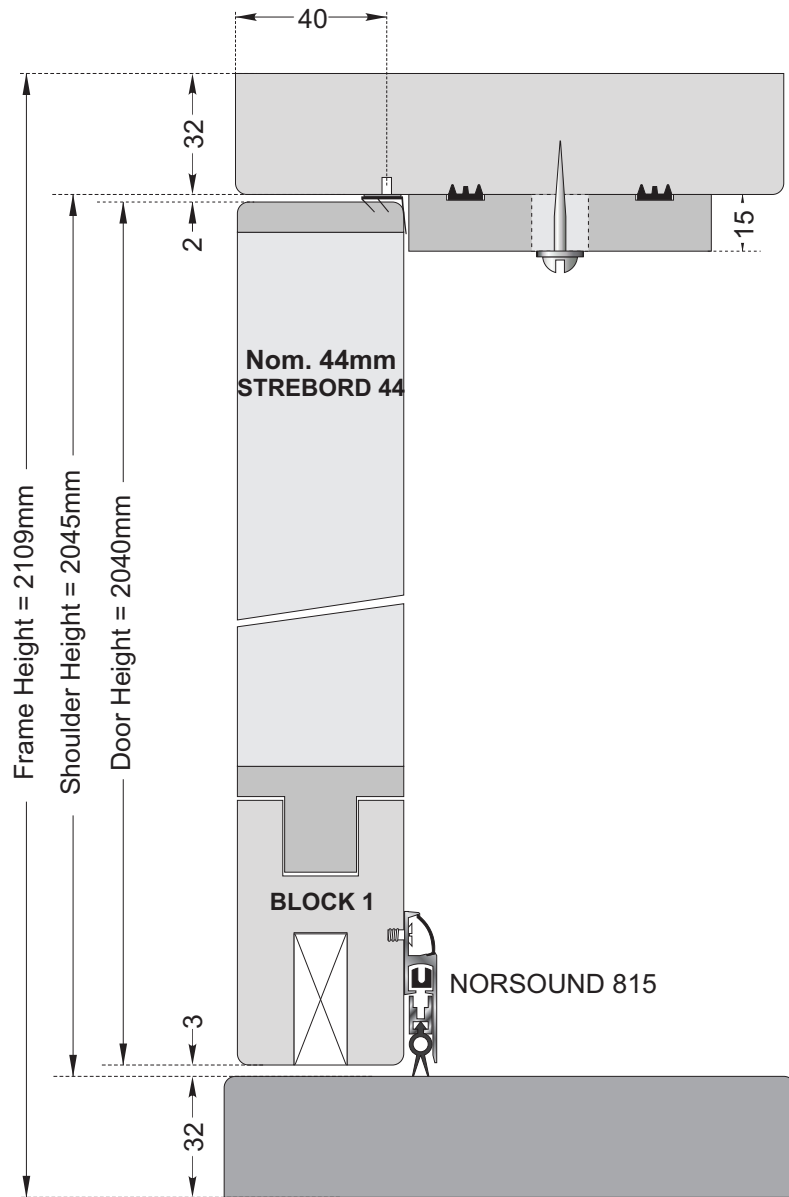

TEST 35A: Fully Caulked Strebord 44 th Block 1. = **Rw.34dB SRL Test 58**

TEST 37: NORSOUND 710 to Head & Jambs - NORSOUND 815 Surface mounted Drop Seal to Threshold. = **Rw.32dB SRL Test 61**

Dwg. Ref:	Sk/AHP/160208/T004		
TITLE	NORSOUND Acoustic Tests Tests 35A & 37 STREBORD 44		
Scale	1 : 2	Date	16/6/08
Revisions			

Tony Palmer *Specialist 2000*

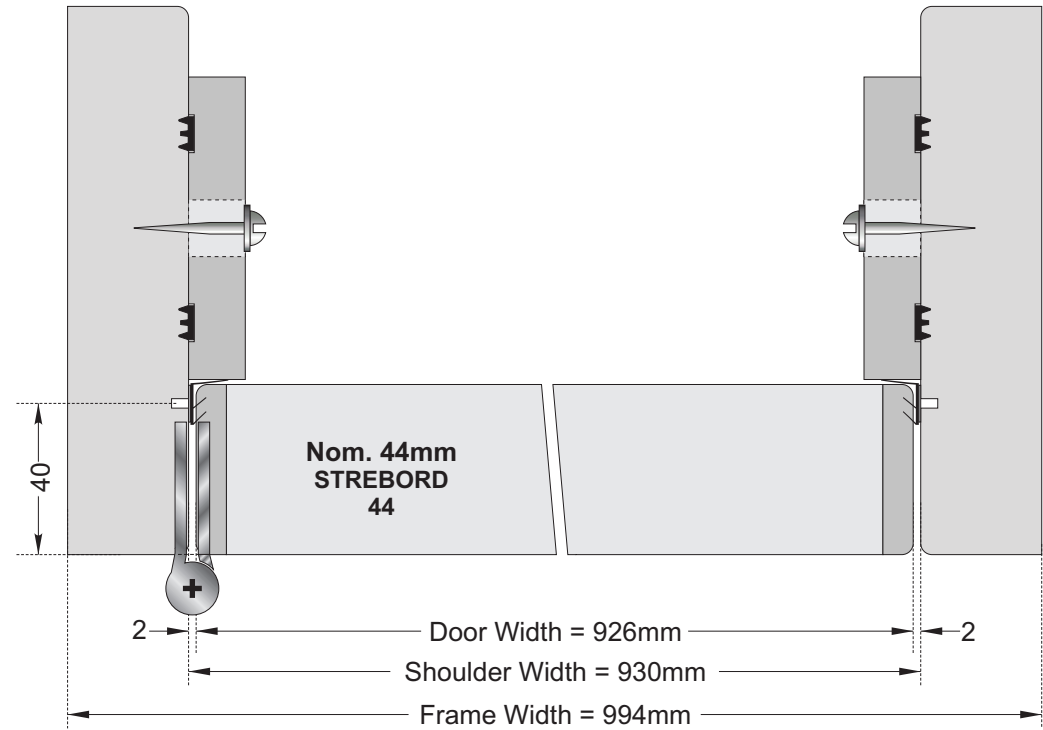
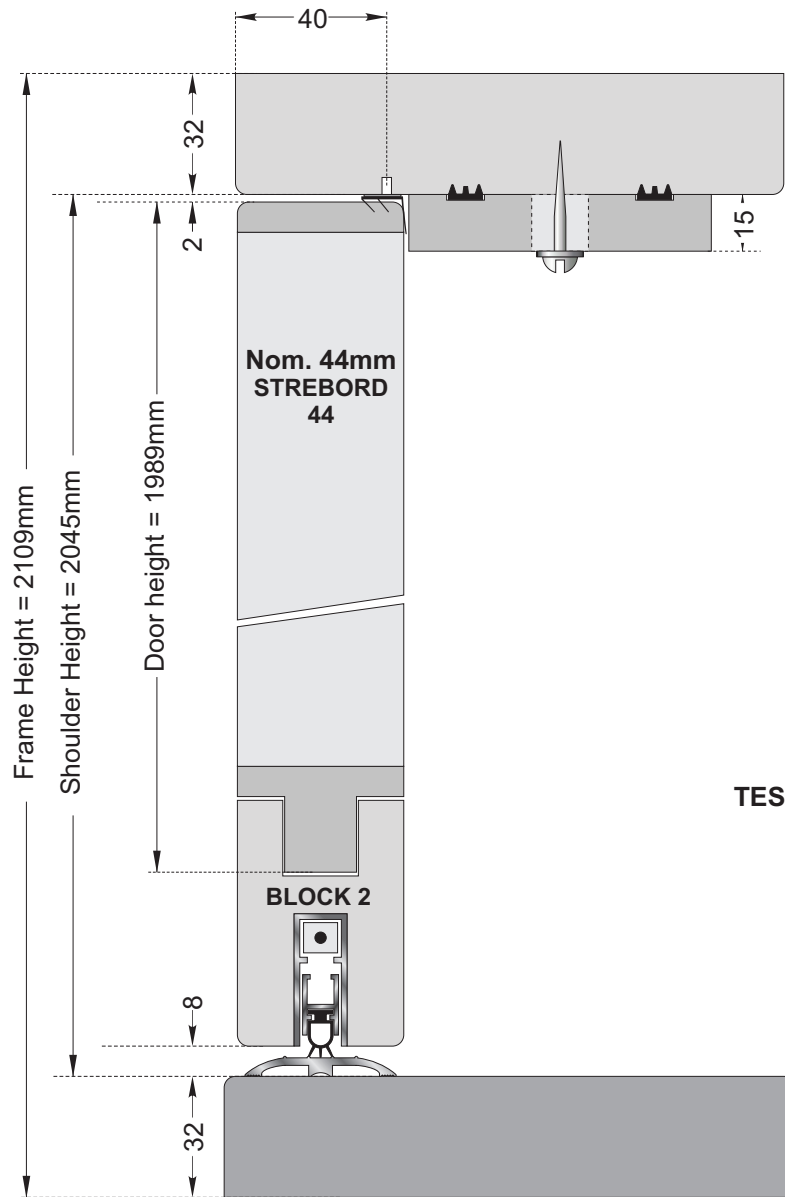

TEST 38: BLOCK 2 with NORSOUND 810 Drop Seal used with NORSOUND 615 Threshold Strip.
 = **Rw.32dB SRL Test 63.**

Dwg. Ref:	Sk/AHP/160208/T005		
TITLE	NORSOUND Acoustic Tests Test 38 STREBORD 44		
Scale	1 : 2	Date	16/6/08
Revisions			

Tony Palmer *Smartech 2000*

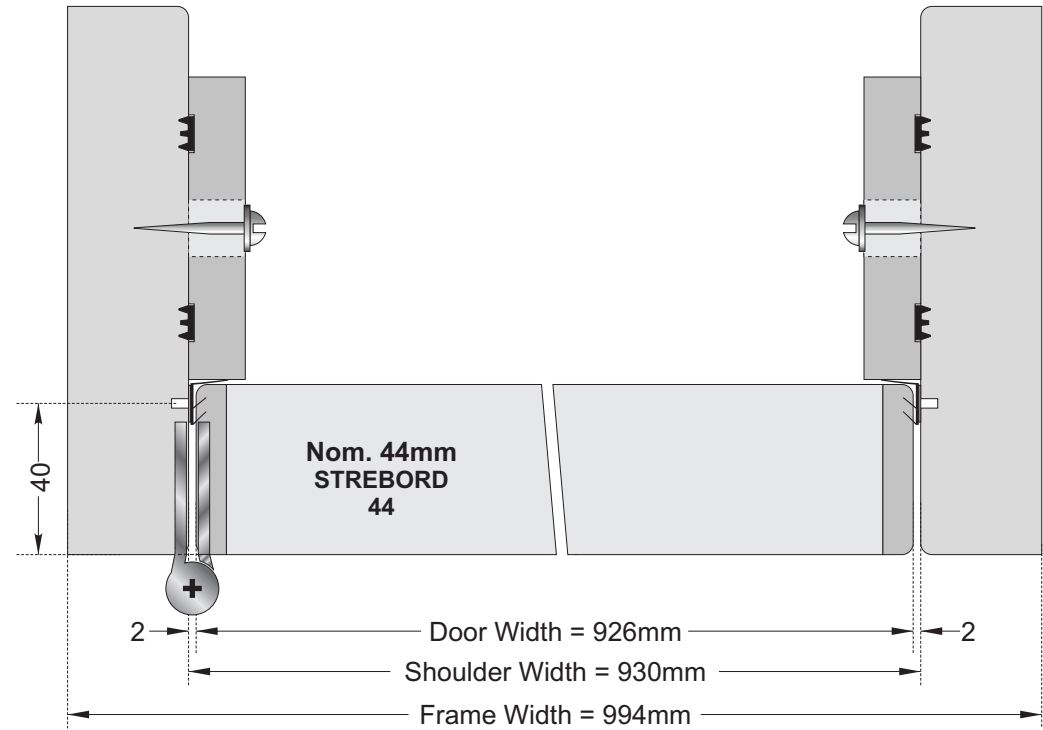
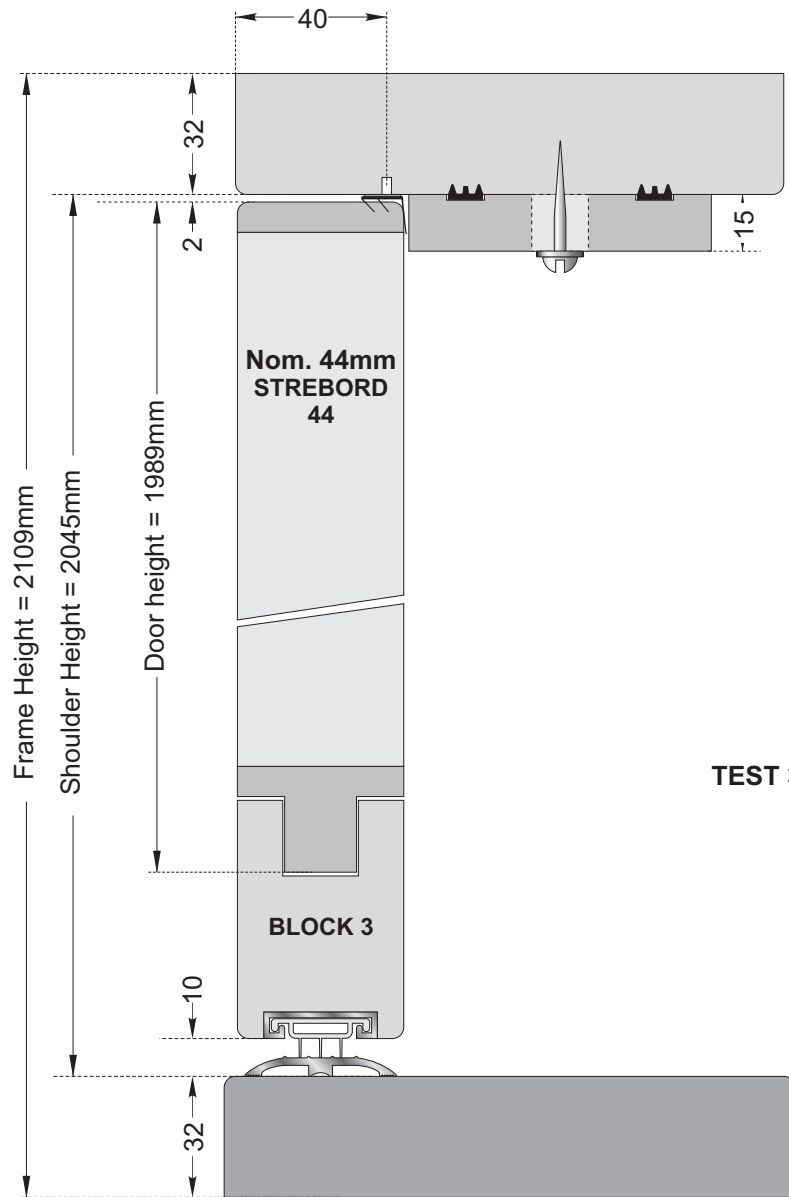

TEST 39: BLOCK 3 with NORSOUND 850 Door Shoe used with NORSOUND 615 Threshold Strip.
 = **Rw.32dB. SRL Test 64.**

Dwg. Ref:	Sk/AHP/160208/T006		
TITLE	NORSOUND Acoustic Tests Test 39 STREBORD 44		
Scale	1 : 2	Date	16/6/08
Revisions			

Tony Palmer *Smartech 2000*

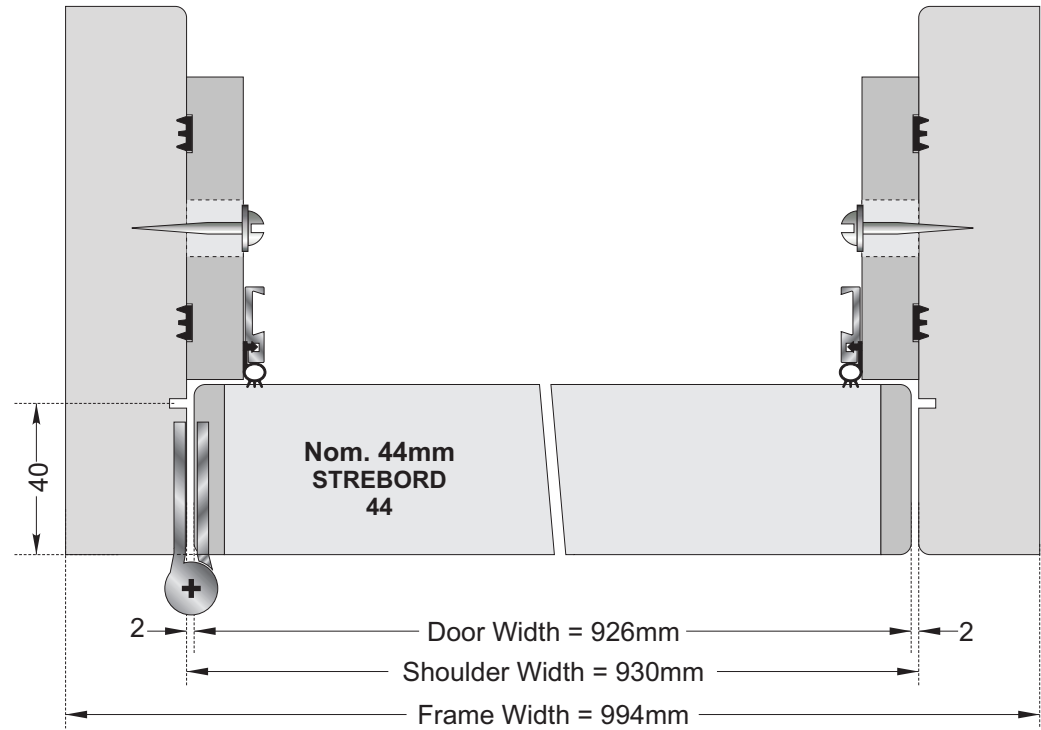
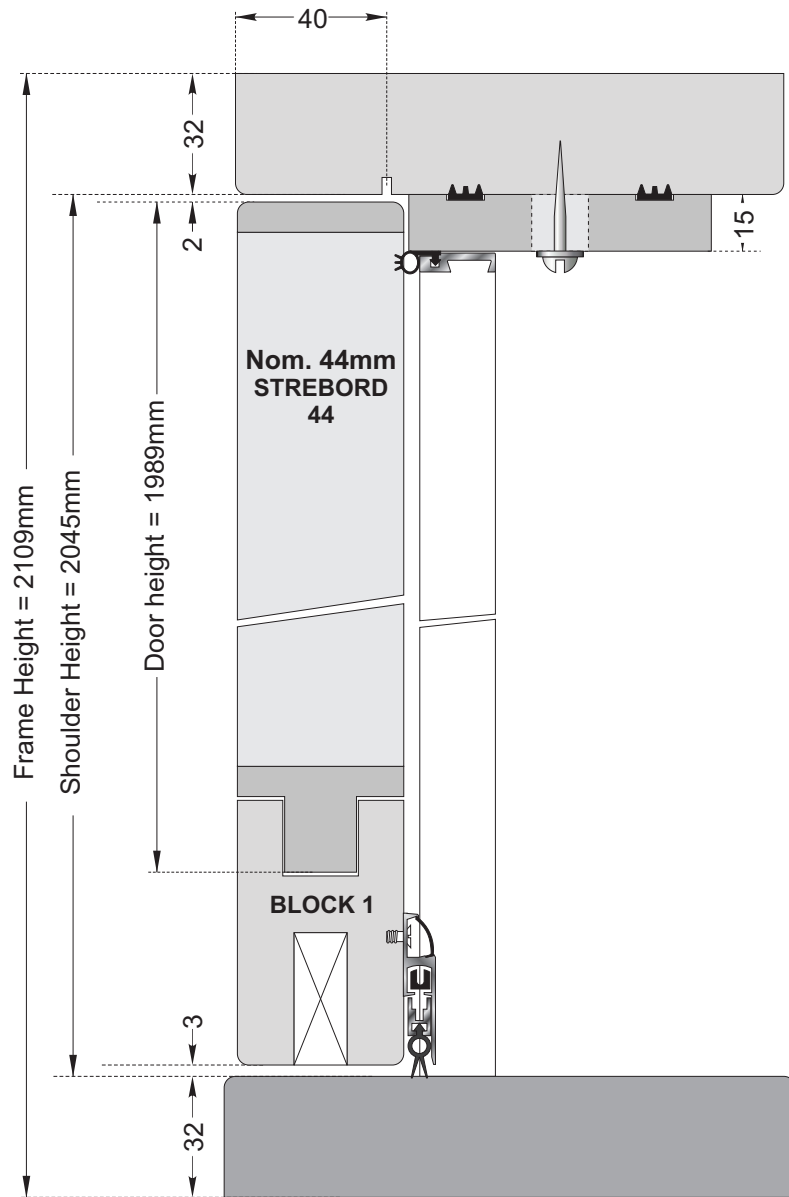

TEST 39a: BLOCK 1 wit face fixed NORSOUND 815 Drop Seal to Threshold.
 NORSOUND 755 Seal to Head & Jamb. = **Rw.31dB SRL Test 62**

Dwg. Ref:	Sk/AHP/160208/T007		
TITLE	NORSOUND Acoustic Tests Test 39a STREBORD 44		
Scale	1 : 2	Date	16/6/08
Revisions			

Tony Palmer *Smartech 2000*

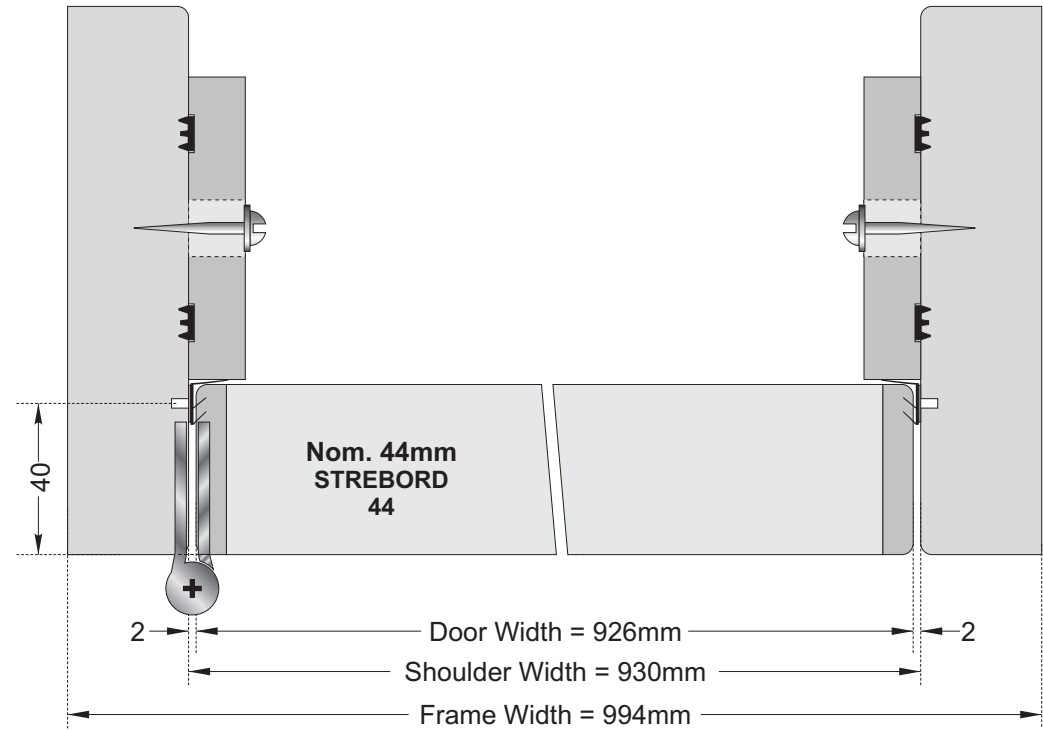
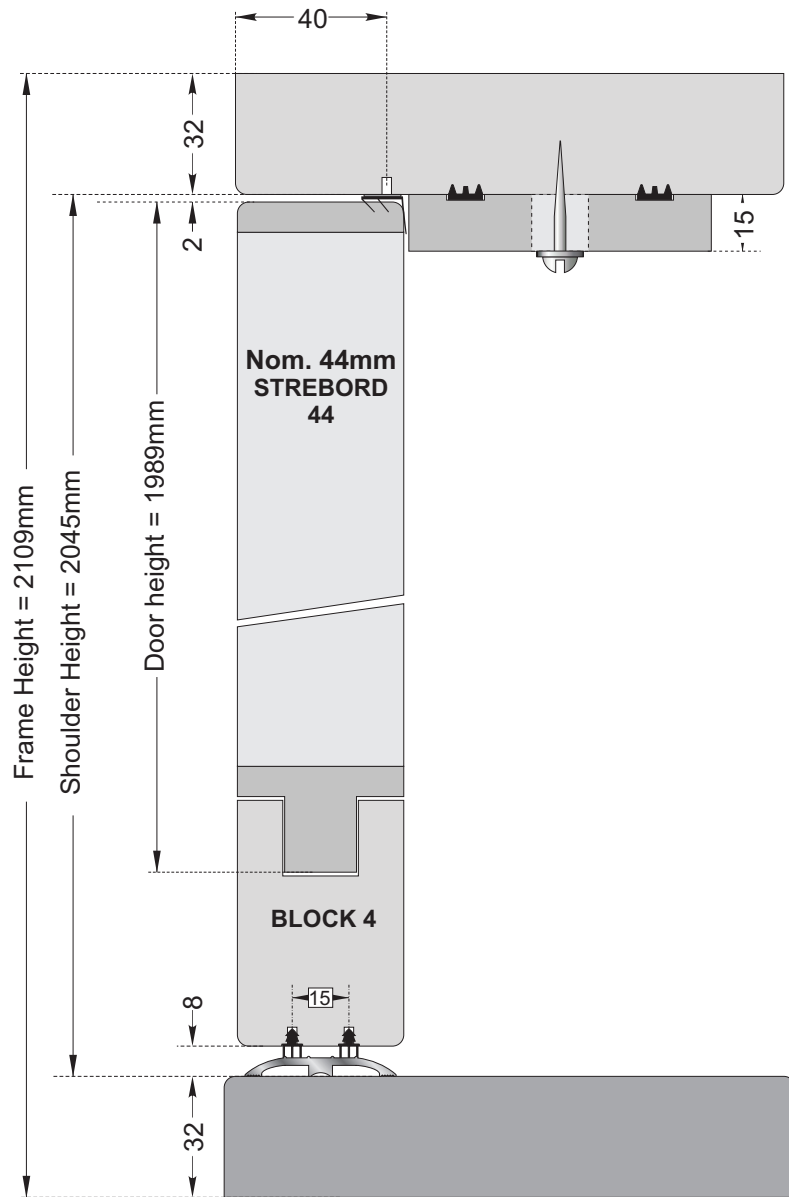

TEST 40: BLOCK 4 with Twin 720 Trident seals used with NORSOUND 615 Threshold Strip.
= **Rw.32dB. SRL Test 65.**

Dwg. Ref:	Sk/AHP/160208/T008		
TITLE	NORSOUND Acoustic Tests Test 40 STREBORD 44		
Scale	1 : 2	Date	16/6/08
Revisions			

Tony Palmer *Smartech 2000*

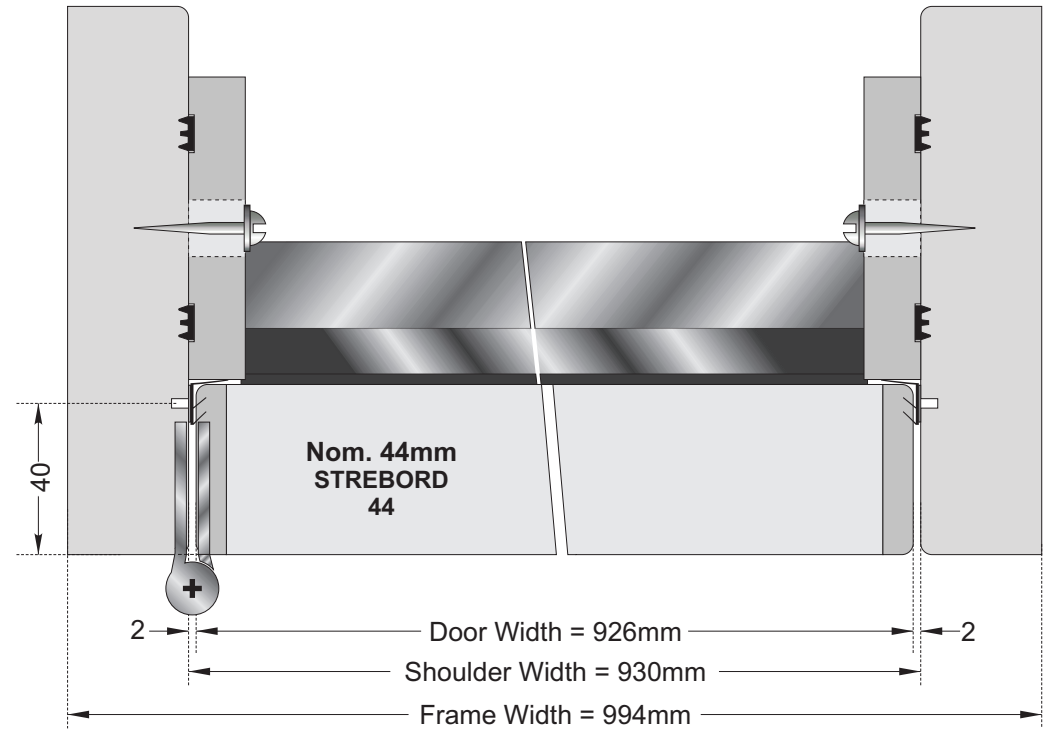
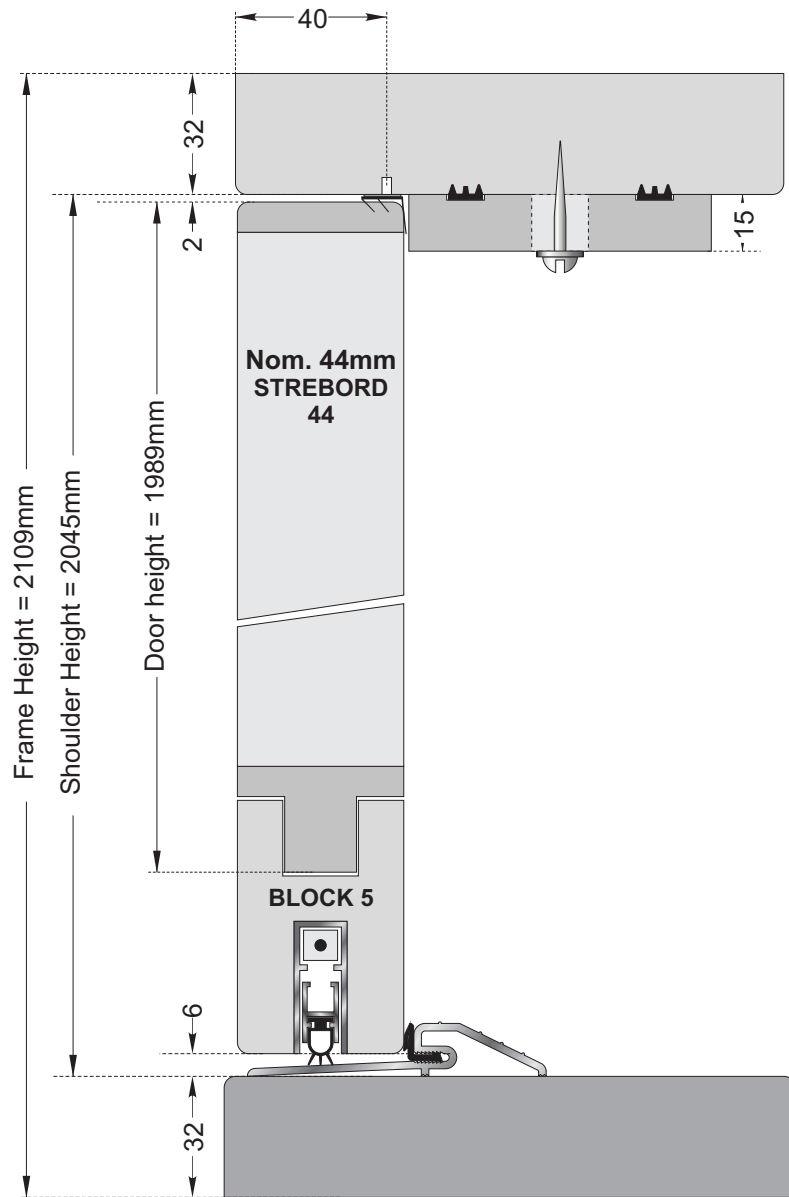

TEST 41: BLOCK 5 with NORSOUND 810 Drop Seal used with NORSOUND 650 combined Threshold with seal. = **Rw.33dB. SRL Test 66.**

Dwg. Ref:	Sk/AHP/160208/T009		
TITLE	NORSOUND Acoustic Tests Test 41 STREBORD 44		
Scale	1 : 2	Date	16/6/08
Revisions			

Tony Palmer *Smartech 2000*

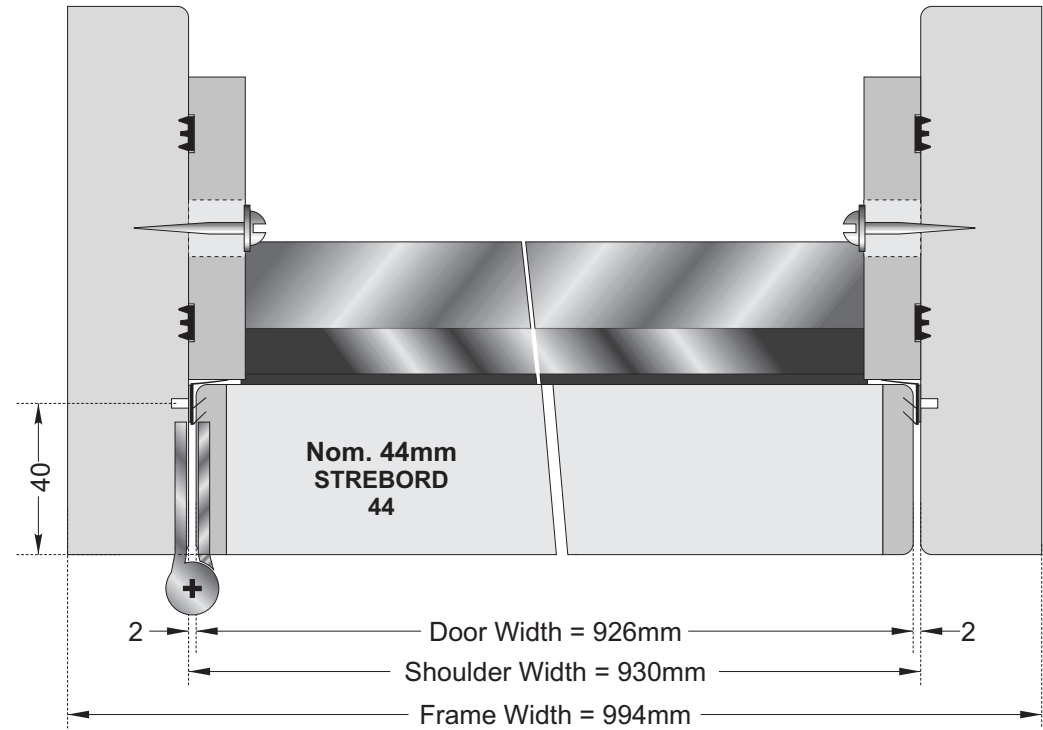
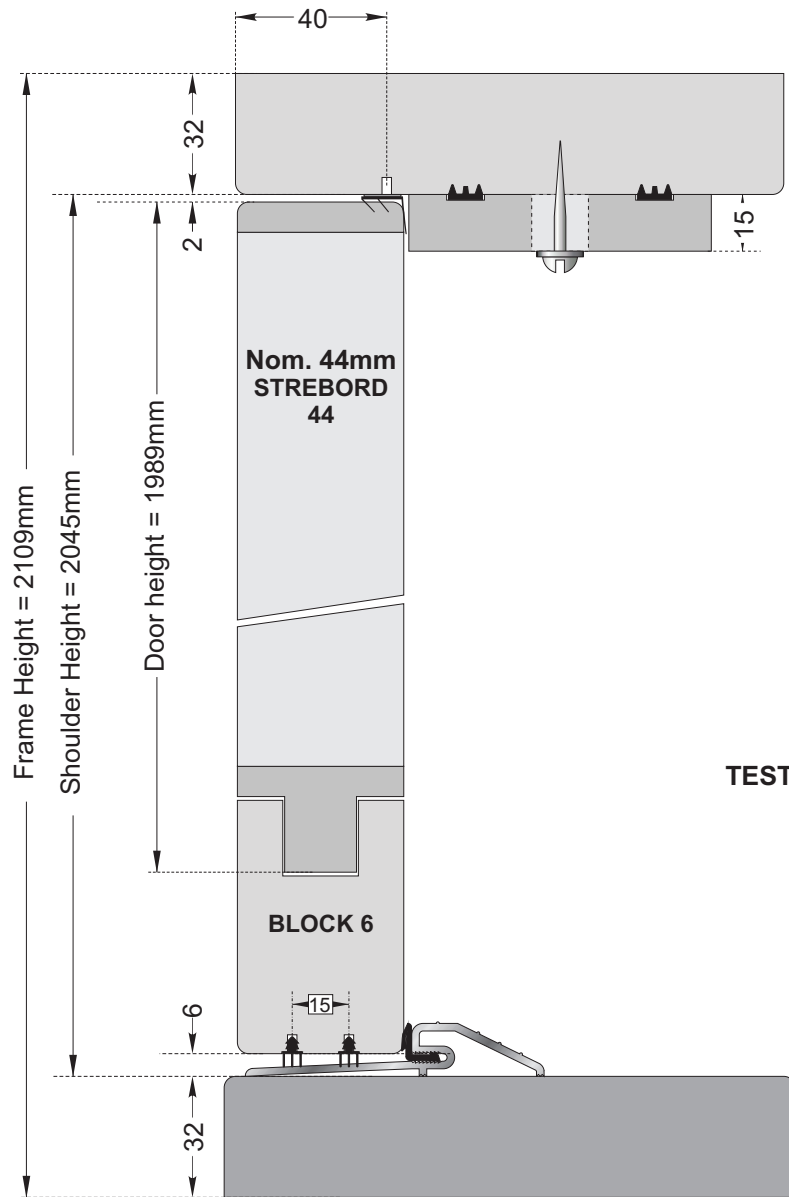

TEST 42: BLOCK 6 fitted with 2No. NORSOUND 720 Trident seals used with NORSOUND 650 combined Threshold with seal. = **Rw.33dB. SRL Test 67.**

Dwg. Ref:	Sk/AHP/160208/T010		
TITLE	NORSOUND Acoustic Tests Test 42 STREBORD 44		
Scale	1 : 2	Date	16/6/08
Revisions			

Tony Palmer
Specialist 2000

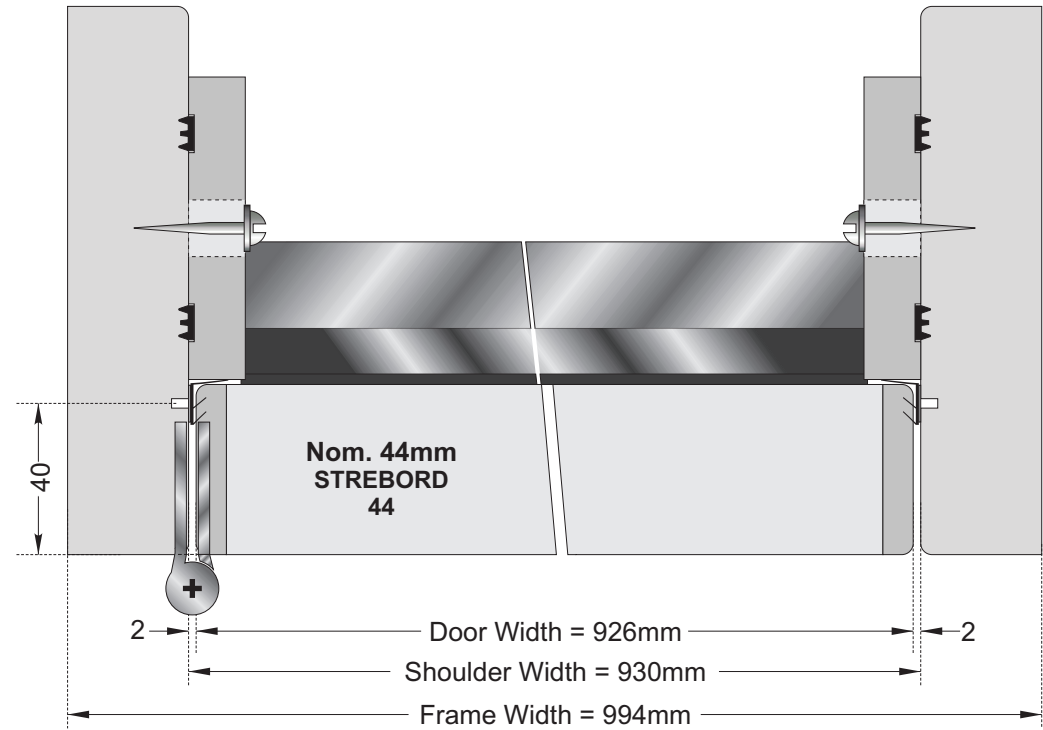
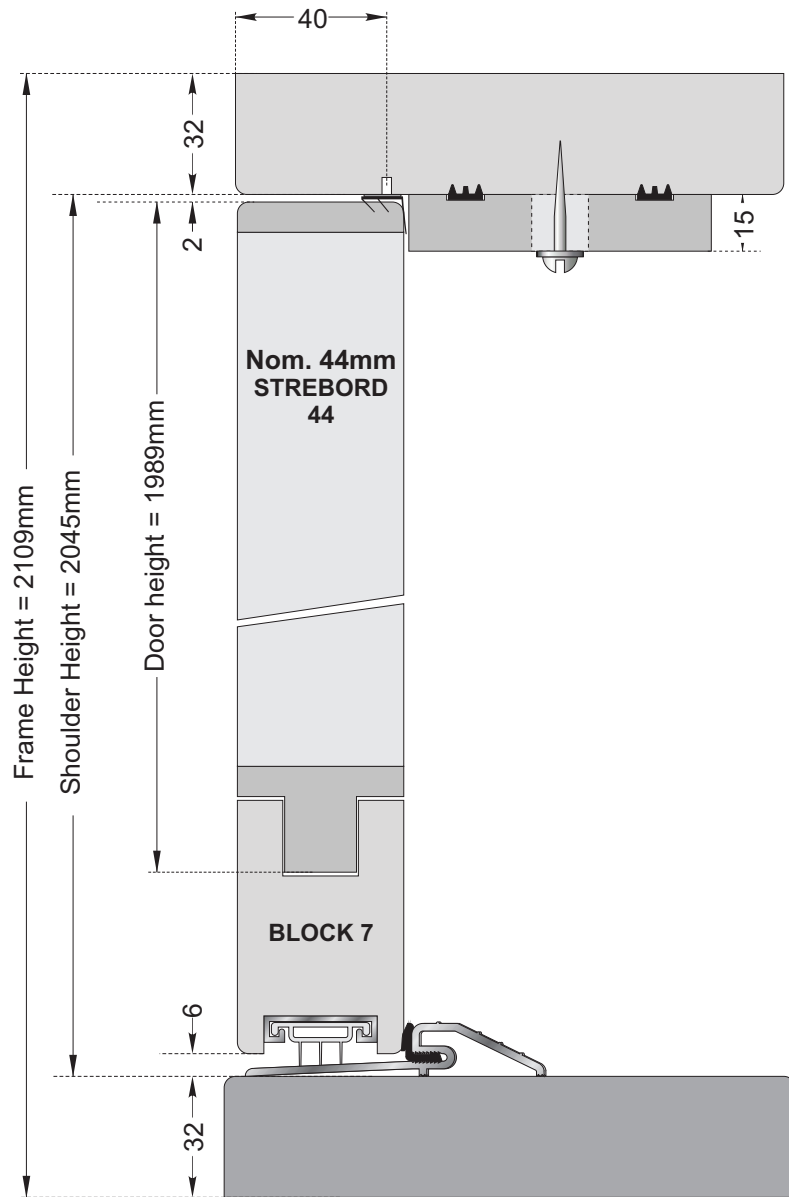

TEST 43: BLOCK 7 fitted with NORSOUND 850 Door Shoe used with NORSOUND 650 combined Threshold with seal. = **Rw.33dB. SRL Test 59.**

Dwg. Ref:	Sk/AHP/160208/T011		
TITLE	NORSOUND Acoustic Tests Test 43 STREBORD 44		
Scale	1 : 2	Date	16/6/08
Revisions			

Tony Palmer
Smartech 2000

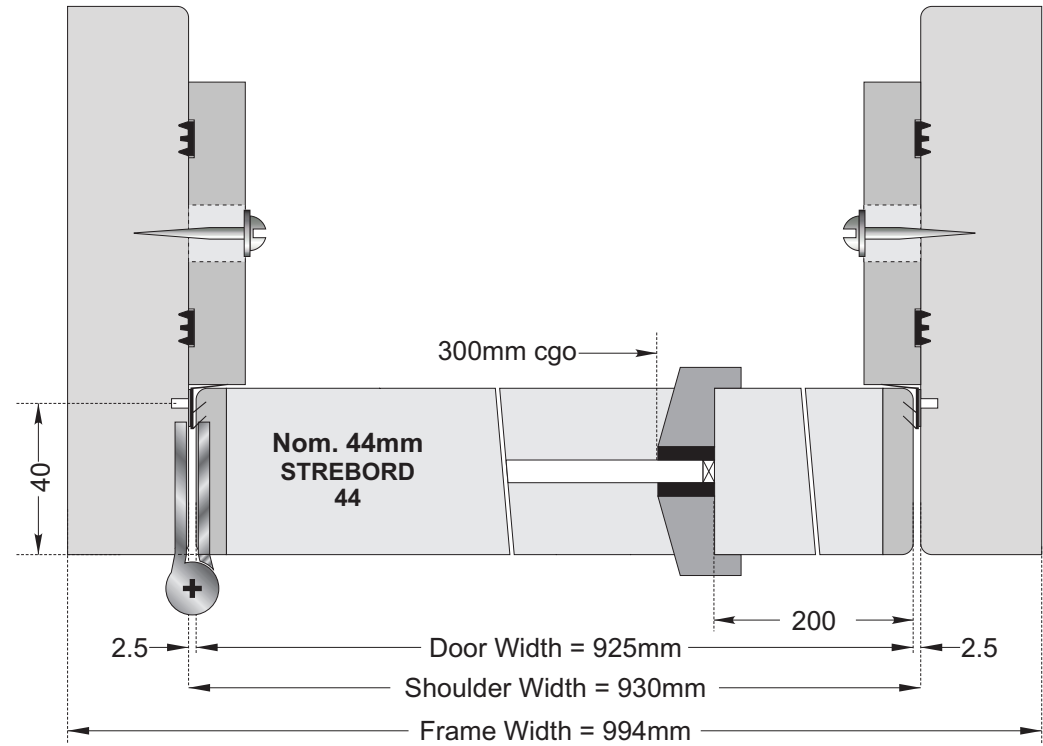
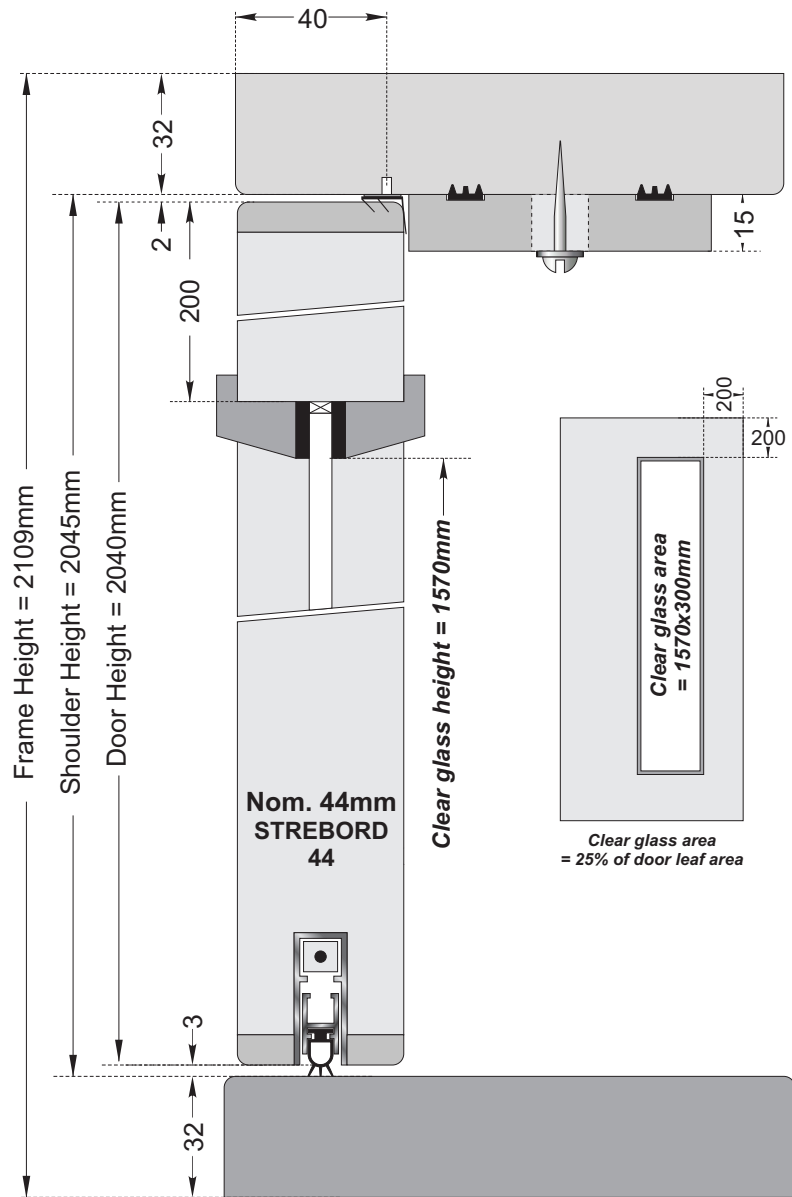

TEST 70: Nom. 6mm Pyroshield glass. NORSOUND 710 to Head & Jamb.
NORSOUND 810 to Threshold. = **Rw.32dB. SRL Test 53.**

Dwg. Ref:	Sk/AHP/160208/T012		
TITLE	NORSOUND Acoustic Tests Test 70 STREBORD 44		
Scale	1 : 2	Date	16/6/08
Revisions			

Tony Palmer
Specialist 2000

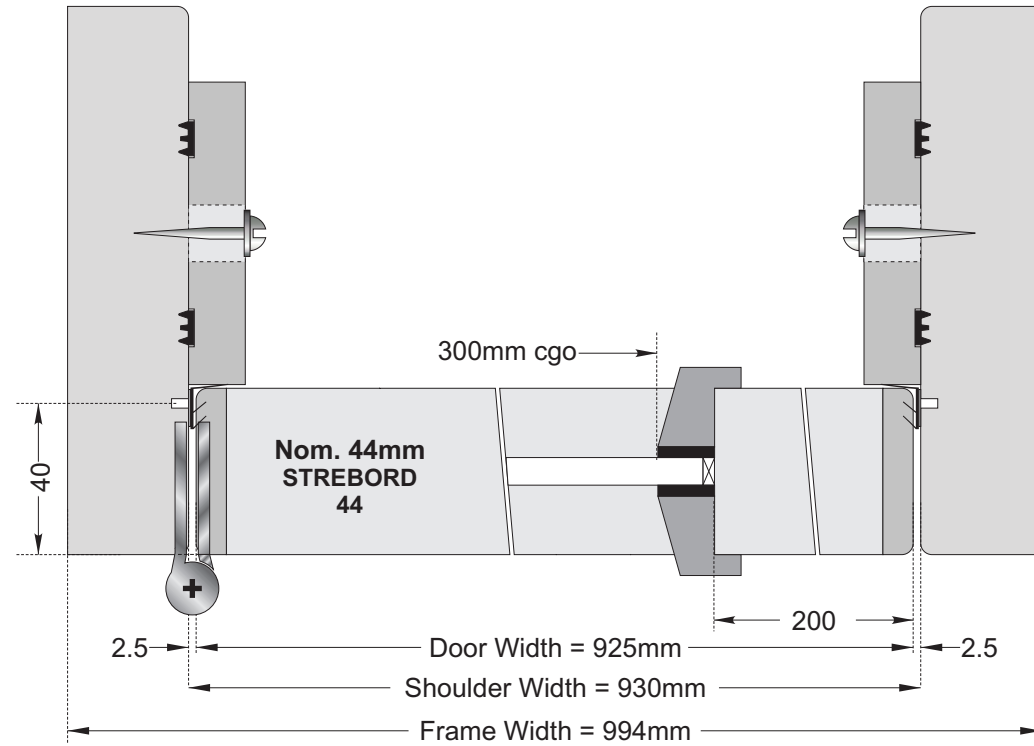
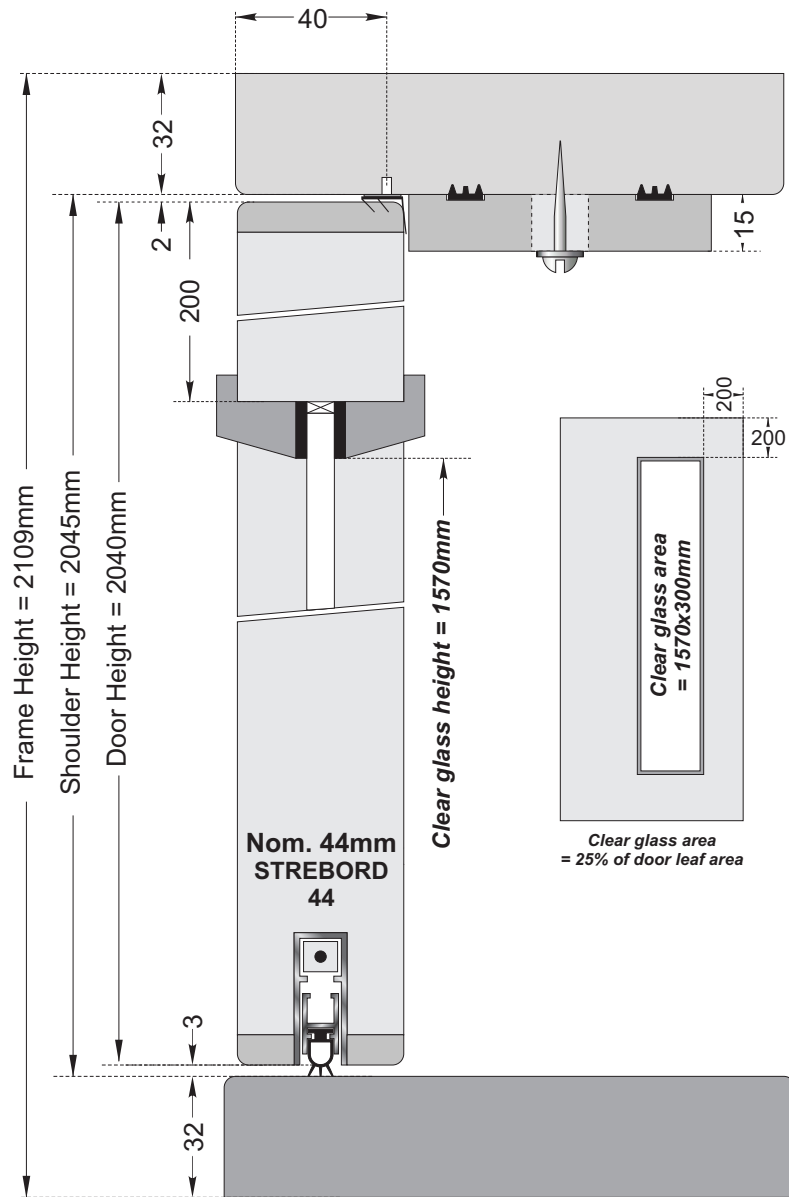

TEST 71: Nom. 7.3mm Pyrobelite glass. NORSOUND 710 to Head & Jambs.
 NORSOUND 810 to Threshold. = **Rw.33dB. SRL Test 54.**

Dwg. Ref:	Sk/AHP/160208/T013		
TITLE	NORSEAL Acoustic Tests Test 71 STREBORD 44		
Scale	1 : 2	Date	16/6/08
Revisions			

Tony Palmer
Specialist 2000

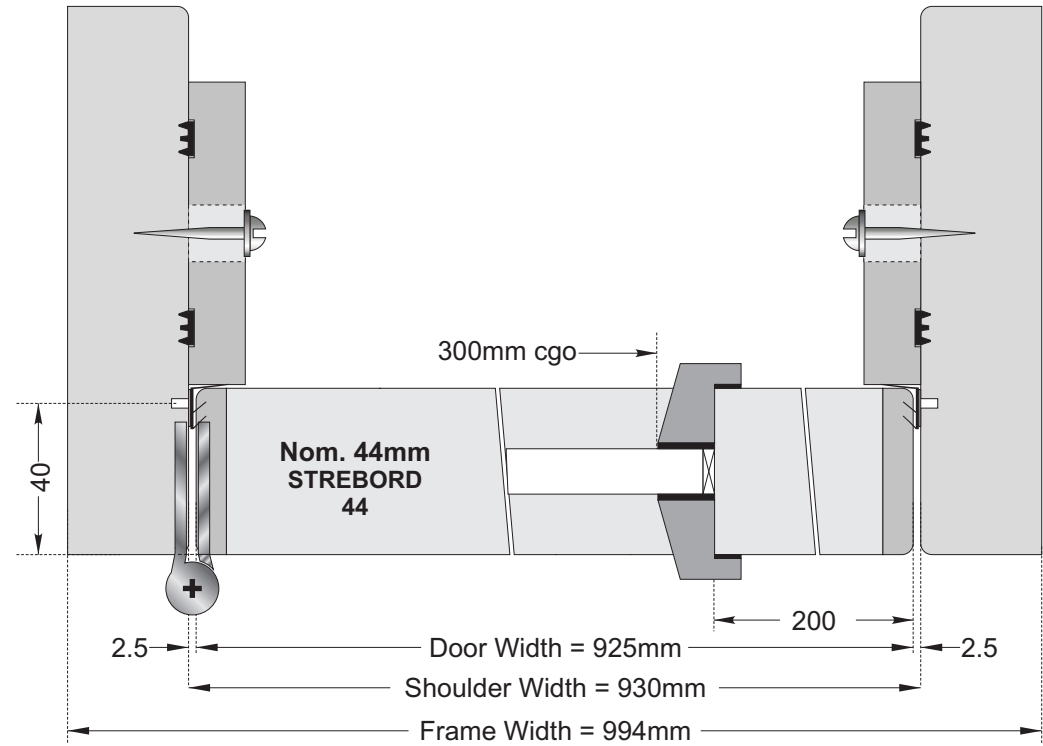
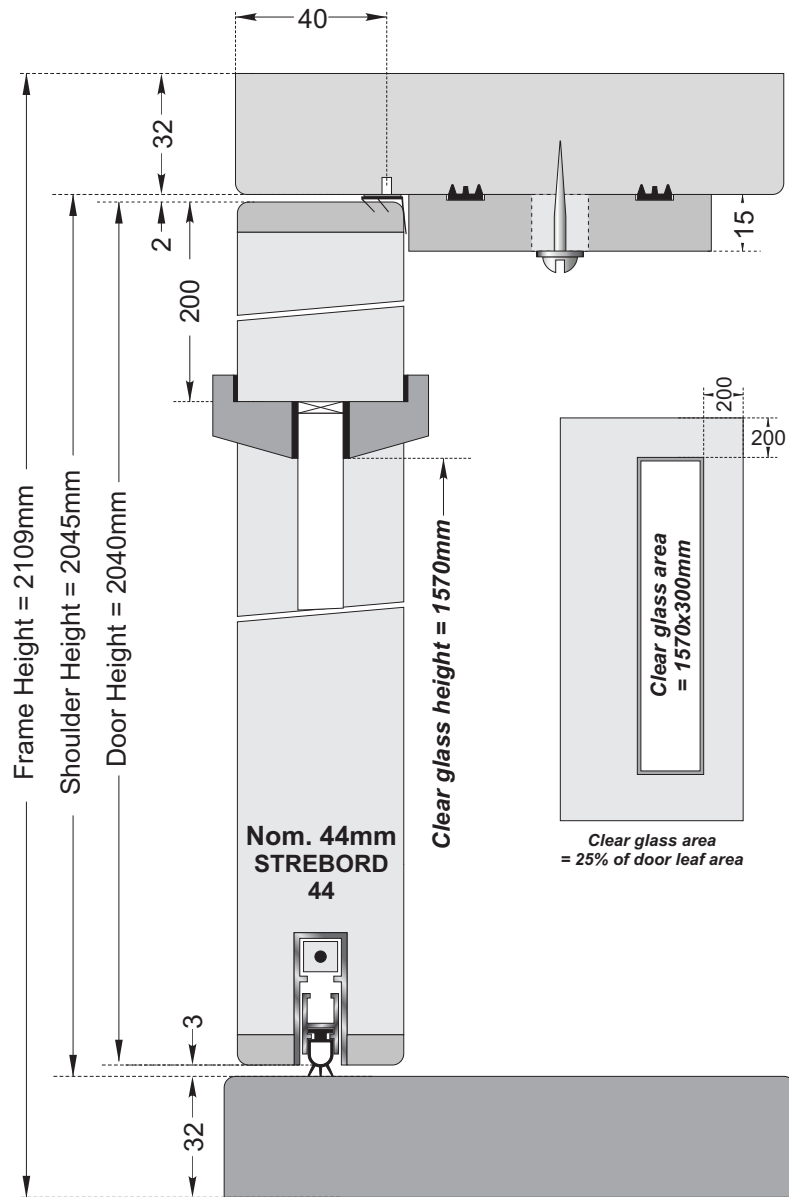

TEST 72a: Nom. 12mm Pyrobelite glass. NORSOUND 710 to Head & Jamb.
NORSOUND 810 to Threshold. = **Rw.34dB. SRL Test 45.**

Dwg. Ref:	Sk/AHP/160208/T014		
TITLE	NORSOUND Acoustic Tests Test 72a STREBORD 44		
Scale	1 : 2	Date	16/6/08
Revisions			

Tony Palmer
Invented 2000

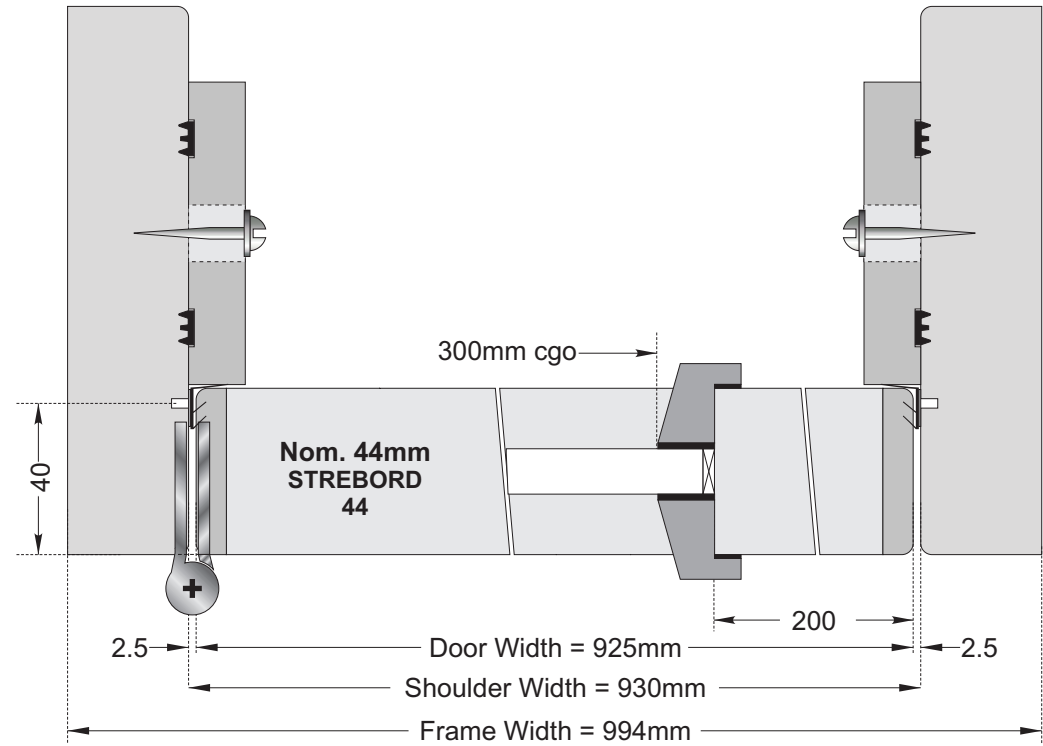
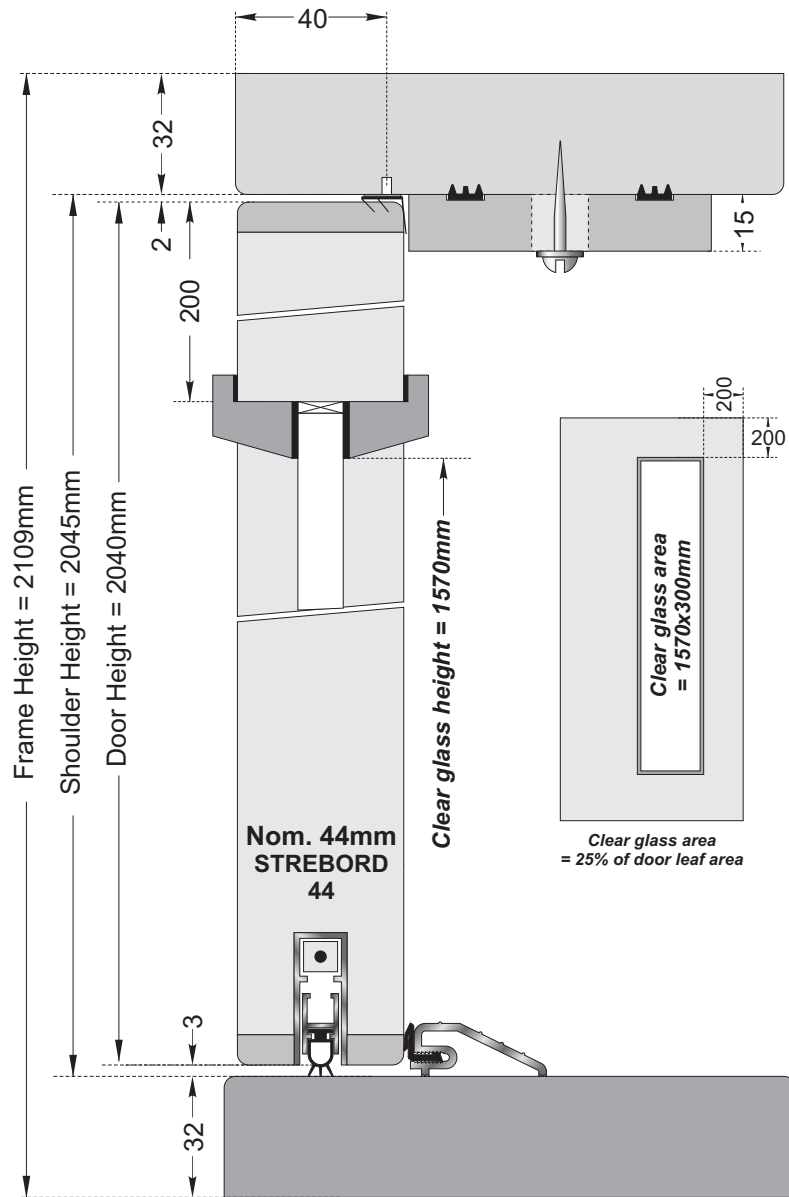

TEST 72b & c: Nom. 12mm Pyrobelite glass. NORSOUND 710 to Head & Jamb.
NORSOUND 810 + (modified) NORSOUND 650 to Threshold.
= Rw.34dB. SRL Test 46 & 47.

Dwg. Ref:	Sk/AHP/160208/T015		
TITLE	NORSOUND Acoustic Tests Test 72b & 72c STREBORD 44		
Scale	1 : 2	Date	16/6/08
Revisions			

Tony Palmer
Inventor 2000

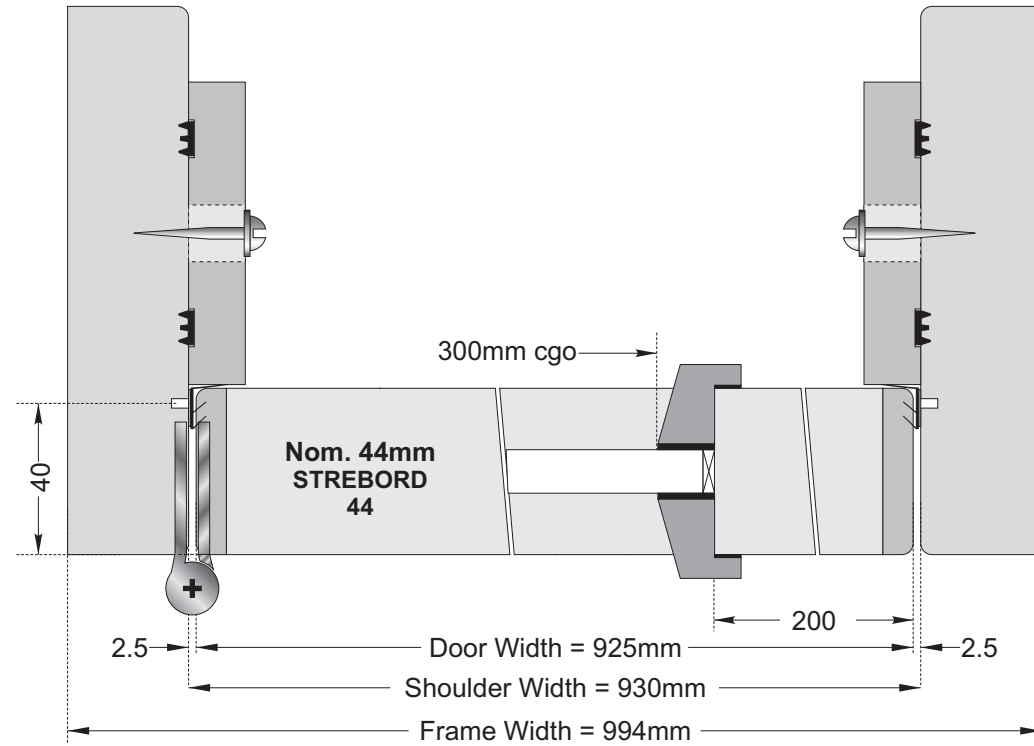
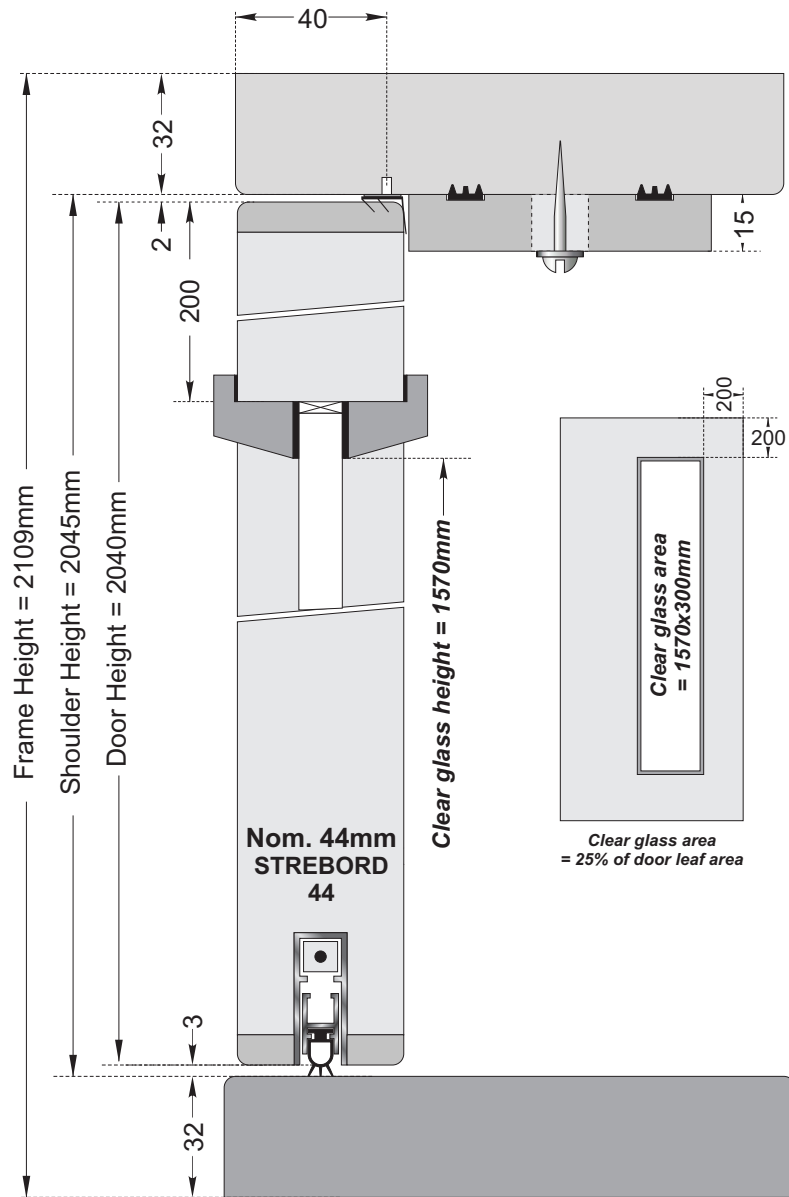

TEST 74a: Nom. 11.5mm 3 Ply PA Res. glass. NORSOUND 710 to Head & Jambs NORSOUND 810.
= **Rw.34dB. SRL Test 44.**

Dwg. Ref:	Sk/AHP/160208/T016		
TITLE	NORSOUND Acoustic Tests Test 74a STREBORD 44		
Scale	1 : 2	Date	16/6/08
Revisions			

Tony Palmer
Invented 2000

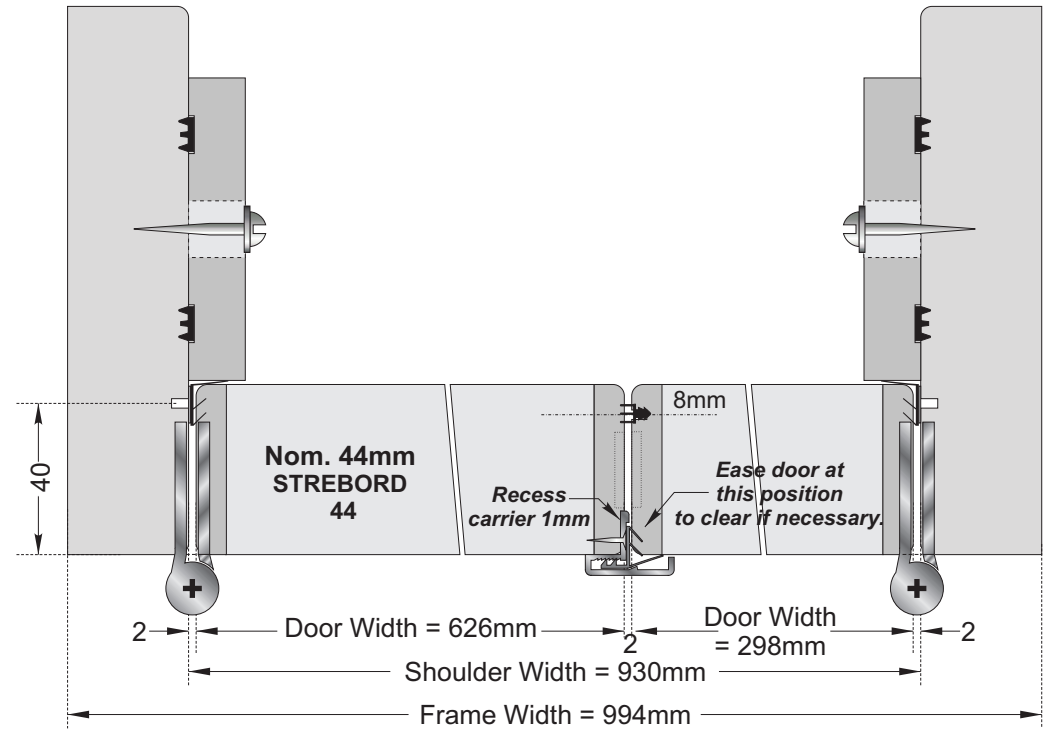
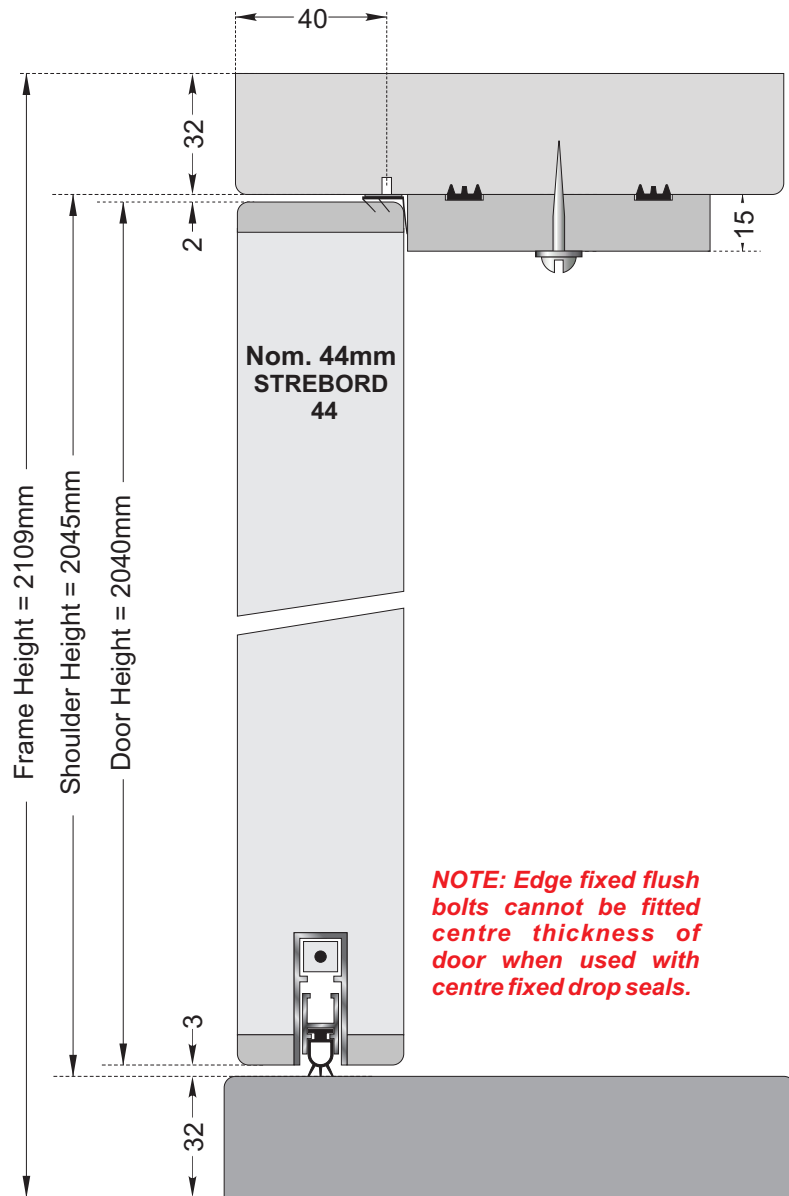

TEST 92: NORSOUND 710 to Head & Jambs + NORSOUND 810 to threshold of each door.
NORSOUND 720 and NORSOUND 510 at Meeting Stiles.
= Rw.32dB. SRL Test 74.

Dwg. Ref:	Sk/AHP/160208/T017		
TITLE	NORSOUND Acoustic Tests Test 92 STREBORD 44		
Scale	1 : 2	Date	16/6/08
Revisions			

Tony Palmer
Invented 2000

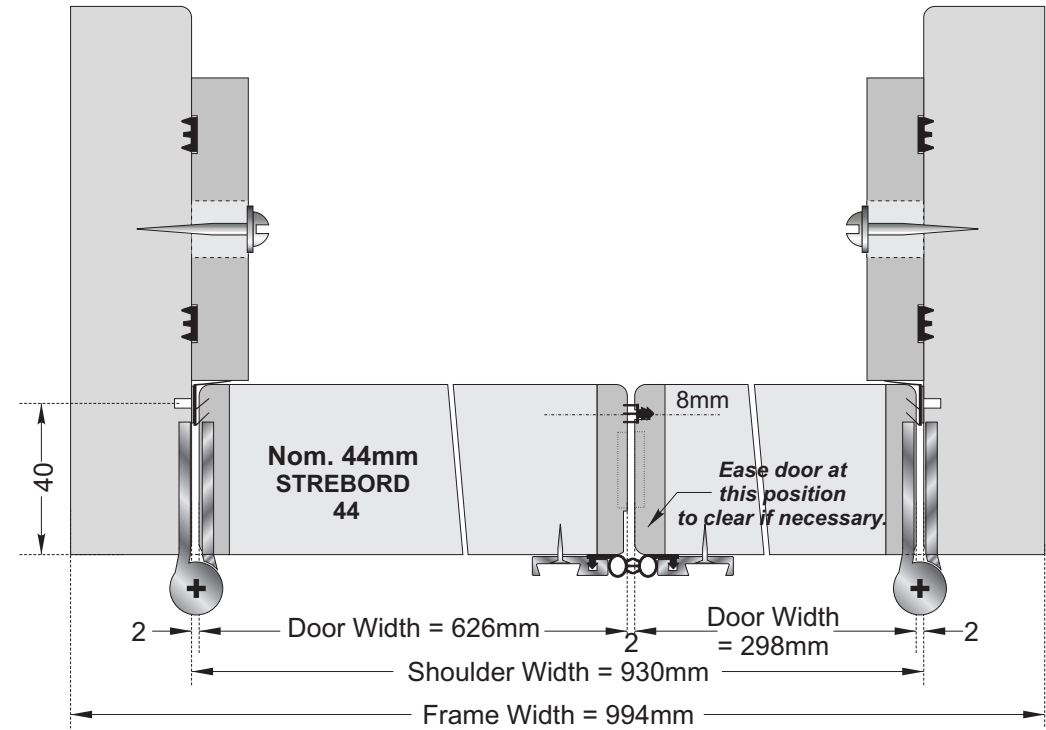
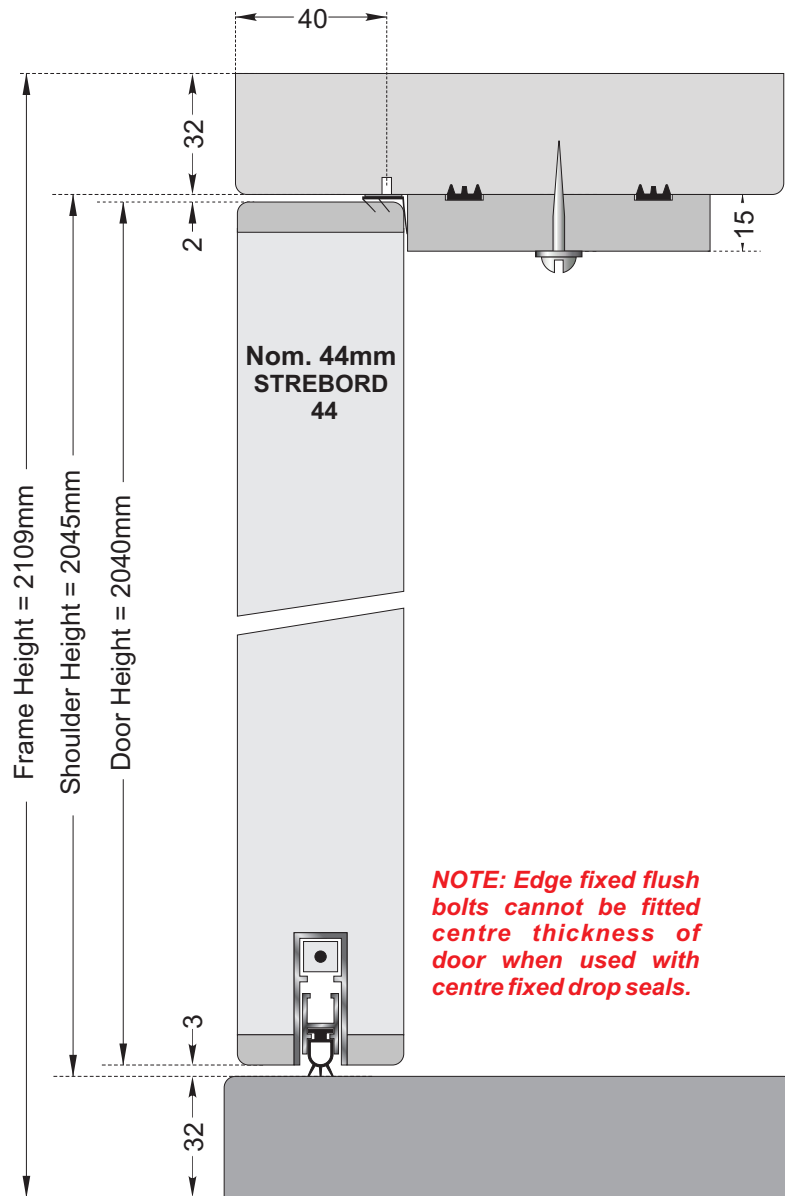

TEST 93: NORSOUND 710 to Head & Jambs + NORSOUND 810 to threshold of each door.
 NORSOUND 720 and 2No. NORSOUND 755 at Meeting Stiles.
 = **Rw.33dB. SRL Test 75.**

Dwg. Ref:	Sk/AHP/160208/T018		
TITLE	NORSOUND Acoustic Tests Test 93 STREBORD 44		
Scale	1 : 2	Date	16/6/08
Revisions			

Tony Palmer
Specialist 2000

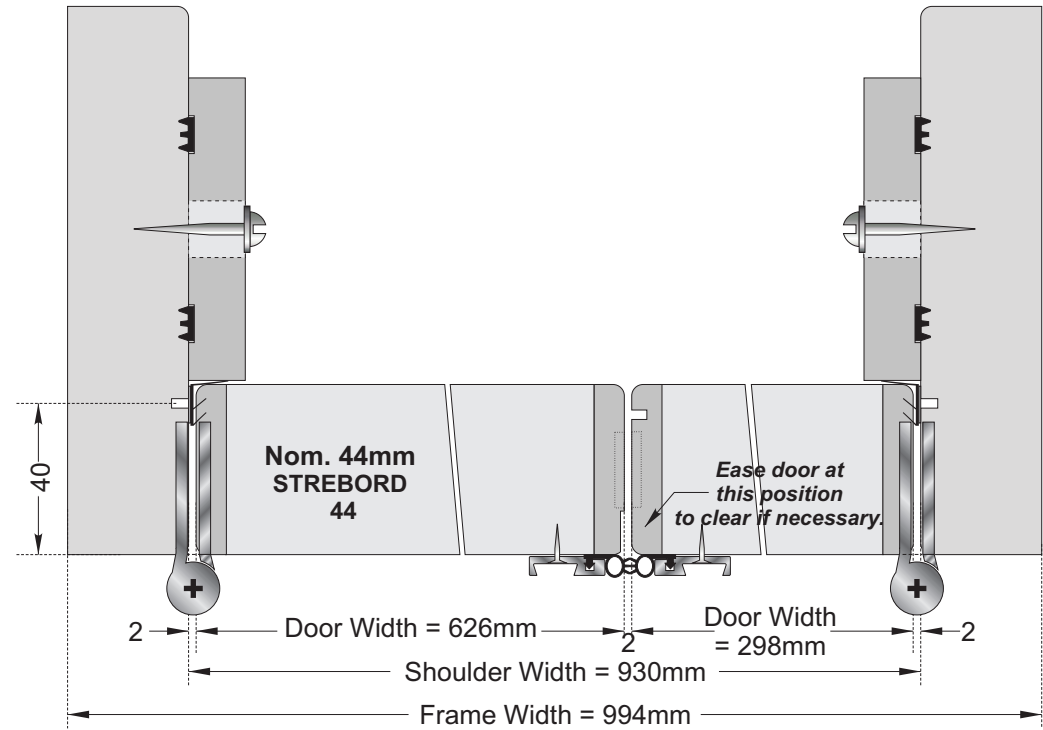
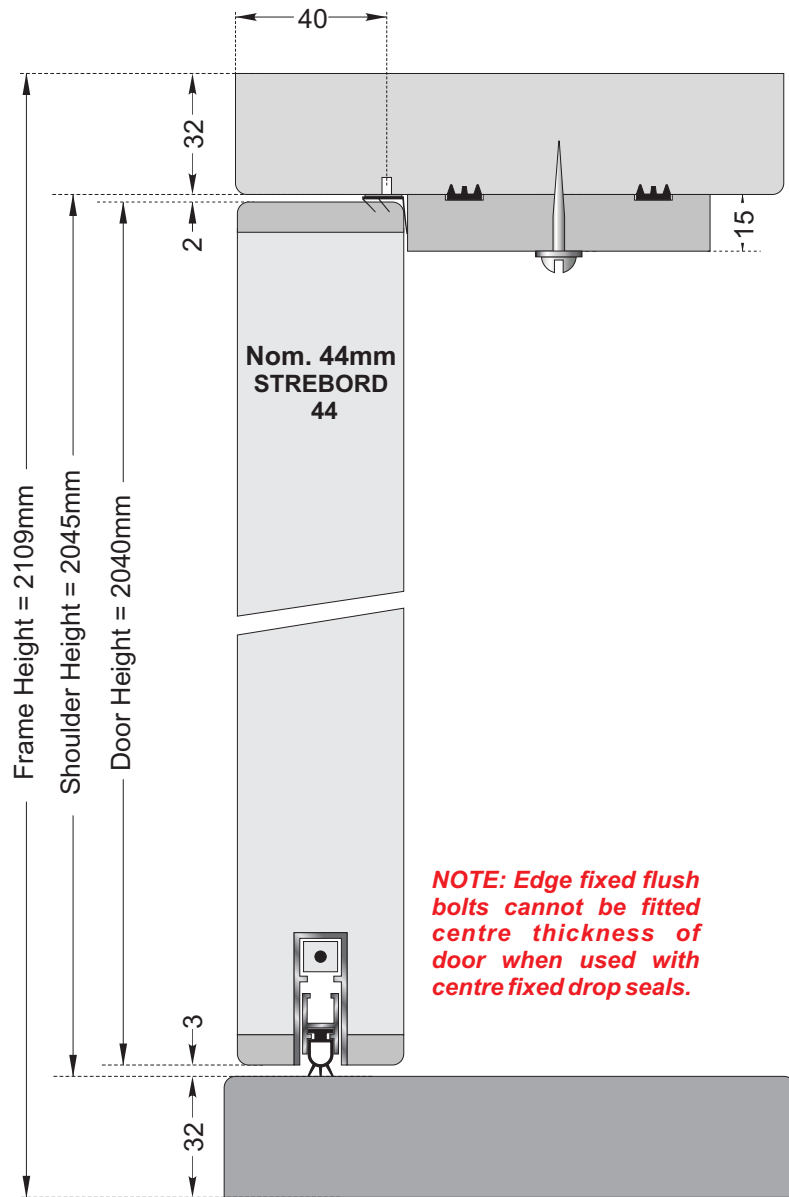

TEST 93a: NORSOUND 710 to Head & Jambs + NORSOUND 810 to threshold of each door.
2No. NORSOUND 755 at Meeting Stiles. = Rw.32dB. SRL Test 76.

Dwg. Ref:	Sk/AHP/160208/T019		
TITLE	NORSOUND Acoustic Tests Test 93a STREBORD 44		
Scale	1 : 2	Date	16/6/08
Revisions			

Tony Palmer
Inventor 2000

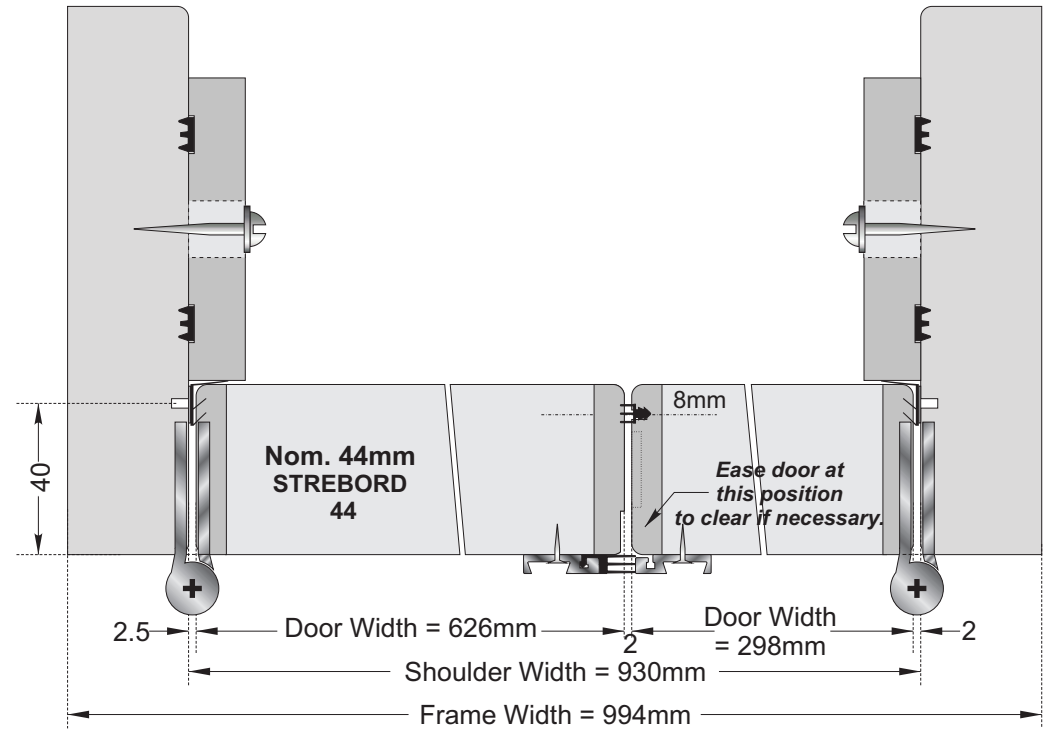
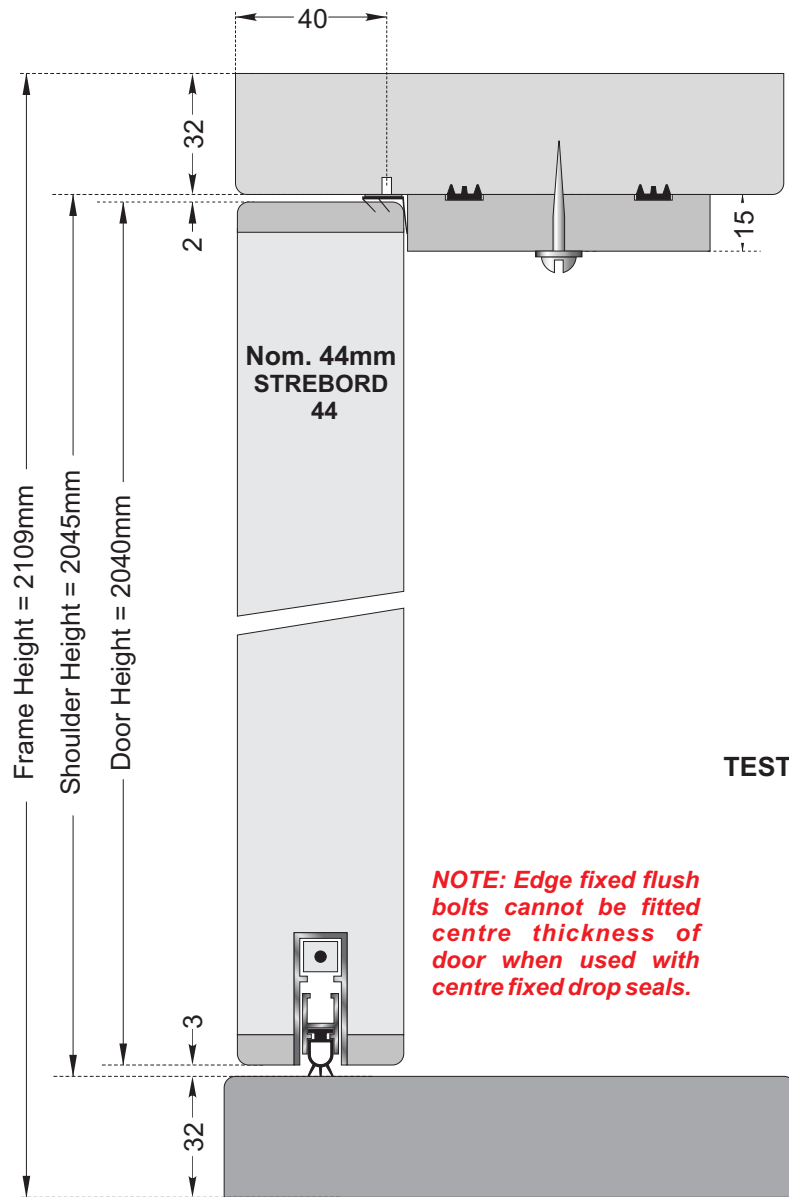

TEST 94: NORSOUND 710 to Head & Jambs + NORSOUND 810 to threshold of each door.
NORSOUND 855 + NORSOUND 855 Carrier only + NORSOUND 720 at Meeting Stiles.
= Rw.33dB. SRL Test 77.

Dwg. Ref:	Sk/AHP/160208/T020		
TITLE	NORSOUND Acoustic Tests Test 94 STREBORD 44		
Scale	1 : 2	Date	16/6/08
Revisions			

Tony Palmer
Invented 2000

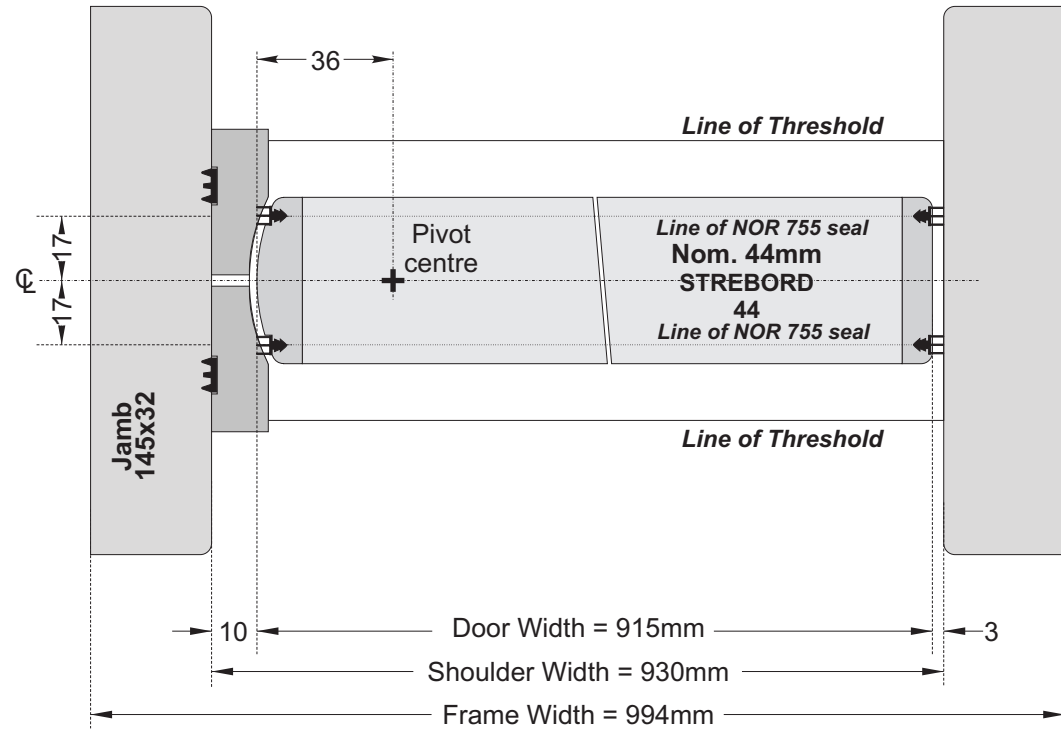
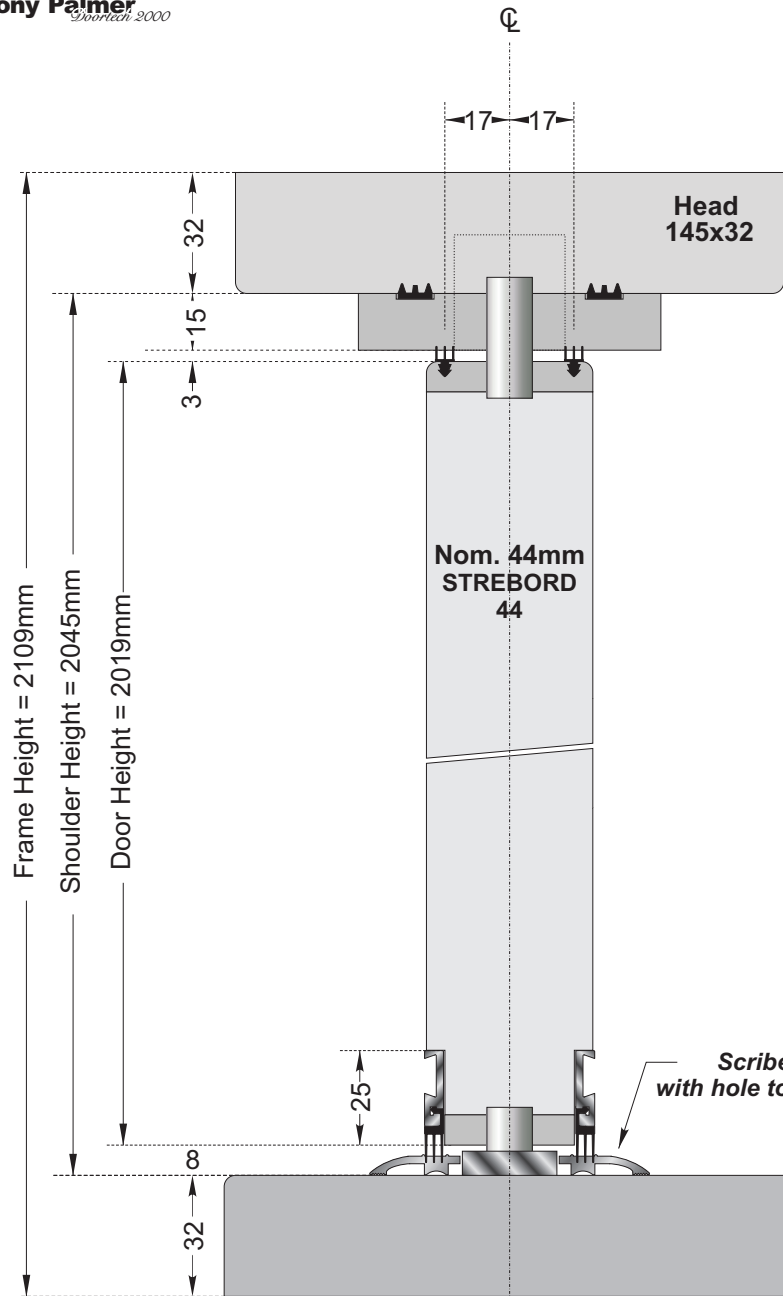

TEST 102: Fully Caulked Double Action. = **Rw.33dB. SRL Test 110.**

TEST 103: Twin row NORSOUND 720 to Jamb & Head. Twin NORSOUND 855 seals recessed into face at the bottom of the door used with NORSOUND 620 Threshold plate scribed to suit R&T 36mm centre pivot fixings = **Rw.32dB. SRL Test 111.**

Dwg. Ref:	Sk/AHP/160208/T021		
TITLE	NORSOUND Acoustic Tests Test 102 & 103 STREBORD 44		
Scale	1 : 2	Date	16/6/08
Revisions			

Tony Palmer
Invented 2000

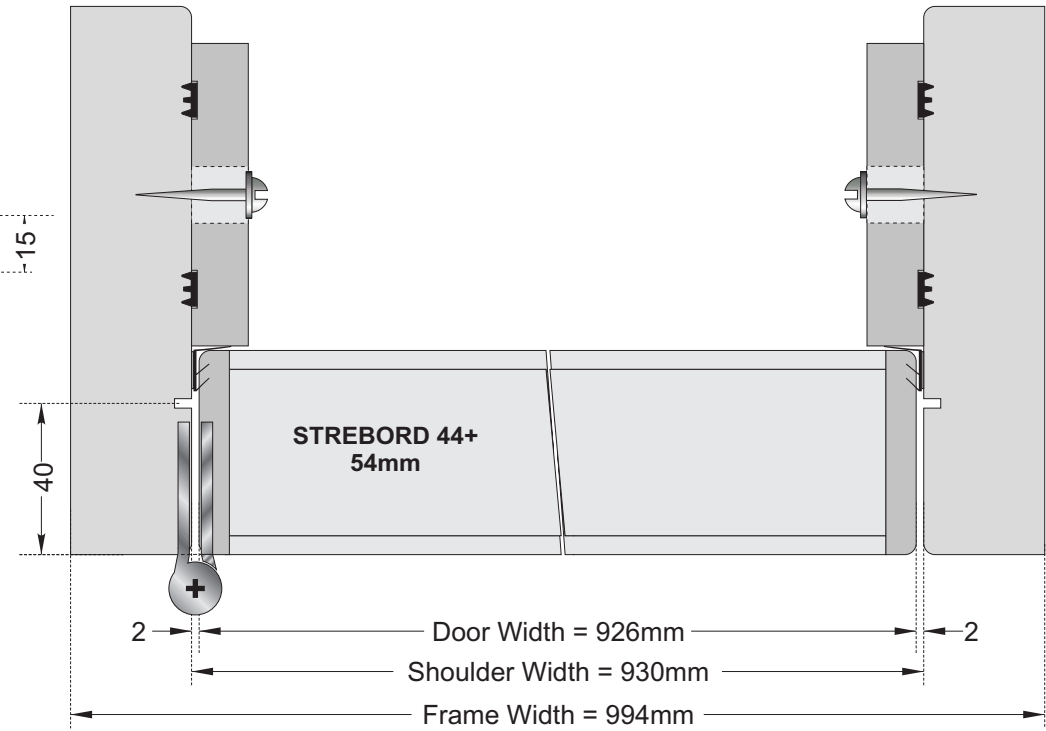
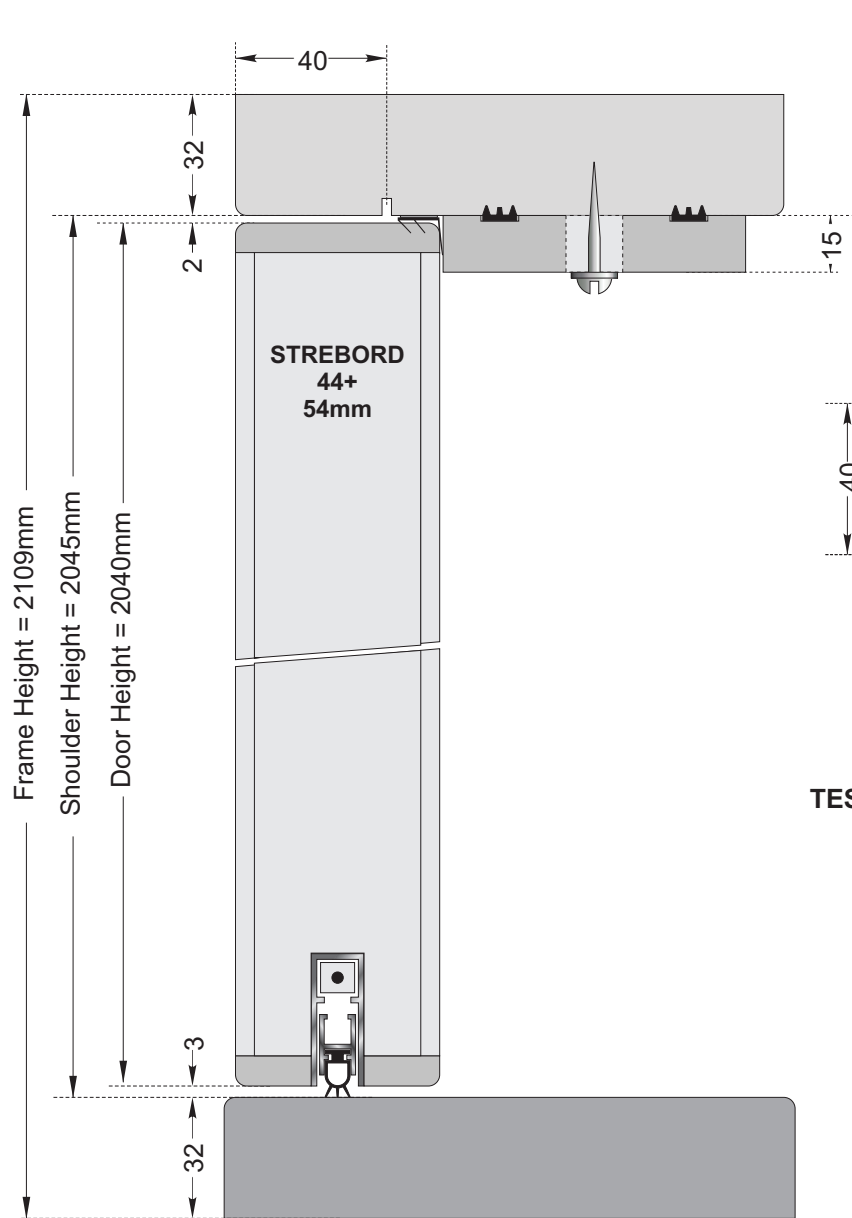

TEST 19: STREBORD 44+ (54mm) door. Fully caulked test. = **Rw.35dB. SRL Test 29.**

Dwg. Ref:	Sk/AHP/160208/T022		
TITLE	NORSOUND Acoustic Tests Test 19 STREBORD 44		
Scale	1 : 2	Date	16/6/08
Revisions			

Tony Palmer
invented 2000

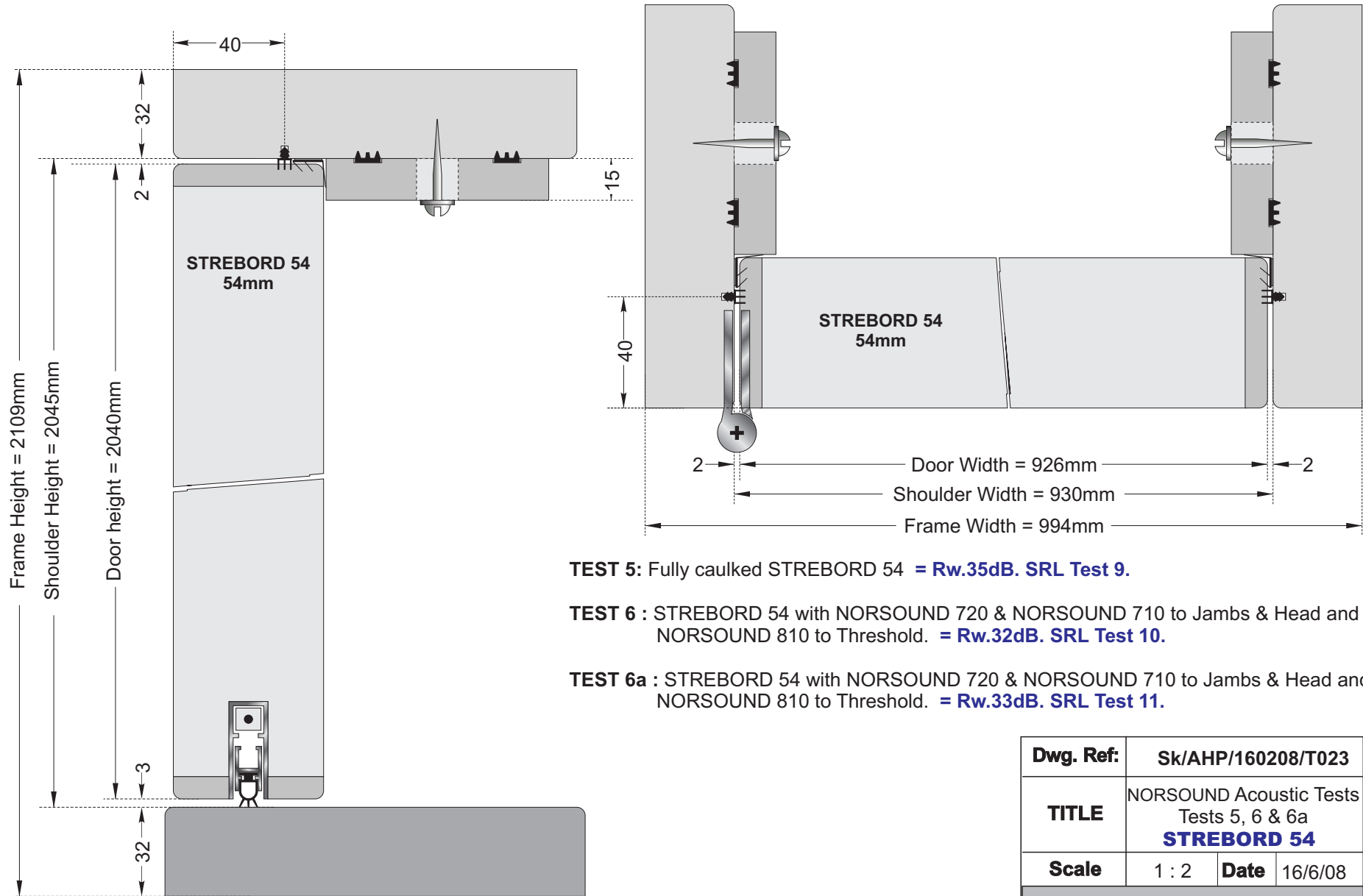

TEST 5: Fully caulked STREBORD 54 = **Rw.35dB. SRL Test 9.**

TEST 6 : STREBORD 54 with NORSOUND 720 & NORSOUND 710 to Jambs & Head and NORSOUND 810 to Threshold. = **Rw.32dB. SRL Test 10.**

TEST 6a : STREBORD 54 with NORSOUND 720 & NORSOUND 710 to Jambs & Head and NORSOUND 810 to Threshold. = **Rw.33dB. SRL Test 11.**

Dwg. Ref:	Sk/AHP/160208/T023		
TITLE	NORSOUND Acoustic Tests Tests 5, 6 & 6a STREBORD 54		
Scale	1 : 2	Date	16/6/08
Revisions			

Tony Palmer
Smartech 2000

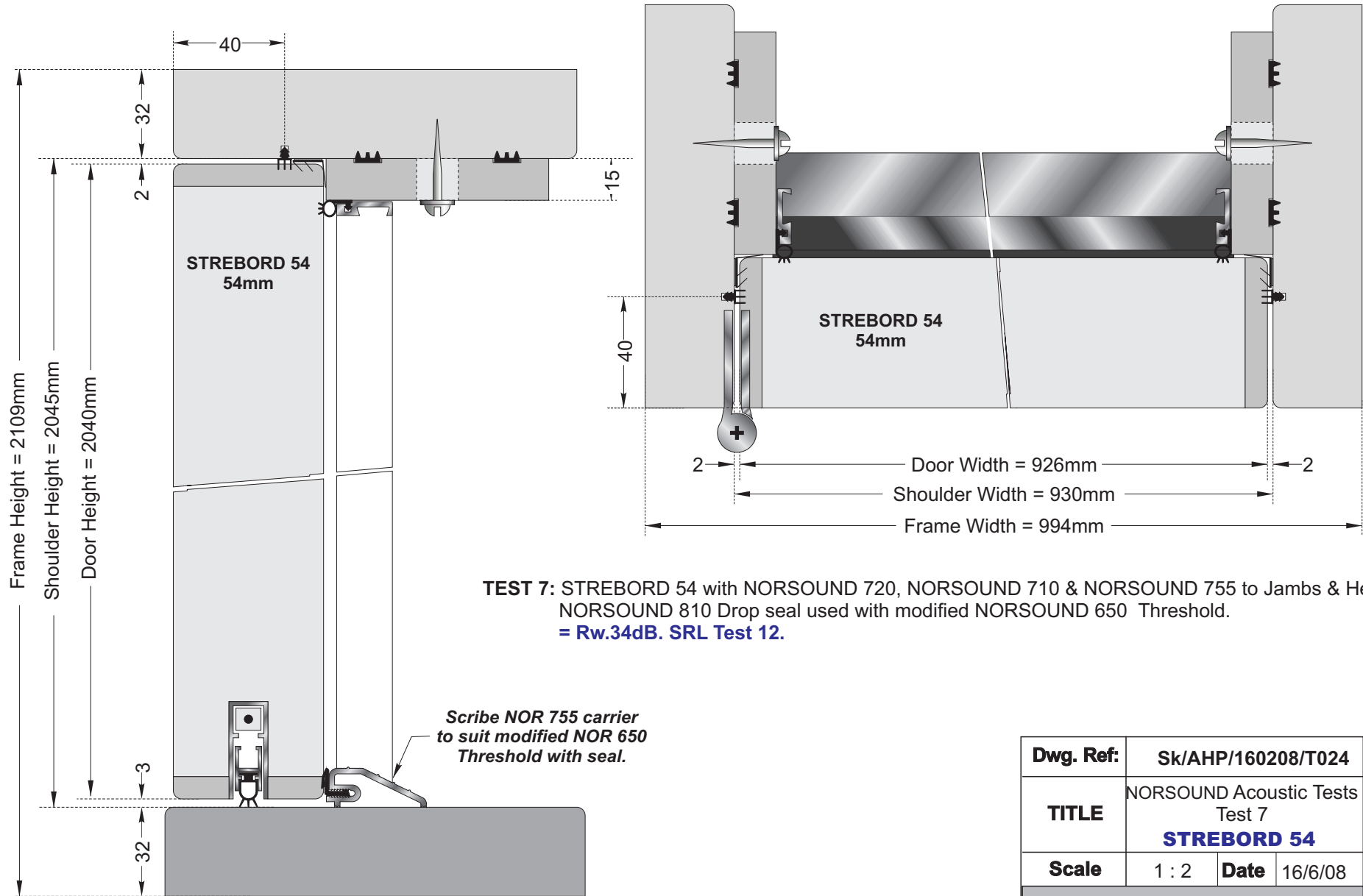

TEST 7: STREBORD 54 with NORSOUND 720, NORSOUND 710 & NORSOUND 755 to Jambs & Head
NORSOUND 810 Drop seal used with modified NORSOUND 650 Threshold.
= Rw.34dB. SRL Test 12.

Dwg. Ref:	Sk/AHP/160208/T024		
TITLE	NORSOUND Acoustic Tests Test 7 STREBORD 54		
Scale	1 : 2	Date	16/6/08
Revisions			

Tony Palmer
Invented 2000

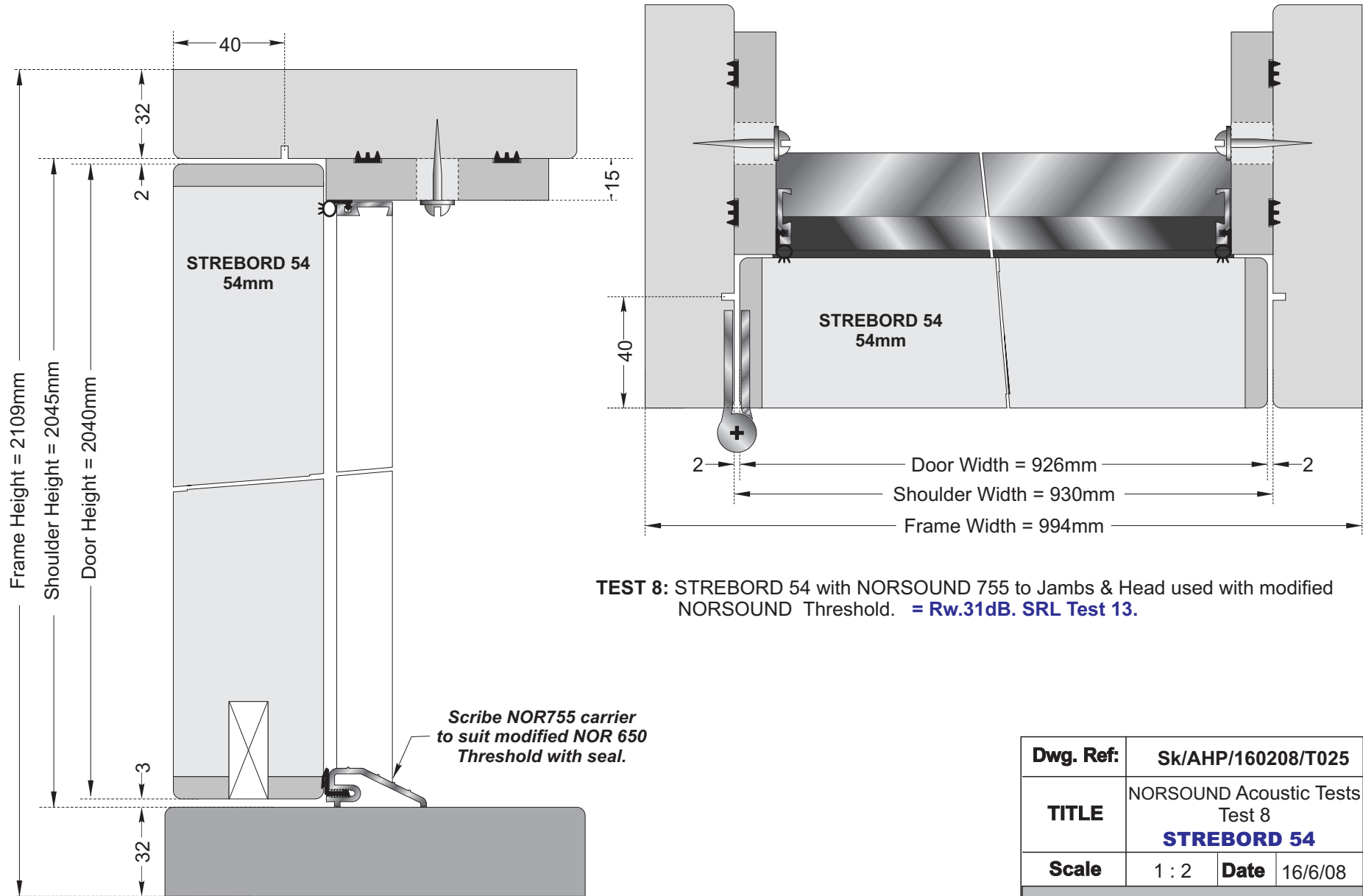

TEST 8: STREBORD 54 with NORSOUND 755 to Jambs & Head used with modified NORSOUND Threshold. = Rw.31dB. SRL Test 13.

Dwg. Ref:	Sk/AHP/160208/T025		
TITLE	NORSOUND Acoustic Tests Test 8 STREBORD 54		
Scale	1 : 2	Date	16/6/08
Revisions			

Tony Palmer
Invented 2000

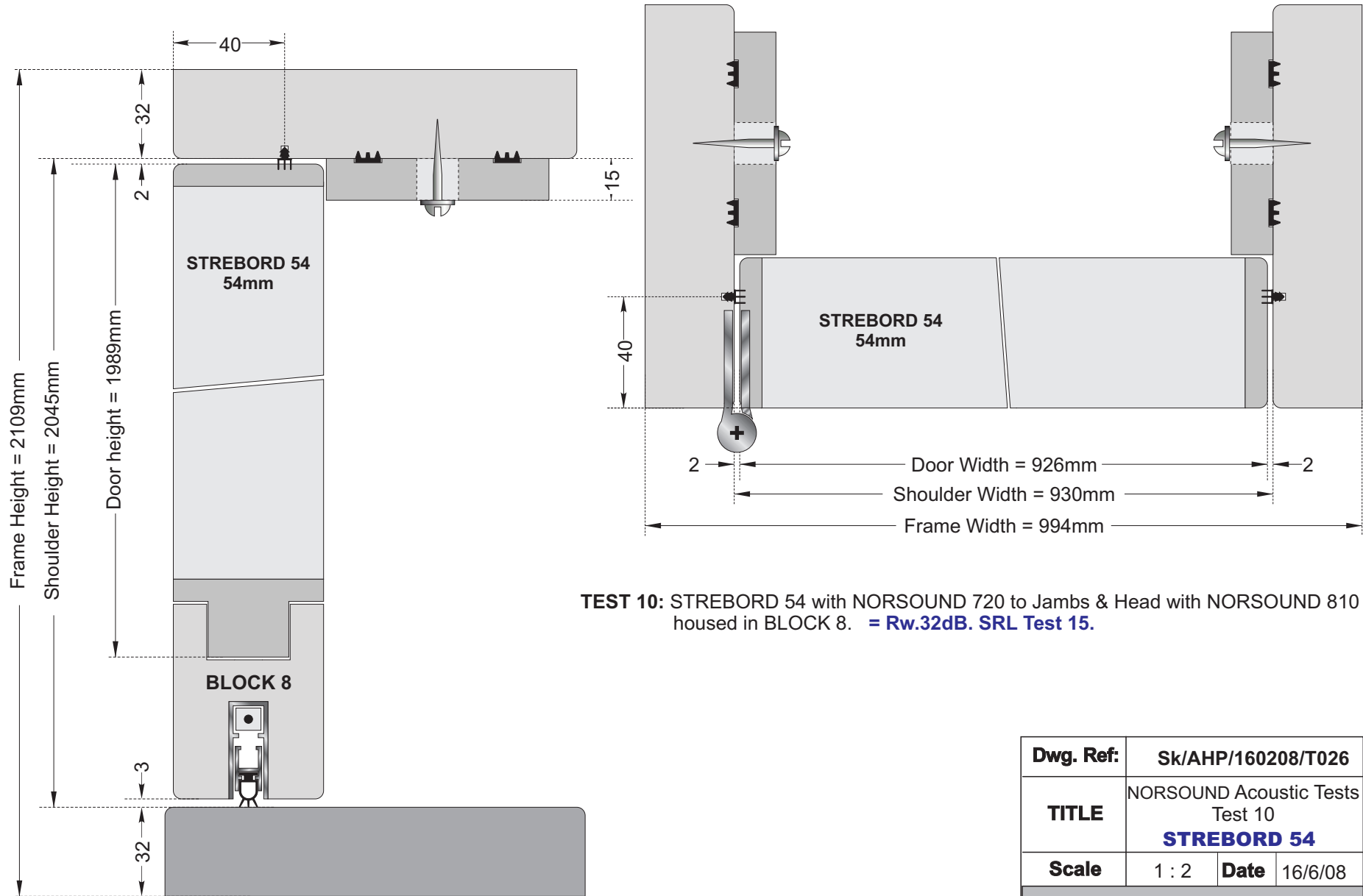

TEST 10: STREBORD 54 with NORSOUND 720 to Jambs & Head with NORSOUND 810 housed in BLOCK 8. = **Rw.32dB. SRL Test 15.**

Dwg. Ref:	Sk/AHP/160208/T026		
TITLE	NORSOUND Acoustic Tests Test 10 STREBORD 54		
Scale	1 : 2	Date	16/6/08
Revisions			

Tony Palmer
Smartech 2000

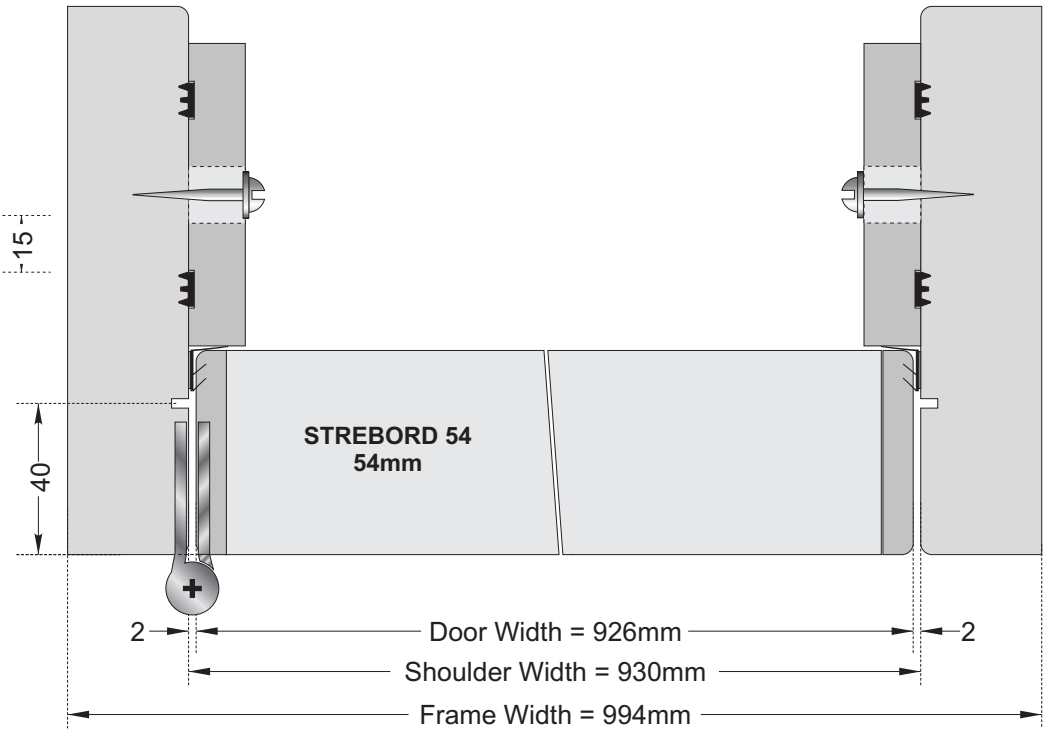
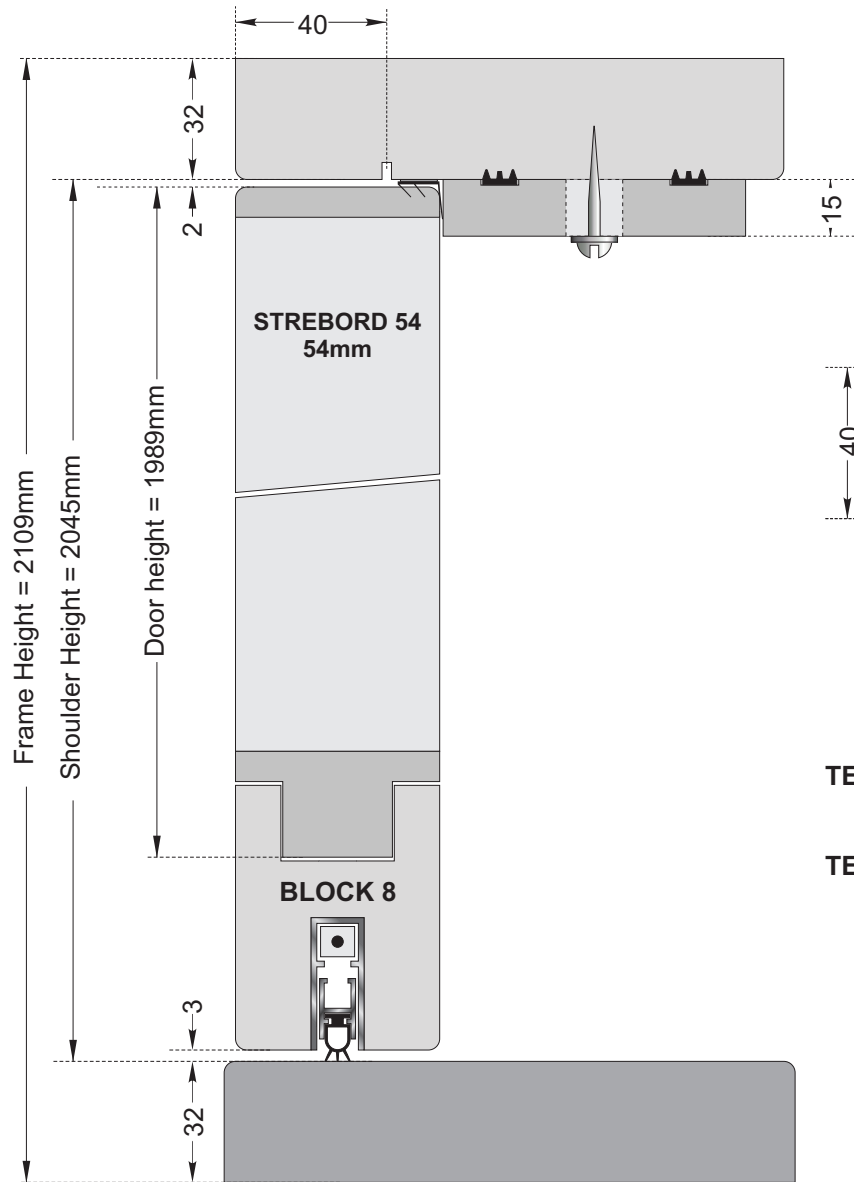

TEST 11: STREBORD 54 with NORSOUND 710 to Jambs & Head with NORSOUND 810 housed in BLOCK 8. = **Rw.32dB. SRL Test 16.**

TEST 11a: Repeat of Test 11 following adjustment. = **Rw.32dB. SRL Test 17.**

Dwg. Ref:	Sk/AHP/160208/T027		
TITLE	NORSOUND Acoustic Tests Test 11 & 11a STREBORD 54		
Scale	1 : 2	Date	16/6/08
Revisions			

Tony Palmer
Smartech 2000

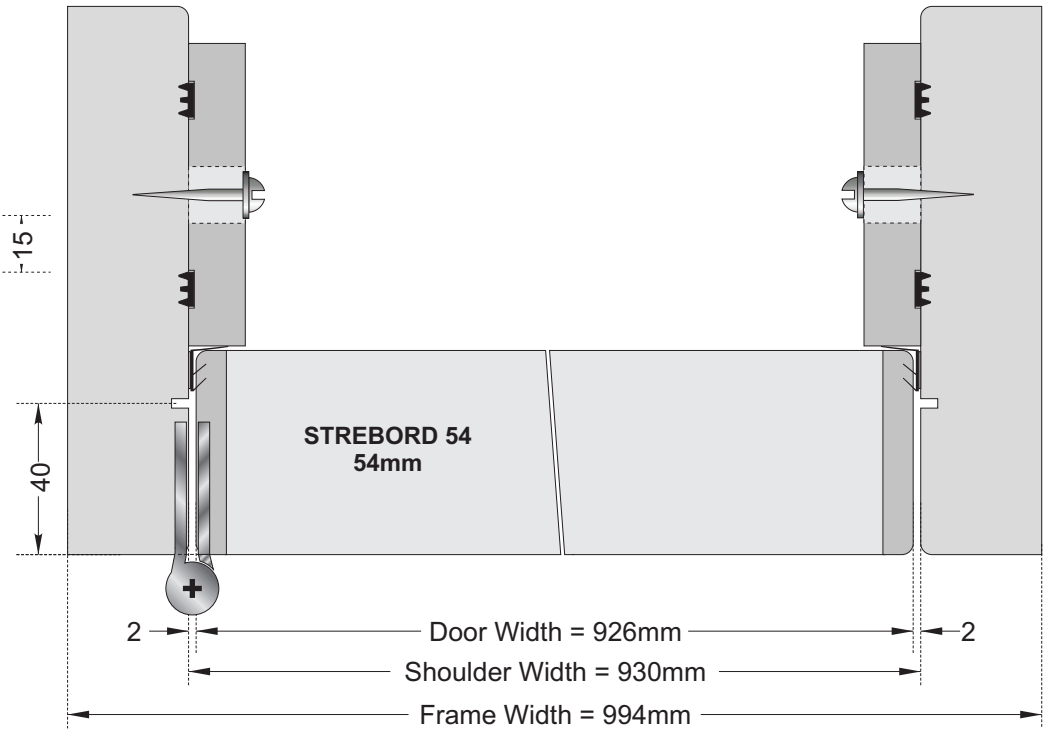
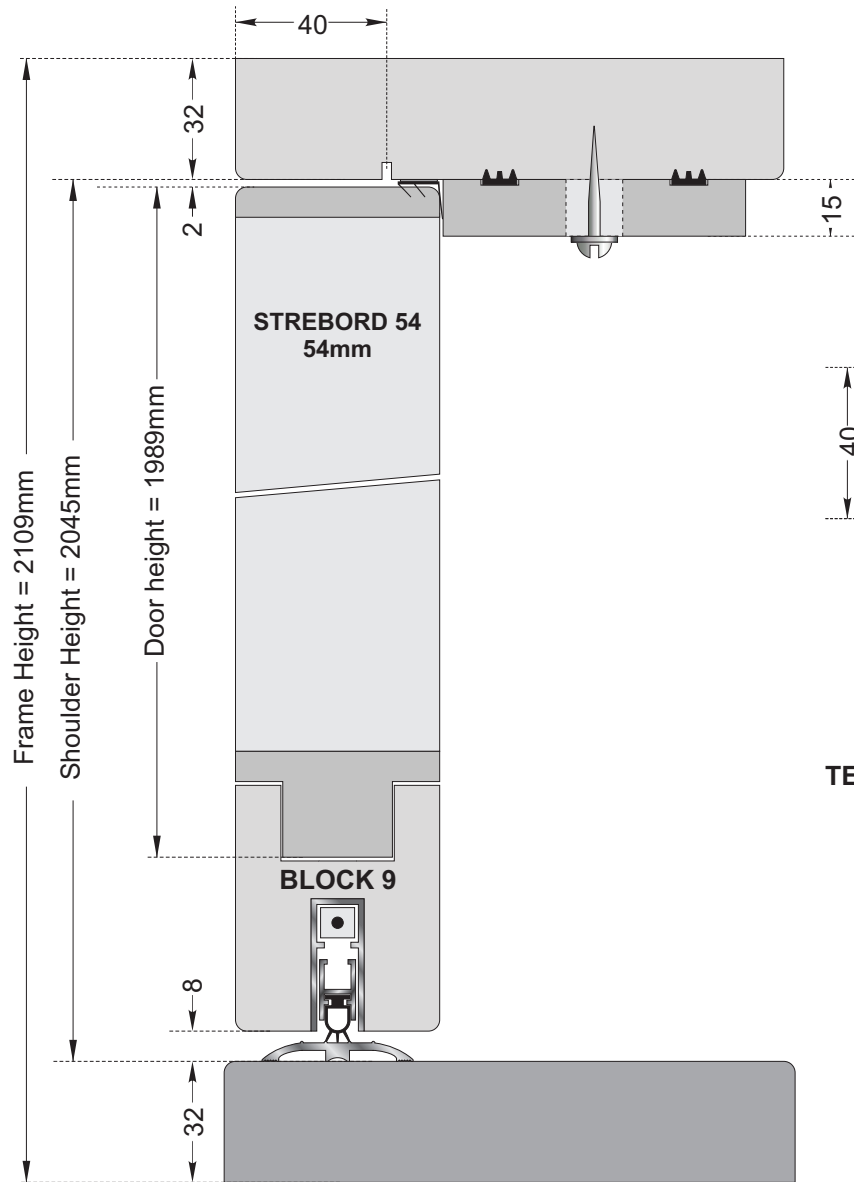

TEST 12: STREBORD 54 with NORSOUND 710 to Jambs & Head with NORSOUND 810 housed in BLOCK 9 used with NORSOUND 615 Threshold.
= Rw.31dB. SRL Test 18.

Dwg. Ref:	Sk/AHP/160208/T028		
TITLE	NORSOUND Acoustic Tests Test 12 STREBORD 54		
Scale	1 : 2	Date	16/6/08
Revisions			

Tony Palmer
Smartech 2000

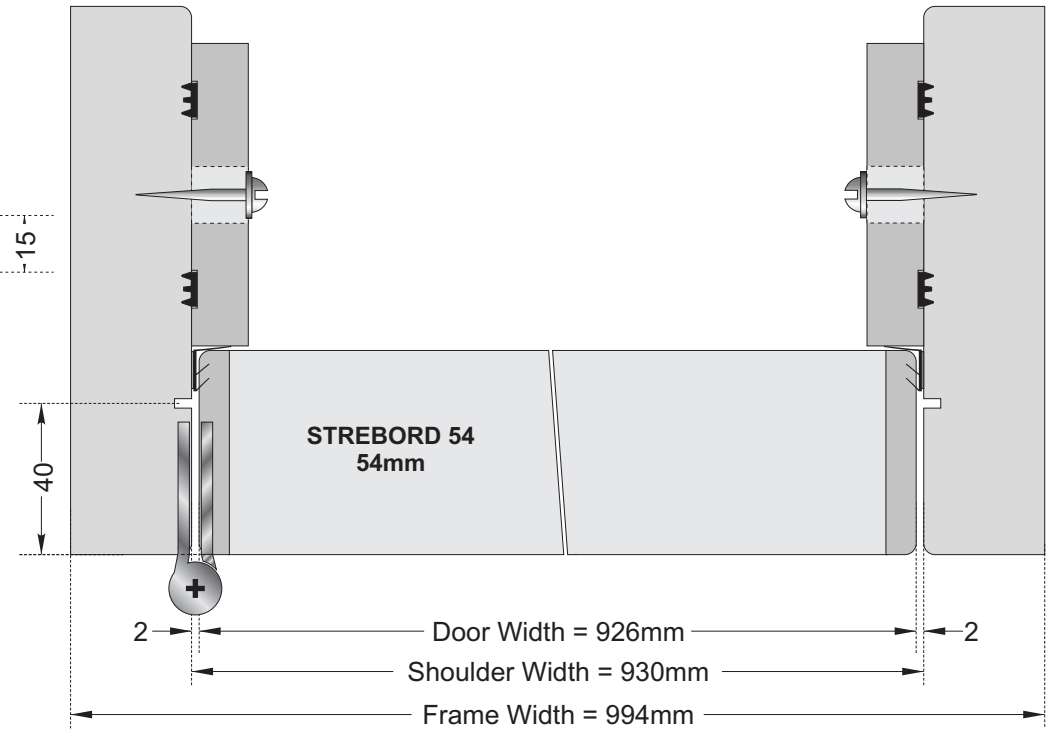
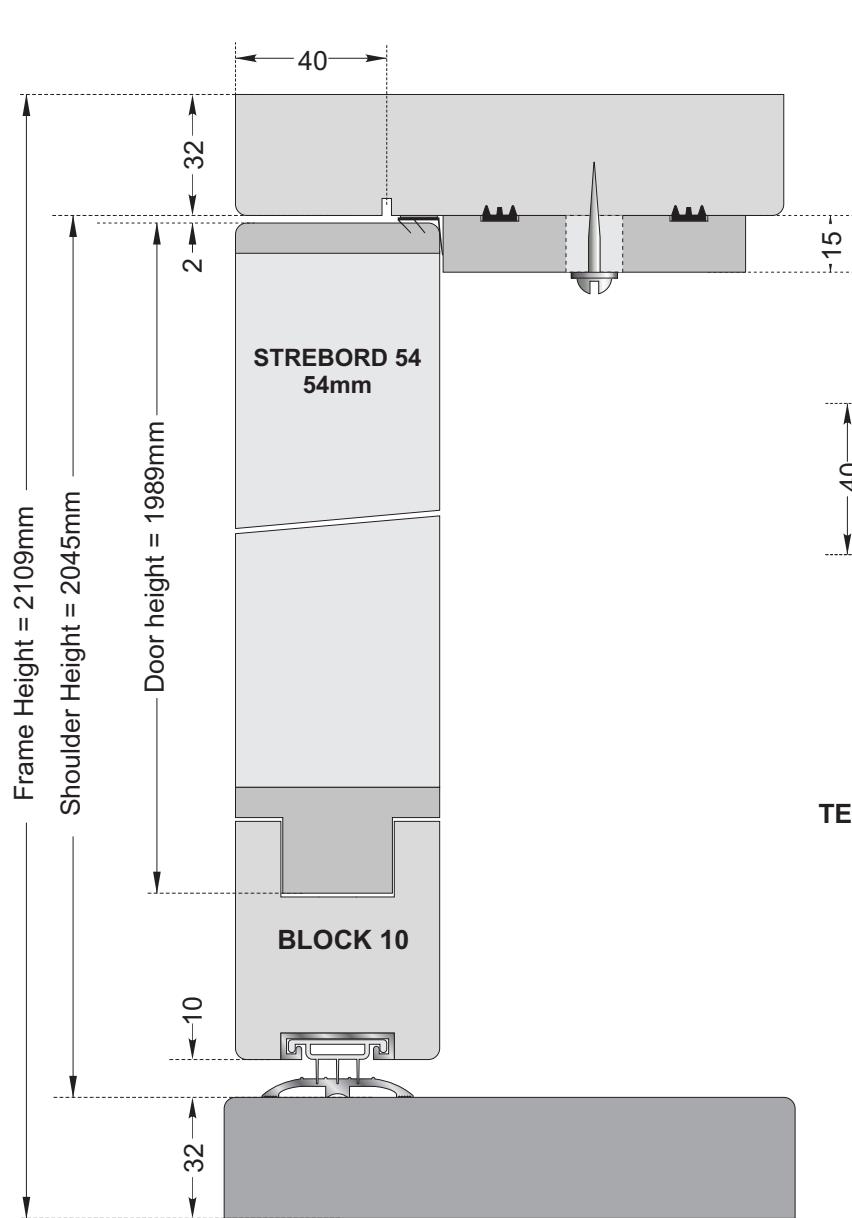

TEST 13: STREBORD 54 with NORSOUND 710 to Jambs & Head with NORSOUND 850 housed in BLOCK 10 used with NORSOUND 615 Threshold.
= Rw.31dB. SRL Test 19.

Dwg. Ref:	Sk/AHP/160208/T029		
TITLE	NORSOUND Acoustic Tests Test 13 STREBORD 54		
Scale	1 : 2	Date	16/6/08
Revisions			

Tony Palmer
Smartech 2000

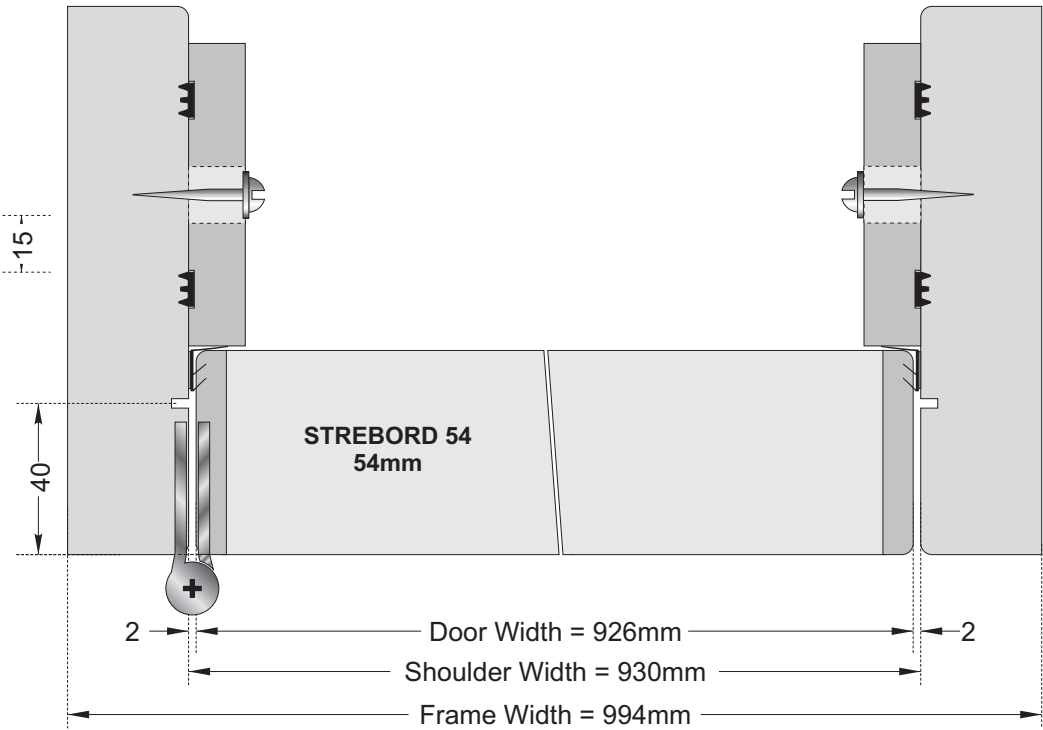
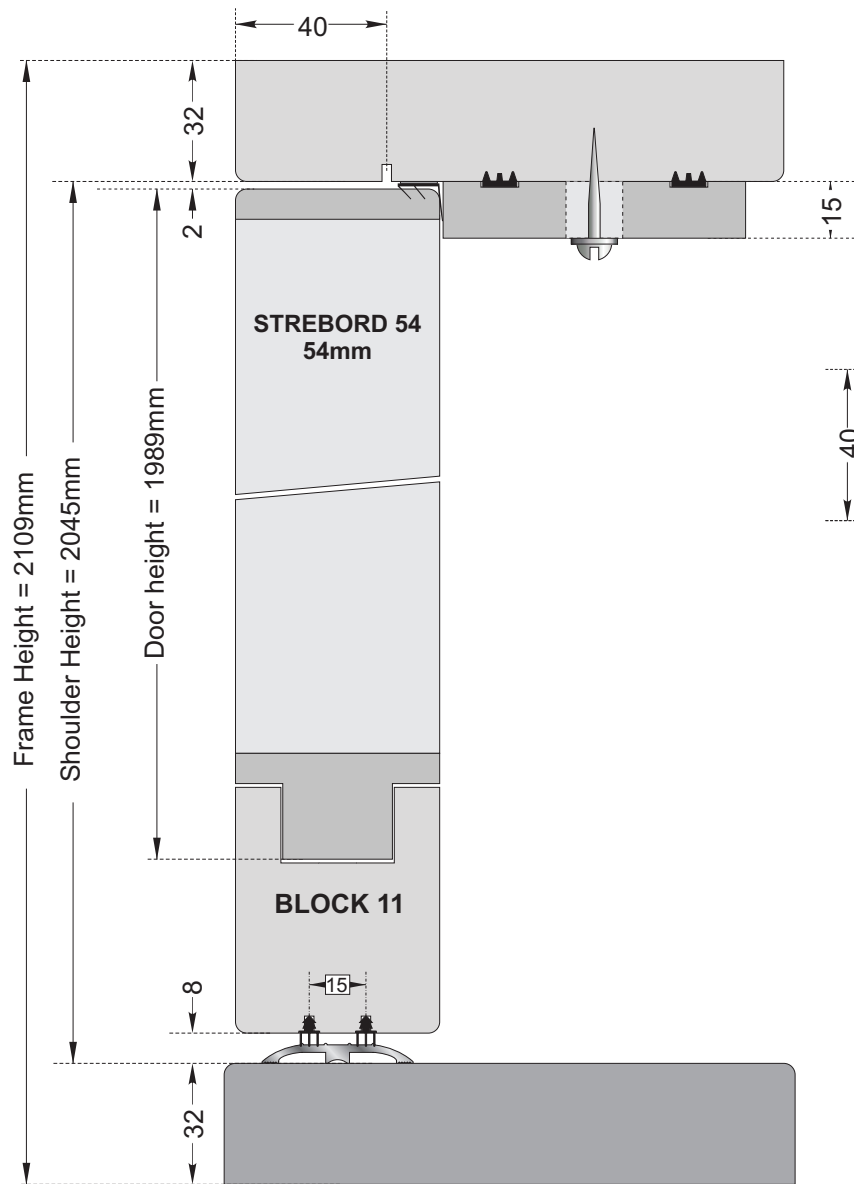

TEST 14: STREBORD 54 with NORSOUND 710 to Jamb & Head with 2 No. NORSOUND 720 housed in BLOCK 11 used with NORSOUND 615 Threshold. = **Rw.32dB. SRL Test 20.**

Dwg. Ref:	Sk/AHP/160208/T030		
TITLE	NORSOUND Acoustic Tests Test 14 STREBORD 54		
Scale	1 : 2	Date	16/6/08
Revisions			

Tony Palmer
Invented 2000

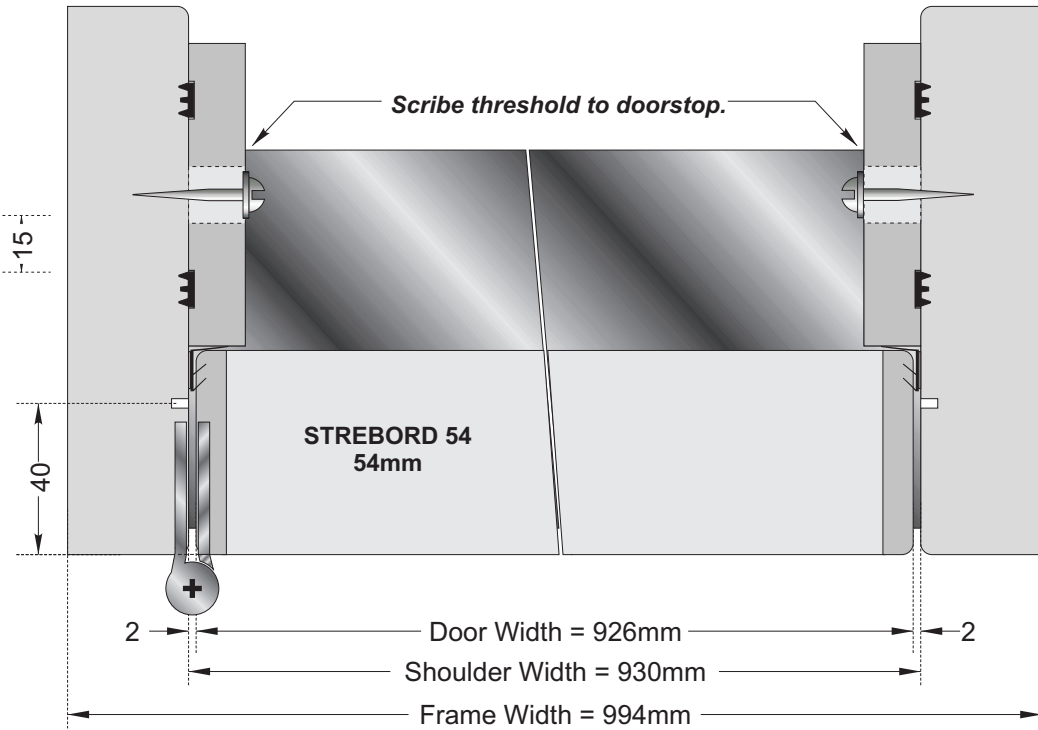
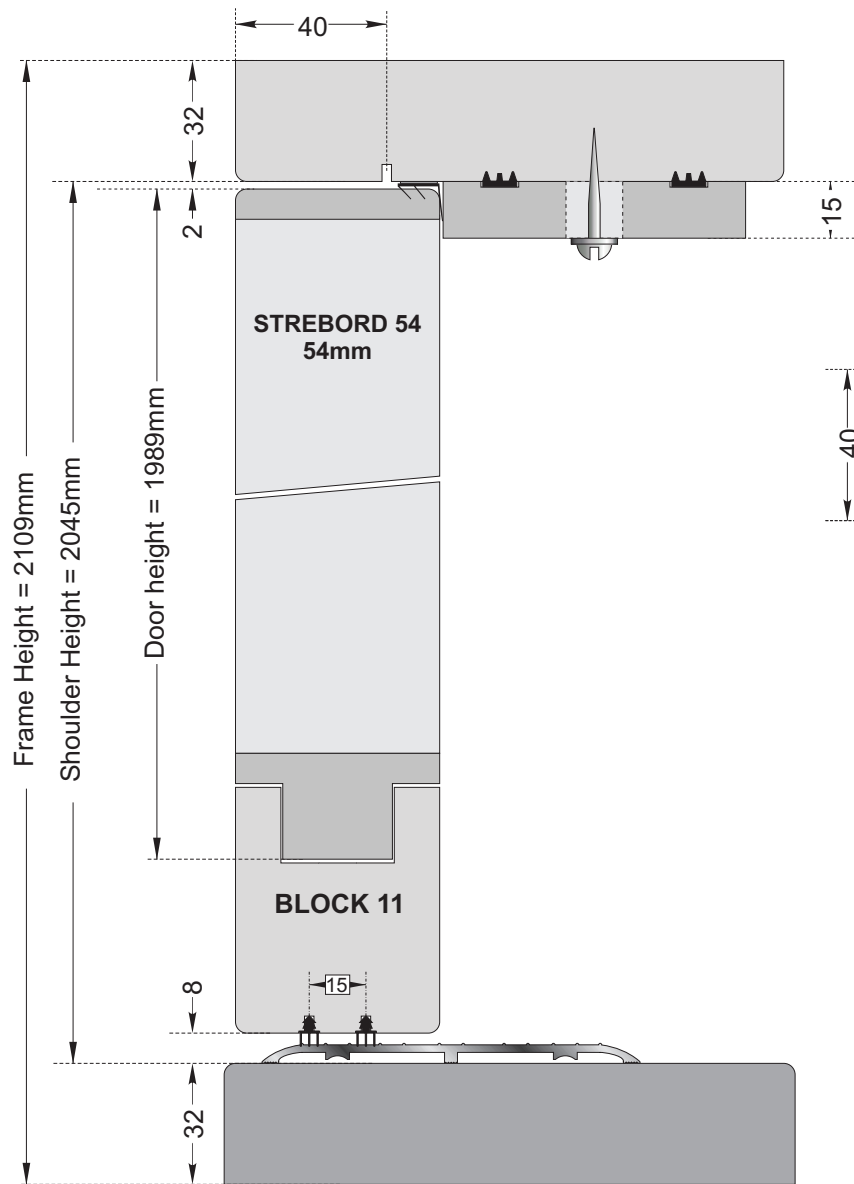

TEST 15: STREBORD 54 with NORSOUND 710 to Jamb & Head with 2 No. NORSOUND 720 housed in BLOCK 11 used with NORSOUND 620 Threshold. = **Rw.33dB. SRL Test 21.**

Test carried out at SRL request to determine influence of threshold size.

Dwg. Ref:	Sk/AHP/160208/T031		
TITLE	NORSOUND Acoustic Tests Test 15 STREBORD 54		
Scale	1 : 2	Date	16/6/08
Revisions			

Tony Palmer
Smartech 2000

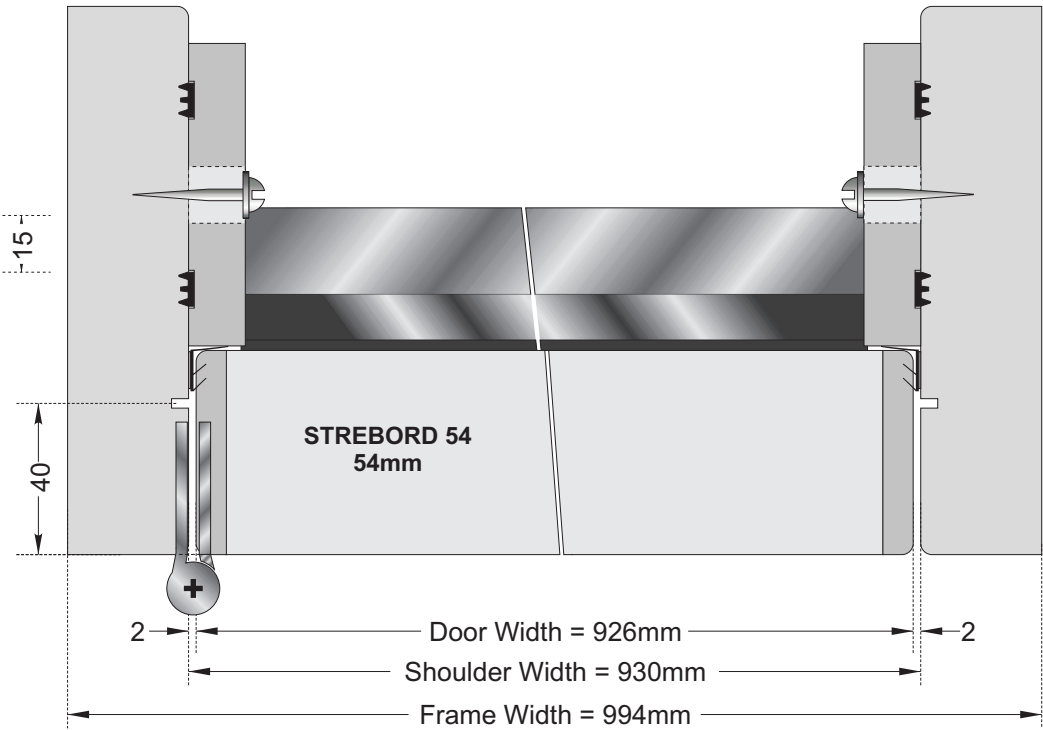
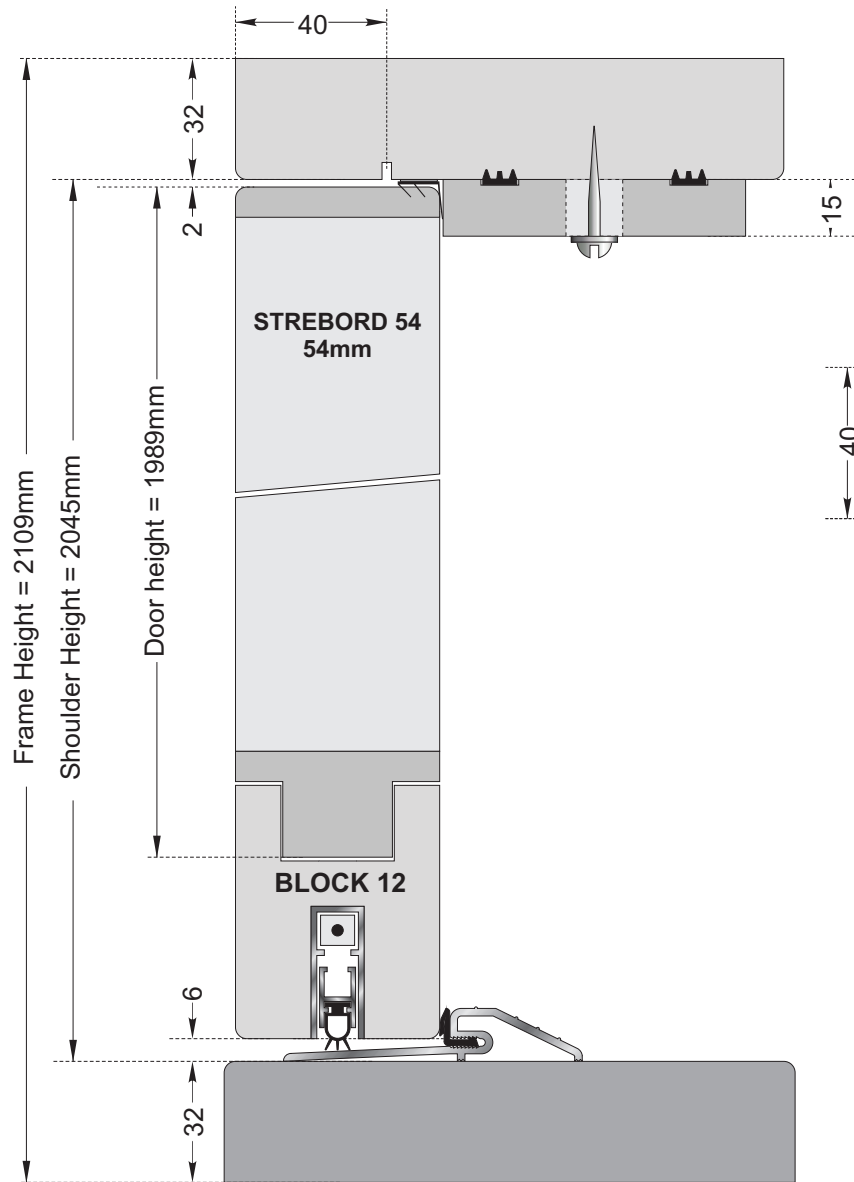

TEST 16: STREBORD 54 with NORSOUND 710 to Jamb & Head with NORSOUND 810 housed in BLOCK 12 used with NORSOUND 650 Threshold. = **Rw.33dB. SRL Test 22.**

Dwg. Ref:	Sk/AHP/160208/T032		
TITLE	NORSOUND Acoustic Tests Test 16 STREBORD 54		
Scale	1 : 2	Date	16/6/08
Revisions			

Tony Palmer
Smartech 2000

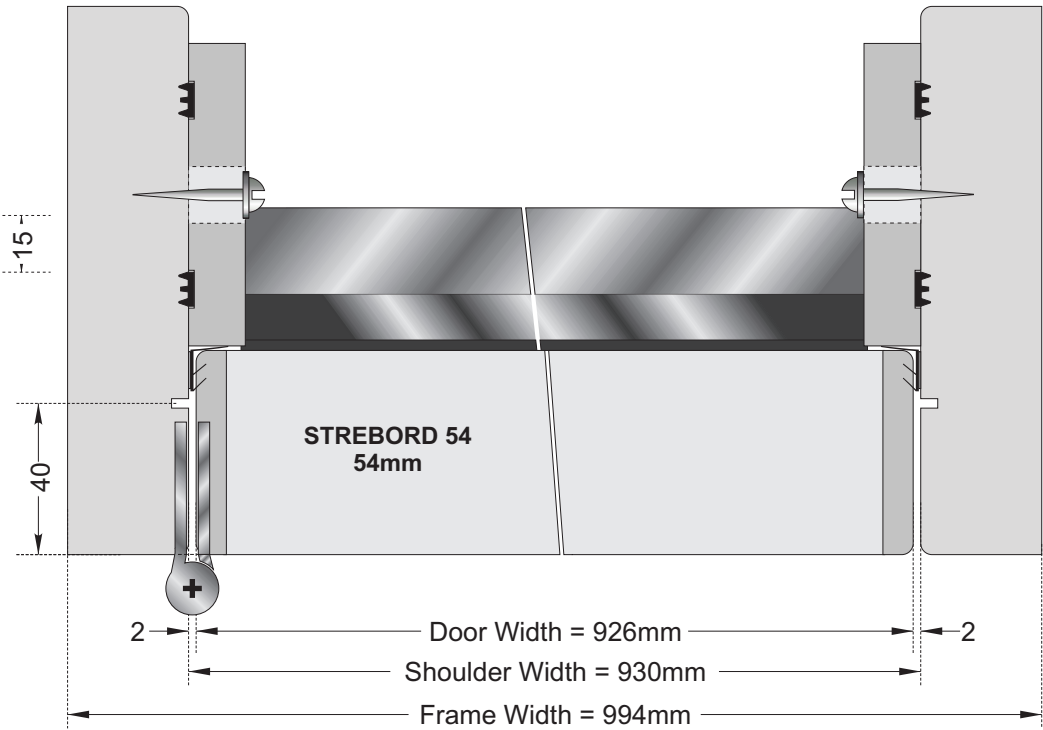
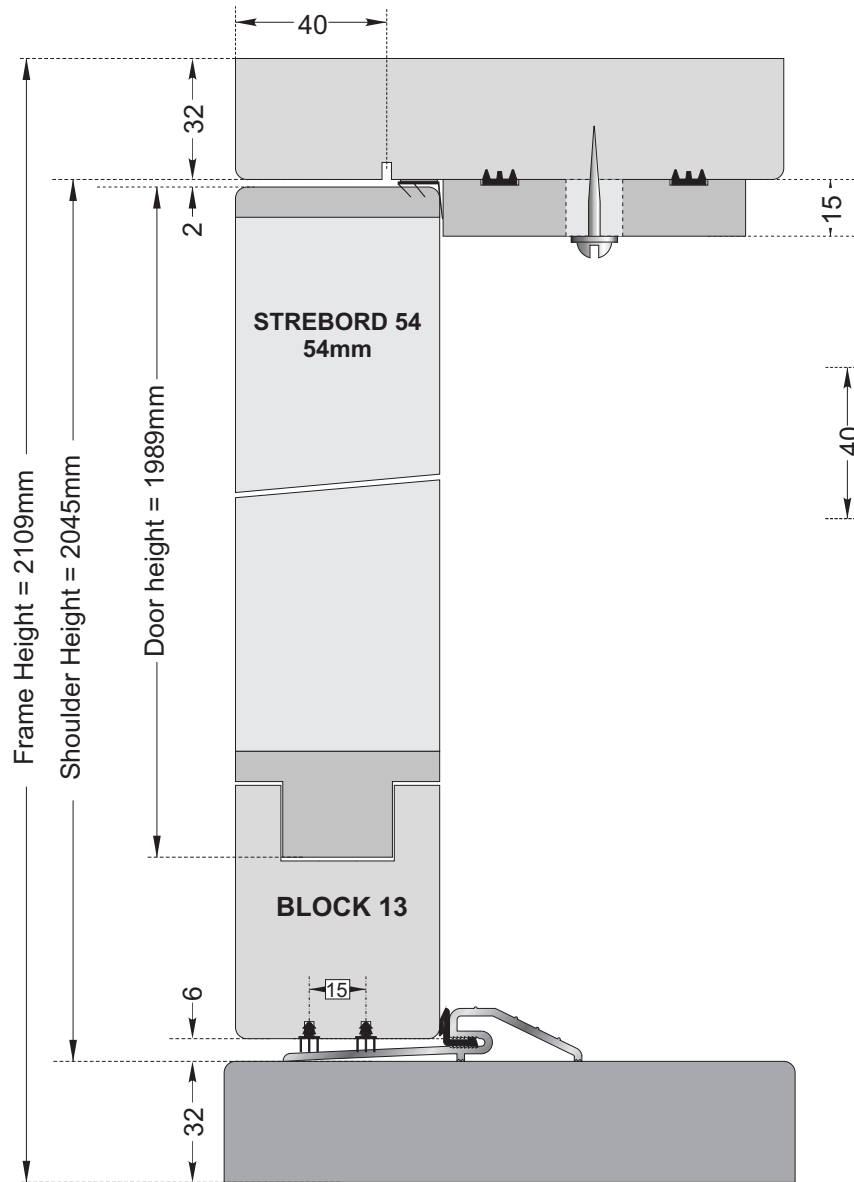

TEST 17: STREBORD 54 with NORSOUND 710 to Jamb's & Head with 2 No. NORSOUND 720 housed in BLOCK 13 used with NORSOUND 650 Threshold. = **Rw.33dB. SRL Test 23.**

Dwg. Ref:	Sk/AHP/160208/T033		
TITLE	NORSOUND Acoustic Tests Test 17 STREBORD 54		
Scale	1 : 2	Date	16/6/08
Revisions			

Tony Palmer
Invented 2000

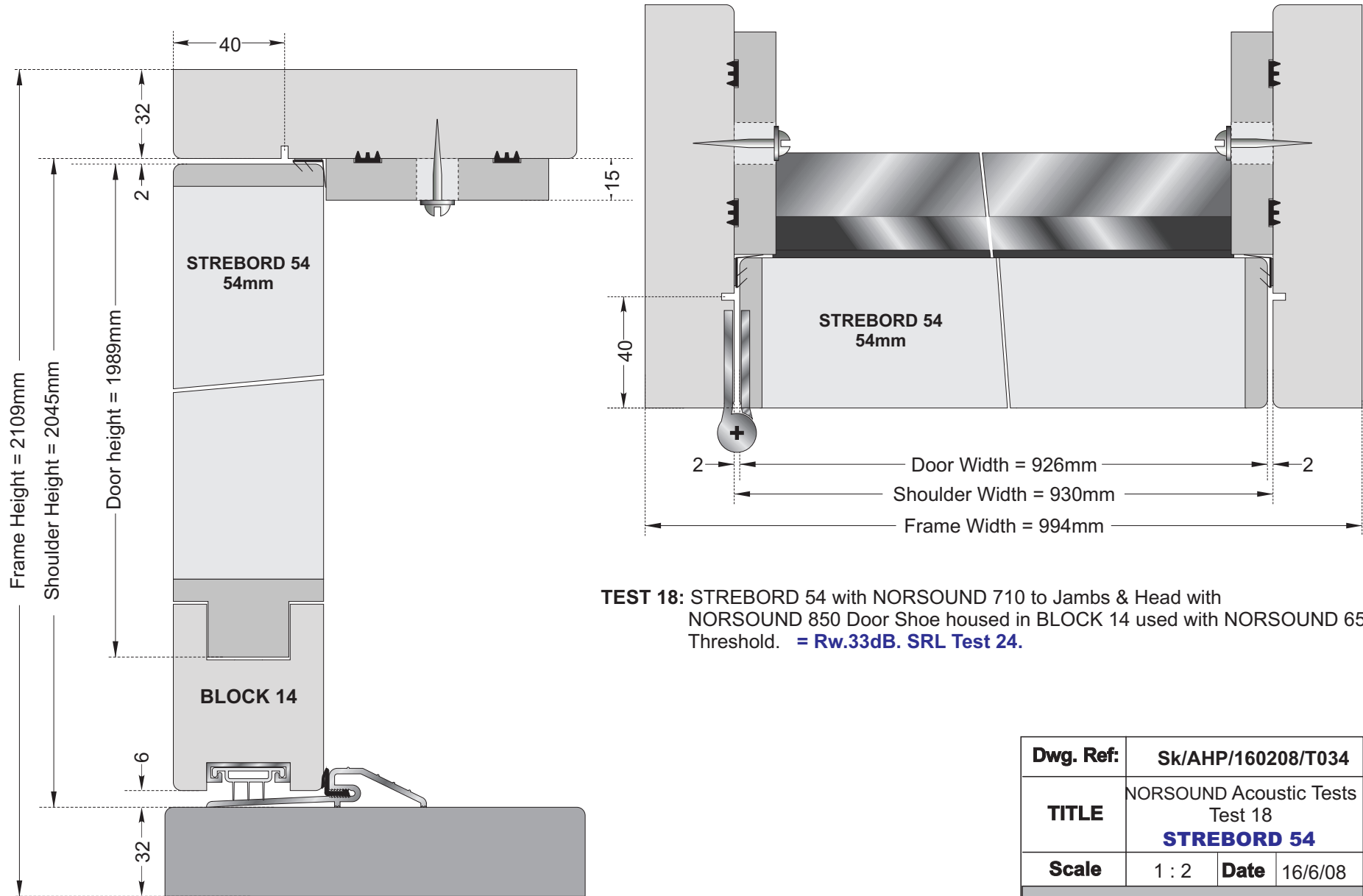

TEST 18: STREBORD 54 with NORSOUND 710 to Jambs & Head with NORSOUND 850 Door Shoe housed in BLOCK 14 used with NORSOUND 650 Threshold. = **Rw.33dB. SRL Test 24.**

Dwg. Ref:	Sk/AHP/160208/T034		
TITLE	NORSOUND Acoustic Tests Test 18 STREBORD 54		
Scale	1 : 2	Date	16/6/08
Revisions			

Tony Palmer
Smartech 2000

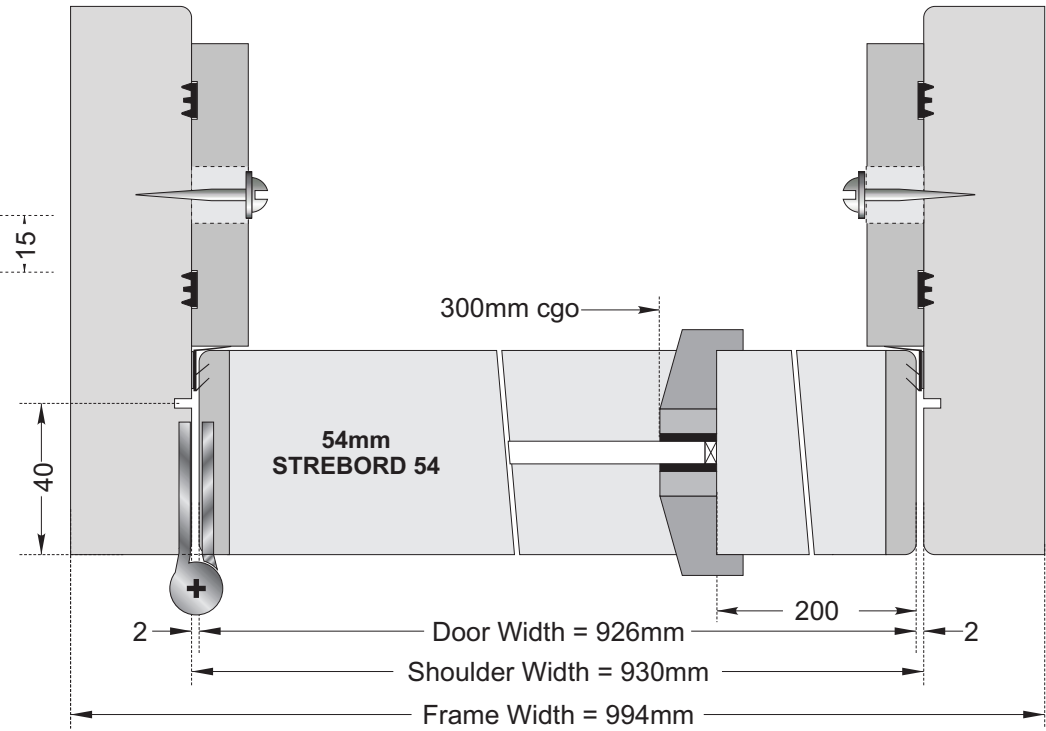
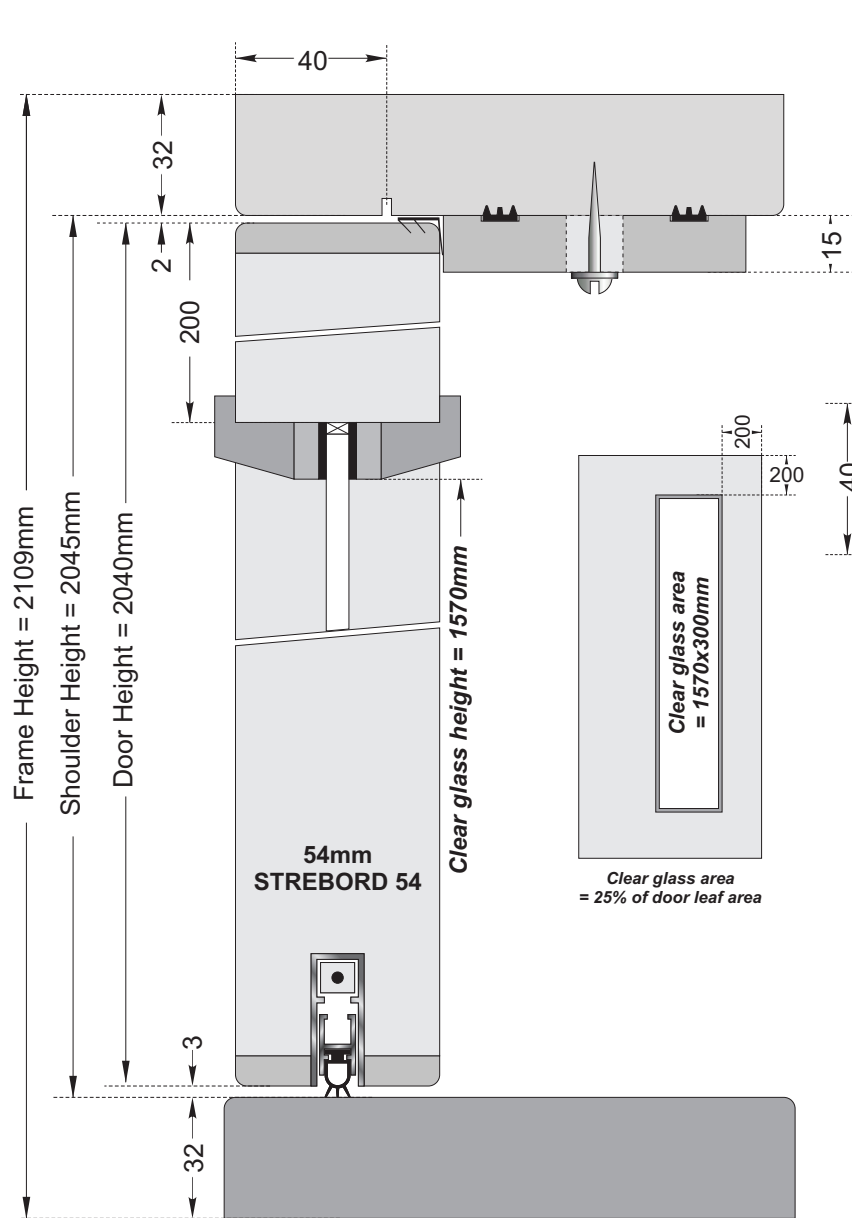

TEST 60: Nom. 6mm Pyroshield glass. NORSOUND 710 to Head & Jamb.
NORSOUND 810 to Threshold. = **Rw.34dB. SRL Test 30**

Dwg. Ref:	Sk/AHP/160208/T035		
TITLE	NORSOUND Acoustic Tests Test 60 STREBORD 54		
Scale	1 : 2	Date	16/6/08
Revisions			

Tony Palmer
Invented 2000

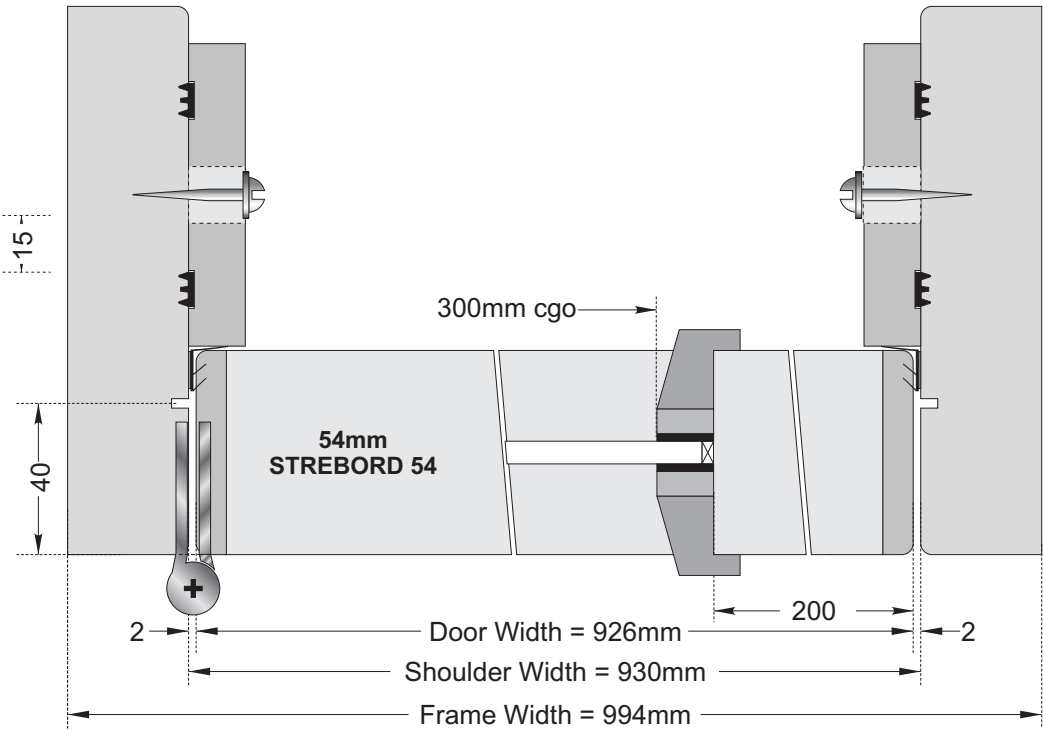
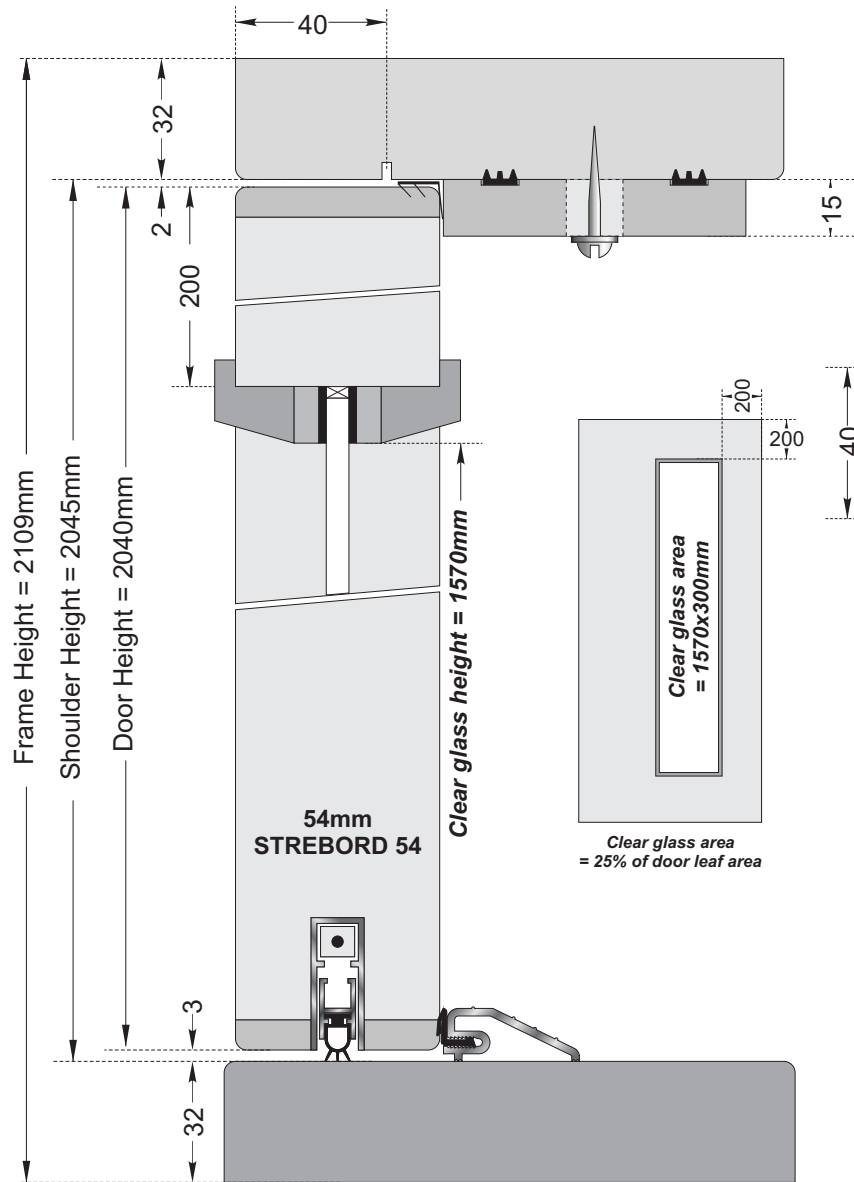

TEST 60a: Nom. 6mm Pyroshield glass. NORSOUND 710 to Head & Jamb.
NORSOUND 810 used with modified NORSOUND 650 Threshold.
= Rw.34dB. SRL Test 31.

TEST 60b: Nom. 6mm Pyroshield glass. NOROSOUND 710 to Head & Jamb.
NORSOUND 810 used with modified NORSOUND 650 Threshold.
= Rw.35dB. SRL Test 32.

Dwg. Ref:	Sk/AHP/160208/T036		
TITLE	NORSOUND Acoustic Tests Test 60a & 60b STREBORD 54		
Scale	1 : 2	Date	16/6/08
Revisions			

Tony Palmer
Smartech 2000

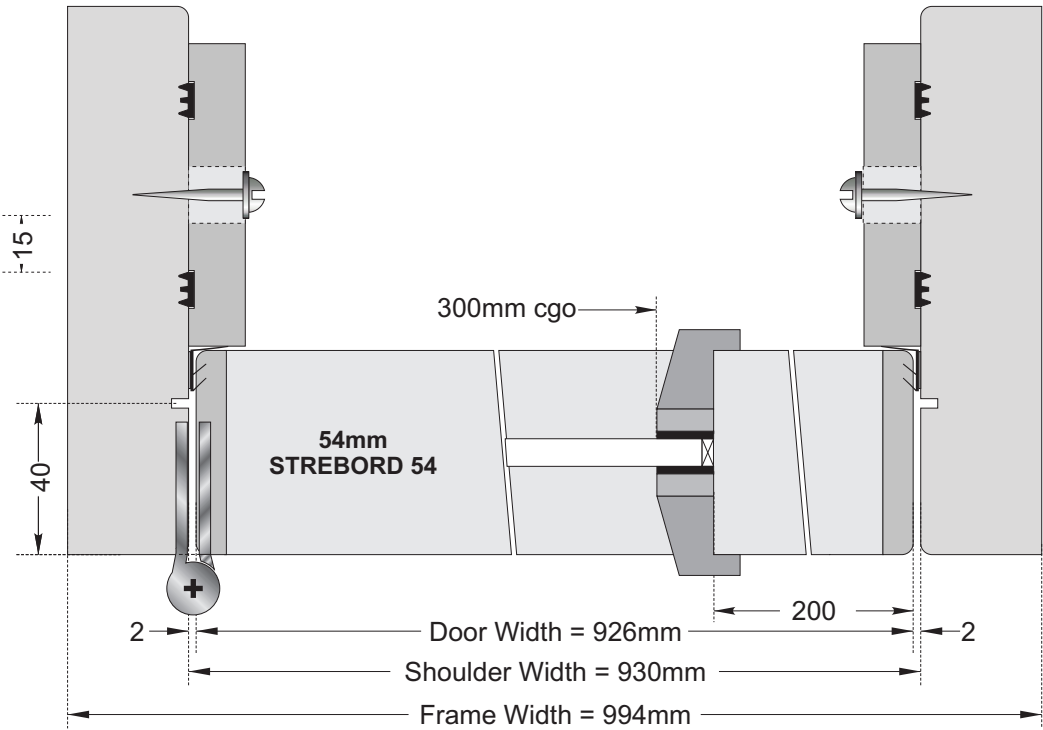
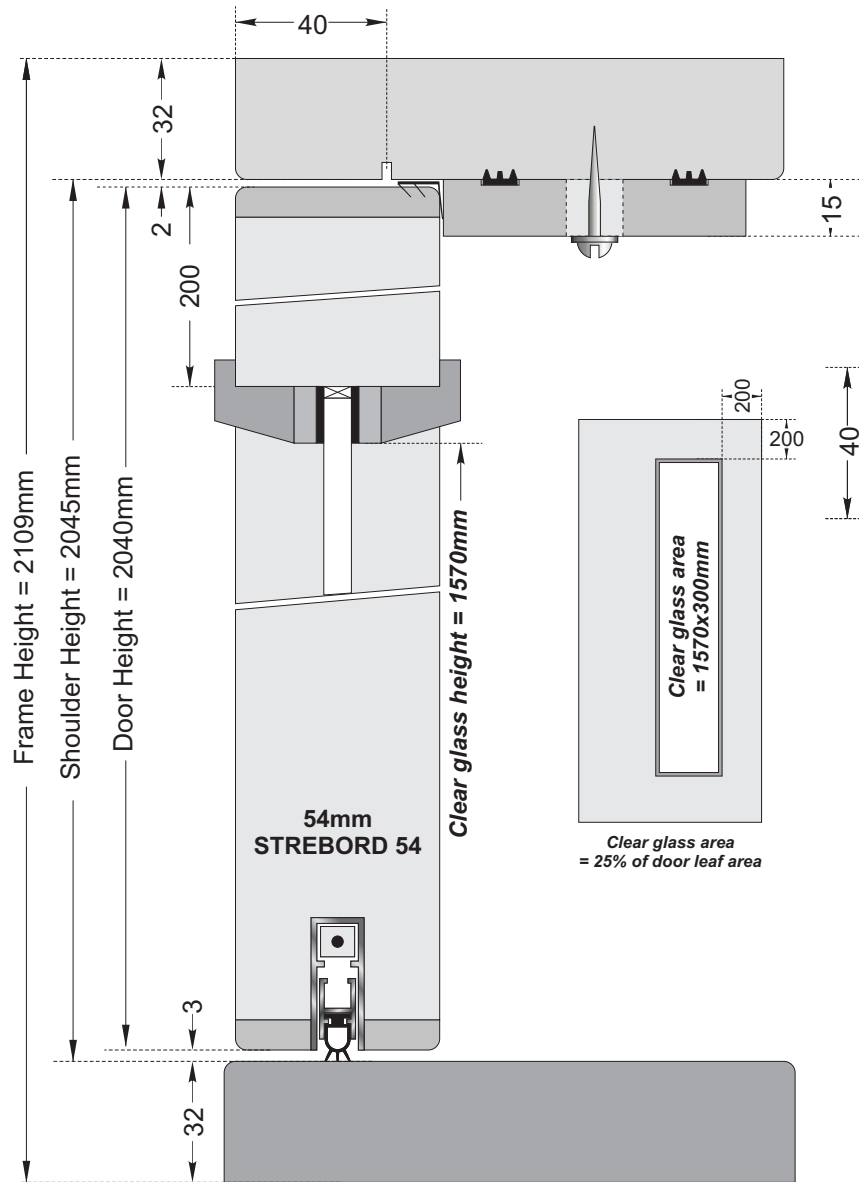

TEST 60c : Nom. 7mm Pyrobelite glass. NORSOUND 710 to Head & Jamb.
NORSOUND 810 to Threshold. = **Rw.35dB. SRL Test 42.**

Dwg. Ref:	Sk/AHP/160208/T037		
TITLE	NORSOUND Acoustic Tests Test 60c STREBORD 54		
Scale	1 : 2	Date	16/6/08
Revisions			

Tony Palmer
Inventor 2000

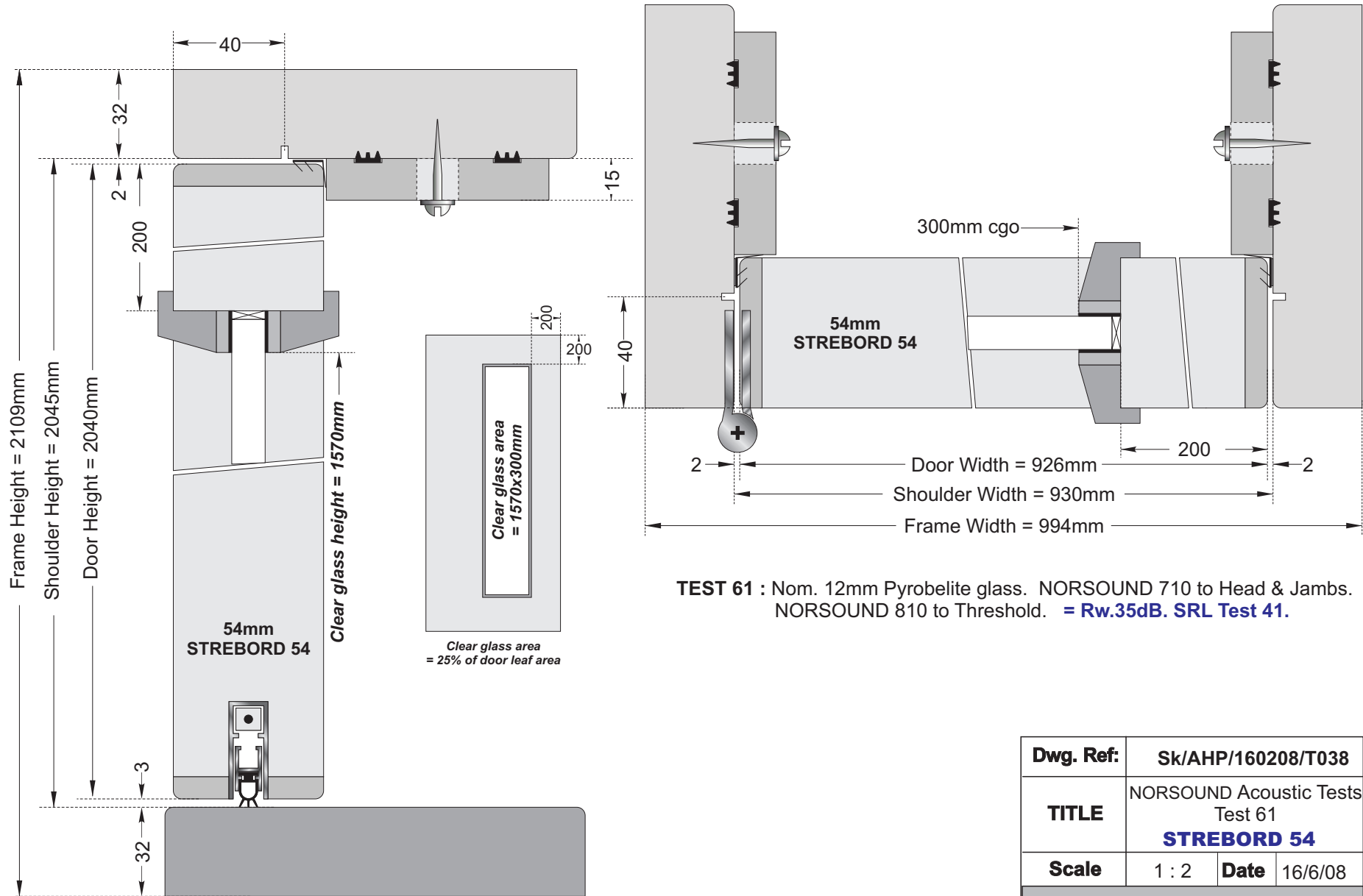

Dwg. Ref:	Sk/AHP/160208/T038		
TITLE	NORSOUND Acoustic Tests Test 61 STREBORD 54		
Scale	1 : 2	Date	16/6/08
Revisions			

Tony Palmer
Inventor 2000

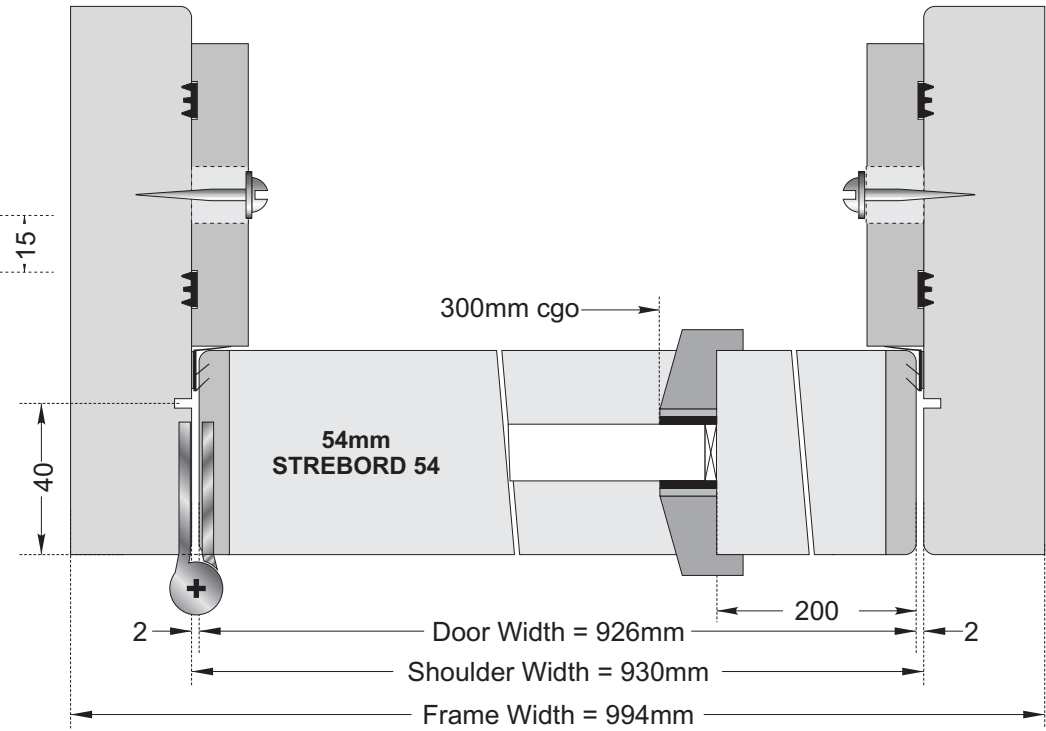
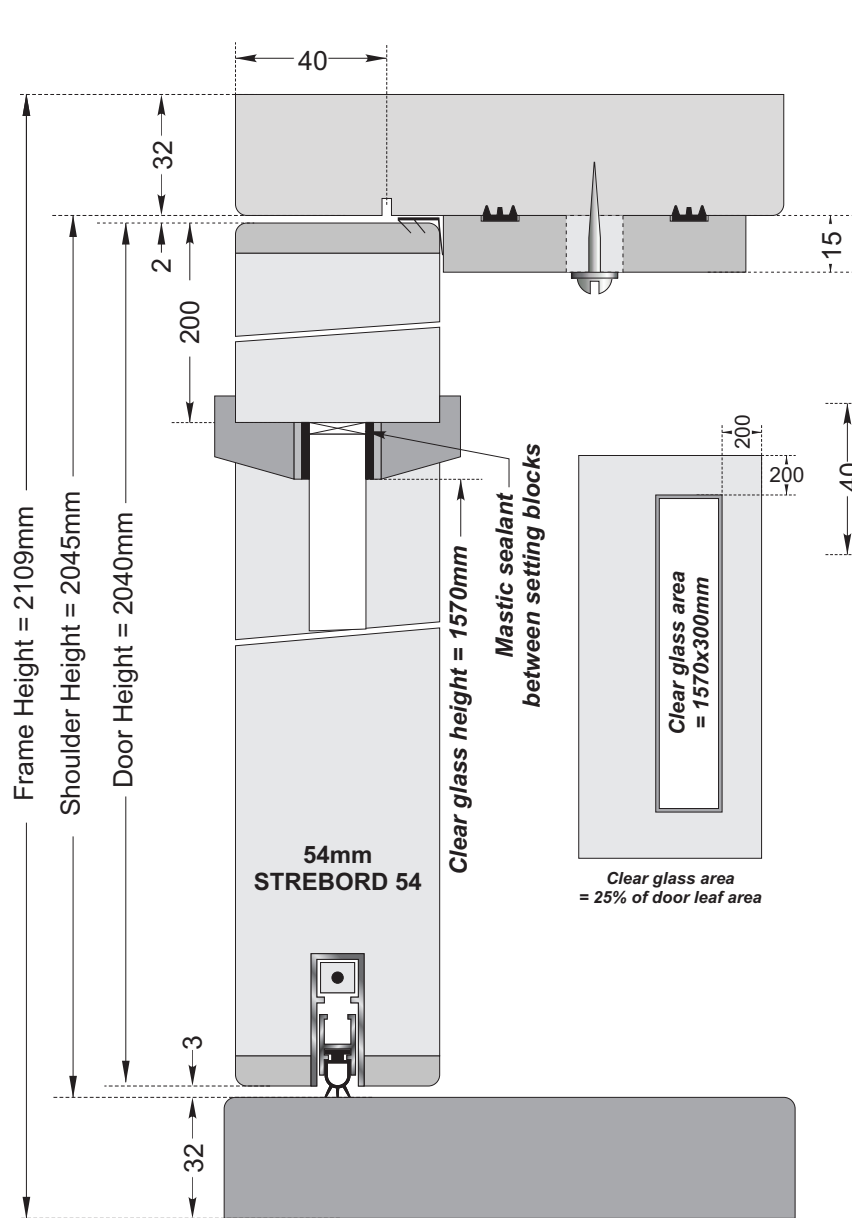

TEST 63a : Nom. 16mm Pyrobel glass. NORSOUND 710 to Head & Jambs.
NORSOUND 810 to Threshold. = **Rw.35dB. SRL Test 37.**

Dwg. Ref:	Sk/AHP/160208/T039		
TITLE	NORSOUND Acoustic Tests Test 63a STREBORD 54		
Scale	1 : 2	Date	16/6/08
Revisions			

Tony Palmer
Inventor 2000

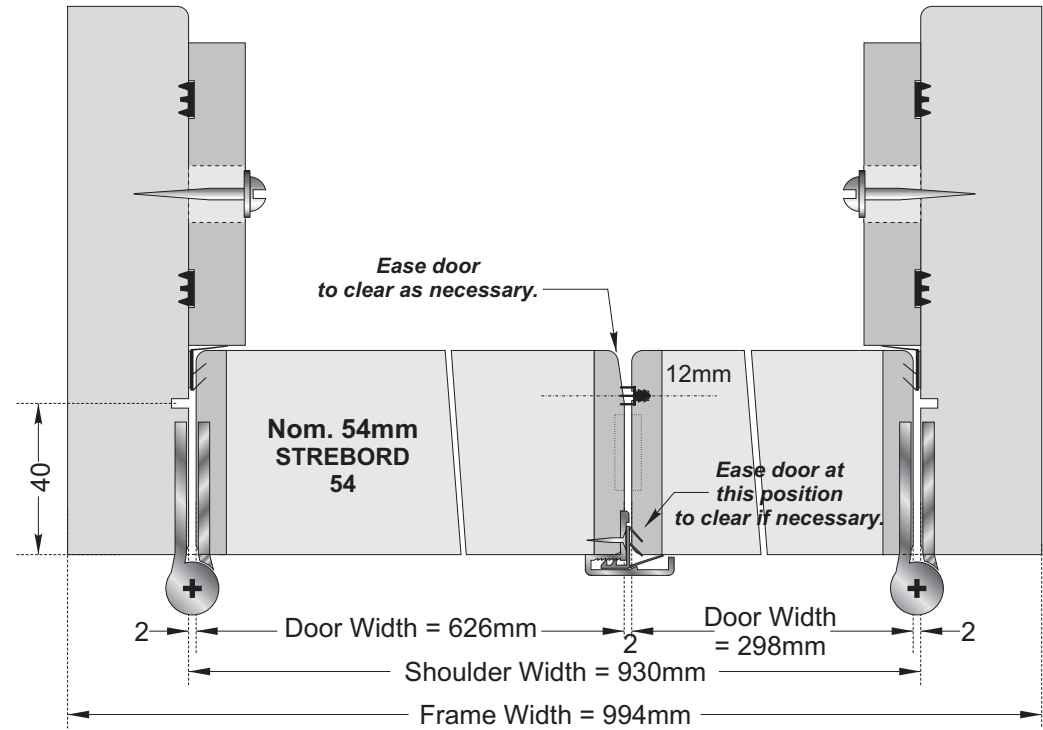
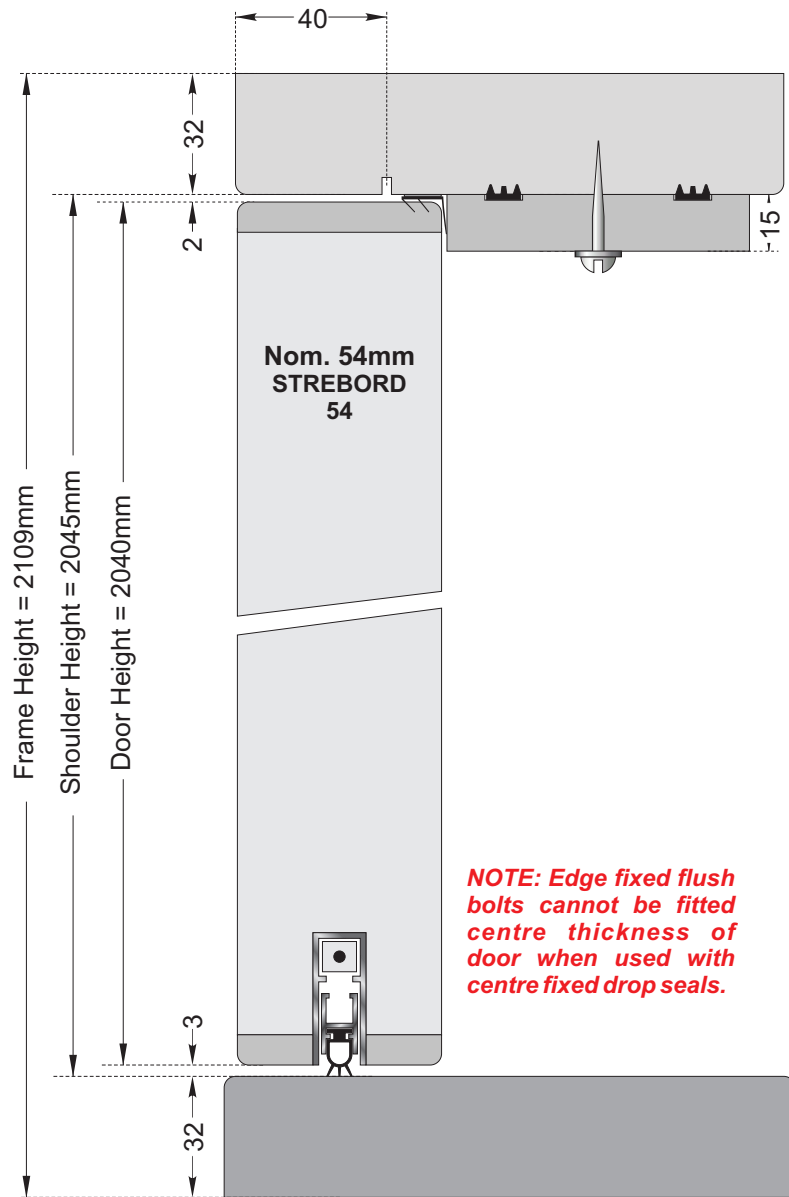

TEST 80: NORSOUND 710 to Head & Jambs + NORSOUND 810 to threshold of each door.
NORSOUND 720 and NORSOUND 510 at Meeting Stiles.
= Rw.33dB. SRL Test 86.

Dwg. Ref:	Sk/AHP/160208/T040		
TITLE	NORSOUND Acoustic Tests Test 80 STREBORD 54		
Scale	1 : 2	Date	16/6/08
Revisions			

Tony Palmer
Inventor 2000

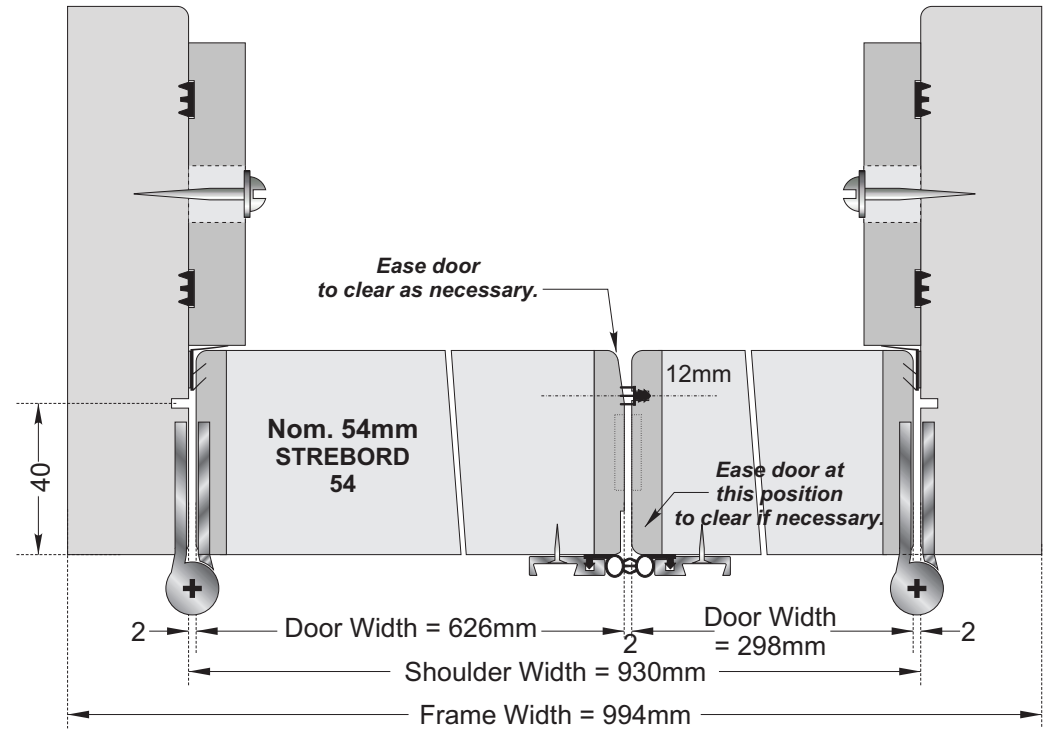
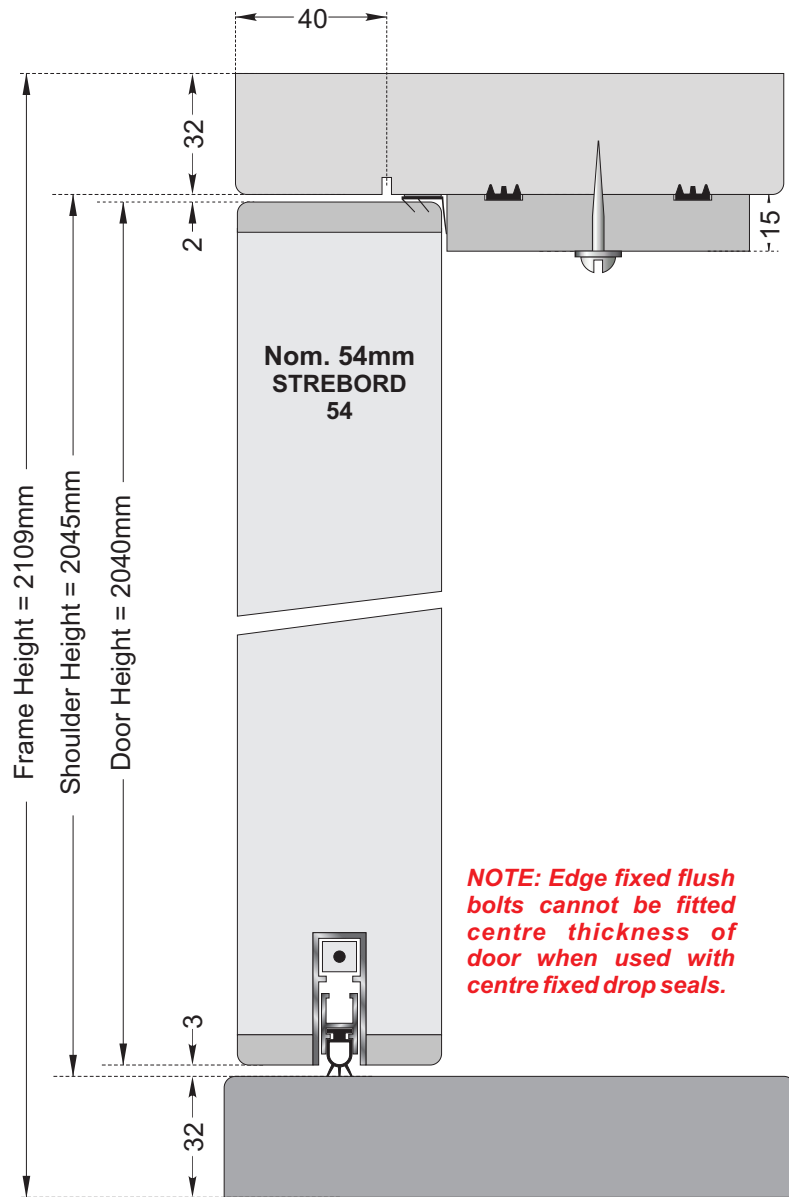

TEST 81: NORSOUND 710 to Head & Jambs + NORSOUND 810 to threshold of each door.
NORSOUND 720 and 2No. NORSOUND 755 at Meeting Stiles.
= Rw.33dB. SRL Test 88.

Dwg. Ref:	Sk/AHP/160208/T041		
TITLE	NORSOUND Acoustic Tests Test 81 STREBORD 54		
Scale	1 : 2	Date	16/6/08
Revisions			

Tony Palmer
Invented 2000

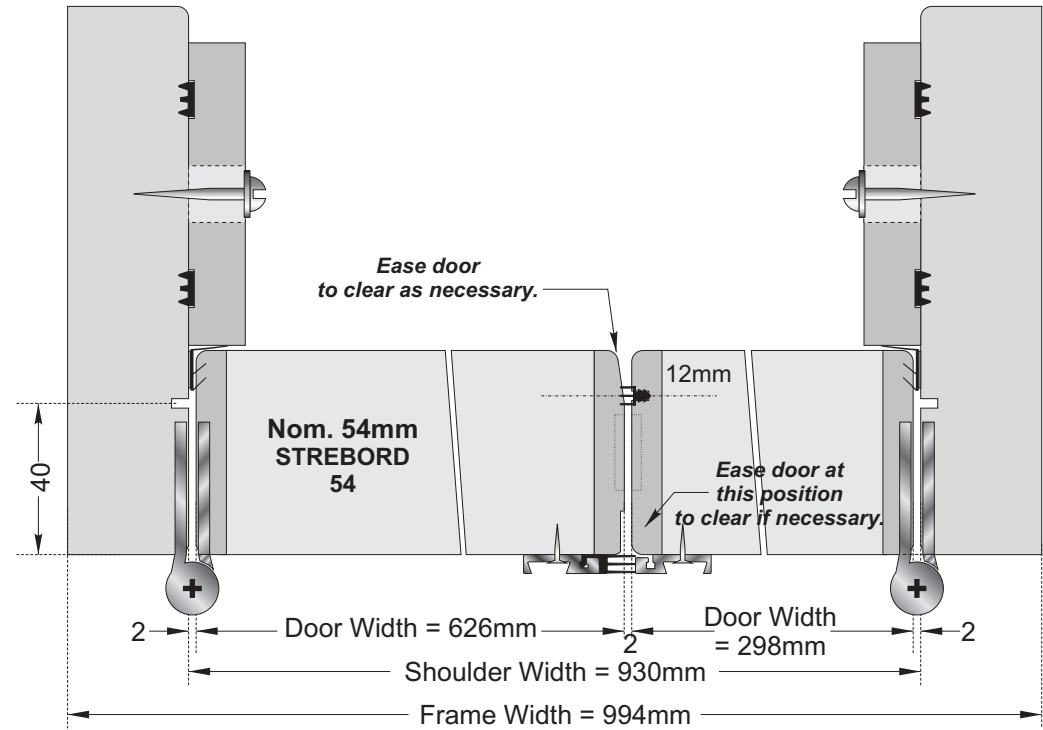
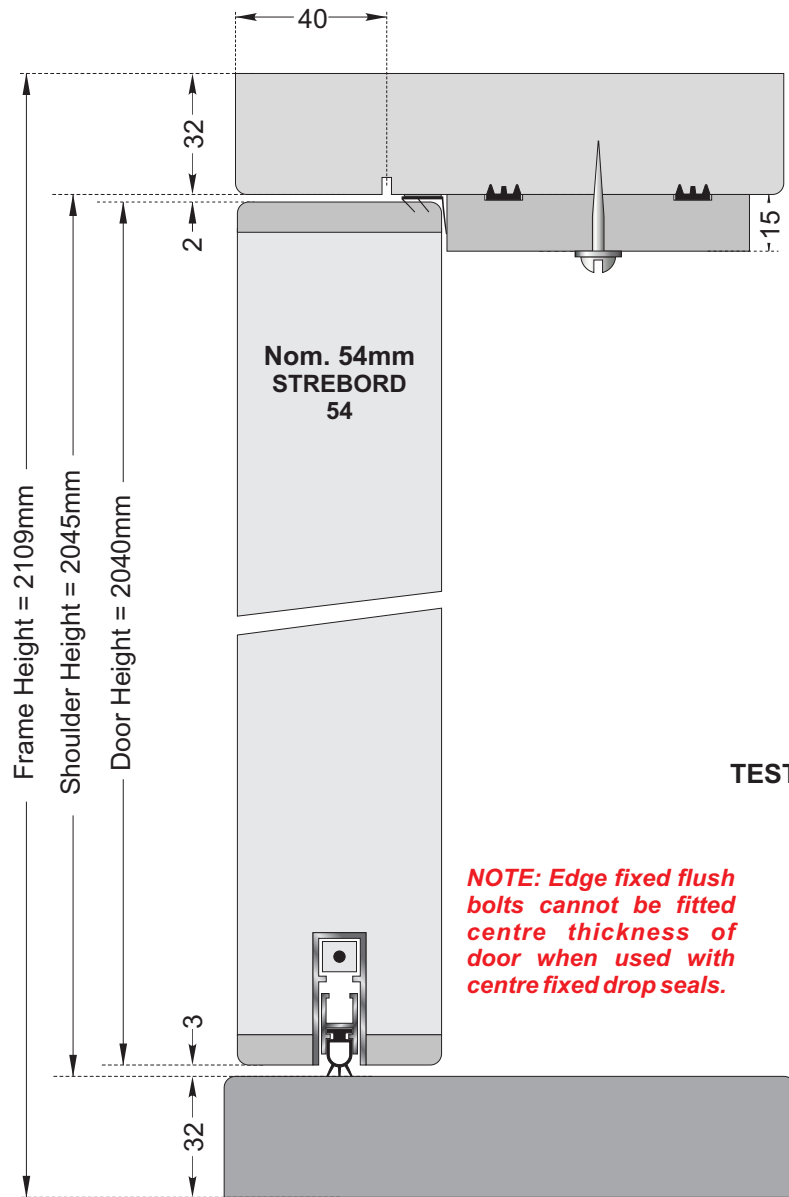

TEST 82: NORSOUND 710 to Head & Jambs + NORSOUND 810 to threshold of each door.
NORSOUND 855 + NORSOUND 855 Carrier only + NORSOUND 720 at Meeting Stiles.
= Rw.33dB. SRL Test 87.

Dwg. Ref:	Sk/AHP/160208/T042		
TITLE	NORSOUND Acoustic Tests Test 82 STREBORD 54		
Scale	1 : 2	Date	16/6/08
Revisions			

Tony Palmer
Invented 2000

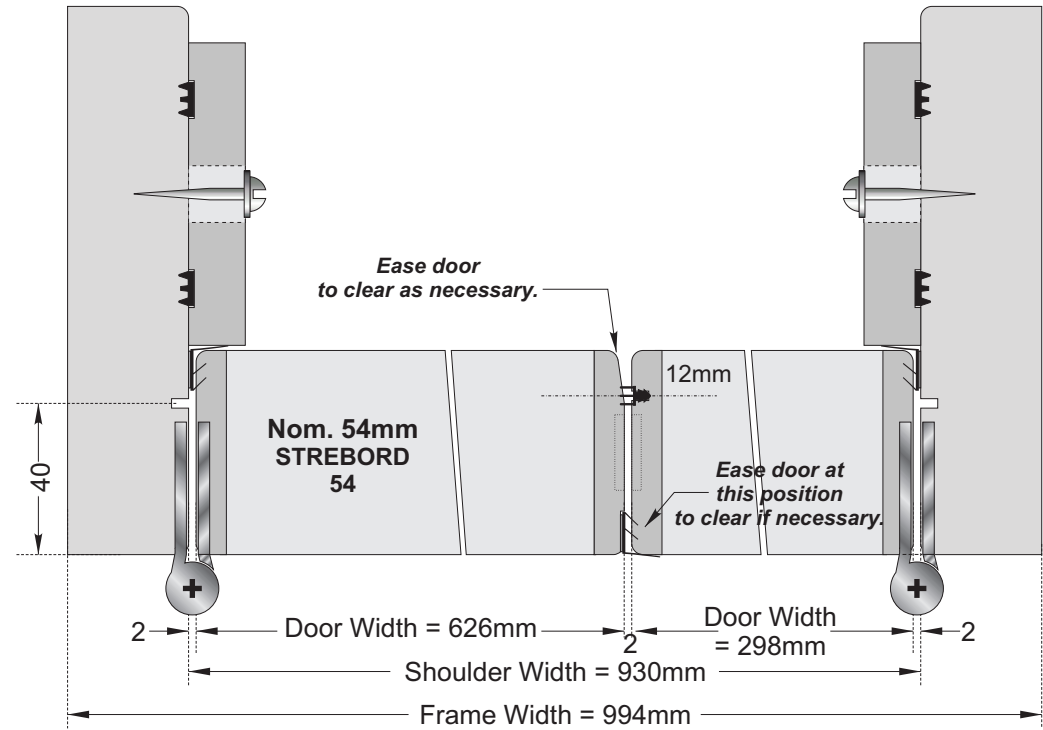
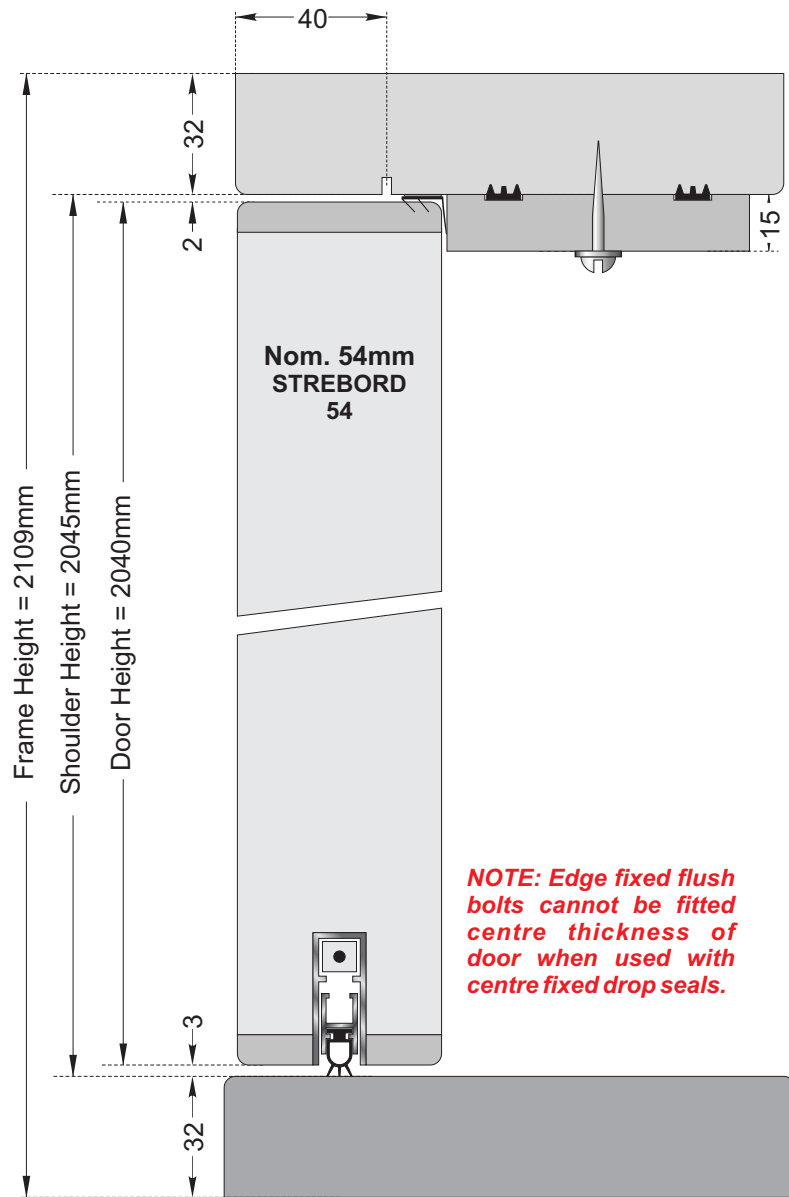

TEST 83: NORSOUND 710 to Head & Jambs + NORSOUND 810 to threshold of each door.
NORSOUND 710 + NORSOUND 720 at Meeting Stiles.
= **Rw.32dB. SRL Test 89.**

Dwg. Ref:	Sk/AHP/160208/T043		
TITLE	NORSOUND Acoustic Tests Test 83 STREBORD 54		
Scale	1 : 2	Date	16/6/08
Revisions			

Tony Palmer
Invented 2000

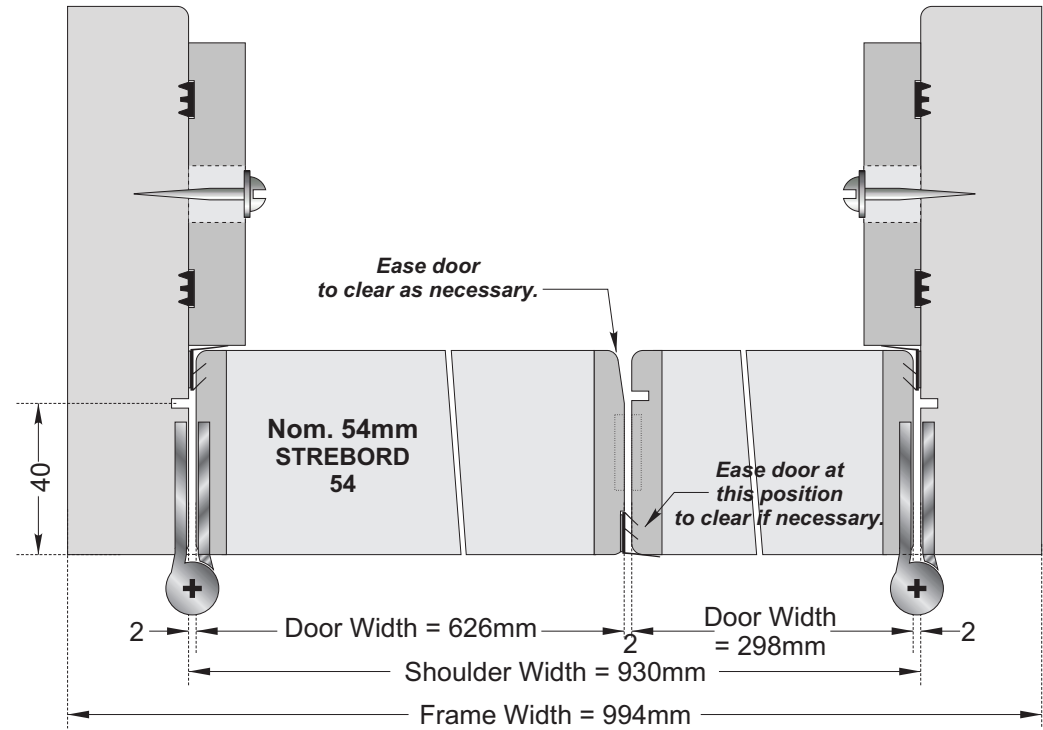
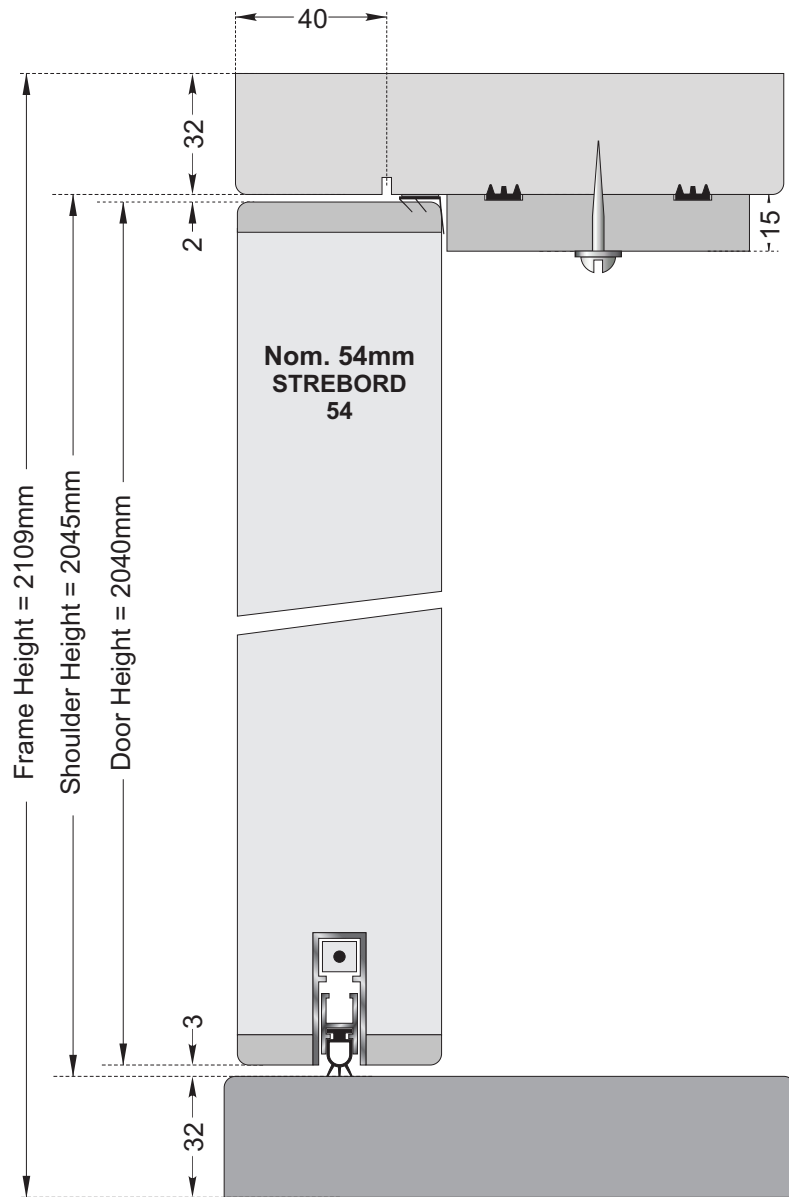

TEST 87: NORSOUND 710 to Head & Jambs + NORSOUND 810 to threshold of each door. NORSOUND 710 at Meeting Stiles. = **Rw.31dB. SRL Test 90.**

TEST 87a: Fully caulked test Strebord 54 unequal pair. = **Rw.34dB. SRL Test 91.**

NOTE: Edge fixed flush bolts cannot be fitted centre thickness of door when used with centre fixed drop seals.

Dwg. Ref:	Sk/AHP/160208/T044		
TITLE	NORSOUND Acoustic Tests Test 87 & 87a STREBORD 54		
Scale	1 : 2	Date	16/6/08
Revisions			

Tony Palmer
Invented 2000

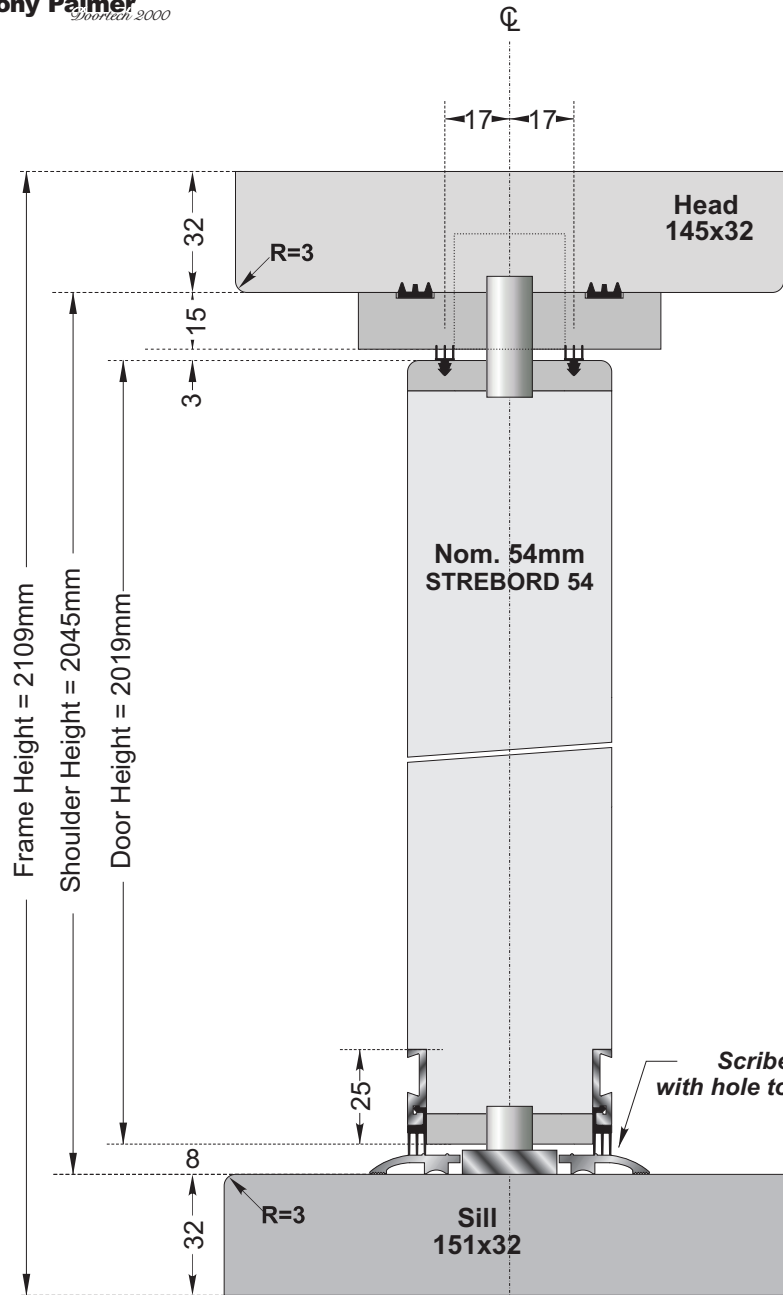

NOTE: At saddle scallop, scribe threshold to suit OR use filler to fill gap.

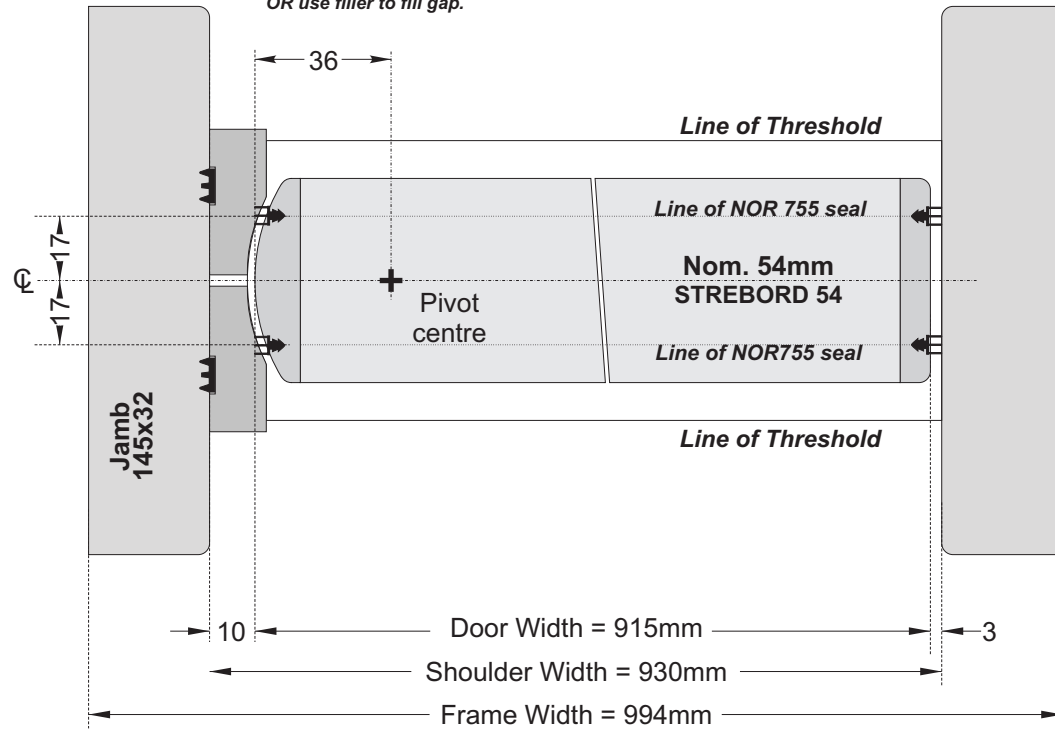

TEST 99: Fully Caulked Double Action. = **Rw.33dB. SRL Test 107.**

TEST 100: Twin row NORSOUND 720 to Jamb & Head. Twin NORSOUND 855 seals recessed into face at the bottom of the door used with NORSOUND 620 Threshold plate scribed to suit R&T 36mm centre pivot fixings = **Rw.32dB. SRL Test 109.**

Dwg. Ref:	Sk/AHP/160208/T045		
TITLE	NORSOUND Acoustic Tests Test 99 & 100 STREBORD 54		
Scale	1 : 2	Date	16/6/08
Revisions			

Tony Palmer
Invented 2000

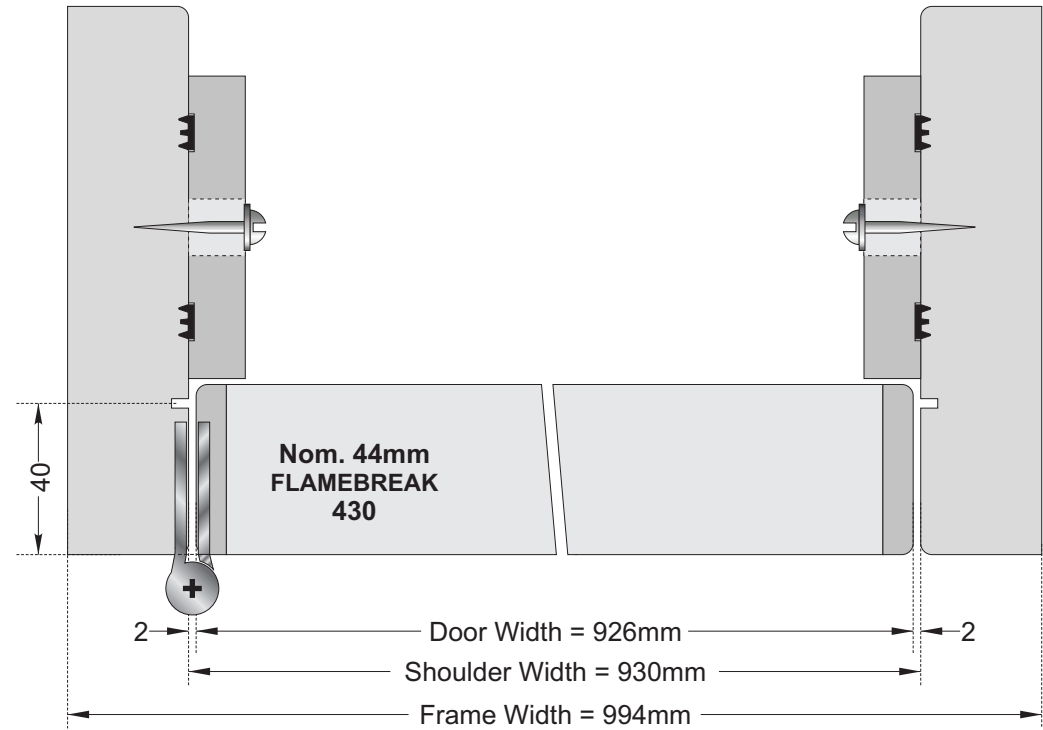
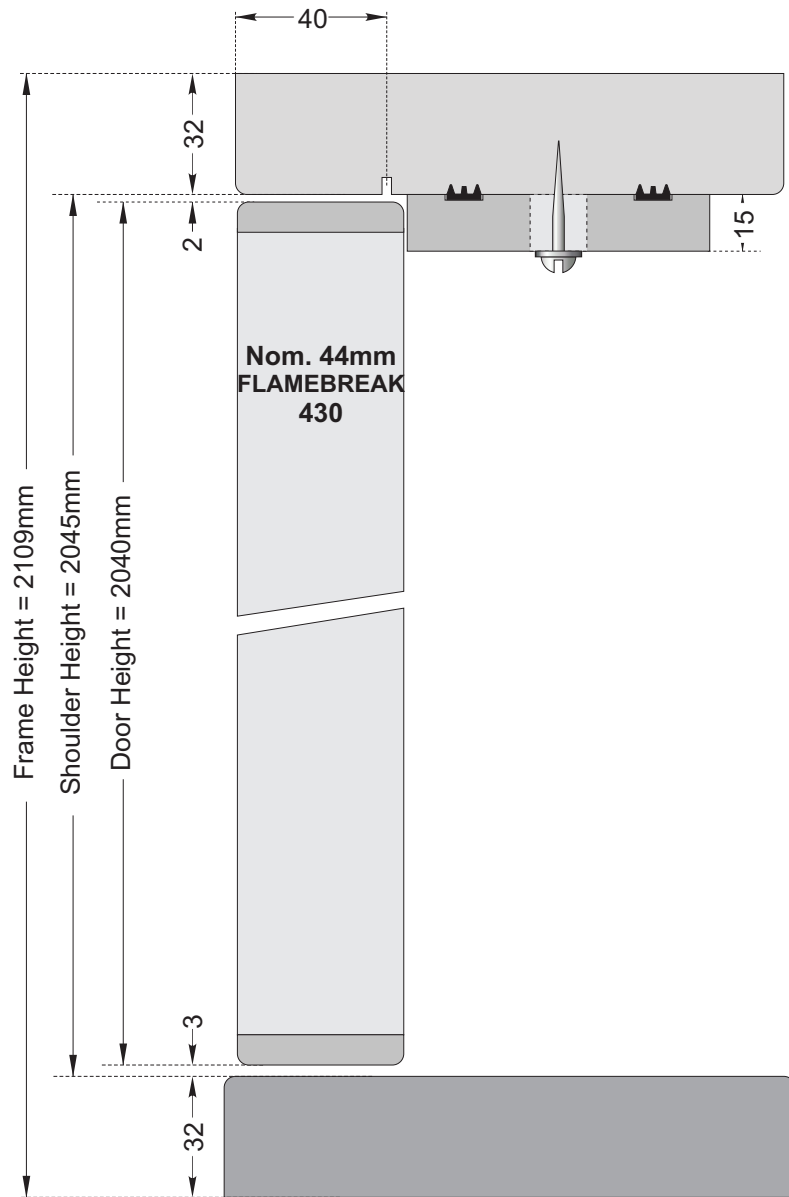

TEST 44: Flamebreak 430 Fully Caulked. = **Rw.30dB SRL Test 55**

Dwg. Ref:	Sk/AHP/160208/T046		
TITLE	NORSOUND Acoustic Tests Test 44 FLAMEBREAK 430		
Scale	1 : 2	Date	16/6/08
Revisions			

Tony Palmer
Invented 2000

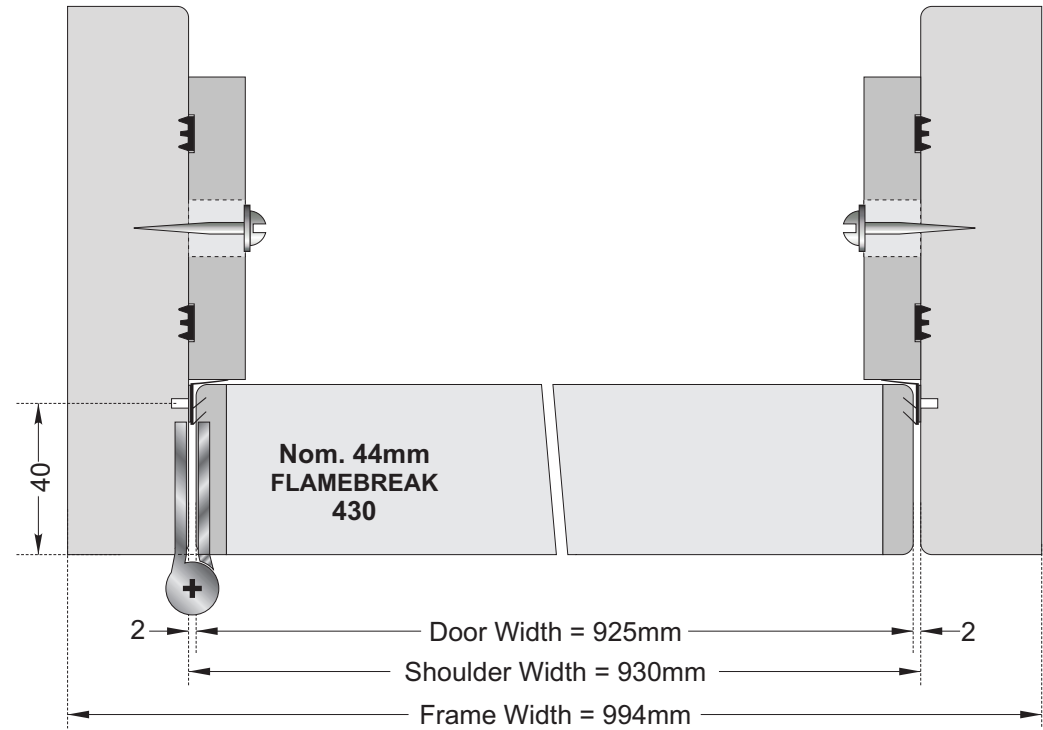
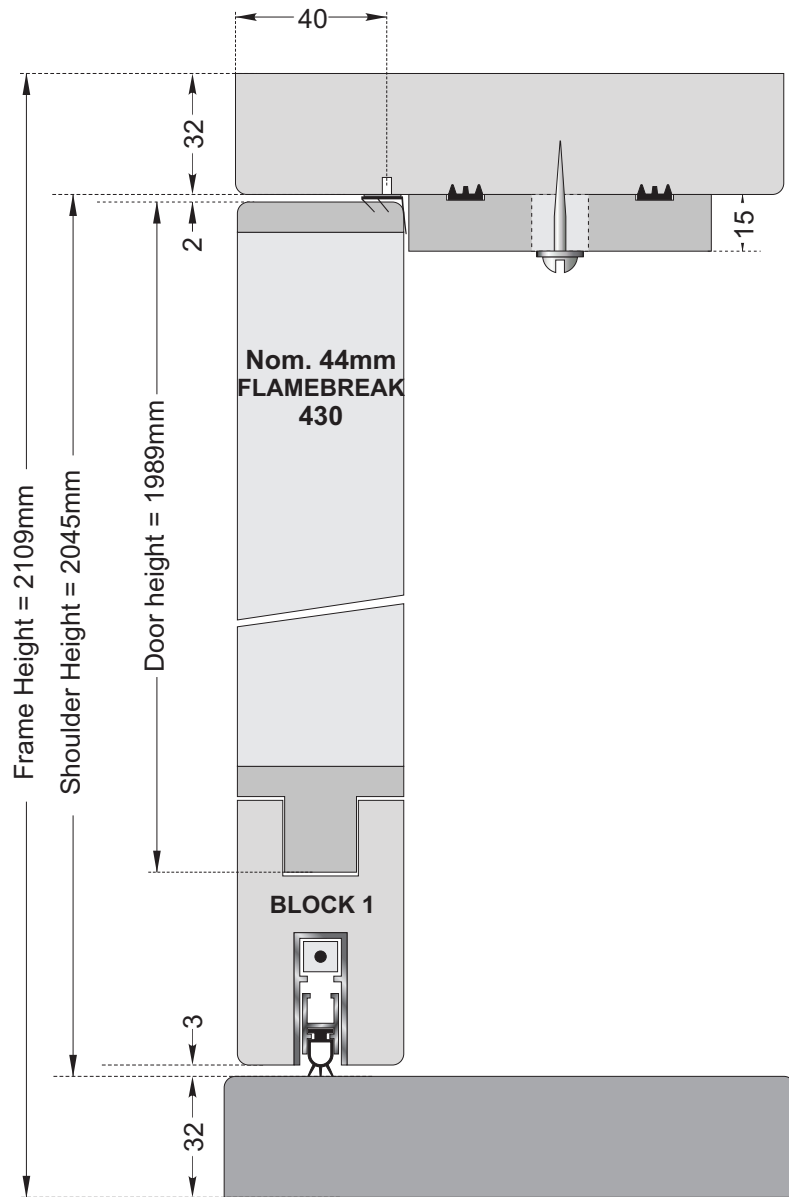

TEST 45: NORSOUND 710 to Head & Jambs. NORSOUND 810 to Threshold.
= Rw.29dB SRL Test 56.

Dwg. Ref:	Sk/AHP/160208/T047		
TITLE	NORSOUND Acoustic Tests Test 45 FLAMEBREAK 430		
Scale	1 : 2	Date	16/6/08
Revisions			

Tony Palmer
Invented 2000

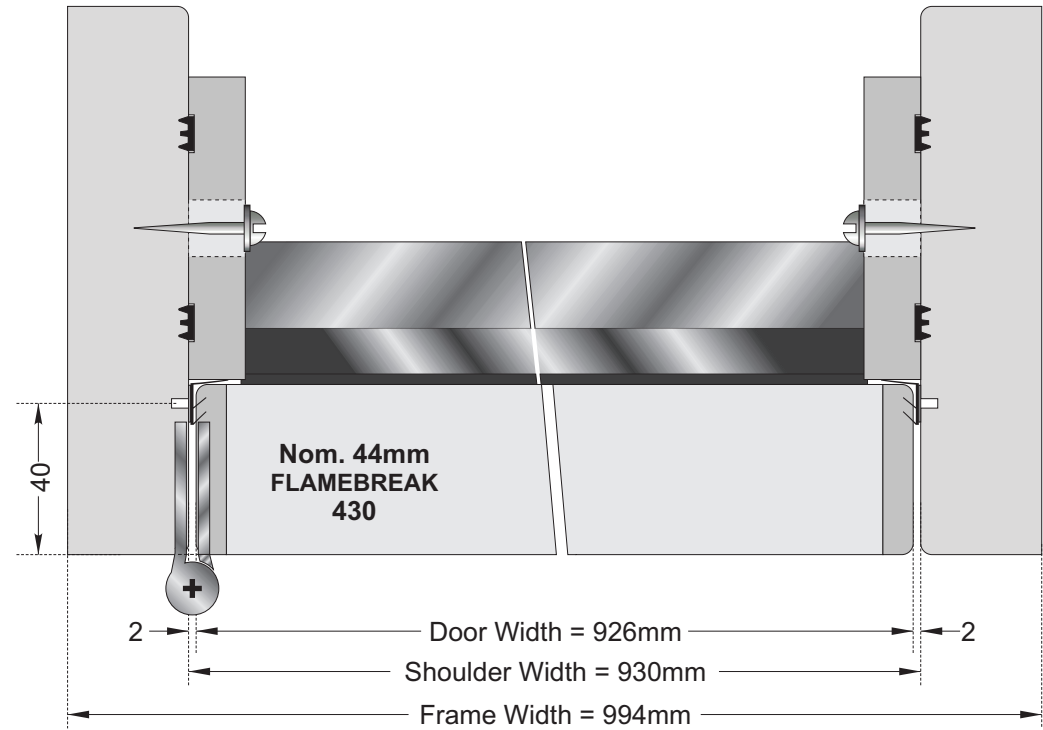
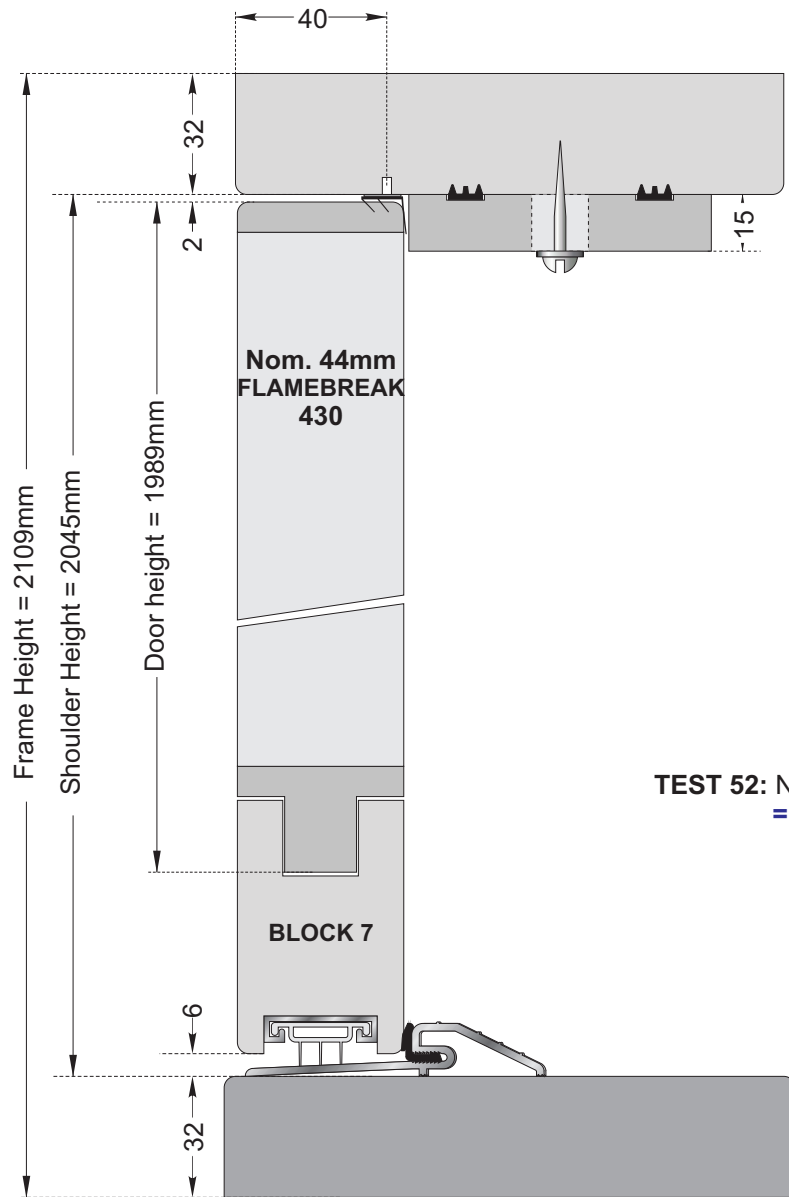

TEST 52: NORSOUND 710 to Head & Jambs. NORSOUND 850 used with NORSOUND 650 Threshold.
= **Rw.30dB SRL Test 57.**

Dwg. Ref:	Sk/AHP/160208/T048		
TITLE	NORSOUND Acoustic Tests Test 52 FLAMEBREAK 430		
Scale	1 : 2	Date	16/6/08
Revisions			

Tony Palmer
Smartech 2000

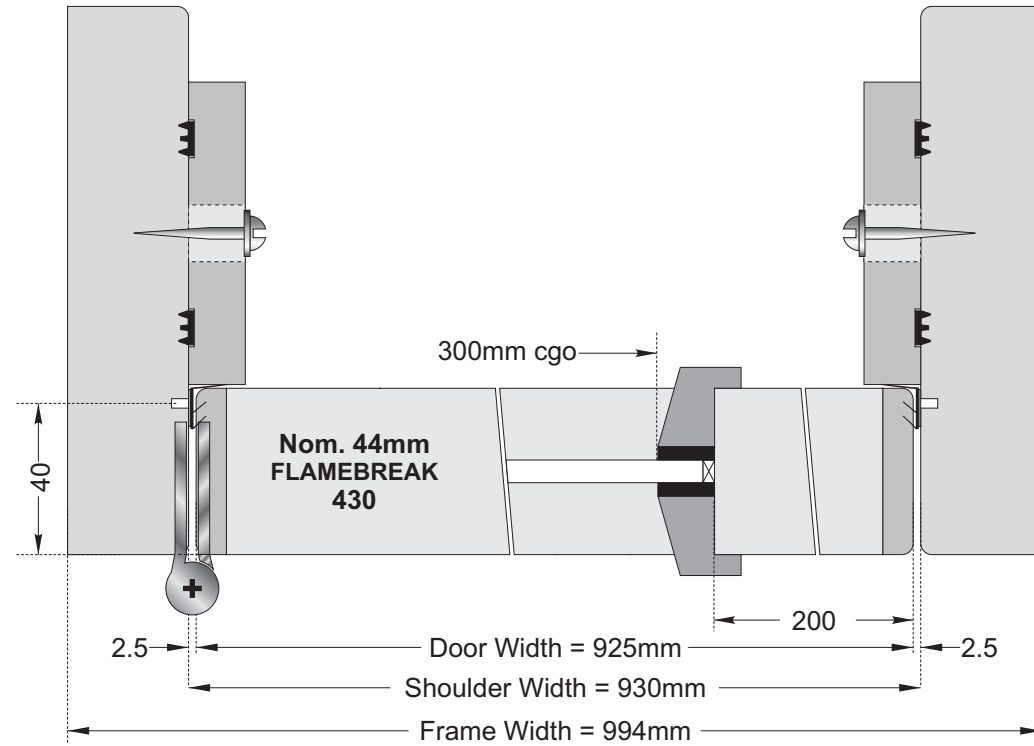
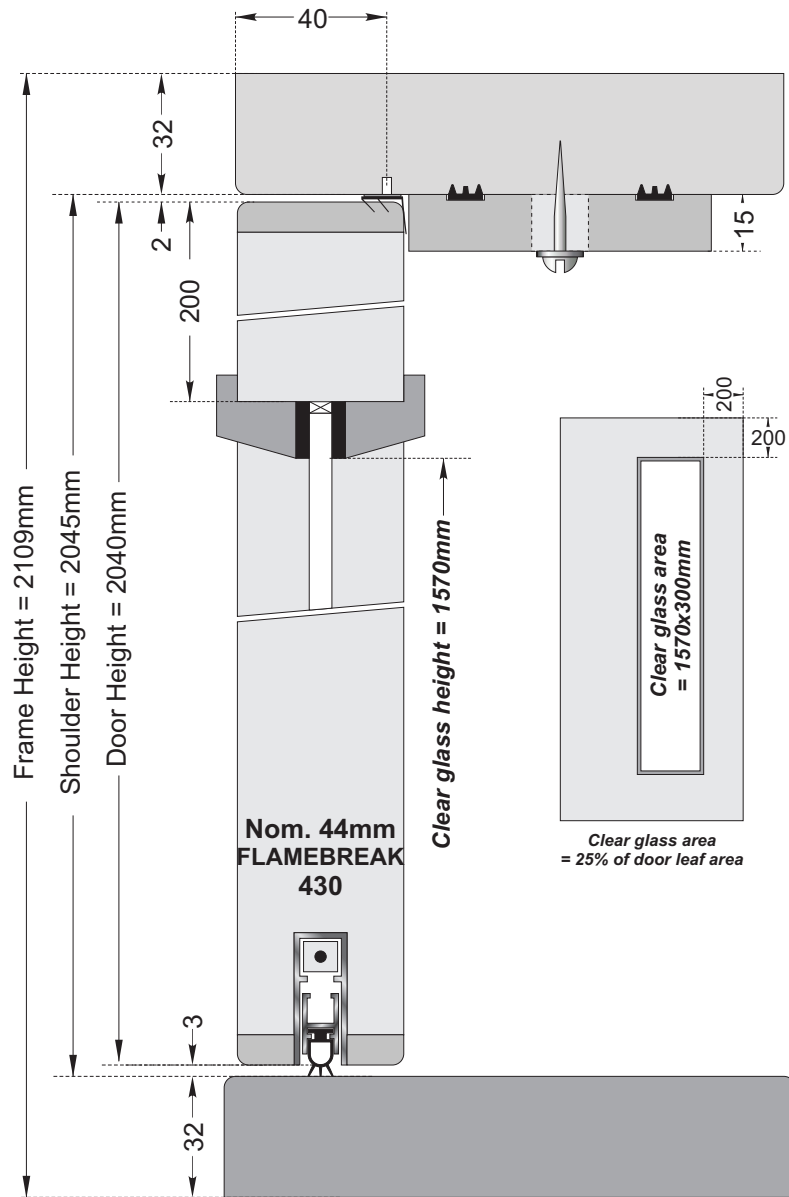

TEST 75: Nom. 6mm Pyroshield glass. NORSOUND 710 to Head & Jambs.
NORSOUND 810 to Threshold. = **Rw.31dB. SRL Test 49.**

Dwg. Ref:	Sk/AHP/160208/T049		
TITLE	NORSOUND Acoustic Tests Test 75 FLAMEBREAK 430		
Scale	1 : 2	Date	16/6/08
Revisions			

Tony Palmer
Invented 2000

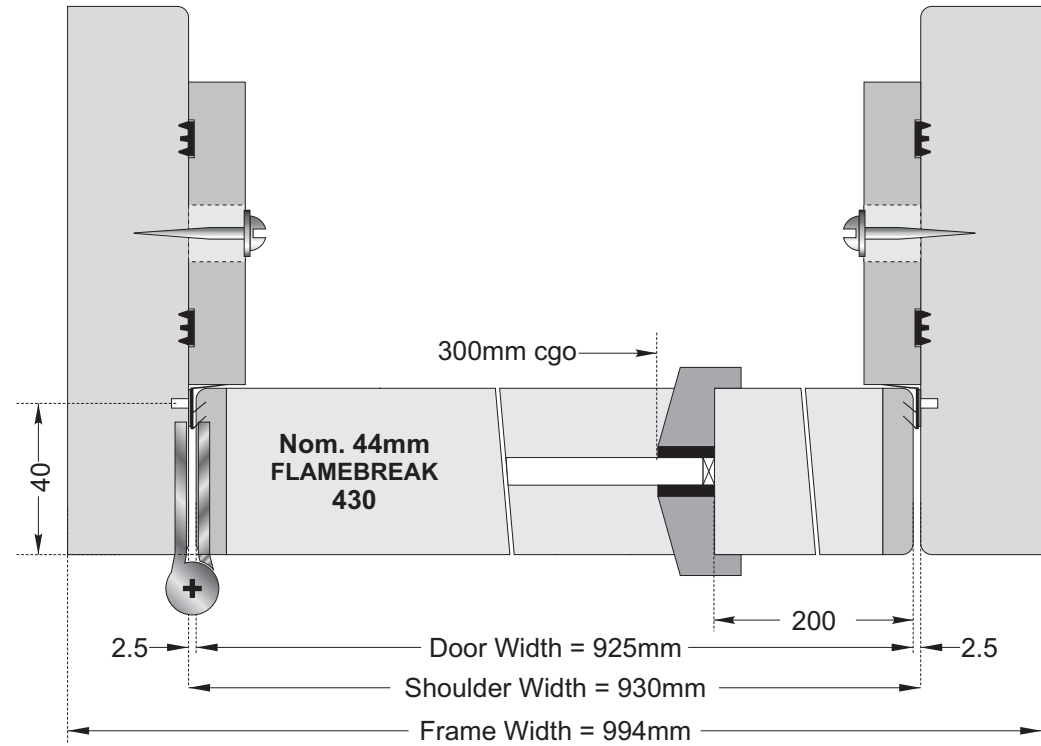
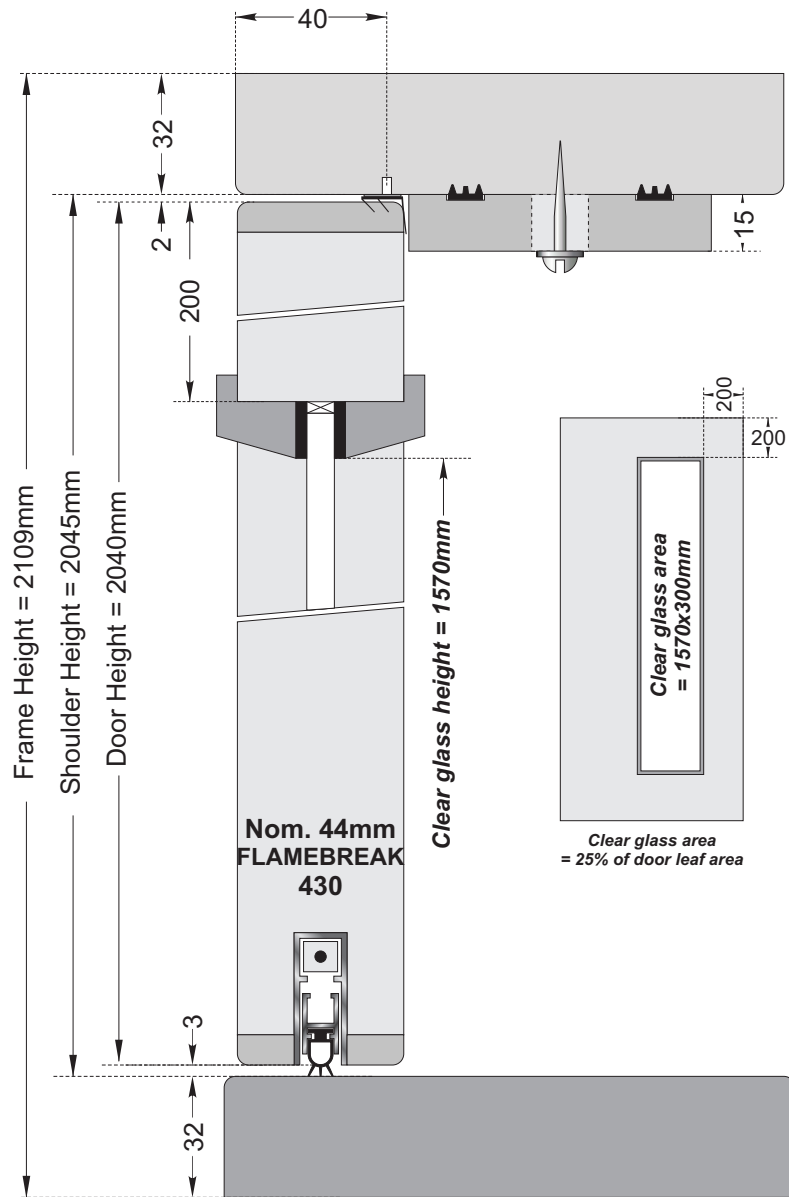

TEST 76: Nom. 7mm Pyrobelite glass. NORSOUND 710 to Head & Jambs.
NORSOUND 810 to Threshold. = **Rw.32dB. SRL Test 52.**

Dwg. Ref:	Sk/AHP/160208/T050		
TITLE	NORSOUND Acoustic Tests Test 76 FLAMEBREAK 430		
Scale	1 : 2	Date	16/6/08
Revisions			

Tony Palmer
Invented 2000

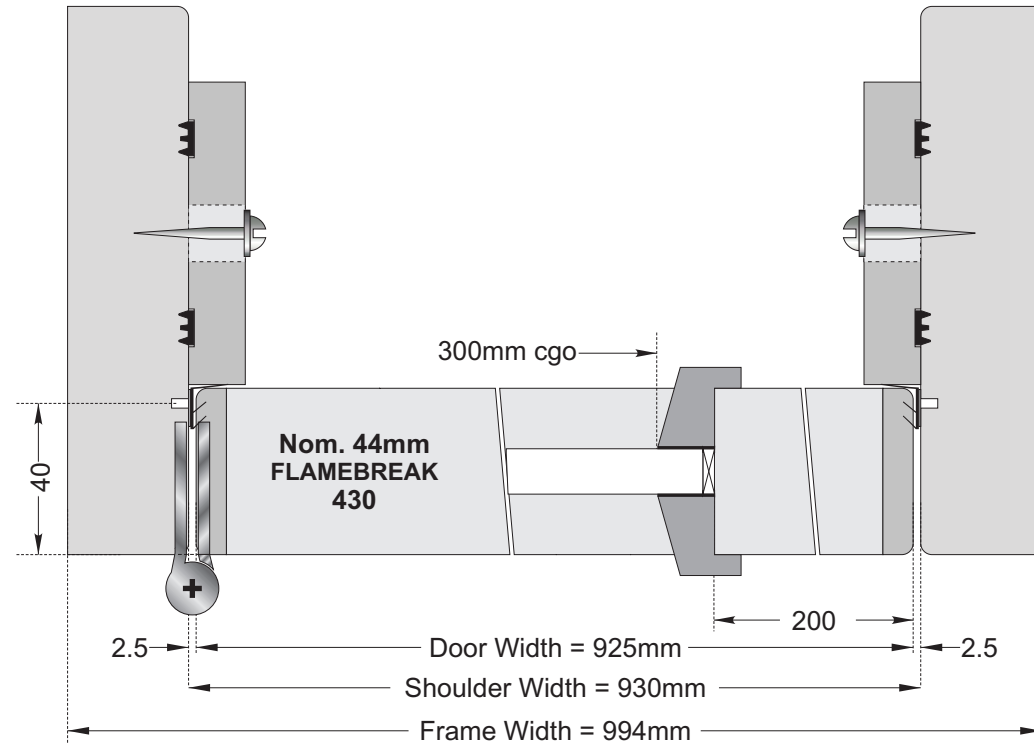
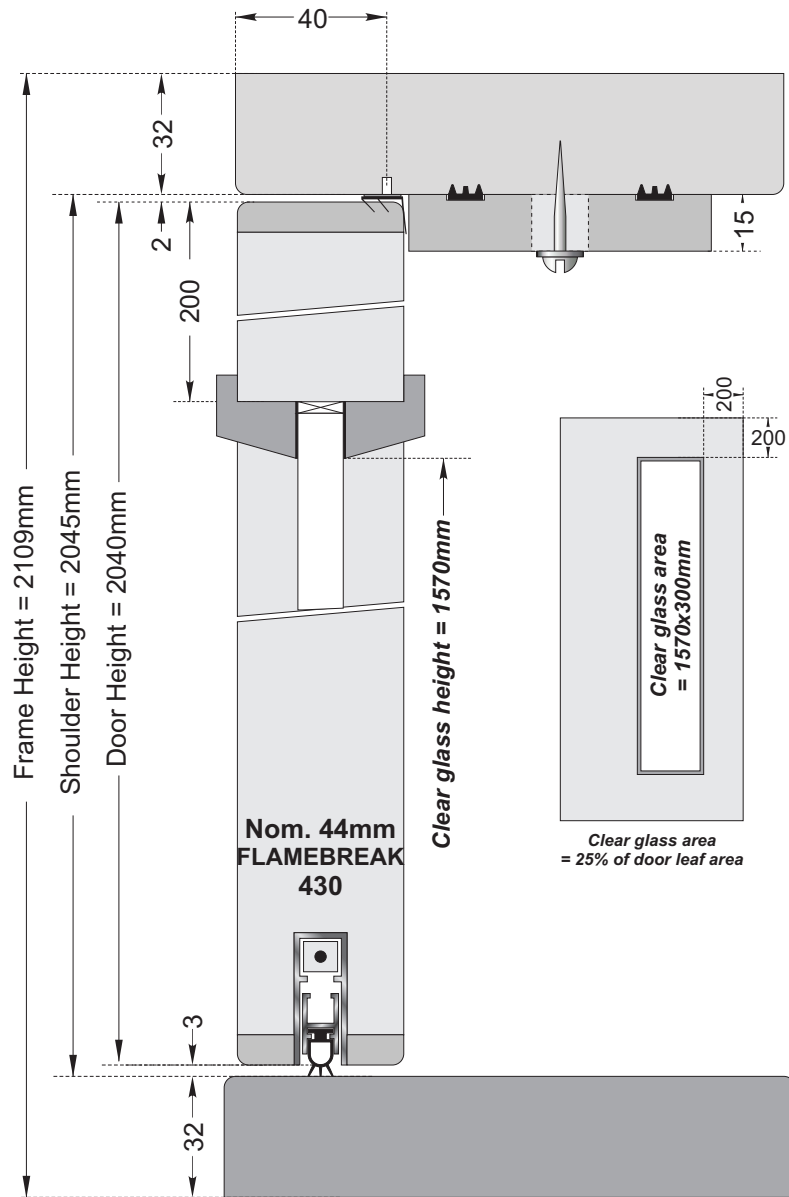

TEST 77a: Nom. 12mm Pyrobelite glass. NORSOUND 710 to Head & Jambs.
NORSOUND 810 to Threshold. = **Rw.32dB. SRL Test 48.**

Dwg. Ref:	Sk/AHP/160208/T051		
TITLE	NORSOUND Acoustic Tests Test 77a FLAMEBREAK 430		
Scale	1 : 2	Date	16/6/08
Revisions			

Tony Palmer
Invented 2000

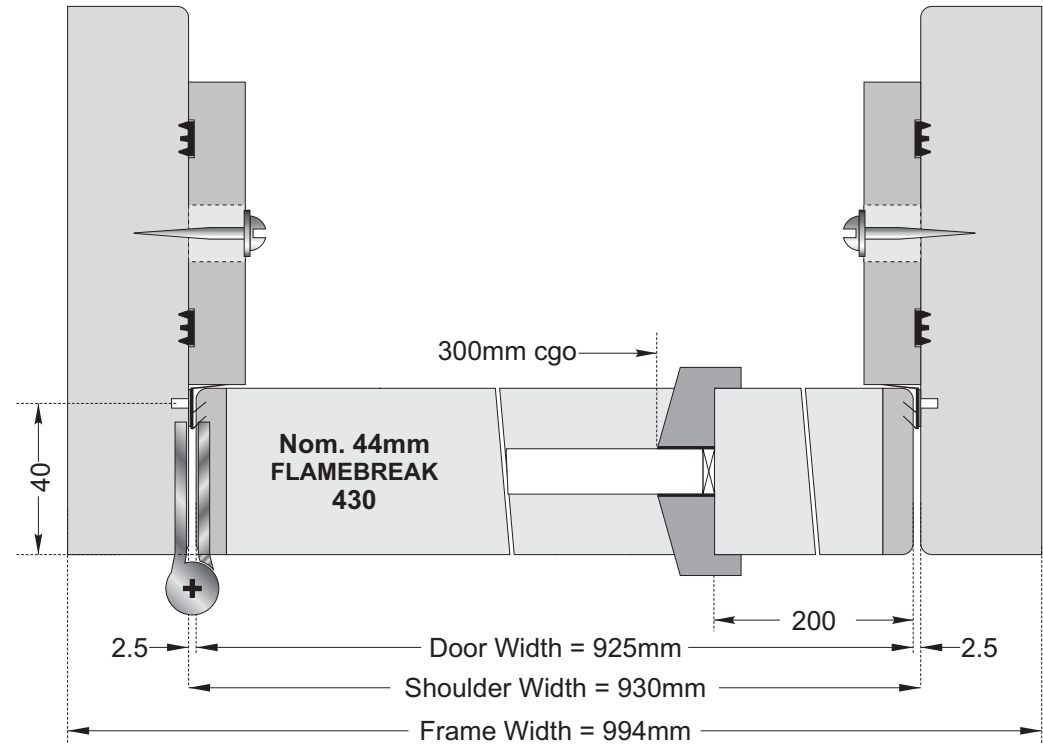
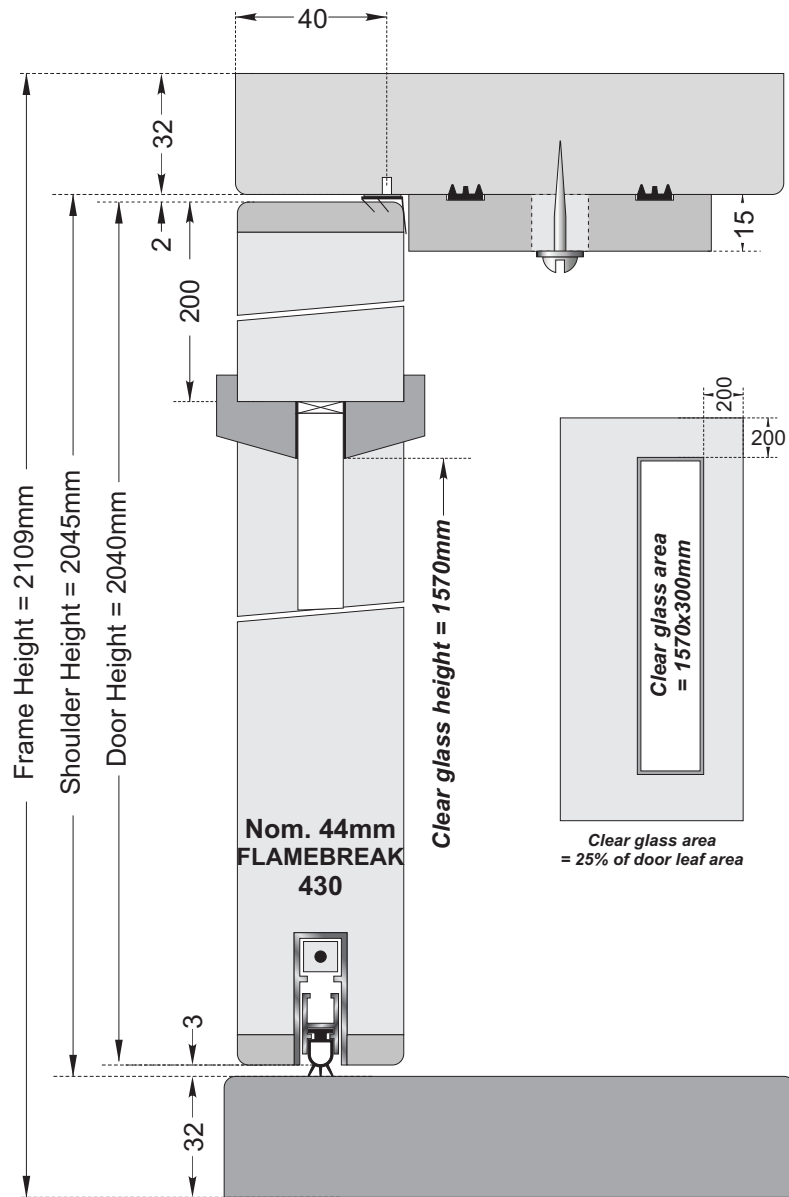

TEST 77b: Nom. 11.5mm 3 Ply7 PA Res. Glass. NORSOUND 710 to Head & Jamb.
NORSOUND 810 to Threshold. = **Rw.31dB**. SRL Test 51.

Dwg. Ref:	Sk/AHP/160208/T052		
TITLE	NORSOUND Acoustic Tests Test 77b FLAMEBREAK 430		
Scale	1 : 2	Date	16/6/08
Revisions			

Tony Palmer
Invented 2000

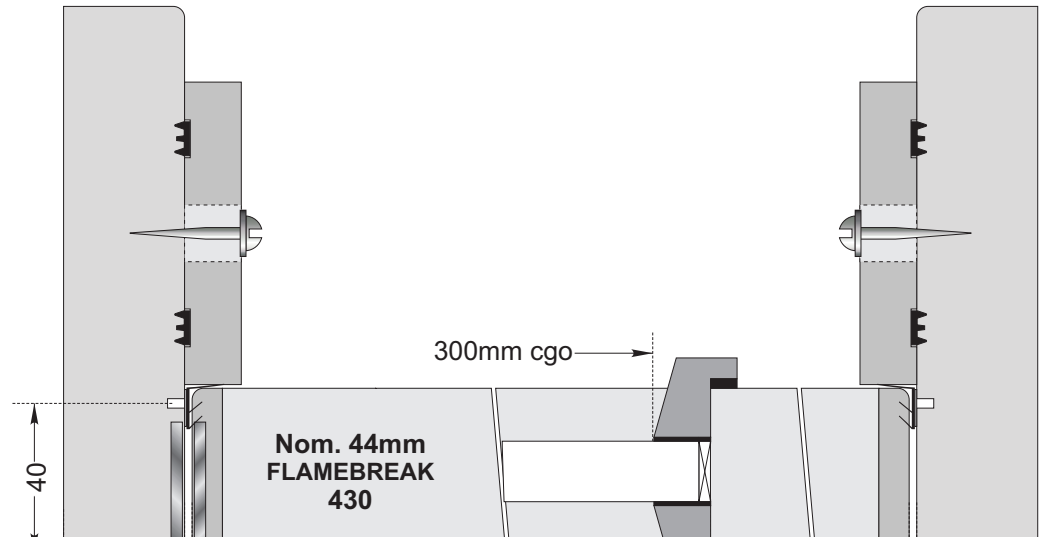
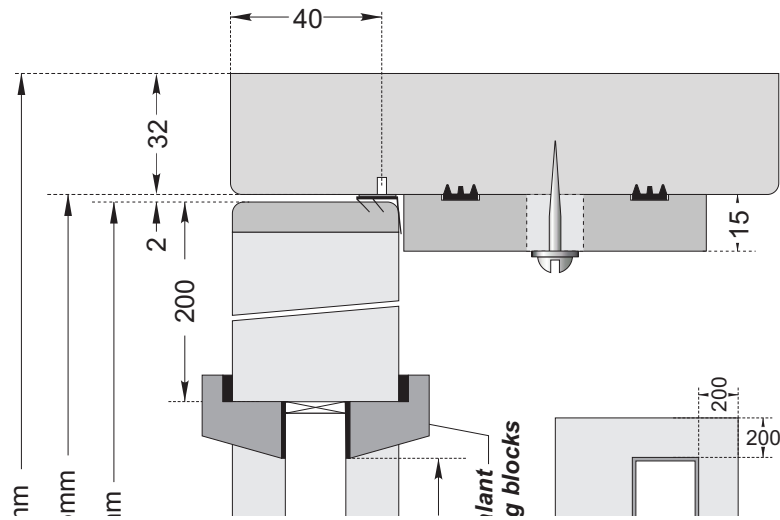

P:\C20000s-Tech Services\C20150\20184\Correspondence\R01
© Sound Research Laboratories Ltd

C/08/5L/20184/R01

1 September 2008

Page 200 of 50

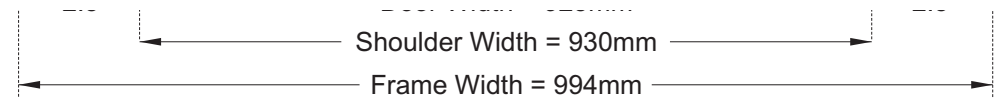
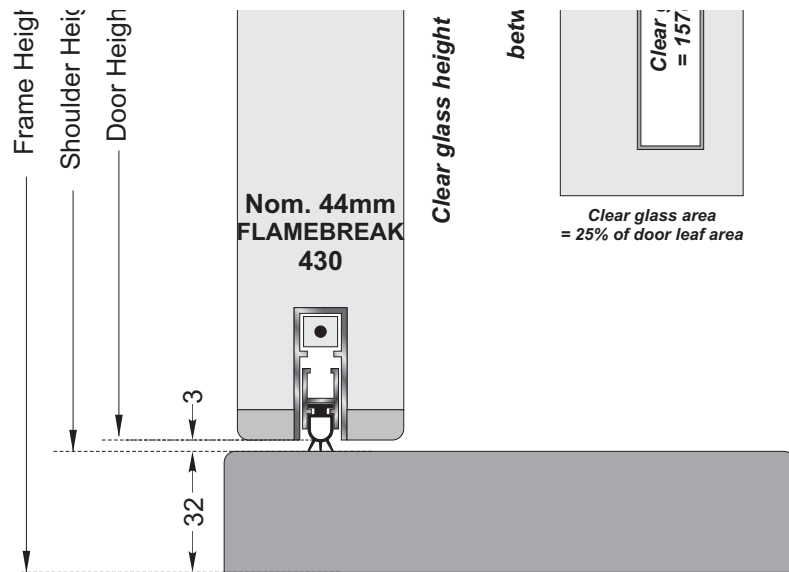

TEST 78a: Nom. 16mm Pyrobel Glass. NORSOUND 710 to Head & Jamb.
NORSOUND 810 to Threshold. = **Rw.32dB. SRL Test 50.**

Dwg. Ref:	Sk/AHP/160208/T053		
TITLE	NORSOUND Acoustic Tests Test 78a FLAMEBREAK 430		
Scale	1 : 2	Date	16/6/08
Revisions			

Tony Palmer
Dorset 2000

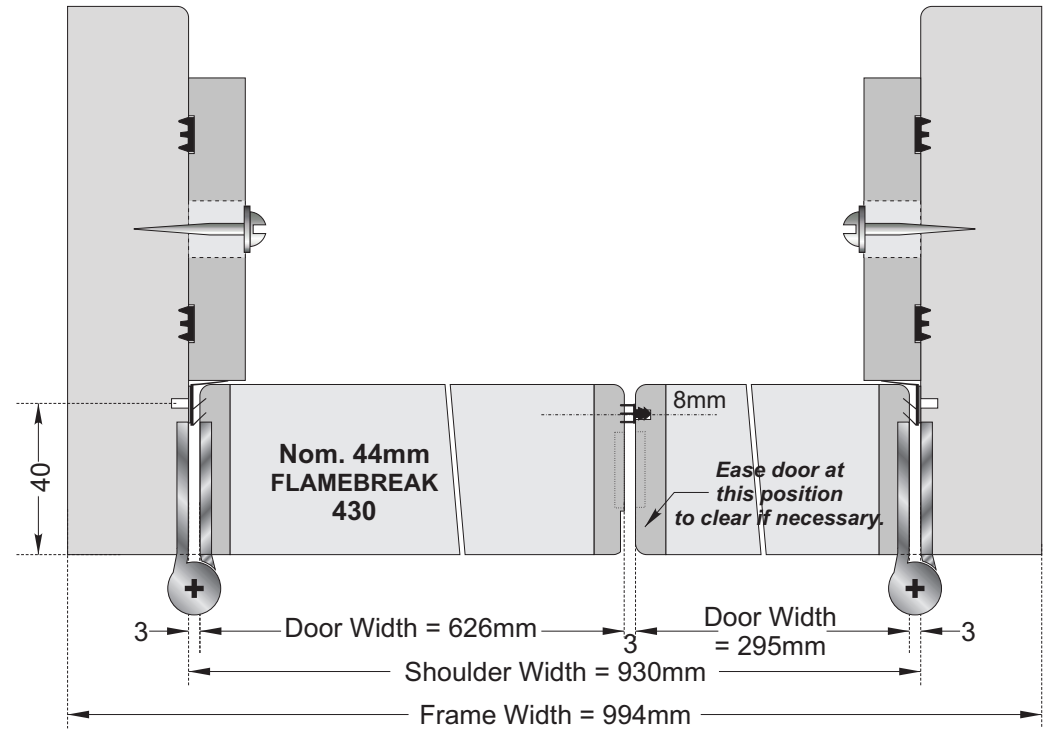
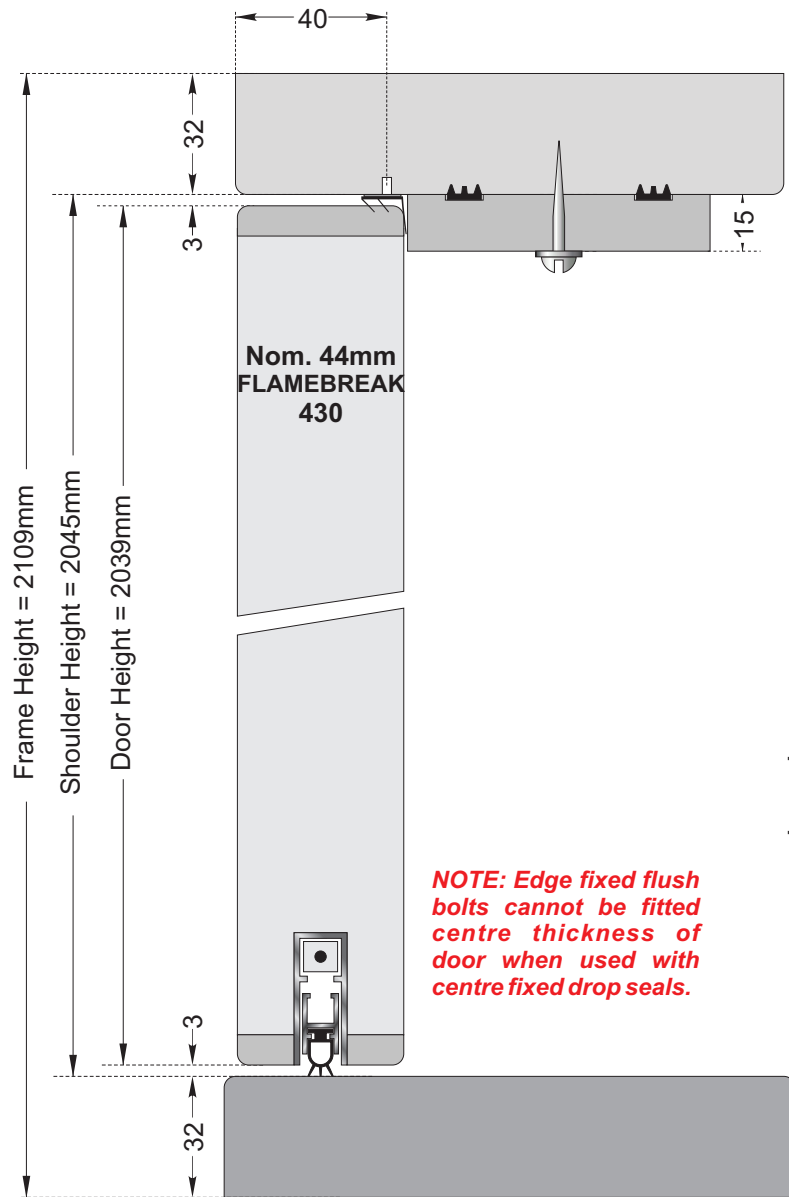

TEST 98a: NORSOUND 710 to Head & Jambs + NORSOUND 810 to threshold of each door. NORSOUND 720 at Meeting Stiles. = **Rw.30dB. SRL Test 72.**

TEST 98a: Fully caulked Flamebreak 430 unequal pair. = **Rw.32dB. SRL Test 73.**

Dwg. Ref:	Sk/AHP/160208/T054		
TITLE	NORSOUND Acoustic Tests Test 98a & 98b FLAMEBREAK 430		
Scale	1 : 2	Date	16/6/08
Revisions			

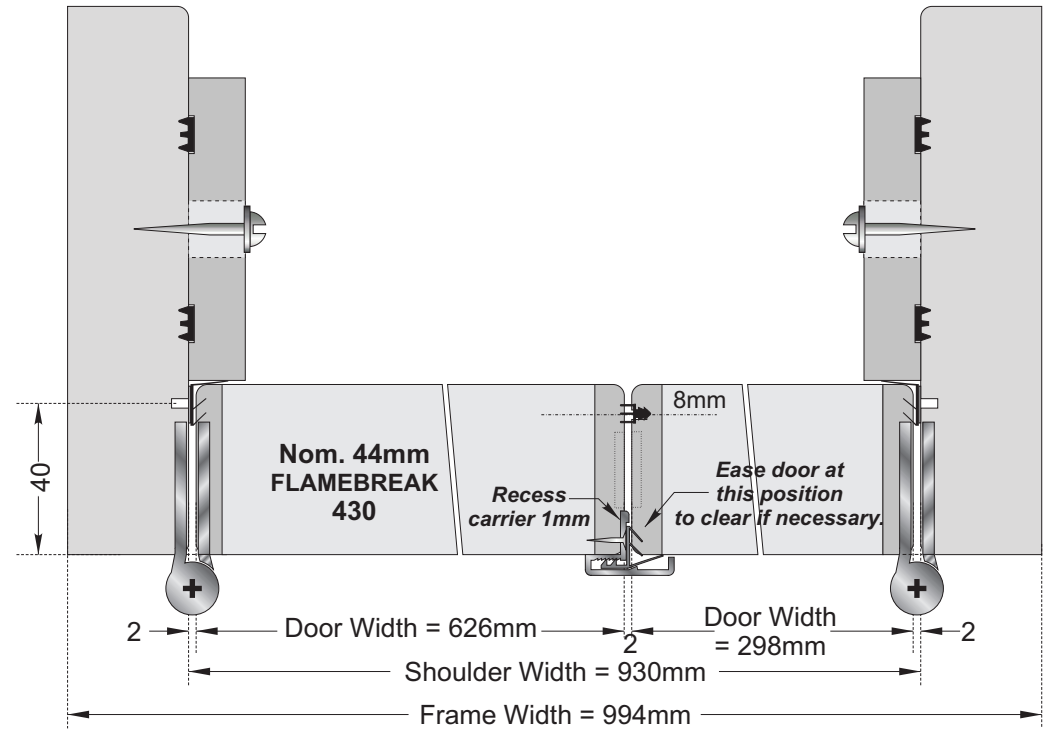
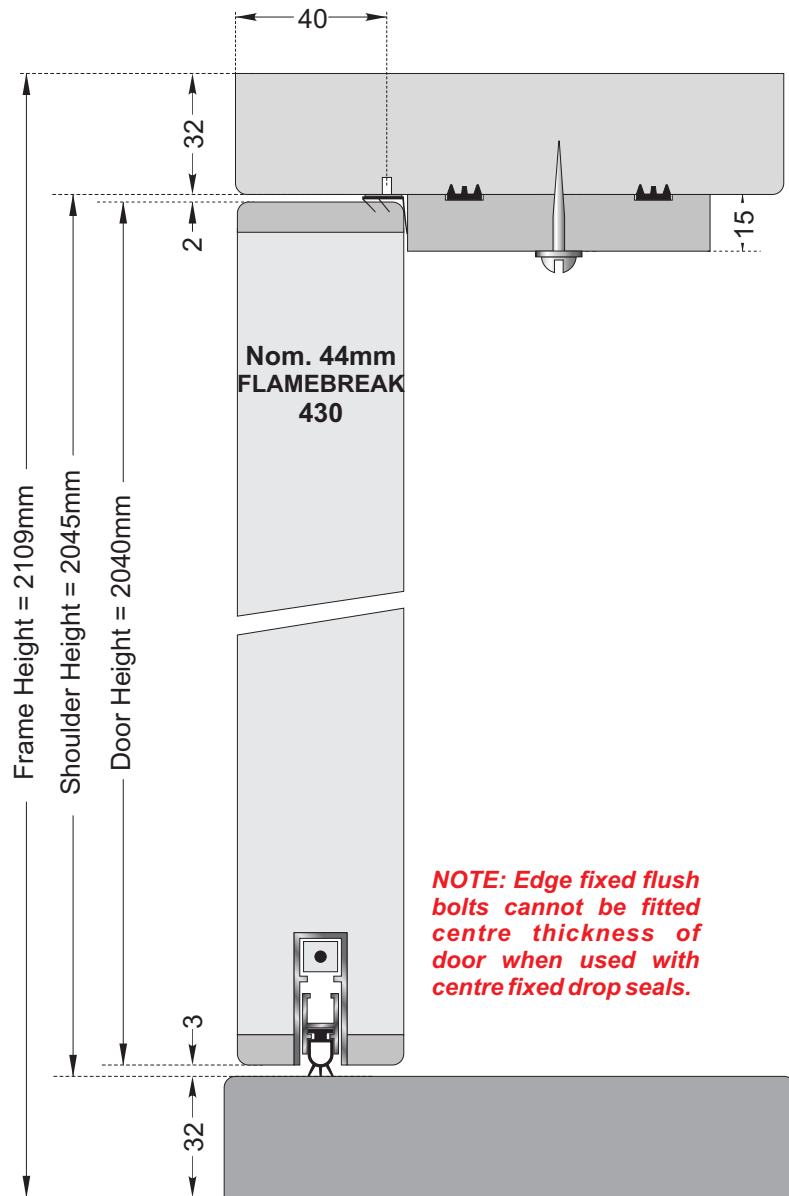

TEST 96: NORSOUND 710 to Head & Jambs + NORSOUND 810 to threshold of each door.
NORSOUND 720 and NORSOUND 510 at Meeting Stiles.
=Rw.30dB.SRL Test 69.

Dwg. Ref:	Sk/AHP/160208/T055		
TITLE	NORSOUND Acoustic Tests Test 96 FLAMEBREAK 430		
Scale	1 : 2	Date	16/6/08
Revisions			

Tony Palmer
Invented 2000

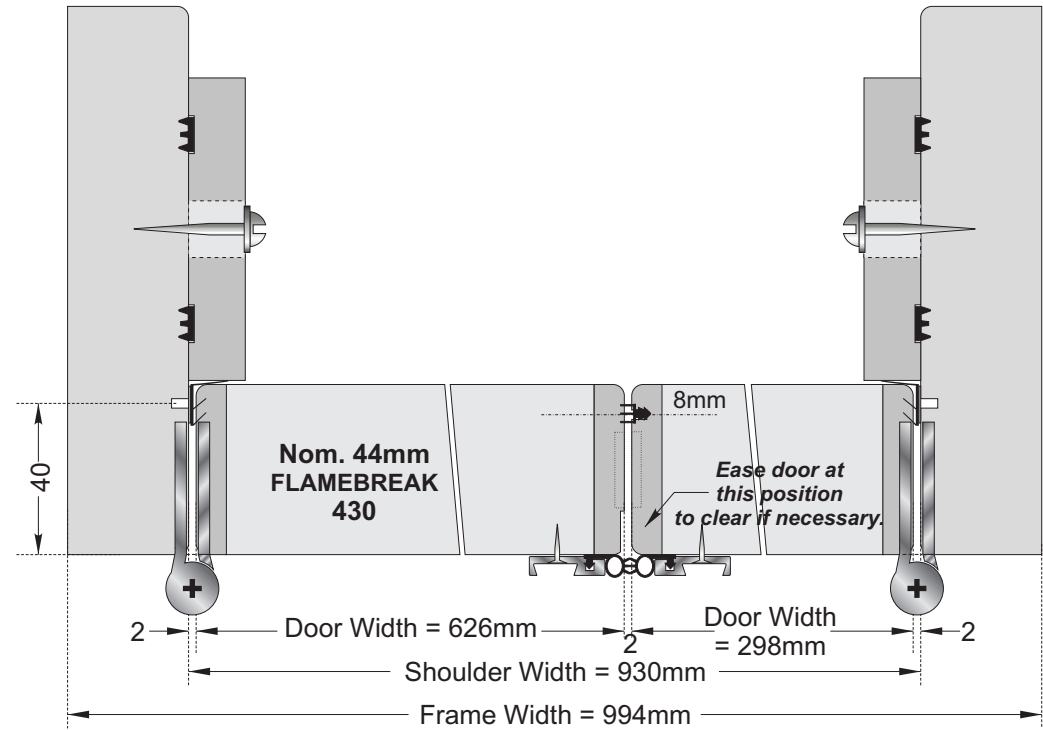
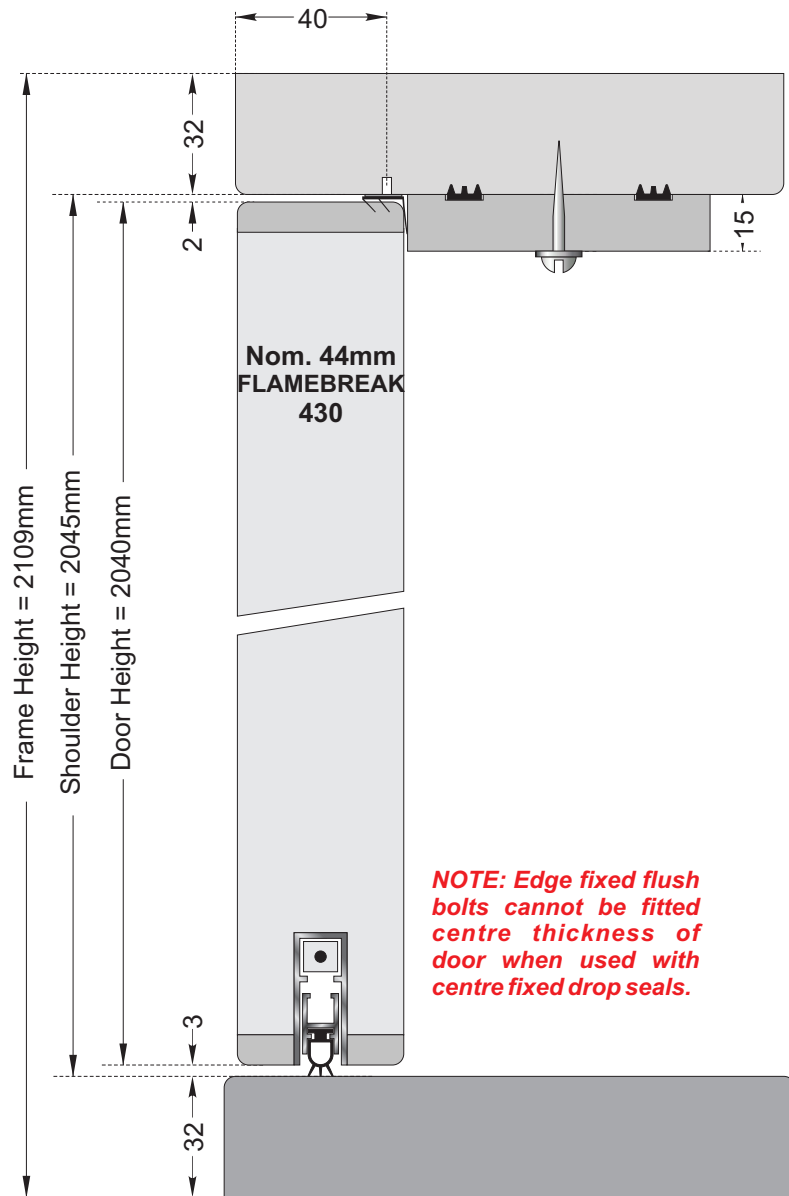

TEST 97: NORSOUND 710 to Head & Jambs + NORSOUND 810 to threshold of each door.
NORSOUND 720 and 2No. NORSOUND 755 at Meeting Stiles.
= Rw.31dB. SRL Test 70.

Dwg. Ref:	Sk/AHP/160208/T056		
TITLE	NORSOUND Acoustic Tests Test 97 FLAMEBREAK 430		
Scale	1 : 2	Date	16/6/08
Revisions			

Tony Palmer
Invented 2000

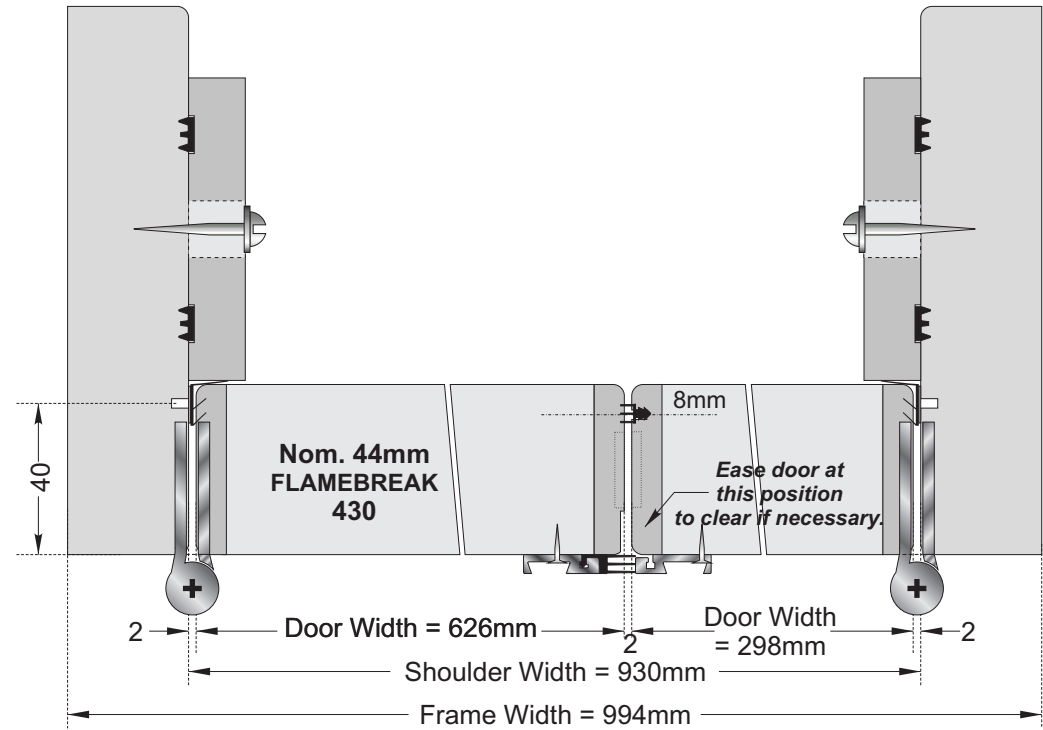
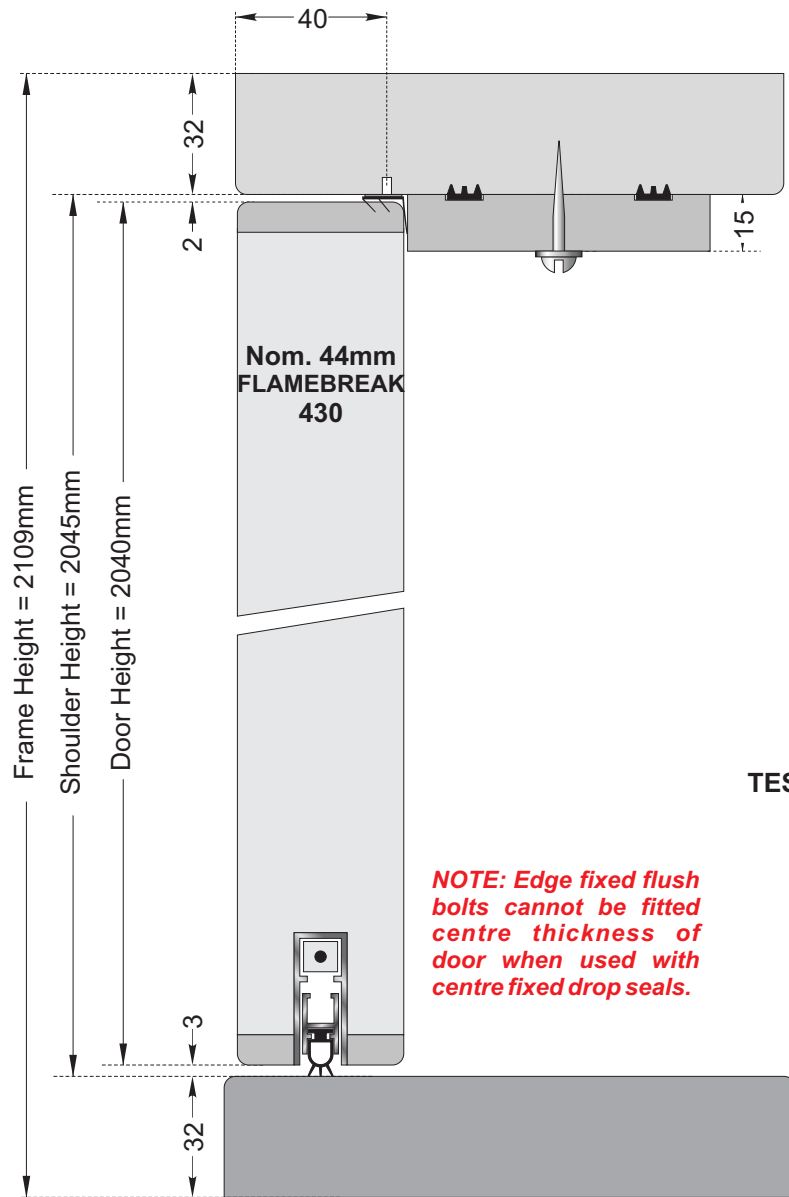

TEST 98: NORSOUND 710 to Head & Jambs + NORSOUND 810 to threshold of each door.
 NORSOUND 855 + NORSOUND 855 Carrier only + NORSOUND 720 at Meeting Stiles.
 = **Rw.31dB. SRL Test 71.**

Dwg. Ref:	Sk/AHP/160208/T057		
TITLE	NORSOUND Acoustic Tests Test 98 FLAMEBREAK 430		
Scale	1 : 2	Date	16/6/08
Revisions			

Tony Palmer
Invented 2000

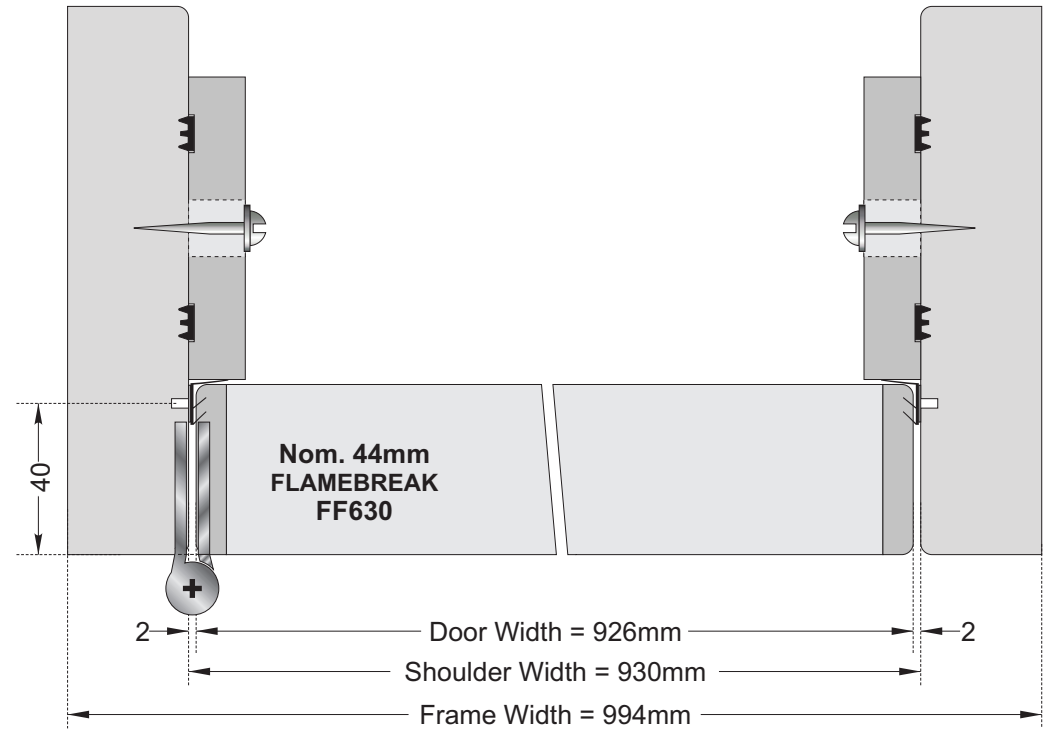
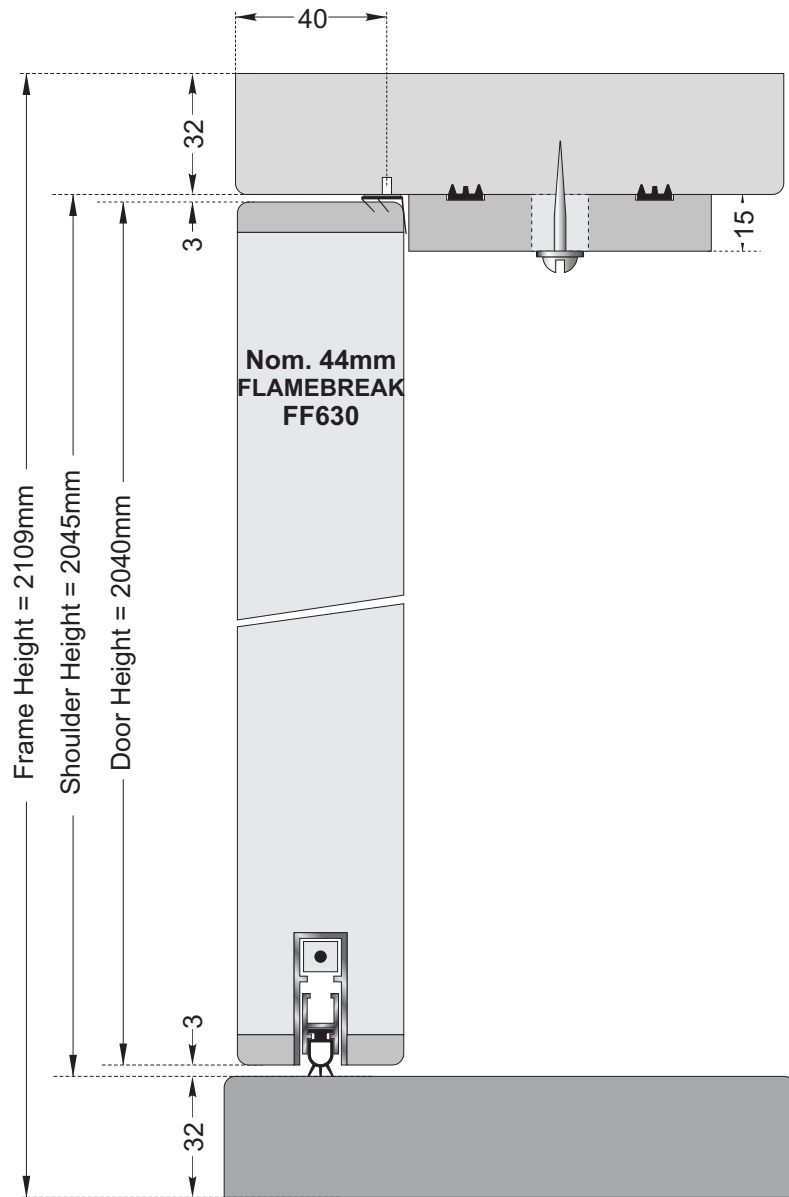

TEST 56a: Fully caulked to establish maximum potential performance for the doorset. = **Rw.30dB SRL Test 79.**

TEST 56: NORSOUND 710 to Head & Jambs. NORSOUND 810 to Threshold. = **Rw.29dB SRL Test 78.**

Dwg. Ref:	Sk/AHP/160208/T059		
TITLE	NORSOUND Acoustic Tests Test 56 & 56a FLAMEBREAK FF630		
Scale	1 : 2	Date	16/6/08
Revisions			

Tony Palmer
Specialist 2000

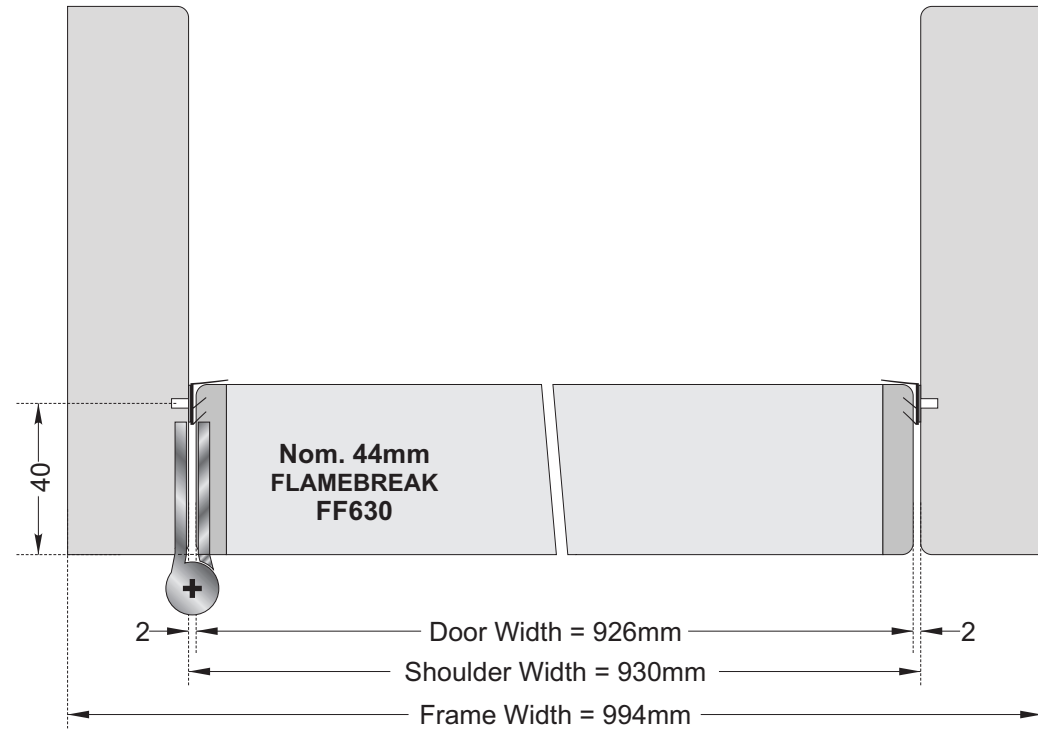
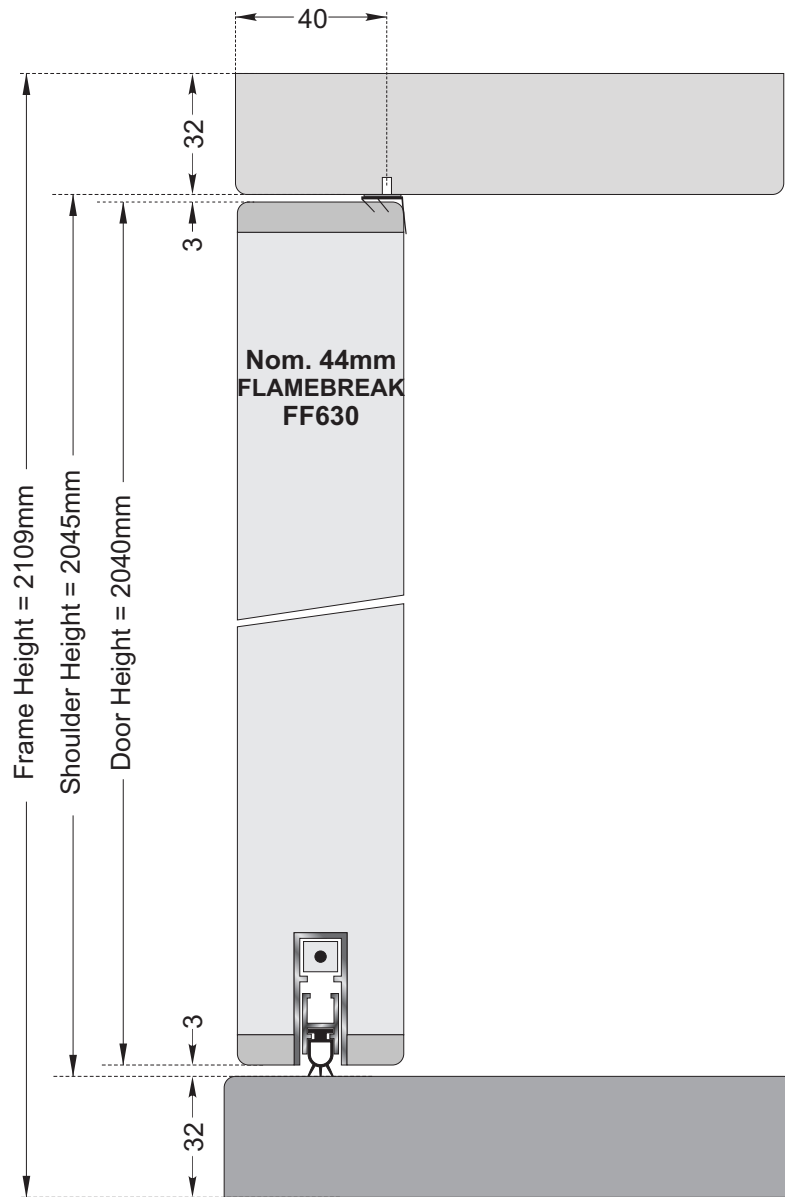

TEST 56b: NORSOUND 710 to Head & Jambs. NORSOUND 810 to Threshold.
FRAME DOORSTOP REMOVED FOR TEST.
= Rw.29dB SRL Test 81.

Dwg. Ref:	Sk/AHP/160208/T060		
TITLE	NORSOUND Acoustic Tests Test 56B FLAMEBREAK FF630		
Scale	1 : 2	Date	16/6/08
Revisions			

Tony Palmer
Smartech 2000

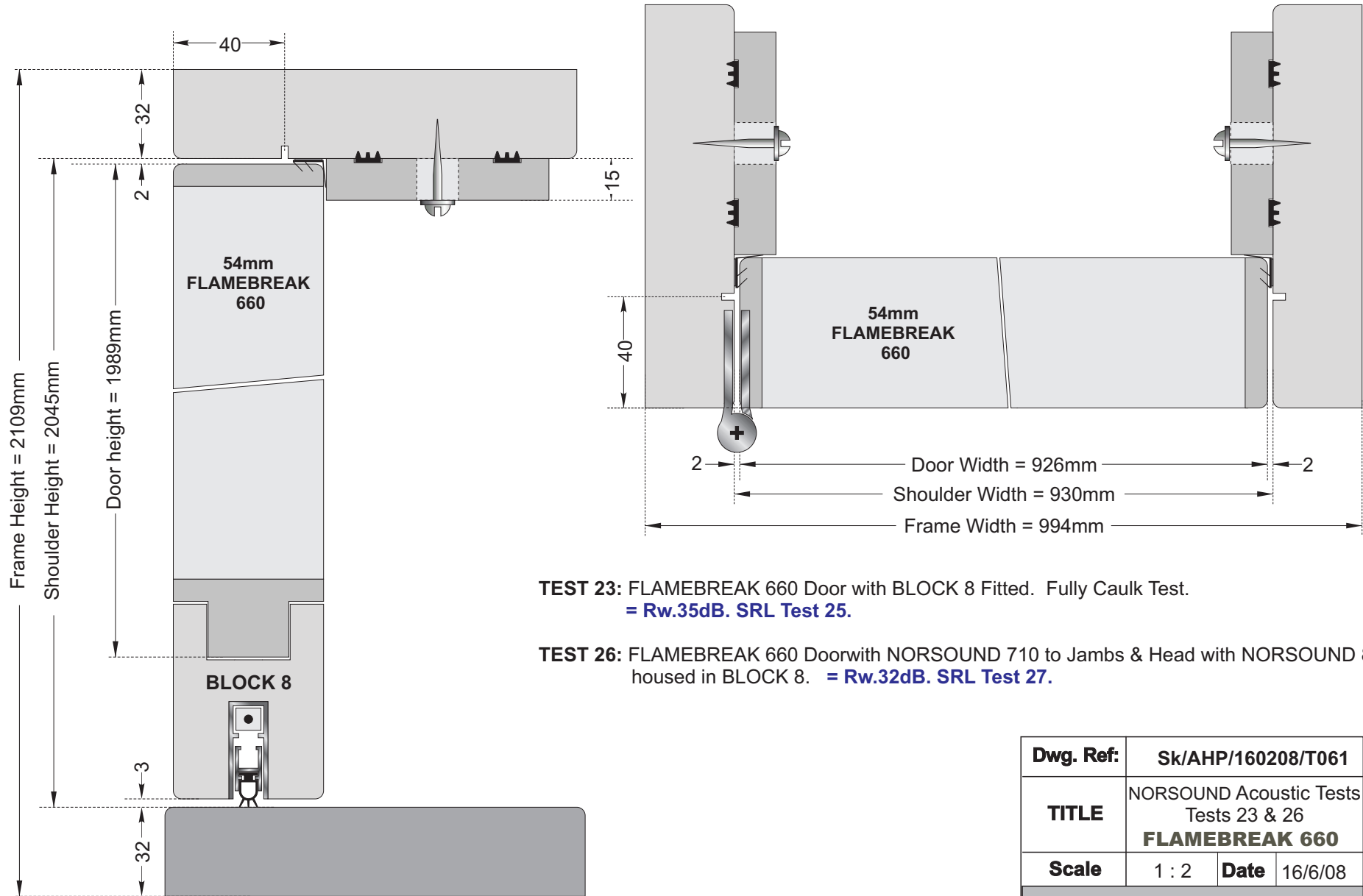

TEST 23: FLAMEBREAK 660 Door with BLOCK 8 Fitted. Fully Caulk Test.
= **Rw.35dB. SRL Test 25.**

TEST 26: FLAMEBREAK 660 Door with NORSOUND 710 to Jambs & Head with NORSOUND 810 housed in BLOCK 8. = **Rw.32dB. SRL Test 27.**

Dwg. Ref:	Sk/AHP/160208/T061		
TITLE	NORSOUND Acoustic Tests Tests 23 & 26 FLAMEBREAK 660		
Scale	1 : 2	Date	16/6/08
Revisions			

Tony Palmer
Smartech 2000

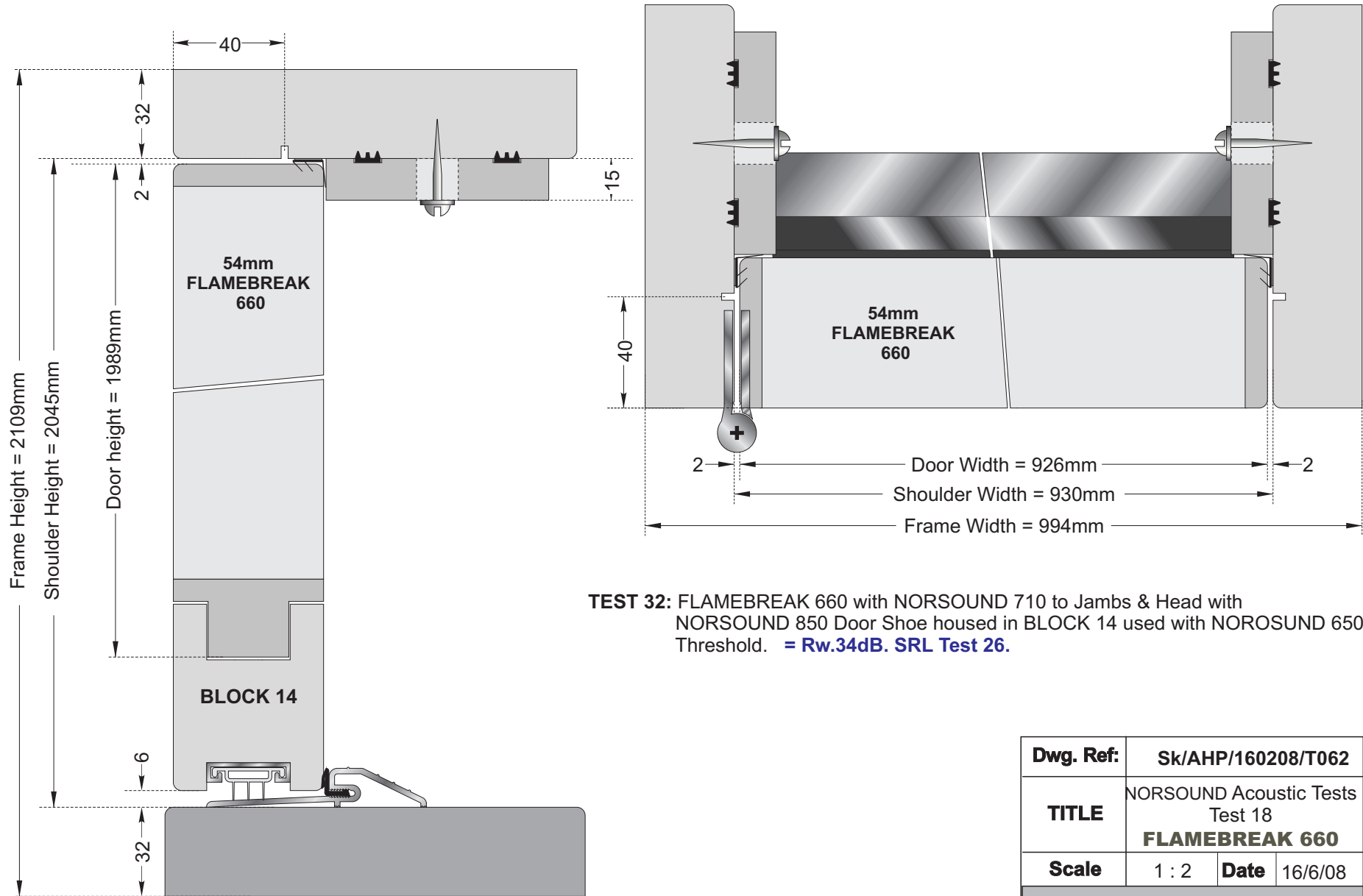

TEST 32: FLAMEBREAK 660 with NORSOUND 710 to Jambs & Head with NORSOUND 850 Door Shoe housed in BLOCK 14 used with NOROSUND 650 Threshold. = **Rw.34dB. SRL Test 26.**

Dwg. Ref:	Sk/AHP/160208/T062		
TITLE	NORSOUND Acoustic Tests Test 18 FLAMEBREAK 660		
Scale	1 : 2	Date	16/6/08
Revisions			

Tony Palmer
Specialist 2000

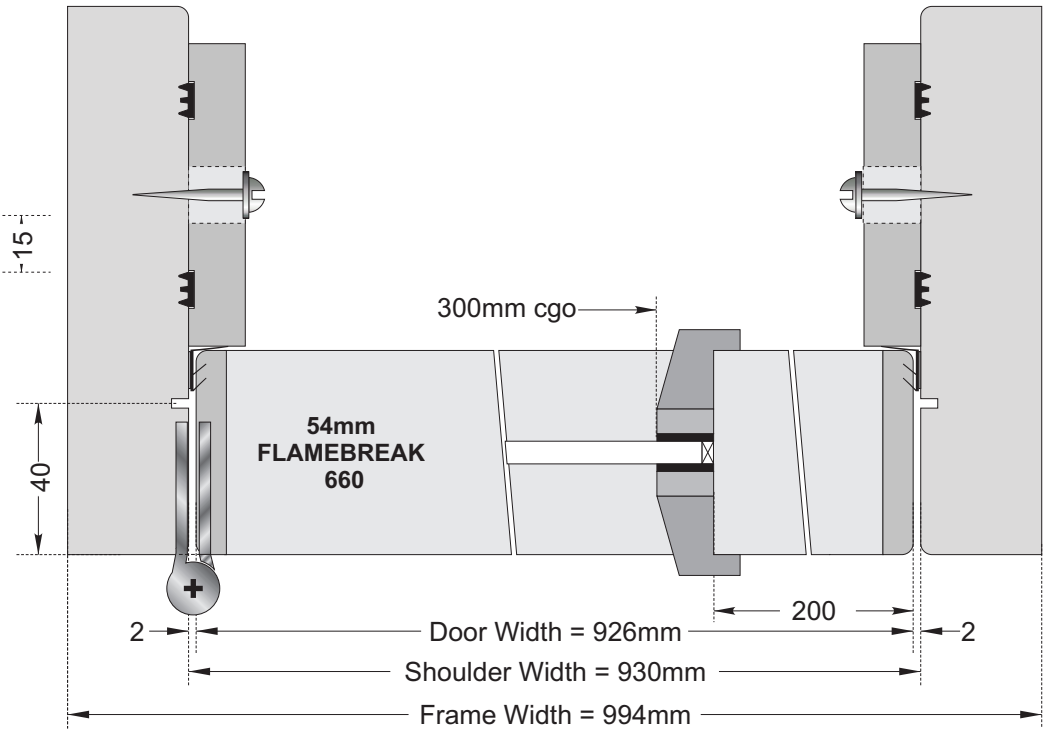
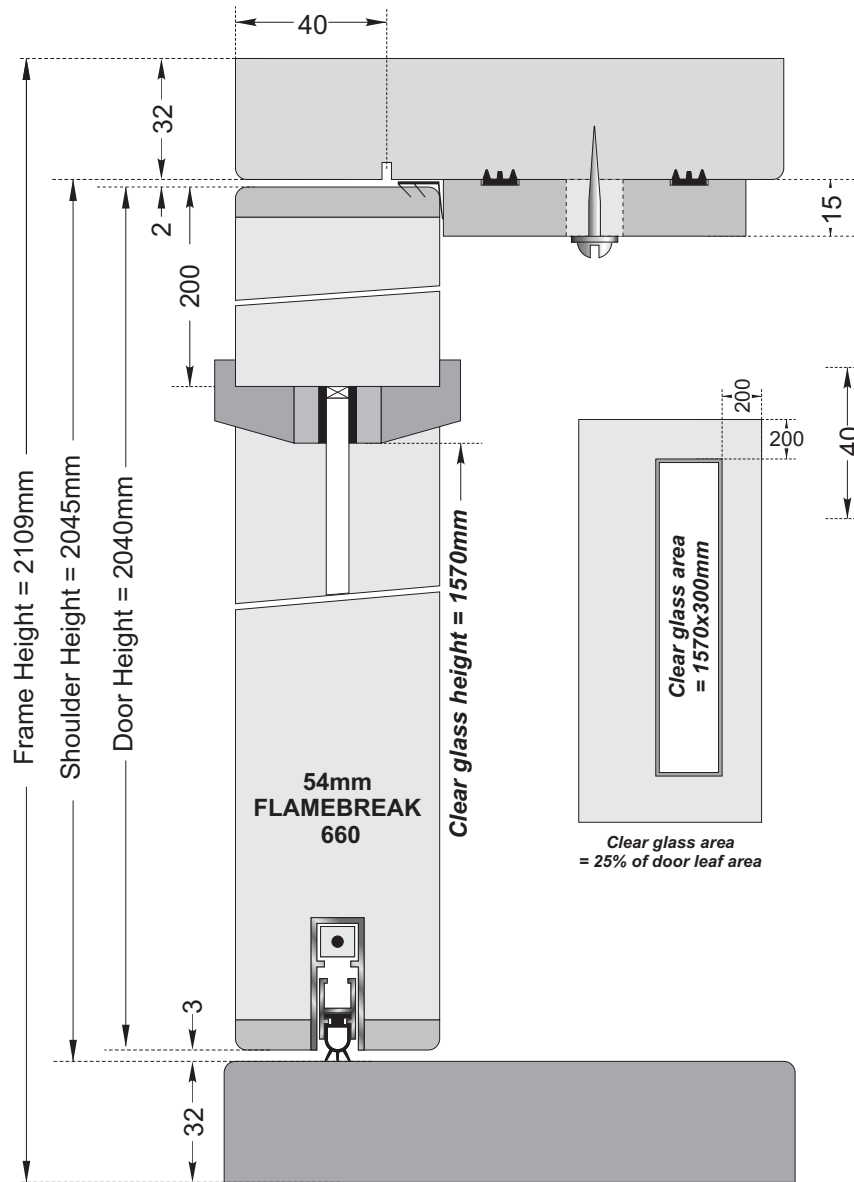

TEST 65 : Nom. 6mm Pyroshield glass. NORSOUND 710 to Head & Jamb.
NORSOUND 810 to Threshold. = **Rw.33dB. SRL Test 33.**

TEST 65a : Nom. 6mm Pyroshield glass. NORSOUND 710 to Head & Jamb.
NORSOUND 810 to Threshold. = **Rw.33dB. SRL Test 39.**

Dwg. Ref:	Sk/AHP/160208/T063		
TITLE	NORSOUND Acoustic Tests Test 65 & 65a FLAMEBREAK 660		
Scale	1 : 2	Date	16/6/08
Revisions			

Tony Palmer
Invented 2000

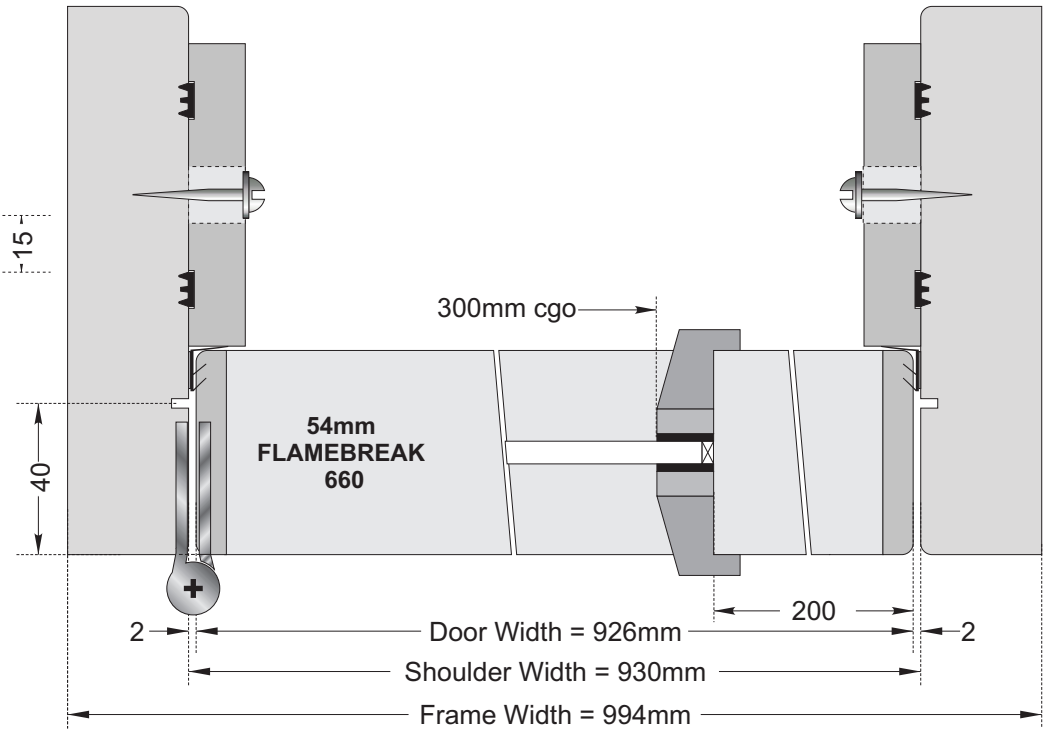
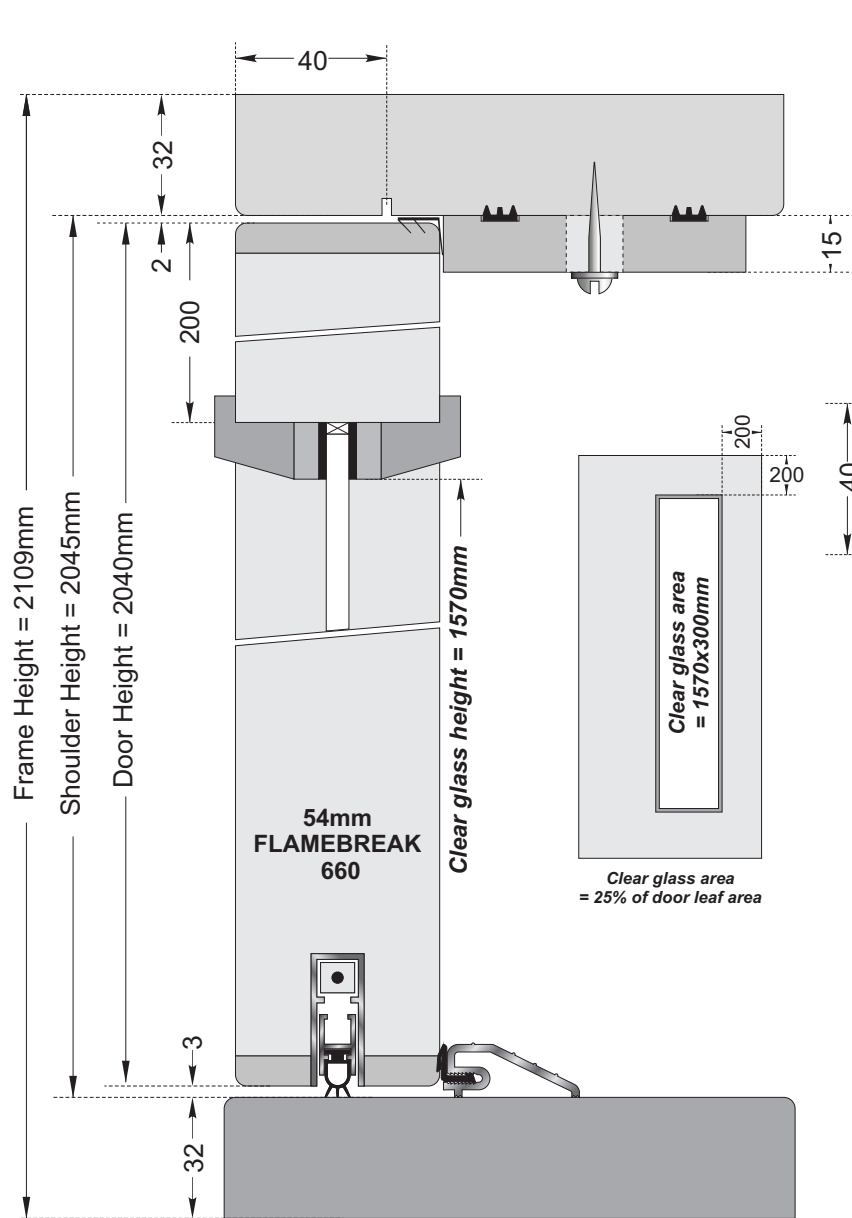

TEST 65b : Nom. 6mm Pyroshield glass. NORSOUND 710 to Head & Jambs.
NORSOUND 810 to Threshold used with modified NORSOUND 650
threshold strip. = **Rw.34dB. SRL Test 60.**

Dwg. Ref:	Sk/AHP/160208/T064		
TITLE	NORSOUND Acoustic Tests Test 65b FLAMEBREAK 660		
Scale	1 : 2	Date	16/6/08
Revisions			

Tony Palmer
Invented 2000

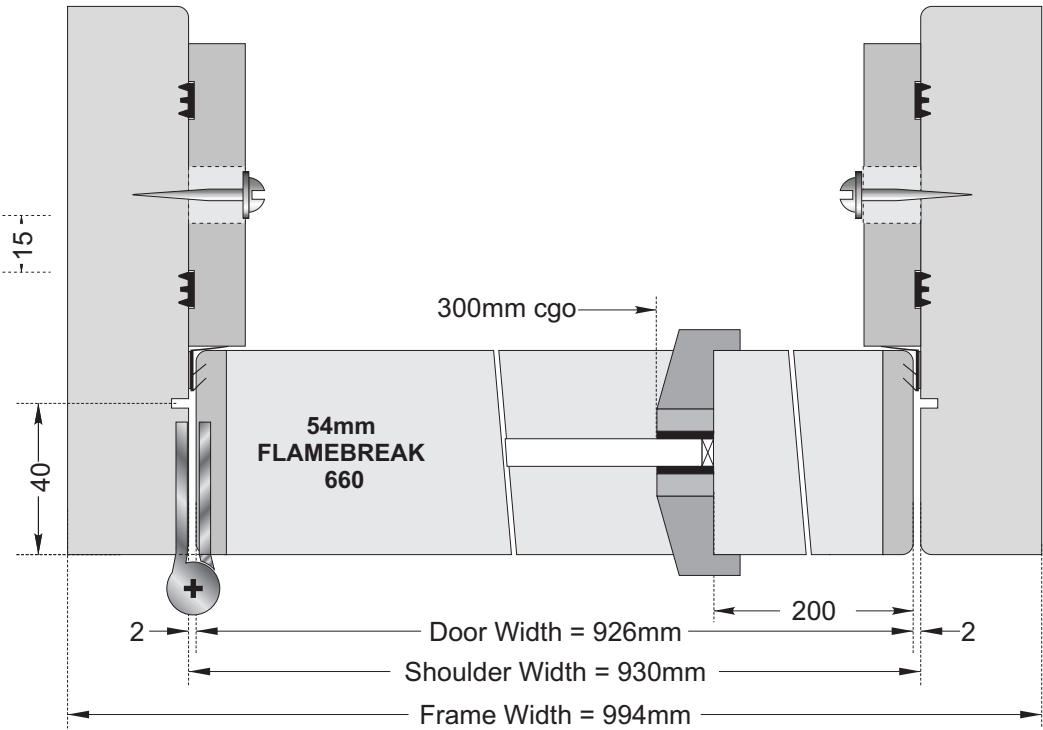
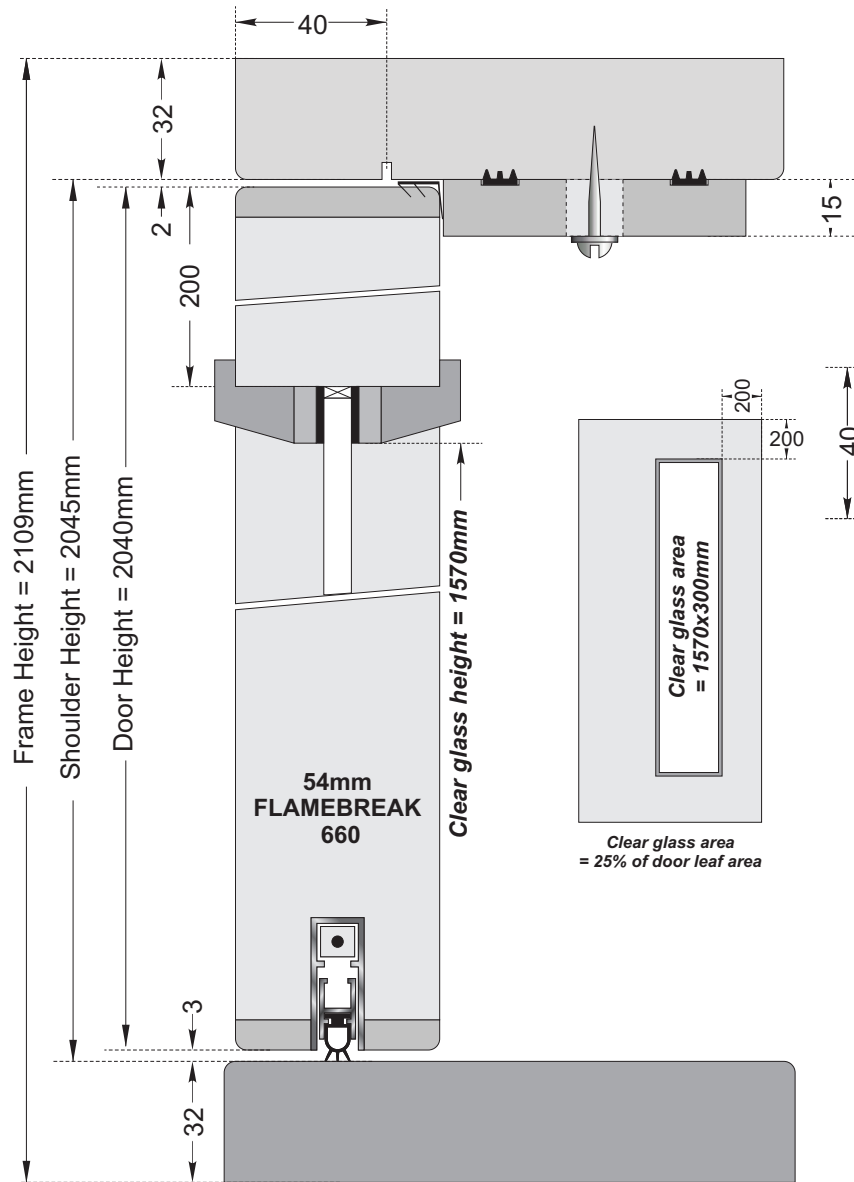

TEST 66 : Nom. 7mm Pyrobelite glass. NORSOUND 710 to Head & Jambs.
NORSOUND 810 to Threshold. = **Rw.34dB. SRL Test 34.**

Dwg. Ref:	Sk/AHP/160208/T065		
TITLE	NORSOUND Acoustic Tests Test 60c FLAMEBREAK 660		
Scale	1 : 2	Date	16/6/08
Revisions			

Tony Palmer
Invented 2000

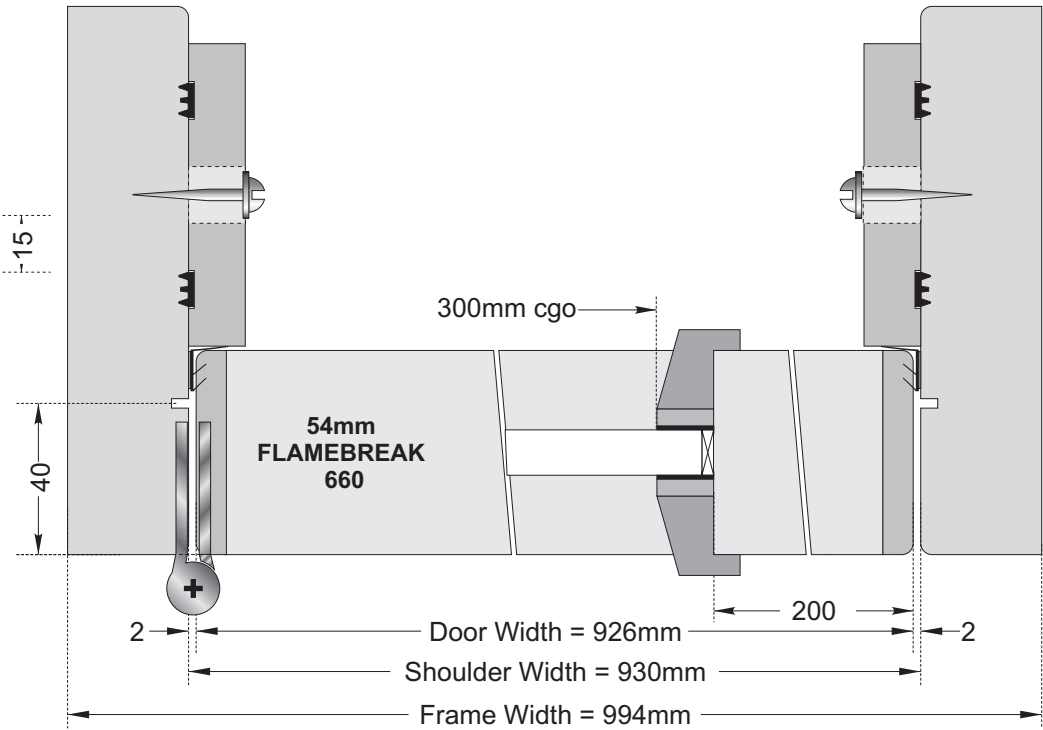
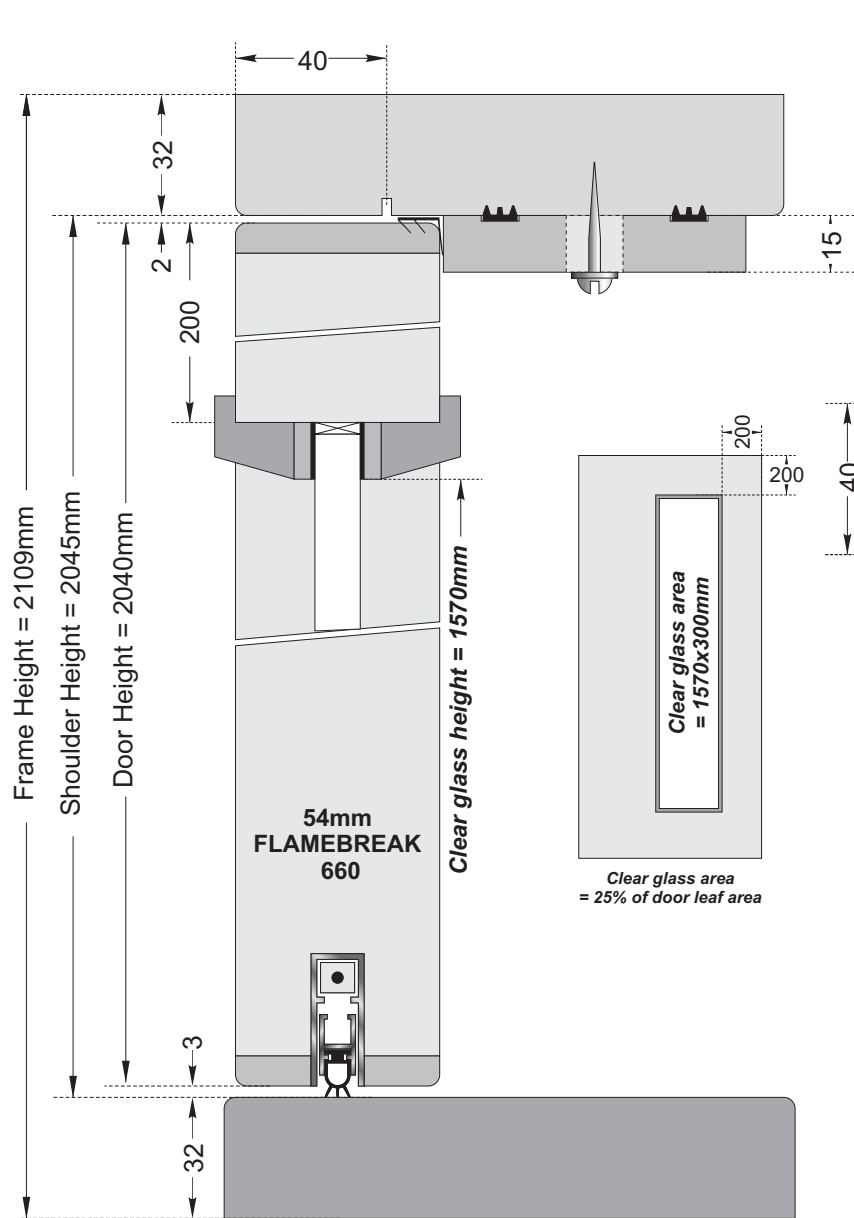

TEST 67a : Nom. 12mm Pyrobelite glass. NORSOUND 710 to Head & Jambs.
NORSOUND 810 to Threshold. = **Rw.34dB. SRL Test 35.**

TEST 67b : Nom. 12mm Pyrobelite glass. NORSOUND 710 to Head & Jambs.
NORSOUND 810 to Threshold. = **Rw.34dB. SRL Test 36.**

Dwg. Ref:	Sk/AHP/160208/T066		
TITLE	NORSOUND Acoustic Tests Test 67a & 67b FLAMEBREAK 660		
Scale	1 : 2	Date	16/6/08
Revisions			

Tony Palmer
Smartech 2000

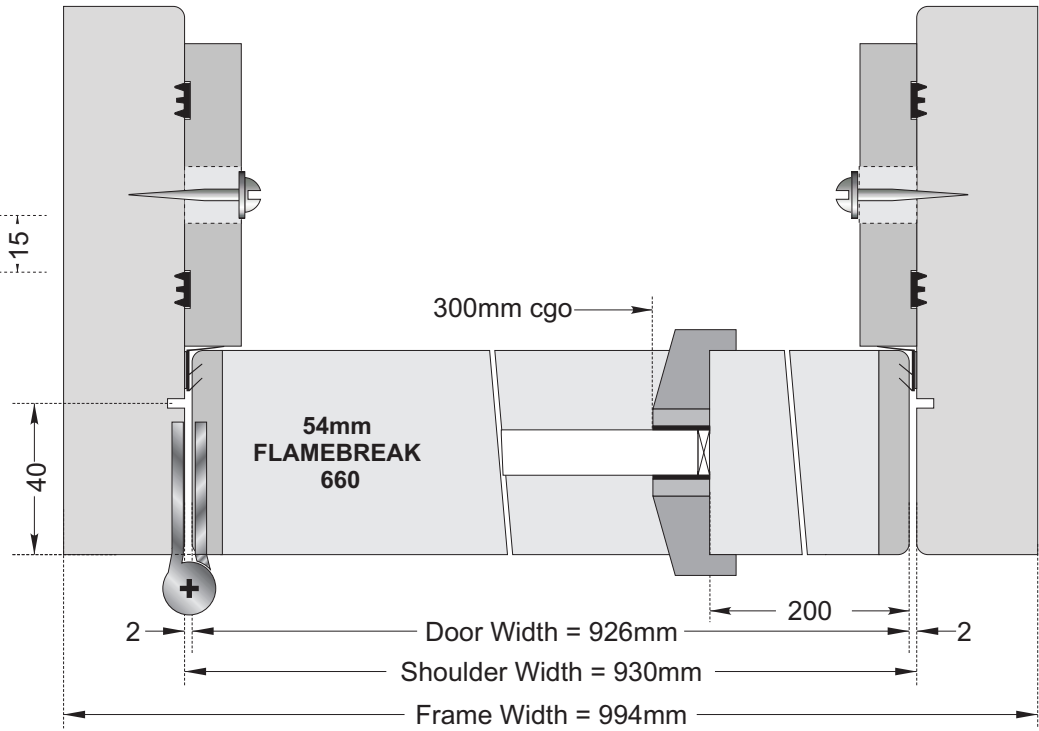
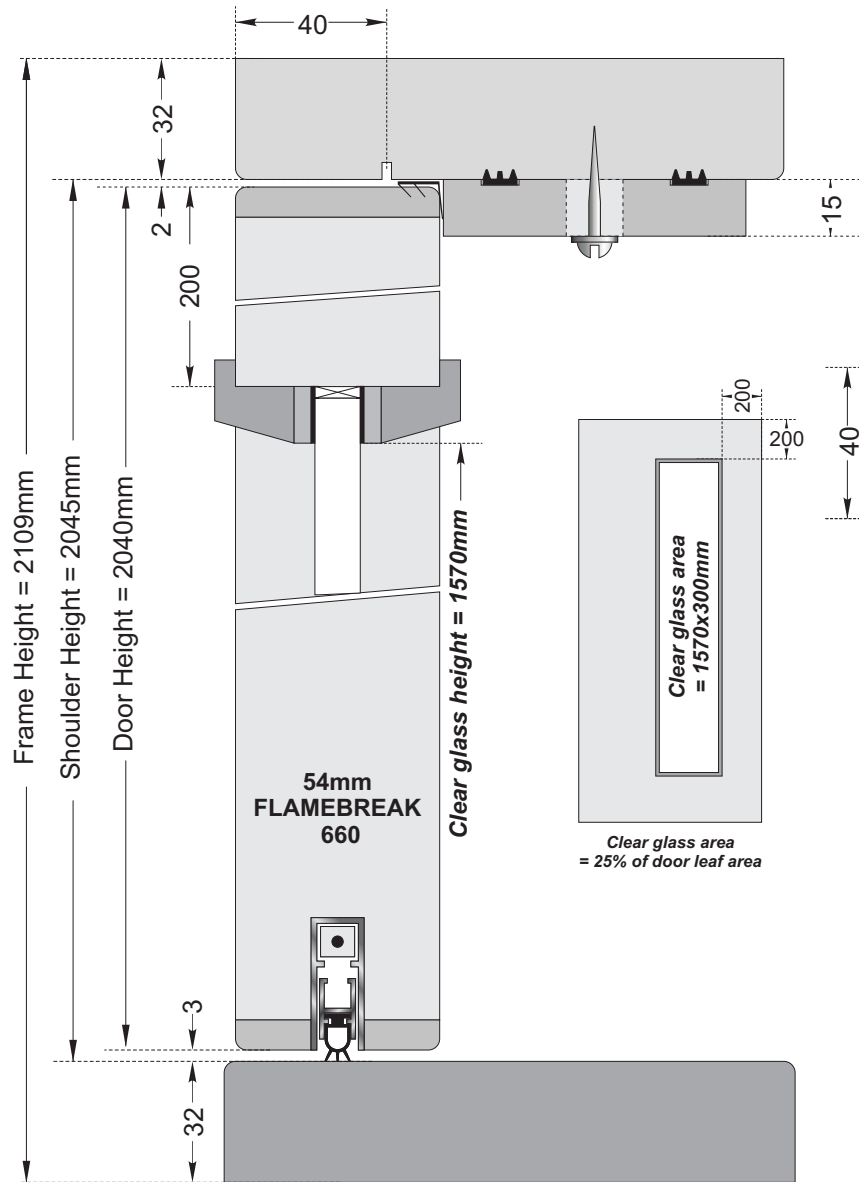

TEST 68a : Nom. 11.5mm 3 Ply PA Res. glass. NORSOUND 710 to Head & Jamb.
NORSOUND 810 to Threshold. = **Rw.34dB. SRL Test 38.**

Dwg. Ref:	Sk/AHP/160208/T067		
TITLE	NORSOUND Acoustic Tests Test 68a. FLAMEBREAK 660		
Scale	1 : 2	Date	16/6/08
Revisions			

Tony Palmer
Invented 2000

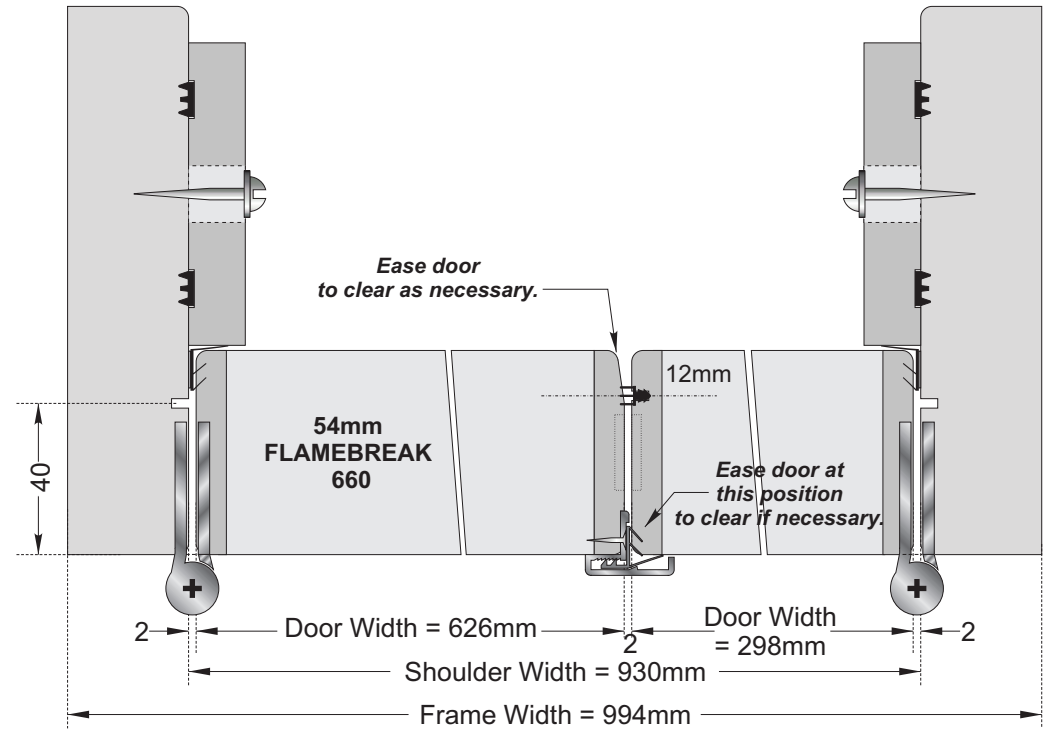
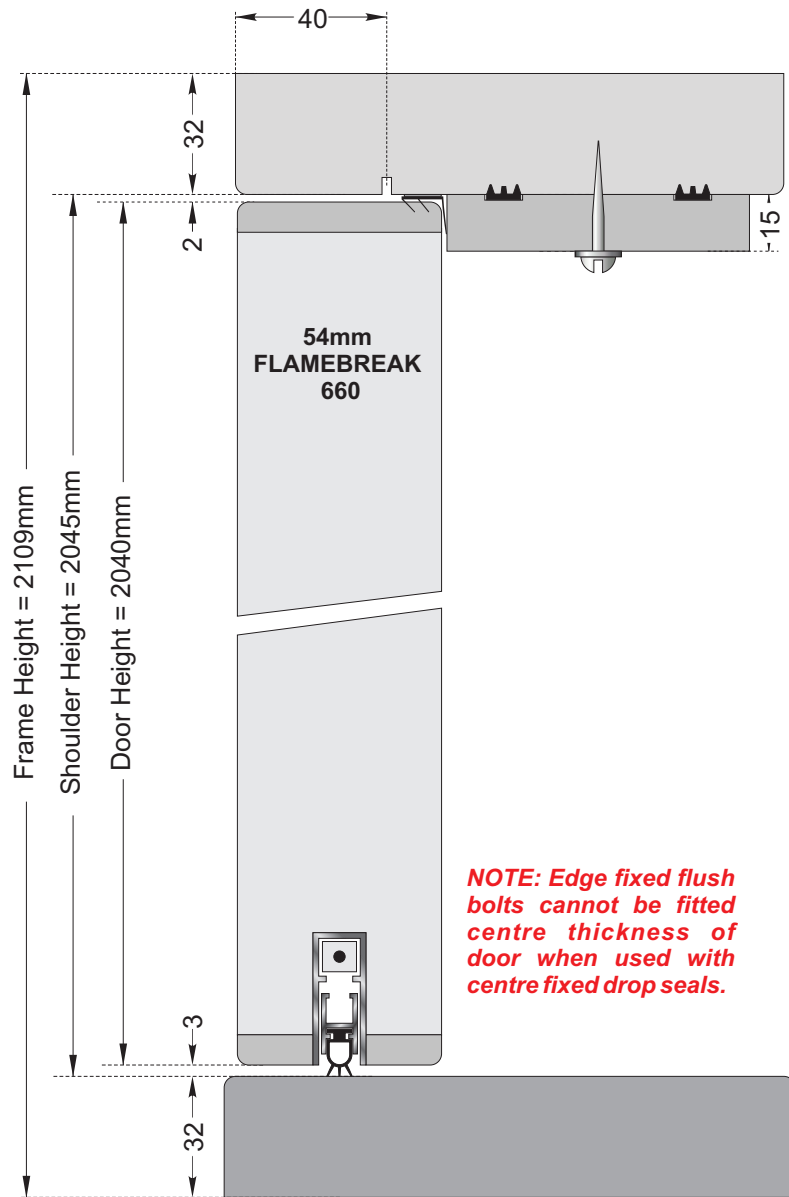

TEST 88: NORSOUND 710 to Head & Jambs + NORSOUND 810 to threshold of each door.
NORSOUND 720 and NORSOUND 510 at Meeting Stiles.
= Rw.34dB. SRL Test 82.

Dwg. Ref:	Sk/AHP/160208/T068		
TITLE	NORSOUND Acoustic Tests Test 88 FLAMEBREAK 660		
Scale	1 : 2	Date	16/6/08
Revisions			

Tony Palmer
Invented 2000

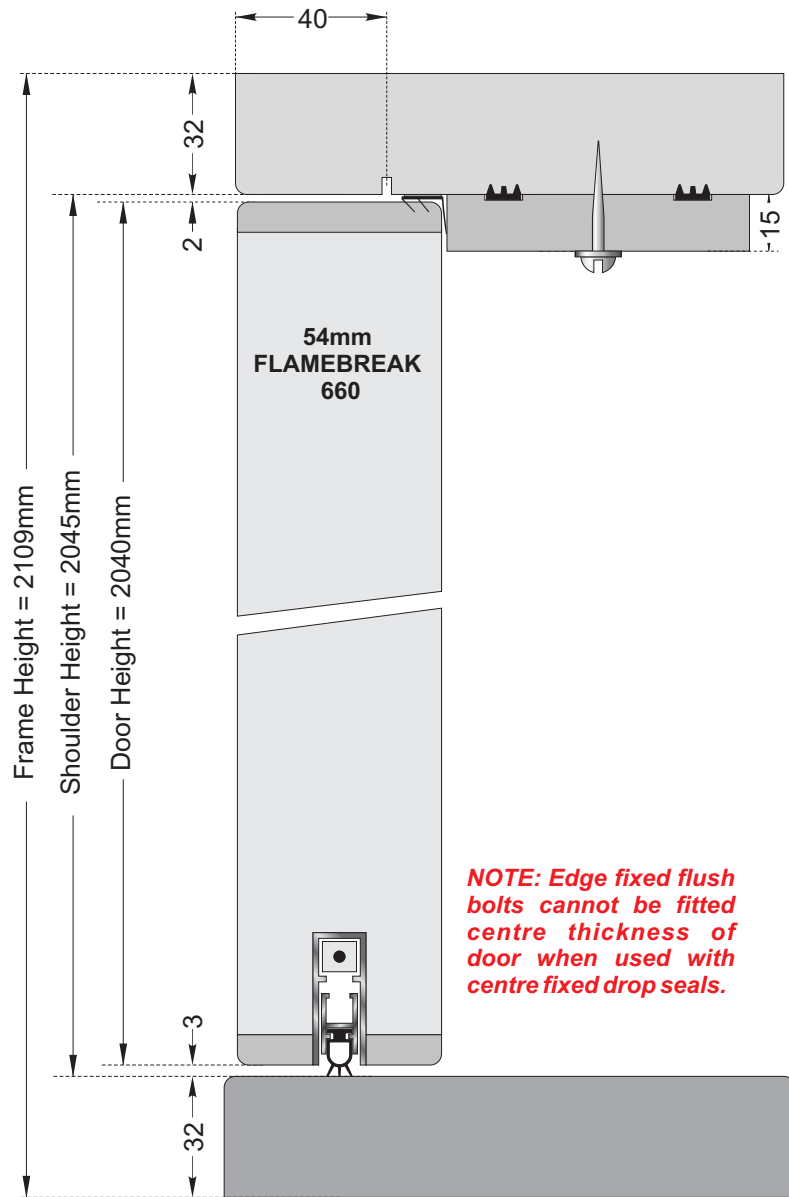

NOTE: Edge fixed flush bolts cannot be fitted centre thickness of door when used with centre fixed drop seals.

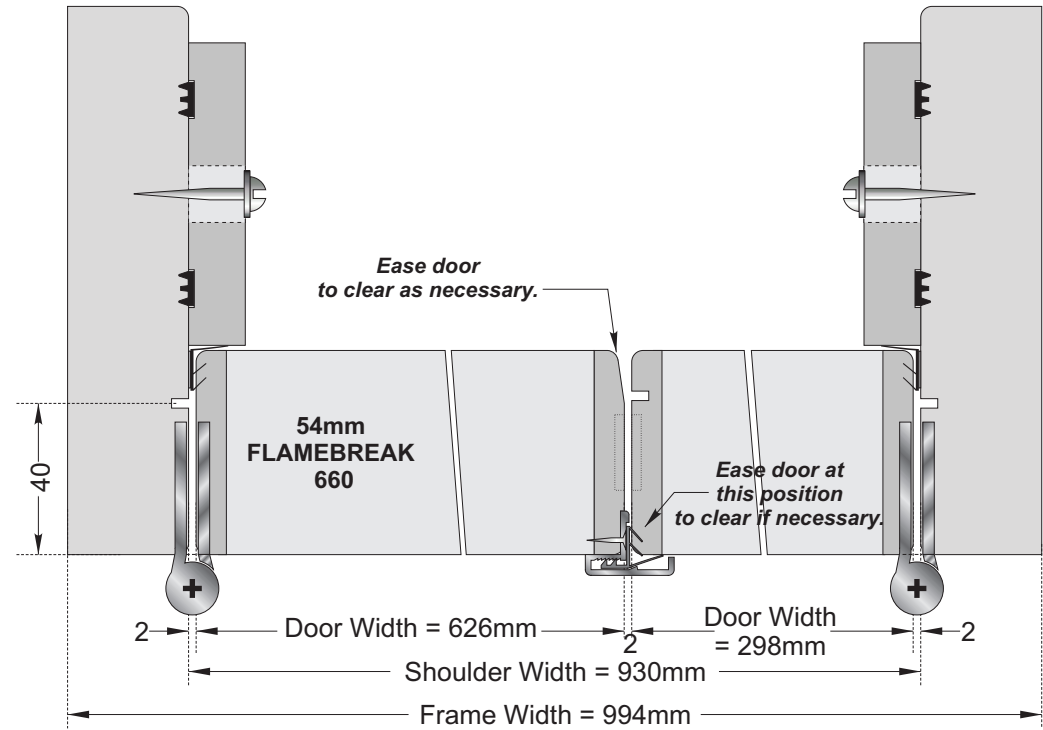

TEST 88a: NORSOUND 710 to Head & Jambs + NORSOUND 810 to threshold of each door. NORSOUND 510 at Meeting Stiles. = **Rw.33dB. SRL Test 83.**

Dwg. Ref:	Sk/AHP/160208/T069		
TITLE	NORSOUND Acoustic Tests Test 88a FLAMEBREAK 660		
Scale	1 : 2	Date	16/6/08
Revisions			

Tony Palmer
Invented 2000

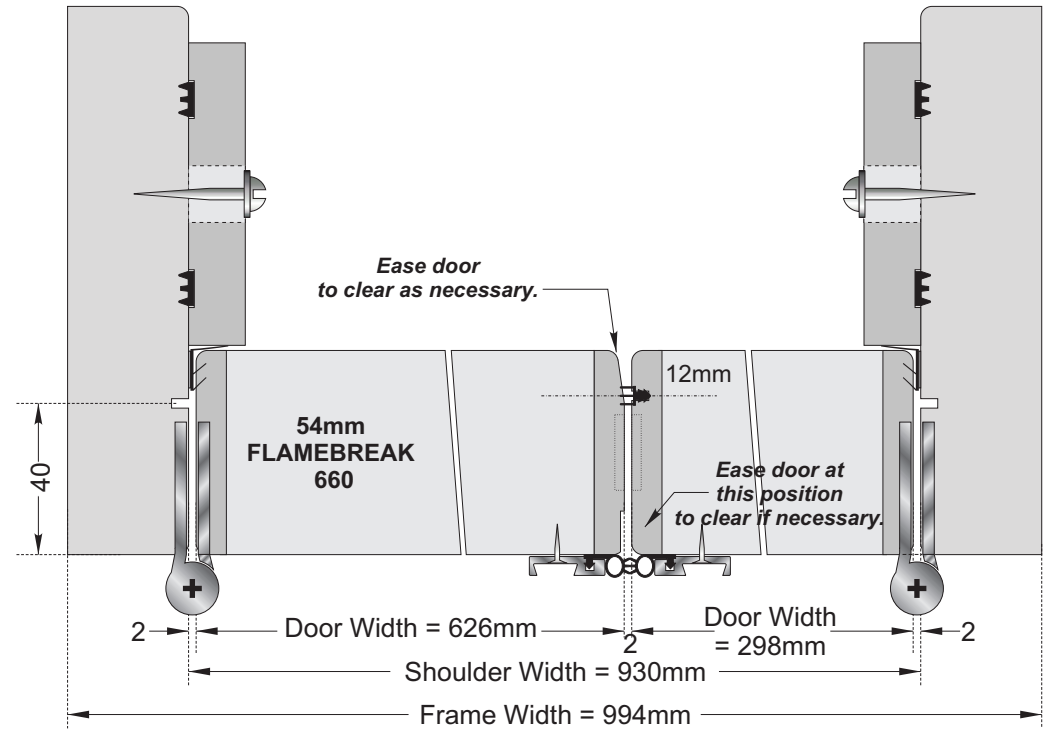
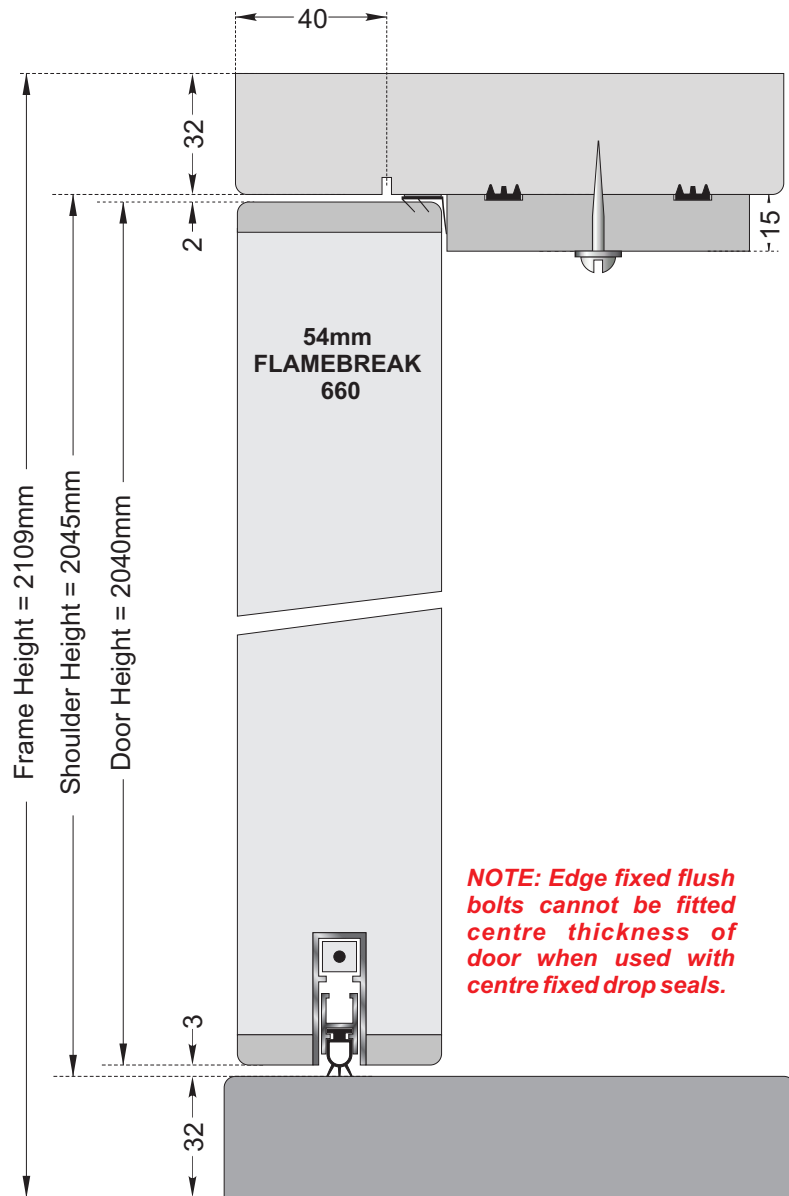

TEST 89: NORSOUND 710 to Head & Jambs + NORSOUND 810 to threshold of each door.
NORSOUND 720 and 2No. NORSOUND 755 at Meeting Stiles.
= Rw.34dB. SRL Test 84.

Dwg. Ref:	Sk/AHP/160208/T070		
TITLE	NORSOUND Acoustic Tests Test 89 FLAMEBREAK 660		
Scale	1 : 2	Date	16/6/08
Revisions			

Tony Palmer
Invented 2000

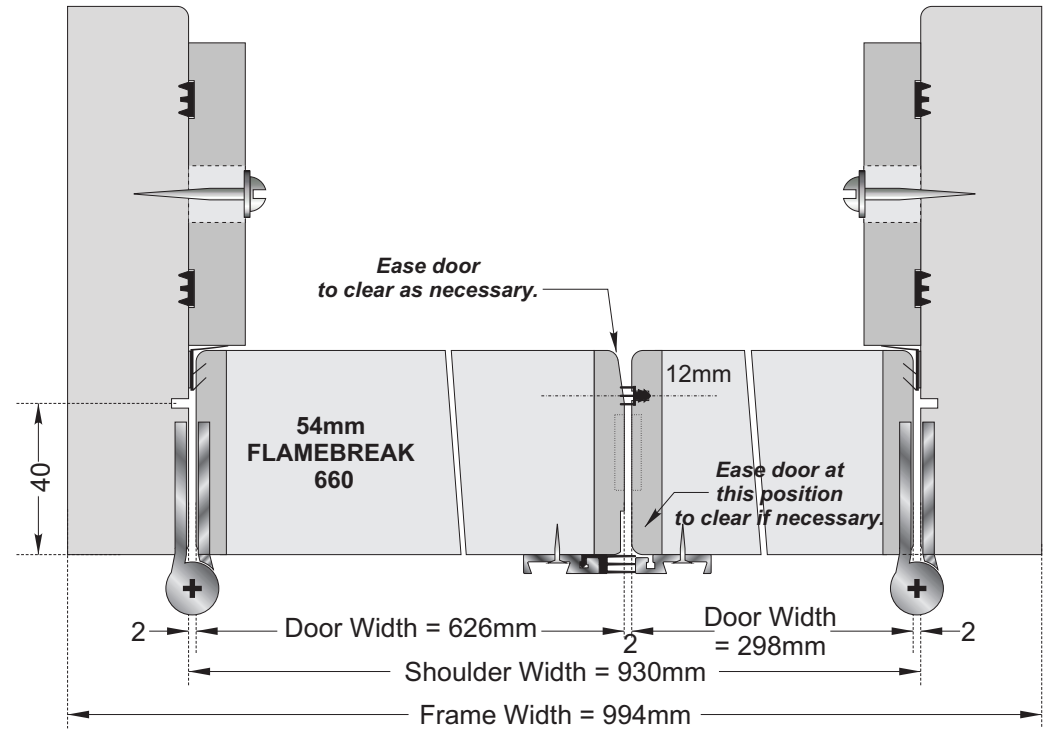
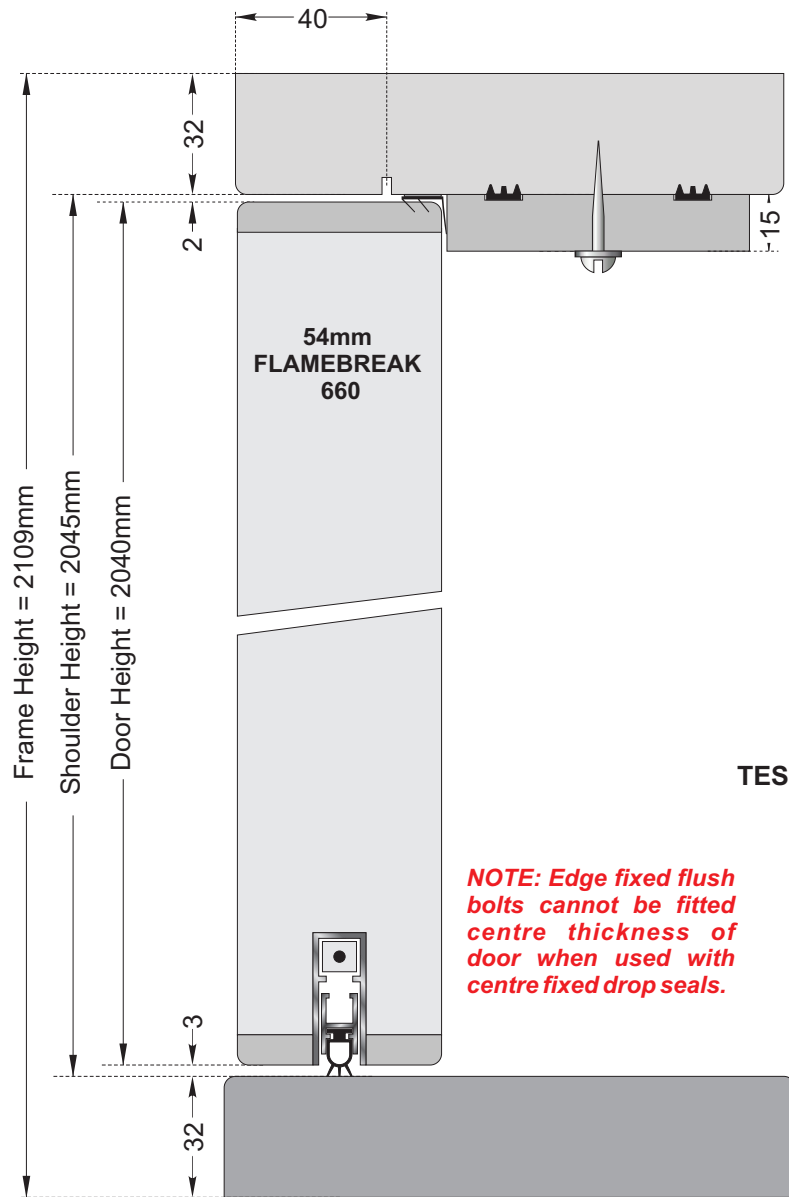

TEST 90: NORSOUND 710 to Head & Jams + NORSOUND 810 to threshold of each door.
NORSOUND 855 + NORSOUND 855 Carrier only + NORSOUND 720 at Meeting Stiles.
= **Rw.34dB. SRL Test 85.**

Dwg. Ref:	Sk/AHP/160208/T071		
TITLE	NORSOUND Acoustic Tests Test 90 FLAMEBREAK 660		
Scale	1 : 2	Date	16/6/08
Revisions			

Tony Palmer
Invented 2000

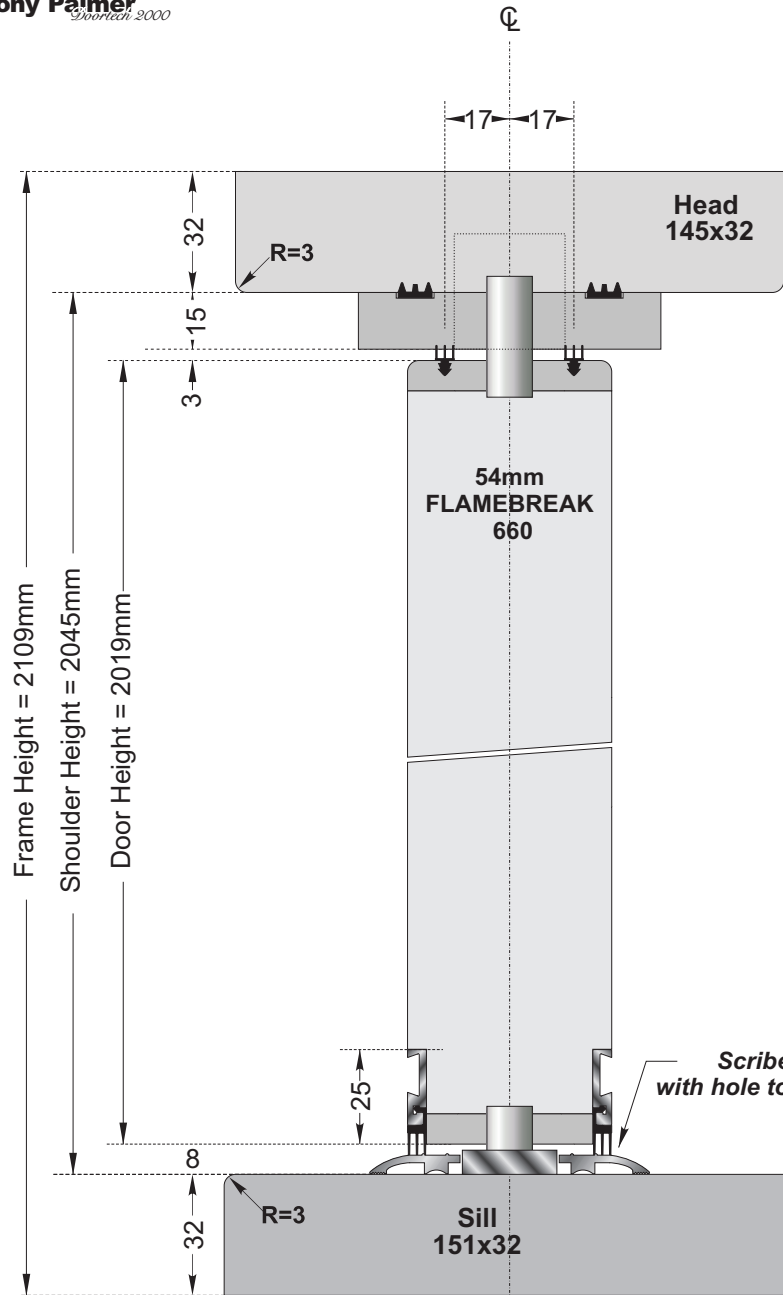

NOTE: At saddle scallop, scribe threshold to suit OR use filler to fill gap.

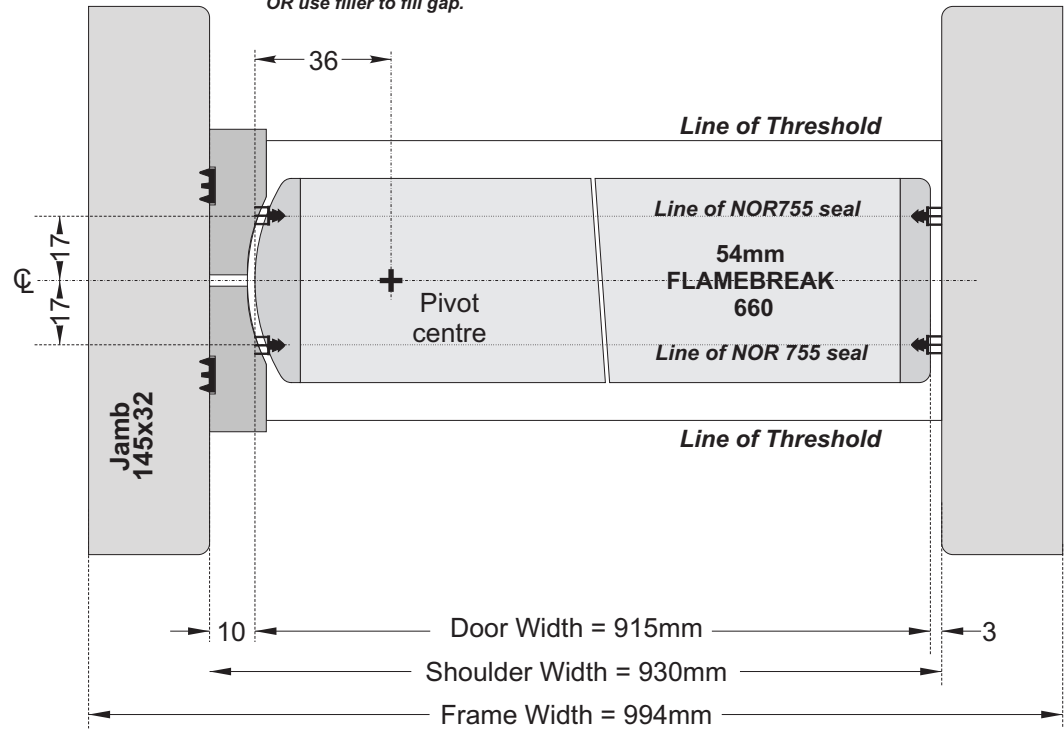

TEST 101a: Fully Caulked Double Action. = **Rw.33dB. SRL Test 104.**

TEST 101: Twin row NORSOUND 720 to Jamb & Head. Twin NORSOUND 855 seals recessed into face at the bottom of the door used with NORSOUND 620 Threshold plate scribed to suit R&T 36mm centre pivot fixings = **Rw.30dB. SRL Test 105.**

Dwg. Ref:	Sk/AHP/160208/T072		
TITLE	NORSOUND Acoustic Tests Test 101 & 101a FLAMEBREAK 660		
Scale	1 : 2	Date	16/6/08
Revisions			

Tony Palmer
Invented 2000

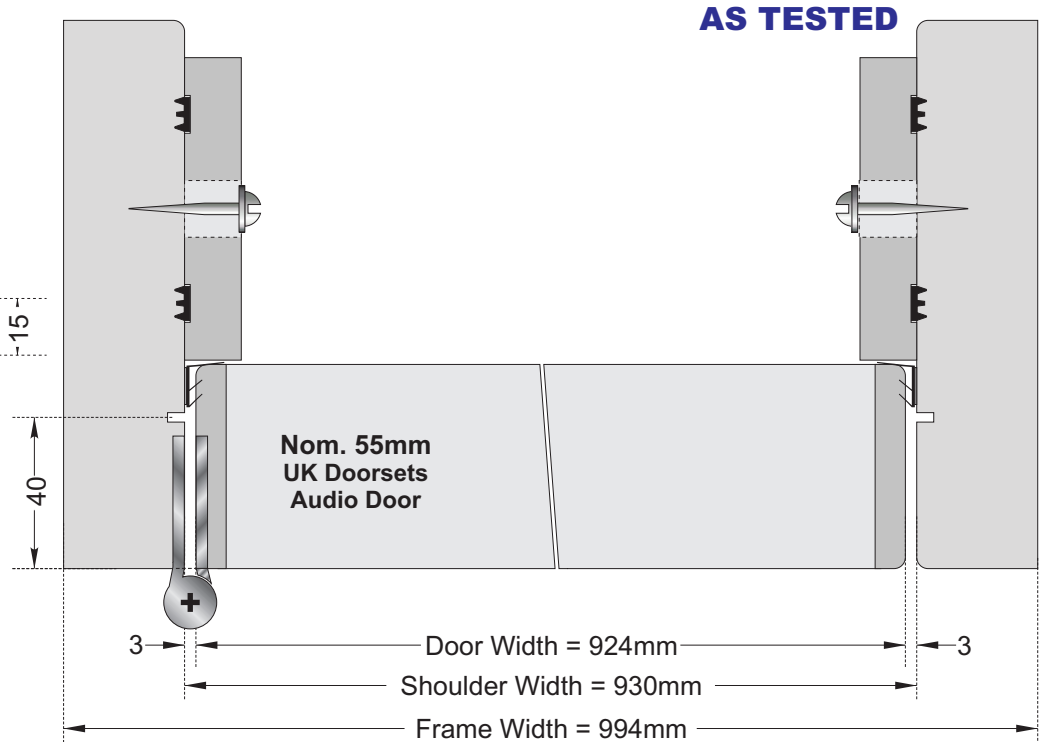
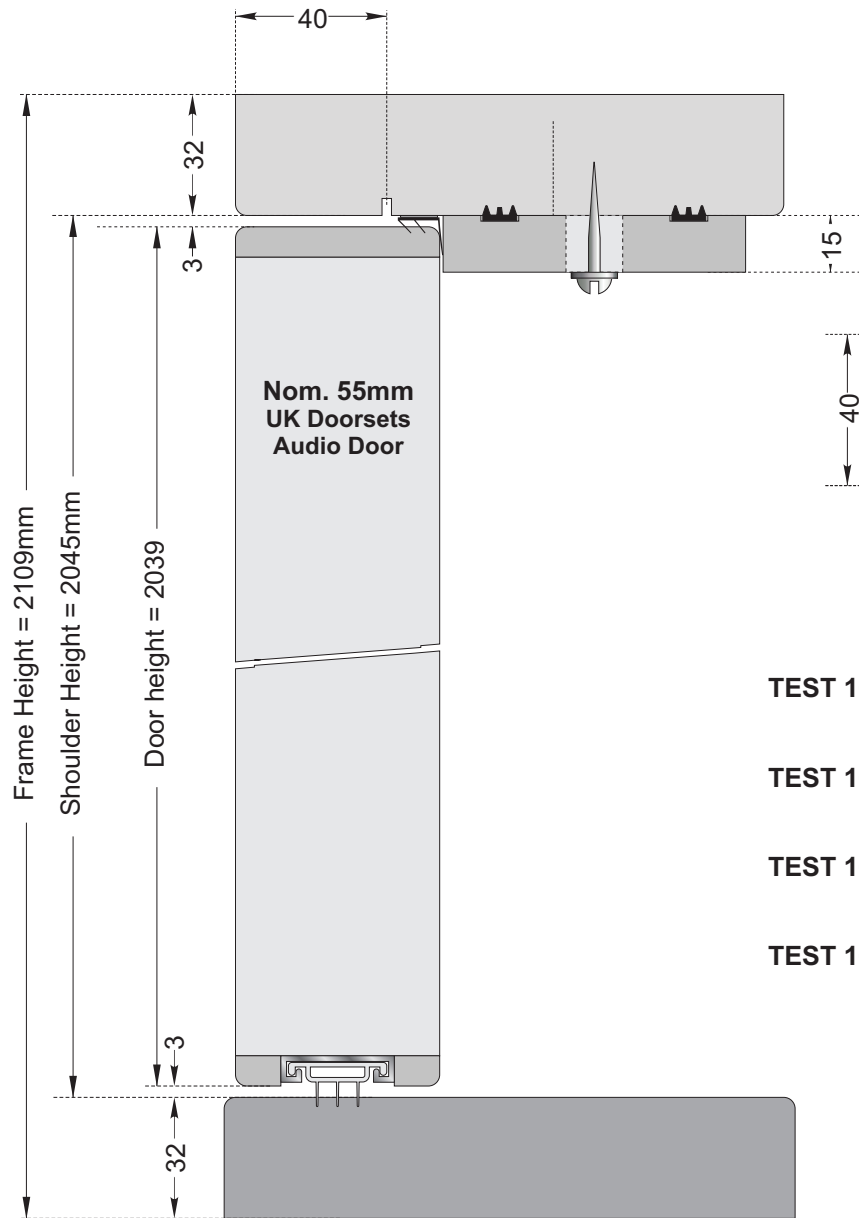

TEST 105: Audiocore Door. Fully Caulk Test.
= **Rw.42dB. SRL Test 92.**

TEST 106: Audiocore Door with NOR SOUND 710 to Jambs & Head with NOR SOUND 850 to threshold. = **Rw.36dB. SRL Test 93.**

TEST 106a: Audiocore Door with NOR SOUND 710 to Jambs & Head with NOR SOUND 850 to threshold. = **Rw.36dB. SRL Test 95.**

TEST 106b: Audiocore Door with NOR SOUND 710 to Jambs & Head with NOR SOUND 850 to threshold. = **Rw.37dB. SRL Test 96.**

Dwg. Ref:	Sk/AHP/160208/T073		
TITLE	NOR SOUND Acoustic Tests Test 105, 106, 106a, 106b AUDIOCORE		
Scale	1 : 2	Date	16/6/08
Revisions			

Tony Palmer
Invented 2000

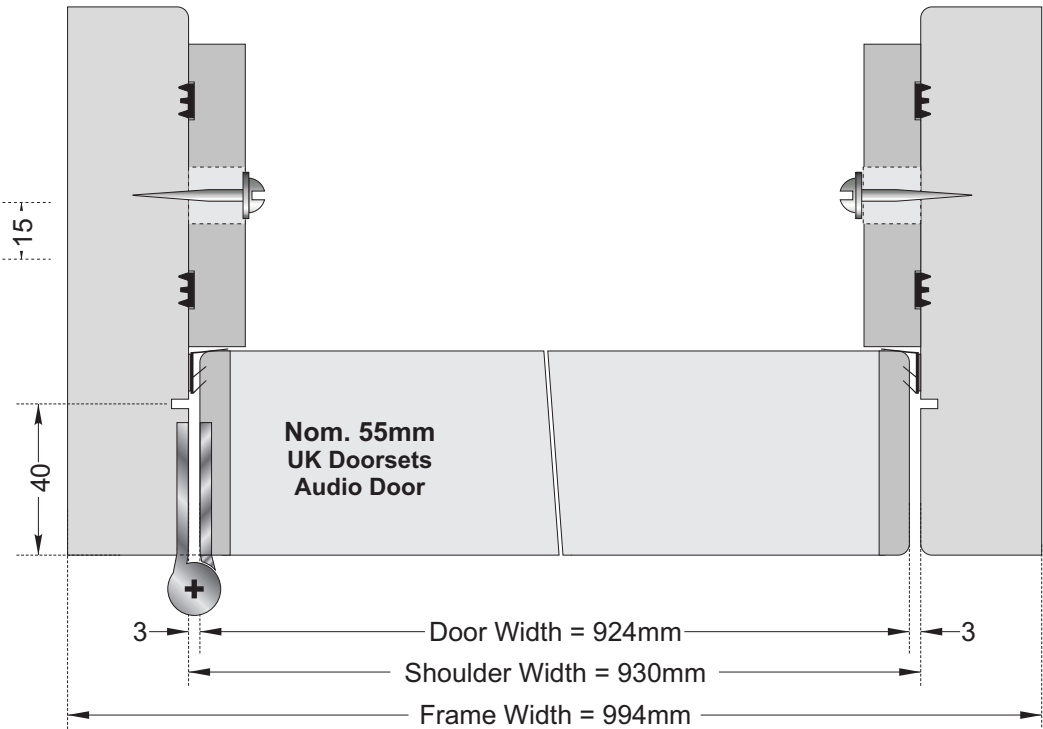
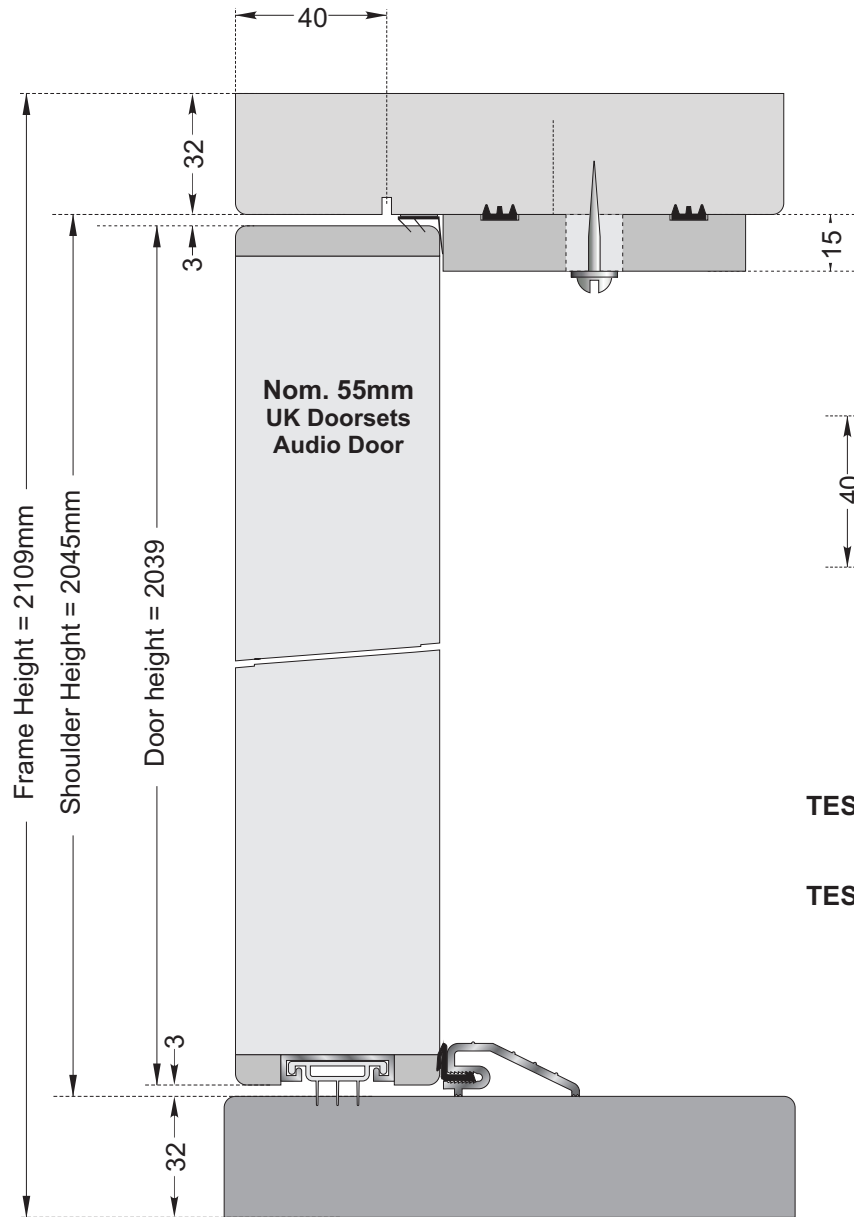

TEST 107: Audiocore Door with NORSOUND 710 to Jambs & Head with NORSOUND 850 use with modified NORSOUND 650 = **Rw.41dB. SRL Test 97.**

TEST 110: Audiocore Door with NORSOUND 710 to Jambs & Head with NORSOUND 850 use with modified NORSOUND 650 = **Rw.41dB. SRL Test 100.**

Dwg. Ref:	Sk/AHP/160208/T074		
TITLE	NORSOUND Acoustic Tests Test 107 & 110 AUDIOCORE		
Scale	1 : 2	Date	16/6/08
Revisions			

Tony Palmer
Invented 2000

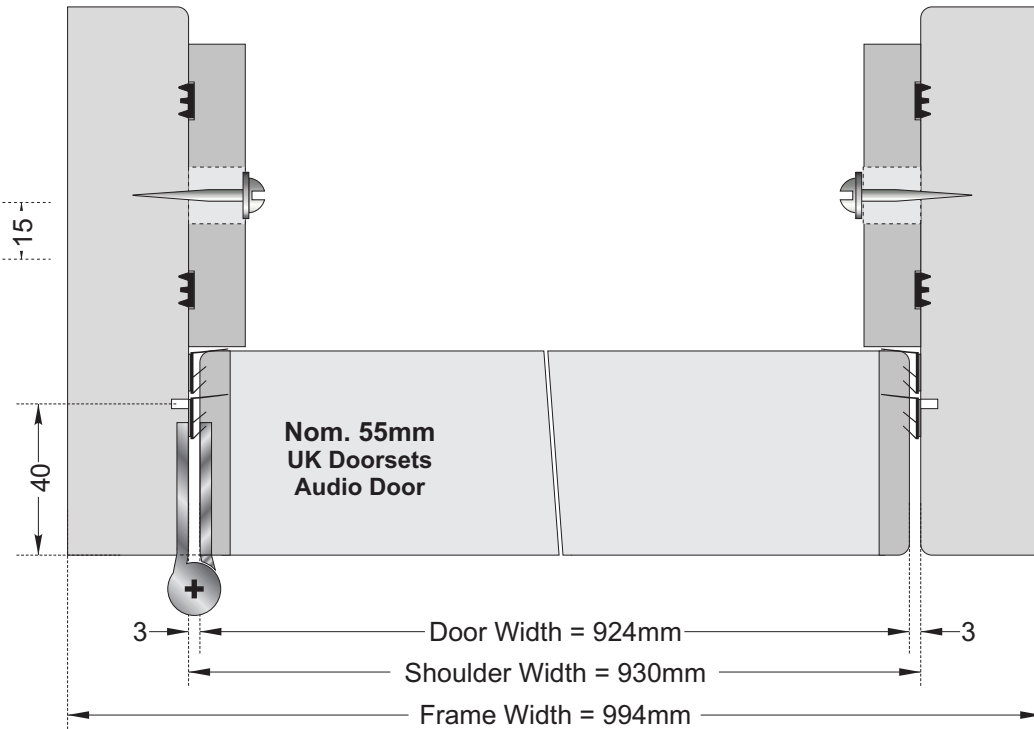
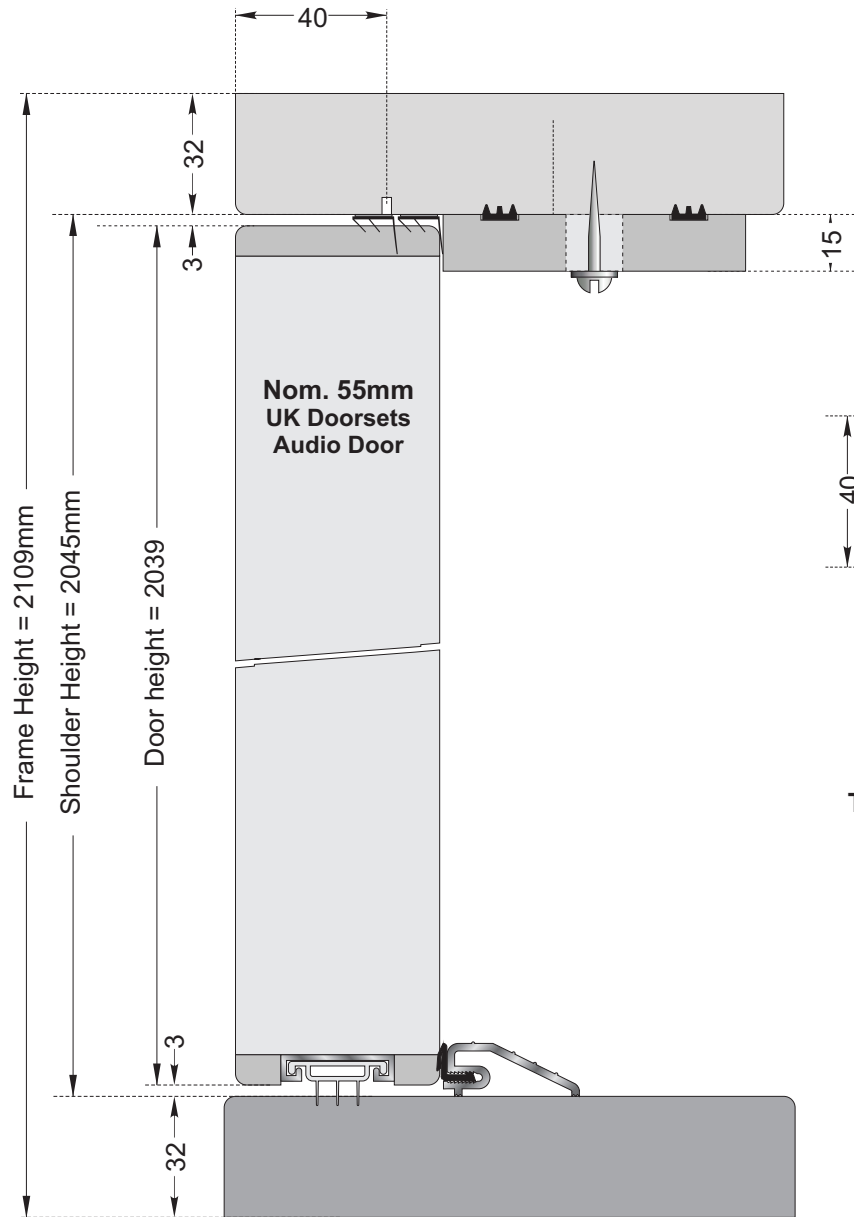

TEST 108: Audiocore Door with 2 No. NOR SOUND 710 to Jambs & Head with NOR SOUND 850 use with modified NOR SOUND 650 = **Rw.42dB. SRL Test 108.**

Dwg. Ref:	Sk/AHP/160208/T075		
TITLE	NOR SOUND Acoustic Tests Test 108 AUDIOCORE		
Scale	1 : 2	Date	16/6/08
Revisions			

Tony Palmer
Smartech 2000

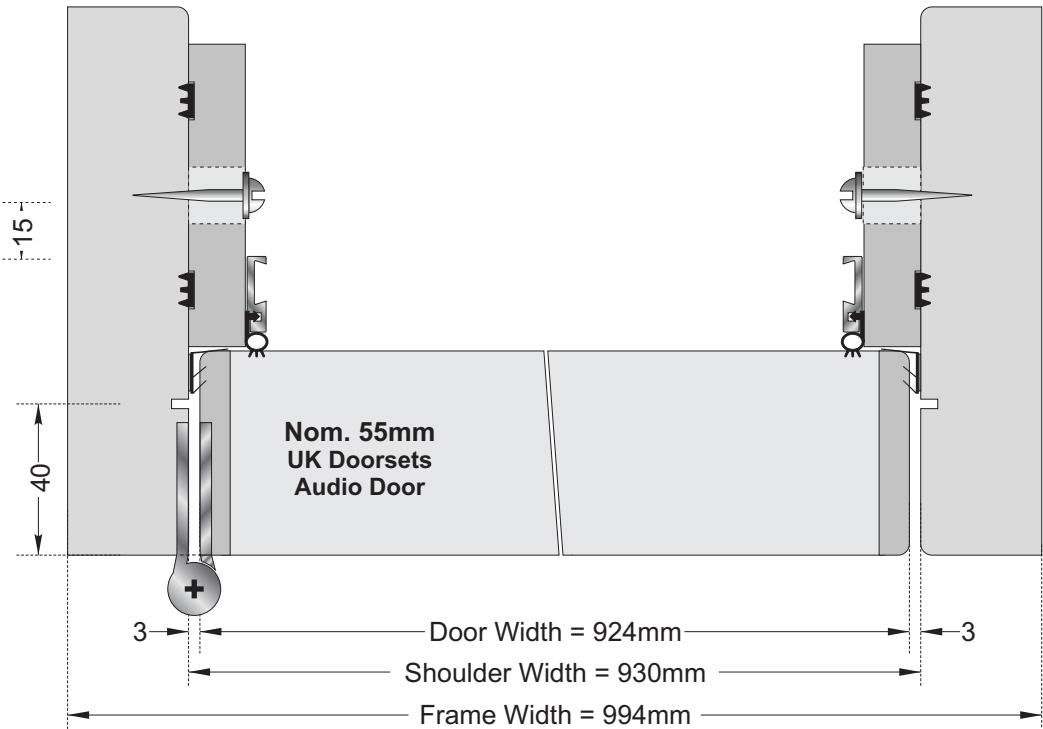
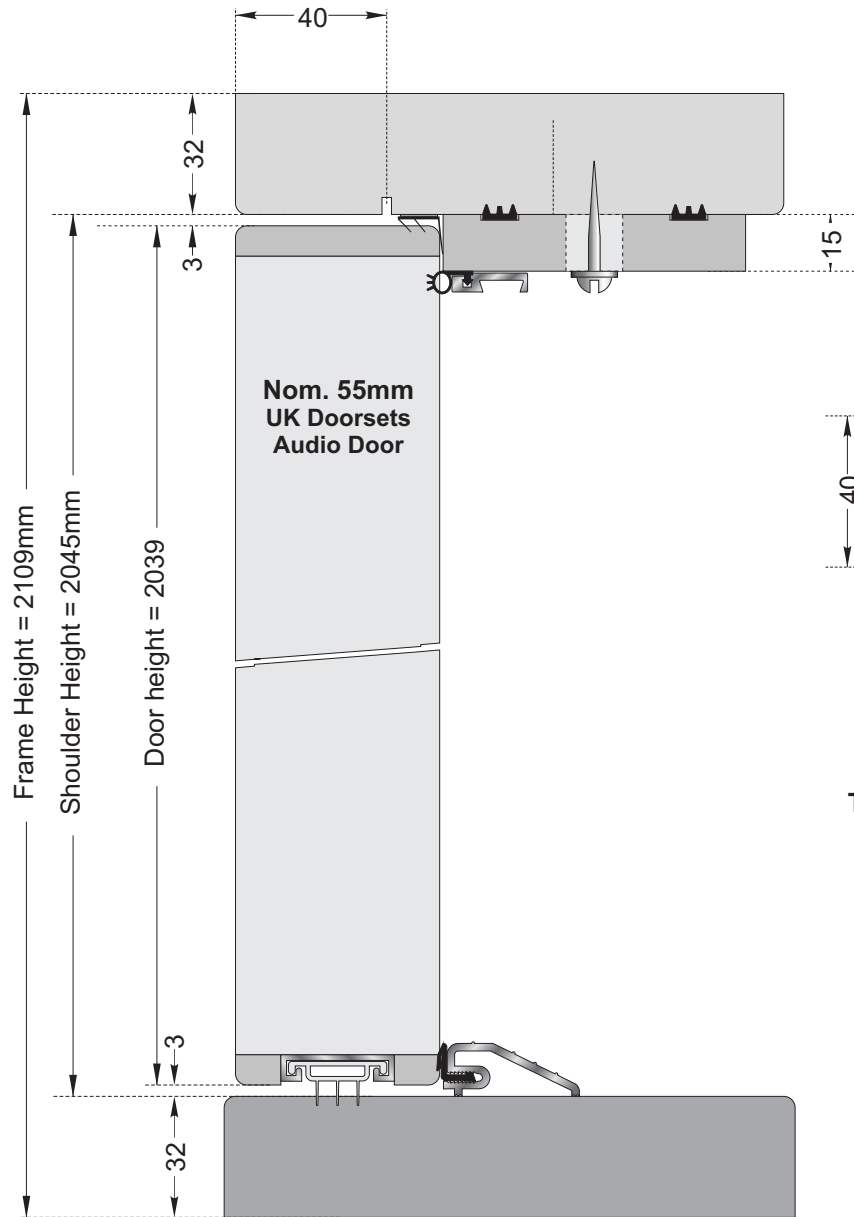

TEST 109: Audiocore Door with NOR SOUND 710 + NOR SOUND 755 to Jambs & Head with NOR SOUND 850 use with modified NOR SOUND 650 = **Rw.42dB. SRL Test 99.**

Dwg. Ref:	Sk/AHP/160208/T076		
TITLE	NOR SOUND Acoustic Tests Test 109 AUDIOCORE		
Scale	1 : 2	Date	16/6/08
Revisions			

Tony Palmer
Smartech 2000

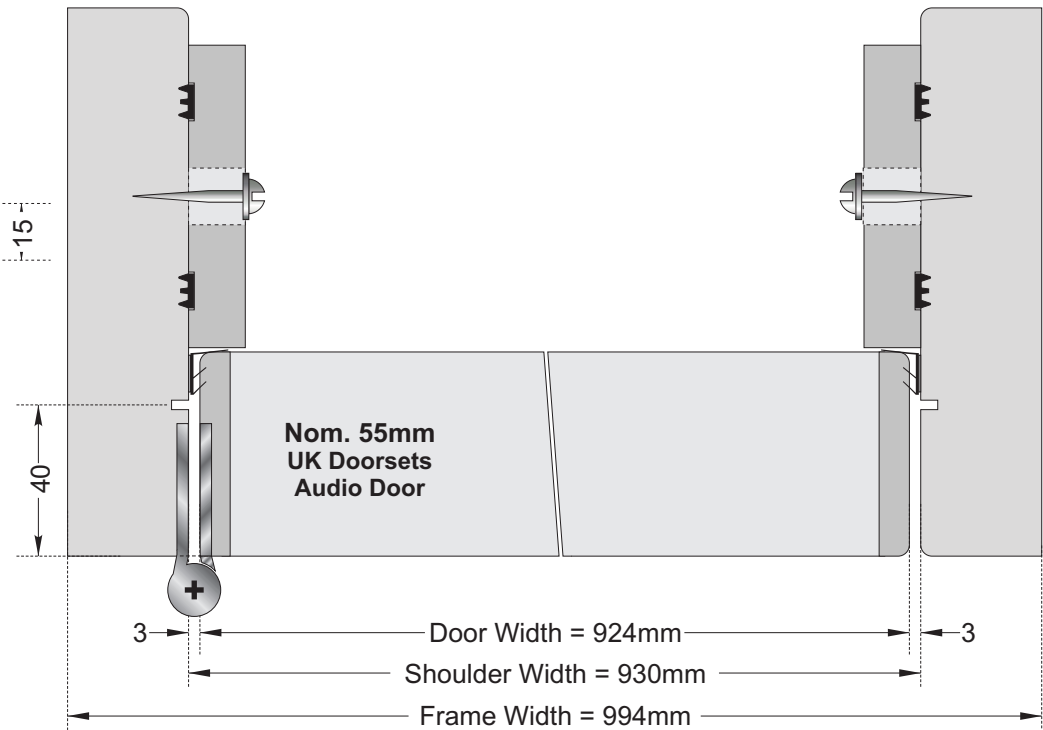
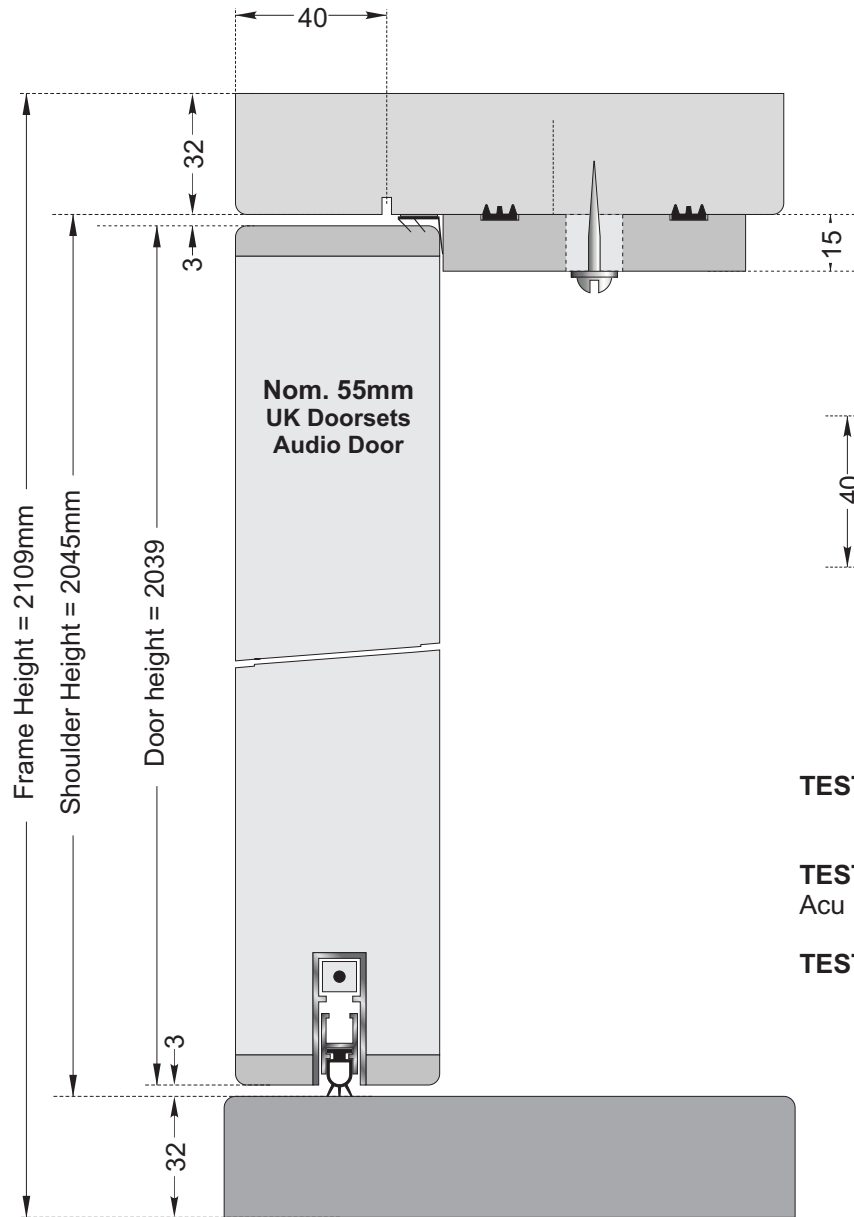

TEST 111: Audiocore Door with NORSOUND 710 to Jambs & Head with NORSOUND 810. = **Rw.38dB. SRL Test101.**

TEST 112: Audiocore Door with NORSOUND 710 to Jambs & Head with NORSOUND 810 Acu Pads added at drop seal position. = **Rw.38dB. SRL Test102.**

TEST 113: Audiocore Door Fully Caulked Test = **Rw.42dB. SRL Test103.**

Dwg. Ref:	Sk/AHP/160208/T077		
TITLE	NORSOUND Acoustic Tests Test 111,112 & 113 AUDIOCORE		
Scale	1 : 2	Date	16/6/08
Revisions			

Tony Palmer
Invented 2000

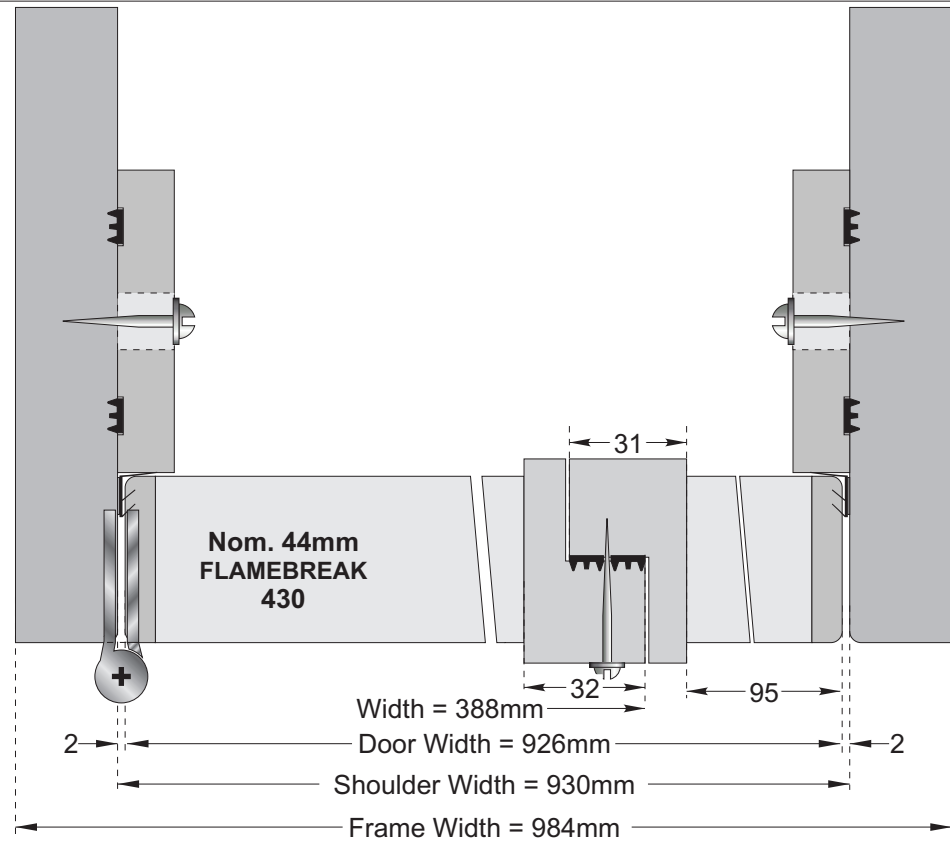
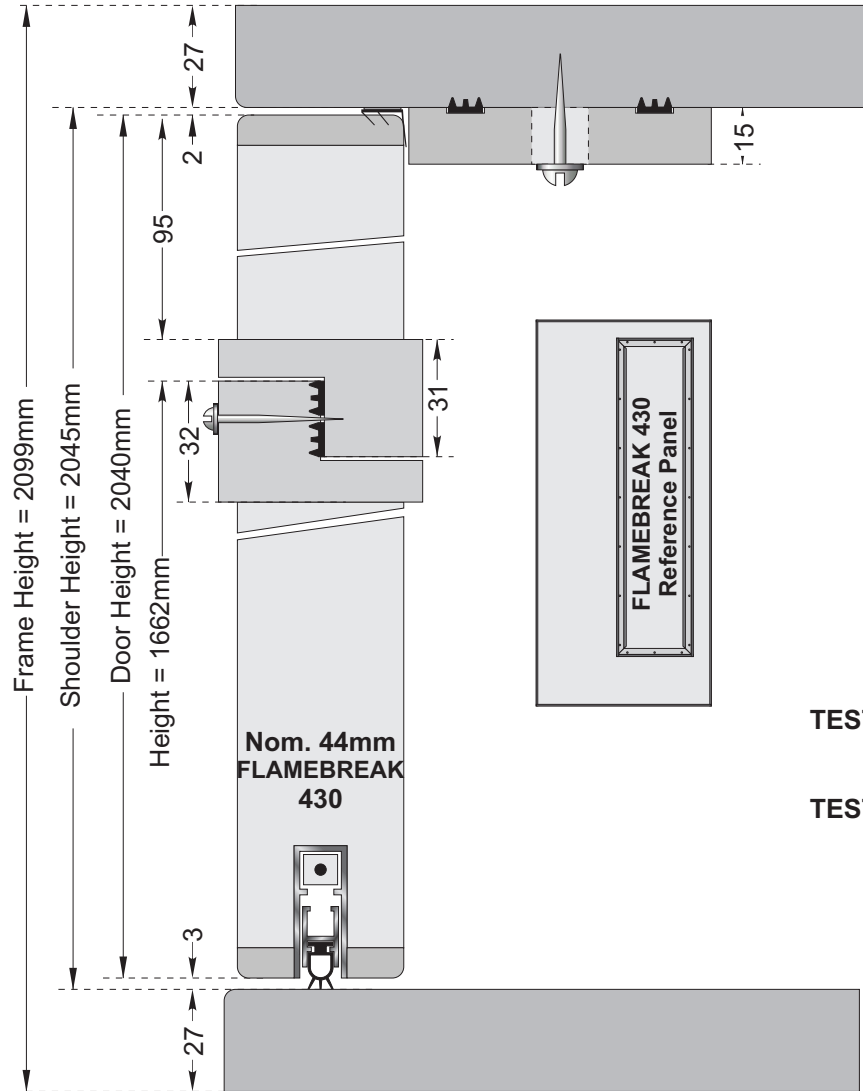

TEST 1: FLAMEBREAK 430 with FLAMEBREAK 430 solid panel fully caulked test.
Norsound Test July 2008 / 1 = SRL Test 115 = Rw.32dB

TEST 2: As Test 1 with NORSOUND 710 to Head & Jambs & NORSOUND 810 to Threshold.
Norsound Test July 2008 / 2 = SRL Test 116 = Rw.31dB

NOTE: See GLAZING TEST DETAILS Ref. Sk/AHP/260608/G001 ~ G009.

Dwg. Ref:	Sk/AHP/260608/T001		
TITLE	NORSOUND Acoustic Tests Tests 1 & 2 AS TESTED		
Scale	1 : 2	Date	26/6/08
Revisions			

Tony Palmer
Doortech, 2000

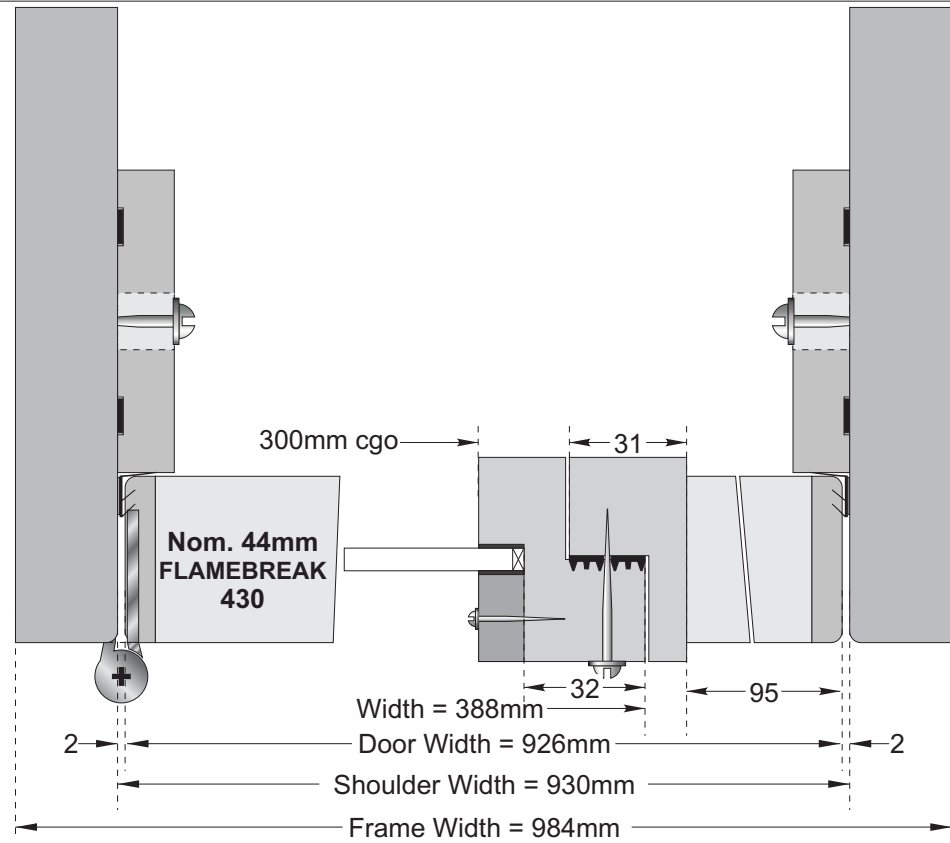
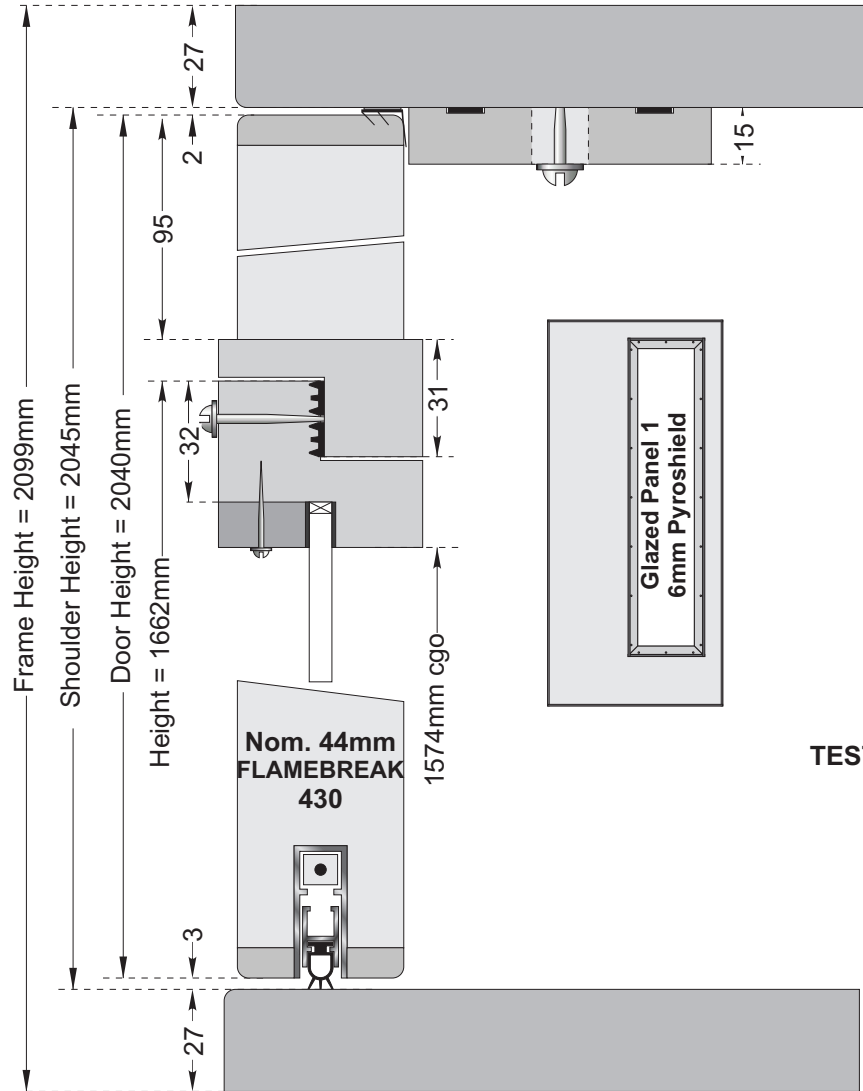

TEST 3: As Test 2 but; replace FLAMEBREAK 430 reference panel with GLAZED PANEL 1
Nom. 6mm Pyroshield glass.

Norsound Test July 2008 / 3 = SRL Test 117 = Rw.32dB

NOTE: See **GLAZING TEST DETAILS** Ref. Sk/AHP/260608/G001 ~ G010.

Dwg. Ref:	Sk/AHP/260608/T002		
TITLE	NORSOUND Acoustic Tests Test 3 AS TESTED		
Scale	1 : 2	Date	26/6/08
Revisions			

Tony Palmer
Doortech 2000

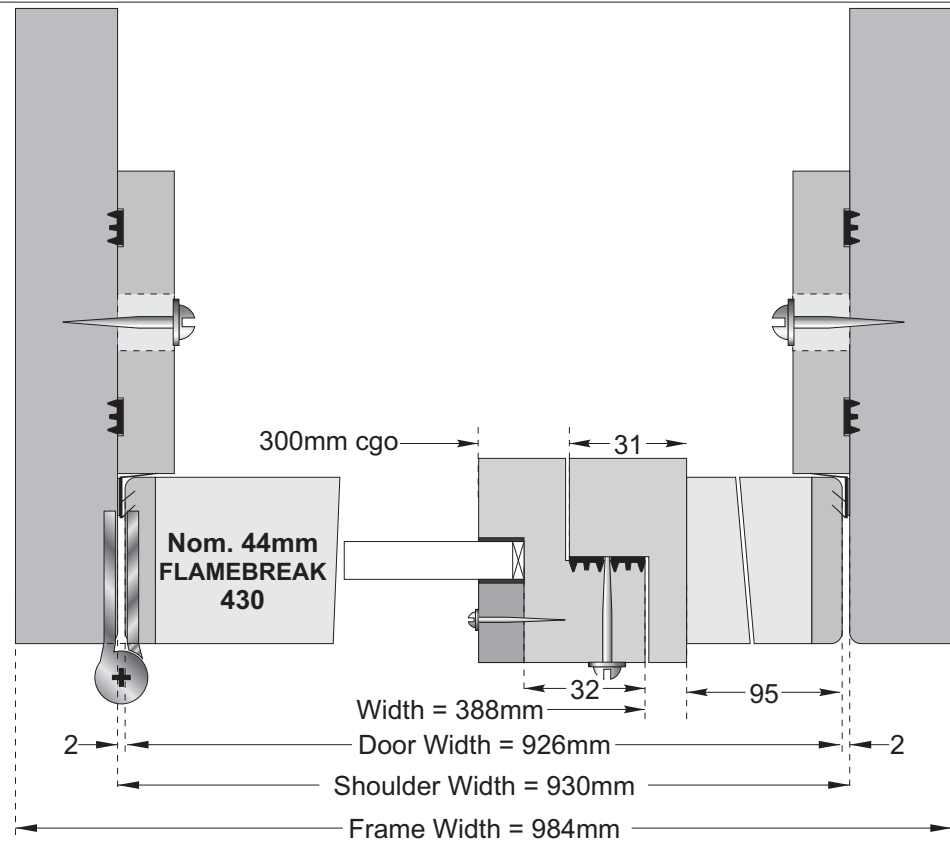
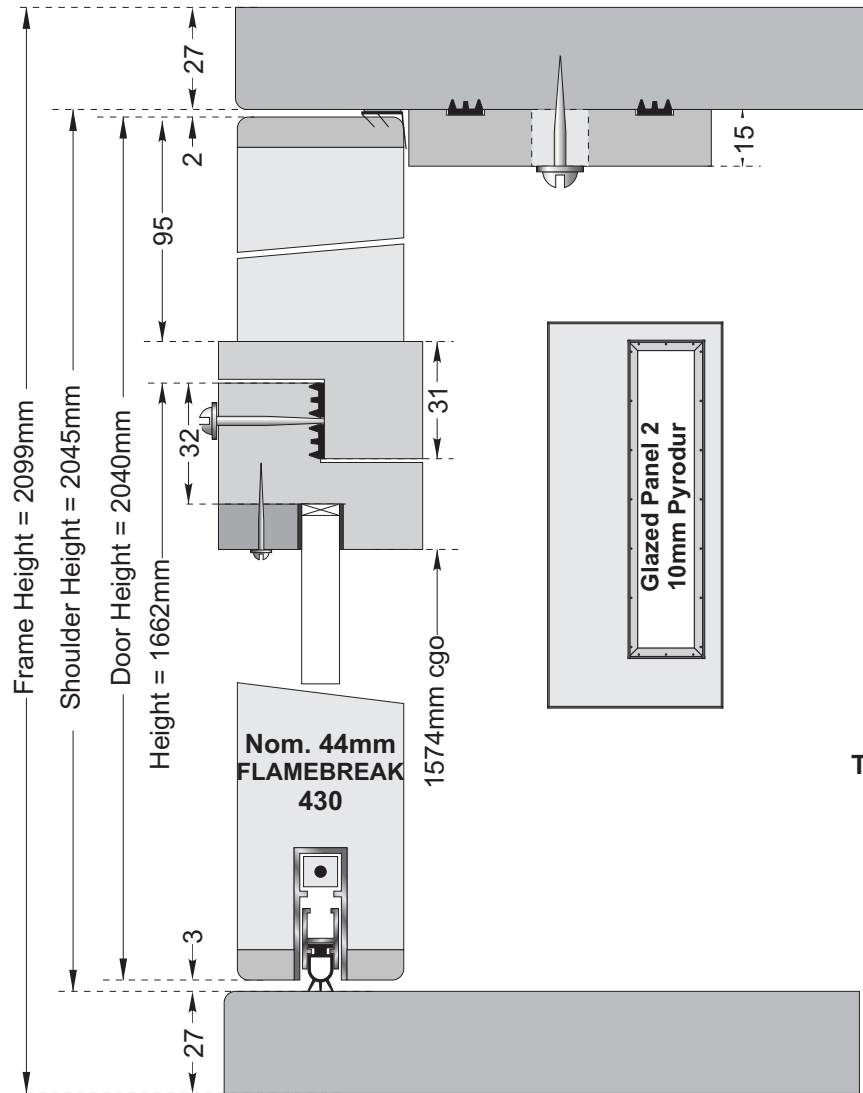

TEST 4: As Test 3 but; replace GLAZED PANEL 1 with GLAZED PANEL 2
Nom. 10mm Pyrodur glass.

Norsound Test July 2008 / 4 = SRL Test 118 = Rw.32dB

NOTE: See **GLAZING TEST DETAILS** Ref. Sk/AHP/260608/G001 ~ G010.

Dwg. Ref:	Sk/AHP/260608/T003		
TITLE	NORSOUND Acoustic Tests Test 4 AS TESTED		
Scale	1 : 2	Date	26/6/08
Revisions			

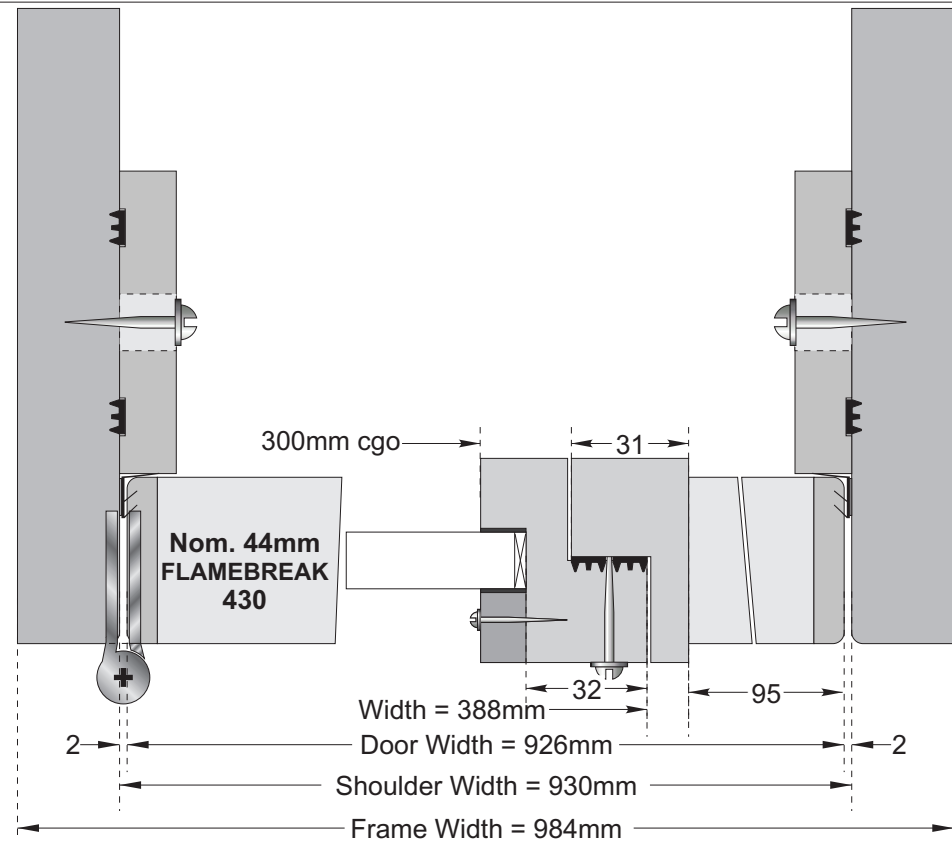
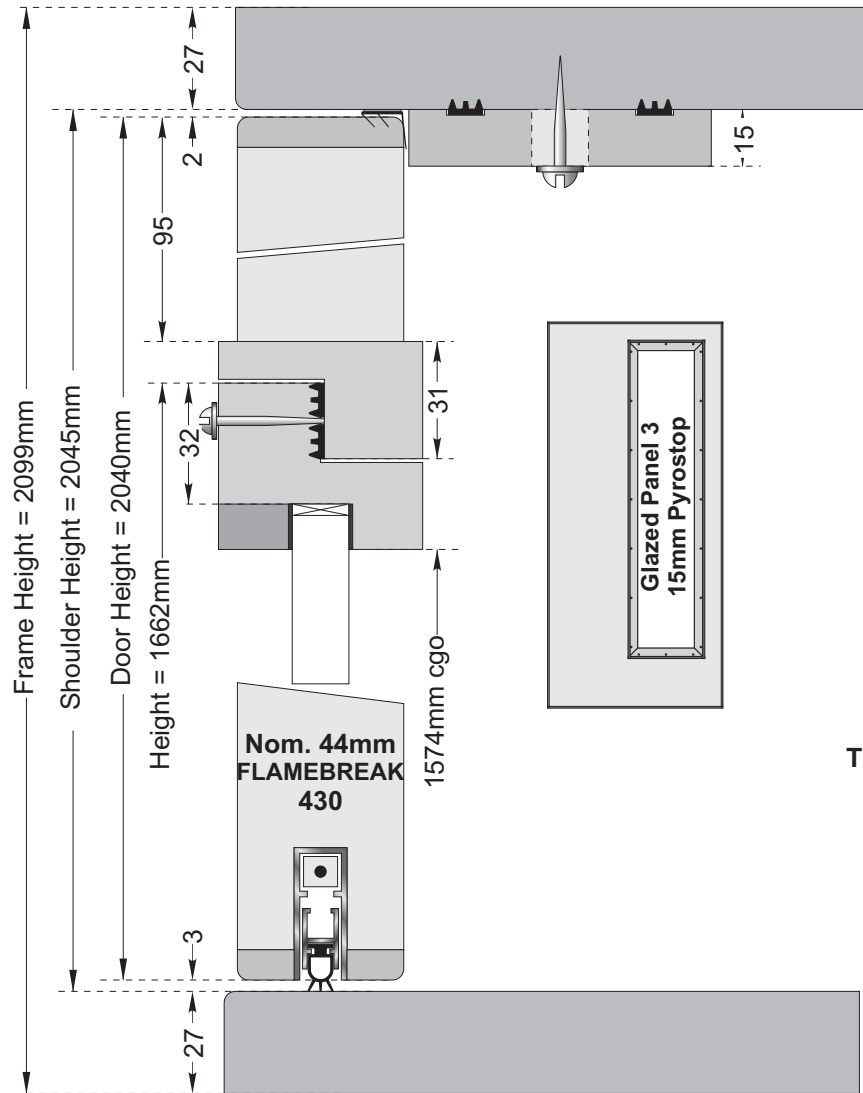

TEST 5: As Test 4 but; replace GLAZED PANEL 2 with GLAZED PANEL 3
Nom. 15mm Pyrostop glass

Norsound Test July 2008 / 5 = SRL Test 119 = Rw.32dB

NOTE: See **GLAZING TEST DETAILS Ref. Sk/AHP/260608/G001 ~ G010.**

Dwg. Ref:	Sk/AHP/260608/T004		
TITLE	NORSOUND Acoustic Tests Test 5 AS TESTED		
Scale	1 : 2	Date	26/6/08
Revisions			

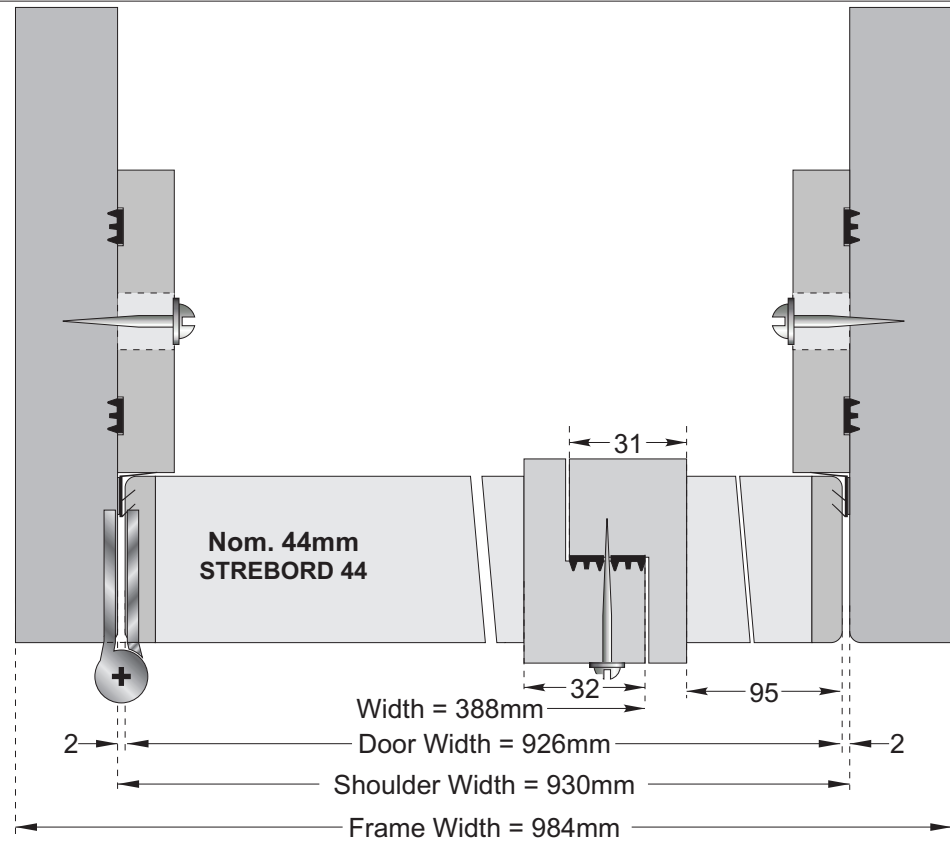
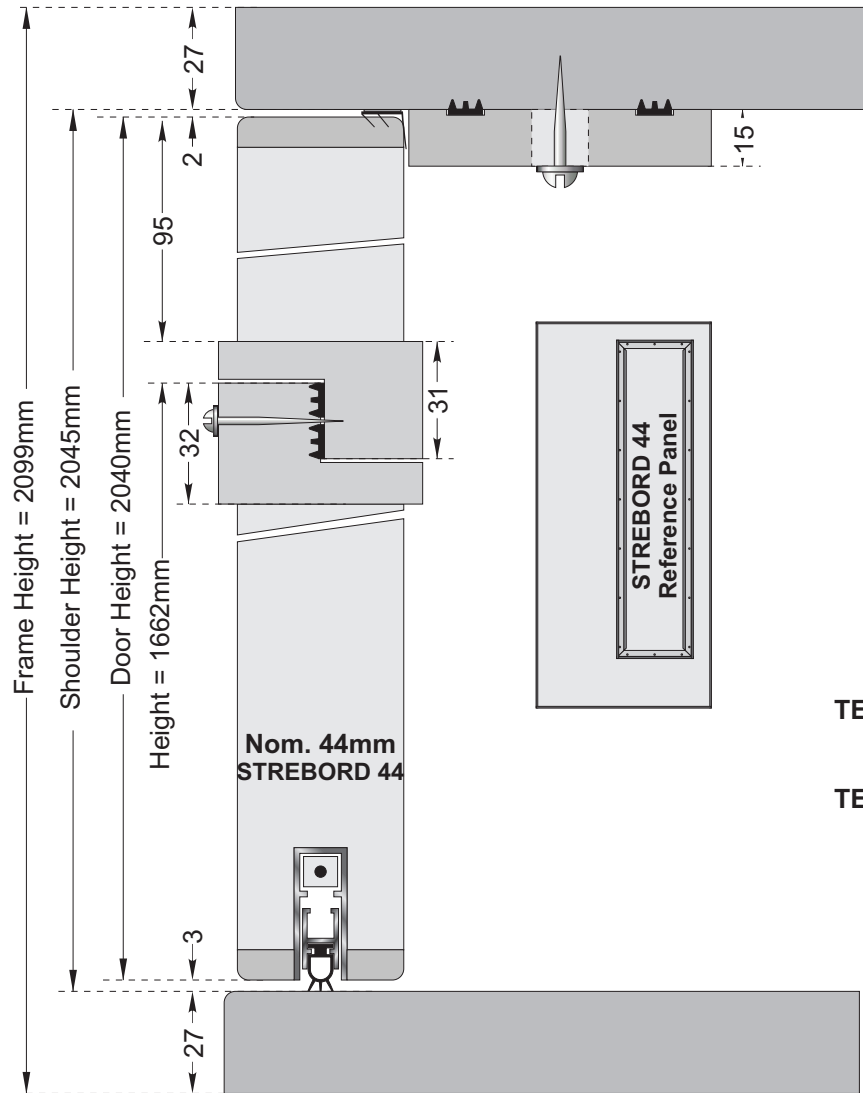

TEST 7: STREBORD 44 with STREBORD 44 solid panel fully caulked test.
Norsound Test July 2008 / 7 = SRL Test 121 = Rw.35dB

TEST 8: As Test 7 with norsound 710 to Head & Jambs & norsound 810 to Threshold.
Norsound Test July 2008 / 8 = SRL Test 124 = Rw.33dB

NOTE: See GLAZING TEST DETAILS Ref. Sk/AHP/260608/G001 ~ G009.

Dwg. Ref:	Sk/AHP/260608/T006		
TITLE	NORSOUND Acoustic Tests Tests 7 & 8 AS TESTED		
Scale	1 : 2	Date	26/6/08
Revisions			

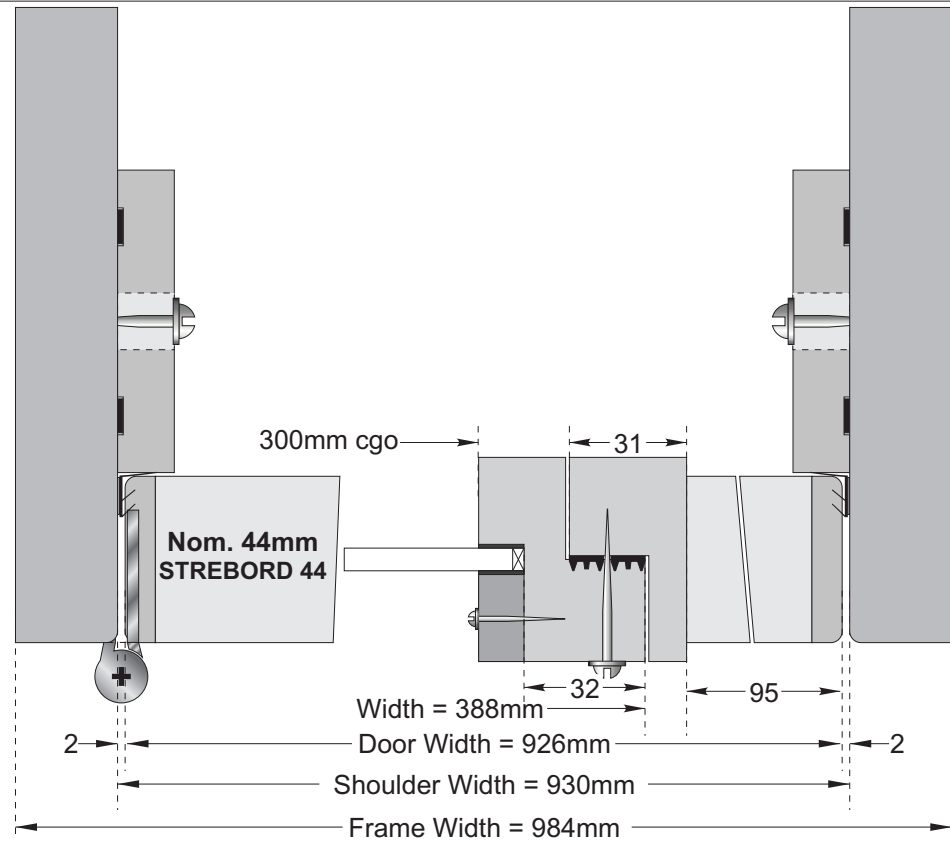
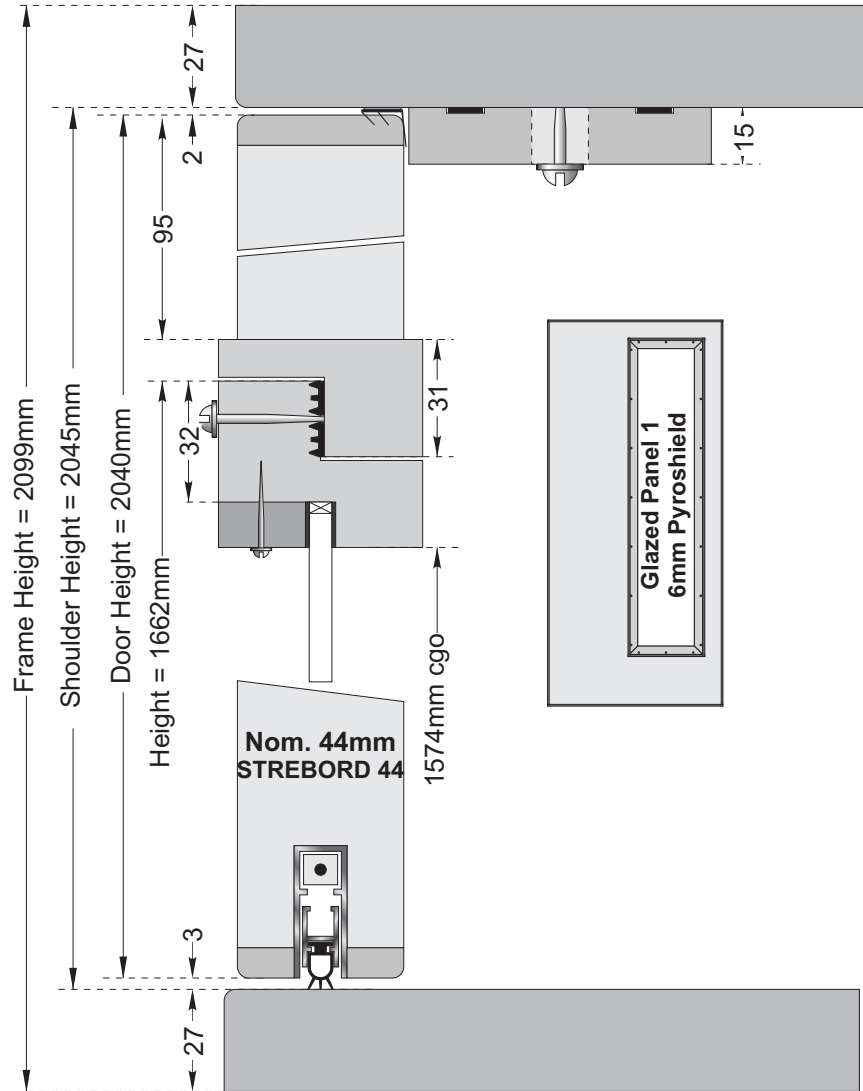

TEST 9: As Test 8 but; replace STREBORD 44 reference panel with GLAZED PANEL 1
Nom. 6mm Pyroshield glass.
Norsound Test July 2008 / 9 = SRL Test 125 = Rw.33dB

NOTE: See **GLAZING TEST DETAILS** Ref. **Sk/AHP/260608/G001 ~ G010.**

Dwg. Ref:	Sk/AHP/260608/T007		
TITLE	NORSOUND Acoustic Tests Test 9 AS TESTED		
Scale	1 : 2	Date	26/6/08
Revisions			

Tony Palmer
Doortech 2000

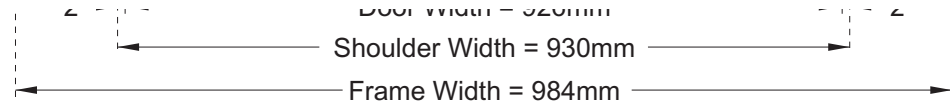
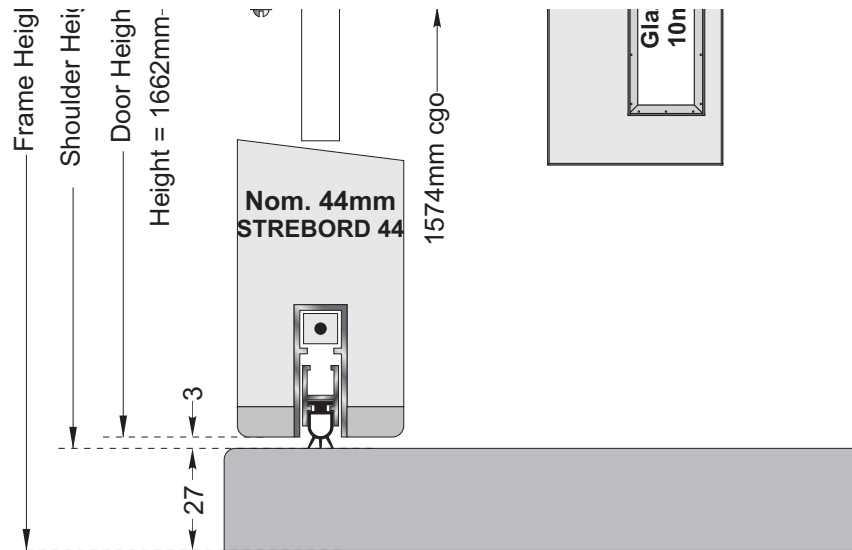
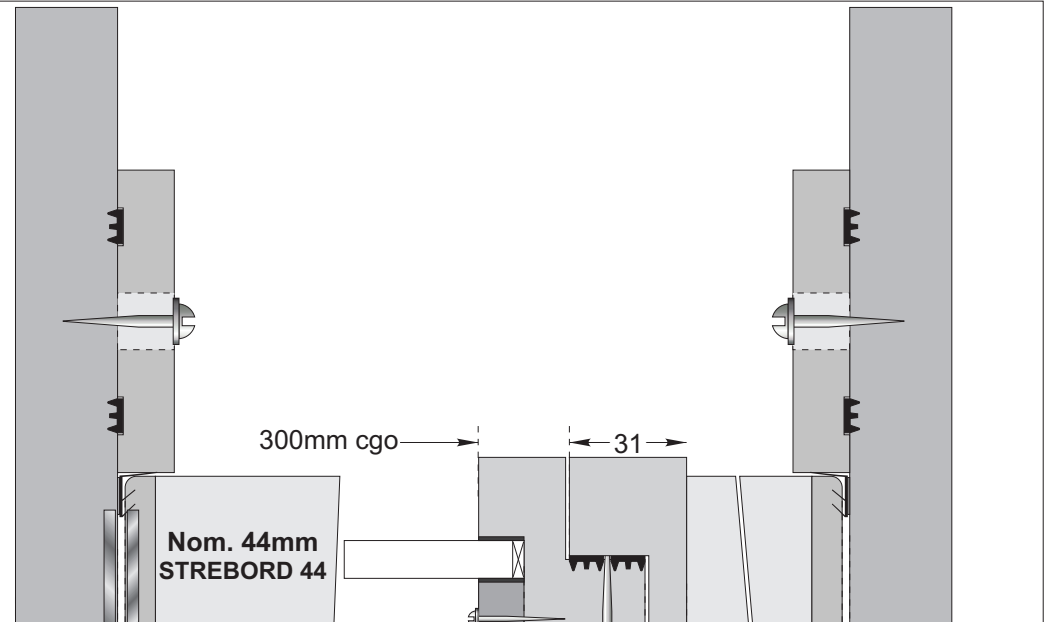
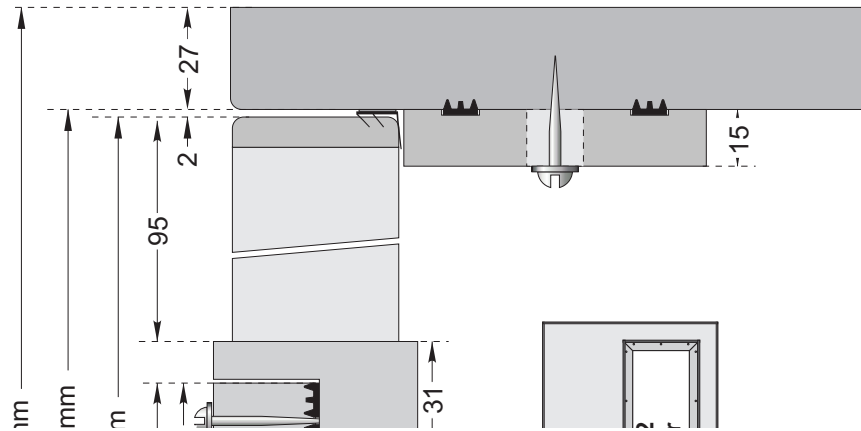

TEST 10: As test 9 but; replace GLAZED PANEL 1 with GLAZED PANEL 2
Nom. 10mm Pyrodur glass.

Norsound Test July 2008 / 10 = SRL Test 126 = Rw.33dB

NOTE: See **GLAZING TEST DETAILS** Ref. Sk/AHP/260608/G001 ~ G010.

Dwg. Ref:	Sk/AHP/260608/T008		
TITLE	NORSOUND Acoustic Tests Test 10 AS TESTED		
Scale	1 : 2	Date	26/6/08
Revisions			

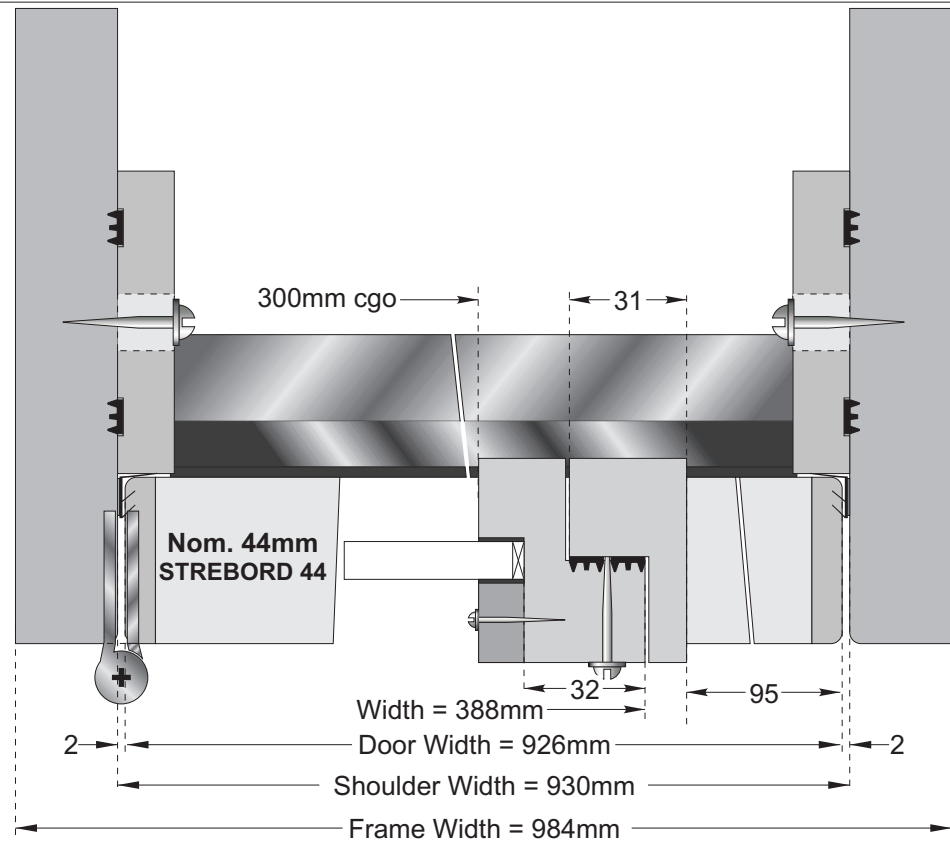
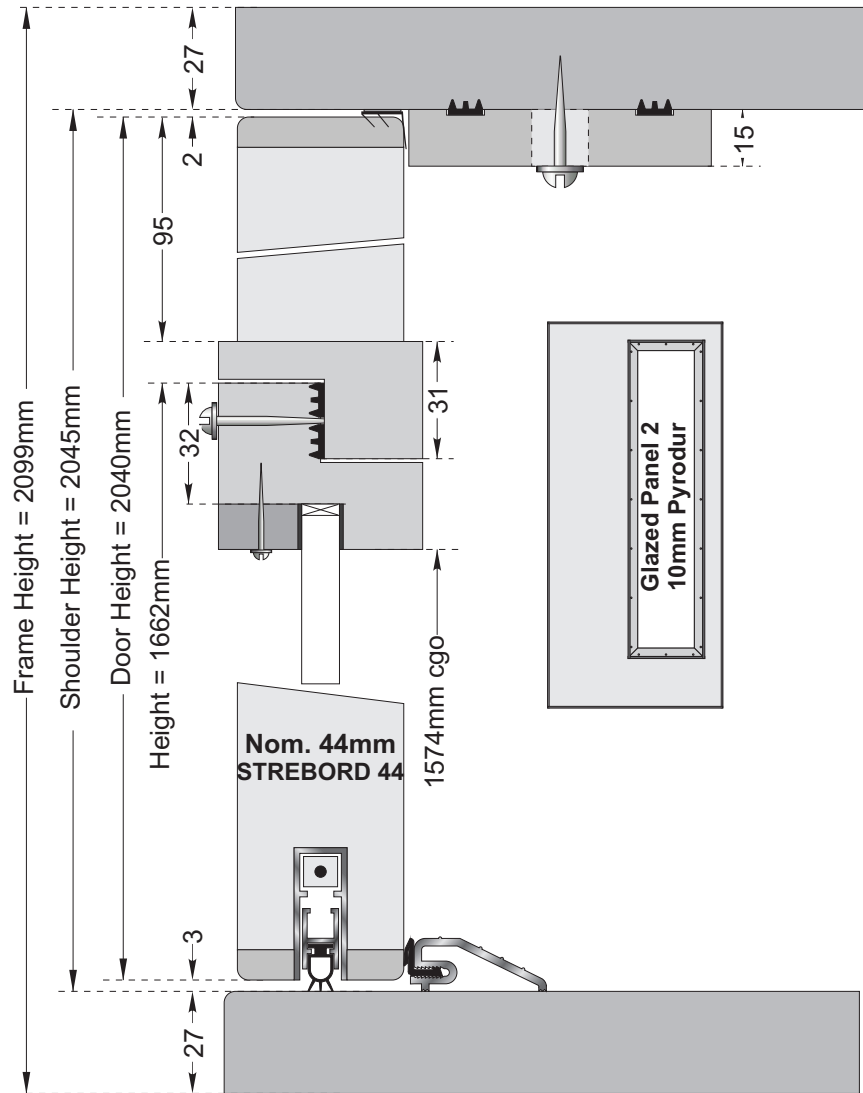

TEST 10a: All as Test 10 but modified NORSOUND 650 Threshold with seal added.

Norsound Test July 2008 / 10a = SRL Test 127 = Rw.34dB

NOTE: See GLAZING TEST DETAILS Ref. Sk/AHP/260608/G001 ~ G010.

Dwg. Ref:	Sk/AHP/260608/T008a		
TITLE	NORSOUND Acoustic Tests Test 10a AS TESTED		
Scale	1 : 2	Date	26/6/08
Revisions			

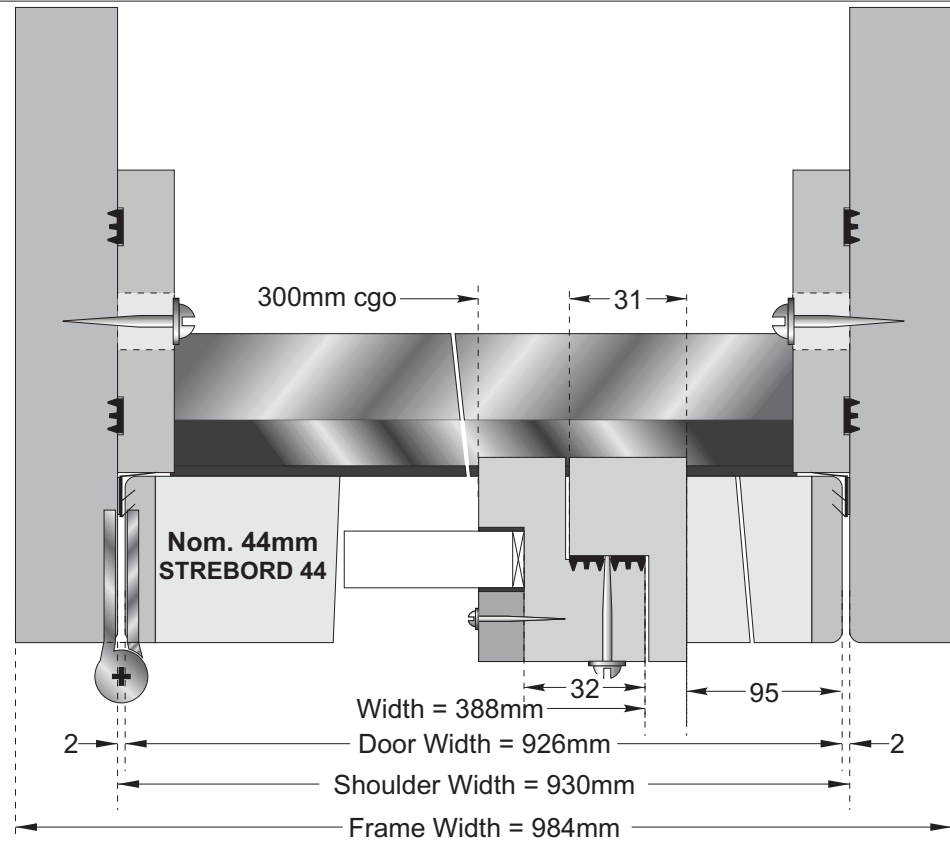
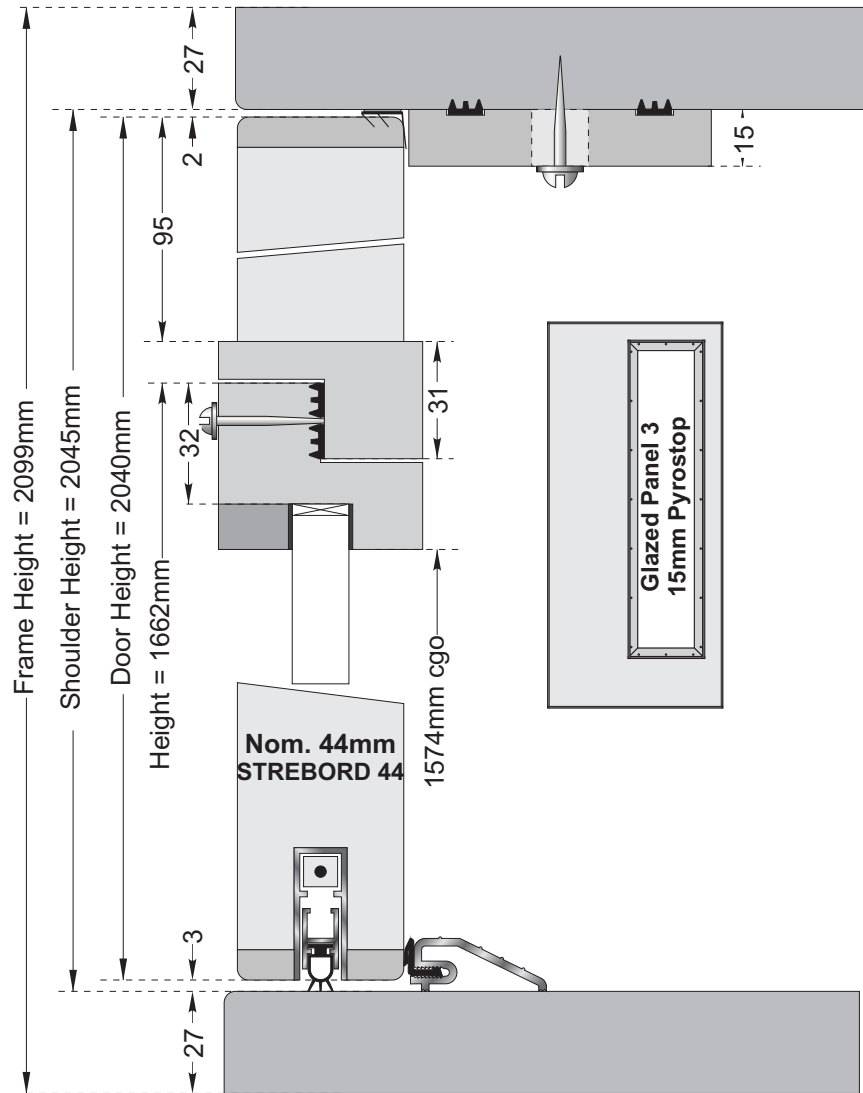

TEST 11: As Test 10a but; replace GLAZED PANEL 2 with GLAZED PANEL 3
Nom. 15mm Pyrostop glass.

Norsound Test July 2008 / 11 = SRL Test 128 = R_w .35dB

NOTE: See **GLAZING TEST DETAILS** Ref. *Sk/AHP/260608/G001 ~ G010*.

Dwg. Ref:	Sk/AHP/260608/T009		
TITLE	NORSOUND Acoustic Tests Test 11 AS TESTED		
Scale	1 : 2	Date	26/6/08
Revisions			

Tony Palmer
Doortech, 2000

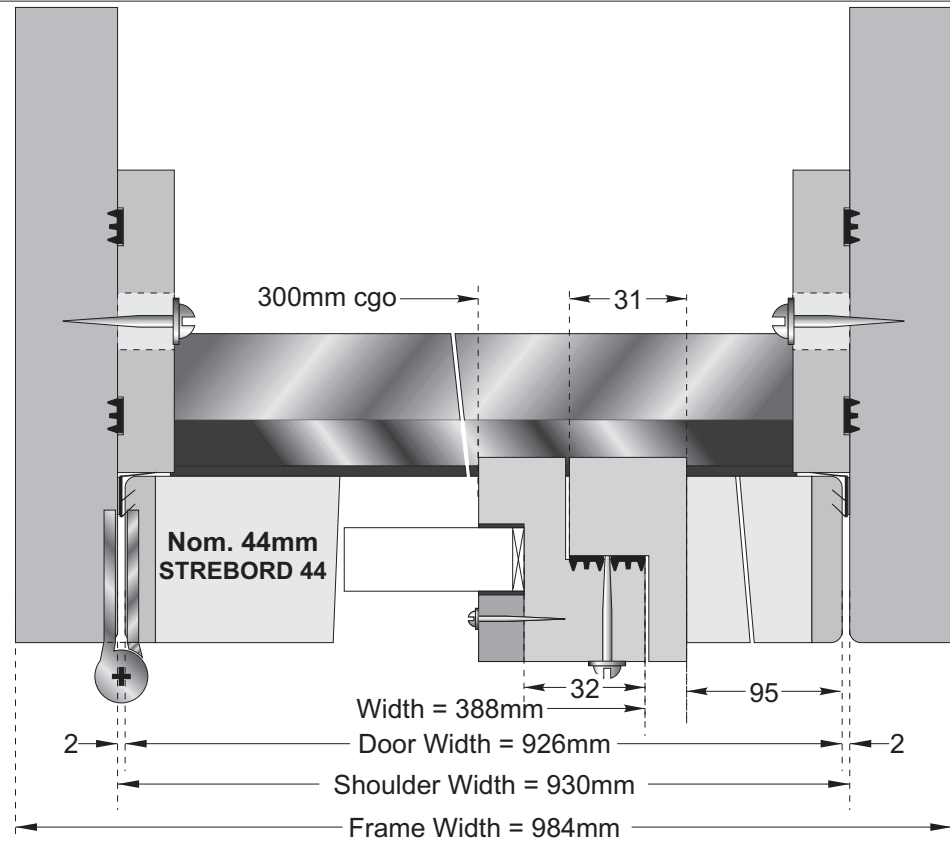
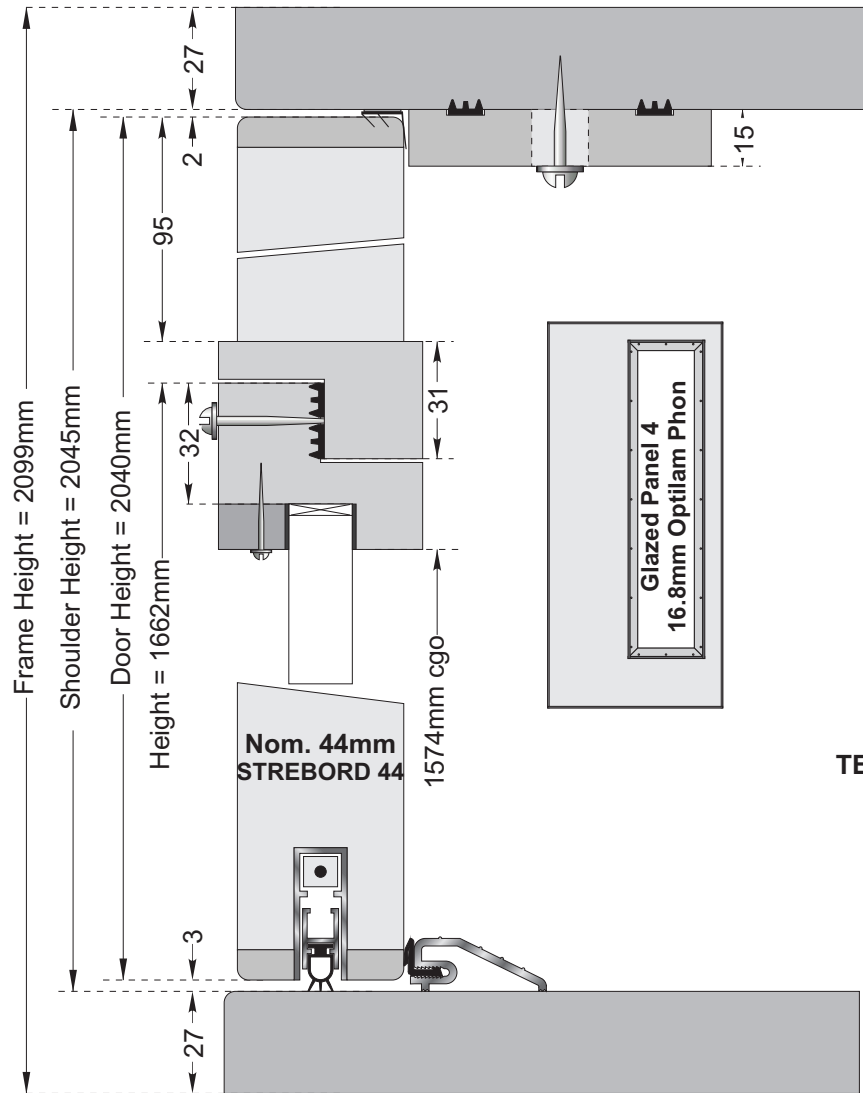

TEST 12: As Test 11 but; replace GLAZED PANEL 3 with GLAZED PANEL 4
 Nom. 16.8mm Optilam Phon glass.

Norsound Test July 2008 / 12 = SRL Test 129 = Rw.35dB

NOTE: See GLAZING TEST DETAILS Ref. Sk/AHP/260608/G001 ~ G010.

Dwg. Ref:	Sk/AHP/260608/T010		
TITLE	NORSOUND Acoustic Tests Test 12 AS TESTED		
Scale	1 : 2	Date	26/6/08
Revisions			

Tony Palmer
Doortech, 2000

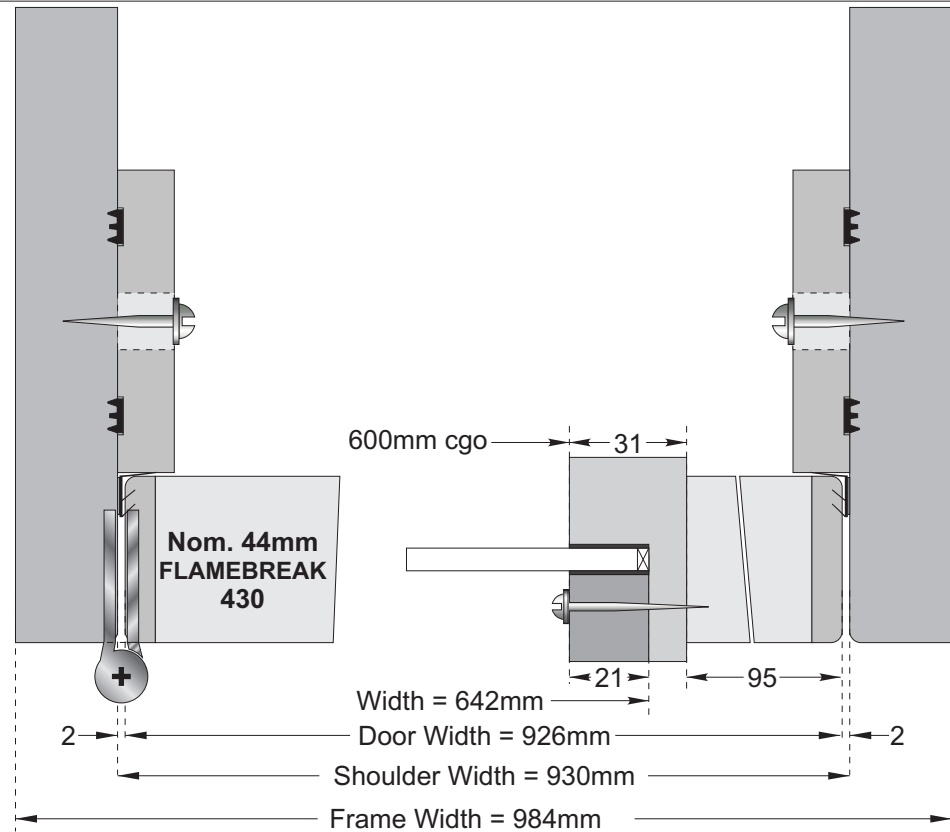
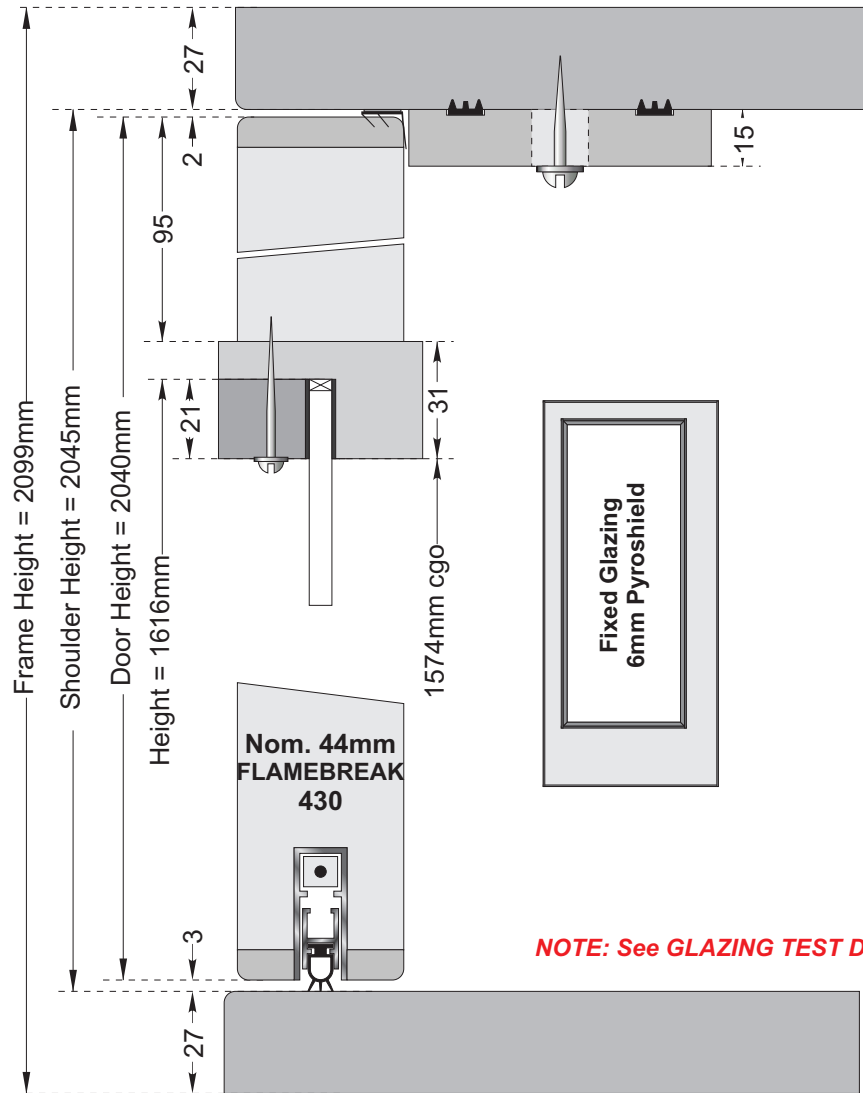

TEST 13: Replace door with FLAMEBREAK 430 glazed 6mm Pyroshield glass with a clear glass area equal to 50% of the door leaf area. Fully caulked test.

Norsound Test July 2008 / 13 = SRL Test 130 = Rw.33dB

TEST 14: Test same door with NORSOUND 710 to Head & Jambs & NORSOUND 810 to Threshold.

Norsound Test July 2008 / 14 = SRL Test 131 = Rw.32dB

NOTE: See GLAZING TEST DETAILS Ref. Sk/AHP/260608/G001 ~ G010.

Dwg. Ref:	Sk/AHP/260608/T011		
TITLE	NORSOUND Acoustic Tests Test 13 & 14 AS TESTED		
Scale	1 : 2	Date	26/6/08
Revisions			

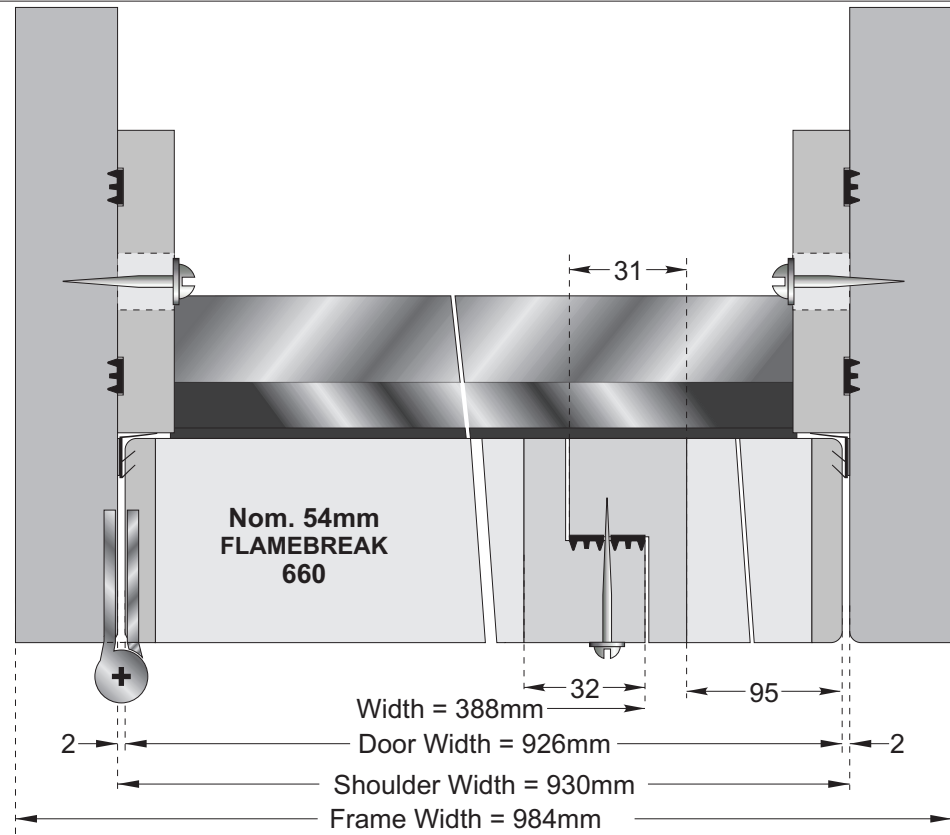
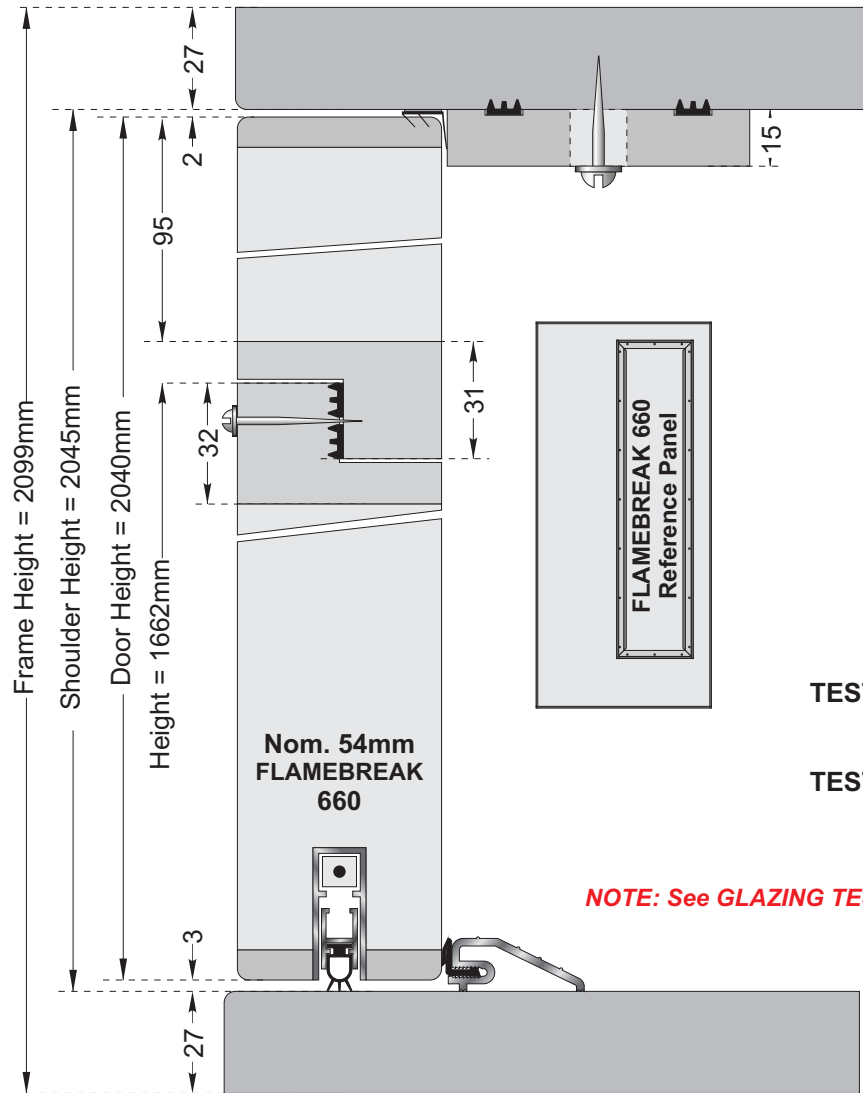

TEST 24: FLAMEBREAK 660 with FLAMEBREAK 660 solid panel fully caulked test.
Norsound Test July 2008 / 24 = SRL Test 132 = Rw.35dB

TEST 25: As Test 24 with NORSOUND 710 to Head & Jamb & NORSOUND 810 & modified NORSOUND 650 to Threshold.
Norsound Test July 2008 / 25 = SRL Test 139 = Rw.34dB

NOTE: See GLAZING TEST DETAILS Ref. Sk/AHP/260608/G001 ~ G009.

Dwg. Ref:	Sk/AHP/260608/T011a		
TITLE	NORSOUND Acoustic Tests Tests 24 & 25 AS TESTED		
Scale	1 : 2	Date	26/6/08
Revisions			

Tony Palmer
Doortech, 2000

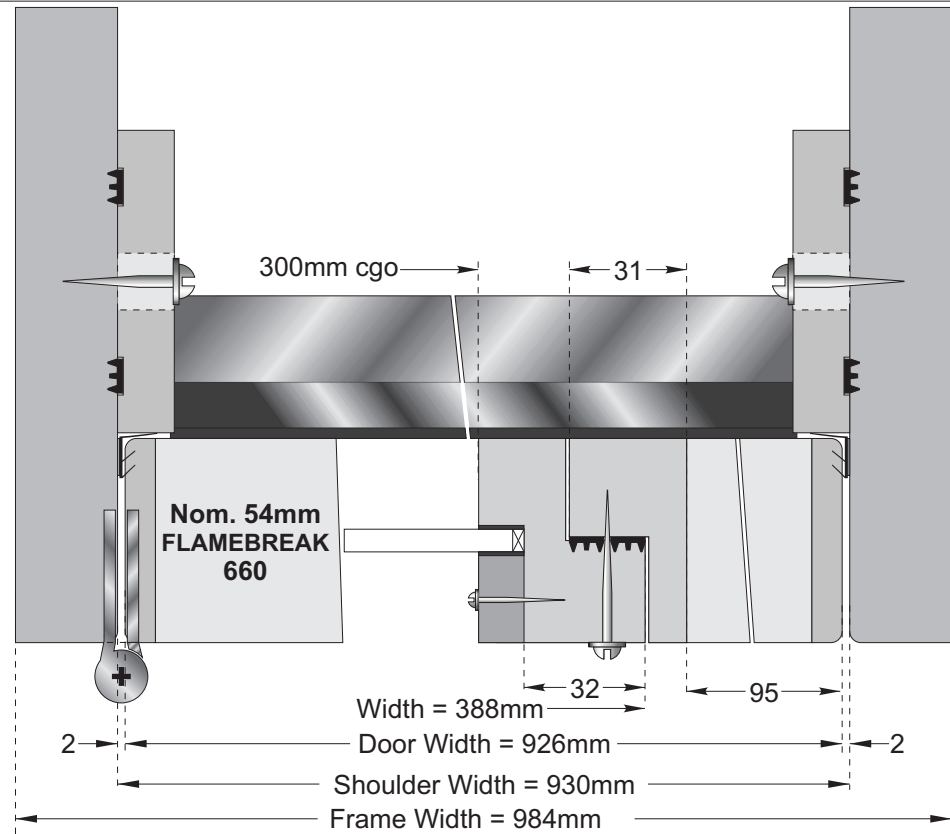
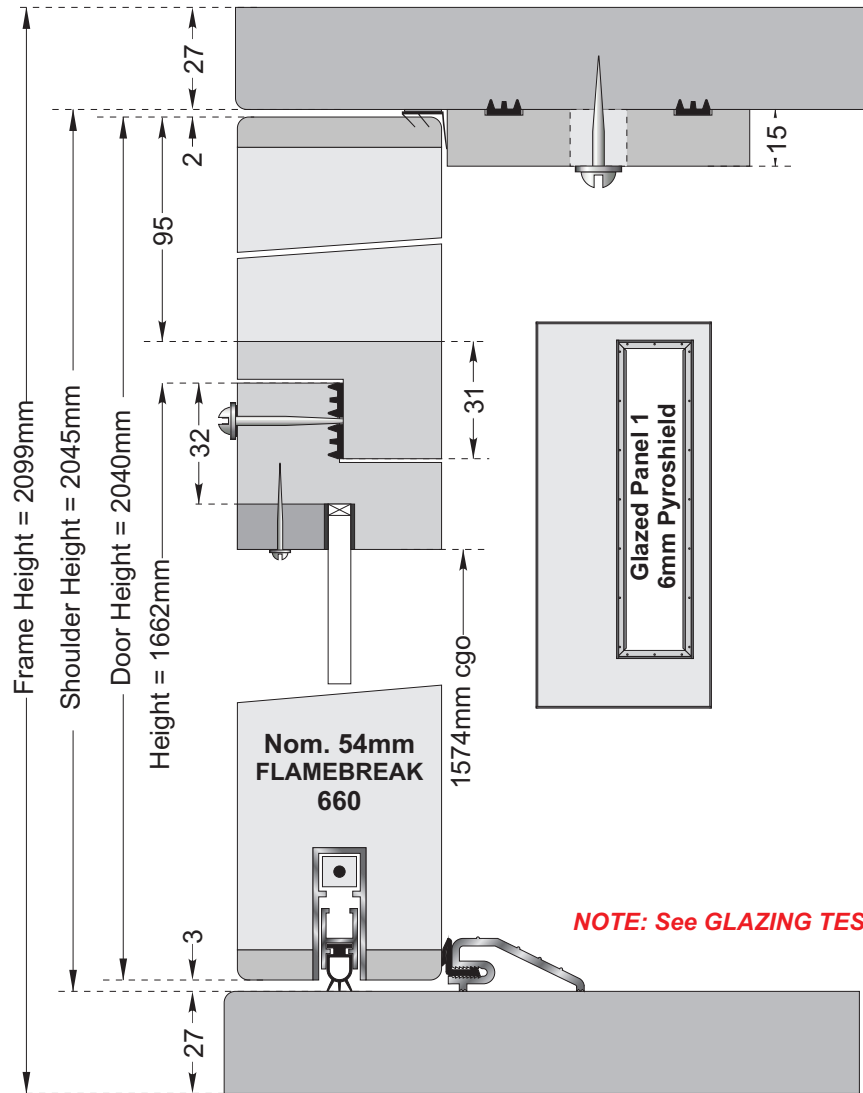

TEST 26: As Test 25 but; replace FLAMEBREAK 660 reference panel with GLAZED PANEL 1 Nom. 6mm Pyroshield glass.

Norsound Test July 2008 / 26 = SRL Test 140 = Rw.34dB

TEST 26a: FLAMEBREAK 660 with GLAZED PANEL 1 Nom. 6mm Pyroshield glass. Fully caulked.

Norsound Test July 2008 / 26a = SRL Test 133 = Rw.35dB

NOTE: See GLAZING TEST DETAILS Ref. Sk/AHP/260608/G001 ~ G010.

Dwg. Ref:	Sk/AHP/260608/T011b		
TITLE	NORSOUND Acoustic Tests Tests 26 & 26a AS TESTED		
Scale	1 : 2	Date	26/6/08
Revisions			

Tony Palmer
Doortech, 2000

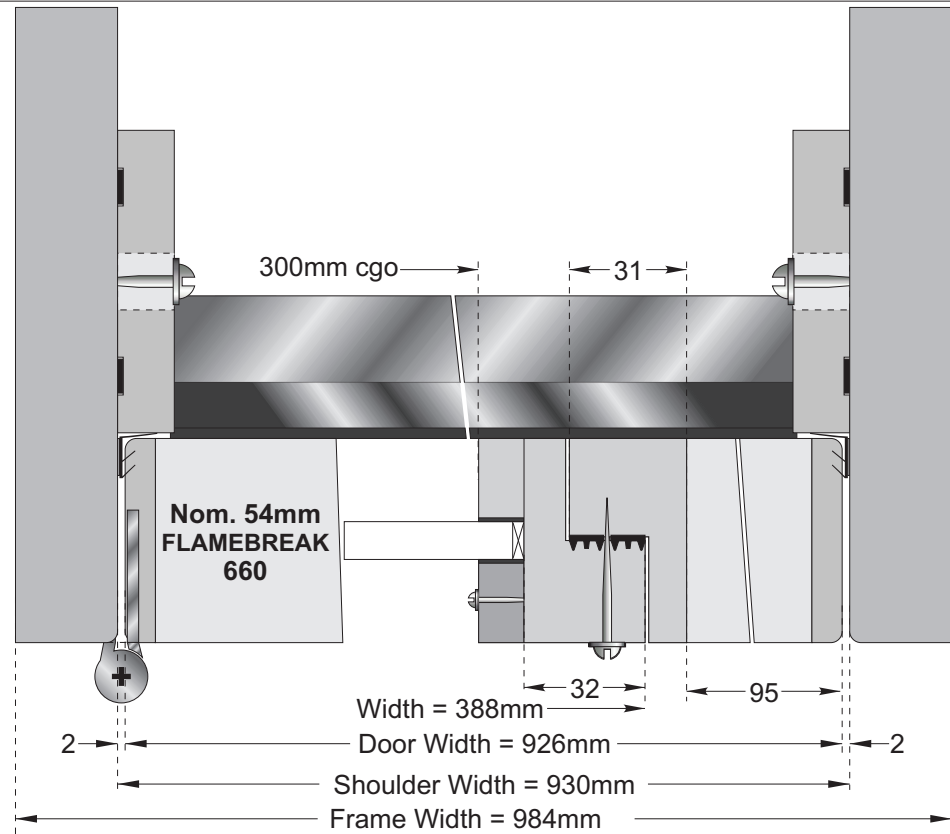
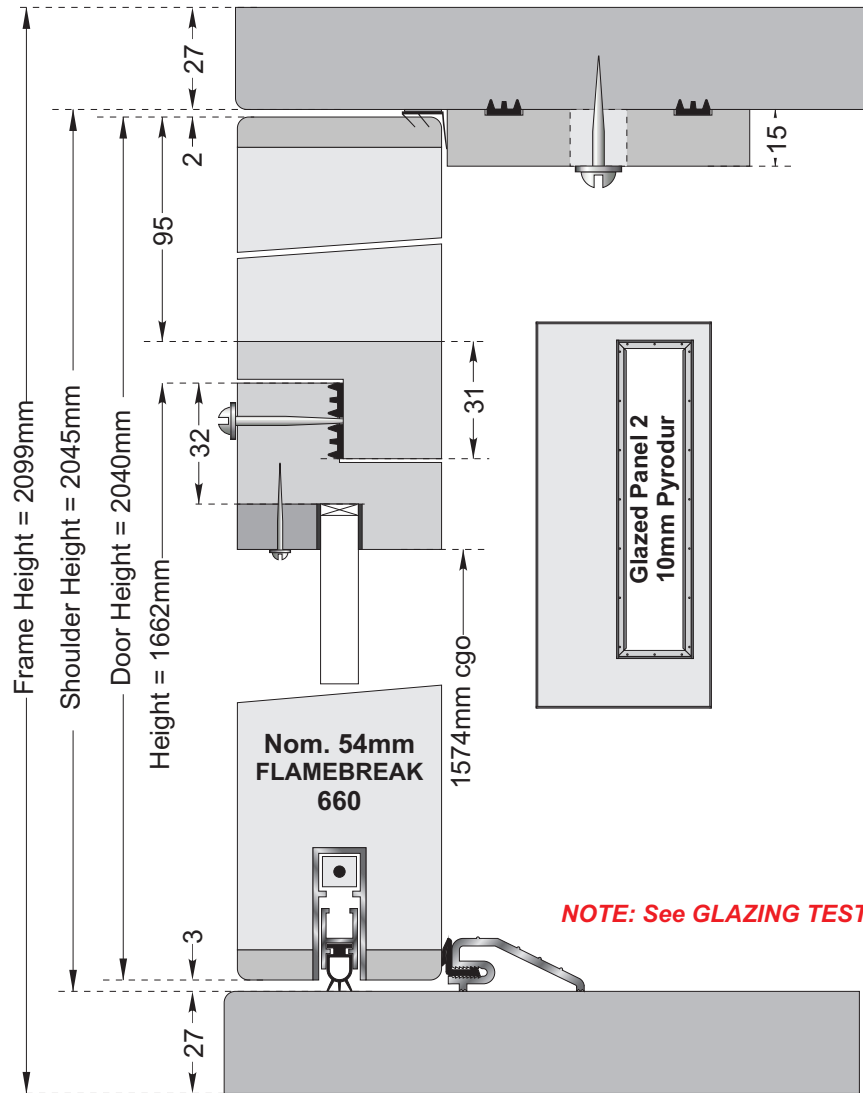

TEST 27: As Test 26 but; replace GLAZED PANEL 1 with GLAZED PANEL 2
Nom. 10mm Pyrodur glass.

Norsound Test July 2008 / 27 = SRL Test 141 = Rw.35dB

TEST 27a: FLAMEBREAK 660 with GLAZED PANEL 1 Nom. 10mm Pyrodur glass.
Fully caulked.

Norsound Test July 2008 / 27a = SRL Test 134 = Rw.36dB

NOTE: See GLAZING TEST DETAILS Ref. Sk/AHP/260608/G001 ~ G010.

Dwg. Ref:	Sk/AHP/260608/T011c		
TITLE	NORSOUND Acoustic Tests Test 27 & 27a AS TESTED		
Scale	1 : 2	Date	26/6/08
Revisions			

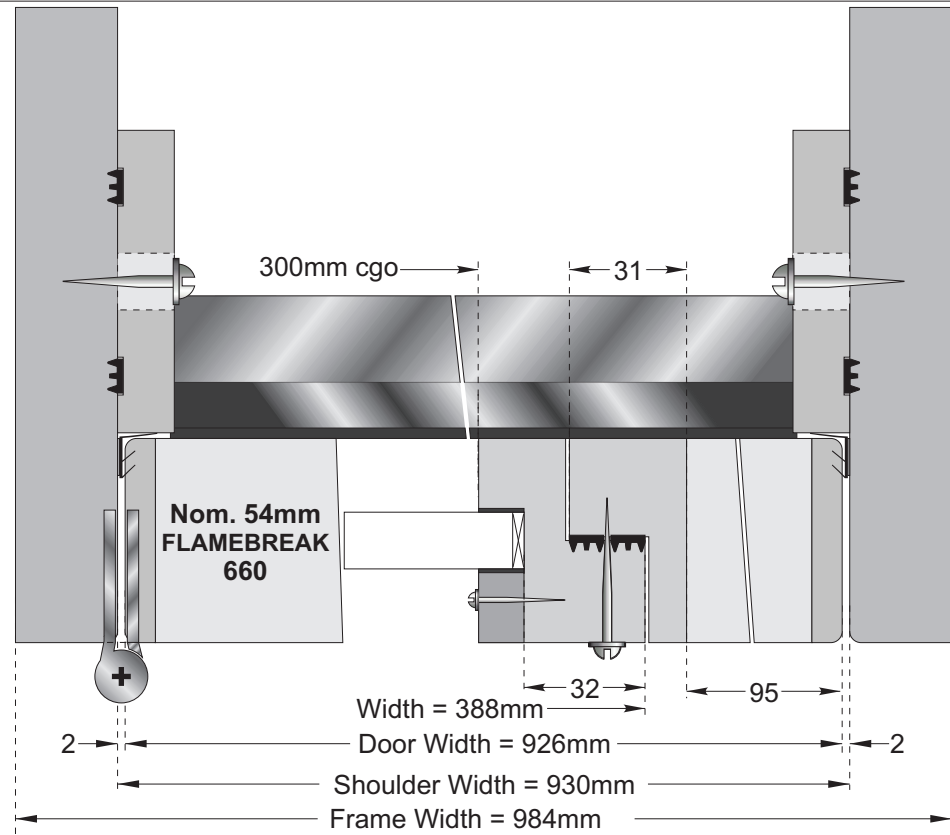
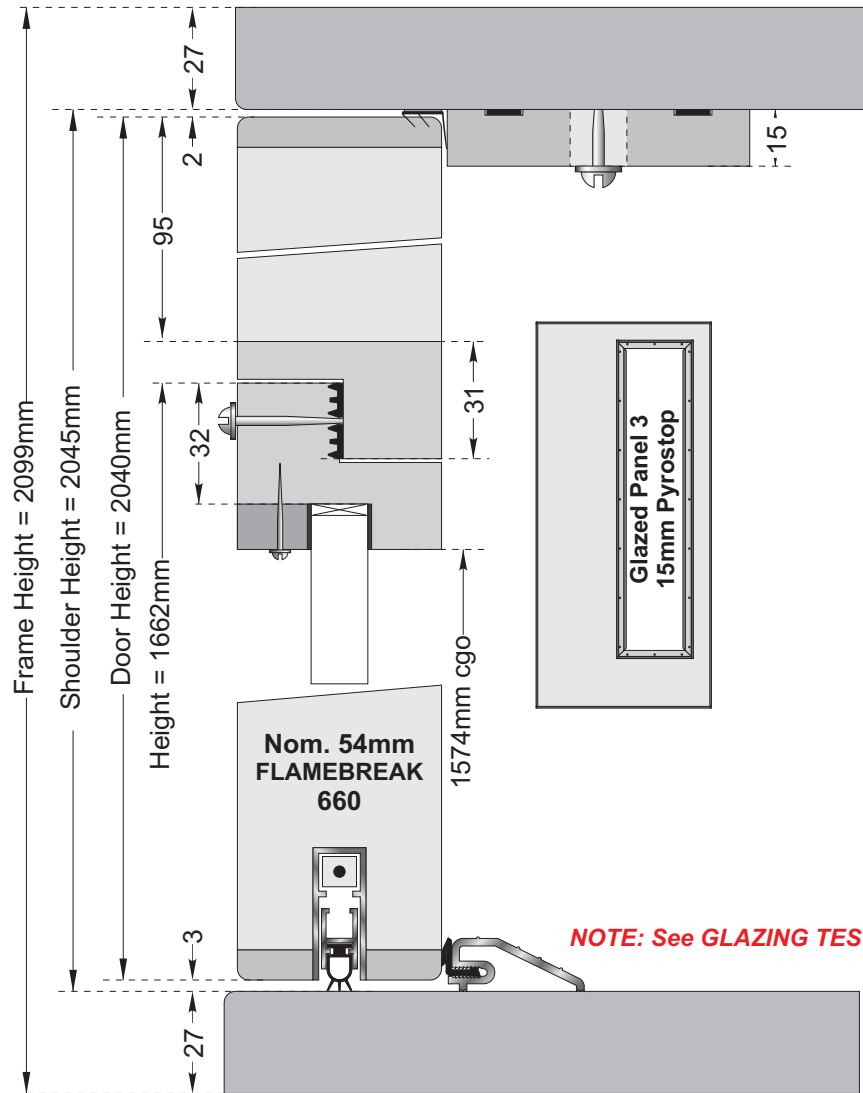

TEST 28: As Test 27 but; replace GLAZED PANEL 2 with GLAZED PANEL 3
Nom. 15mm Pyrostop glass.

Norsound Test July 2008 / 27 = SRL Test 142 = Rw.35dB

TEST 28a: FLAMEBREAK 660 with GLAZED PANEL 3 Nom. 15mm Pyrostop glass.
Fully caulked.

Norsound Test July 2008 / 27 = SRL Test 135 = Rw.36dB

NOTE: See GLAZING TEST DETAILS Ref. Sk/AHP/260608/G001 ~ G010.

Dwg. Ref:	Sk/AHP/260608/T011d		
TITLE	NORSOUND Acoustic Tests Test 28 & 28a AS TESTED		
Scale	1 : 2	Date	26/6/08
Revisions			

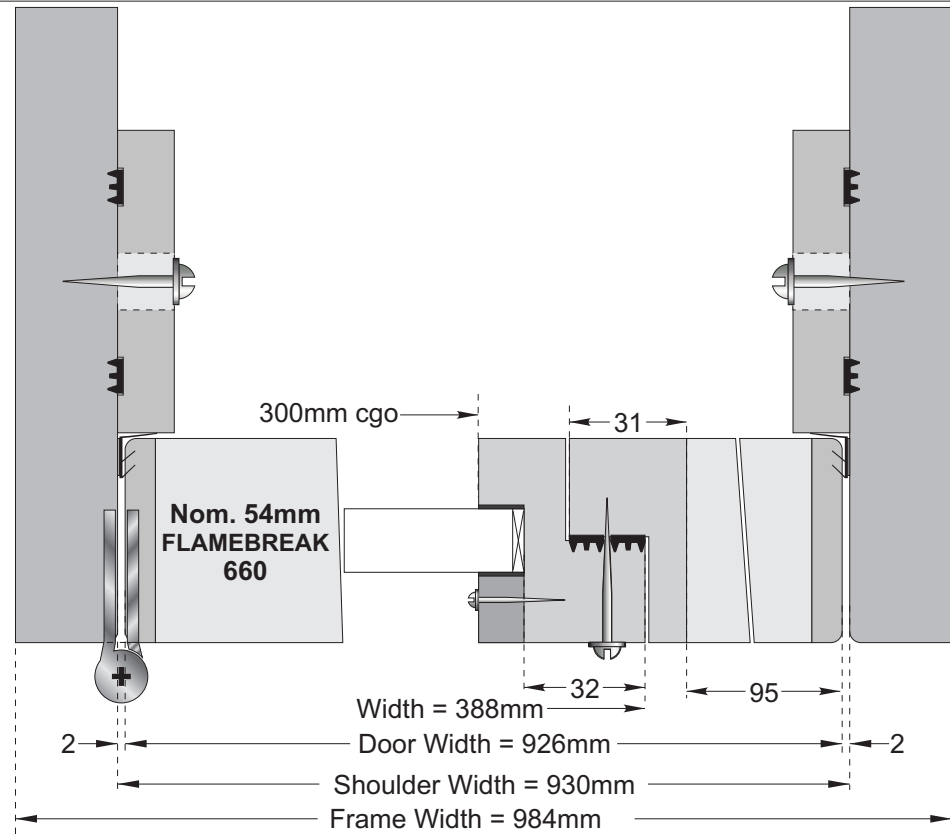
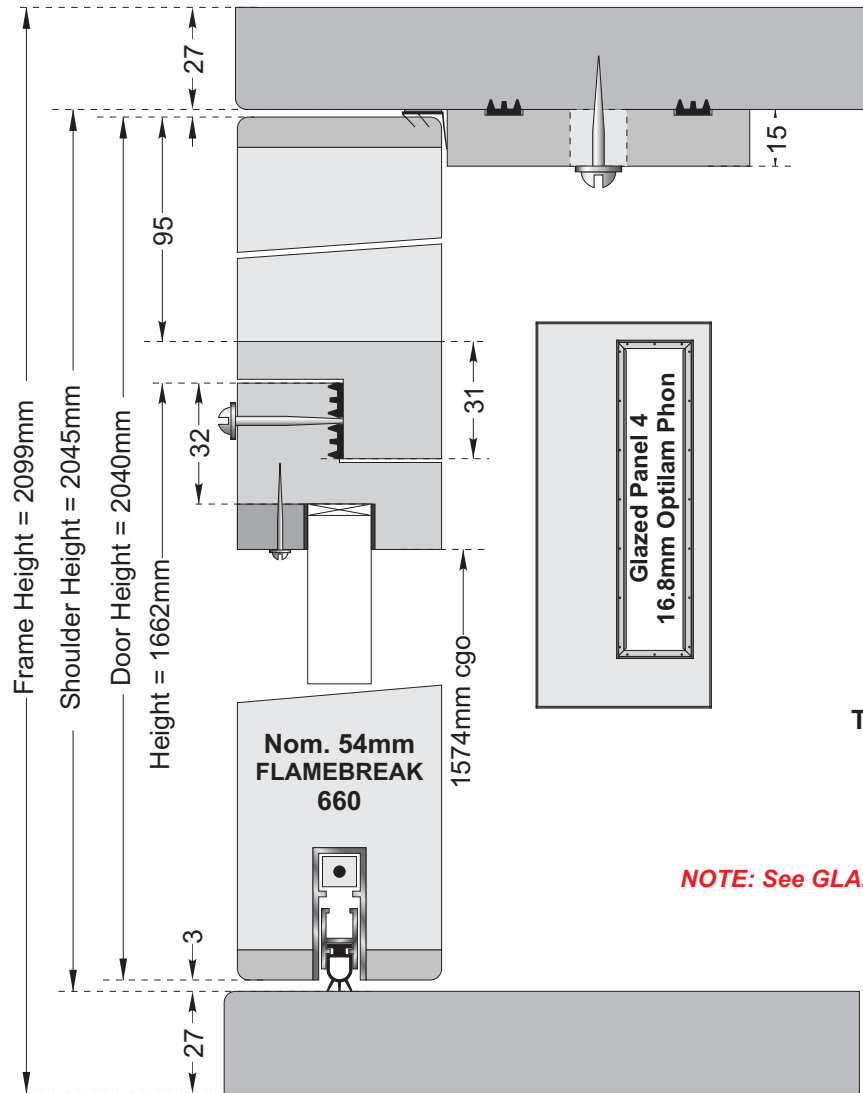

TEST 29: Replace GLAZED PANEL 3 with GLAZED PANEL 4
 Nom. 16.8mm Optilam Phon glass. NORSOUND 650 removed.
 Norsound Test July 2008 / 29 = SRL Test 137 = Rw.34dB

NOTE: See GLAZING TEST DETAILS Ref. Sk/AHP/260608/G001 ~ G010.

Dwg. Ref:	Sk/AHP/260608/T011e		
TITLE	NORSOUND Acoustic Tests Test 29 AS TESTED		
Scale	1 : 2	Date	26/6/08
Revisions			

Tony Palmer
Doortech 2000

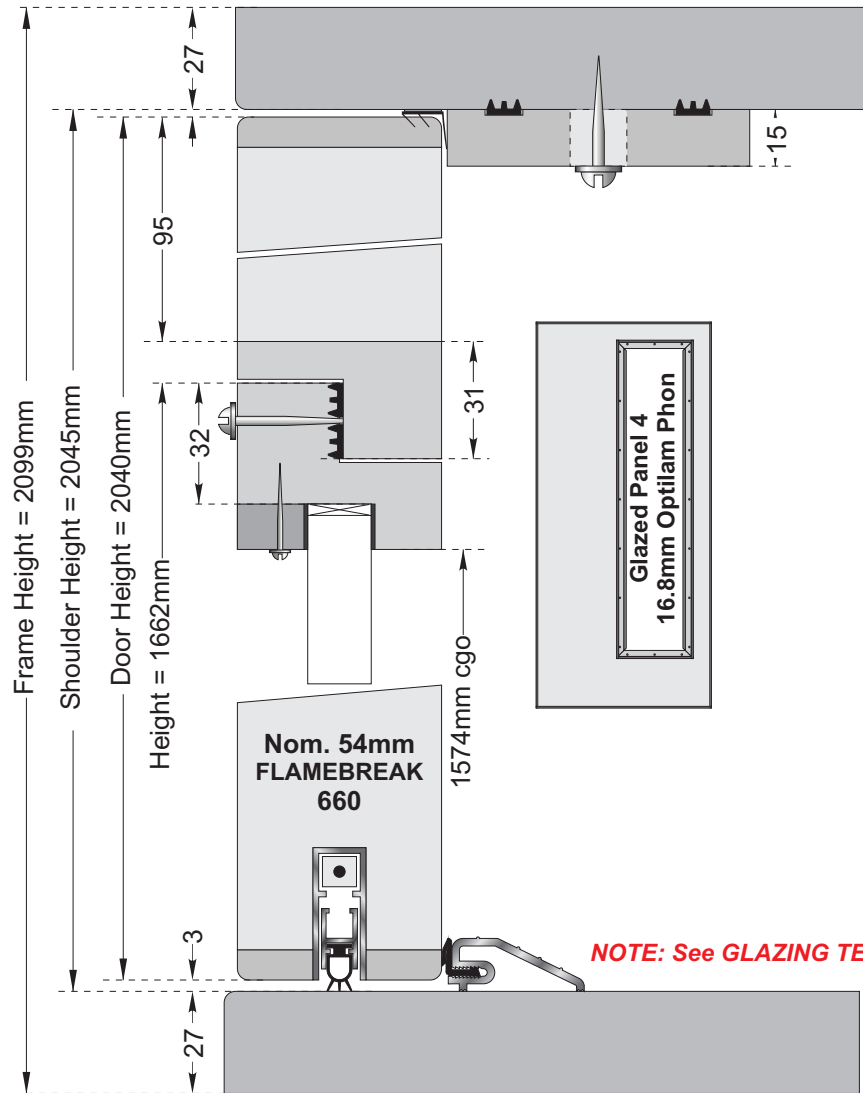

NOTE: See GLAZING TEST DETAILS Ref. Sk/AHP/260608/G001 ~ G010.

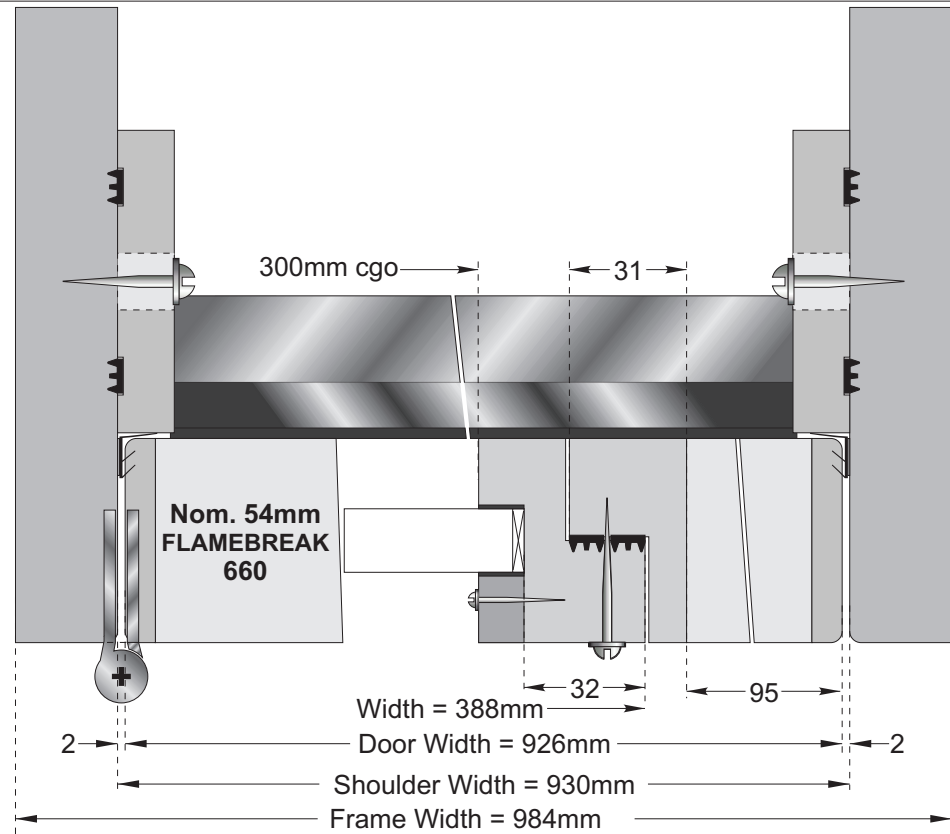

TEST 29a: FLAMEBREAK 660 with GLAZED PANEL 4 Nom. 16.8mm Optilam Phon glass. Fully caulked.

Norsound Test July 2008 / 29a = SRL Test 136 = Rw.36dB

TEST 29b: All as Norseal Test 29 but with modified NORSOUND 650 Threshold strip with seal added.

Norsound Test July 2008 / 29b = SRL Test 138 = Rw.35dB

Dwg. Ref:	Sk/AHP/260608/T011f		
TITLE	NORSOUND Acoustic Tests Test 29a & 29b AS TESTED		
Scale	1 : 2	Date	26/6/08
Revisions			

Tony Palmer
Doortech 2000

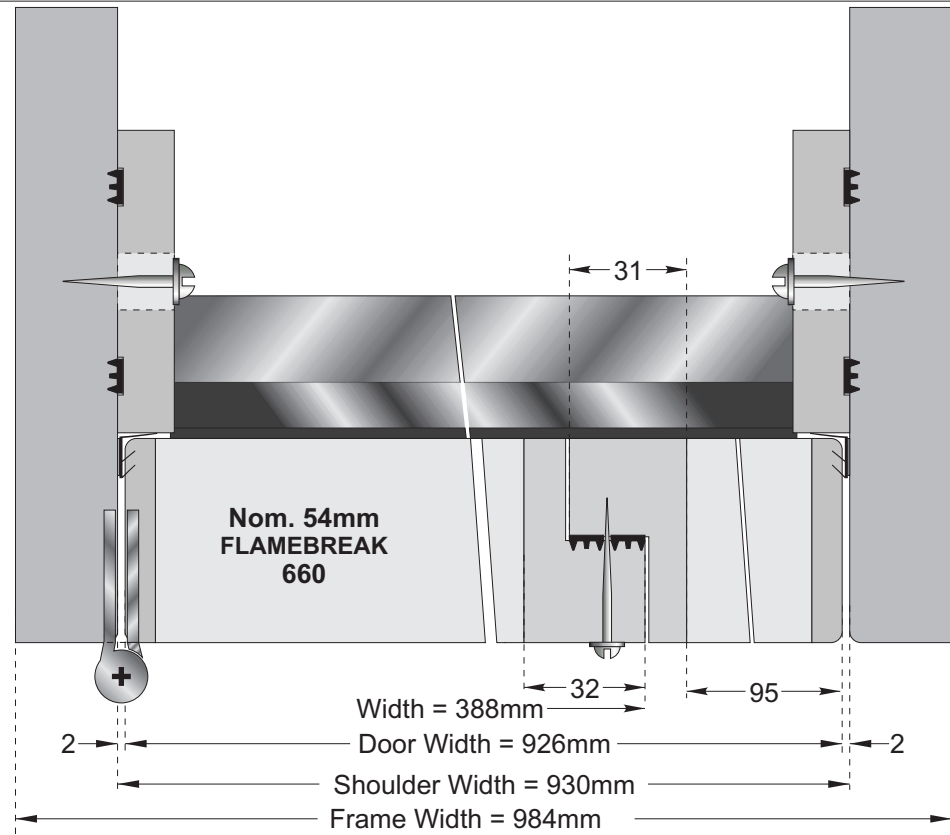
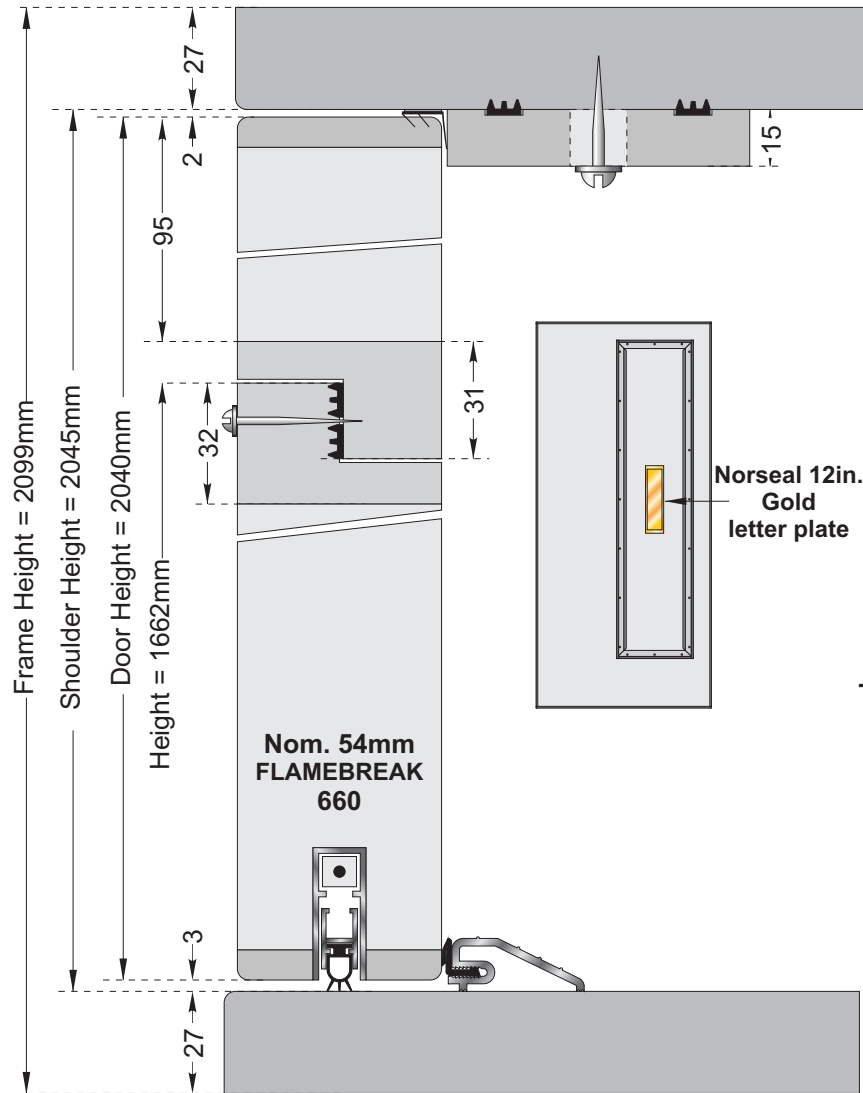

TEST 30: FLAMEBREAK 660 with FLAMEBREAK 660 solid panel all as Test 25 but with Norseal 12in. Gold letter plate fitted to door.
Norsound Test July 2008 / 30 = SRL Test 143 = Rw.33dB

Dwg. Ref:	Sk/AHP/260608/T012		
TITLE	NORSOUND Acoustic Tests Test 30 AS TESTED		
Scale	1 : 2	Date	26/6/08
Revisions			

Tony Palmer
Doortech, 2000

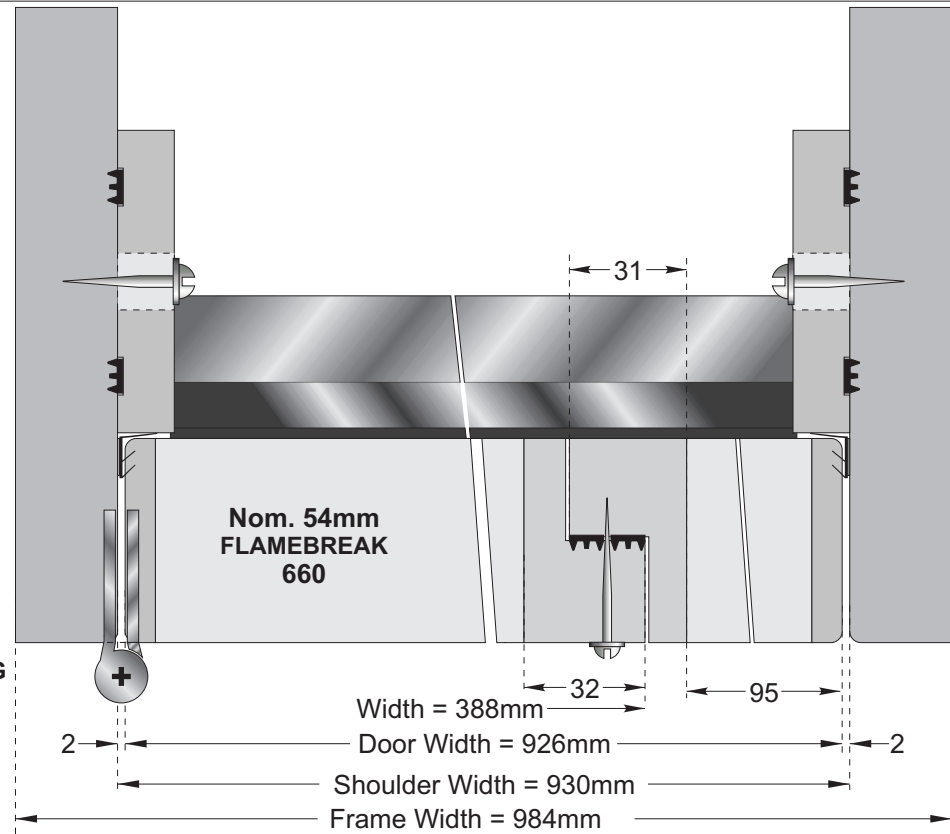
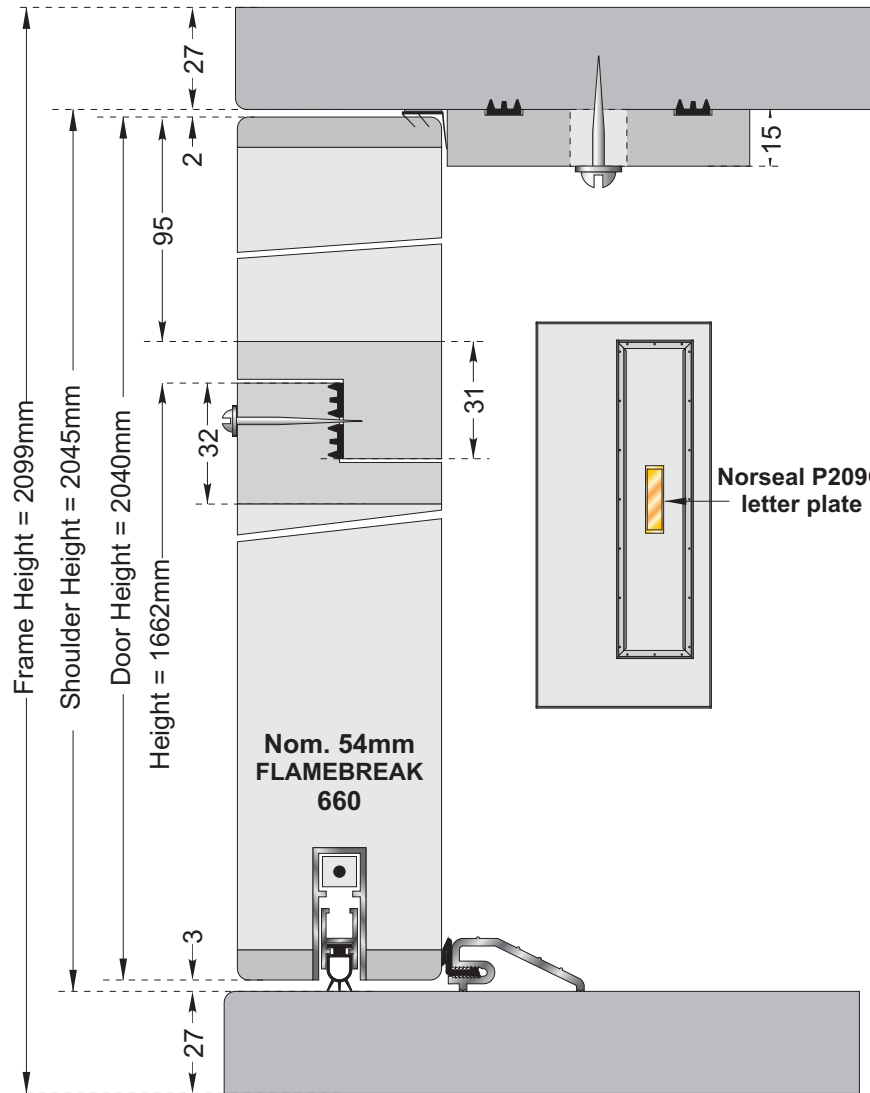

TEST 31: FLAMEBREAK 660 with FLAMEBREAK 660 solid panel all as Test 25 but with Norseal P209G letter plate fitted to door.
Norsound Test July 2008 / 31 = SRL Test 144 = Rw.32dB.

TEST 31a: All as Test 31 but letter plate reversed in door and 'E' seal strip added to letter plate flap to one side.
Norsound Test July 2008 / 31a = SRL Test 145 = Rw.33dB

Dwg. Ref:	Sk/AHP/260608/T013		
TITLE	NORSOUND Acoustic Tests Test 31 & 31a AS TESTED		
Scale	1 : 2	Date	26/6/08
Revisions			

