

# Hambleside Danelaw

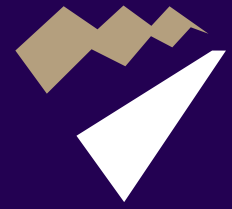

GRP Flashings, Roof and Cavity  
Ventilation Products



[www.hambleside-danelaw.co.uk](http://www.hambleside-danelaw.co.uk)

Edition **15**



**VENTILATION**

**Roof Space**

- 2 Technical Notes on Ventilation
- 3 Product Applications – Ventilation
- 5 Soffit Ventilators  
Circular Soffit Ventilator  
Corbel Ventilator
- 6 Over Fascia Ventilators  
Airflow Diagrams
- 7 Universal Panel Ventilators  
Single and Double  
Flyscreen Ventilators
- 8 3 in 1 Ventilator Pack  
Roll Panel and Universal  
Refurbishment Tray  
Ventilators
- 9 Slate Roof Ventilators  
Universal and Flush  
Fitting Slate Roof  
Ventilators  
Soil Pipe Adapter Kits
- 10 Tile Roof Ventilators  
Plain Tile Roof Ventilator  
Soil Pipe Adapter Kits
- 11 Dry Fix Ventilated Ridge System

**VENTILATION**

**Cavity and Underfloor**

- 12 Telescopic Underfloor Ventilator  
Combination Brick Ventilator  
Airbrick Ventilator  
Sleeves  
Ventilator Grilles
- 13 Square to Round Adapter  
Universal Weep Ventilator  
Lintel Stop End  
Perp Weep and Extension

**GRP FLASHINGS**

**Roof and Wall**

- 14 Dry Fix Valley Trough for Slate Roofs  
Dry Fix Valley Trough for Tile Roofs
- 15 StormForce 225®  
Tile Valley Troughs  
Slate Valley Troughs  
Scottish Slate Valley Trough
- 16 Installation of GRP Valley Troughs
- 17 Dry Fix Bonding Gutter and Bonding Gutter®
- 18 Damp Proof Course  
Continuous Eaves Course  
Universal Abutment Cover  
Flashing
- 19 Continuous Soakers for Slates and Tiles
- 20 Dry Soakers for Slates and Tiles
- 21 Dry Verges  
Scotverge

**GENERAL**

**Ancillary Products**

- 22 Underlay Support Tray  
Rigid Underlay Support Tray  
Moisture Diversion Plate  
Loft Access Doors

This brochure is designed to provide an overall guide to the Hambleside Danelaw Roofing and Ventilation range of products. Further technical information is available by contacting our Daventry Sales Office on 01327 701910.

**HAMBLESIDE DANELAW AND THE ENVIRONMENT**

Brief details on our environmental policy are shown on the back cover of this brochure. Copies of our Environment brochure and our Corporate Social Responsibility statement are available on our web site or through our Daventry office.

**Accreditation**



Hambleside Danelaw GRP flashing products carry BBA Certification. The range of valley troughs hold unique BBA multi-product certification.



Hambleside Danelaw is BS EN ISO 14001:2004 Environmental Management Systems - Registered.



Where appropriate products have been independently tested for suitability, purpose and performance by Birmingham City Laboratories.



The Hambleside Danelaw Group are CPD and RIBA CPD Certified providers.



**Memberships**

Hambleside Danelaw is a member of the RIBA NBS Plus electronic library service.



Hambleside Danelaw is an associate member of the Builders Merchant Federation.



Hambleside Danelaw are associate manufacturing members of the National Federation of Roofing Contractors and also participate in the co-partnership guarantee scheme.

The illustrations below reflect the basic ventilation requirements which would normally be applicable. For additional information please refer to the current Building Regulations and appropriate British Standards. Dimensions in millimetres.

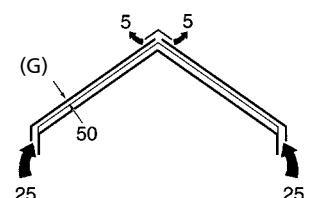
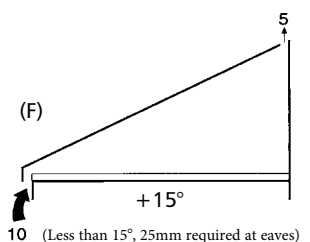
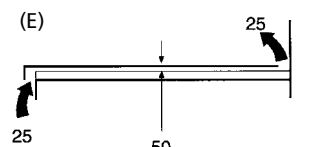
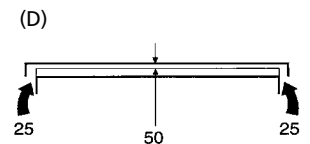
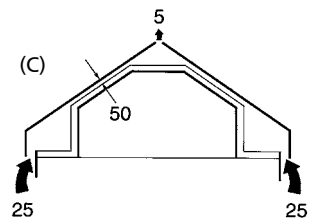
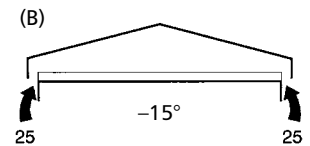
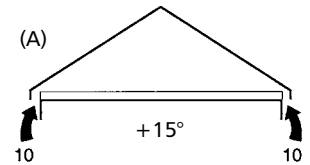



## ROOF VENTILATION

Ventilation to negate the effects of condensation in roofs is essential to comply with Building Regulations, Building Standards and British Standards. Ventilation openings should be provided on the longer sides of rectangular roofs and designed to prevent the ingress of rain, snow, birds and large insects. Minimum mesh/grille sizes should not be smaller than 4mm to avoid excessive airflow resistance. Particular attention should be paid to potential restrictions at changes in roof slope or changes in construction details and at junctions with walls. The Hambleside Danelaw range of ventilation products is manufactured to enable compliance with all current technical requirements and standards.

### BUILDING REGULATIONS – THE REQUIREMENTS

Approved Document C2 (2004 Edition including 2010 and 2013 amendments) requires that roofs be designed and constructed so that their structural and thermal performance are not adversely affected by interstitial condensation.

This requirement will be met if the roof is designed and constructed in accordance with Annex H of BS 5250:2011 'Code of practice for control of condensation in buildings' and BS ENISO13788:2012 'Hygrothermal performance of building components and building elements. Internal surface temperature to avoid critical surface humidity and interstitial condensation. Calculation methods.' Further guidance is given in BRE Report BR262 'Thermal insulation: avoiding risks', 2002 edition.

To avoid excessive moisture transfer into roof voids, gaps and penetrations for pipes and electrical wiring should be filled and sealed, particularly in areas of high humidity such as kitchens and bathrooms and an effective draught seal should be provided to loft hatches to reduce the inflow of warm air and moisture. Vapour control layers can reduce the amount of vapour entering roof voids but cannot be relied on as an alternative to ventilation. A complete barrier to moisture is needed for this.

Scottish Technical Handbooks section 3.15 requires that dwellings shall be so constructed as to protect the building and its users, so far as may be reasonably practicable, from harmful effects caused by surface and interstitial condensation. Both these requirements are deemed to be satisfied by following the guidance given in BS 5250.

BS 5534:2003 + AI : 2010 'Code of practice for slating and tiling (including shingles)' recommends that roof ventilation be provided in accordance with BS 5250.

### COLD ROOFS WITH A PITCH OF 15° OR MORE

Pitched roof spaces should have ventilation openings at eaves level (Fig. A) on opposite sides of the structure at least equal to an opening of 10mm wide and running the full length of the eaves to promote cross ventilation. For roof pitches above 35° or spans in excess of 10m, additional high level ventilation at or close to the ridge equivalent to a continuous opening of 5mm should be provided.

A pitched roof that has a single slope or abuts a wall (Fig. F) should have ventilation at high level equal to a continuous opening of 5mm wide in conjunction with an opening of at least 10mm wide at the eaves.

High level ventilation should never be used on its own as the wind suction effect created will increase water vapour transfer into the roof void.

Pitched roofs where part or all the insulation follows the pitch of the roof (Fig. C) should have ventilation openings on opposite sides of the structure at least equal to a continuous opening of 25mm wide. In addition, such structures require ventilation at or close to the ridge equivalent to a continuous opening of at least 5mm. The void between the underside of the roof covering and the insulation should have a free air space of at least 50mm. In this application, a vapour control layer should also be provided on the warm side of the insulation.

### COLD ROOFS WITH A PITCH OF LESS THAN 15°

Roof spaces in low pitched and flat roofs should have ventilation openings at eaves level (Figs. B, D & E) on opposite sides of the structure at least equal to an opening of 25mm wide to promote cross ventilation. Roof voids should have a free air space of at least 50mm between the roof deck or underside of the roof covering and the insulation.

Mono pitched roofs should be provided with ventilation of at least the equivalent of a 25mm continuous opening at eaves and 5mm at the ridge.

### WARM ROOFS

Condensation should be controlled by ventilation beneath the underlay and above the insulation by the provision of a 25mm wide continuous ventilation opening or equivalent at eaves or low level and a 5mm continuous ventilation opening or equivalent at the ridge or high level. The space between the underlay and the insulation should be at least 50mm deep with a minimum of 25mm at the centre of the underlay drape. A well sealed ceiling and separate vapour control layer should be used on the warm side of the insulation.

### VAPOUR PERMEABLE UNDERLAYS

BS 5250:2011 provides recommendations and alternative approaches when using vapour permeable or 'Low Resistance' (type LR) underlays that when followed, can achieve compliance with Building Regulations. Caution should be taken when proposing to use VPU's and reduce ventilation levels on re-roof & refurbishment projects.

### Horizontal Insulation:

With slated or tiled roofs containing horizontal insulation over a horizontal ceiling, the use of an LR underlay with unsealed laps can allow for a reduction in the area of roof ventilation openings providing that the roof covering can be determined as sufficiently air open in accordance with Annex L of BS 5534:2003 but with equipment designed to measure low pressure differences down to 2 Pascals. On buildings 'typical' of housing, with insulation at ceiling level and with the LR underlay laid above or below counterbattens or onto open jointed sarking boards, the requirement is for low level continuous equivalent ventilation openings that may be reduced from 10mm to 7mm for a 'normal' ceiling and 3mm for a well sealed ceiling as defined in BS 9250:2007. For larger roofs of this type, such as supermarkets, schools, hospitals etc., the minimum equivalent opening remains at 10mm for a normal ceiling but may be reduced to 5mm for a well sealed ceiling with an additional continuous 5mm opening at high level.

Where continuous boarding or close jointed sarking boards are used under the slates or tiles, an LR underlay should be treated as a 'High Resistance' (type HR) and ventilation should always be provided to the roof space below the underlay. When an existing roof is being recovered, it may be impossible to achieve a ceiling that is as well sealed as in new build therefore caution must be taken and consideration given to providing the equivalent to at least a continuous 7mm opening or the addition of the equivalent to a continuous 5mm opening at high level.

Most proprietary low level ventilation products that provide an area equivalent to a 10mm continuous opening will easily satisfy all of the reduced ventilation requirements. BS 5250:2011 does not cover situations where it is proposed to provide no ventilation in cold roof applications. In such cases, all of the conditions and requirements of independent technical approval certification (e.g. BBA) should be met.

### Inclined Insulation:

Slated or tiled roofs that are air open containing inclined insulation above inclined ceilings may be constructed without ventilation if an LR underlay is used that can either be laid fully supported on the insulation or draped and unsupported. It is essential to provide a well sealed ceiling in accordance with BS 9250:2007 and a separate vapour control layer.

If there is any doubt about the ability to provide and maintain an effectively sealed vapour control layer then ventilation should be provided as if the underlay was impermeable or an HR type in accordance with the section headed 'Warm Roofs'.

With this type of construction, an effective vapour control layer of high vapour resistance, sealed at the laps and at all roof details, e.g. hips, valleys, ridges, abutments, firewalls and around all penetrations created by services, etc., should be provided. The designer should be sure that the vapour control layers and/or insulation can be installed and maintained air tight for the design life of the building.

### FIRE PERFORMANCE OF ROOF VENTILATION PRODUCTS

In general, and for the purposes of Building Regulations requirement B4, small plastic components such as slate and tile ventilators and soil pipe penetrations that occur on the surface of the roof and jointing and ventilation strips that appear at ridges, hips and soffits are regarded as insignificant and are therefore not covered in Approved Document B and can normally be ignored.

## UNDERFLOOR VENTILATION

### SUSPENDED FLOORS AT GROUND LEVEL

Any suspended floor next to the ground will meet the requirements of Building Regulations Approved Document C, Scottish Technical Handbook 3.4 and BS 5250:2011 Annex F provided that:

- the ground is covered so as to resist moisture and prevent plant growth and;
- there is a ventilated air space between the ground covering and the floor construction of at least 150mm and;
- there are damp-proof courses between the floor construction and any material that can carry moisture from the ground.

Two opposing external walls should have ventilation openings placed so that the ventilating air will have a free path between opposite sides and to all parts. The openings should be large enough to give an actual opening of at least equivalent to 1500mm<sup>2</sup> for each metre run of wall or 500mm<sup>2</sup> per m<sup>2</sup> of floor area whichever gives the greater opening area, a ventilation area also being provided in internal sleeper walls or similar obstructions to maintain the underfloor ventilation. Any pipes needed to carry this ventilating air should have a diameter of at least 100mm.



**PRODUCT SELECTION**

As a general guide to assist in choosing the correct products from the Hambleside Danelaw range, first identify the type of roof detail from the typical examples **A** to **G** illustrated, then select the combination of products from the range to achieve full cross flow ventilation in accordance with the Building Regulations.

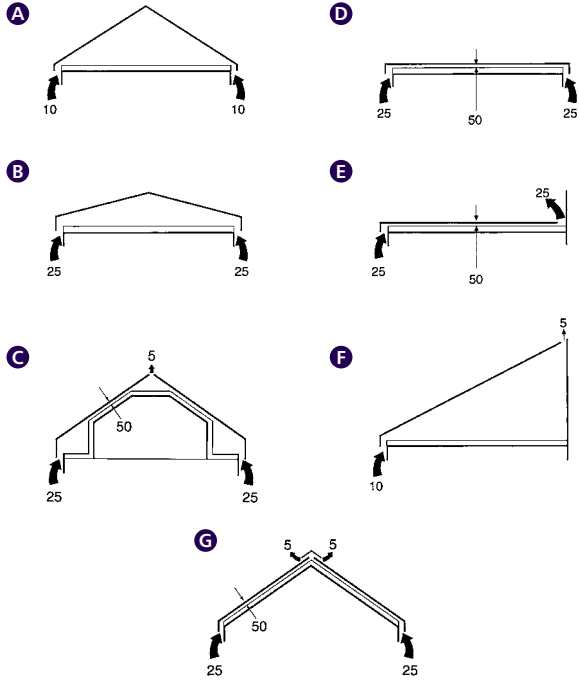

**EAVES AND SOFFIT VENTILATORS**

HD 8250

**B C D E G**

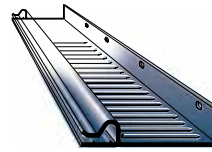

HD 12000M

**A F**

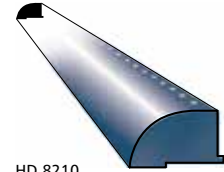

HD 8000

**A F**

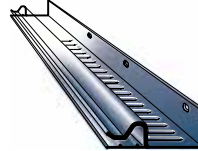

HD 8210

**A F**

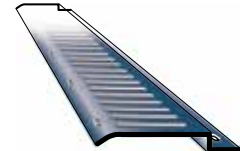

HD 12000U

**A B C D E F G**

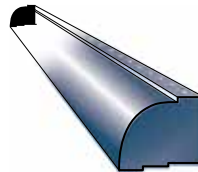

HD 7000

**A F**

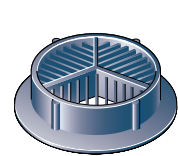

HD 8310 CORBEL VENTILATOR

**A F**

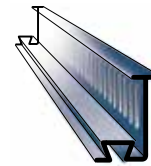

**EAVES PANEL VENTILATORS**

HD 4000, HD 4500 and HD 6000

**A B C F G**

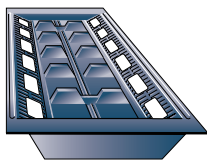

HD 5000 UNIVERSAL ROLL PANEL

**A B C F G**

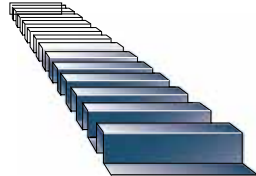

HD 4050, HD 4550 and HD 6050

**A F**

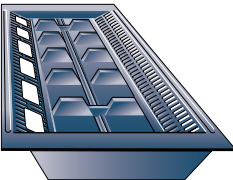

HD URT UNIVERSAL REFURBISHMENT TRAY

**A B C F**



HD 4025, HD 4525 and HD 6025

**B C G**

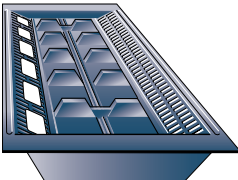

**DRY FIX RIDGE**

DFR3 DRY FIX RIDGE/VENTILATION SYSTEM

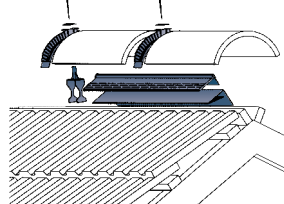

**TILE AND SLATE ROOF VENTILATORS**

HD TV15/1



HD TV15/2

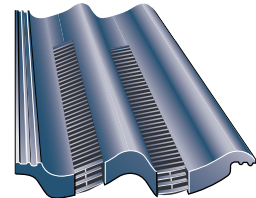

HD TV10/6

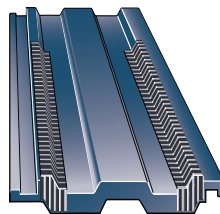

HD TV10/8

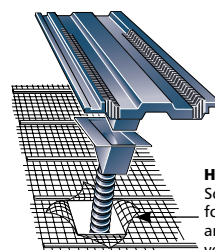
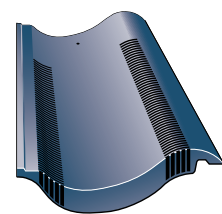

HD RSPA Soil pipe adapter for HD TV10/6 and HD TV10/8 ventilators

HD TV10/5

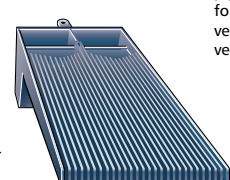

HD PCSPA Plain tile soil pipe adapter for HD TV10/5 ventilator – soil ventilation only





**CAVITY AND UNDERFLOOR VENTILATORS**

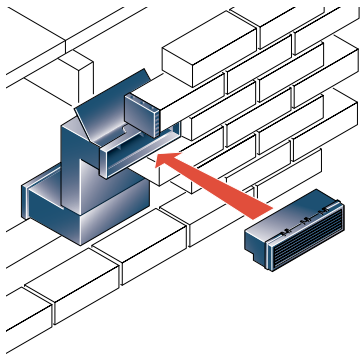

HD 9600M Telescopic Ventilator  
 HD 9600CT Cavity Tray  
 HD 9300 Airbrick Ventilator

Horizontal Extension Sleeves:-  
 HD 9660M (Bottom)  
 HD 9660T (Top)

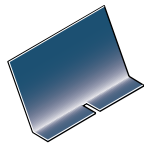

HD 9600CT  
Cavity Tray

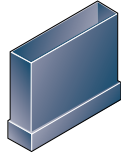

HD 9610/2  
Vertical Extension Sleeve



Horizontal Extension Sleeves:-  
 HD 9660M (Bottom)  
 HD 9660T (Top)

HD 9300  
COMBINATION AIR BRICK

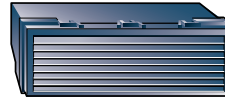

HD 9600B  
Factory Fitted VERMIN SCREEN



HD 96200  
SQUARE TO ROUND ADAPTER

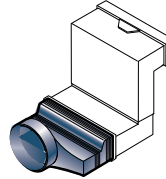

HD 9400/1/2/3  
INTERNAL VENT GRILLE



HD 9300G  
GAS VENT GRILLE



HD 9350/1  
AIRBRICK VENTILATOR SLEEVES

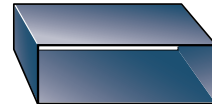

HD 9350/2  
AIRBRICK VENTILATOR SLEEVES

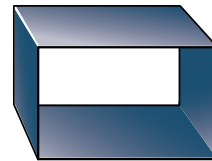

HD 9350/3  
AIRBRICK VENTILATOR SLEEVES

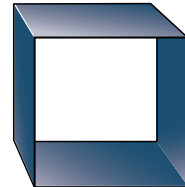

HD 9800  
LINTEL STOP END



HD 9100  
PERP WEEP

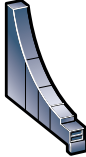

HD 9200  
Perp Weep Extension

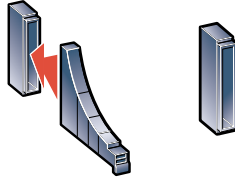

WEEP VENT  
HD 9500

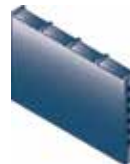

HD TV15/3

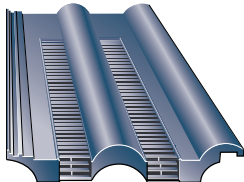

HD TV15/4

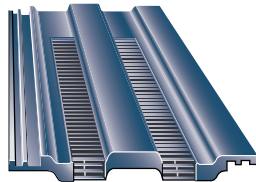

HD TV15/7

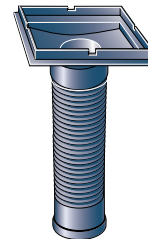
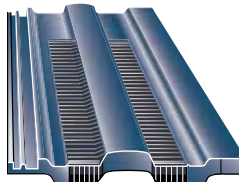

**TVSPA**  
Soil Pipe Adapter for use with HD TV15/1, HD TV15/2, HD TV15/3, HD TV15/4 and HD TV15/7 tile roof ventilators

HD SRV5U

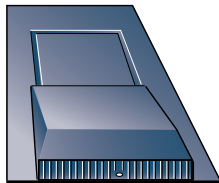

HD SRV10U

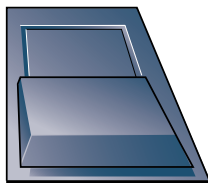

Also available  
HD SRV10/20

HD SRV680

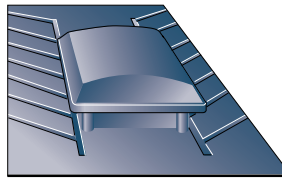

HD ILSRV10U

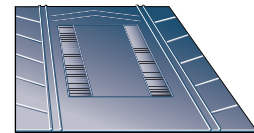

Soil Pipe Adapter Code HD ILSPA  
compatible for use with HD ILSRV10U  
slate roof ventilators

HD ILSRV10/20 and  
HD ILSRV10/24

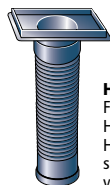
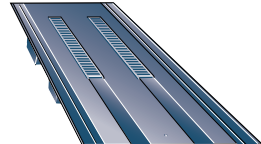

**HD ILSPA**  
For use with  
HD ILSRV10/20 &  
HD ILSRV10/24  
slate roof  
ventilators



**HD SPA680**  
For use with  
HD SRV680  
slate roof  
ventilators

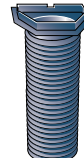

**HD SPA**  
For use with  
HD SRV10/U  
slate roof  
ventilators



**HD FPC**  
Flexi-pipe can  
be used as an  
extension to all  
HDL Soil Pipe  
Adapter Kits

Soffit Ventilators

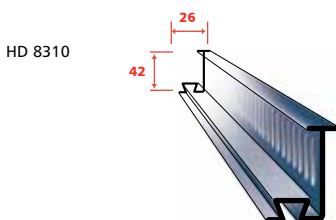
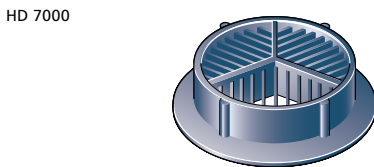
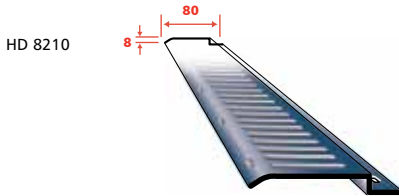
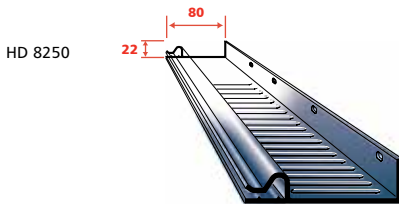
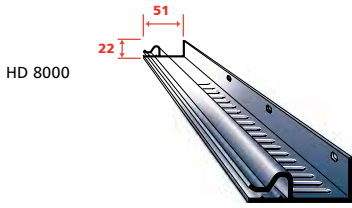

**SOFFIT VENTILATORS**  
HD 8000 & HD 8250

**USE:** Permits entry of air into roofspace in projecting soffit situations. When fitted on opposite sides of a rectangular roof structure will satisfy the requirements of the Building Regulations, e.g. front and rear elevations.

**ADVANTAGES:** Lightweight, easy to handle and fix strips. (Strips are punched with fixing slots.) Will support soffit boards between 4mm and 10mm in thickness, up to 300mm wide without additional noggins; provides

well in excess of the minimum required airflow. Ideal for new build applications.

**FLY SCREEN:** Recommended 4mm wide slots.

**AIRFLOW:**

HD 8000 = 10,000mm<sup>2</sup> per m. Roof pitch: above 15°.

HD 8250 = 25,000mm<sup>2</sup> per m. Roof pitch: below 15°.

**MATERIAL:** UV stabilised PVC.

**LENGTH:** 2.4 m strips.  
**COLOURS:** White and Brown. HD 8000 also in Black.

**SOFFIT VENTILATOR**  
HD 8210

**USE:** Permits entry of air into roofspace in projecting soffit situations. When fitted on opposite sides of a rectangular roof structure will satisfy the requirements of the Building Regulations, e.g. front and rear elevations.

**ADVANTAGES:** This ventilator is designed for use with sloping soffit situations, and may be butted up to brickwork when used without a soffit board. Other applications for this ventilator exist, for instance, in no fascia

situations, or at high level on a mono pitch roof. For further information contact our technical services department.

**FLY SCREEN:** Recommended 4mm wide slots.

**AIRFLOW:** 10,000mm<sup>2</sup> per metre run.

**MATERIAL:** PVCU.

**LENGTH:** 2.4 m

**COLOURS:** White and Brown.

**CIRCULAR SOFFIT VENTILATOR**  
HD 7000

**USE:** This vent, when introduced into existing unventilated soffit boards in refurbishment projects, will permit entry of air into the roof-space.

**ADVANTAGES:** Easily fitted into pre-drilled 70mm diameter holes. Standard flyscreen conforms to regulation requirements.

**AIRFLOW:**

Per vent (mm<sup>2</sup>) 2,500mm<sup>2</sup>

Vents per metre: 4

Fitted at centres: 250mm

Provides: 10,000mm<sup>2</sup> per metre.

**MATERIAL:** Polypropylene

**COLOURS:** White, Brown, Light Oak and Black.

**BASE DIAMETER:** 80mm

**CORBEL VENTILATOR**  
HD 8310

**USE:** To provide air ventilation at eaves level where a continuous masonry corbel of brick, stone or similar is constructed.

**BENEFITS:** The base at the rear of the ventilator has a dovetail anchoring slot which enables security ties to be positively attached at any position to suit the corbel masonry joints.

**AIRFLOW:** 10,000mm<sup>2</sup> per metre run.

**MATERIAL:** PVCU.

**LENGTH:** 2.4 m

**COLOUR:** Black.

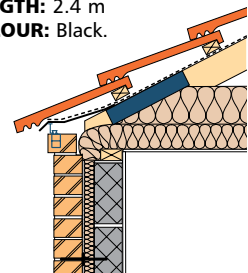

Over Fascia Ventilators

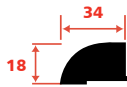
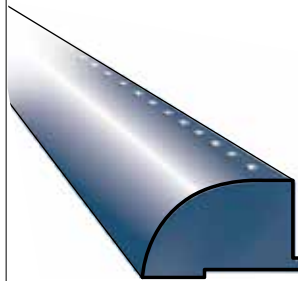
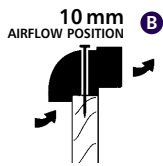
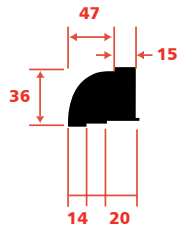
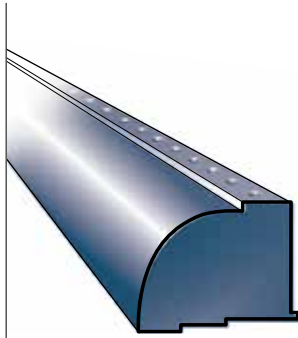

**UNIVERSAL OVER FASCIA VENTILATOR  
HD 12000U**

**USE:** To provide a through-flow of ventilating air over the fascia board in both new build and refurbishment details.

**ADVANTAGES:** Unique two stepped fixing positions to allow for use on roofs above and below 15° of pitch, allowing the through-flows of air at 25,000mm<sup>2</sup> and 10,000mm<sup>2</sup> per metre respectively. Reinforced nailing guides ensure accurate fixing to fascia and also for eaves comb filler. Standard flyscreen conforms to regulation

requirements. Rounded front section prevents blocking of airflow from overlapping underlay. Use with Hambleside Danelaw's range of Panel and Roll Panel ventilators.

**AIRFLOWS:**  
25mm position = 25,000mm<sup>2</sup> per metre.  
10mm position = 10,000mm<sup>2</sup> per metre.

**MATERIAL:** Black injection moulded polypropylene.  
**LENGTH:** 1m.

**OVER FASCIA VENTILATOR  
HD 12000M**

**USE:** To provide a through-flow of ventilating air over the fascia board in both new build and refurbishment details.

**ADVANTAGES:** Reinforced nailing guides ensure accurate fixing to fascia and also for eaves comb filler. Standard flyscreen conforms to regulation requirements. Rounded front section prevents blocking of airflow from overlapping underlay. Use with Hambleside Danelaw's

range of Panel and Roll Panel ventilators.

**AIRFLOW:** 10,000mm<sup>2</sup> per metre.

**MATERIAL:** Black injection moulded polypropylene.  
**LENGTH:** 1m.

**AIRFLOW DIAGRAMS**

HD 12000U

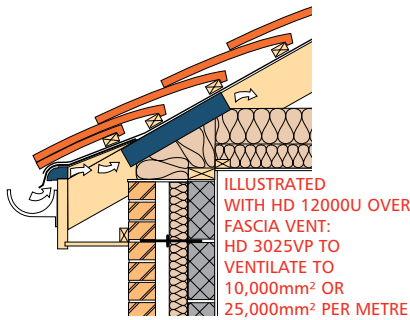

HD 8210

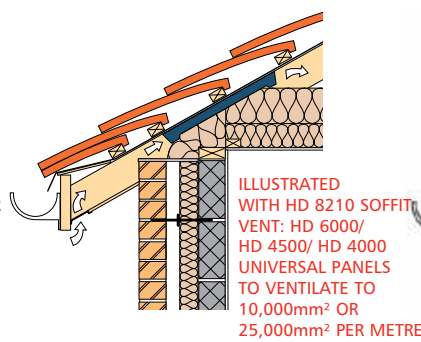

HD 8000

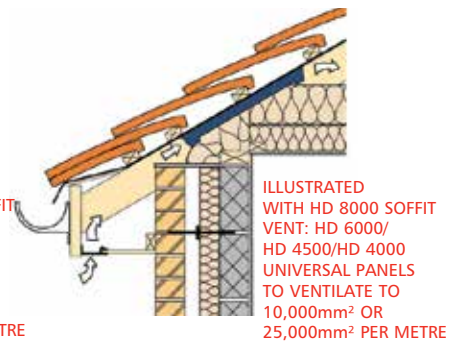

**AIRFLOW DIAGRAMS**

HD 8250

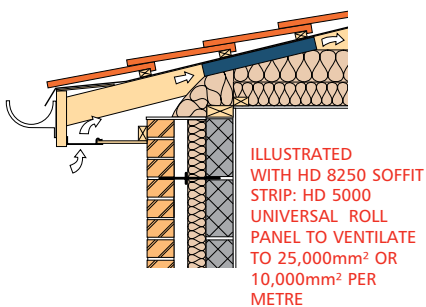

HD 7000

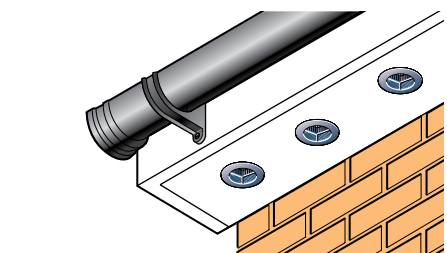
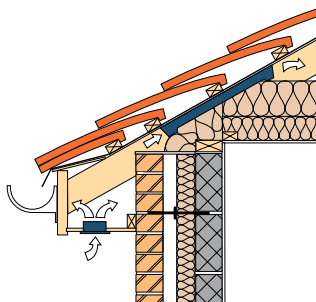

HD 7000 CIRCULAR SOFFIT VENTILATORS FORM AN ATTRACTIVE AND EFFECTIVE SOLUTION

Eaves Panel Ventilators

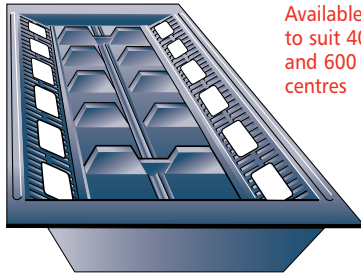

Available in 3 widths to suit 400 mm, 450 mm and 600 mm rafter centres

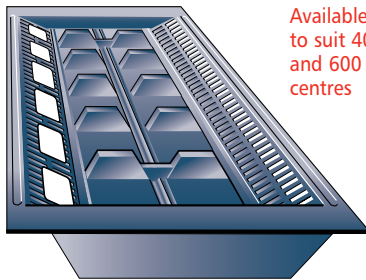

Available in 3 widths to suit 400 mm, 450 mm and 600 mm rafter centres

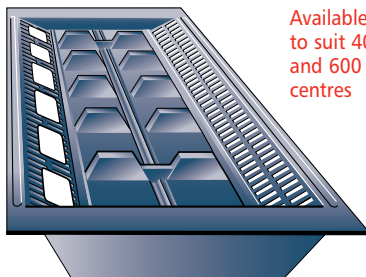

Available in 3 widths to suit 400 mm, 450 mm and 600 mm rafter centres

**UNIVERSAL PANEL VENTILATORS**  
HD 6000, HD 4500 & HD 4000

**USE:** In normal situations the insulation is laid up to and over the wall plate to avoid 'cold bridging'. In some cases this insulation can block the air circulation into the roofspace. The panel ventilator is fitted between the insulation and underlay and over the rafters to ensure a clear air passageway from the soffit into the roof space; use when the roof pitch is either below 15° or above 15°.

**ADVANTAGES:** Lightweight, easy to handle and fix panels; in three sizes to fit most rafter spacings; formed with ribs to ensure felt cannot drape into the panel and block airflow.

**HD 6000, HD 4500, HD 4000**

**AIRFLOW:**

	Per panel	Per metre
HD 6000	16,000mm <sup>2</sup>	29,090mm <sup>2</sup>
HD 4500	12,000mm <sup>2</sup>	30,000mm <sup>2</sup>
HD 4000	9,000mm <sup>2</sup>	25,714mm <sup>2</sup>

**MATERIAL:** PVC.  
**COLOUR:** Black

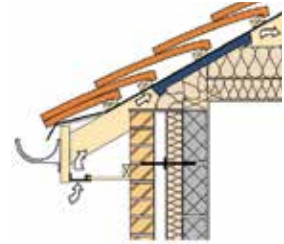

**SINGLE FLYSCREEN +15° PITCH**  
HD 6050, HD 4550, HD 4050

**USE:** For open eaves details, protruding flyscreen with recommended 4mm slots; use on roof pitches of 15° or above.

**FLYSCREEN PANELS:** The 6050 range of Panel Ventilators is available with a single row of slotted screen protection. These panels, when fitted to every rafter centre will provide the regulation requirement of a continuous 10mm gap at the eaves.

**HD 6050, HD 4550, HD 4050**  
flyscreen panels.

**AIRFLOW:**

	Per Panel	Per Metre
HD 6050	6,843mm <sup>2</sup>	12,441mm <sup>2</sup>
HD 4550	5,132mm <sup>2</sup>	12,830mm <sup>2</sup>
HD 4050	4,474mm <sup>2</sup>	12,782mm <sup>2</sup>

**MATERIAL:** PVC.  
**COLOUR:** Black.

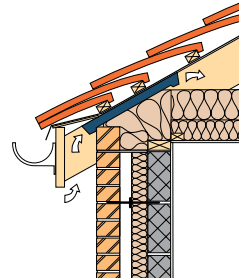

**DOUBLE FLYSCREEN -15° PITCH**  
HD 6025, HD 4525, HD 4025

**USE:** For open eaves details, protruding flyscreen with recommended 4mm slots; use on roof pitches below 15°.

**FLYSCREEN PANELS:** The 6025 range of Panel Ventilators is available with double rows of slotted screen protection. These panels, when fitted to every rafter centre will provide the regulation requirement of a continuous 25mm gap at the eaves.

**HD 6025, HD 4525, HD 4025**  
flyscreen panels.

**AIRFLOW:**

	Per Panel	Per Metre
HD 6025	13,786mm <sup>2</sup>	25,065mm <sup>2</sup>
HD 4525	10,264mm <sup>2</sup>	25,660mm <sup>2</sup>
HD 4025	8,948mm <sup>2</sup>	25,565mm <sup>2</sup>

**MATERIAL:** PVC.  
**COLOUR:** Black.

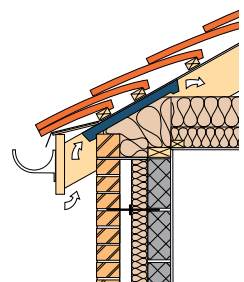

Eaves Panel Ventilators

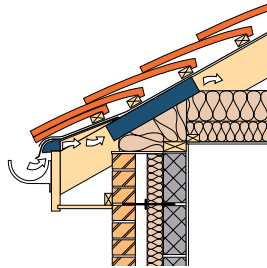
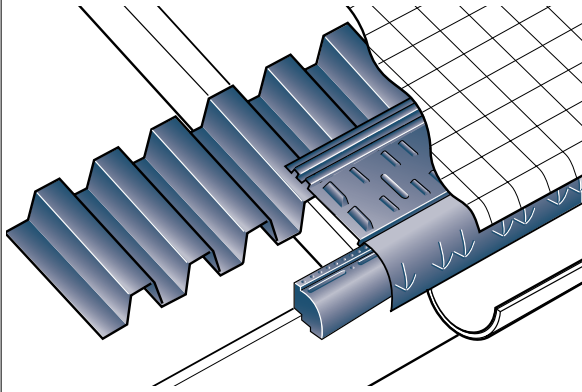

**3 IN 1 VENTILATOR PACK  
HD 3025VP**

The most cost effective and simple way of providing a complete ventilation and felt or underlay support system giving additional protection to the fascia detail of all roof types.

A unique feature of this system is the new Universal Over Fascia Ventilator with two fixing positions that adapt to 10mm and 25mm airflows.

HD 3025VP contains:

- 1 x 6 metre Roll Panel (HD 5000)
- 10 x 600mm Underlay Support Trays (HD 3000)
- 6 x 1 metre Over Fascia Vent (HD 12000U).

The products within the '3 in 1' pack are available separately.

THE HD 3000VP VENT PACK IS ALSO AVAILABLE WITH A STANDARD FIX 10,000mm<sup>2</sup> AIRFLOW OVER FASCIA VENTILATOR.

Installation of the HD 3025VP Vent Pack is straightforward. The Over Fascia Ventilator is fitted to the top edge of the fascia board, in either of the two stepped positions, to suit the required level of airflow and the Roll Panel and Underlay Support Tray are then installed.

The Underlay Support Tray is placed on top of the Over Fascia Ventilator and nailed into place through holes provided in the over fascia vent. This will make it much easier to locate alternative nail holes if an Eaves Comb Filler is to be fitted. It is then nailed at the top edge of the tray through the Roll Panel if required and into the rafter. Consecutive trays are lapped by 50mm using the raised locators formed into the tray sides. The Underlay Support Tray forms the drip into the gutter.

**AIRFLOWS:**  
25mm fixing position = 25,000mm<sup>2</sup> per metre  
10mm fixing position = 10,000mm<sup>2</sup> per metre

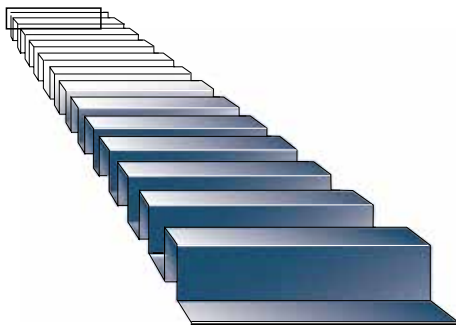

**ROLL PANEL VENTILATOR  
HD 5000**

**USE:** Prevents insulation blockage at eaves and allows high levels of cross flow ventilation – eaves to eaves. Use in conjunction with the Hambleside Danelaw range of soffit ventilators to achieve full eaves to eaves airflow.

**ADVANTAGES:** Universal rafter centre fitting capability. Conforms to 10mm and 25mm requirements.

**AIRFLOW:** 25,000mm<sup>2</sup> per metre  
**MATERIAL:** PVC.  
**COLOUR:** Black.  
**LENGTH:** 6 metre rolls.



**UNIVERSAL REFURBISHMENT TRAY VENTILATOR  
HD URT**

**USE:** A rafter tray specifically designed for installation into the eaves of a completed and traditionally constructed tiled or slated roof. Inserted to ensure that insulation blockage of the path of air necessary to ventilate the roof space does not occur.

If no means of introducing air through the soffit or over fascia exists the HD 7000 Circular Soffit can be fitted retrospectively into the soffit board.

**BENEFITS:** A universal refurbishment tray designed to be used either as a single panel to rafter centres of 450mm or below 450mm by trimming the panel to suit. For rafter centres between 450mm and 600mm the panel can be extended by cutting a second panel in half and connecting the two together.

**AIRFLOW:** 25,000mm<sup>2</sup> per metre  
**MATERIAL:** PVC.  
**COLOUR:** Black.

Slate Roof Ventilators



**UNIVERSAL SLATE ROOF VENTILATOR**  
**HD SRV5U**

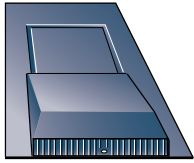

**USE:** Universal slate roof ventilator for use with man-made or natural slates.  
**ADVANTAGES:** Long life, simple to install with minimum cutting of slates. UV light and acid rain resistant. Colour through material – stable at temperatures of -40°C to +120°C.

**MATERIAL AND SIZE:** Polypropylene in Black. Grey to order. Will fit either 600 x 300mm or 500 x 250mm slates.  
**AIRFLOW:** 5,000mm<sup>2</sup> actual ventilation area.

*Minimum rafter pitch: 22.5° or 25° depending on head lap.*

**SLATE ROOF VENTILATOR**  
**HD SRV680**

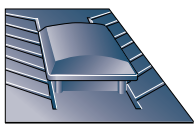

**USE:** Slate roof ventilator for use with man-made or natural slates.  
**ADVANTAGES:** Long life, simple to install with minimum cutting of slates. UV light and acid rain resistant. Large base for 'random' slate roofs with a

facility for trimming to 600 x 300mm. Stable at temperatures of -40°C to +120°C.

May be used for soil ventilation and mechanical extraction when fitted with the HD SPA680 soil pipe adapter kit.

**MATERIAL:** Polypropylene in Black. Grey to order.  
**AIRFLOW:** 20,000mm<sup>2</sup> actual ventilation area.

**ACTUAL BASE SIZE:** 452mm wide x 682mm deep.

**NOTE:** Roofing underlay preparation to be in accordance with HD ILSRV's.

**HD SPA680** For use with HD SRV680 slate roof ventilators.

**USE:** Connecting 110mm soil vent pipe outlet to 10,000mm<sup>2</sup> area ventilator.

**ADVANTAGES:** May be used for mechanical extraction when fitted to HD SRV680 vents. Length = 500mm.

**AIRFLOW:** Total through ventilation area for the adapter is 8,000mm<sup>2</sup>.

**Adapters only available.**

*Minimum rafter pitch: 22.5° or 25° depending on head lap.*

**UNIVERSAL SLATE ROOF VENTILATOR**  
**HD SRV10U**

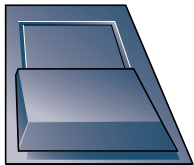

**ALSO AVAILABLE**  
**HD SRV10/20**  
500 x 250mm base size -  
10,000mm<sup>2</sup> actual vent area

**USE:** Universal slate roof ventilator for use with man-made or natural slates.

**ADVANTAGES:** Long life, simple to install with minimum cutting of slates. UV light and acid rain resistant. Colour through material – stable at temperatures -40°C to +120°C.

**MATERIAL AND SIZE:** Polypropylene in Black. Grey to order. Will fit either 600 x 300mm or when trimmed, 500 x 250mm slates.

**AIRFLOW:** 10,000mm<sup>2</sup> actual ventilation area. Adapter available for soil pipe ventilation and mechanical extraction.

**HD SPA** For use with HD SRV10U and HD SRV10/20 slate roof ventilators.

**USE:** Connecting 110mm soil vent pipe outlet to 10,000mm<sup>2</sup> area ventilator.

**ADVANTAGES:** May be used for mechanical extraction when fitted to compatible vents. Length = 500mm.

**AIRFLOW:** Total through ventilation area for the adapter is 8,000mm<sup>2</sup>.

**Adapters only available.**

*Minimum rafter pitch: 22.5° or 25° depending on head lap.*

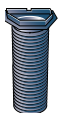

**HD SRV5U, HD SRV10U & HD SRV10/20**

Hambleside Danelaw Limited surface ventilators require the underlay to be cut to an inverted 'T' shape ensuring a close snug fit to the vent spigot or aperture. The cuts forming the 'T' should be folded up and back to deflect moisture and debris away from the cut hole in the underlay. This careful preparation will assist in preventing water penetration should other problems exist above the line of the vent, i.e. excessive condensation, cracked / broken or missing slates, etc.

**FLUSH FITTING SLATE ROOF VENTILATOR**  
**HD ILSRV10/20 & HD ILSRV10/24**

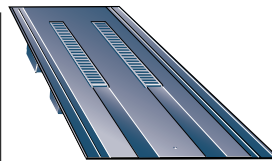

**USE:** A flush fitting slate roof ventilator, for use with natural or man-made slates, available in both 600 x 300mm and 500 x 250mm slate sizes providing discreet air entry through the roof surface as well as providing

for both mechanical and soil extraction via additional adapters. No batten cutting is needed with these ventilators.

**MATERIAL:** Black polypropylene for durability and thermal stability (Grey to order); with non-reflective surface; fully UV stabilised. Stable at temperatures of -40°C to +120°C.

**AIRFLOW:** 10,000mm<sup>2</sup> actual ventilation area.

**HD ILSRV10/20**

Base size 565 x 290mm to suit 500 x 250mm slate size.

**HD ILSRV10/24**

Base size 615 x 300mm to suit 600 x 300mm slate size.

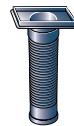

**Soil Pipe Adapter kit ILSPA. (Includes Flexi-Pipe Connector and Blanking Plug)**  
**Adapter only available.**

*Minimum rafter pitch: 22.5° or 25° depending on head lap.*

**FLUSH FITTING SLATE ROOF VENTILATOR**  
**HD ILSRV10/U**

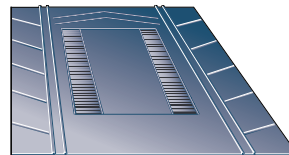

**USE:** Slate roof ventilator for use with man-made or natural slates.

**ADVANTAGES:** Long life, simple to install with minimum cutting of slates. Suitable for both batten and sark board fixing. UV light and acid rain resistant.

This universal slate ventilator is unique and available for use with the following slate sizes: 600 x 300mm, 500 x 250mm, 450 x 230mm. Stable at temperatures of -40°C to +120°C. May be used for soil ventilation and mechanical extraction when fitted with the HD SPA soil pipe and adapter plate.

**MATERIAL:** Polypropylene in Black. Grey to order.

**AIRFLOW:** 10,000mm<sup>2</sup> actual ventilation area.

**ACTUAL BASE SIZE:** 400mm wide x 454mm deep.

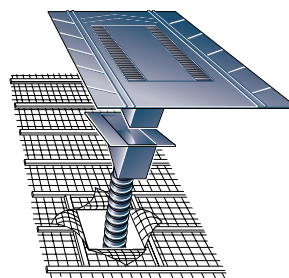

**HD ILSRV10/U** Shown here with the Soil Pipe Adapter kit HD ILSPA.

**Adapter only available.**

*Minimum rafter pitch: 22.5° or 25° depending on head lap.*

Tile Roof Ventilators



**Hambleside Danelaw Recommendations**

Hambleside Danelaw Limited recommends, in accordance with recognised good tiling practice, that all interlocking tiles should be laid as close to the mid shunt position as possible. Tiles laid too closely together cannot always accommodate the expansion and contraction of the tiles and the roof structure below; this could result in the possibility of the tiles lifting and the interlocks cracking. Likewise, the tile vents may also lift or distort under the compression forces created.

Should difficulty occur in providing conventional cross flow ventilation at eaves level, when maintaining insulation thickness to avoid cold bridging for example, Hambleside Danelaw Limited recommends the use of slate or tile vents positioned as close to eaves level as possible whilst ensuring that they are located above the level of the internal insulation layers.

All Hambleside Danelaw roof ventilation products are suitable for use when the vapour tightness of the ceiling, or the sealing of all joints in and penetrations through VPUs in non-ventilated roof constructions, cannot be achieved or maintained for the life of the roof.

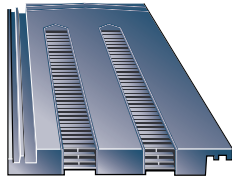

HD TV15/1

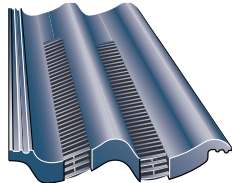

HD TV15/2

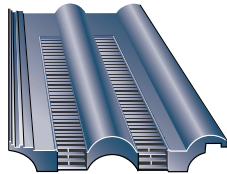

HD TV15/3

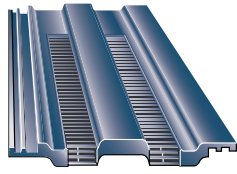

HD TV15/4

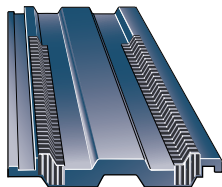

HD TV10/6

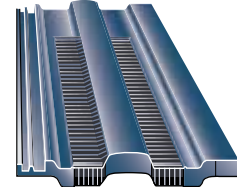

HD TV15/7

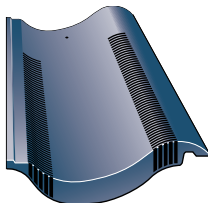

HD TV10/8

**TILE TYPE TO VENTILATOR COMPATIBILITY**

**HD TV15/1 TILE VENT**

Marley Modern Type  
Redbank Bretton Type  
Redland Mini Stonewold Type  
Russells Grampian Type  
Sandtoft Calderdale Type  
Quinn Western Slate MK 2 Type  
Lagan Flat Type

**HD TV15/2 TILE VENT**

Marley Mendip Type  
Redland Grovebury Type  
Russell Pennine Type  
Quinn Locherne Type

**HD TV15/3 TILE VENT**

Marley Double Roman Type  
Redland Double Roman Type  
Russells Double Roman Type  
Sandtoft Double Roman Type  
Lagan Double Roll Type

**HD TV15/4 TILE VENT**

Marley Ludlow Major Type  
Russells Cheviot Type

**HD TV10/6 TILE VENT**

Marley Ludlow Plus Type  
Redland 49 Type  
Sandtoft Standard Pattern Type

**HD TV15/7 TILE VENT**

Redland Renown Type

**HD TV10/8 TILE VENT**

Marley Anglia Plus Type  
Redland Norfolk Pantile Type  
Sandtoft Shire Pantile Type

**ALL HD TV's AND HD ILSRV's**

Hambleside Danelaw Limited surface ventilators require the underlay to be cut diagonally to form an envelope ensuring a close snug fit to the vent spigot or aperture. The cuts forming the envelope should be folded up and back to deflect moisture and debris away from the cut hole in the underlay. This careful preparation will assist in preventing water penetration should other problems exist above the line of the vent, i.e. excessive condensation, cracked / broken or missing slates or tiles, etc.

**TILE ROOF VENTILATORS**

**HD TV15 SERIES & HD TV10 SERIES**

**USE:** Designed for use with the most popular tile profiles, they provide attractive but discreet ventilation entry through the roof surface. With the use of additional adapters they can be fully utilised for both mechanical extraction and soil ventilation.

**MATERIAL:** Manufactured from polypropylene for durability and thermal stability, they have a non-reflective surface and are UV stabilised to prevent embrittlement through age.

**COLOURS:** The standard

through-colour range consists of Terracotta, Brown, Grey and Antique Red although other specific colours are available to order.

**VENT AREA:** Each tile has an actual ventilation area of:  
HD TV15/1 – 15,000mm<sup>2</sup>  
HD TV15/2 – 15,000mm<sup>2</sup>  
HD TV15/3 – 15,000mm<sup>2</sup>  
HD TV15/4 – 15,000mm<sup>2</sup>  
HD TV15/7 – 15,000mm<sup>2</sup>  
HD TV10/6 – 10,000mm<sup>2</sup>  
HD TV10/8 – 10,000mm<sup>2</sup>  
HD TV10/5 – 2,000mm<sup>2</sup>

**SOIL PIPE ADAPTER KITS**

**USE:** Connecting 110mm diameter pipes for soil ventilation and mechanical extraction.

**Hose:** 510mm Long

**AVAILABLE AS:** Complete adapter kits Code: HD TVSPA for HD TV15 range and HD RSPA for the HD TV10 range. **Adapters only available.**  
**VENT AREA:** 8,000mm<sup>2</sup> per unit.

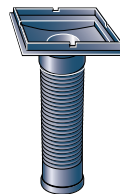

**HD TVSPA** Tile vent adapter kit for use with HD TV15/1, 15/2, 15/3, 15/4 and 15/7 ventilators.

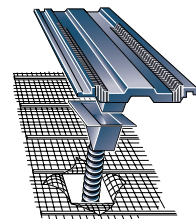

**HD RSPA** Tile vent adapter kit for use with HD TV10/6 and 10/8 range of ventilators.

**PLAIN TILE ROOF VENTILATOR**

**HD TV10/5**

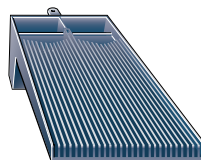

**MATERIAL:** Manufactured from polypropylene for durability and thermal stability. The vent has a non-reflective surface and is UV stabilised to prevent colour loss and embrittlement through age.

**COLOURS** Standard colour range of Terracotta, Brown, Antique Red, and Grey. Special colours to order.

**VENT AREA** 2,000mm<sup>2</sup>

actual ventilation area per tile ventilator.

**USE:** Fitted in groups of 5 to achieve regulation 10,000mm<sup>2</sup> per metre.

**HD PCSPA** Tile vent adapter kit for soil ventilation use only with HD TV10/5 ventilator in pairs. Adapters only available.

**ES10/5** Extension spigots available for fully boarded roofs (not shown).

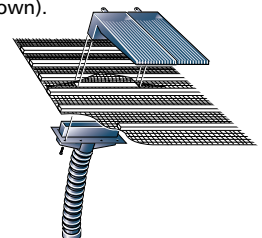



## Dry Fix Ventilated Ridge Systems

### UNIVERSAL DRY FIX VENTILATED RIDGE SYSTEM HD DFR3

**USE:** A universal Dry Fix ridge system that can be used with all commonly available ridge, tiles and slate types.

**ADVANTAGES:** Can be fitted in all weathers and to all roof pitches with no special tools required. The system has a minimum number of components, is simple and quick to install with no reliance on adhesive strips. Provides a secure fixing against the weather with easy ridge alignment and discreet appearance.

Supplied 3 linear metres per pack.

**AIRFLOW:** DRF3 provides 5,000mm<sup>2</sup> airflow area per linear metre to both roof slopes making it ideally suited to cold and warm roofs and for batten space ventilation.

Commonly used as a Dry Fix Ridge installation kit where ventilation is not required.

#### DRF3 Installations

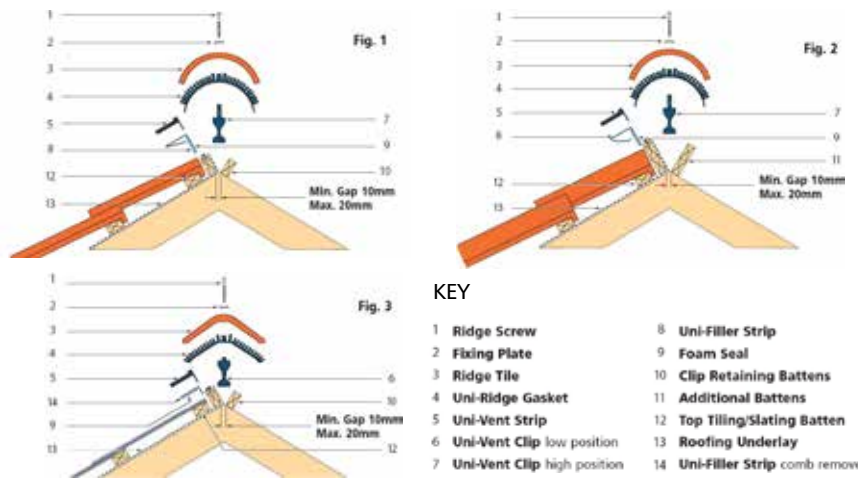

#### DRF3 Components

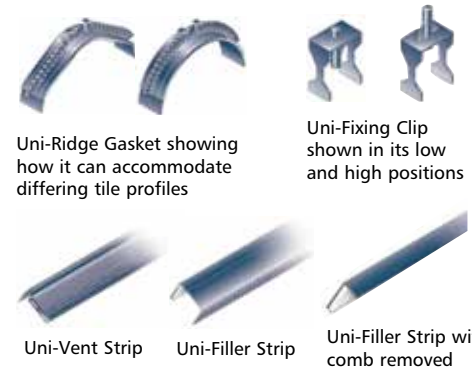

### UNIVERSAL ROLLOUT RIDGE AND HIP SYSTEM HD ROR3 AND HD ROR6

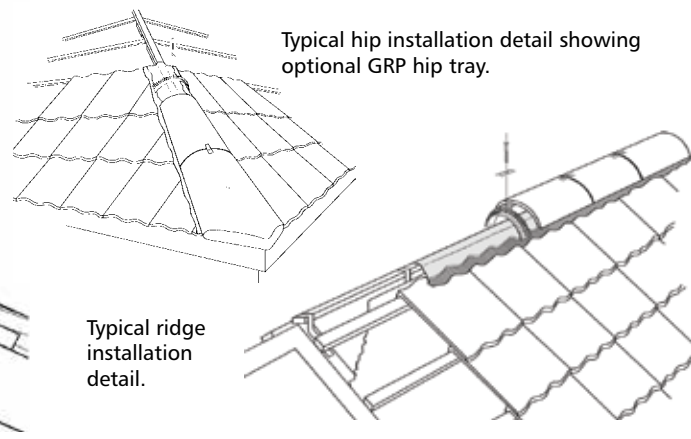
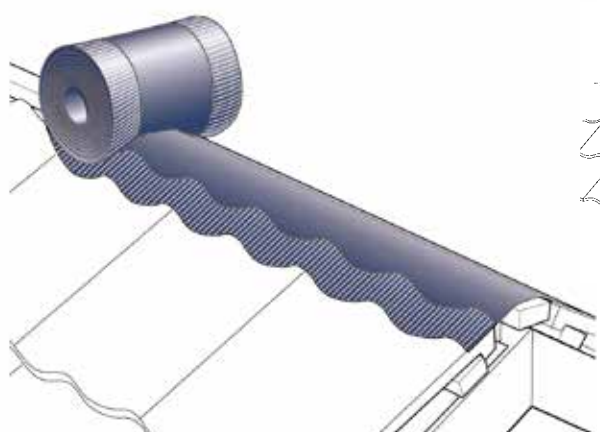

**USE:** A universal Dry Fix ridge and hip system that can be used with all commonly available ridge, tiles and slate types.  
**ADVANTAGES:** Can be fitted to all roof pitches with no special tools required. The single unique universal jointing gasket adds flexibility and allows compatibility with most commonly available ridge and hip tile profiles. Broader corrugations than other similar systems at the edge of the RollOut accommodate more types of ridge design and different pitches of roof. Suitable for Hip and Ridge applications. Clips for hip tile cuts provided separately if required.  
 RollOut is available in either 6m (HD ROR6) or 3m (HD ROR3) packs to suit all requirements, large or small.

**AIRFLOW:** HD ROR3 & HD ROR6 provides 5,000mm<sup>2</sup> airflow area per linear metre making it ideally suited to cold and warm roofs and for batten space ventilation.  
**OPTIONAL HIP TRAY**  
 1.65m long, available in packs of 10, code **HDL HT165**. Also available in 3m length **HDL HT300**.  
**OPTIONAL TILE CLIP** (code: **HD DVC**) available for connecting small cuts of interlocking tiles on all Dry Fix hip systems.

Telescopic Ventilators and Airbricks

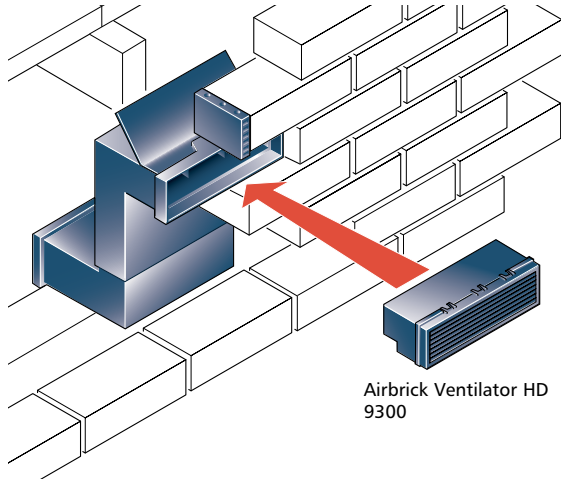

Airbrick Ventilator HD 9300

Telescopic Underfloor Ventilator HD 9600M



Telescopic Underfloor Ventilator HD 9600B with factory fitted Vermin Screen

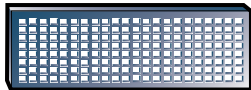

**TELESCOPIC UNDERFLOOR VENTILATOR HD 9600M**

**USE:** Designed to be used where the external vent aperture is required to be at a higher level than the underfloor void.

**ADVANTAGES:** Telescopic design gives adjustment from 3 to 5 course height of brickwork (down to 2 if trimmed), and a free airflow in excess of 7,000mm<sup>2</sup> per unit.

**USE WITH:** Factory fitted optional vermin screen Code HD 9600B. Separate optional cavity tray attachment Code HD 9600CT. Separate optional weep ventilator Code HD 9500.

**MATERIAL:** Injection moulded in black polypropylene.

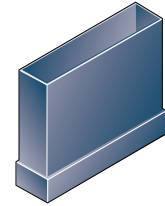

**Vertical Extension Sleeve: HD 9610/2**

A two course vertical extension sleeve for the HD 9600M. Can be used in multiples to achieve any desired height.

**Horizontal Extension**



**Sleeve:** Designed to extend the reach of the underfloor vent for varying cavity and wall leaf widths.

**Top extension sleeve: HD 9660T** 140mm long for an outer leaf width up to 170mm.

**Bottom extension sleeve: HD 9660M** 155mm long for an inner leaf width up to 215mm.

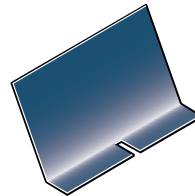

Optional Cavity Tray HD 9600CT



Combination Brick Ventilator HD 9300

**COMBINATION BRICK VENTILATOR HD 9300**

**USE:** Permits high levels of ventilation through walls. Provides entry of air into underfloor voids of suspended floors when used with the Telescopic Ventilator.

**ADVANTAGES:** Standard brick size, ingress protection from driving rain and large insects (4mm flyscreen). Ventilation area in excess of 7,000mm<sup>2</sup>. Bricks may be clipped together for 225 x 150mm or 225 x 225mm combinations.

**MATERIAL:** Injection moulded in polypropylene UV stabilised.

Buff, Brown – other colours to special order.  
**ACTUAL SIZE:** 219 x 79mm.

**GAS VENTILATOR GRILLE HD 9300G** Factory Fitted Option

**USE:** HD 9300G gas ventilator to meet with the aperture grille requirement of BS5440-2:2000, section 4 : 1 : 1 : 2 e.g. prevents the entry of a 10mm diameter ball, but allows entry of a 5mm diameter ball. The actual ventilation area of 7,500mm<sup>2</sup> is depicted on the front of each grille.

**COLOURS:** Black, Terracotta,

**AIRBRICK VENTILATOR SLEEVES HD 9350/1, HD 9350/2 & HD 9350/3**



**Air Brick Ventilator Sleeves HD 9350/1/2/3**

Available for one, two and three airbrick combinations  
Length: 280mm

**USE:** Semi rigid sleeve designed to ventilate through a standard cavity wall.

**ADVANTAGES:** Accommodates the 'clip-together' facility of HD 9300 Air Brick to achieve one, two or three brick fitting.

**MATERIAL:** Moulded Black polypropylene.  
**COLOURS:** Brown and White

**INTERNAL VENTILATOR GRILLE SIZES**

- HD 9400/1 – 225 x 75mm
- HD 9400/2 – 225 x 150mm
- HD 9400/3 – 225 x 225mm



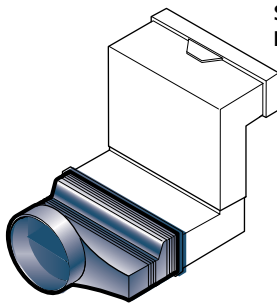

Square to Round Adapter  
HD 9620

**SQUARE TO ROUND ADAPTER  
HD 9620**

**USE:** Designed to fit the Telescopic Vent to enable standard 110mm plastic pipes to be connected to allow ventilation to remote underfloor voids.

**MATERIAL:** Polyethylene

Asymmetric design suitable for use immediately below pre-cast concrete floors.

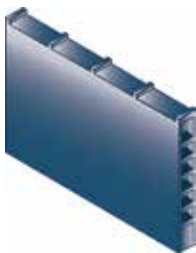

Weep Vent  
HD 9500

**UNIVERSAL WEEP VENTILATOR  
HD 9500**

**USE:** Provides ventilating air into the cavity, and when used with cavity tray DPC detailing, allows moisture permeating the cavity area to be returned to the outside.

moisture channel prevents ingress of mortar. Louvre grilles prevent ingress of insects and driven rain.

**AIRFLOW:** 260mm<sup>2</sup> per vent.  
**MATERIAL:** Injection moulded polypropylene, UV stabilised.

**ADVANTAGES:** Wall weep and cavity ventilator in the same product. Ideal for all standard detailing – window/door lintels or with airbricks for underfloor/ through cavity venting. Unique internal design allows fitting in either direction. Sealed base of

**COLOURS:** White, Black, Buff, Terracotta, Brown, Grey and Translucent.

Suitable for traditional build and timber frame construction.

Perp Weep  
HD 9100

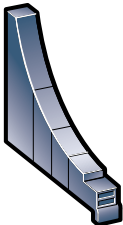

Perp Weep Extension  
HD 9200

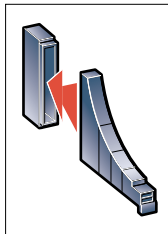

**PERP WEEP  
HD 9100**

**USE:** Allows the release of moisture above lintels and cavity trays.

**SIZE:** Height = 70mm  
Length = 100mm.

**MATERIAL:** Polypropylene.  
**COLOURS:** Translucent, Buff, Terracotta

**PERP EXTENSION  
HD 9200**

**USE:** Perp Weep Extension clips to the Perp Weep singularly or in multiples to accommodate different outer leaf constructions – e.g. render of different thicknesses.

**SIZE:** Height = 70mm  
Length = 30mm.

**MATERIAL:** Polypropylene.



Lintel Stop End  
HD 9800

**LINTEL STOP END  
HD 9800**

**USE:** A lintel stop end for use at the ends of most popular DPC steel lintels. The HD 9800 provides a stop end preventing discharge of water into the cavity.

**USE WITH:** HD 9800 Lintel Stop Ends may also be applied to a range of cavity trays. Now recommended by the NHBC and BS 8215 1991.

**BENEFITS:**

- Adjustable to most shapes and types of lintels for a secure fit.
- Ensures consistent and compliant build detail.
- Integral bonding strip on the base.

**MATERIAL:** Polypropylene.

**APPLICATIONS**

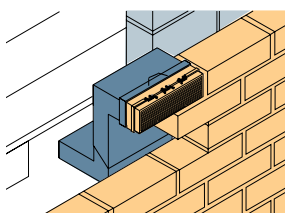

Telescopic Underfloor Vent  
HD 9600M

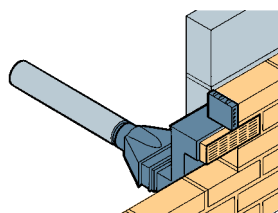

Square to Round Adapter  
HD 9620

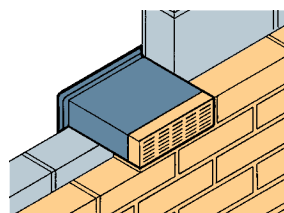

Airbrick/Sleeve HD 9300 and  
HD 9350

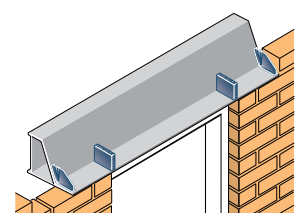

Weep Vent and  
Stop End Assembly



**PRODUCT VERIFICATION**

**NFRC** Hambleside Danelaw are Associate Manufacturing Members of the National Federation of Roofing Contractors and also participate in the Co-Partnership Guarantee Scheme.

**BCL** Birmingham City Laboratories (formerly Industrial Research Laboratories) certification available from tests carried out on GRP products, Tile Ventilator and Slate Ventilator ranges.

**Rapra Technology Limited** Independent tests carried out on the performance of Hambleside Danelaw GRP. Copies of the report are available on request from our Daventry office

Dry Fix mortarless GRP Valley Trough creates close-cut appearance on new build and refurbishment. Suitable for all profiled tiles. Available in standard lead grey colour, this unique product cuts fixing time by up to 50%. GRP valley troughs provide the following advantages over lead products

- Up to half the cost of traditional lead installation
- Semi-skilled fitting procedure
- Reduce installation time and cost by up to 50%
- Pre-formed profiles are light in weight and easy to handle
- BBA approved
- 30 year guarantee
- Third party testing accreditation by RAPRA Technology and Birmingham City Laboratories
- Does not streak or stain slates or tiles
- Can be safely used with other products to recycle rainwater
- No value to the thief

**DRY FIX VALLEY TROUGH FOR SLATE ROOFS**  
**HDL DVS/1 & 2**

Dry Fix Valley Trough for slate roof applications.

UK Patent No. 2307922

Supplied in packs of 5 units in either 2.4 or 3m lengths.

**HDL DVS/1** x 3000mm – lead grey  
**HDL DVS/2** x 2400mm – lead grey

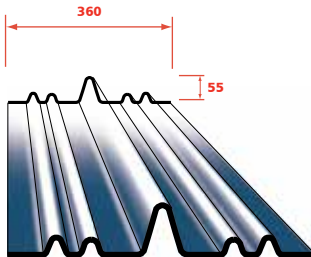

**DRY FIX VALLEY FOR PLAIN/LOW PROFILE TILES**  
**HDL DVLPT/1 & 2**

Dry Fix Valley Trough for plain and low profile tiles.

UK Patent No. 2307922

Supplied in packs of 5 units in either 2.4 or 3m lengths.

**HDL DVLPT/1** x 3000mm – lead grey  
**HDL DVLPT/2** x 2400mm – lead grey

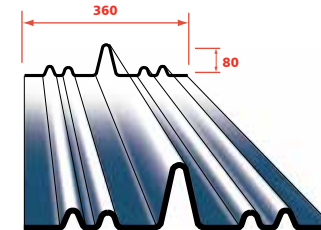

**DRY FIX VALLEY FOR HIGH PROFILE TILES**  
**HDL DVT/1 & 2**

Dry Fix Valley Trough for high profile tiles.

UK Patent No. 2307922

Supplied in packs of 5 units in either 2.4 or 3m lengths.

**HDL DVT/1** x 3000mm – lead grey  
**HDL DVT/2** x 2400mm – lead grey

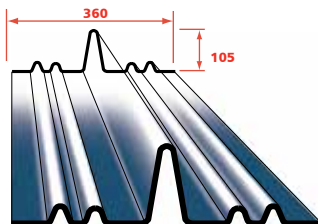

**SMALL CUT TILE SUPPORT BRIDGE**  
**HD DVBP**

In the case of interlocking single lap tiles, where small cuts of tiles occur, with HDL DVT and HDL DVLPT Valleys. The smaller cut section may need to be supported using a 'support bridge' UK Patent No. 2307922, positioned over the inner water bar.

Alternatively a stainless steel tile clip, **HD DVC**, may be used as illustrated. This support should only be required on the left side of the valley where no support is available from the tile interlock, ref. BBA Certificate No. 87/1915.

HD DVBP

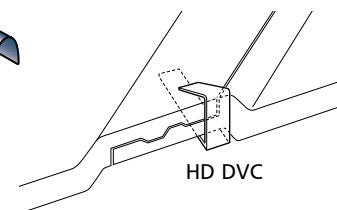



# Stormforce 225® High Performance Valley Troughs



**Our range of Stormforce 225® high performance open valley troughs comply with NFRC Technical Bulletin 28.**

## TILE VALLEY TROUGHS HDL 401, 402, 361 & 362

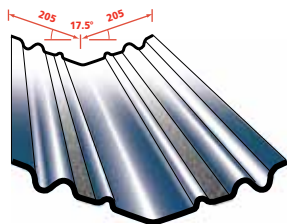

A popular valley trough incorporating mortar retention bars adjacent to the bonding strip.

Supplied in packs of 10 units.

**HDL 401** Standard lead grey W410mm x L3000mm  
**HDL 402** Standard lead grey W410mm x L2400mm

**Also available 380mm wide –**

**HDL 361** Standard lead grey W380mm x L3000mm  
**HDL 362** Standard lead grey W380mm x L2400mm

## TILE VALLEY TROUGHS HDL RP3 & HDL RP4

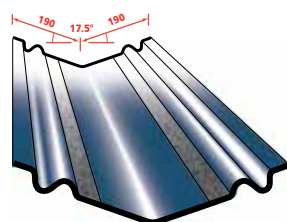

A basic 'contract' valley trough with mortar bonding strips.

Supplied in packs of 10 units.

**HDL RP3** Standard lead grey W380mm x L3000mm  
**HDL RP4** Standard lead grey W380mm x L2400mm

## SLATE VALLEY TROUGHS HDL SVTU & HDL SVT

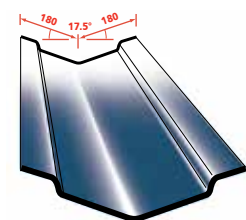

Designed for use with both natural or man-made slates.

**HDL SVTU** For slate roofs  
Supplied in packs of 10 units  
W360mm x L3000mm

**Also available 330mm wide**  
**HDL SVT** For slate roofs  
Supplied in packs of 10 units.  
W330mm x L3000mm

## SCOTTISH SLATE VALLEY TROUGH HDL SSVT

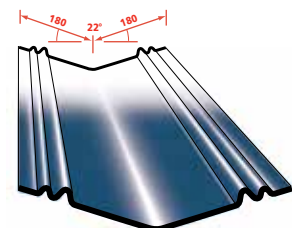

Designed specifically for a traditional boarded roof detail, this unique valley trough is fitted directly to the sarking board. For roof areas of less than 25m<sup>2</sup> and rafter pitches from 22.5° to 49°.

Supplied in packs of 10 units.

**HDL SSVT**  
Scottish Slate Valley Trough  
W360mm x L3000mm

### CHOOSING THE RIGHT VALLEY TROUGH PROFILE

Rafter Pitch (degrees)	Roof area less than 25 m <sup>2</sup>		Roof area from 25m <sup>2</sup> to 100m <sup>2</sup>		Minimum Lap Length (mm)
	Required Valley Product Code	Maximum Length (m)	Required Valley Product Code	Maximum Length (m)	
17.5 to 22	401/2 SVTU	7.0	Not applicable	Not applicable	350
22.5 to 29	RP3/4, 361/2, 401/2, SVT, SVTU	7.0	401/2, SVTU	14.5	300
30 to 34	RP3/4, 361/2, 401/2, SVT, SVTU	7.5	401/2, SVTU	15.0	200
35 to 39	RP3/4, 361/2, 401/2, SVT, SVTU	7.5	401/2, SVTU	15.5	200
40 to 44	RP3/4, 361/2, 401/2, SVT, SVTU	8.0	401/2, SVTU	16.5	150
45 to 49	RP3/4, 361/2, 401/2, SVT, SVTU	8.5	401/2, SVTU	17.0	150
50 to 55	401/2, SVTU	9.0	401/2, SVTU	18.5	150



**GUIDANCE NOTES ON VALLEY TROUGH INSTALLATION**

Guidance notes on valley trough installation can be found in the following publications, particularly with reference to valley board construction, the use of underlay and counter battens.

BS 5534:2003  
BBA Certificate No. 87 / 1915  
NFRC Technical Bulletin No. 28

**DRY FIX VALLEY FOR HIGH PROFILE TILES**  
HDL DVT/1 & 2

- |                 |                  |
|-----------------|------------------|
| 1 Tiles         | 4 Valley Board   |
| 2 Batten        | 5 Rafter         |
| 3 Roof Underlay | 6 Dry Fix Valley |

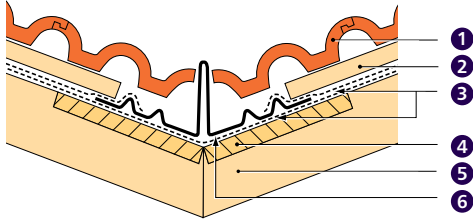

**TILE VALLEY TROUGHS**  
HDL 401 & 402, HDL 361 & 362, HDL RP3 & RP4

- |                 |                  |                |
|-----------------|------------------|----------------|
| 1 Tiles         | 4 Counter Batten | 7 Valley Board |
| 2 Batten        | 5 Mortar         | 8 Rafter       |
| 3 Roof Underlay | 6 Valley Trough  |                |

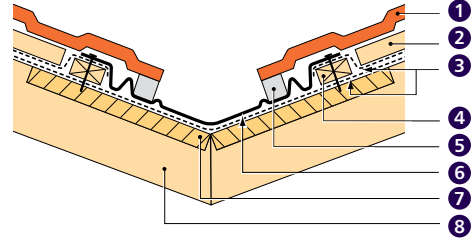

**DRY FIX VALLEY FOR SLATES**  
HDL DVS/1 & 2

- |                 |                  |
|-----------------|------------------|
| 1 Slates        | 4 Rafter         |
| 2 Batten        | 5 Valley Board   |
| 3 Roof Underlay | 6 Dry Fix Valley |

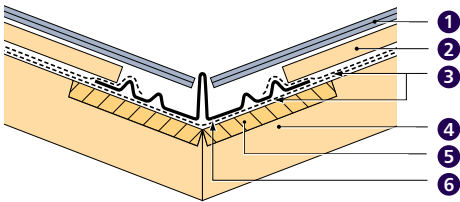

**SLATE VALLEY TROUGHS**  
HDL SVTU & SVT

- |                 |                  |                 |
|-----------------|------------------|-----------------|
| 1 Slates        | 4 Counter Batten | 7 Valley Trough |
| 2 Batten        | 5 Valley Board   |                 |
| 3 Roof Underlay | 6 Rafter         |                 |

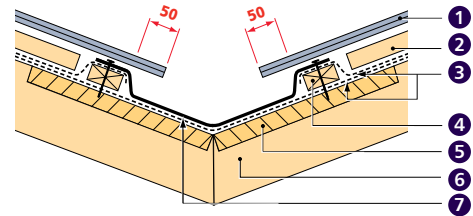

**DRY FIX VALLEY FOR PLAIN / LOW PROFILE TILES**  
HDL DVLPT/1 & 2

- |                 |                  |
|-----------------|------------------|
| 1 Plain Tiles   | 4 Valley Board   |
| 2 Batten        | 5 Rafter         |
| 3 Roof Underlay | 6 Dry Fix Valley |

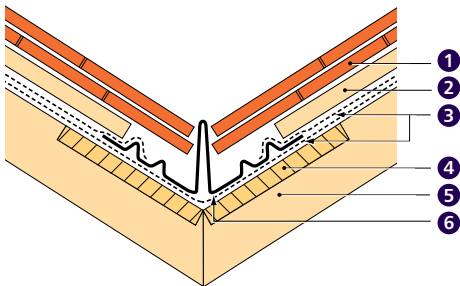

**SCOTTISH SLATE VALLEY TROUGH**  
HDL SSVT

- |                 |                 |                 |
|-----------------|-----------------|-----------------|
| 1 Slates        | 3 Sarking Board | 5 Valley Trough |
| 2 Roof Underlay | 4 Rafter        |                 |

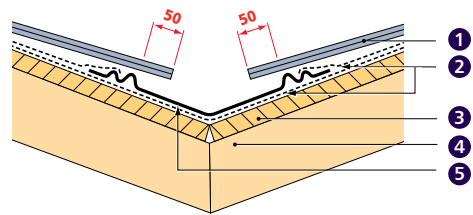

**TYPICAL WARM ROOF INSTALLATION**

- |                  |                 |                  |
|------------------|-----------------|------------------|
| 1 Tiles          | 4 Roof Underlay | 7 Dry Fix Valley |
| 2 Tile Batten    | 5 Valley Board  |                  |
| 3 Counter Batten | 6 Insulation    |                  |

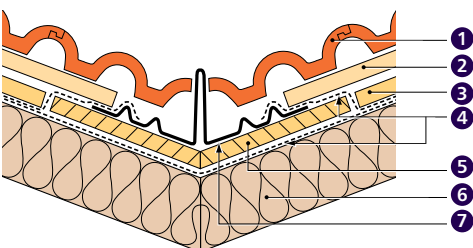

**TYPICAL WARM ROOF INSTALLATION**

- |                  |                  |                 |
|------------------|------------------|-----------------|
| 1 Tiles          | 4 Roof Underlay  | 7 Mortar        |
| 2 Tiling Batten  | 5 Counter Batten | 8 Valley Trough |
| 3 Counter Batten | 6 Valley Board   | 9 Insulation    |

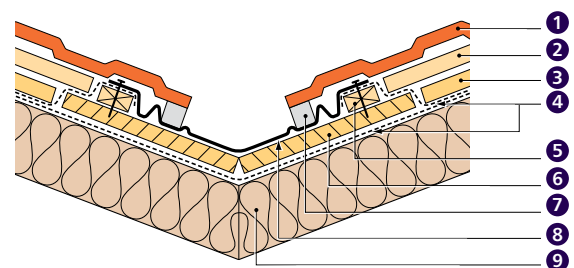



**DRY FIX BONDING GUTTER®**  
**HDL DBG1 & HDL DBG2**

**Dry Fix solution for a mortar-free roof**

**USE:** Creating a successful weather tight joint between dissimilar roof coverings, e.g. slate to tile, or different profile concrete tiles on terraced or semi-detached housing.

Supplied in packs of 5 units.

**HDL DBG1** is 210mm wide and manufactured to a length of 3m with a central upstand height of 70mm to suit slates, flat interlocking tiles and plain tiles.

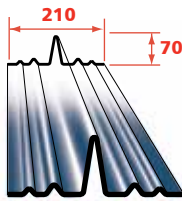

**HDL DBG2** is 210mm wide and manufactured to a length of 3m with a central upstand height of 100mm to suit profiled tiles on one or both sides and also typical Scottish practice where there may be tiling battens on one side only.

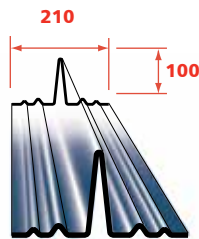

**TYPICAL STANDARD INSTALLATION**  
**HDL DBG**

- |                   |                 |              |
|-------------------|-----------------|--------------|
| 1 Tiles           | 4 Batten        | 6 Rafter     |
| 2 Bonding Gutter® | 5 Roof Underlay | 7 Party Wall |
| 3 Slates          |                 |              |

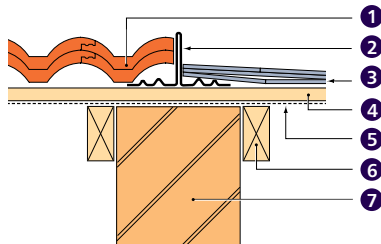

**TYPICAL SCOTTISH INSTALLATION**  
**HDL DBG**

- |                   |                 |                  |
|-------------------|-----------------|------------------|
| 1 Tiles           | 4 Batten        | 7 Party Wall     |
| 2 Bonding Gutter® | 5 Roof Underlay | 8 Counter Batten |
| 3 Slates          | 6 Rafter        | 9 Sarking Board  |

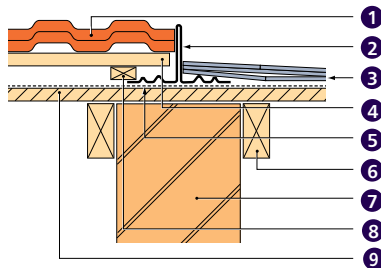

**TYPICAL FIRE BREAK INSTALLATION**  
**HDL DBG**

- |                   |                 |                   |
|-------------------|-----------------|-------------------|
| 1 Tiles           | 5 Roof Underlay | 8 Counter Batten  |
| 2 Bonding Gutter® | 6 Rafter        | 9 Sarking Board   |
| 3 Slates          | 7 Party Wall    | 10 Mortar Barrier |
| 4 Batten          |                 |                   |

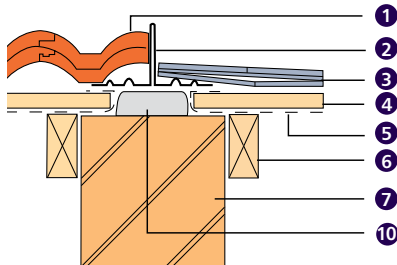

**BONDING GUTTER®**  
**HDL BG**

**Traditional solution for mortar bedding**

**USE:** To join dissimilar roof coverings, e.g. slate to tile, or different profile concrete tiles on terraced or semi-detached housing.

Supplied in packs of 10 units.  
W225mm x L3000mm

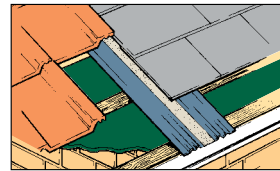
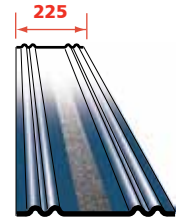

**TYPICAL STANDARD INSTALLATION**  
**HDL BG**

- |                   |                 |              |
|-------------------|-----------------|--------------|
| 1 Tiles           | 4 Slates        | 7 Rafter     |
| 2 Mortar Bedding  | 5 Batten        | 8 Party Wall |
| 3 Bonding Gutter® | 6 Roof Underlay |              |

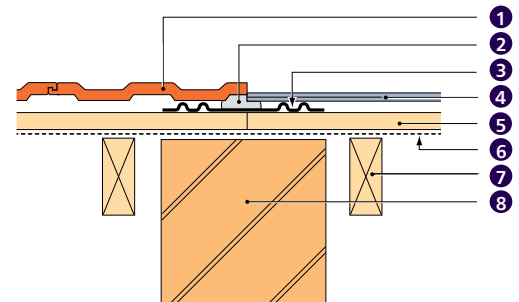

**TYPICAL FIRE BREAK INSTALLATION**  
**HDL BG**

- |                   |                 |                  |
|-------------------|-----------------|------------------|
| 1 Tiles           | 4 Slates        | 7 Rafter         |
| 2 Mortar Bed      | 5 Batten        | 8 Party Wall     |
| 3 Bonding Gutter® | 6 Roof Underlay | 9 Mortar Barrier |

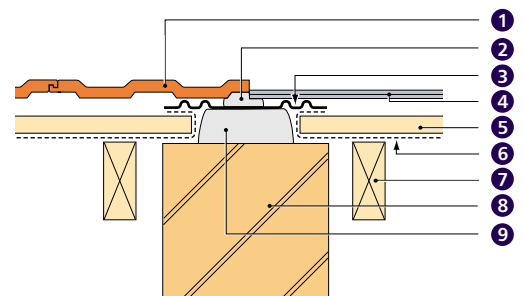

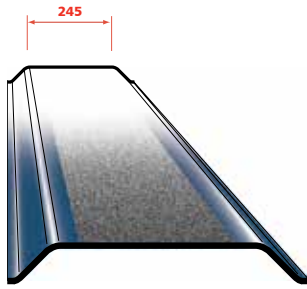

**DAMP PROOF COURSE  
HDL DPC**

A damp proof course specially developed for sloping parapet wall applications incorporating a wide mortar bonding strip.

Supplied in packs of 10 units.

**SIZE:** W310mm x L2440mm

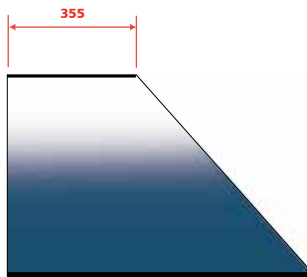
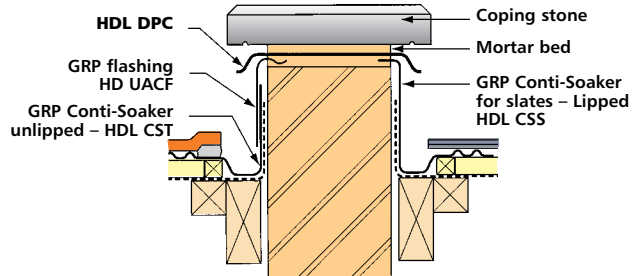

**CONTINUOUS EAVES COURSE  
HDL CECS**

Replaces the need to cut slates to form the first support eaves course.

Supplied in packs of 10 units.

**SIZE:** W355mm x L3000mm

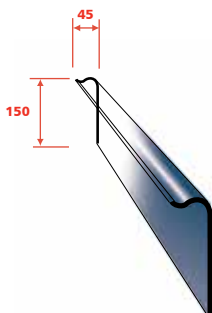
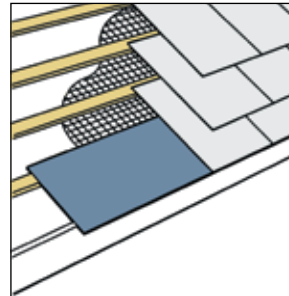

**UNIVERSAL ABUTMENT COVER FLASHING  
HD UACF**

A continuous GRP cover flashing in standard lead grey colour as an attractive and cost effective alternative to lead for all roof abutments. Easily trimmed on site to suit the application.

**SIZE:** H150 x W45 x L3000mm



Conti-Soaker™ Continuous Soakers

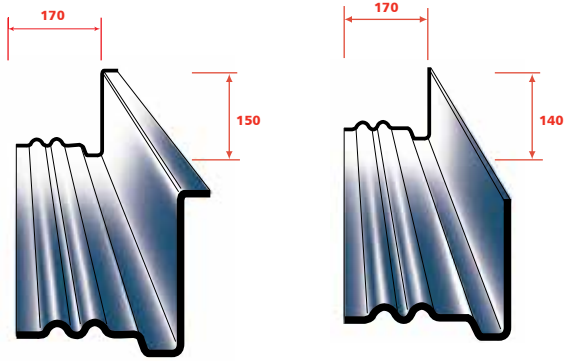

**CONTI-SOAKER™ FOR SLATE**  
**HDL CSS**

Available in Lipped and Unlipped versions for slate roofs, they can be fitted in approximately half the time it takes to install lead.

Supplied in packs of 10 units.

**SIZE:**  
**Lipped**  
H150 x W170 x L3000mm  
**Unlipped**  
H140 x W170 x L3000mm

Also available for Scottish slate practice:

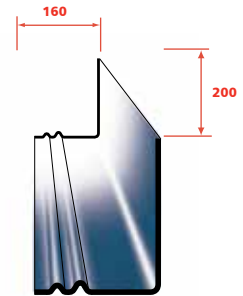

**HDL SCSS Conti-Soaker™.**

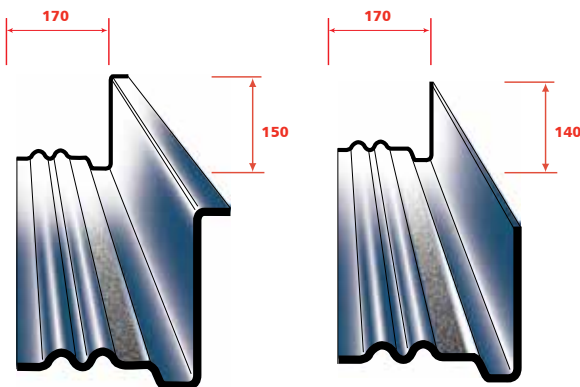

**CONTI-SOAKER™ FOR TILES**  
**HDL CST**

Continuous Soaker for tiles with mortar bonding strip.

Available in Lipped and Unlipped versions for tile roofs, they can be fitted in approximately half the time it takes to install lead.

Supplied in packs of 10 units.

**SIZE:**  
**Lipped**  
H150 x W170 x L3000mm  
**Unlipped**  
H140 x W170 x L3000mm

**TYPICAL INSTALLATION DETAILS**

**LIPPED TILE VERSION**

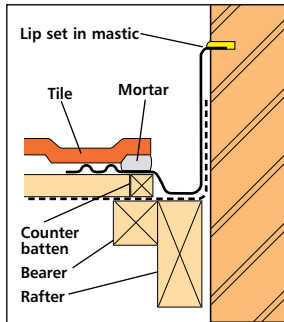

**UNLIPPED TILE VERSION**

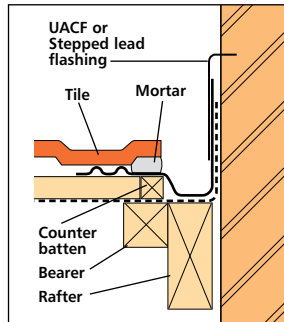

**LIPPED SLATE VERSION**

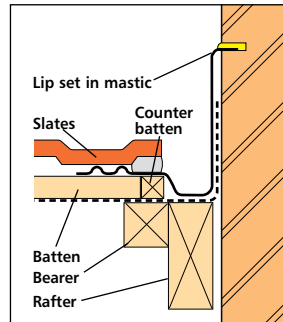

**UNLIPPED SLATE VERSION**

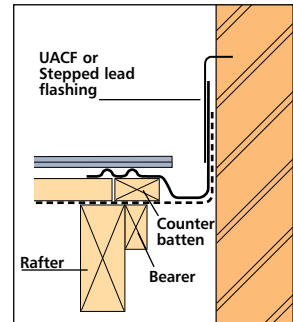

**LIPPED TILE VERSION**

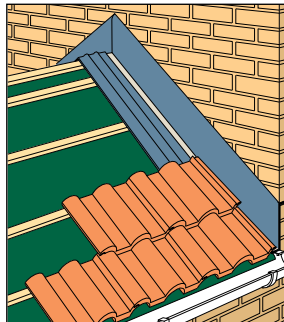

**UNLIPPED SLATE VERSION**

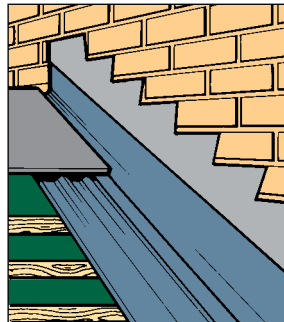

**LIPPED SLATE VERSION**

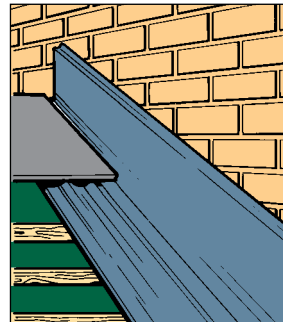

**SCOTTISH VERSION**

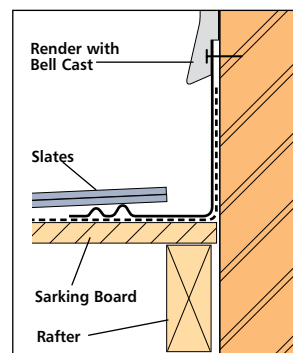

Individual Dry Soakers

All Hambleside Danelaw Individual Dry Soakers are quick and simple to install. They are available for both tile and slate roofs in right and left handed versions. They are made from lightweight, polypropylene chosen for its thermal stability, resistance to UV light, acid rain and cracking under temperature change.

All supplied in packs of 50

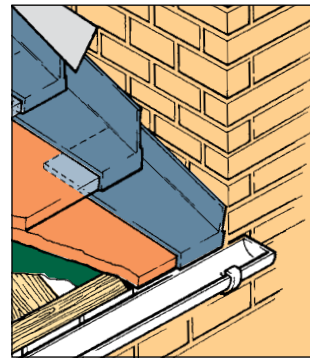

**INTERLOCKING TILES**  
**HD MDS**

For interlocking flat concrete tiles – suitable for use with Marley Modern, Redland Stonewold and equivalent tile types.

**HD MDS/L** - Left handed  
**HD MDS/R** - Right handed (illustrated)

**SIZE:** H75 x W185 x L430mm

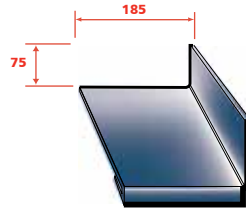

**INTERLOCKING DUO TILES**  
**HD DTS**

Dry soaker for use under the tile and suitable for use with Forticrete Gemini/Minislate, Redland Duo Plain and Marley Ashmore type tiles.

**HD DTS/L** - Left Handed (illustrated)  
**HD DTS/R** - Right Handed

**SIZE:** H105 x W145 x L240mm.

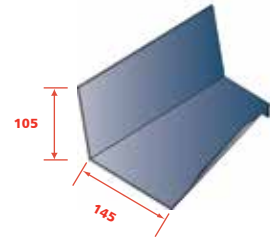

**INTERLOCKING TILES**  
**HD RRS**

Suitable for use with Redland Richmond type tiles except Redland 10 type tiles.

**HD RRS/L** - Left handed  
**HD RRS/R** - Right handed (illustrated)

**SIZE:** H75 x W180 x L430mm

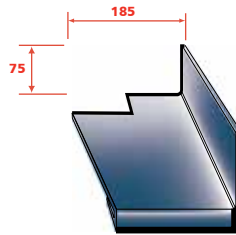

**INTERLOCKING SLATES**  
**HD RCS**

Suitable for use with Redland Cambrian and Marley Melbourne slate.

**HD RCS/L** - Left handed (illustrated)  
**HD RCS/R** - Right handed

**SIZE:** H105 x W155 x L280mm

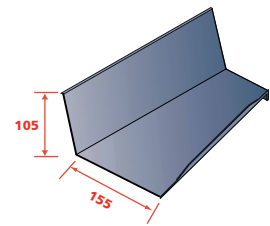

**INTERLOCKING TILES**  
**HD SRRS**

Suitable for use with Marley Edgemere type tiles.

**HD SRRS/L** - Left handed  
**HD SRRS/R** - Right handed (illustrated)

**SIZE:** H75 x W180 x L430mm

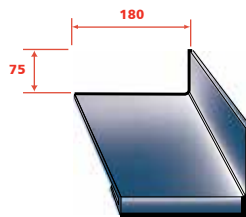

**PLAIN TILES**  
**HD PCS**

Dry soaker suitable for plain clay and concrete tiles.

**HD PCS/L** - Left handed  
**HD PCS/R** - Right handed (illustrated)

**SIZE:** H75 x W100 x L165mm

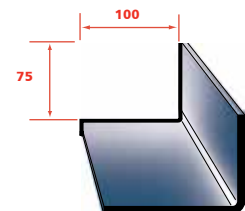

**INTERLOCKING TILES**  
**HD RTS**

Suitable for use with Redland 10 and Russell Galloway type tiles.

**HD RTS/L** - Left handed  
**HD RTS/R** - Right handed (illustrated)

**SIZE:** H75 x W175 x L410mm

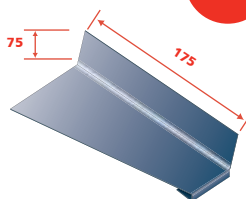

**SLATES**  
**HD SS500 & HD SS600**

**SS500**  
Slate soaker for 500mm x 300mm slates.

**SIZE:** H85 x W100 x L250mm

**SS600**  
Slate soaker for 600mm x 300mm slates.

**SIZE:** H85 x W100 x L380mm

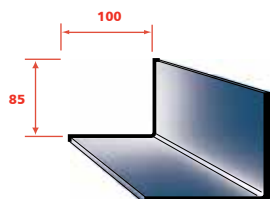



## Dry Verges

Continuous Dry Verges have been developed for use with both natural and fibre cement slates giving the advantages of all weather fixing and permanent wind protection; a product which is simple to install without complicated interlocking methods. Scotverges have been developed for typical Scottish slating practice

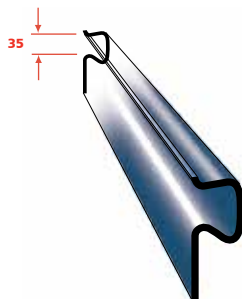
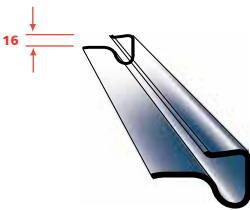
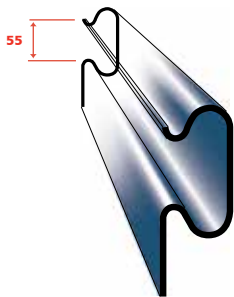
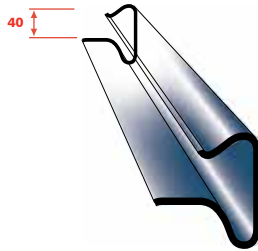

### CONTINUOUS DRY VERGE HDL DV6

For slate roof under batten fixing. Counterbattens fitted between slate battens are recommended to provide closure to the batten cavity when using HDL DV6 & HDL DV8.

Supplied in packs of 10 units.

**GAP:** 40mm  
**LENGTH:** 3000mm

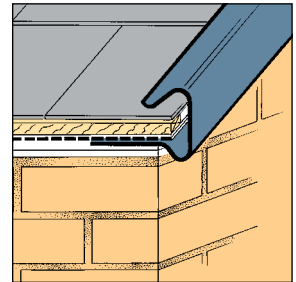

### CONTINUOUS DRY VERGE HDL DV8

For slate and plain tiles – face fixing.

Supplied in packs of 10 units.

**GAP:** 55mm  
**LENGTH:** 3000mm

Standard architrave mouldings can be fitted to the barge board to conceal Dry Verge fixings and enhance finished appearance.

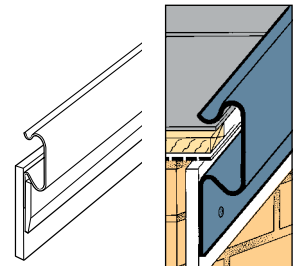

### CONTINUOUS SCOTVERGE HDL DV7



For slate roof – sark board or over batten fixing.

Supplied in packs of 10 units.

**GAP:** 16mm  
**LENGTH:** 3000mm

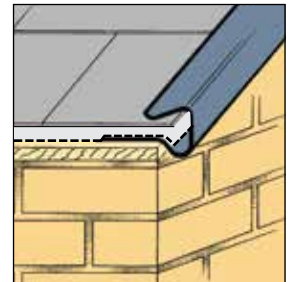

### CONTINUOUS SCOTVERGE HDL DV9



For slate roof – face fixing for sark board detail.

Supplied in packs of 10 units.

**GAP:** 35mm  
**LENGTH:** 3000mm

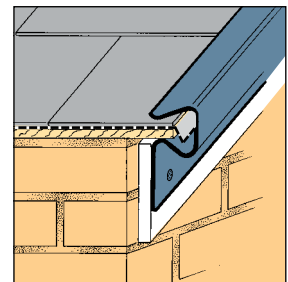

## Dry Verge Joint Details

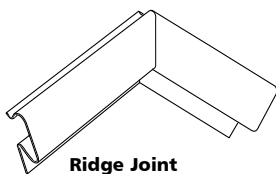

**Ridge Joint**

**Ridges** The Dry Verges are cut with a vertical mitre and butt jointed. A lead saddle may be fitted over the joint if required. The ridge tile should be trimmed if necessary to suit.

**Verge Joints**

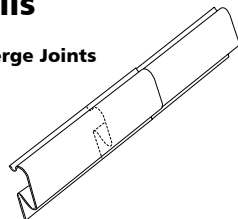

**Verge Joints** Where joints in the Dry Verge are required along the edge of the roof, they should be overlapped with the lower section fitted over/around the upper section.

**Sprocket Joint  
Fig. 1**

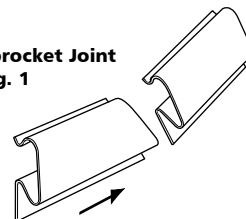

**Sprockets** Slight or gentle sprockets can easily be accommodated by cutting the lower section to a slight rake and fitting over the upper or main Dry Verge section.

**Sprocket Joint  
Fig 2**

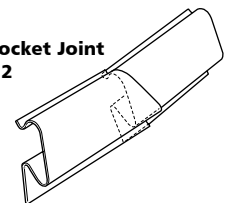

**NOTE:** These jointing methods are suitable for all of the Dry Verge profiles.

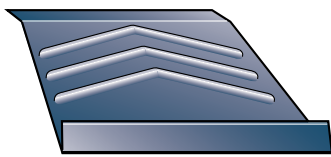
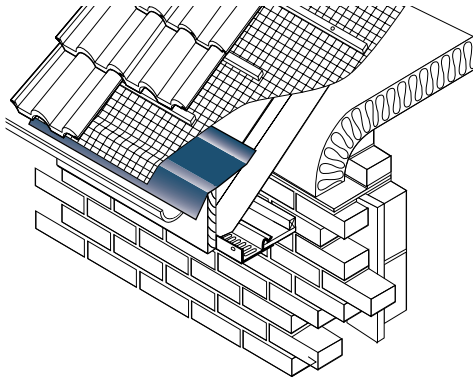
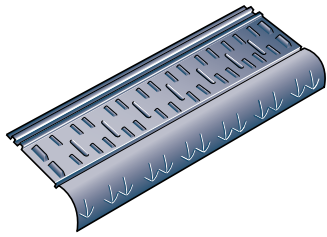

**UNDERLAY SUPPORT TRAY  
HD 3000**

**USE:** Provides full support and eaves protection for roofing underlay at eaves level. Combines to provide drip into guttering.

Fixed with HD 12000M or HD 12000U or directly to the top of the fascia board.

**BENEFITS:** Clips together for universal rafter spacing. Hinged at fascia to prevent panel distortion on low pitches.

**COVERAGE:** 600mm per panel.  
**MATERIAL:** Black PVC.

**RIGID UNDERLAY SUPPORT TRAY  
HD RFST**

**USE:** Ideally suitable for eaves refurbishment details, this rigid pvc unit provides an immediate and cost effective solution to situations where damage to the underlay has occurred.

**USE:** The Underlay Support Tray can be used in conjunction with either traditional soffit strip ventilator configurations (HD 8000 and HD 8250) or with over fascia ventilators (HD 12000M or the HD 12000U universal).

**NOTE:** The Rigid Underlay Support Tray should be nailed to the top of the fascia board.

**LENGTH:** 1500mm  
**MATERIAL:** Black PVC.

**MOISTURE DIVERSION PLATE  
HD IL/DP**

**USE:** An optional extra, the diversion plate provides additional security, if required, against debris and moisture penetration when fitted with either flush fitting slate or tile ventilators.

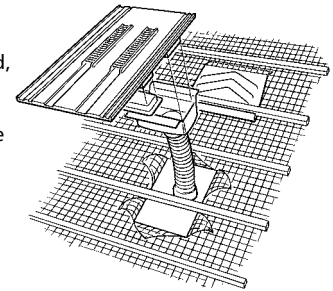

**MATERIAL:** Black PVC.

**LOFT ACCESS TRAP DOORS  
HD TRAPPU & HD TRAPDD**

**USE:** Provides straightforward access through ceilings into loft spaces.

**MATERIAL:** White injection moulded polypropylene with integral insulation.

**ADVANTAGES:** Easy to install, maintenance free, with no need to paint. Loft access door panel offering an integral draft/vapour seal. Push up version is fitted with two catches to provide secure closing and prevent uplift. The hinged version is suitable for use with a telescopic loft ladder.

**SIZES:** All models meet or exceed the NHBC minimum opening size of 520mm in any direction and suit 600mm joist centres. They can be used with other joist centres by cutting a joist and trimming the opening in an approved manner.

**ALSO AVAILABLE:**

0.35W/m<sup>2</sup>K rated Drop Down

**HD TRAP DD 35**

0.35W/m<sup>2</sup>K rated Push Up

**HD TRAP PU 35**

**NOTE:** For lockable loft access doors please contact our sales office.

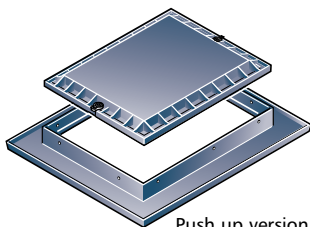

Push up version  
**HD TRAPPU**

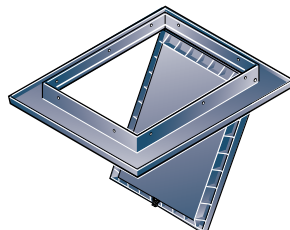

Drop down version.  
**HD TRAPDD**

Steel loft access door, fire rated to Class 0.

**HD TRAPDDF**

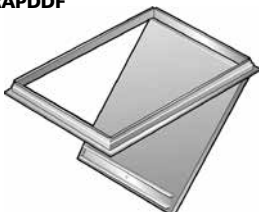

Thermal Performance Building Regulations Approved Document C 2004 Edition requires that in order to resist surface condensation and mould growth, a roof should be designed and constructed so that the thermal transmittance does not exceed 0.35W/m<sup>2</sup>K at any point.

# Hambleside Danelaw Building Products

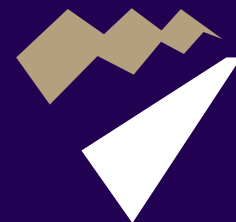

## The Group and the Environment

Hambleside Danelaw has developed a comprehensive environmental policy, embracing the key issues of greenhouse gas emissions, sustainability and recycling of product at end of life. Full information on the environmental policies of Hambleside Danelaw, including its Corporate Social Responsibility statement, is available from our website.

Hambleside Danelaw is committed to the environment.  
This document is printed using processes that are:

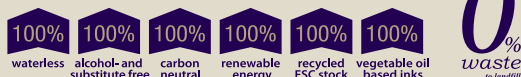

printed by SEACOURT.net, counted amongst the top environmental printers in the world



**Hambleside Danelaw Limited**  
**Long March**  
**Daventry**  
**Northamptonshire**  
**NN11 4NR**

**Telephone**  
**01327 701900**

**Fax**  
**01327 701909**

**E-mail**  
**sales@hambleside-danelaw.co.uk**

**Web**  
**www.hambleside-danelaw.co.uk**

The Company has a continuing product development programme. News relating to these products, or technical developments, is issued regularly in the form of Information and Data Sheets.

Communication with our customers is welcomed on all subjects relating to the performance of products, or on their use on-site. In accordance with our policy for continuous improvement we reserve the right, should the need arise, to amend product specifications without prior notice.

Terms and Conditions of Sale are available upon request.

The Company reserves the right to implement a 25% restocking charge for returned goods.

All images are for illustration purposes only and Hambleside Danelaw reserve the right to amend specifications without prior notice.