

HALFEN HLB LOOP BOX

TECHNICAL PRODUCT INFORMATION



HALFEN HLB LOOP BOX

CONCRETE

HLB 15.1-E

- with RAL Quality Mark RAL-GZ 658/2
- Approval acc. to Eurocode 2



HALFEN HLB LOOP BOX

Introduction

Economical solutions with HALFEN HLB Loop Box



- Sturdy steel case - ensures stability when nailing to the formwork and during concreting
- Solid steel cover - the HLB Loop Box element can be glued to steel formwork
- Pre-punched nail holes for easy fixing to the formwork
- The loops pop up automatically - time saving: no rebending is required
- Flexible wire loops can spring back during setting up - closing a gap can be easily carried out
- Officially approved system - guarantees reliability of the design
- Ideal product dimensions, the HLB Loop Box elements are packed in standard euro-pallet dimensions - advantageous for logistics and storage
- HLB Spacer (foam recess body) used as modules for interspaces - can be simply cut to length using a common cutter or sharp knife and allow flexible and quick assembly

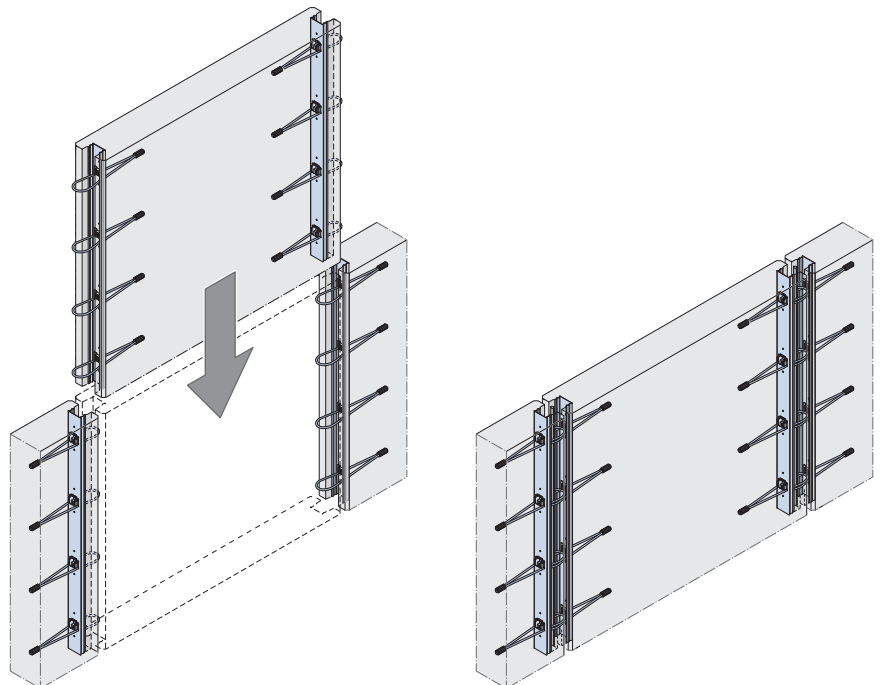

The RAL Quality Mark guarantees compliance with the technical product requirements and the related services regarding:

- Specification, quality management, logistics, competent technical advice, high-quality technical documentation and software, fulfilment of the guaranteed benefits and guaranteeing the neutrality of tender documents.

Biannual monitoring provided by German LLoyd guarantees that the recommended requirements of the Quality Control Association for Anchor and Reinforcement Technology (Gütegemeinschaft Verankerungs und Bewehrungstechnik e.V) are maintained.

HALFEN HLB LOOP BOX

Product overview

HLB Loop Box - The Complete Range

HLB M

Multi Loop Box
→ Pages 4-9
for load bearing
or constructive
junctions

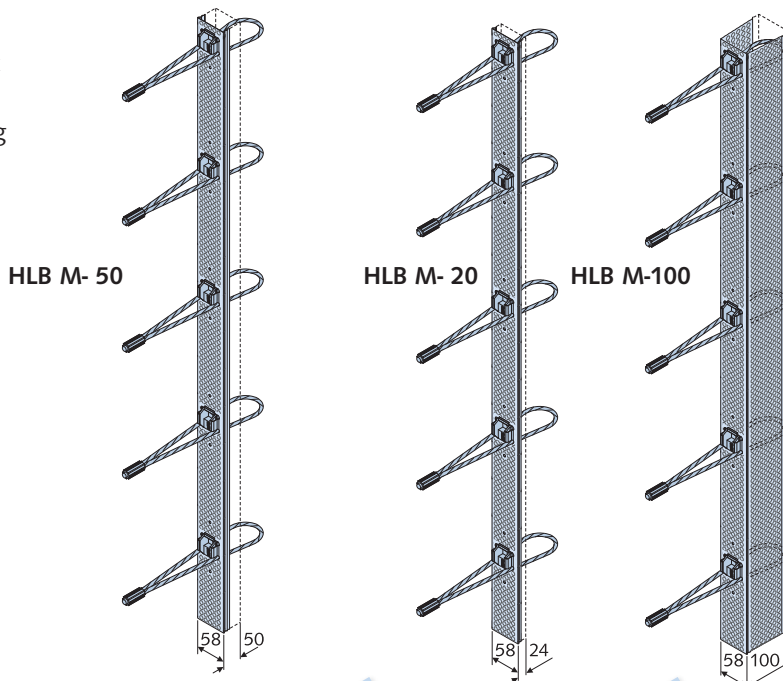

HLB S

Single Loop Box
→ Page 10
for constructive
junctions

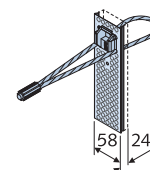

HLB M- 50/250
→ Pages
6-7

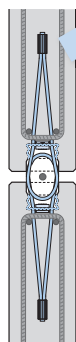

Approved DIBt

HLB M- 20/250 +
HLB M-100/250
→ Pages
8-9

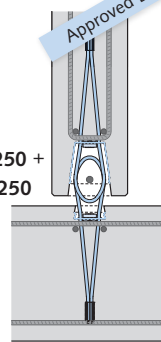

Approved DIBt



HLB Spacer

→ Page 11

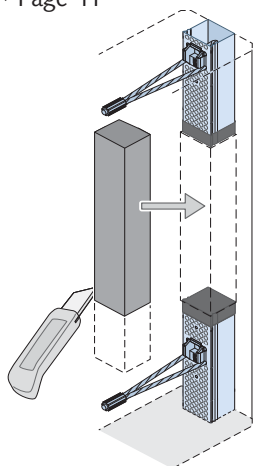

HLB Application

→ Pages 12-15

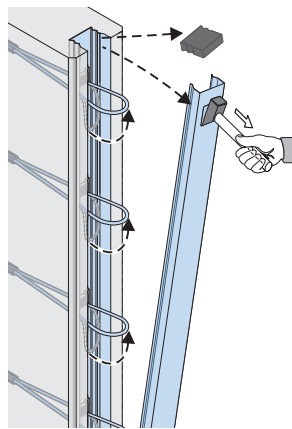
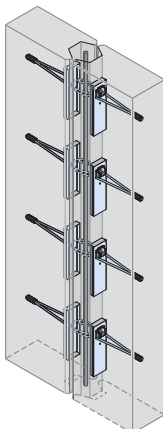

HLB Mix

→ Page 16

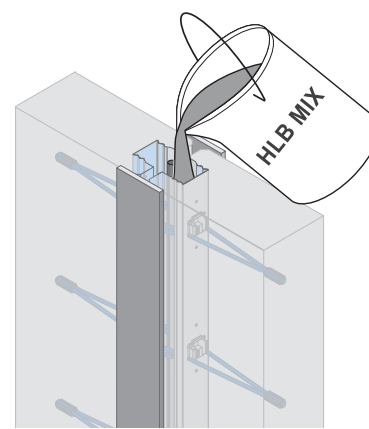

HALFEN HLB LOOP BOX

Product description

HLB M Multi Loop Box

for the junction between precast concrete elements under transverse loads perpendicular and parallel to the joint

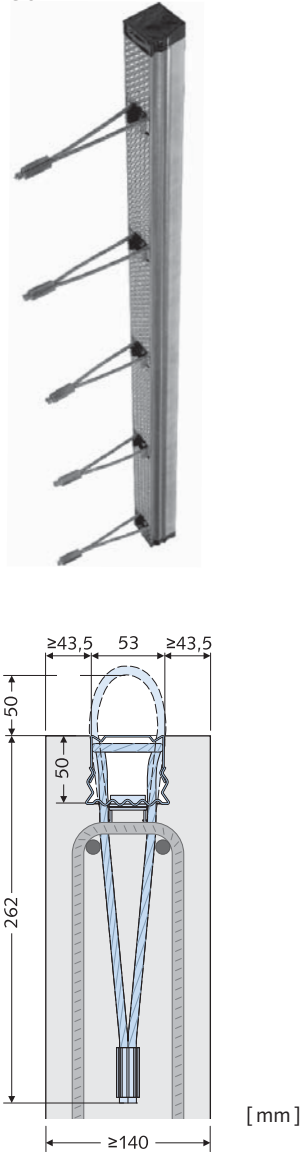
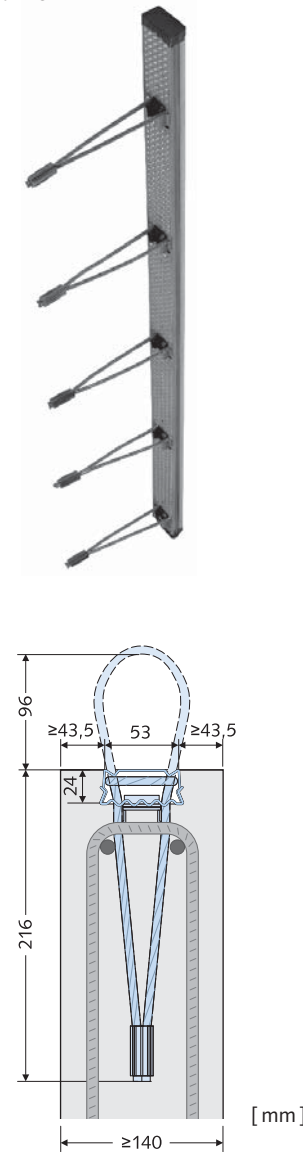
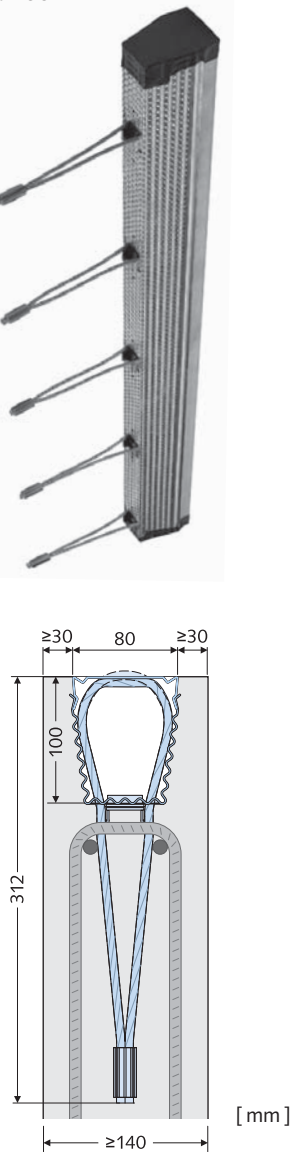
HLB M- 50	HLB M- 20	HLB M-100
		
<p>HLB M- 50/250 officially approved by DIBt: → see Pages 6-7</p>	<p>HLB M- 20/250 in combination with HLB M-100/250 officially approved by DIBt: → see Pages 8-9</p>	

Standard gap width: 20 mm

Installation dimensions → Pages 14-15

Directives for installation → Pages 14-15

Notes for the constructive load bearing behaviour → Pages 12-13

Materials:

Casing: steel, galvanised; profiled back, with pre-punched nail holes; cover with pre-punched opening for removing after striking the formwork

Steel wire loop: high strength, galvanised; steel ferrule

HALFEN HLB LOOP BOX

Product description

HLB M Multi Loop Box

Type selection

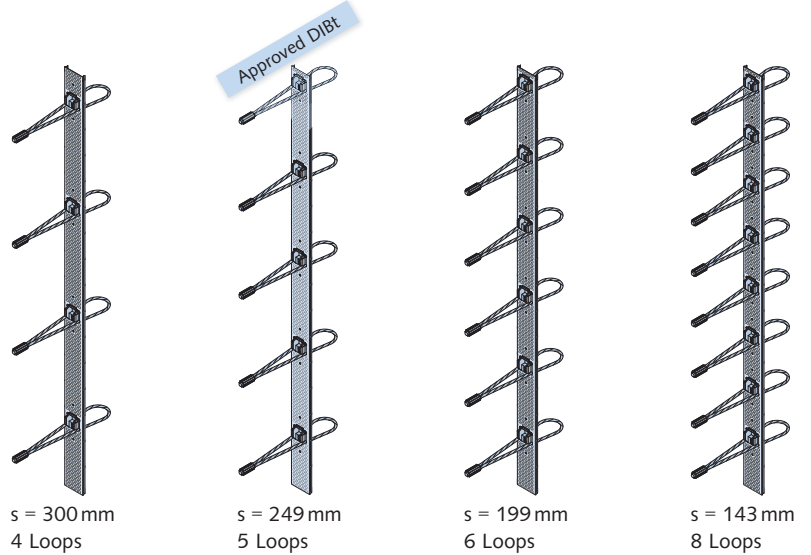
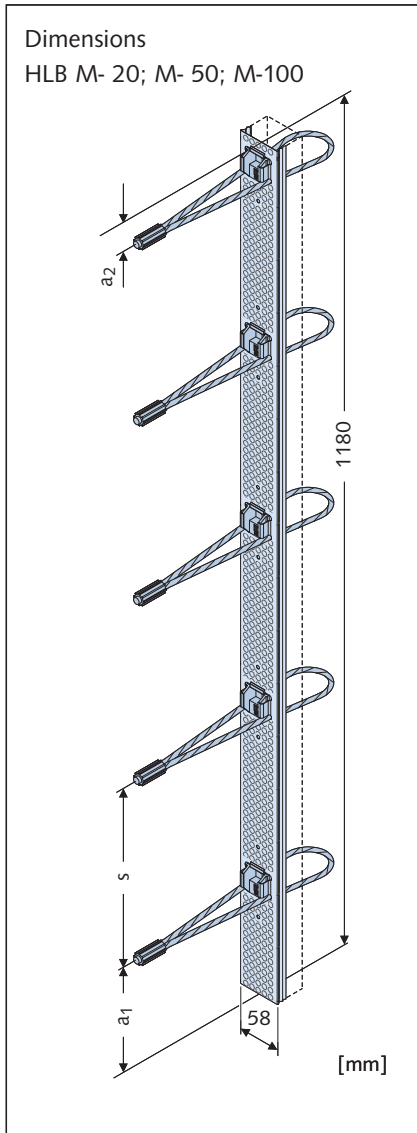

Product range HALFEN HLB M Multi Loop Box

Item name	Article no.	No. of loops	s [mm]	a ₁ [mm]	a ₂ [mm]	Weight [kg]	Packing unit [pieces]
HLB M- 20/300	0058.030-00003	4	300	175	105	1.5	80
HLB M- 20/250	0058.030-00004	5	249	133	51	1.7	80
HLB M- 20/200	0058.030-00005	6	199	133	52	1.8	80
HLB M- 20/150	0058.030-00006	8	143	133	46	2.1	80
HLB M- 50/300	0058.040-00003	4	300	175	105	1.8	60
HLB M- 50/250	0058.040-00004	5	249	133	51	1.9	60
HLB M- 50/200	0058.040-00005	6	199	133	52	2.1	60
HLB M- 50/150	0058.040-00006	8	143	133	46	2.4	60
HLB M-100/300	0058.050-00003	4	300	175	105	2.5	40
HLB M-100/250	0058.050-00004	5	249	133	51	2.6	40
HLB M-100/200	0058.050-00005	6	199	133	52	2.8	40
HLB M-100/150	0058.050-00006	8	143	133	46	3.0	40

Order example for HALFEN Loop Box:

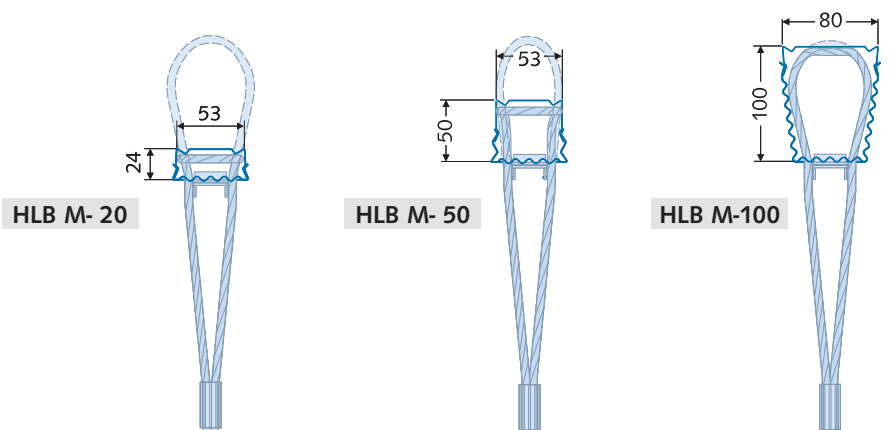
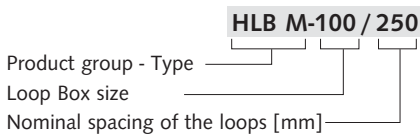

HALFEN HLB LOOP BOX

Product description

HLB M 50 Multi Loop Box

Combination of HLB M- 50/250 on both sides - officially approved, approval DIBt No. Z-21.8-1869

for the junction between precast concrete elements under transverse loads perpendicular and parallel to the joint

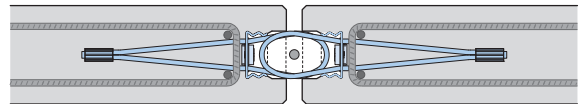
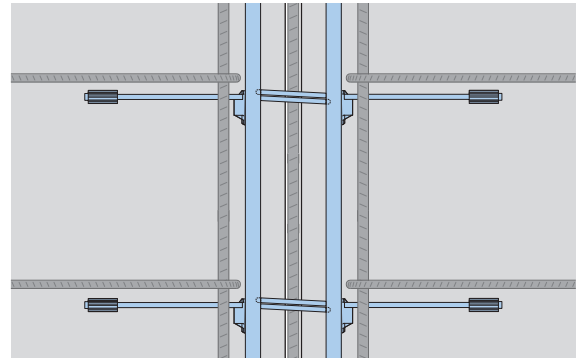
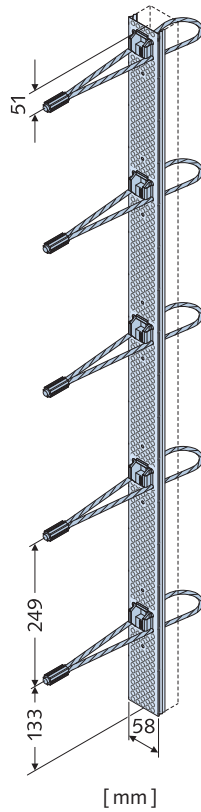

Standard gap width: 20 mm
 Installation dimensions → Page 7
 Directives for installation → Pages 14-15

Application examples of the combination HLB M- 50/250 + HLB M- 50/250:

Butt junction wall to wall

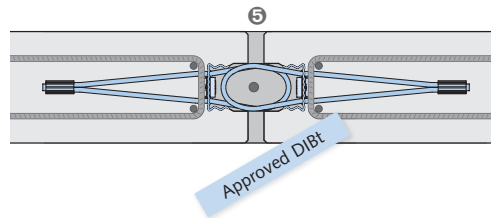

Junction wall to column

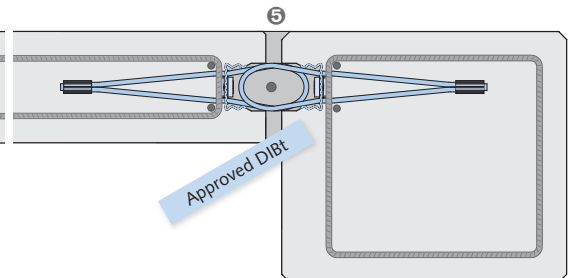

Order example for HALFEN Loop Box:

Product group - Type **HLB M- 50 / 250**
 Loop Box size _____
 Nominal spacing of the loops [mm] _____

Wall corner junction

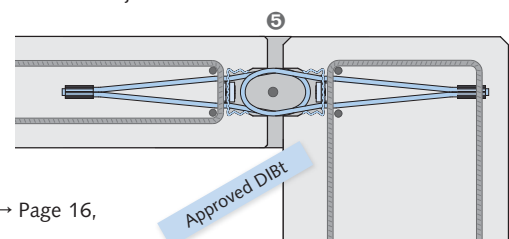

⑤ Joint filling with HLB Mix → Page 16,
 Joint details → Page 15

HALFEN HLB LOOP BOX

Product description, load capacity according to EC 2, application examples

Load capacity for applications according to EC 2

The official approval applies for construction elements under predominantly static loads. If imposed deformations due to e.g. temperature changes or outdoor weathering can not be excluded, the crack width of the junction has to be restricted to $w_k \leq 0.3$ mm. Transverse loads do not lead to an additional crack opening. The product is not designed for regular tension loads. To include the expansion forces arising in the joint, an exterior tensional force has to be taken into consideration according to DAfStb booklet 525, which is at least 1.5 times the shear force to be transferred perpendicularly over the joint. The official approval is to be observed.

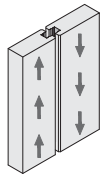

Design value of the transverse load capacity parallel to the joint (plane of the wall) $V_{Rd, \parallel}$ [kN/m]				
Wall thickness [cm]	HLB M- 50/250 + HLB M- 50/250			
	C30/37	C35/45	C40/50	C45/55
≥ 14	45.0 *			

* Moreover, no further limitation of the absorbable shear stresses in the joint of diaphragms according to EC2, chapter 10.9.3 (12) is required.

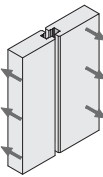

Design value of the transverse load capacity perpendicular to the joint (plane of the wall) $V_{Rd, \perp}$ [kN/m] (Table 'B')				
Wall thickness [cm]	HLB M- 50/250 + HLB M- 50/250			
	C30/37	C35/45	C40/50	C45/55
14	8.8	10.0	10.7	11.4
15	10.2	11.6	12.4	13.3
16	11.7	13.3	14.3	15.2
17	13.2	15.0	16.1	17.2
18	14.8	16.9	18.1	19.3
19	16.4	18.7	20.1	21.4
20	18.1	20.6	22.2	23.6
21	19.9	22.6	24.3	25.9
22	21.6	24.7	26.5	28.2
23	23.5	26.8	28.7	30.6
24	25.4	28.9	31.0	33.0
25	27.3	31.1	33.3	35.5
≥ 26	29.2	33.3	35.7	37.5

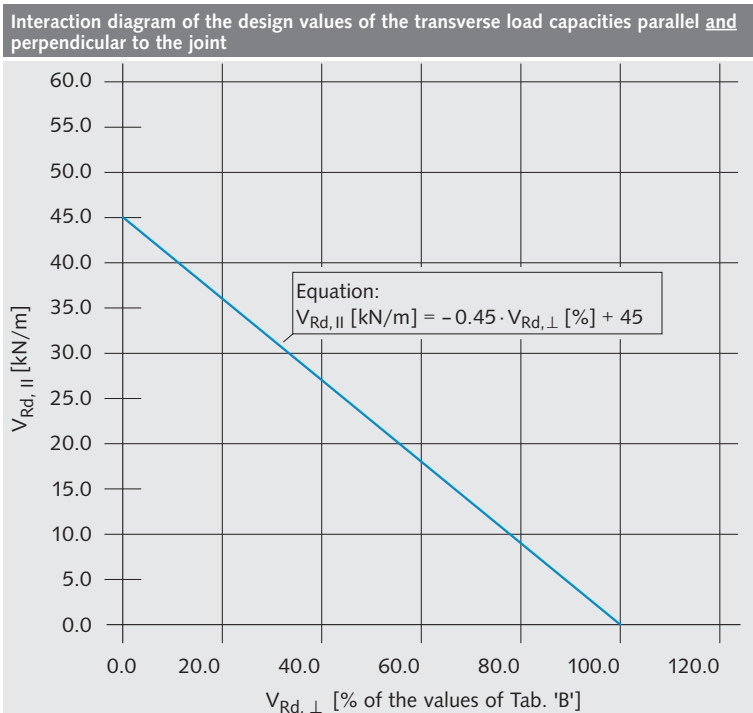
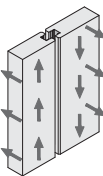

Minimum reinforcement, alignment

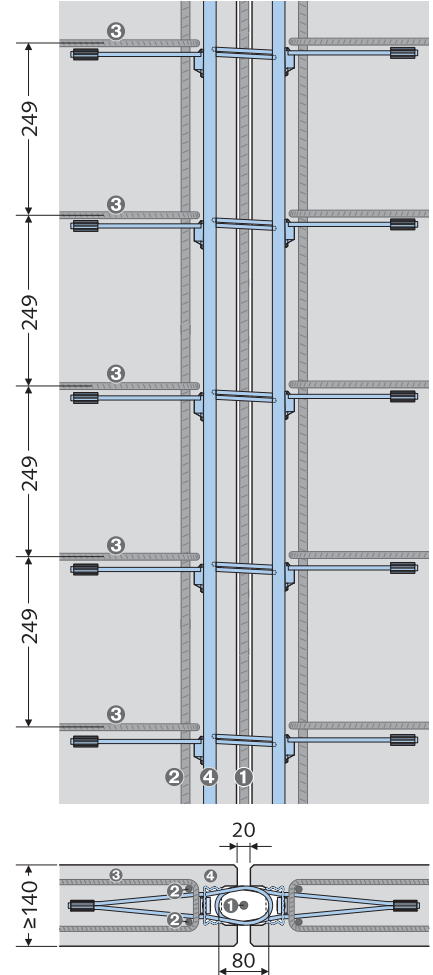

- ① Bar B 500 A, diam. 12 mm
- ② Bar B 500 A, diam. 10 mm
- ③ Stirrup B 500 A, diam. 8 mm, anchoring according to EC2
- ④ HLB M- 50

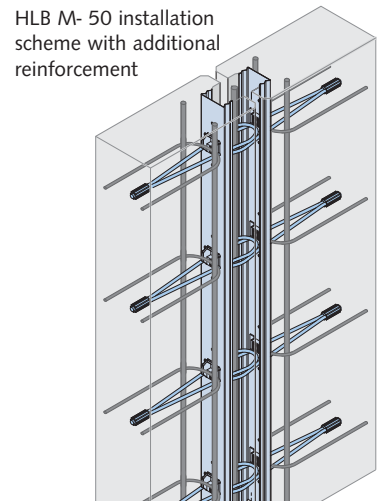

HALFEN HLB LOOP BOX

Product description

HLB M 20 and HLB M 100 Multi Loop Box

Combination of HLB M- 20/250 + HLB M-100/250 - officially approved, approval DIBt No. Z-21.8-1871 for the junction between precast concrete elements under transverse loads perpendicular and parallel to the joint

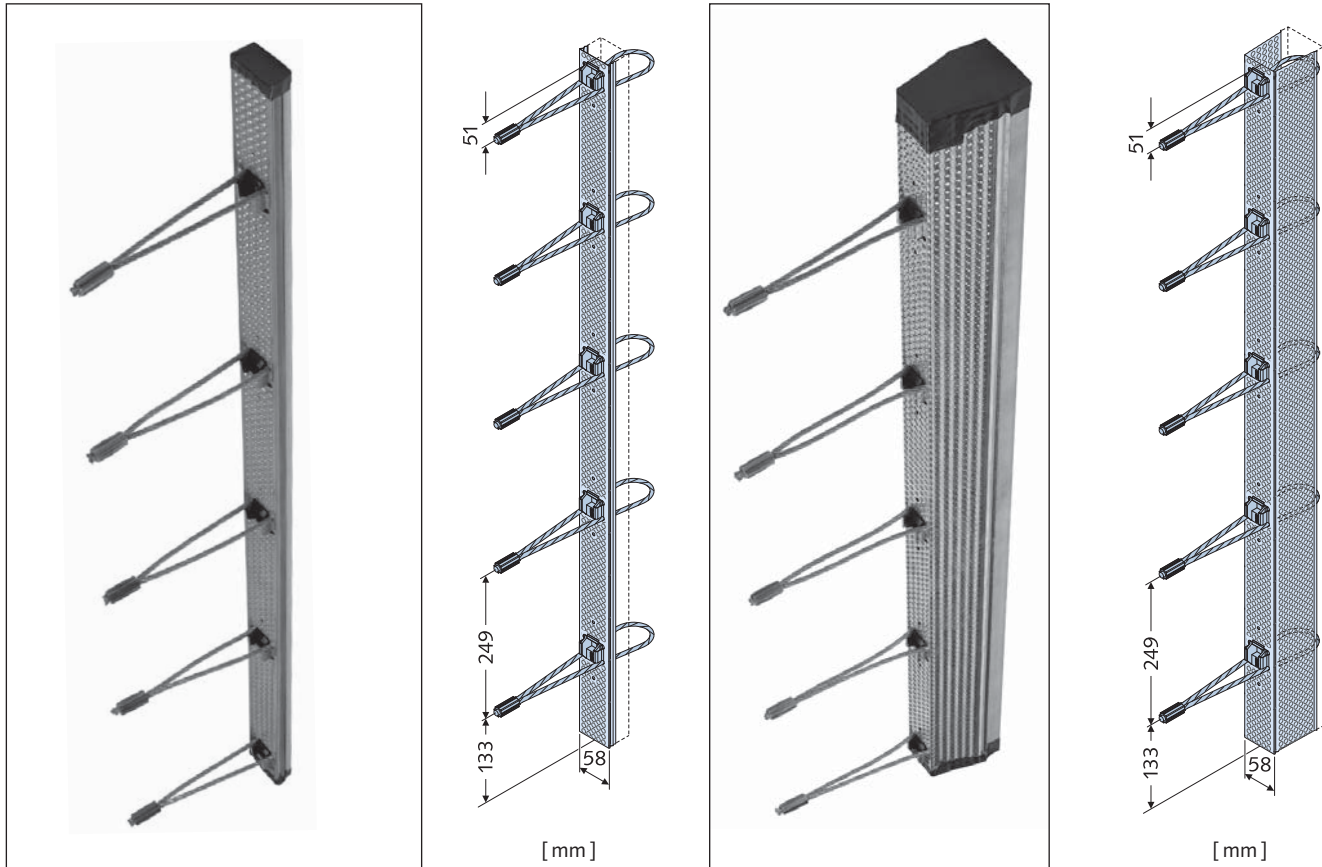

Application examples of the combination HLB M- 20/250 + HLB M-100/250:

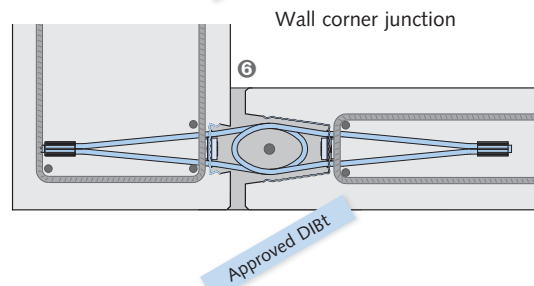
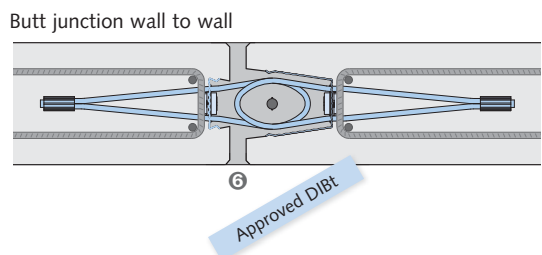
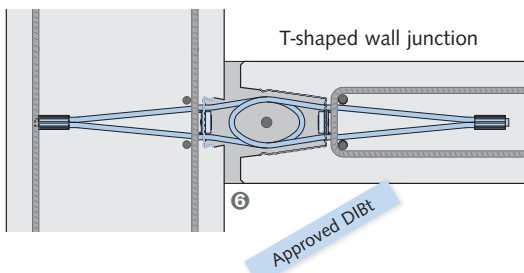

Standard gap width: 20 mm
 Installation dimensions → Page 9
 Directives for installation → Pages 14-15

Order examples for HALFEN Loop Box:

HLB M-100 / 250

HLB M- 20 / 250

Product group - Type _____
 Loop Box size _____
 Nominal spacing of the loops [mm] _____

ⓐ Joint filling with HLB Mix → Page 16,
 Joint details → Page 15

HALFEN HLB LOOP BOX

Product description, load capacity according to EC 2, application examples

Load capacity for applications according to EC 2

The official approval applies for construction elements under predominantly static loads. If imposed deformations due to e.g. temperature changes or outdoor weathering can not be excluded, the crack width of the junction has to be restricted to $w_k \leq 0.3$ mm. Transverse loads do not lead to an additional crack opening. The product is not designed for regular tension loads. To include the expansion forces arising in the joint, an exterior tensional force has to be taken into consideration according to DAfStb booklet 525, which is at least 1.5 times the shear force to be transferred perpendicularly over the joint. The official approval is to be observed.

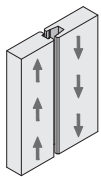

Design value of the transverse load capacity parallel to the joint (plane of the wall) $V_{Rd, \parallel}$ [kN/m]				
Wall thickness [cm]	HLB M- 20/250 + HLB M-100/250			
	C30/37	C35/45	C40/50	C45/55
≥ 14	50.0 *			

* Moreover, no further limitation of the absorbable shear stresses in the joint of diaphragms according to EC2, chapter 10.9.3 (12) is required.

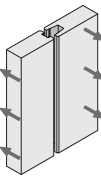

Design value of the transverse load capacity perpendicular to the joint (plane of the wall) $V_{Rd, \perp}$ [kN/m] (Table 'C')				
Wall thickness [cm]	HLB M- 20/250 + HLB M-100/250			
	C30/37	C35/45	C40/50	C45/55
14	8.8	10.0	10.7	11.4
15	10.2	11.6	12.4	13.3
16	11.7	13.3	14.3	15.2
17	13.2	15.0	16.1	17.2
18	14.8	16.9	18.1	19.3
19	16.4	18.7	20.1	21.4
20	18.1	20.6	22.2	23.6
21	19.9	22.6	24.3	25.9
22	21.6	24.7	26.5	28.2
23	23.5	26.8	28.7	30.6
24	25.4	28.9	31.0	33.0
25	27.3	31.1	33.3	35.5
≥ 26	29.2	33.3	35.7	37.5

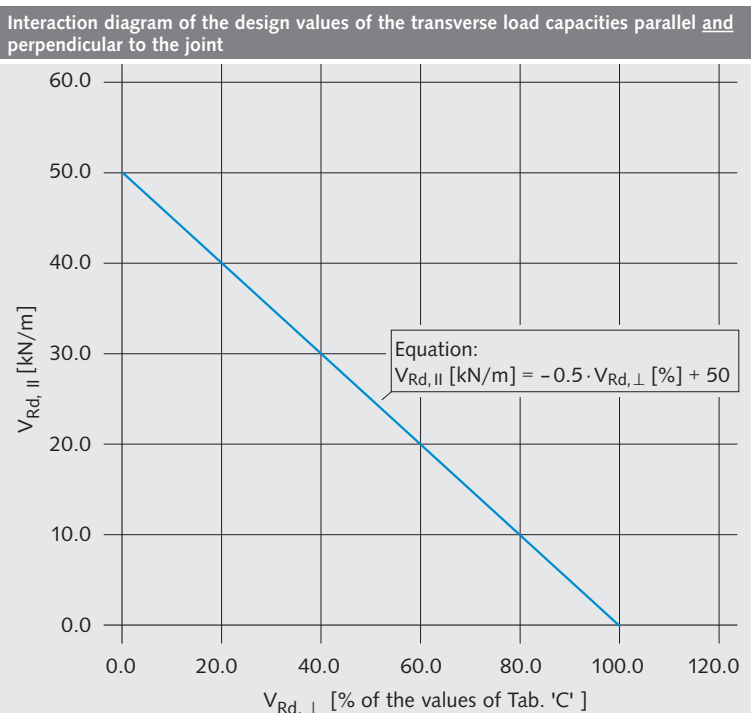
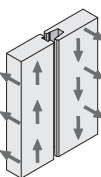

Minimum reinforcement, alignment

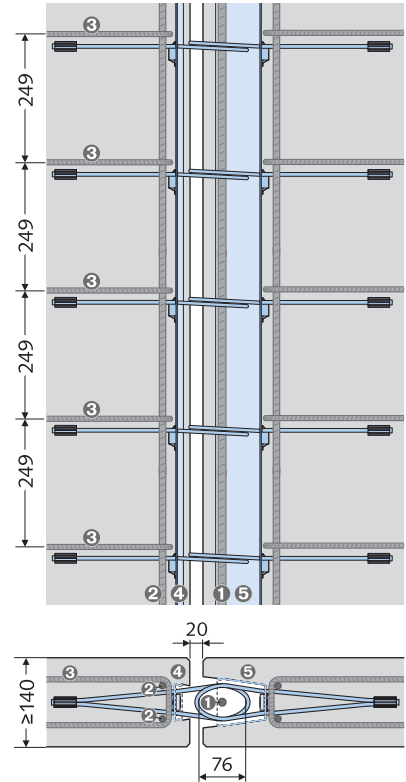

- ① Bar B500 A, diam. 12 mm
- ② Bar B500 A, diam. 10 mm
- ③ Stirrup B500 A, diam. 8 mm, anchoring according to EC2
- ④ HLB M- 20/250
- ⑤ HLB M-100/250

HLB M- 20/250 + HLB M-100/250 installation scheme with additional reinforcement

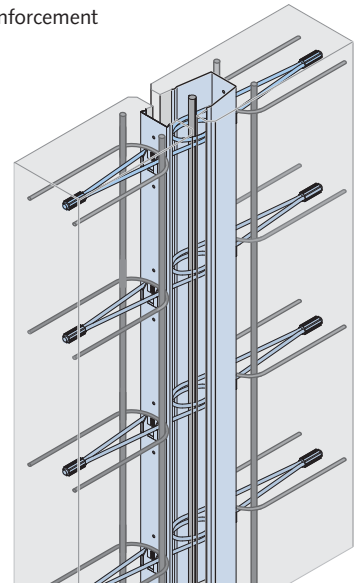

HALFEN HLB LOOP BOX

Product description

HLB S Single Loop Box

for constructive junctions between precast concrete elements

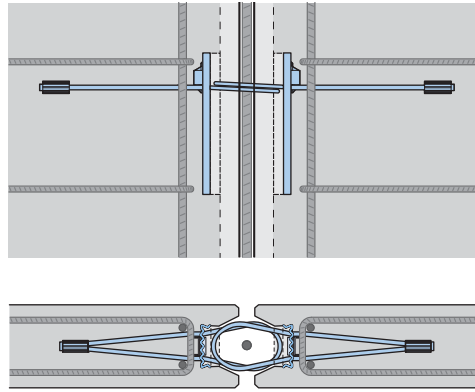
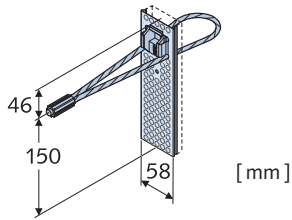

Standard gap width: 20 mm
 Installation dimensions → Pages 14-15
 Directives for installation → Pages 14-15
 Notes for the constructive load bearing behaviour → Pages 12-13

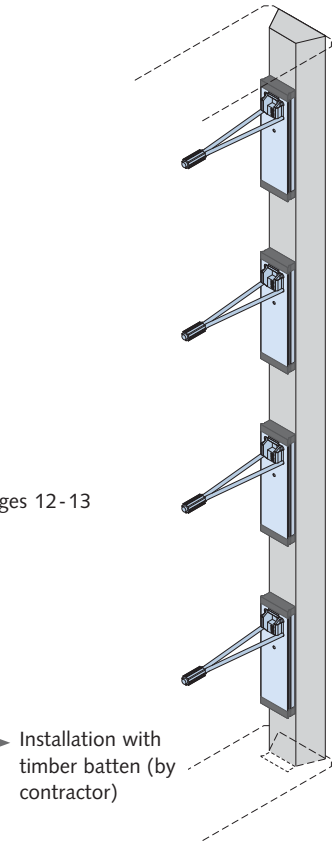
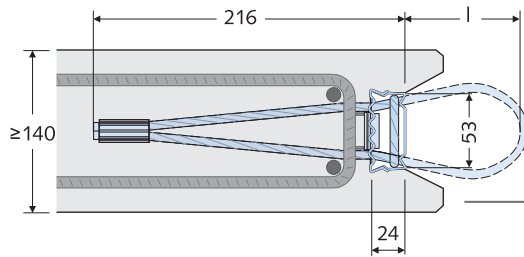

Materials:

Casing: Steel, galvanised; profiled back, with pre-punched nail holes; lid with pre-punched opening for removing after striking the formwork
 Steel wire loop: High strength, galvanised; steel ferrule

Product range HALFEN HLB S Single Loop Box						
Item name	Article no.	No. of loops	Loop length l [mm]	Clip colour	Weight [kg]	Packing unit [pieces]
HLB S- 80	0058.010-00001	1	76	black	0.3	500
HLB S-100	0058.010-00002	1	96	white	0.3	500
HLB S-120	0058.010-00003	1	116	blue	0.3	500

Order example for HALFEN Loop Box:

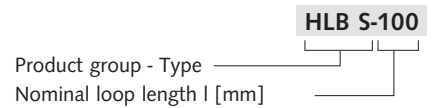

Application examples HLB S:

Butt junction wall to wall

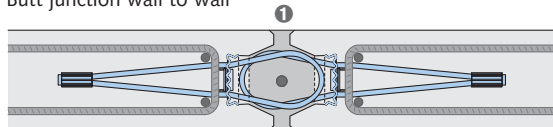

Junction wall to column

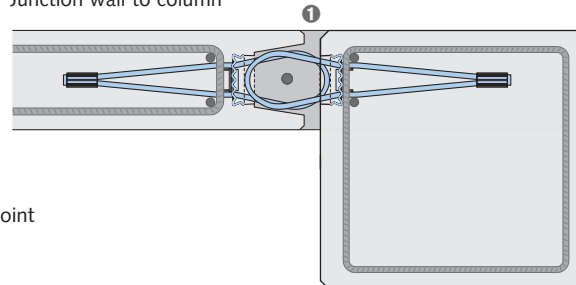

Butt junction wall to wall, with filling channel only on one side of the joint

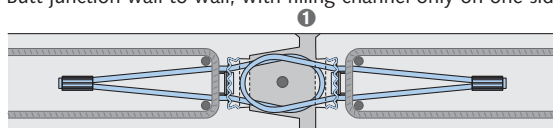

① Joint filling with HLB Mix → see Page 16, Joint details → Page 15

HALFEN HLB LOOP BOX

Application

HLB Spacer for Loop Box

Economical and time saving method for producing a continuous joint filling channel, which is requested, if HALFEN Multi Loop Box elements are applied with interspacing for length adaption.

Material: foam profile strip, dimensionally stable

Application:

- Select the HLB Spacer type suitable to the Loop Box
- Cut to the required length using a common cutter or sharp knife
- Attach the HLB Spacer to the formwork using nails, glue or adhesive tape

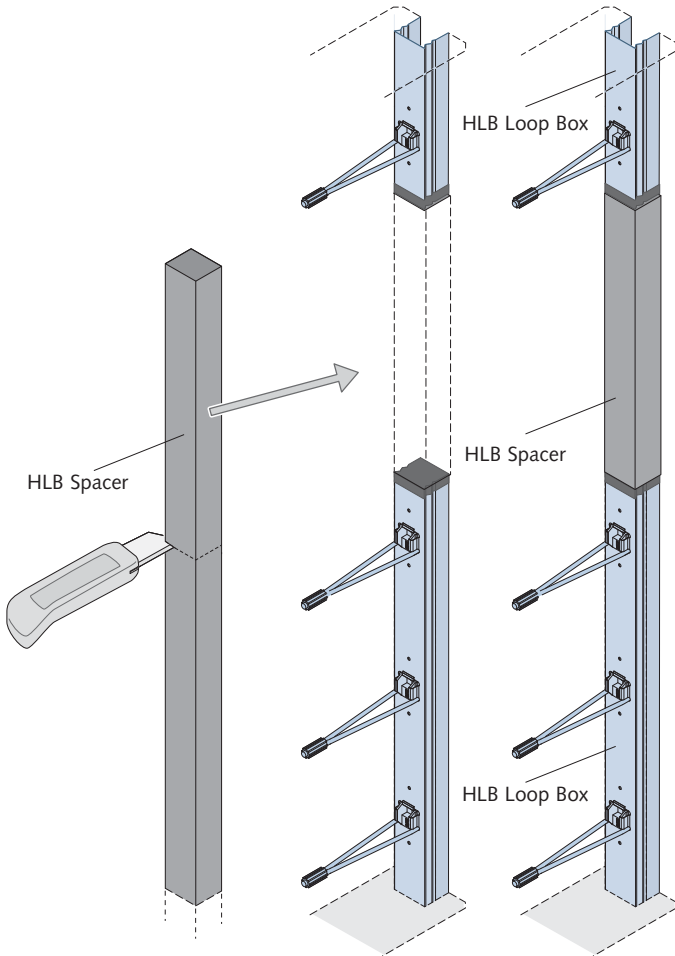

HLB Spacer- 20

HLB Spacer- 50

HLB Spacer-100

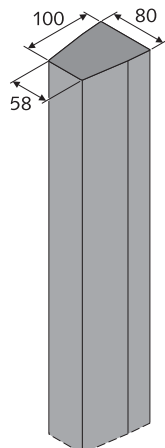
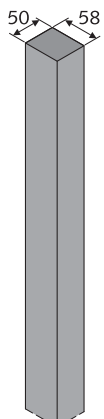
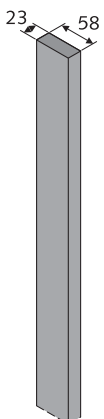

Type range HALFEN HLB Spacer for Loop Box				
Item name	Article no.	fits to Loop Box	Packing unit [pieces]	Length [mm]
HLB Spacer- 20	0058.070-00001	HLB M- 20	80	1000
HLB Spacer- 50	0058.070-00002	HLB M- 50	60	1000
HLB Spacer-100	0058.070-00003	HLB M-100	40	1000

Order example HLB Spacer:

HLB Spacer- 50

Product group - Type _____
fits to Loop Box HLB M size _____

HALFEN HLB LOOP BOX

Information on the constructive load bearing behaviour

Note: for the officially approved product combinations refer to the information given in this brochure (→ Pages 6-9) and in the official approval documents.

The following notes provide a basic understanding of the load bearing behaviour for the **constructive application**. However they are not to be considered as normative proofs.

1. Transfer of tension loads perpendicular to the joint

The transfer of tension loads results from the overlap of the wire loops (fig. 1). In the area of the loops the compression loads are transmitted to the grout fill. A tension load acts vertically to the plane of the loop, which must be taken up by a vertical reinforcement bar, as shown in fig. 2.

Assuming a global safety factor $\gamma = 3.0$ and a minimum breaking load of the cable of $F_{min} = 22.7$ kN the maximum applicable tension load $Z_{max,l}$ is 15.1 kN per wire loop.

$$Z_{max,l} = \frac{F_{min} \cdot 2}{\gamma} = \frac{22.7 \cdot 2}{3.0} = 15.1 \text{ kN}$$

Considering the serviceability limit state we recommend to specify a load not exceeding 10 kN per loop (characteristic value). Experimental tests, which have been carried out with concrete grade C30/37 and a clearance between the HLB S elements of 11 cm in the longitudinal direction of the joint, resulted in a widening of the joint of 0.4 mm at this load.

Fig. 1: Tension loads perpendicular to the joint

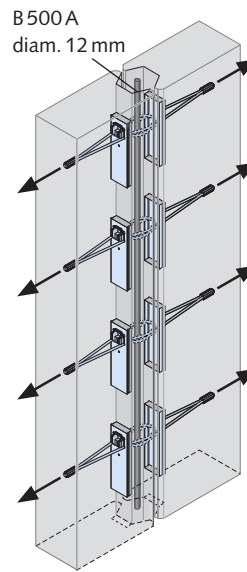
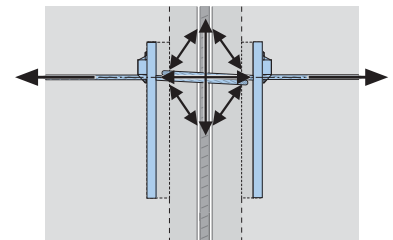

Fig. 2: Model for the tension load vertical to the joint



2. Transfer of shear loads parallel to the joint

Shear loads can act parallel to the joint (fig. 3). A model for the transfer of these shear loads across the joint is shown in fig. 4. Therein the shear load acting in the joint is divided into a tension and a compression strut. The values of the tension and compression loads depend on the angle ϑ .

HALFEN Single Loop Box: According to the model scheme shown in fig. 4 a strut is formed between the recess boxes of the precast elements facing each other. The tension load is transferred to the overlapping cable loops.

Fig. 3: Shear load parallel to the joint

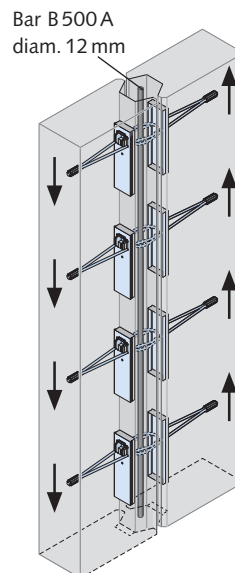
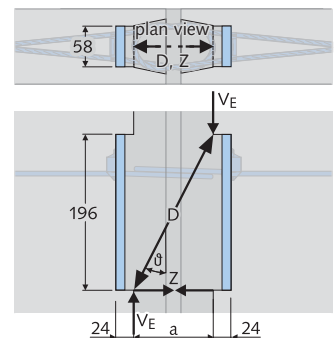

Fig. 4: Model for shear load parallel to the joint



HALFEN HLB LOOP BOX

Information on the constructive load bearing behaviour

3. Transfer of shear loads perpendicular to the joint

For the transfer of shear loads perpendicular to the joint (fig. 5) the geometry of the joint is particularly important. It can be assumed, that between the concrete flanks of the opposing precast elements a strut is formed according to fig. 6. The tension load is transferred to the overlapping cable loops.

It is recommended to carry out the calculation in the same way as for unreinforced slab joints, wherein the geometry is to be considered.

Fig. 5: Shear load perpendicular to the joint

Bar B 500 A
diam. 12 mm

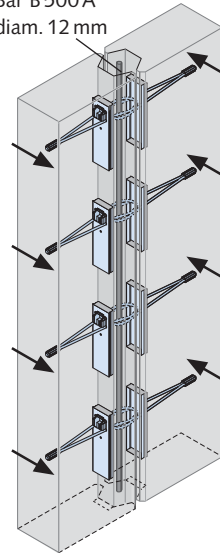
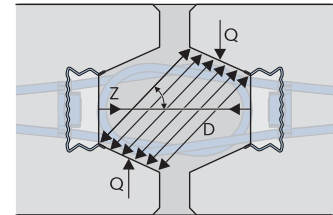

Fig. 6: Model for shear load perpendicular to the joint



Notes for fire protection

Regarding the fire protection the relevant regulations apply.

The cable loop of the HALFEN HLB Loop Box consists of a steel wire strength class 1770. It is commonly used in reinforced concrete structures. Therefore the regulations for reinforcement steel and for tensioning cables are to be observed.

In this connection the breaking stresses of the reinforcement steel and the cable loops at high temperatures have to be checked.

Furthermore, different demands are made on the centre distances for reinforcement steel and for tensioning cables. The minimum dimensions for the centre distances and further details of the constructive design depend on the required fire resistance class.

HALFEN HLB LOOP BOX

Installation instructions

Installation tolerances according to the official approvals, recommended also for applications designed as constructive junctions

• **horizontal**

Regular joint: 20 mm

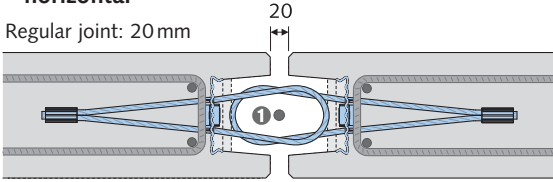

Minimum joint: 10 mm

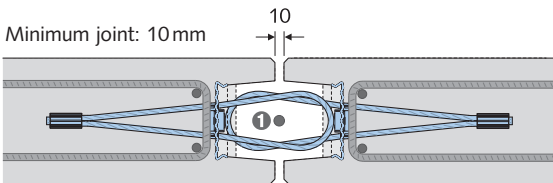

Maximum joint: 40 mm

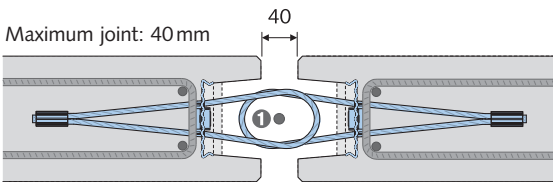

Bar B 500 A, diam. 12 mm

• **vertical**

Regular arrangement: loops at the same level

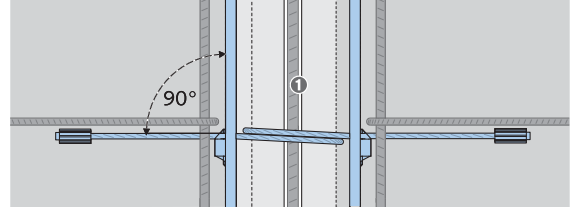

Vertical tolerance: maximum 20 mm

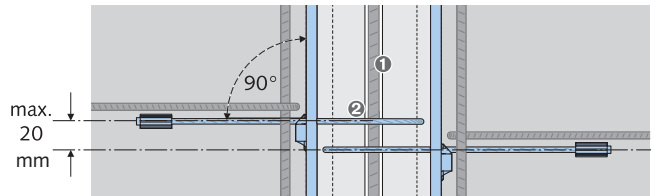

① Bar B 500 A, diam. 12 mm

② A vertical tolerance of maximum 20 mm is permissible. Wire binding of the cable loops is not compulsory.



Note: Welding on HLB Loop Box elements is not permitted.

Dry grout per meter joint length [kg/m]; joint: 2 cm		
Wall thickness [cm]	HLB M- 50 + HLB M- 50	HLB M- 20+ HLB M-100
14	16.7	22.1
16	17.5	22.9
18	18.3	23.7
20	19.1	24.5
22	19.9	25.3
24	20.7	26.1
26	21.5	26.9

On the construction site:

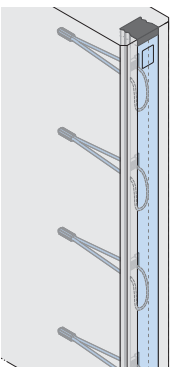

1. State of delivery with closed HLB Loop Box

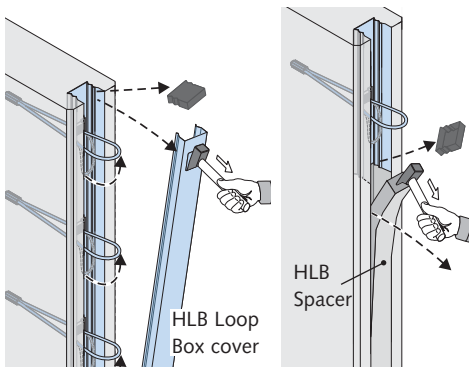

2. Remove the HLB Loop Box cover: strike in the pre-punched hole and pull out the steel cover, using an appropriate tool, e.g. a carpenter's hammer. Remove end covers (adhesive tape).

If HLB Spacers are incorporated, they must be removed, using an appropriate tool.

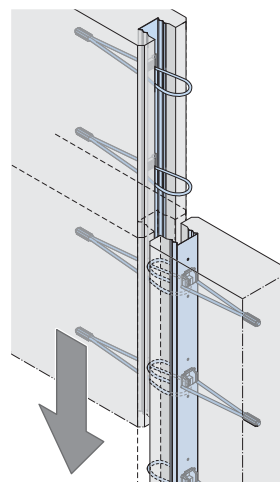

3. Setting up the precast element. The wire loops must stick out perpendicular to the joint, and after deflection during the setting up they should spring back into this position.

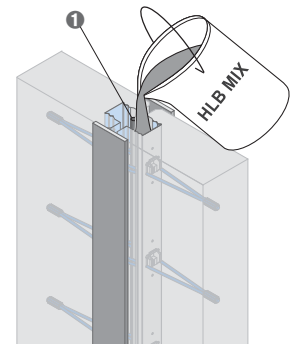

4. Insert the reinforcement bar diam. 12 mm and encase the joint with appropriate formwork. Prepare the HLB Mix joint grout according to the manufacturer's instructions. The maximum grouting height is 3.5 m. HLB Mix joint grout is capable of flowing, no additional compaction is required.

HALFEN HLB LOOP BOX

In-situ joint grout filling

HALFEN HLB Mix joint grout for producing a load bearing joint fill without further compaction

According to the official approval HLB Mix grout must be used for filling the joint. Mixing and applying the grout should be carried out with reasonable care, the manufacturers instructions are to be observed.

Properties of the HLB Mix joint grout:

- Graining 0...5 mm
- Consistency: capable of flowing, subsequent compaction is not necessary
- Maximum workability time at 20°C: 90 min, pumpable
- Guide value for the cube compression strength (150 mm), tested at 20 °C:
 - after 24 hours: minimum 40 N/mm²
 - after 28 days: compression strength grade C60/75
- shrinkage class SKVB II
- resistant to frost and de-icing salt



Delivery form: bags à 25 kg (for about 12.5 l of grout)

Storage: durable for 9 months storage in package and dry conditions.

Order example for HLB Mix joint grout:

HLB Mix grout 25 kg, Article no. **0058.060-00001**

Mixing:

Mix the HLB Mix joint grout with approx. 2.5 l to 3.0 l of water. Pour the water into the compulsory Mixer ①, leaving a remaining quantity, add the grout, and after a short period of mixing ② pour in the remaining quantity of water ③ and mix for at least 5 minutes ④.

Substrate:

The substrate must be well cleaned. Loose particles which prevent adhesion, i.e. cement sludge, moulding grease etc. must be completely removed by air blasting or similar treatment. It must have a minimum breakaway resistance of $\geq 1.5\text{N/mm}^2$ and sufficient bearing strength. The substrate must be sufficiently pre-watered!

Joint moulding, additional reinforcement bar:

Usually a spacing is left between the edges of the abutting precast elements. After connecting the loops of the HLB Loop Boxes with a reinforcement bar ⑤, the joints between the 2 elements are encased with formwork. For high elements or if the formwork allows no high pressure, the grout casting should be carried out in 2 steps.

Filling the joint ⑥:

The grout is poured in continuously up to the required filling height. Observe the height limit: the maximum height for pouring the HLB grout mix is limited to a **maximum of 3.50 m**, if necessary the grout must be filled in using a hose, or the height of the casting channel must be limited accordingly. The compaction may be facilitated using an internal spud vibrator or by poking. The temperatures of the environment and the building structure should be not below +5°C during the preparation of the grout and until 36 hours after pouring.

Preparation of the HLB Mix joint grout

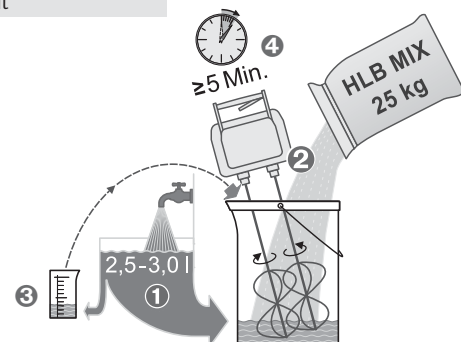

Joint filling

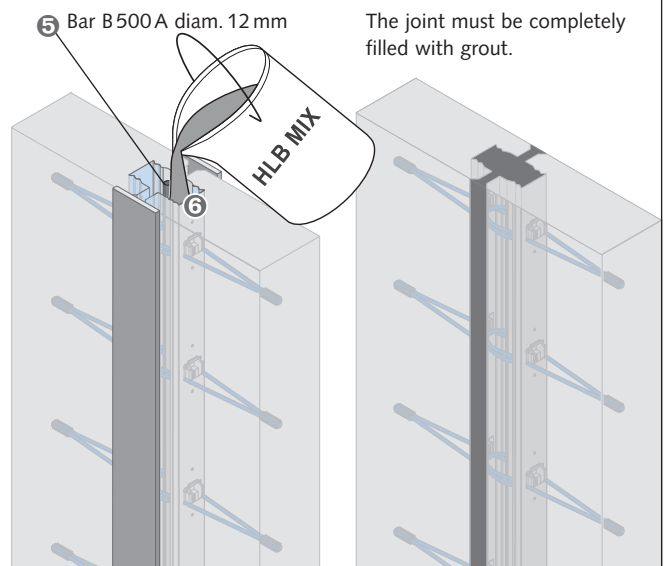

The joint must be completely filled with grout.

HALFEN HLB LOOP BOX

Order form

Enquiry Order

(Please mark your option)

Please send back to HALFEN via FAX

– Select contact data for your subsidiary from this catalogue's last page –

Construction project:

Company

Street

Postcode / City

Contact person

Phone

Fax

E-Mail

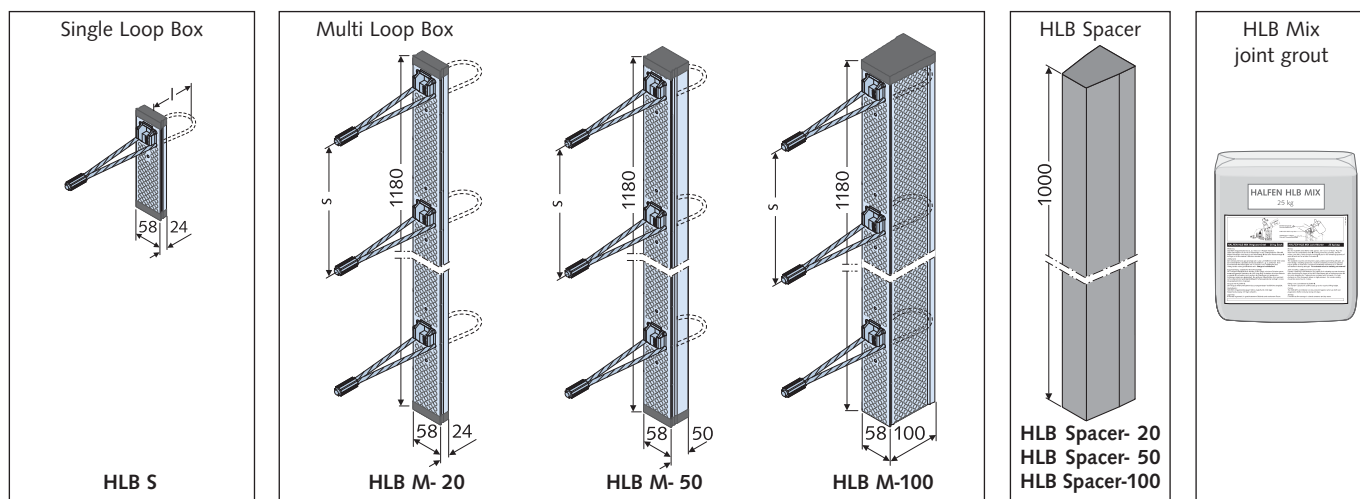

Pos.	Type	Quantity [piece]	Order no.	Unit price [EUR]	Total price per pos. [EUR]
Sum: plus packing and shipping costs					EUR

Delivery address:
(only if the delivery address is not identical with the ordering address)

Date,
signature

CONTACT HALFEN WORLDWIDE

HALFEN is represented by subsidiaries in the following 14 countries, please contact us:

Austria	HALFEN Gesellschaft m.b.H. Leonard-Bernstein-Str. 10 1220 Wien	Phone: +43-1-259 6770 E-Mail: office@halfen.at Internet: www.halfen.at	Fax: +43-1-259-677099
Belgium/ Luxembourg	HALFEN N.V. Borkelstraat 131 2900 Schoten	Phone: +32-3-658 07 20 E-Mail: info@halfen.be Internet: www.halfen.be	Fax: +32-3-658 15 33
China	HALFEN Construction Accessories Distribution Co.Ltd. Room 601 Tower D, Vantone Centre No. A6 Chao Yang Men Wai Street Chaoyang District Beijing · P.R. China 100020	Phone: +86-10 5907 3200 E-Mail: info@halfen.cn Internet: www.halfen.cn	Fax: +86-10 5907 3218
Czech Republic	HALFEN s.r.o. Business Center Šafránkova Šafránkova 1238/1 155 00 Praha 5	Phone: +420-311-690 060 E-Mail: info@halfen-deha.cz Internet: www.halfen-deha.cz	Fax: +420-235-314 308
France	HALFEN S.A.S. 18, rue Goubet 75019 Paris	Phone: +33-1- 445231 00 E-Mail: halfen@halfen.fr Internet: www.halfen.fr	Fax: +33-1-445231 52
Germany	HALFEN Vertriebsgesellschaft mbH Liebigstr. 14 40764 Langenfeld	Phone: +49-2173-970-0 E-Mail: info@halfen.de Internet: www.halfen.de	Fax: +49-2173-970 225
Italy	HALFEN S.r.l. Soc. Unipersonale Via F.lli Bronzetti N° 28 24124 Bergamo	Phone: +39-035-0760711 E-Mail: tecnico@halfen.it Internet: www.halfen.it	Fax: +39-035-0760799
Netherlands	HALFEN b.v. Oostermaat 3 7623 CS Borne	Phone: +31-74-267 14 49 E-Mail: info@halfen.nl Internet: www.halfen.nl	Fax: +31-74-267 26 59
Norway	HALFEN AS Postboks 2080 4095 Stavanger	Phone: +47-51 82 34 00 E-Mail: post@halfen.no Internet: www.halfen.no	Fax: +47-51 82 34 01
Poland	HALFEN Sp. z o.o. Ul. Obornicka 287 60-691 Poznan	Phone: +48-61-622 14 14 E-Mail: info@halfen.pl Internet: www.halfen.pl	Fax: +48-61-622 14 15
Sweden	Halfen AB Vädursgatan 5 412 50 Göteborg	Phone: +46-31-98 58 00 E-Mail: info@halfen.se Internet: www.halfen.se	Fax: +46-31-98 58 01
Switzerland	HALFEN Swiss AG Hertistrasse 25 8304 Wallisellen	Phone: +41-44-849 78 78 E-Mail: mail@halfen.ch Internet: www.halfen.ch	Fax: +41-44-849 78 79
United Kingdom/ Ireland	HALFEN Ltd. A1/A2 Portland Close Houghton Regis LU5 5AW	Phone: +44-1582-47 03 00 E-Mail: info@halfen.co.uk Internet: www.halfen.co.uk	Fax: +44-1582-47 03 04
United States of America	HALFEN USA Inc. 8521 FM 1976 P.O. Box 547 Converse, TX 78109	Phone: +1 800.423.91 40 E-Mail: info@halfenusa.com Internet: www.halfenusa.com	Fax: +1 877.683.4910
For countries not listed HALFEN International	HALFEN International GmbH Liebigstr. 14 40764 Langenfeld /Germany	Phone: +49-2173-970-0 E-Mail: info@halfen.com Internet: www.halfen.com	Fax: +49-2173-970-849

Furthermore HALFEN is represented with sales offices and distributors worldwide. Please contact us: www.halfen.com

NOTES REGARDING THIS CATALOGUE

Technical and design changes reserved. The information in this publication is based on state-of-the-art technology at the time of publication. We reserve the right to make technical and design changes at any time. HALFEN GmbH shall not accept liability for the accuracy of the information in this publication or for any printing errors.

The Quality Management System of Halfen GmbH is certified for the locations in Germany, France, the Netherlands, Austria, Poland, Switzerland and the Czech Republic according to **DIN EN ISO 9001:2008**, Certificate No. QS-281 HH.





For further information please contact: www.halfen.com