

# **ALUMINIUM TRADITIONAL ROUND CAST DOWNPIPES**

Inspired by the 19th century Cast Iron Downpipes



63

75

100

150

**IF YOU DONT SEE WHAT YOU WANT - PLEASE ASK**

# Aluminium Traditional Round Cast Downpipes

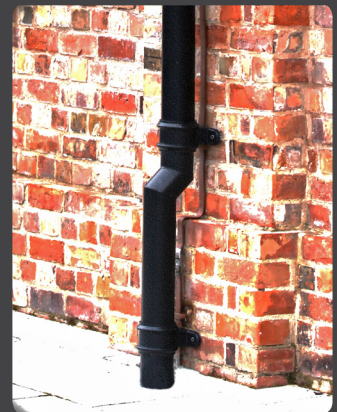

INSPIRED  
BY THE  
19<sup>TH</sup>  
CENTURY  
CAST IRON  
DOWNPIPES

***Aluminium - the Responsible Eco-choice***

**GUTTERCREST**

[www.guttercrest.co.uk](http://www.guttercrest.co.uk)

# Aluminium Traditional Round Cast Downpipes



INSPIRED  
BY THE  
19<sup>TH</sup>  
CENTURY  
CAST IRON  
DOWNPIPES

***Aluminium - the Responsible Eco-choice***

**GUTTERCREST**

[www.guttercrest.co.uk](http://www.guttercrest.co.uk)

# TRADITIONAL ROUND DOWNPIPES AND FITTINGS

## ROUND DOWNPIPES

Pipe (mm)	3mtr	1.8mtr	1.5mtr	1mtr	Other Specify length	Wall Thickness	A
63	RW1T/1	RW1T/3	RW1T/4	RW1T/5	RW1T/6	1.6	76
75	RW2T/1	RW2T/3	RW2T/4	RW2T/5	RW2T/6	1.6	76
100	RW3T/1	RW3T/3	RW3T/4	RW3T/5	RW3T/6	1.6	100
150	RW5T/1	RW5T/3	RW5T/4	RW5T/5	RW5T/6	2.5	112

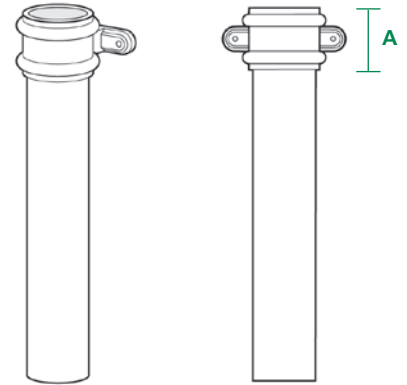

## ACCESS PIPES & PLATES

Pipe (mm)	Access Pipe complete with plate	Access Plate	A
63	RW1T/8	RW1T/9	100
75	RW2T/8	RW2T/9	100
100	RW3T/8	RW3T/9	130
150	RW5T/8	RW5T/9	200

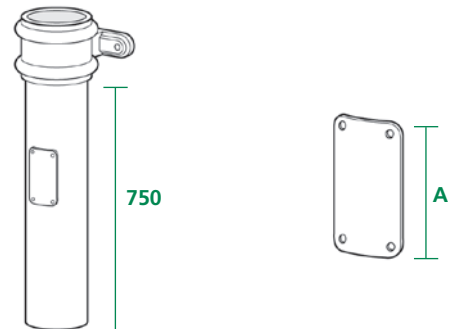

## SHOES

Pipe (mm)	Shoe	A	B
63	RW1T/10	140	95
75	RW2T/10	155	105
100	RW3T/10	180	130
150	RW5T/10	235	180

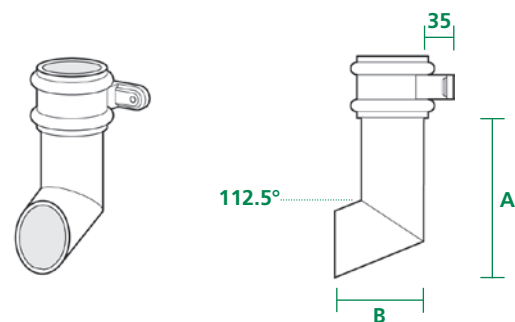

# TRADITIONAL ROUND DOWNPIPES AND FITTINGS

## BRANCHES

Pipe (mm)	Branch	A	B	C
63	RW1T/11	320	150	140
75	RW2T/11	335	150	145
100	RW3T/11	360	150	155
150	RW5T/11	410	150	205

Note: universal branch for left or right hand. If one piece required please state including left or right hand.

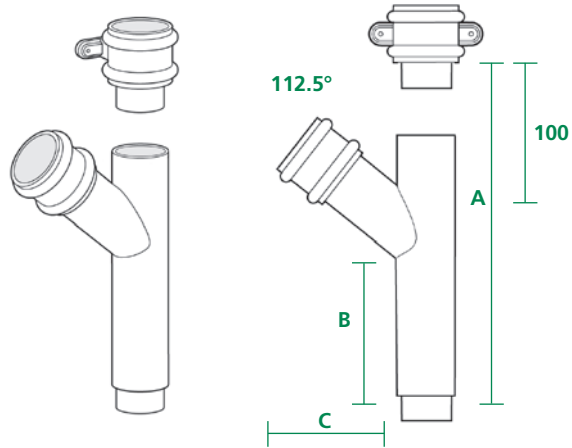

## CONNECTORS

Pipe (mm)	Connector (no ears)	Connector (ears)	A	B
63	RW1T/12	RW1T/13	76	50
75	RW2T/12	RW2T/13	76	50
100	RW3T/12	RW3T/13	100	50
150	RW5T/12	RW5T/13	112	60

Note: a standard plain connector can also be used

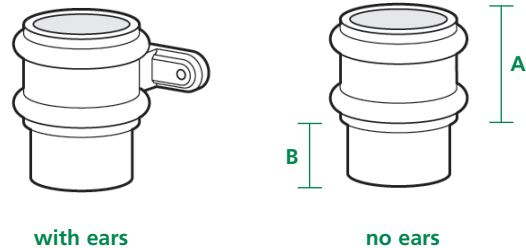

## COLLAR BRACKETS

Pipe (mm)	Pipe Clip	A	B
63	RW1T/15	76	140
75	RW2T/15	76	155
100	RW3T/15	100	200
150	RW5T/15	112	235

This item is used in place of a bracket i.e. at the base of the downpipe if no shoe is required

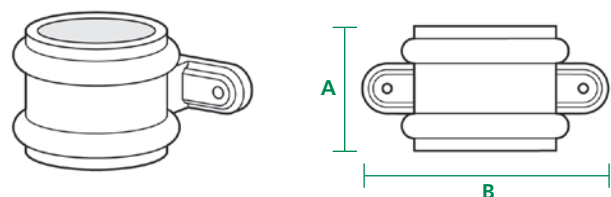

# TRADITIONAL ROUND DOWNPIPES AND FITTINGS

## BENDS

Pipe (mm)	Bend (no ears)	Bend (ears)	A	B
63	RW1T/21	RW1T/22	125	20
75	RW2T/21	RW2T/22	125	20
100	RW3T/21	RW3T/22	125	20
150	RW5T/21	RW5T/22	125	20

Note: Universal bend for right or left hand. If one piece required please state including if right or left hand.

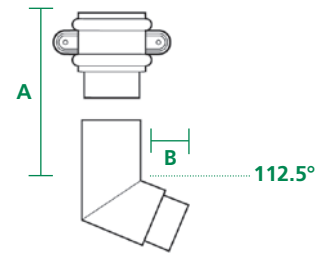
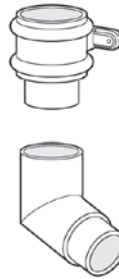

supplied with ears as standard

## PLINTH OFFSETS

Pipe (mm)	Ref	A	B	P
63	RW1T/23	165	200	Please state size required
75	RW2T/23	170	200	
100	RW3T/23	180	200	
150	RW5T/23	240	200	

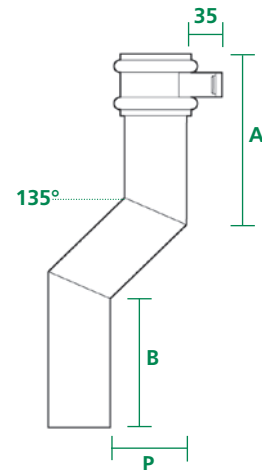
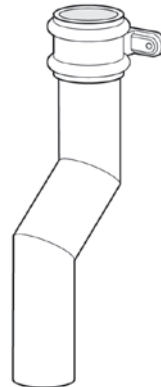

## SWAN NECKS

Pipe (mm)	one piece State size	Maximum projection of swan necks						Other	Minimum Projection P
		300	450	600	900	1200			
63	RW1T/25	RW1T/26	RW1T/27	RW1T/28	RW1T/29	RW1T/30	Please specify A, B and P, projection angle RW?/31	105	
75	RW2T/25	RW2T/26	RW2T/27	RW2T/28	RW2T/29	RW2T/30		115	
100	RW3T/25	RW3T/26	RW3T/27	RW3T/28	RW3T/29	RW3T/30		130	
150	RW5T/25	RW5T/26	RW5T/27	RW5T/28	RW5T/29	RW5T/30		170	

