

Gripple Y Pipe Hanger

Y pipe hanger provides a quick and easy way to suspend pipework without the need for traditional supports and bearers.

PRODUCT INFORMATION

- Allows quick fixing of pipe brackets to M8 stud fixing.
- Provides easy access to fit insulation to piping.
- 50% less drilling with one single anchoring point.
- Supplied as a ready to use kit.
- Two legs provide support improving the centre of gravity.
- Y-Fit accessory suitable for long drops with standard Gripple hanger kits.
- Designed to support two pipes 10mm-65mm.
- Insulation can be fitted on 19mm and 32mm diameter pipe.
- Choice of spacing allows two pipes to be fitted at 100mm, 150mm and 200mm.

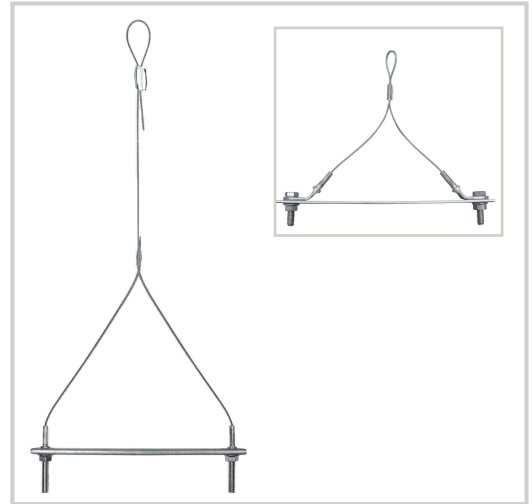

INSTALLATION



1. Fix using wire anchor, eyelet anchor or M6/M8 adaptor into concrete.



2. Attach pipe clamps to M8 studs.

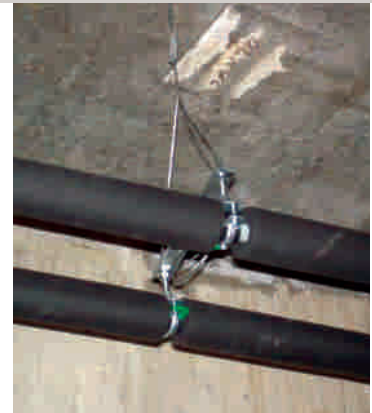

3. Fix pipes into pipe clamps.

Y-PIPE HANGER SPECIFICATION

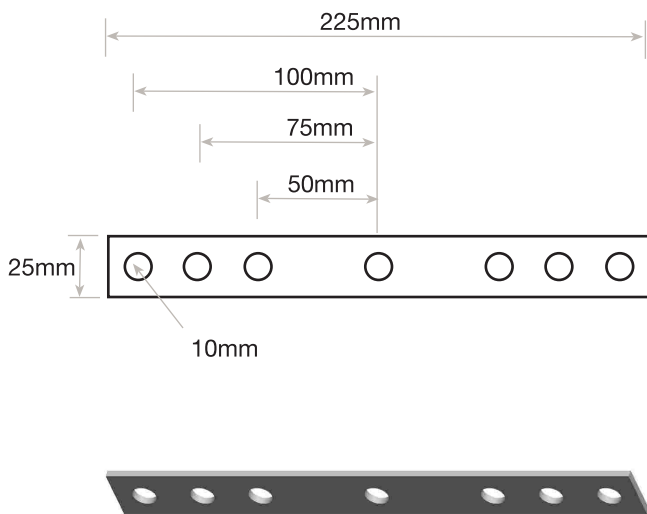

Important Information

1. Construction materials and conditions vary on different sites. If it is suspected that the base material has insufficient strength to achieve a suitable fixing, contact Gripple Ltd. The responsibility for judgement of base material strength lies with the installer, and not with Gripple Ltd.
2. The information and recommendations given herein are believed to be correct at time of writing. The data has been obtained from tests done under laboratory, or other controlled conditions and it is the users responsibility to use the data given in light of conditions on site, taking account of the intended use of the products concerned.
3. Whilst Gripple Ltd can give general guidance and advice, the nature of Gripple products means that the ultimate responsibility for selecting the correct product for a particular application must lie with the customer.
4. All products must be used, handled and applied in accordance with current product instructions and manufacturers recommendations for use, published by Gripple Ltd.
5. Gripple's policy is one of continuous development and innovation. We therefore reserve the right to alter specifications, etc. without notice.