

Gripple Magnetic pad

Magnetic pad enables quick and easy installation of signage and other services to metal surfaces.

PRODUCT INFORMATION

- Enables quick and easy installation of signage and other services to metal surfaces
- Requires no drilling or power tools
- Available in Gripple hanger size No.1 only
- Rated at 10kg safe load with a 2:1 safety factor
- Supplied in a ready-to use kit with a length of wire rope
- Load may vary depending on the thickness of the steel



INSTALLATION

1. Attach the magnet to the metal surface.
2. Height is adjusted using Gripple kit.
3. Remove and reposition as required.

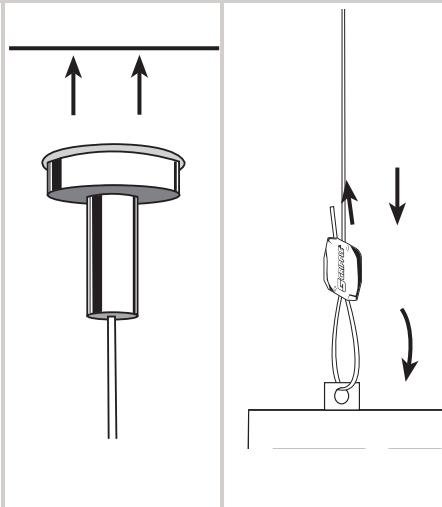

MAGNET SPECIFICATION

Size	A mm	B mm	C mm
No.1	25	8	45

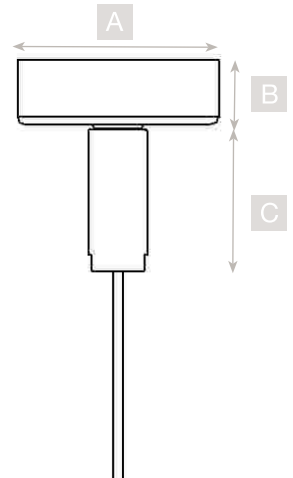

MAGNET - DO'S AND DONT'S

- Magnets only attract to ferrous materials e.g. steel products including galvanised steel and iron based products.
- Magnets do not attract to aluminium, plastic or brass.
- Maximum working temperature 80°C.
- Handle with care-magnets are strong. Wear protective gloves and handle carefully to avoid trapping of skin.
- Magnets are brittle; do not allow them to 'crash' together as pieces may break off.
- Magnets can magnetically damage sensitive equipment when brought into close proximity, e.g. televisions, computer screens and discs, pacemakers, credit cards, store cards, telephone cards etc.
- Magnetic pull strength figures are based on the full magnetic flux being absorbed and can vary with the thickness of the material to which the magnet is attached.

Important Information

1. Construction materials and conditions vary on different sites. If it is suspected that the base material has insufficient strength to achieve a suitable fixing, contact Gripple Ltd. The responsibility for judgement of base material strength lies with the installer, and not with Gripple Ltd.
2. The information and recommendations given herein are believed to be correct at time of writing. The data has been obtained from tests done under laboratory, or other controlled conditions and it is the users responsibility to use the data given in light of conditions on site, taking account of the intended use of the products concerned.
3. Whilst Gripple Ltd can give general guidance and advice, the nature of Gripple products means that the ultimate responsibility for selecting the correct product for a particular application must lie with the customer.
4. All products must be used, handled and applied in accordance with current product instructions and manufacturers recommendations for use, published by Gripple Ltd.
5. Gripple's policy is one of continuous development and innovation. We therefore reserve the right to alter specifications, etc. without notice.