

Gripple Express No.1



The Gripple Express is a fast locking solution for quick and easy suspension of signage, shopfitting display, HVAC, plumbing, cable containment and lighting.

ADVANTAGES

- Up to 6 times faster to install than traditional methods
- Keyless - no tool required for adjustment
- Ergonomic buttons allow rapid adjustment
- Discreet and aesthetic design
- XP1 load rated at 15 kg with a 5:1 safety factor
- Supplied as a ready-to-use kit



INSTALLATION

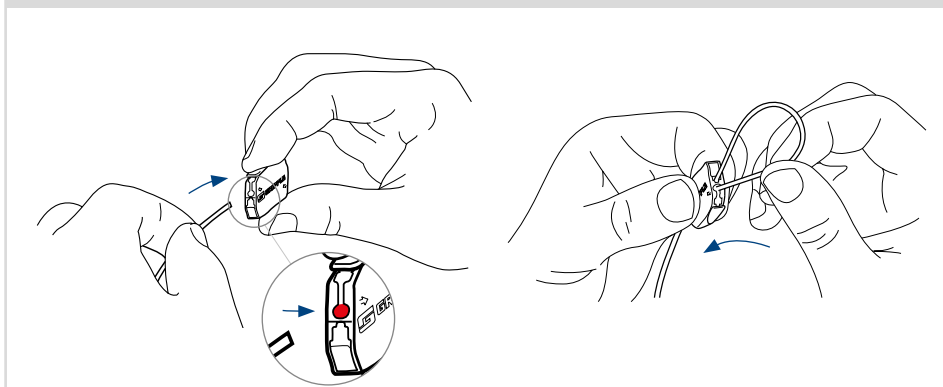

RELEASE

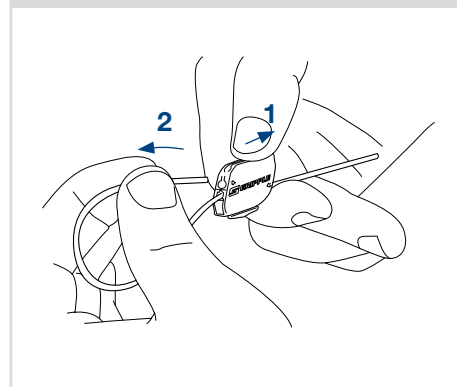

PRODUCT DIMENSIONS

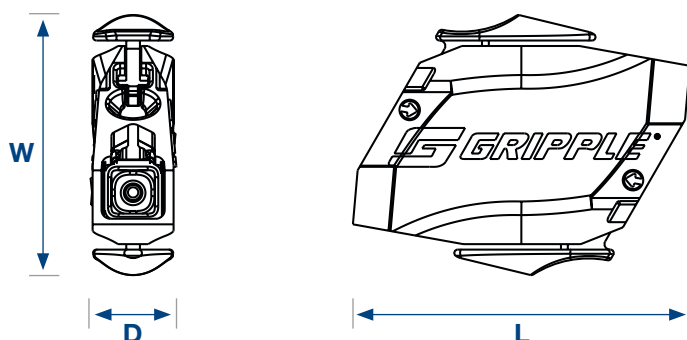

Wire rope diameter	L (mm)	W (mm)	D (mm)
1.5 mm	23.5	18.5	5.9

* This product is silicone free

END FIXING

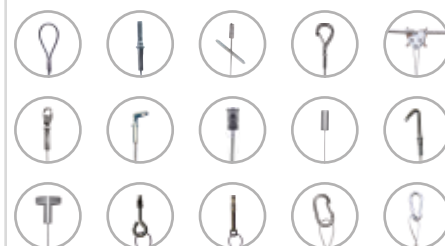

Each ready-to-use kit comes with an end fixing of your choice. All types can be ordered to the length you require (up to 10 metres or more).

For further detailed information on any of our end fixings, please visit our website or contact us using the information below.