

grasscrete®

CAST INSITU PAVING SYSTEM

**LAYING GUIDE:
SLOPE PROTECTION WORKS**

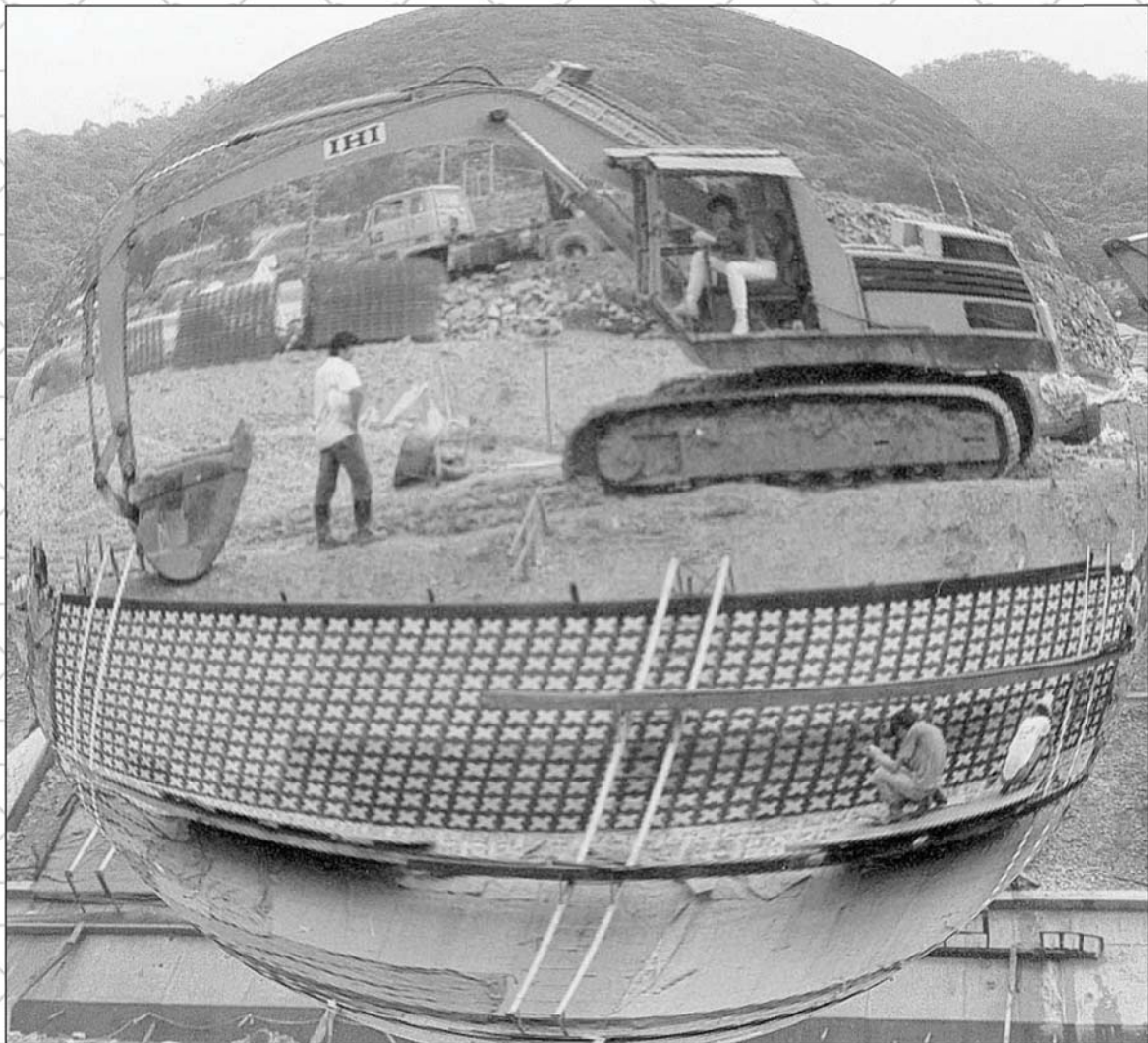

GrassConcrete

GRASSCRETE – A CONTRACTORS GUIDE

WHAT IS GRASSCRETE?

When in place GRASSCRETE is a cellular reinforced concrete slab. Its structure places no reliance upon grass for stability and, therefore, its capabilities far exceed that of precast blocks with which it is often confused.

GRASSCRETE is cast on site by pouring concrete over plastic formers. This guide is intended to provide a step by step insight into the best techniques in construction.

PREPARATION

The suitability of the sub-soil should be assessed relative to the slope angle. In this respect, it should be remembered that grass and concrete paving generally is an armour layer and not an earth retention system.

Unstable ground will need to be identified and appropriate measures introduced to stabilise weak ground ahead of constructing a revetment armour layer.

The preparation can be divided into two classifications subject to location and load.

Channel inverts

This application is likely to involve vehicular use upon completion for maintenance purposes along the invert bed. To transmit load safely under waterlogged conditions a granular sub-base should be provided.

Assuming an allowable ground bearing capability of 45kN/m^2 , a sub-base depth of 150mm will be sufficient and should be blinded with a screeded 20mm thick layer of sharp concreting sand. In waterborne applications we recommend the installation of a geotextile membrane between sub-base and sub-grade (Fig. 1). Preparation tolerance for the sub-base should be $\pm 18\text{mm}$.

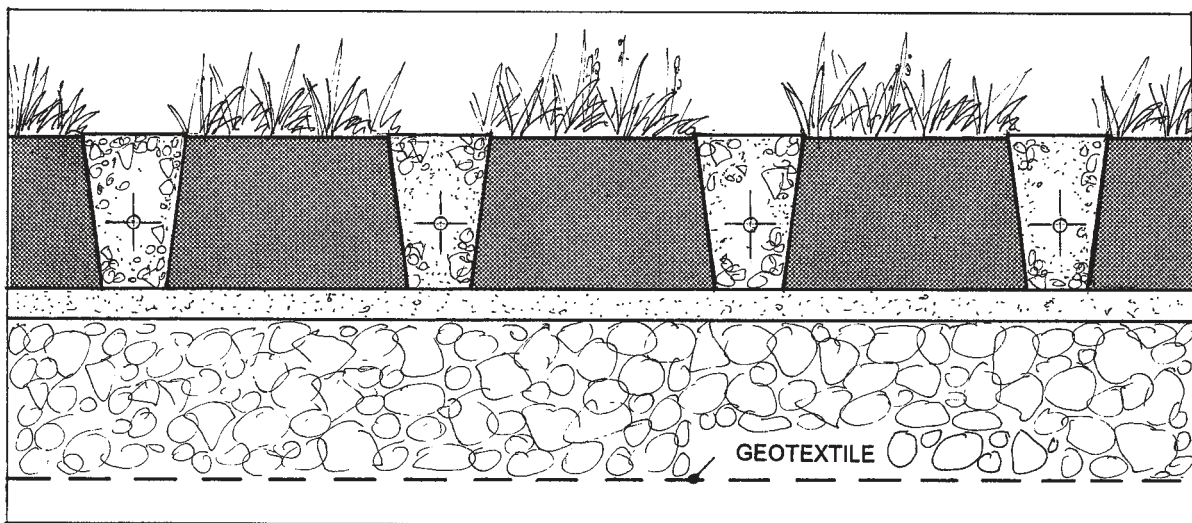

Fig. 1

Slopes

Steep slopes preclude the use of sub-base layers and in the absence of vehicular movement is not a structural requirement anyway.

The excavation and preparation of the side slopes will normally involve a number of stages:

- 1) bulk excavation to general profile
- 2) fine grading using excavator mounted ditching bucket
- 3) hand trimming to remove loose material, etc.

Stage 2) of the works should be undertaken at a rate geared to construction of the paving layer. Long term delays between preparation and capping should be avoided particularly during rainy seasons. Any deterioration of the preparation will result in soft or slipped material needing to be removed and new selected material being introduced to reinstate levels.

For steep slopes the target tolerance should be $\pm 25\text{mm}$, the increase being accounted for by the loss of a sub-base regulation layer.

The sand blind should ideally be a coarse grit sand blinded to an optimum screened depth of 25mm. For waterborne applications we recommend the installation of a geotextile membrane which for side slopes should ideally be positioned over the sand blind.

Once in place, and immediately prior to laying the GRASSCRETE, the geotextile membrane should be dusted with a fine layer of sharp sand to guard against subsequent damage to the geotextile during construction (Fig. 2).

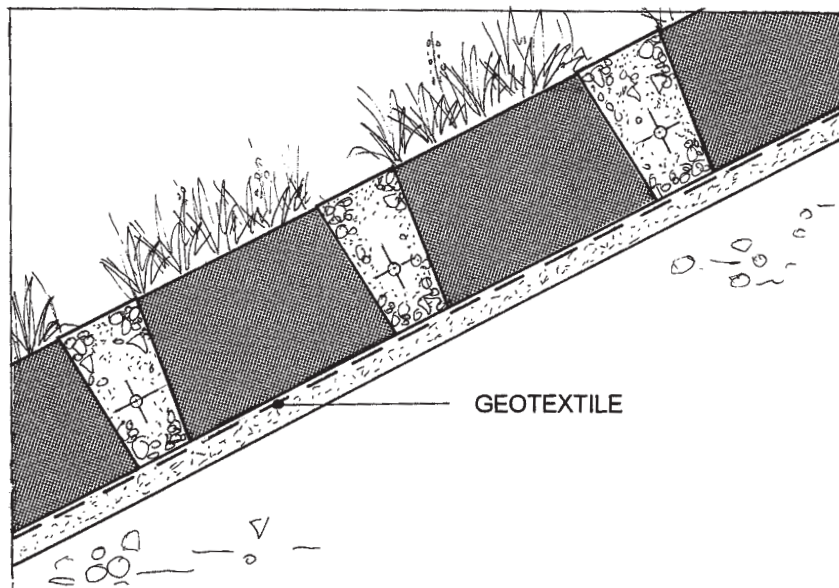

Fig 2

HANDLING OF FORMERS

GRASSCRETE formers are provided in nests with individual pieces factory coated with a release agent to resist over compaction during delivery and handling.

Care should be taken during handling to prevent damage to formers. They should also be covered in their stockpiles to guard against ultra-violet light, long term exposure to which can eventually make the material brittle. For these reasons we recommend that formers be delivered from the storage area to the work area on a daily allocation.

Edges of the formers can be sharp. We recommend, therefore, the habitual wearing of gloves. Unused formers should not be left on site de-nested as they are then susceptible to wind displacement. It is normally sufficient to hold down a stockpile with a sheet of mesh reinforcement.

When stacking formers they should be placed on edge rather than laid flat to protect against overcompaction (Fig. 3).

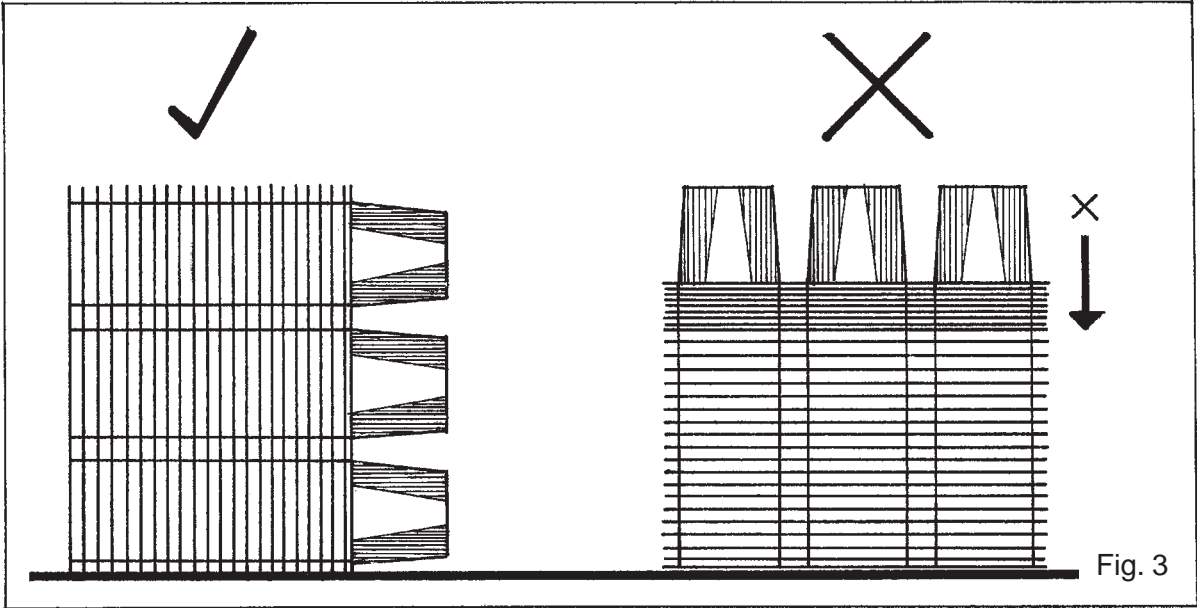

ERECTION OF FORMWORK

Prior to placement of the final sand layer, edge formwork should be erected to the outer perimeter of the casting bay. With a relatively low live load for the cellular concrete, a simple formwork design is all that is called for and in most cases a steel roadform will be sufficient (Fig. 4).

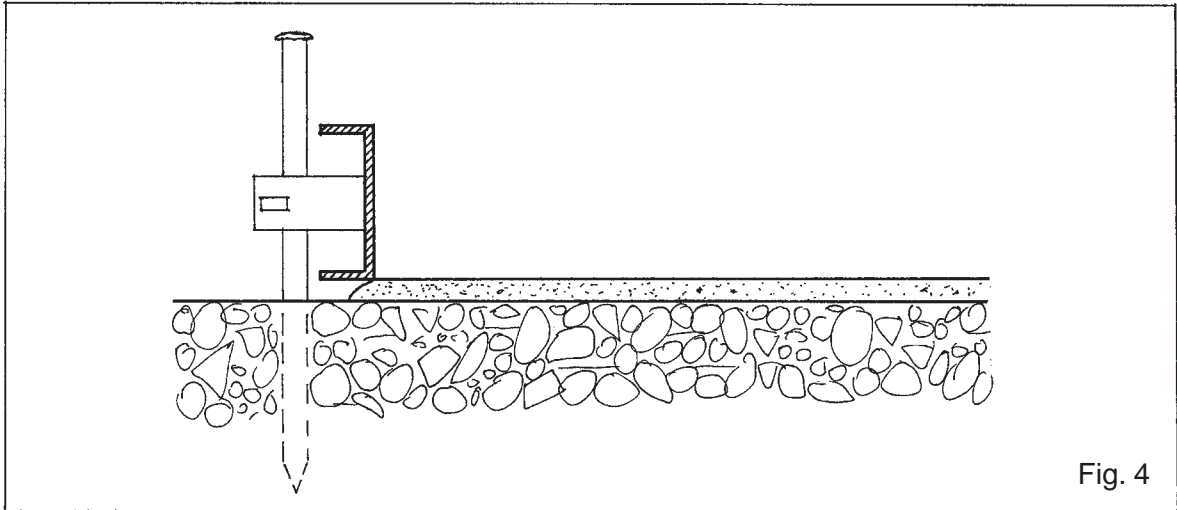

Where used on steep sided slopes it may be necessary to provide additional bracing to the shutter to resist overturning. Gaps in formwork, particularly to the underside, should be plugged with sand.

When casting to invert slabs, it is normal to pour on a continuous cycle the end shutter only being placed immediately prior to the final concrete being poured. This enables continuous access for construction plant.

PLACEMENT OF FORMERS

The depth of concrete poured is controlled by the depth of the former. Essentially, therefore, in tolerance terms the top surface will mirror that of the blinded preparation.

Having screeded the sand, formers can be positioned edge to edge on the sand commencing not less than 100mm away from either formwork or a previous bay (Fig. 5).

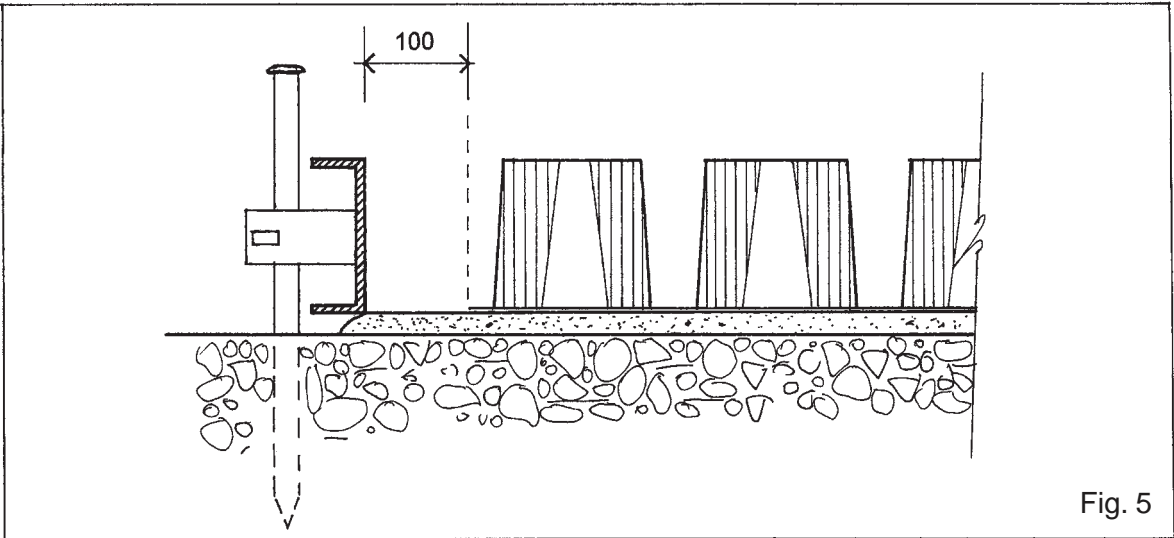

Where formers are cut down from their original 600mm module, the cut units should be positioned inboard within the bay. Positioning otherwise at the edges could lead to them moving unduly during casting.

From time to time during placement of the formers we recommend that they be checked for overall level. This can be checked in advance of laying formers by holding a string line across the bay and passing a single former underneath. If the former does not touch the stringline then when cast the concrete will cover the formers causing difficulty in the subsequent melting process.

Where expansion joints are located, the adjacent former should be positioned not less than 100mm from the joint filler.

At changes of direction, a transition joint should be formed with the GRASSCRETE formers being cut tangential to the joint.

During summer months, lay in position only sufficient formers to be able to pour the next load of concrete. In temperatures in excess of 30° prolonged exposure to heat can result in a slight softening of the plastic.

After positioning formers ensure that the 100mm gap between the former and the shutter face is not constricted by sand build up against the shutter face.

PLACEMENT OF MESH REINFORCEMENT

The plastic former is manufactured to the same 200 x 200mm module as the mesh reinforcement with the latter being positioned on integrally moulded chair up spacers located between the main upstand of the former (Fig. 6).

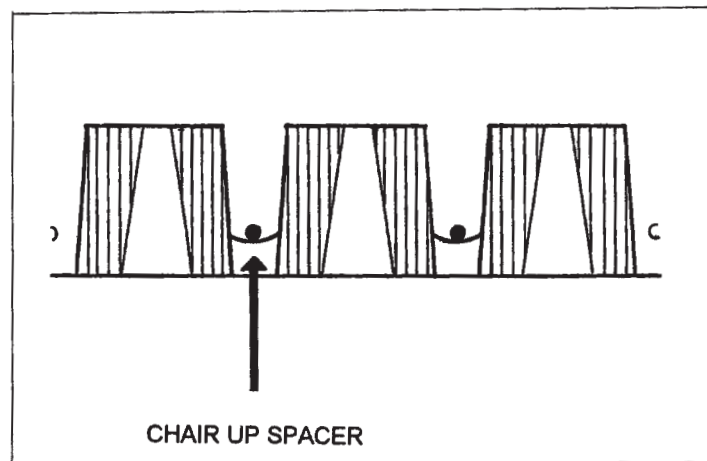

Fig. 6

The chair up spacer is concave in section to encourage the mesh and former to self centre. There are, however, a number of factors that limit the ability to fully centre each former:

- i) Tolerance in the formation will alter the true plan area of the sub-grade. Where overlaying with modular units of set dimension, there will inevitably be a need for some compensation in alignment that will cause the former to locate slightly off centre from the mesh.
- ii) Mesh reinforcement though described as a 200 x 200mm module will vary within permissible tolerances.
- iii) When lapping mesh, wires will be located side by side within the interstices.

Before cutting to the perimeter of the bay we recommend lifting slightly one end of a mesh sheet followed by a short right to left and back flick movement. This tends to naturally bring the formers into line.

To the perimeter the mesh should then be cut back to form end cover relevant to the appropriate National Code. For mesh up to 8mm diameter, this is best achieved using long handled bolt croppers. Above that size a mechanical saw should be utilised.

When placing reinforcement to the GC3 (76mm deep) system, care should be taken to ensure that the mesh neither a) dips into the sand at the 100mm margin (utilise a carborundum spacer if required) or b) rises off the chair spacers due to bending of the smaller diameter wires. When using reinforcement with 6mm diameter wires, we recommend that the material be stockpiled only on level ground to prevent distortion of the sheet.

It is normally not necessary to tie the mesh reinforcement except where it fails to bed down at laps.

EXPANSION JOINTS

Methodology will be dictated by the type of joint and material used. For the purpose of this document, we consider standard filler details to be a combined expansion/contraction type without dowels.

The joints should be incorporated at maximum 10 x 10 metre centres with attention being paid to the location relative to curves where expansive forces should not be restricted.

Where rigid joint fillers are used they can be pinned in position with concrete poured through from bay to bay with pins withdrawn prior to trowelling edge margins.

Where fully flexible joint fillers are used, either a temporary rigid filler should be used or bays should be cast alternately to enable the filler to be placed against a previously cast face.

The joint can be sealed with a proprietary joint sealer though for a rigid filler this is not normally required.

PREPARATION FOR CONCRETE

By this stage, the method of placement will probably already have been determined. Placement methods for slopes and horizontal areas will differ and we, therefore, consider each separately.

Slopes

Due to the limitations of direct access to the full length of a slope pouring will tend to be via either a pump, 360° excavator or telescopic handler, the latter being utilised from a stand off position at the base of the slope.

With this sort of placement, the formers and mesh can be pre-set to full bay layouts without limitation.

Concrete should be poured on to staging boards to prevent impact damage to the plastic formers.

On the steepest slopes consideration should be given to the fact that the staging board cannot be used as a working platform. To cater for this, a separate working support can be achieved by a gallows bracket hooked over a ladder/stillage support (Fig. 7).



Horizontal

Assuming the incorporation of a granular sub-base, the formation could possibly be utilised to bring concrete deliveries direct to point of placement.

If this is so, then casting can take place as a continuous process with formers and mesh reinforcement being placed as the concrete truck is withdrawing along the bay.

Where this method is neither practical or desirable, then placement can be by either of the means previously described for slopes. In this instance however, the staging board can be utilised to both receive concrete and to provide a working platform

CONCRETE – MATERIAL SELECTION

Within the concrete mix design a number of key factors need to be considered:

- i) The maximum aggregate size should be 10mm, above that there is a potential for honeycombing as the aggregate bridges the gap between mesh reinforcement and former.
- ii) To encourage sufficient workability and to ensure aggregate locking under plasticised conditions the sand content as proportion of total aggregate should be in the region of 45%.
- iii) In applications where vehicular access is a requirement, the structural analysis of the GRASSCRETE section is based upon a 30N/mm² compressive strength. We recommend that for ease of identification a reference to a C30 mix should be standardised except where special circumstances demand a figure above that, i.e. in circumstances of extreme load or exposure.
- iv) The slump of the concrete will be dictated by the angle of placement. On horizontal applications flowing concrete can be utilised to gain optimum workability and compaction.

For sloping ground the concrete slump will need to be reduced. This can still utilise a superplasticiser which will enable a low water cement ratio to be used.

	<u>Horizontal</u>	<u>Sloping</u>
Mix designation	C30/10	C30/10
Compressive strength	30N/mm ² @ 28 days	30N/mm ² @ 28 days
Cement type	PC	PC
Minimum cement content	350kg/m ³	350kg/m ³
Maximum water/cement ratio	0.55	0.55
Aggregate size (max)	10mm	10mm
Sand/aggregate ratio	0.45	0.45
Air entrainment	3%±1 ¹ / ₂ %	3%±1 ¹ / ₂ %
Control slump	100mm	50mm
Superplasticiser dosage	To be determined	To be determined
Final slump	Flowing	75-100mm subject to slope angle

CONCRETE PLACEMENT

With the preparations in place, pouring can commence. To achieve both a good finish and a quick laying speed the concrete should be placed and levelled as one continuous process. Concrete should not be heaped on the plastic formers for finishing at a later stage.

The plastic formers are coated with a slip agent which helps to keep the tops of the formers free from latent concrete. For this to function, however, the concrete should be drawn tight to the upper level of the former so that the cruciform shape remains visible during the finishing process. If it is not, then there is too much concrete being placed.

Slopes

Methodology is very much controlled by the angle of the slope. On relatively shallow slopes the concrete can be fully filled in and around the formers on discharge with concrete allowed to 'run' in place.

On steep slopes, we recommend that the concrete be placed in two passes with the first pass filling the interstices to half depth. The second pass will then finish to the upper level of the formers.

The actual slump to be used for slopes should be determined on site by a preliminary trial mix, the determining factor being the optimum flow before becoming too fluid to remain in place. By using a superplasticiser any overdose will be mitigated by heat of hydration so that after 25-30 minutes it will start to revert to its control slump.

At lower slumps, utilised for slopes, the degree of natural compaction will be dictated to a significant degree by the aggregate shape. A rounded gravel will tend to work into the interstices whilst an irregular stone aggregate may need to be worked in place. In the case of the latter, a small diameter vibrating poker may be beneficial in gaining improved compaction. Care should be taken, however, not to damage the side walls of the formers during use.

The cruciform profile and ribbed side walls of the former provide significant benefit during placement. This reduces the risk of concrete sliding which would be encountered with rectangular or circular profiles.

Further benefit can be achieved by positioning a temporary stopboard longitudinally between the former upstands to limit flow if commencing the pour from the top of the slope (Fig. 8).

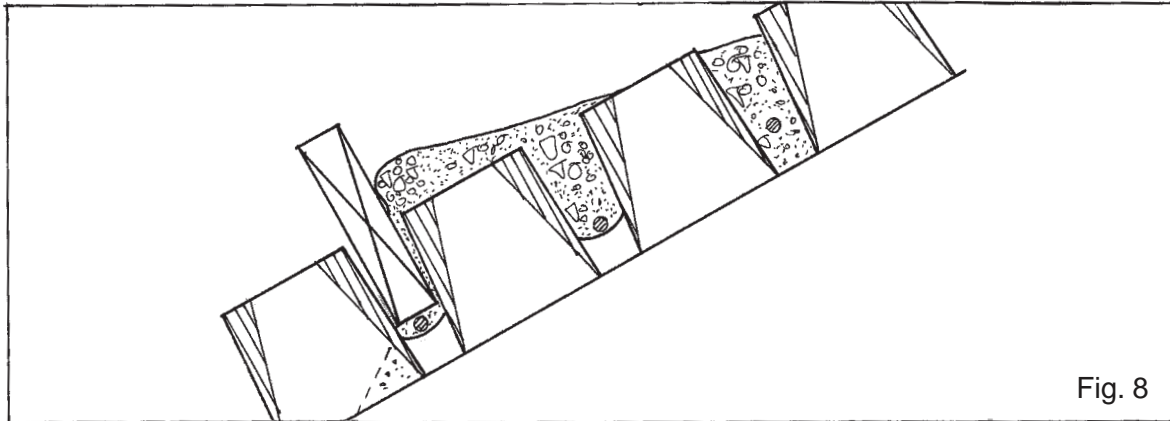

Fig. 8

Horizontal

Utilising free flowing concrete, little double handling should be required with concrete being easily drawn across the formers tops. No further compaction is required as the flowing concrete will naturally fill the interstices.

The placement can be made by either direct pour or double handling as previously described.

For both horizontal and sloping applications, the concrete should be finished by a rubber bladed aluminium squeegee (available from Grass Concrete Limited). The angled profile of this tool enables concrete to be pulled with the squeegee face flat to the former or drawn and finished with the blade facing downward (Fig. 9). Concrete should be drawn tight to the top of the formers with the squeegee worked diagonally across the bay to prevent it from dropping into the concrete ribs.

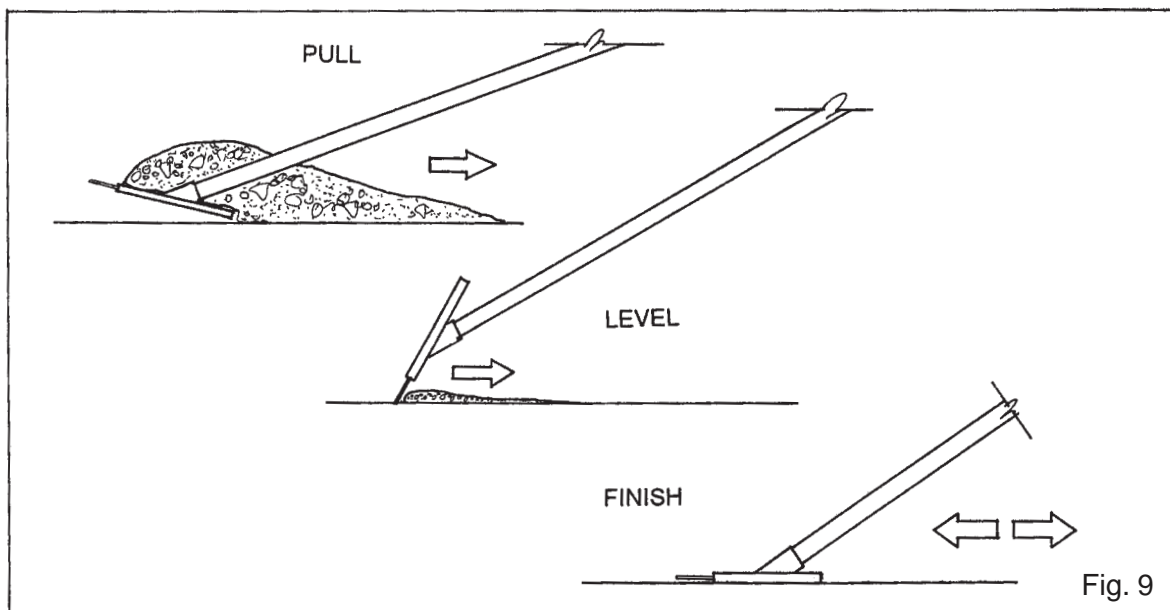

Fig. 9

In all applications we recommend that care be taken when finishing up to an existing bay. Overspilled grout should be removed before set to prevent staining of the adjacent trowel border.

CURING

Natural curing of GRASSCRETE can be described as an inside out process. The former positioned under the slab and around the interstices prevents loss of moisture into the sub-grade.

Surface curing is to some degree dictated by weather conditions. In a sub-tropical climate the use of saturated hessian is one possible method or, in the case of anticipated early rainfall, polythene membranes can be laid.

A further alternative is the use of a water based spray curing agent. This has the advantage of not marking the surface of the concrete during placement. Solvent based curing agents should not be used however due to their flammability.

We would not normally expect to physically cure the concrete for more than 48 hours.

MELTING FORMERS

The term melting is used in this instance rather than burning as the latter can conjure up a misinterpretation of what is actually undertaken.

Assuming the tops of the formers to be free from latent concrete, the melting process is quite simple. To coincide with the operation we recommend that the tops of the formers be pierced with a long steel pin to provide a leading edge for the flame.

The melting operation is ideally carried out using a multi-headed LPG burner (Fig. 10). (These can be purchased from Grass Concrete Limited.)

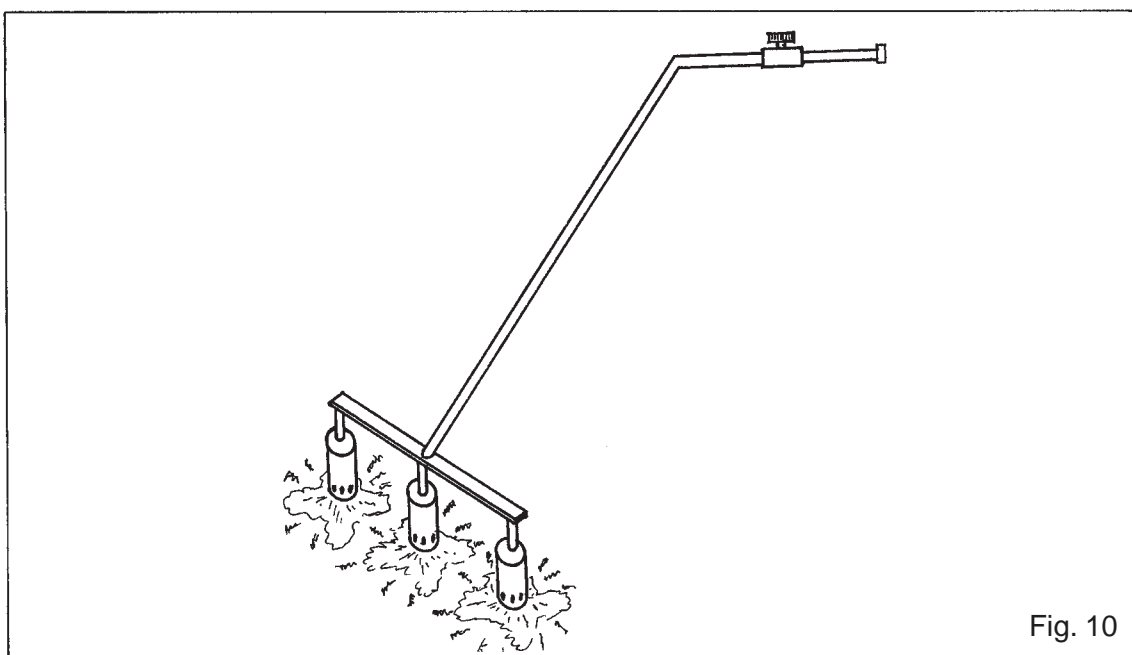

Fig. 10

Melting begins as soon as a flame comes into contact with the former with the top quickly being removed as the molten plastic shrinks down the side walls of the voids. Excessive burning should be avoided as it is not the intention to burn out the whole of the plastic. Indeed, to attempt to do so will damage the integral chair up spacer under the mesh reinforcement. Care should be taken to ensure that the plastic does not block the void in mid-depth particularly on steep slopes where the plastic will naturally fold inwards in to the void. A satisfactorily melted former will show a harmless residue of plastic in the base of the void.

The process of melting does not emit any CFC's, the only emission being a very low amount of CO₂ similar to a wood burning process.

In the interests of safety, we recommend that routine precautions are taken with the positioning of a sand bucket adjacent to the works to eliminate any possible flame spread. It should be pointed out, however, that with the continuous concrete surround to the void, the flame will not spread over the surface.

The melting process can generally be undertaken with one operative working two days in arrears of a casting gang with whom he should keep pace.

TOPSOILING

Unlike precast systems, GRASSCRETE can be topsoiled either during or after the laying process. As the structure places no reliance upon grass for anchorage, the topsoiling and indeed the melting of the formers can be left to a later stage.

In the case of GRASSCRETE used in channel inverts, this means that the surface can be utilised to transport topsoil into place. This offers significant benefits over precast which should not be trafficked until grass is fully established.

Levelling of the topsoil into the pockets can be undertaken by an excavator. Where trafficking the GRASSCRETE it should be by a rubber tyred vehicle. Care should be taken, however, not to drag the excavator bucket along the surface of the concrete as this can damage the concrete ribs.

Fine levelling can then be carried out by hand utilising the same type of squeegee used to pour the concrete.

The topsoil will naturally settle after rainfall and should then be reinstated and seed sown to the recommended rate.

FIRST USE

Where subject to vehicular use, the following empirical rules can be adopted to determine when loading can first take place.

<u>Type</u>	<u>7 days</u>	<u>14 days</u>	<u>28 days</u>
GRASSCRETE GC3:			
A142 mesh	1 tonne	2 tonnes	3.4 tonnes
A193 mesh	1.3 tonnes	2.5 tonnes	4.3 tonnes
GRASSCRETE GC1:			
A193 mesh	2 tonnes	6 tonnes	10 tonnes
A252 mesh	2.7 tonnes	8 tonnes	13.3 tonnes
GRASSCRETE GC2:			
A252 mesh	6 tonnes	20 tonnes	30 tonnes
GRASSCRETE GC2sc			
A393 mesh	8 tonnes	26 tonnes	40 tonnes

GRASS CUTTING

The level upper surface of the GRASSCRETE enables traditional mowing equipment to easily cut and maintain the grass.

We recommend that in waterflow situations due consideration be given to the hydraulic performance of the grass. Immediately prior to rainy seasons the grass is best left with long stems. This enables it to flatten under hydraulic load forming a surface thatch to protect against erosion of the soil infill.

FURTHER INFORMATION

This publication is produced as a generic guide. We realise that individual projects have specific circumstances and we are happy to discuss individual applications with you to evolve a best working practice.

All information in this publication is given in good faith but due to our policy of continuous development is subject to alteration without prior notice.



GrassConcrete

Grass Concrete Limited
Duncan House 142 Thornes Lane Thornes
Wakefield West Yorkshire WF2 7RE
England

Tel: +44(0)1924 379443 Fax: +44(0)1924 290289
E-mail: info@grasscrete.com Web: www.grasscrete.com

The GC Group