

Installation and Servicing

Condensing Boilers/Ultracom hxi

12 hxi G.C.No. 41-019-01

15 hxi G.C.No. 41-019-02

18 hxi G.C.No. 41-019-03

24 hxi G.C.No. 41-019-04

30 hxi G.C.No. 41-019-05

38 hxi G.C.No. 41-019-06

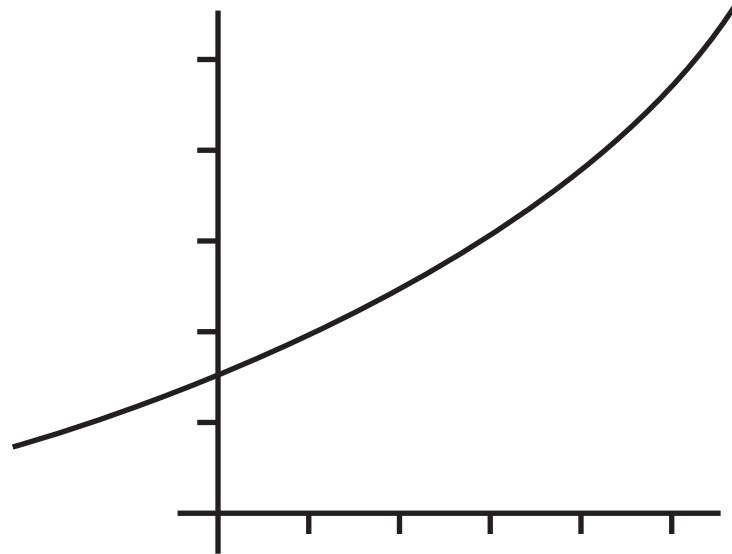

Guarantee Registration

Thank you for installing a new Glow-worm appliance in your home.

Glow-worm appliances are manufactured to the very highest standard so we are pleased to offer our customers a Comprehensive Guarantee.

This product is guaranteed for 24 months from the date of installation or 30 months from the date of manufacture, whichever is the shorter, for parts and labour.

The second year of the parts guarantee, from the beginning of the 13th month onwards after installation or manufacture, is conditional upon the boiler having been serviced by a **competent person** approved at the time by the Health and Safety Executive,

in accordance with the manufacturer's recommendations. We strongly recommend regular servicing of your gas appliance, but where the condition is not met, any chargeable spare parts or components issued within the applicable guarantee period still benefit from a 12 month warranty from the date of issue by the manufacturer.

We recommend you complete and return as soon as possible your guarantee registration card. If your guarantee registration card is missing you can obtain a copy or record your registration by telephoning the Glow-worm Customer Service number 01773 828100.

Customer Service:

01773 828100

Technical Helpline:

01773 828300

General and Sales enquiries:

Tel. 01773 824639

Fax: 01773 820569

To register your Glow-worm appliance call:

0800 0732142

Benchmark places responsibilities on both manufacturers and installers. The purpose is to ensure that customers are provided with the correct equipment for their needs, that it is installed, commissioned and serviced in accordance with the manufacturer's instructions by competent persons and that it meets the requirements of the appropriate Building Regulations. The Benchmark Checklist can be used to demonstrate compliance with Building Regulations and should be provided to the customer for future reference.

Installers are required to carry out installation, commissioning and servicing work in accordance with the Benchmark Code of Practice which is available from the Heating and Hotwater Industry Council who manage and promote the Scheme.

Visit www.centralheating.co.uk for more information.



TABLE OF CONTENTS

These instructions consist of, Installation, Servicing, Fault Finding, Replacement of Parts and Spares. The instructions are an integral part of the appliance and must, to comply with the current issue of the Gas Safety (Installation and Use) Regulations, be handed to the user on completion of the installation.

CONTENTS	DESCRIPTION	SECTION	PAGE
INTRODUCTION	Warnings		4
	Important Information		4
	Statutory Requirements		5
	Boiler Design		6
	Safety Devices		6
	Servicing, Maintenance and Spare Parts		6
	Boiler Specification	1	7
	Boiler Dimensions & Hydraulic Schematic	2	8
	Boiler Location, Clearances and Ventilation	3	9
	Evacuation of Combustion Gas	4	10
Water Systems	5	14	
INSTALLATION	Installation Preparation	6	18
	Boiler Fixing	7	19
	Gas/Water & Condensate Connection	8	20
	Electrical Connection	9	22
	Commissioning	10	23
MAINTENANCE	Servicing	11	27
	Fault Finding	12	31
	Replacement of Parts	13	38
	Spare Parts	14	43
	Manual Handling	15	44
	Declaration of Conformity	-	45
	Commissioning Checklist		46
	Service Interval Record		47

WARNINGS

Gas Leak or Fault

Turn off the gas emergency control valve immediately. Eliminate all sources of ignition, i.e. smoking, blowlamps, hot air guns etc. Do not operate electrical lights or switches either on or off. Open all doors and windows, ventilate the area.

Metal Parts

This boiler contains metal parts (components) and care should be taken when handling and cleaning, with particular regard to edges.

Sealed Components

Under no circumstances must the user interfere with or adjust sealed parts.

Important Information

Gas Category

This boiler is for use only on G20 natural gas, but may be converted for use on G31 gas (Propane L.P.G.).

Gas Safety (Installation and Use) Regulations

In your own interests and that of safety, it is the Law that ALL gas appliances are installed by a **competent person** approved at the time by the Health and Safety Executive and in accordance with the current issue of these regulations.

Control of Substances Hazardous to Health

Under Section 6 of The Health and Safety at Work Act 1974, we are required to provide information on substances hazardous to health.

The adhesives and sealants used in this appliance are cured and give no known hazard in this state.

Insulation Pads

These can cause irritation to skin, eyes and the respiratory tract.

If you have a history of skin complaint you may be susceptible to irritation. High dust levels are usual only if the material is broken.

Normal handling should not cause discomfort, but follow normal good hygiene and wash your hands before eating, drinking or going to the lavatory.

If you do suffer irritation to the eyes or severe irritation to the skin seek medical attention.

Manual Handling

With regards to the "Manual Handling Operations, 1992 Regulations", the appliance exceeds the recommended weight for a one man lift, refer to section 15 for more information.

The handling of the boiler may involve lifting, pushing and pulling, the use of a sack truck may be required.

The following handling techniques and precautions should be considered:

- Grip the boiler at its base
- Be physically capable
- Use safety clothing where appropriate, e.g. gloves, safety footwear.

Ensure safe lifting techniques are used

- Keep back straight.
- Avoid twisting at the waist.
- Avoid upper body/top heavy bending.
- Always grip using the palm of the hand.
- Use designated hand holds.
- Keep load as close to body as possible.
- Always use assistance if required.

Electrical Supply

The boiler MUST be earthed.

All system components shall be of an approved type and all wiring to current I.E.E. wiring regulations.

External wiring must be correctly earthed, polarised and in accordance with the relevant standards.

In GB, this is BS 7671.

In IE, this is the current edition of ETCI rules.

The boiler MUST be connected to a permanent 230V ac, 50Hz supply.

Connection of the whole electrical system of the boiler, including any heating controls, to the electrical supply MUST be through one common isolator and must be fused 3 Amp maximum.

Isolation should be by a double pole switched fused spur box, with a minimum gap of 3mm for both poles. The fused spur box should be readily accessible and preferably adjacent to the appliance. It should be identified as to its use.

Alternatively connection can be made through an unswitched shuttered socket and 3A fused 3-pin plug both to the current issue of BS 1363, provided they are not used in a room containing a bath or shower.

Wiring to the boiler must be PVC 85°C insulated cable, not less than 0.75mm² (24/0.20mm).

Testing and Certification

This boiler is tested and certificated for safety and performance. It is, therefore, important that no alteration is made to the boiler, without permission, in writing, by Glow-worm.

Any alteration not approved by Glow-worm, could invalidate the certification, boiler warranty and may also infringe the current issue of the statutory requirements.

CE Mark

This boiler meets the requirements of Statutory Instrument, No. 3083 The Boiler (Efficiency) Regulations, and therefore is deemed to meet the requirements of Directive 92/42/EEC on the efficiency requirements for new hot water boilers fired with liquid or gaseous fuels.

Type test for purposes of Regulation 5 certified by: Notified body 0087.

Product/production certified by: Notified body 0086.

The CE mark on this appliance shows compliance with:

1. Directive 2009/142/EC on the approximation of the laws of the Member States relating to appliances burning gaseous fuels.
2. Directive 73/23/EEC on the harmonisation of the Laws of the Member States relating to electrical equipment designed for use within certain voltage limits.
3. Directive 89/336/EEC on the approximation of the Laws of the Member States relating to electromagnetic compatibility.

IMPORTANT

Where no British Standards exists, materials and equipment should be fit for their purpose and of suitable quality and workmanship.

The installation of this boiler must be carried out by a **competent person** approved at the time by the Health and Safety Executive and in accordance with the rules in force in the countries of destination.

Manufacturer's instructions must not be taken as overriding statutory requirements.

Statutory Requirements

In GB, the installation of the boiler must comply with the requirements of the current issue of BS6798 and be carried out by a **competent person** approved at the time by the Health and Safety Executive and as described in the following regulations:

The manufacturer's instructions supplied.

The Gas Safety (Installation and Use) Regulations.

The appropriate Buildings Regulations either The Building Regulations, The Building Regulations (Scotland), The Building Regulations (Northern Ireland).

The Water Supply (water fittings) Regulations 1999 and water byelaws 2000, Scotland.

The Health and Safety at Work Act, Control of Substances Hazardous to Health (COSHH).

The Current I.E.E. Wiring Regulations.

Where no specific instructions are given, reference should be made to the relevant British Standard Code of Practice.

In IE, the installation must be carried out by a **competent person** approved at the time by the Health and Safety Executive and installed in accordance with the current edition of I.S.813 "Domestic Gas Installations", the current Building Regulations and reference should be made to the current ETCI rules for Electrical Installation.

GB: the following Codes of Practice apply:

BS4814, BS6798, BS5440 Part 1 and 2, BS5546 Part 1, BS5449, BS6891, BS6700, BS7074 Part 1 and 2, BS7593, BS7671.

IE: I.S.813, BS5546, BS 5449, BS 7074, BS 7593.

NOTE: For further information, see the current issue of the Building Regulations, approved document L1 (in the UK) and the following current issues of:

- 1) Central heating system specification (CheSS) and
- 2) Controls for domestic central heating system and hot water. BRECSU.

Gas Supply

The gas installation must be in accordance with the relevant standards.

In GB, this is BS6891.

In IE, this is the current edition of I.S.813 "Domestic Gas Installations".

The supply from the governed meter must be of adequate size to provide a steady inlet working pressure of 20mbar (8in wg) at the boiler.

On completion, test the gas installation for tightness using the pressure drop method and suitable leak detection fluid, purge in accordance with the above standard.

Domestic Hot Water

All domestic hot water circuits, connections, fittings must be in accordance with the relevant standards and water supply regulations.

GB: Guidance G17 to G24 and recommendation R17 to R24 of the Water Regulations Guide.

IE: The current edition of I.S.813 "Domestic Gas Installations".

Heating System

In GB, it is necessary to comply with the Water Supply (Water Fittings) Regulations 1999 (for Scotland, the Water Byelaws 2000, Scotland).

To comply with the Water regulations your attention is drawn to: The Water Regulations guide published by the Water Regulations Advisory Service (WRAS) gives full details of the requirements.

In IE, the requirements given in the current edition of I.S.813 "Domestic Gas Installations" and the current Building Regulations must be followed.

Boiler Design

Boiler Design

These boilers are designed to provide central heating from a fully pumped open vented or sealed water system and domestic hot water using a fully indirect cylinder. Once the controls are set the boiler operates automatically.

Range Rating

These boilers are fully modulating, it is therefore not necessary to range rate them.,however, if desired, it is possible to range rate the 38hxi max. CH output in 1kW increments, refer to section 10.

Condensate Drain

A plastic drain pipe must be fitted to allow discharge of condensate to a drain. Condensate should, if possible, be discharged into the internal household draining system. If this is not practical, discharge can be made externally into the household drainage system or a purpose designed soak away, see section 8 for more details.

Plumbing from flue terminal

Like all condensing boilers this appliance will produce a plume of condensation from the flue terminal in cool weather. This is due to the high efficiency and hence low flue gas temperature of the boiler. This is normal and not an indication of a fault.

Safety Devices

Electrical Supply Failure

The boiler will not work without an electrical supply. Normal operation of the boiler should resume when the electrical supply is restored. Reset any external controls, to resume normal operation of the central heating. If the boiler does not resume normal operation press the reset button. If the boiler does not resume normal operation after this call your Installation/Service company or Glow-worm service.

Overheating Safety

The boiler software is designed to recognise the potential for an overheat lockout and will shutdown before this happens. To restart the boiler, press the reset button on the controls fascia. If the boiler fails to resume normal operation and all external controls are calling for heat, then call your Installation/Service company or Glow-worm service.

Frost protection

The appliance has a built in frost protection device that protects the boiler from freezing. With the gas and electric supplies ON and irrespective of any room thermostat setting, the frost protection device will operate the pump when the temperature of the boiler water falls below 8°C. A timer is used so that the temperature can be checked periodically. After 10 minutes the pump will be stopped if the temperature is higher than 10°C or has already reached 35°C. The burner will activate if the boiler temperature does not reach 10°C after 30 minutes or at any time if the temperature drops to 5°C. The burner will switch off when the temperature reaches 35°C.

Condensate Drain Blockage

As a safety feature the boiler will stop working if the condensate drain becomes blocked. During freezing conditions this may be due to the forming of ice in the condensate drain external to the house. Release an ice blockage by the use of warm cloths on the pipe. The boiler should then restart.

Servicing, Maintenance and Spare Parts

Servicing and Maintenance

To ensure the continued efficient and safe operation of the boiler it is recommended that it is checked and serviced as necessary at regular intervals. The frequency of servicing will depend upon the particular installation conditions and usage. If this appliance is installed in a rented property there is a duty of care imposed on the owner of the property by the current issue of the Gas Safety (Installation and Use) Regulations, Section 35. Servicing/maintenance should be carried out by a **competent person** approved at the time by the Health and Safety Executive in accordance with the rules in force in the countries of destination. To obtain service, please call your installer or Glow-worm's own service organisation using the telephone number on the inside front cover of this literature.

After servicing, complete the relevant Service Interval Record section of the Benchmark Checklist located on the inside back pages of these instructions.

Spare Parts

Remember, when replacing a part on this appliance, use only spare parts that you can be assured conform to the safety and performance specification that we require. Do not use reconditioned or copy parts that have not been clearly authorised by Glow-worm. If a part is required contact Glow-worm's own service organisation using the telephone number on the inside front cover of this booklet. Please quote the name of the appliance, this information will be on the name badge on the front of the appliance. If in doubt seek advice from the local gas company or Glow-worm's own service organisation using the telephone number on the inside front cover of this booklet.

1 Boiler Specification

13497

BOILER SPECIFICATION	12hxi	15hxi	18hxi
Lift weight	25kg (55lb)	25kg (55lb)	25kg (55lb)
Total weight (installed)	30kg (66lb)	30kg (66lb)	30kg (66lb)
Gas connection	Rc1/2 (1/2in BSPT)	Rc1/2 (1/2in BSPT)	Rc1/2 (1/2in BSPT)
Heating flow and return connection Ø O.D.	22mm. copper	22mm. copper	22mm. copper
Condensate connection Ø I.D.	21.5mm. plastic	21.5mm. plastic	21.5mm. plastic
Water circuit	3 bar (43/5lbf/in ²)	3 bar (43/5lbf/in ²)	3 bar (43/5lbf/in ²)
Electrical supply	230V~50Hz fused 3A	230V~50Hz fused 3A	230V~50Hz fused 3A
Electrical rating	60W fused 3A	60W fused 3A	60W fused 3A
EN60529 IP classification	IPX4D	IPX4D	IPX4D
Internal fuse rating on main PCB	2A	2A	2A
Gas supply (governed meter only) / category	G20 natural gas / II ₂ H ₃ P	G20 natural gas / II ₂ H ₃ P	G20 natural gas / II ₂ H ₃ P
Inlet gas working pressure	20mbar	20mbar	20mbar
Burner % CO ₂ case on	9.3 nominal	9.3 nominal	9.3 nominal
Burner % CO ₂ case off	9.1 nominal	9.1 nominal	9.1 nominal
Approximate max. gas rate after 10 mins. from cold	1.29 m ³ /h 45.6 ft ³ /h	1.61 m ³ /h 57 ft ³ /h	2.00 m ³ /h 70.6 ft ³ /h
Approximate min. gas rate after 10 mins. from cold	0.53 m ³ /h 18.7 ft ³ /h	0.53 m ³ /h 18.7 ft ³ /h	0.53 m ³ /h 18.7 ft ³ /h
Flue type	C ₁₃ , C ₃₃ , C ₄₃	C ₁₃ , C ₃₃ , C ₄₃	C ₁₃ , C ₃₃ , C ₄₃
NOx	Class 5	Class 5	Class 5
Heat output condensing mode	12.9kW	16.2kW	20.02kW
Heat input Nett Q = kW	max. 12.20 min. 5	max. 15.26 min. 5.0	max. 18.9 min. 5
Heat output P = kW	max. 12 min. 4.95	max. 15 min. 4.95	max. 18.57 min. 4.95
SEDBUK rating % 2005	90.5	90.5	90.4
SEDBUK rating % 2009	88.7	88.7	88.6
BOILER SPECIFICATION	24hxi	30hxi	38hxi
Lift weight	28kg (62lb)	28kg (62lb)	28kg (62lb)
Total weight (installed)	33kg (73lb)	33kg (73lb)	33kg (73lb)
Gas connection	Rc1/2 (1/2in BSPT)	Rc1/2 (1/2in BSPT)	Rc1/2 (1/2in BSPT)
Heating flow and return connection Ø O.D.	22mm. copper	22mm. copper	22mm. copper
Condensate connection Ø I.D.	21.5mm. plastic	21.5mm. plastic	21.5mm. plastic
Water circuit	3 bar (43/5lbf/in ²)	3 bar (43/5lbf/in ²)	3 bar (43/5lbf/in ²)
Electrical supply	230V~50Hz fused 3A	230V~50Hz fused 3A	230V~50Hz fused 3A
Electrical rating	60W fused 3A	60W fused 3A	60W fused 3A
EN60529 IP classification	IPX4D	IPX4D	IPX4D
Internal fuse rating on main PCB	2A	2A	2A
Gas supply (governed meter only) / category	G20 natural gas / II ₂ H ₃ P	G20 natural gas / II ₂ H ₃ P	G20 natural gas / II ₂ H ₃ P
Inlet gas working pressure	20mbar	20mbar	20mbar
Burner % CO ₂ case on	9.3 nominal	9.3 nominal	9.0 nominal
Burner % CO ₂ case off	9.1 nominal	9.1 nominal	8.8 nominal
Approximate max. gas rate after 10 mins. from cold	2.58 m ³ /h 91.1 ft ³ /h	3.02 m ³ /h 107 ft ³ /h	4.06 m ³ /h 143 ft ³ /h
Approximate min. gas rate after 10 mins. from cold	0.56 m ³ /h 19.8 ft ³ /h	0.56 m ³ /h 19.8 ft ³ /h	0.67 m ³ /h 23.8 ft ³ /h
Flue type	C ₁₃ , C ₃₃ , C ₄₃	C ₁₃ , C ₃₃ , C ₄₃	C ₁₃ , C ₃₃ , C ₄₃
NOx	Class 5	Class 5	Class 5
Heat output condensing mode	25kW	30.6kW	41kW
Heat input Nett Q = kW	max. 24.4 min. 5.3	max. 28.6 min. 5.3	max. 38.35 min. 6.7
Heat output P = kW	max. 24 min. 5.25	max. 28.2 min. 5.25	max. 38 min. 6.3
SEDBUK rating % 2005	90.5	90.6	90.8
SEDBUK rating % 2009	88.9	88.7	89.2

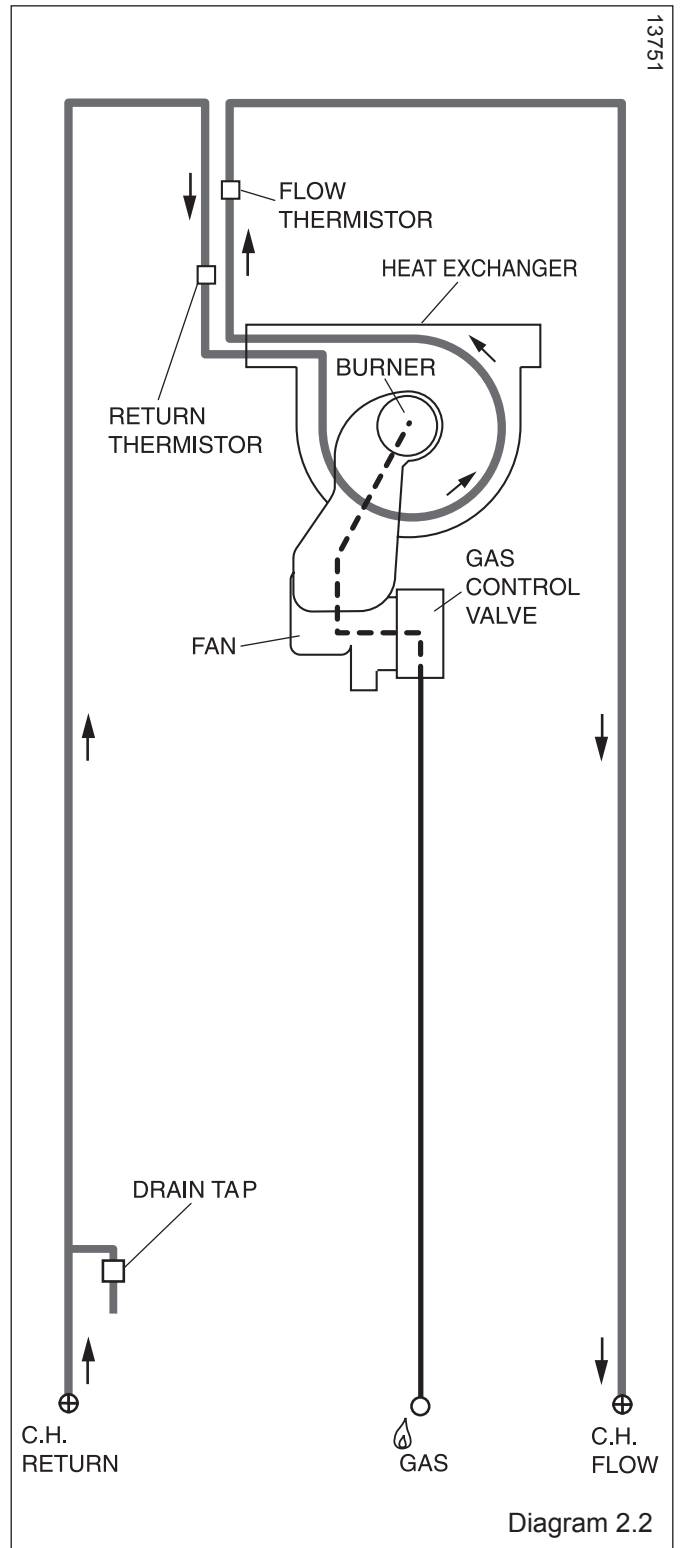
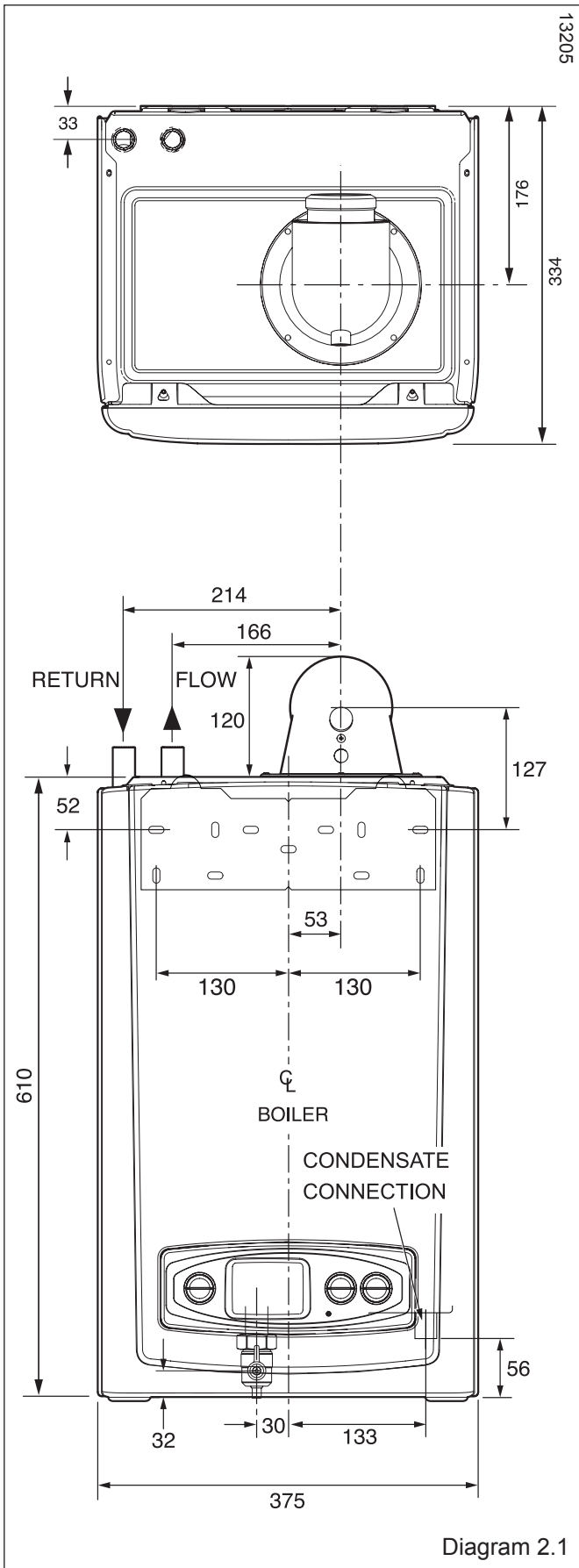

2 Boiler Dimensions & Hydraulic Schematic

All dimensions are given in millimetres (except as noted). The general arrangement of the boiler is shown in diagram 2.1. and the hydraulic and gas schematic, diagram 2.2. The data label is positioned on the front of the inner casing panel.

3 Boiler Location, Clearances and Ventilation

3.1 Location

This boiler is not suitable for outdoor installation. This boiler may be installed in any room, although particular attention is drawn to the installation of a boiler in a room containing a bath or shower where reference must be made to the relevant requirements.

This boiler is suitable for installation in bathroom zones 2 and 3.

In GB this is the current I.E.E. WIRING REGULATIONS and BUILDING REGULATIONS.

In IE reference should be made to the current edition of I.S.813 "Domestic Gas Installations" and the current ETCI rules.

3.2 Clearances

The boiler should be positioned so that at least the minimum operational and servicing clearances are provided, see diagram 3.1.

Additional clearances may be beneficial around the boiler for installation and servicing.

For flue installations where external access is not practicable, consideration should be given for the space required to insert the flue internally, which may necessitate clearance larger than those specified in diagram 3.1.

3.3 Timber Frame Buildings

If the boiler is to be installed in a timber frame building it should be fitted in accordance with the Institute of Gas Engineers document IGE/UP/7/1998. If in doubt seek advice from local gas undertaking or Glow-worm.

3.4 Combustible Material

The boiler and flue are suitable for installation onto and through combustible materials provided that:-

- 1) Minimum 5mm clearance is maintained around the circumference of the flue (air intake).
- 2) The combustible surface and fixings are suitable for supporting the load.
- 3) The minimum clearances from the boiler case are maintained.

3.5 Room Ventilation

The boiler is room sealed so a permanent air vent is not required.

3.6 Cupboard or Compartment Ventilation

Due to the high efficiency and hence low casing temperature of this boiler, cupboard or compartment ventilation is not necessary.

Leave existing air vents.

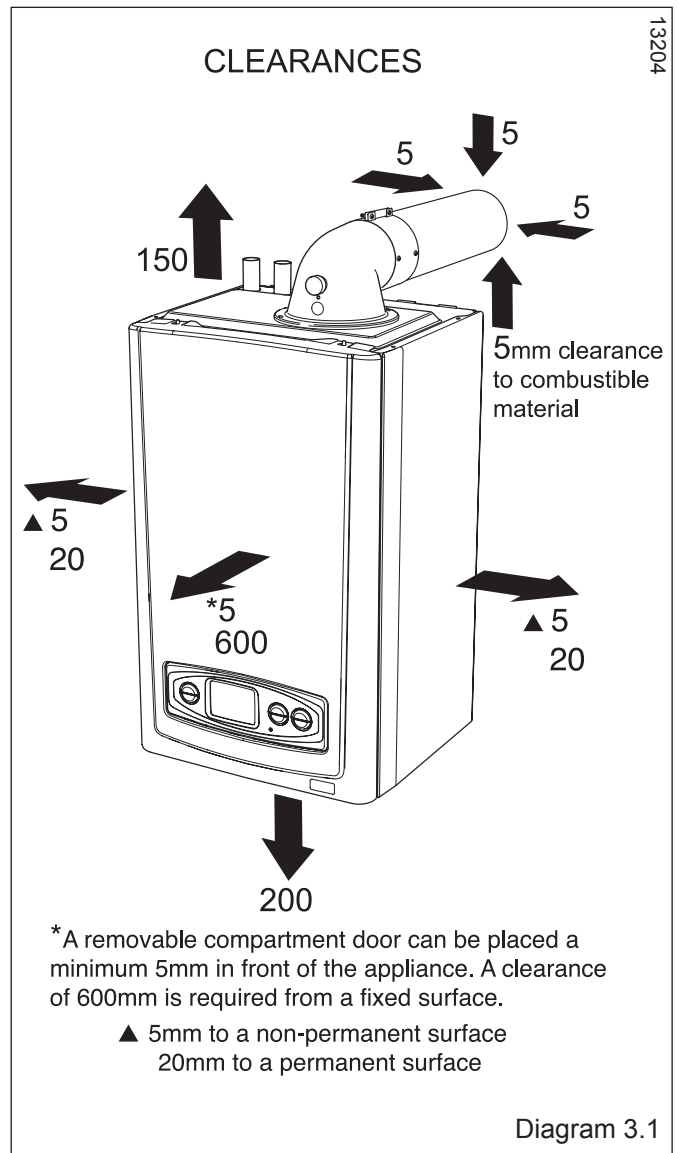

4 Evacuation of combustion Gas

4.1 Regulation



Only flue accessories supplied by Glow-worm must be used.

Different flue outlet configurations can be carried out.

- Consult your supplier for more information about the other possibilities and associated accessories.

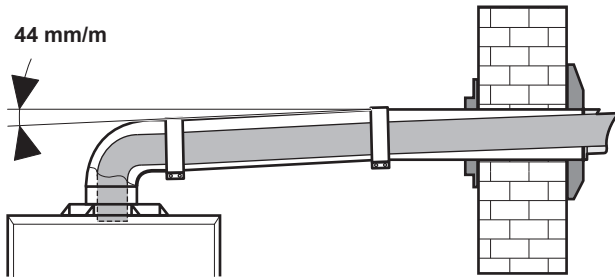

- Standard flue terminal kits have an in-built fall back to the boiler to drain the condensate. These can be fitted level between the appliance and the termination position. All other extended flues must have a fall of at least 44mm/m

The maximum length of the flue outlet is defined according to its type (for example C13).

- Whatever the kind of flue system chosen, observe the minimum distances indicated in the chart below to position the flue terminals.
- To install the flue, refer to the separate flue instruction supplied with your appliance.
- Explain these requirements to the user of the appliance.



If necessary, you must install terminal protection.



Caution! The connection between the flue elbow and the flue outlet must be sealed.

In GB the minimum acceptable siting dimensions for the terminal from obstructions, other terminals and ventilation openings are shown in diagram overleaf.

In IE the minimum distances for flue terminal positioning must be those detailed in I.S.813 "Domestic Gas Installations".

The terminal must be exposed to the external air, allowing free passage of air across it at all times.

Being a condensing boiler some plumbing may occur from the flue outlet. This should be taken into consideration when selecting the position for the terminal.

Carports or similar extensions of a roof only, or a roof and one wall, require special consideration with respect to any openings, doors, vents or windows under the roof. Care is required to protect the roof if made of plastic sheeting. If the carport comprises of a roof and two or more walls, seek advice from the local gas supply company before installing the boiler.



If the flue terminal is positioned near a light source insects may enter the flue system. Where safe and practical to do so advise the homeowner to check the flue outlet and clear visible insects from the terminal end.

H* and J* See diagram 4.2. These dimensions comply with the building regulations, but they may need to be increased to avoid wall staining and nuisance from plumbing depending on site conditions.

Terminal Guard

A terminal guard is required if persons could come into contact with the terminal or the terminal could be subject to damage. If a terminal guard is required, it must be positioned to provide minimum of 50mm clearance from any part of the terminal and be central over the terminal.

The guard should be similar to that shown in diagram 4.1.

A suitable guard is manufactured by: -

Tower Flue Components

Morley Rd.

Tonbridge

Kent TN9 1RA.

Size: 280mm x 165mm. Part No: CGDK3

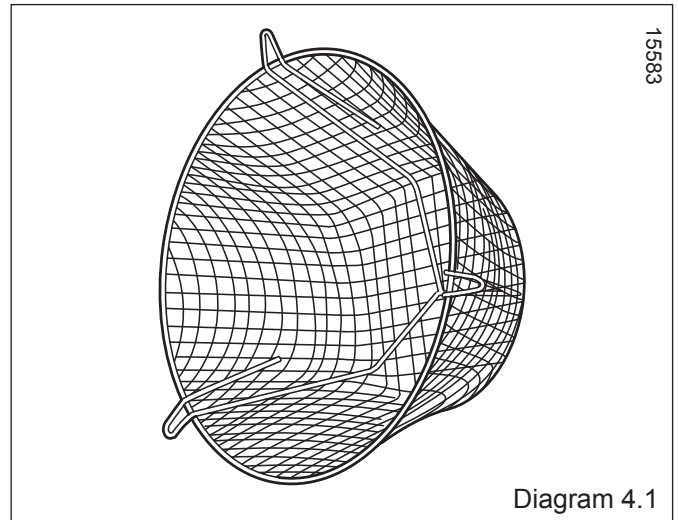
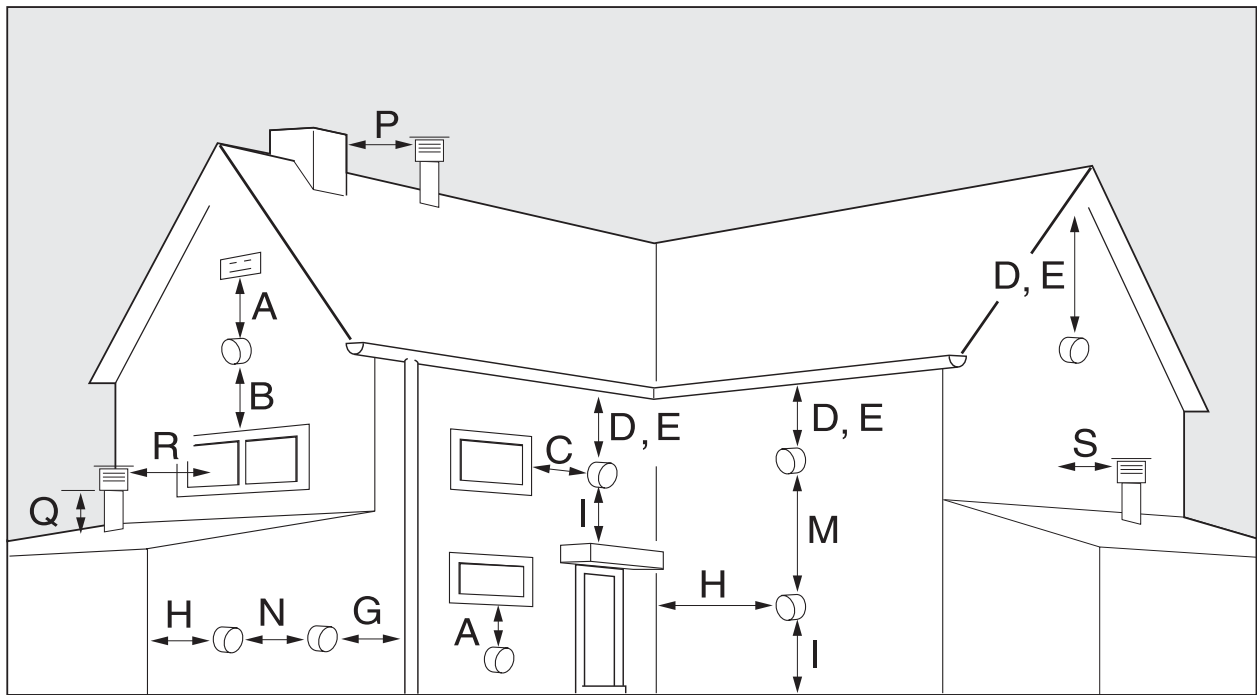

Diagram 4.1



UNDER CAR PORT etc.

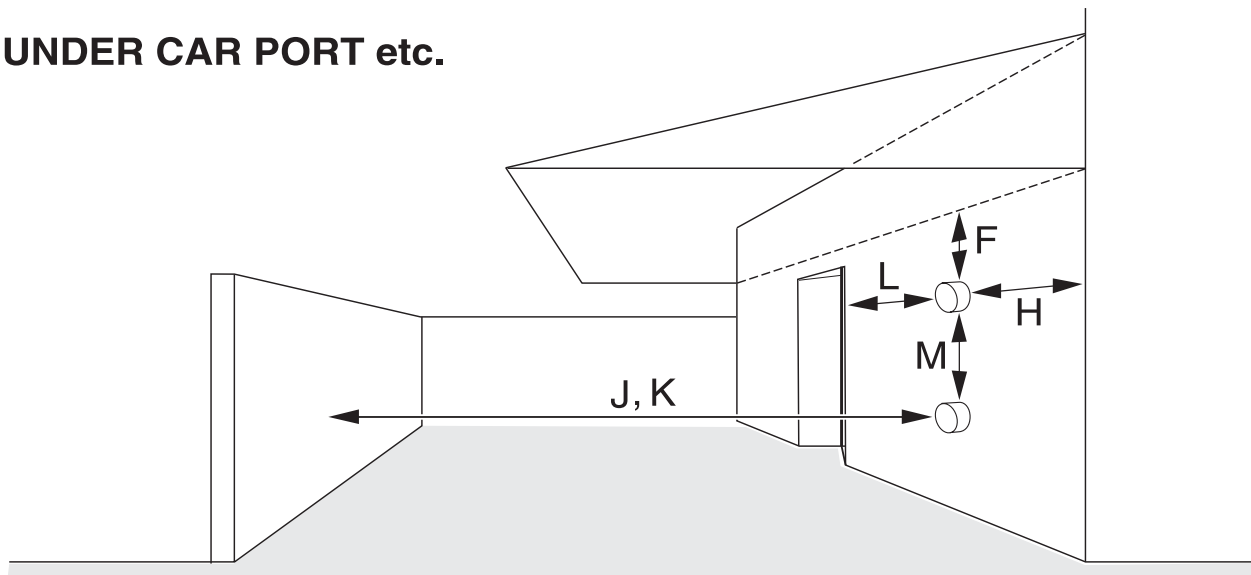

Diagram 4.2

Position	Position of the flue terminal	mm
Horizontal flues		
A	directly below an opening, air brick, opening windows	300
B	above an opening, air brick, opening windows	300
C	horizontally to an opening, air brick, opening windows	300
D	below gutter, drain/soil pipe	25
E	below eaves	25 ⁽¹⁾
F	below a balcony or car port	25
G	from vertical drain pipes and soil pipes	25
H	from internal/external corners	25
H ⁽²⁾	to a boundary alongside the terminal	300
I	above adjacent ground or balcony level	300
J ⁽²⁾	from surface or a boundary facing the terminal	600

Position	Position of the flue terminal	mm
L	from opening (door/window) in car port into dwelling	1200
M	vertical from a terminal	1500
N	horizontally from a terminal	300
Vertical flues		
P	from another terminal	600
Q	above roof level	300
R	from adjacent opening window	1000
S	from adjacent wall to flue	300

(1) There should be no ventilation/opening in the eaves within 300mm distance of the terminal.

(2) These dimensions comply with the building regulations, but they may need to be increased to avoid wall staining and nuisance from plumbing depending on site conditions.

4.2 Flue configuration description

4.2.1 Horizontal concentric flue Ø 60/100 mm or Ø 80/125 mm (C13 type installation)



If the terminal is at less than 1.80 m from the ground, you must install a terminal protection kit.

Ø 60/100 mm

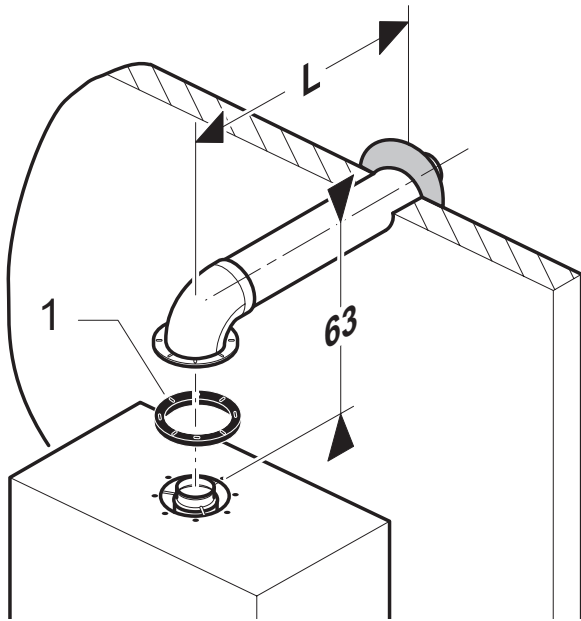

Key
1 Gasket (fitted)

Ø 80/125 mm

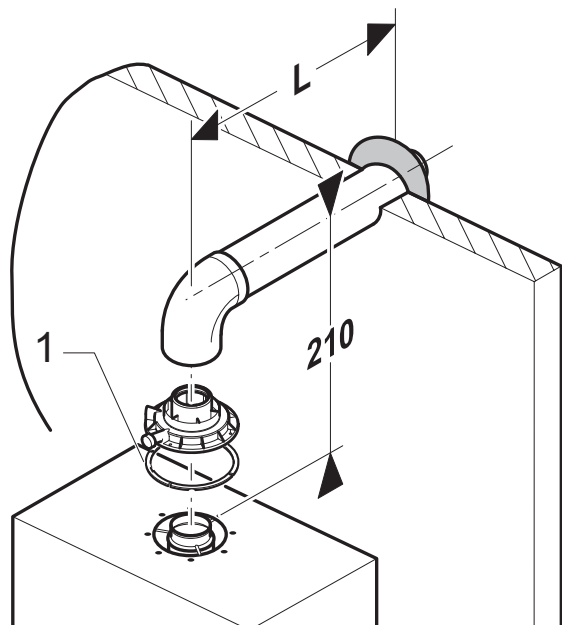

Key
1 Gasket (fitted)

Type	Max length
Ø 60/100	10 m
Ø 80/125	25 m

Each time an additional 90° bend is necessary (or 2 at 45°), the length (L) must be reduced by 1 m.

4.2.2 Vertical concentric flue Ø 60/100 mm or Ø 80/125 mm (C33 type installation)



If the terminal is at less than 1.80 m from the ground, you must install a terminal protection kit.

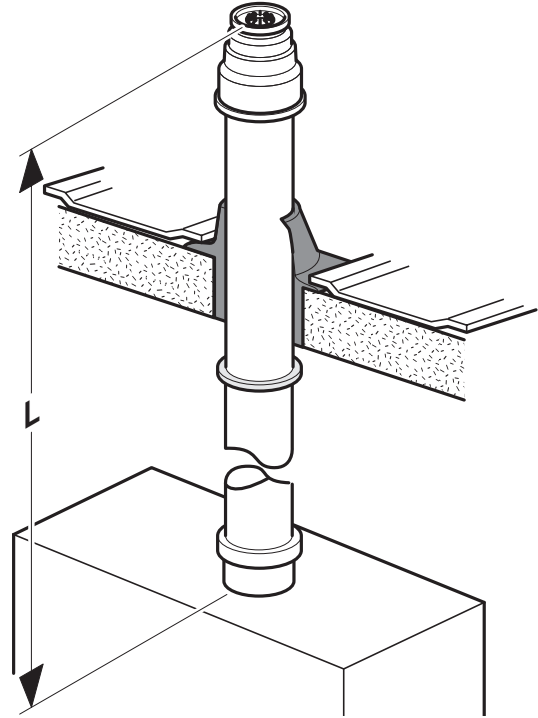

Type	Max length (L)
Ø 60/100	10 m
Ø 80/125	25 m

Each time an additional 90° bend is necessary (or 2 at 45°), the length (L) must be reduced by 1 m.

**4.2.3 Multiple boiler chimney flue
Ø 60/100 mm (C43 type installation)**



The flue connecting from the appliance to the flue system must be supplied from the manufacturer of the boiler.



C43 flue systems must not be a 'pressurised system' but act under natural draught principles



C43 type flue systems must have their own condensate drain fitted and not allow condensate to mix into other appliances

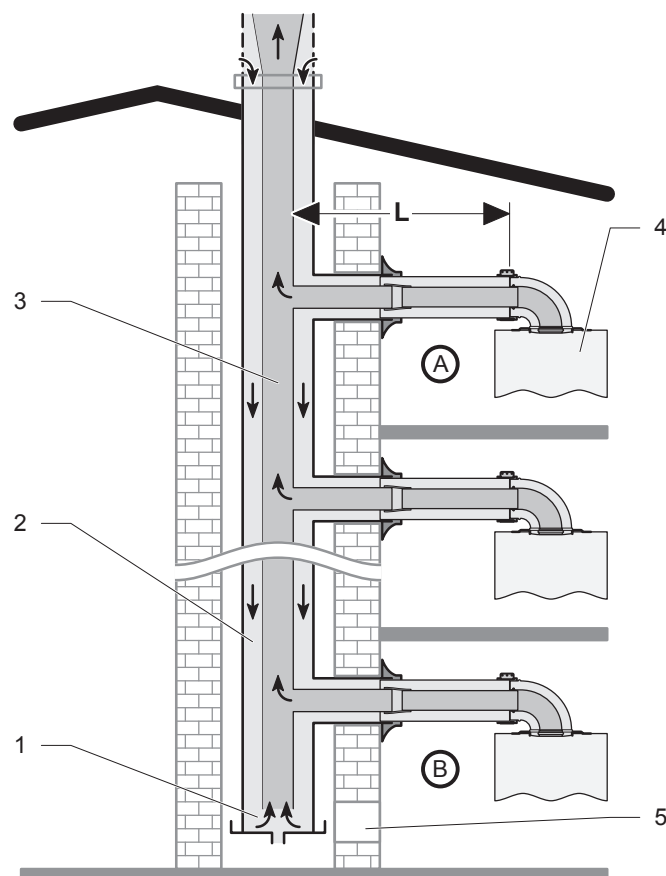

- Key**
- 1 Pressure balancing system
 - 2 Air-inlet pipe
 - 3 Collector pipe
 - 4 Boiler
 - 5 Inspection hatch
 - A Final storey
 - B Ground floor

Type	Max length (L)
Ø 60/100	10 m

Each time an additional 90° bend is necessary (or 2 at 45°), the length (L) must be reduced by 1 m.

Multiple Boiler Chimney Flue Length

The flue length must be calculated and installed according to the relevant standards EN 13384-1 and 2 (C43 flue systems only) with reference to the table below and the manufacturers instructions supplied.

The appliance maximum flue length must be included when calculating the overall design of the flue system.

NOTE: The horizontal flue terminal must be removed.

MODEL	Ultracom 12hxi	Ultracom 15hxi	Ultracom 18hxi	Ultracom 24hxi	Ultracom 30hxi	Ultracom 38hxi
Exhaust mass rate (g/s)						
At Min Thermal Load (40C°/30°C)	2.30	2.30	2.30	2.45	2.45	3.10
At Max Thermal Load (80C°/60°C)	5.65	7.10	8.75	11.30	13.25	18.30
Exhaust temperature (°C)						
At Min Thermal Load (40C°/30°C)	56.0	56.0	56.0	44.0	44.0	46.0
At Max Thermal Load (80C°/60°C)	69.0	70.0	69.0	66.0	57.0	73.0

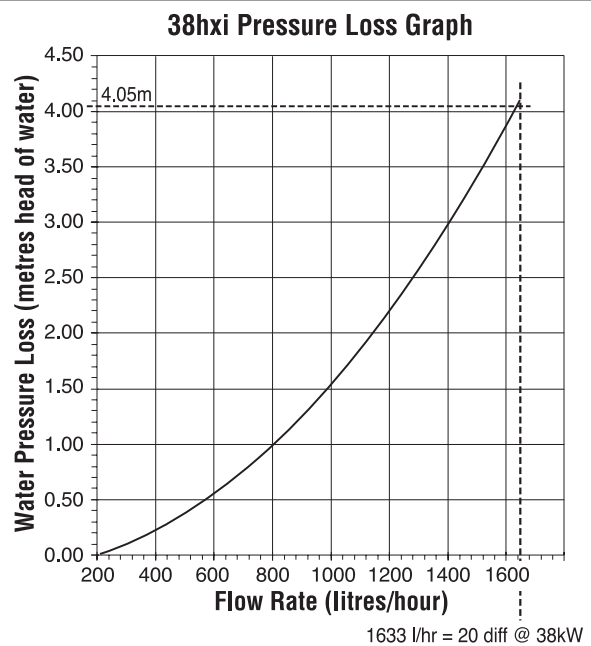
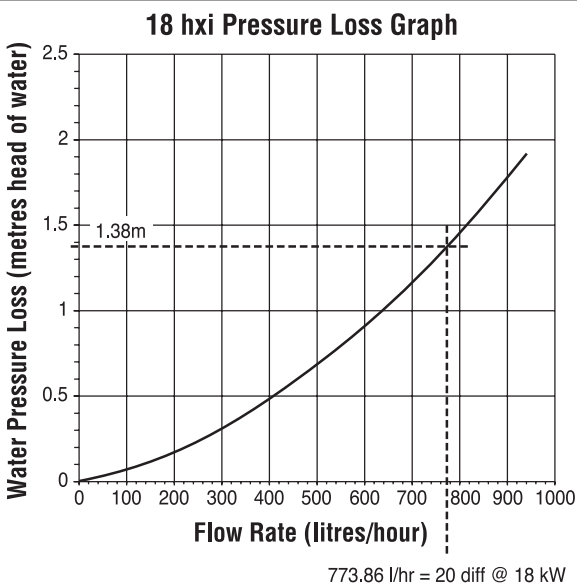
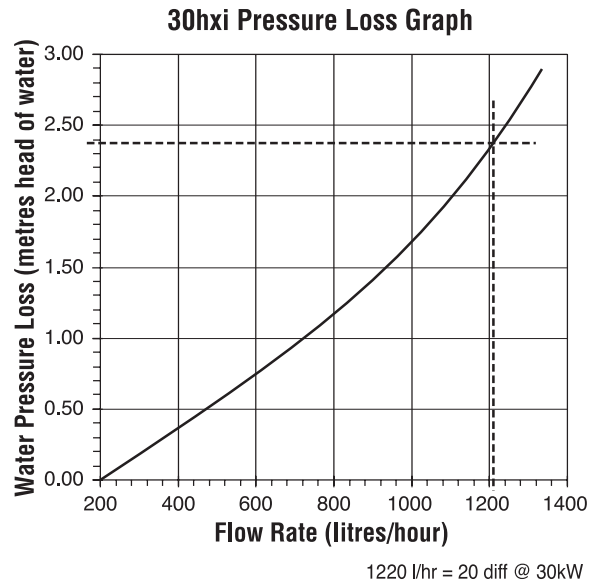
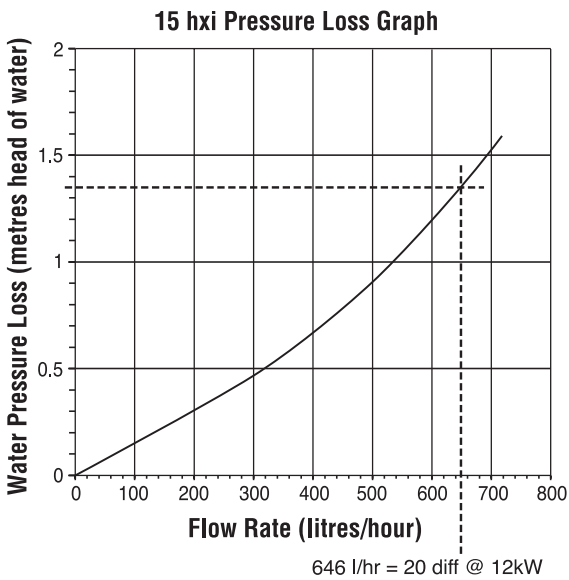
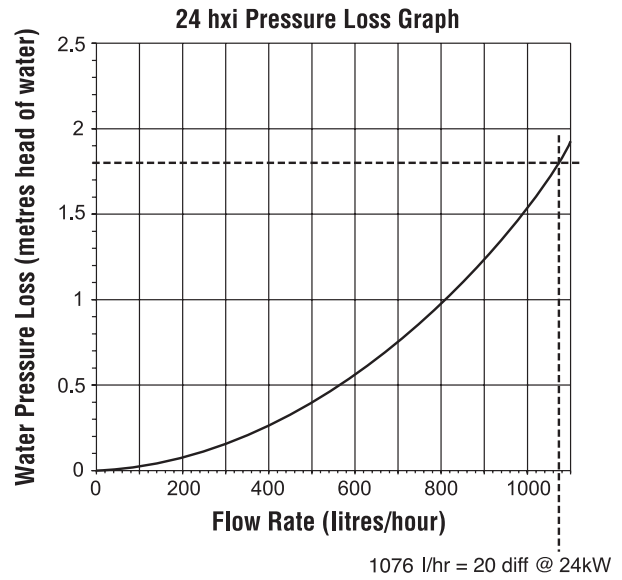
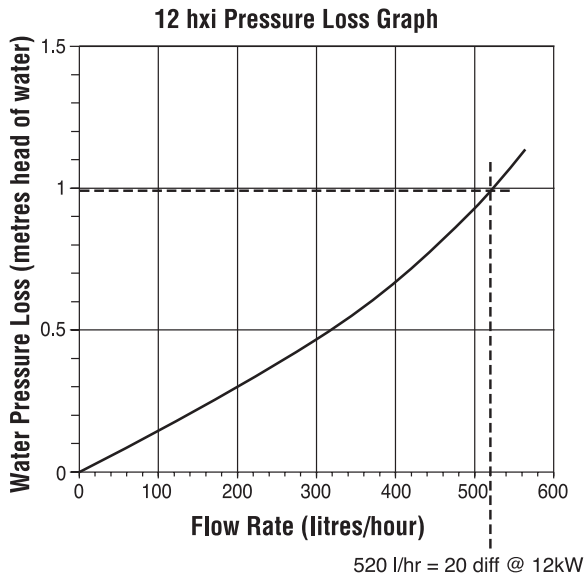

Diagram 5.1

5 Water Systems - General

5.1 General

This boiler is designed to provide central heating from a fully pumped open vented or sealed water system and domestic hot water using a fully indirect vented or unvented cylinder.

An options board accessory is available to activate and link the internal programmer with a Honeywell S or Y plan system.

Domestic Hot Water Cylinder

SINGLE FEED INDIRECT CYLINDERS ARE NOT SUITABLE.

The domestic hot water cylinder must be of the double feed fully indirect coil type.

Draining Points

Draining taps must be provided at all low points of the system, which will allow the entire system to be drained.

Draining taps shall be to the current issue of BS2879.

5.2 Pump

The pump should be fitted on the flow pipe from the boiler and have isolating valves each side.

A variable duty pump should be set to give a temperature difference of no greater than 20°C between the flow and return, with the thermostat set at "MAX", which is about 80°C, to give a flow rate as given in the table.

See chart for pressure loss of the boiler, diagram 5.1.

High resistance microbore systems may require a higher duty pump.

5.3 Flow Rate

If it is necessary to alter the flow rate, the system can be fitted with a lockable balancing valve in the main flow or return pipes shown as valve "A" in diagram 5.3. The flow rate through the boiler must not be allowed to fall below that given in diagram 5.1.

5.4 Bypass

A system bypass 'B' will be required fitted at least 1.5 metres away from the boiler, refer to the current issue of the central heating system specifications (CHeSS).

5.5 Water Treatment

Existing system- It is ESSENTIAL that prior to installing the new boiler the system is thoroughly flushed.

New system- For optimum performance after installation, the boiler and its associated central heating system should also be flushed.

Flushing should be carried out in accordance with BS7593: 2006 using a cleanser such as Sentinel X300 or X400, Fernox Restorer or Salamander corrosion guard cleaner.

IMPORTANT: Ensure all cleanser is removed from the whole system before adding an inhibitor.

For long-term corrosion protection, after flushing, an inhibitor suitable for stainless steel exchangers should be used, refer to the current issue of BS 5449 and BS 7593 on the use of inhibitors in central heating systems. Examples are Sentinel X100 Fernox Protector or Salamander corrosion guard inhibitor.

Water Systems - Domestic Hot Water

5.6 Unvented DHW System

General - All domestic hot water circuits, connections, fittings must be in accordance with the relevant standards and water supply regulations.

For GB: Guidance G17 to G24 and recommendation R17 to R24 of the Water Regulations Guide (for Scotland, the Water Byelaws 2000, Scotland).

Document G Sanitation, hot water safety and water efficiency, section 3 of the building regulations, requires that the installation of an unvented system should be notified to the local authority Building Controls Department and that the work must be carried out by a competent person approved at the time by the Health and Safety Executive, as defined in the approved document G3.

For IE: The current edition of I.S.813 "Domestic Gas Installations".

Where a storage system will not have a vent to atmosphere the installation must comply with the building regulations and the Water Supply (water fittings) regulations 1999 and water byelaws 2000, Scotland, see also the current issue of BS5546 and BS6700.

If fitting to an existing system the local authority should be informed.

5.7 Vented DHW System

General - All domestic hot water circuits, connections, fittings must be in accordance with the relevant standards and water supply regulations.

For GB: Guidance G17 to G24 and recommendation R17 to R24 of the Water Regulations Guide (for Scotland, the Water Byelaws 2000, Scotland).

For IE: The current edition of I.S.813 "Domestic Gas Installations".

Water System - Open (Vented) Central Heating System

The boiler must be supplied from an unrestricted water supply taken from a feed and expansion cistern situated at a maximum height of 27 metres (90ft) above the boiler. The cold feed must be 15mm minimum size.

The vent must rise continuously and be unrestricted.

It is important that the relative positions of the pump, cold feed and open vent are as shown in diagram 5.2.

5.9 Combined Feed and Vent

For combined feed and vent, a 22mm pipe must be fitted in accordance with BS 5449.

5.10 Sealed water Systems

The installation must comply with the appropriate requirements of the current issue of BS4814, BS5449, BS6759, BS6798 and BS7074 Part 1 and 2. See diagram 5.3 for a suggested layout.

5.11 Safety Valve

A safety valve must be fitted to a sealed system. It shall be preset, non-adjustable with a lift pressure of 3 bar, incorporating seating of a resilient material, a test device and a connection for drain.

The drain from the safety valve must be routed outside the building, must not discharge above an entrance or window or any type of public access area, be clear of any electrical fittings and positioned so that any discharge can be seen.

5.12 Expansion Vessel

A diaphragm type expansion vessel, conforming to the current issue of BS4814 (see also BS7074 Part 1 and 2) must be connected at a point close to the inlet side of the circulating pump, see the diagrammatic layout, diagram 5.3 unless laid down differently by the manufacturer.

The expansion vessel volume depends on the total water system volume and the initial system design pressure. For any system an accurate calculation of vessel size is given in the current issue of BS5449 and BS7074 Part 1.

Example: For an initial design pressure of 0.7 bar, the minimum total vessel volume required is 0.063 x Total System Volume.

NOTE: A higher initial design pressure requires a larger volume expansion vessel.

In GB, guidance on vessel sizing is also given in the current issue of BS5449 and BS7074 Part 1.

In IE refer to the current edition of I.S.813 "Domestic Gas Installations".

The charge pressure must not be less than the static head of the system, that is, the height of the highest point of the system above the expansion vessel.

5.13 Pressure Gauge

A pressure gauge with a set pointer and covering at least 0 to 4 bar (0 to 60 lb/in²) shall be fitted permanently to the system in a position where it can be seen when filling the system.

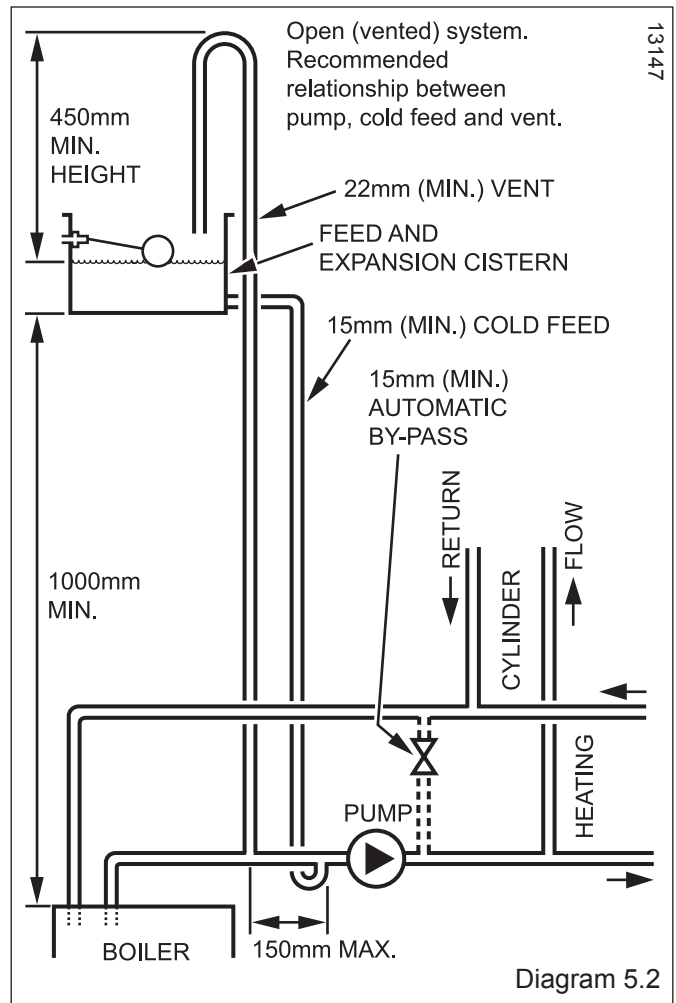

5.14 Water Makeup

Provision should be made for replacing water loss from the system using a make up bottle mounted in a position higher than the top point of the system, connected through a non-return valve to the return side of either the heating circuit or the hot water cylinder. Alternatively, provision for make up can be made using a filling loop.

5.15 Filling a Sealed Water System

Provision for filling the system at low level must be made, see diagram 5.4. There must be no permanent connection to the mains water supply, even through a non-return valve.

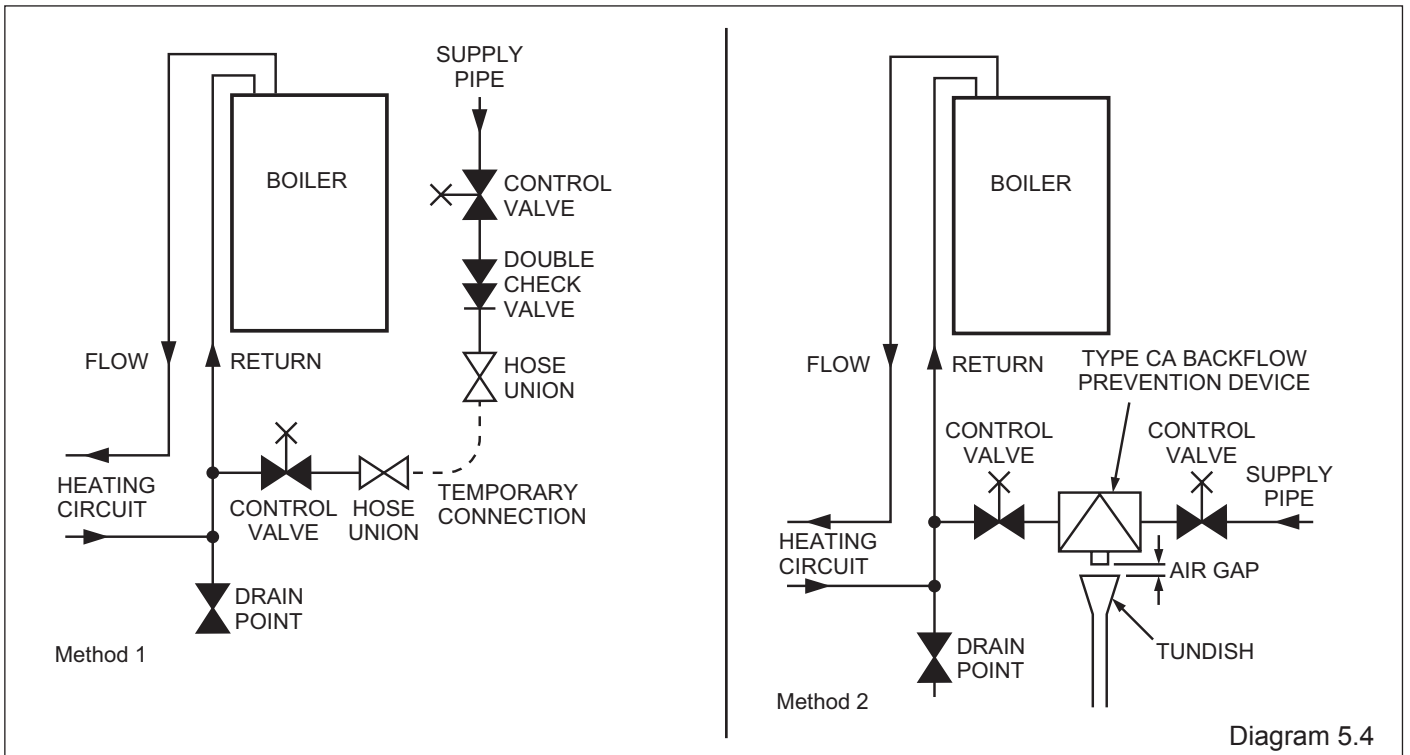
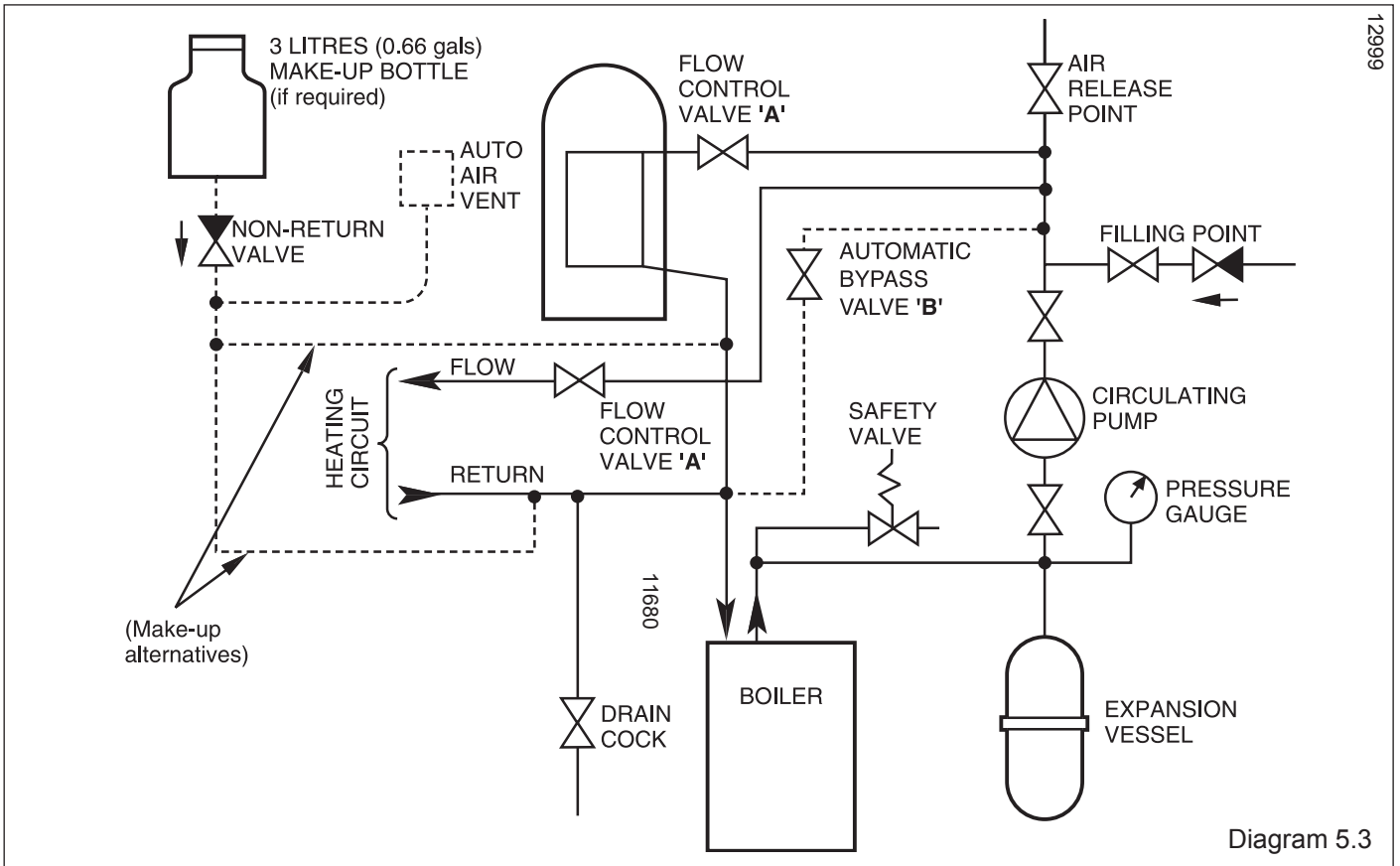

6 Installation Preparation

6.1 Appliance Pack

The top polystyrene pack contains all the items illustrated in diagram 6.1.
Remove the carton sleeve and top pack then lift the boiler and its polystyrene base support out of the lower pack.

6.2 Site Requirements

The boiler mounting wall should be suitable for the weight of the appliance and be true and flat.

NOTE: Due to the varied site conditions we do not supply fixings and advise that the installer should supply those which are suitable.

6.3 Wall Template

Take the wall template from the document pack and place in the desired position on the wall, giving due consideration to the required boiler clearances and the flue you are fitting. Mark the position of the flue centre, if fitting a side flue, extend the flue centre line into the corner then 176mm along the adjacent wall, see diagram 6.2.

For extended side flues, the flue hole centre should be determined by extending the dashed inclined line on the template to the side wall. This dashed line is drawn at 44mm/metre (2.5°) rise from the boiler. Where this line reaches the side wall, a horizontal line should be marked. The vertical centre line of the flue should then be marked at 176mm from the back wall.

To allow for the flue passing through the wall at this angle a 125mm hole should be drilled irrespective of internal or external installation.

Remove the wall template.

6.4 Flue Hole Cutting

External access flue installation can use a 105mm diameter core drill.

Internal access only flue installation will need a 125mm diameter core drill.

NOTE: The flue is designed with an internal fall of 44mm/metre (2.5°), therefore the hole can be drilled horizontally. If flue extension pipes are to be used then a core drill size of 125mm is required. This will allow the extension pieces to slope at 44mm/metre (2.5°) towards the boiler.

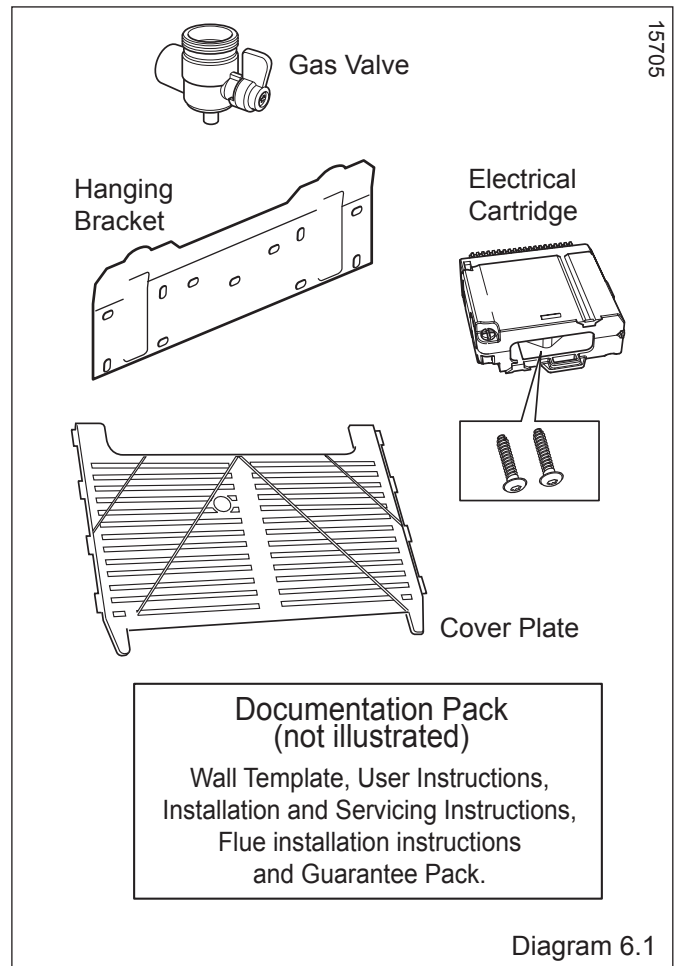

Diagram 6.1

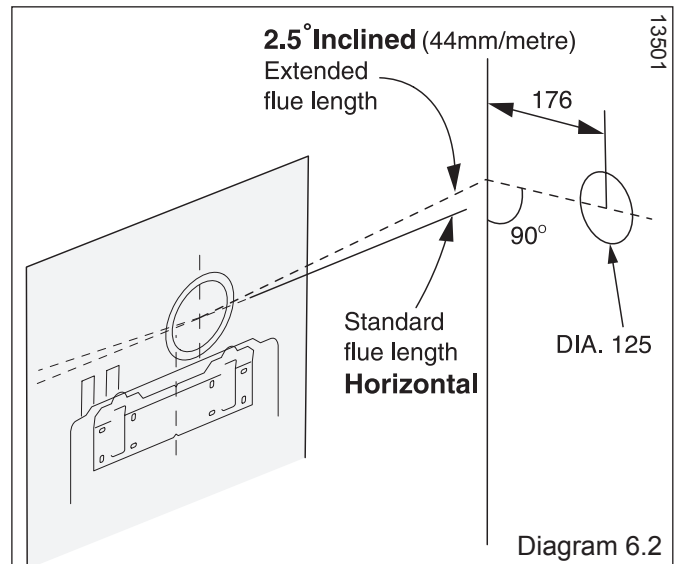

Diagram 6.2

7 Boiler Fixing

7.1 Hanging Bracket Fixing

Reposition the wall template over the flue hole and mark the position of the fixing holes for the hanging bracket, see diagram 7.1.

Mark and drill the fixing holes and secure the hanging bracket which is supplied in the polystyrene base pack.

NOTE: Due to the varied site conditions we do not supply fixings and advise that the installer should supply those which are suitable.

7.2 Boiler Hanging

IMPORTANT: With regards to the Manual Handling Operations, 1992 Regulations, the following lift operation exceeds the recommended weight for a one man lift, refer to section 15 Manual Handling.

Lifting the boiler into position, lean the top of the boiler slightly to the wall and position just above the hanging bracket. Lower the boiler slowly and engage onto the hanging bracket, see diagram 7.2.

Remove the polystyrene base support.

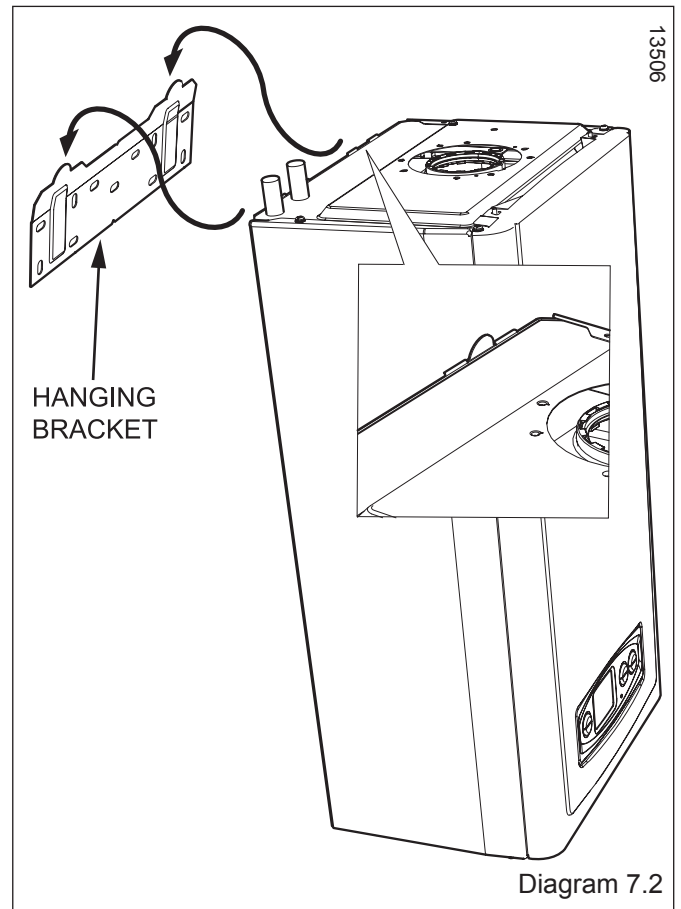
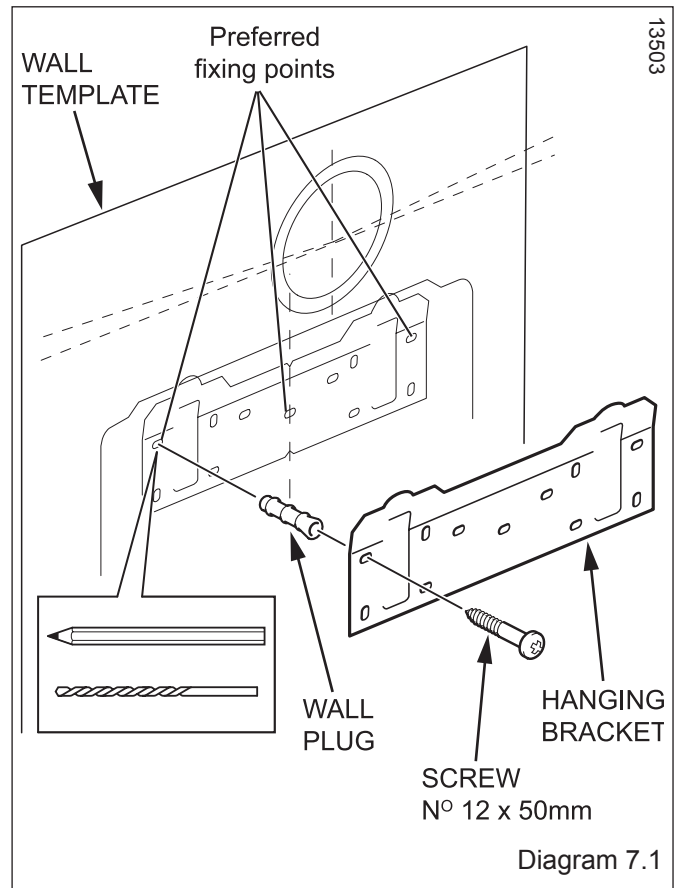

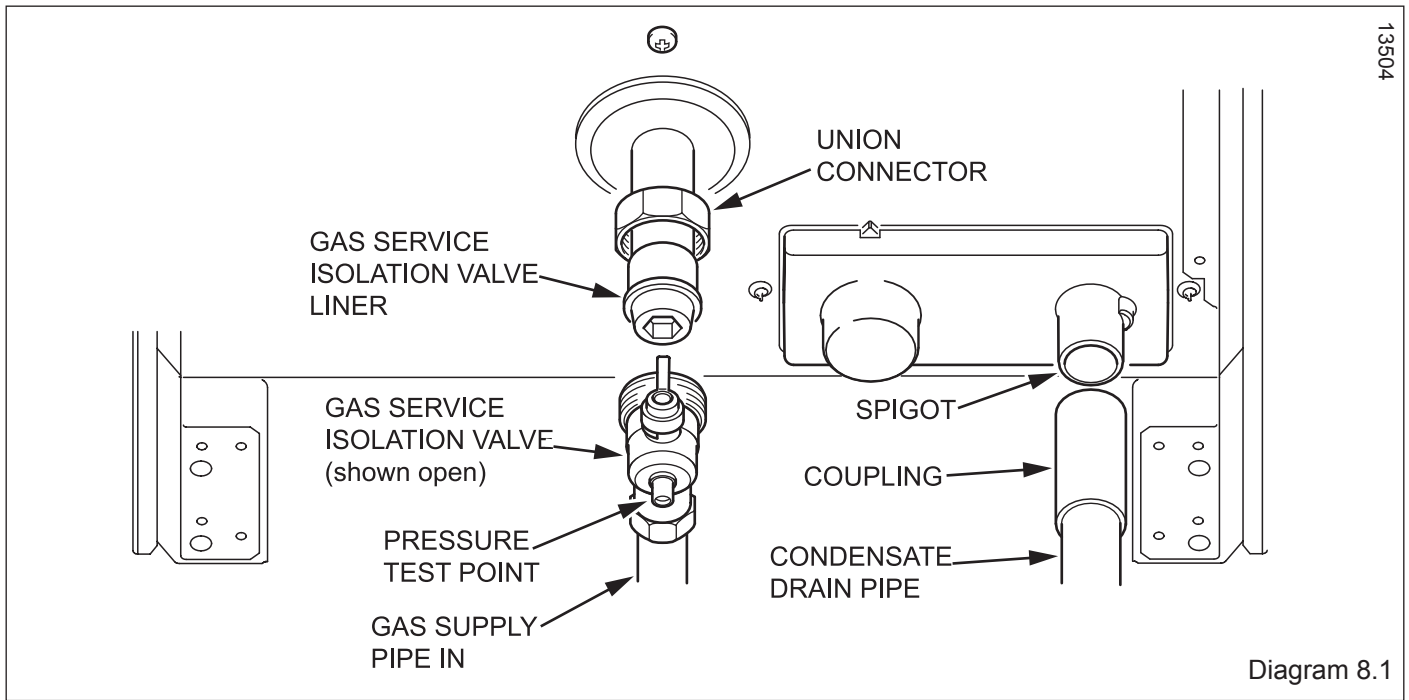

Diagram 8.1

Gas/Water & Condensate Connection

8.1 Gas Connection

Before connection check the supply of local gas. Refer to diagram 8.1, the gas supply can be connected from below or through the wall at the rear of the boiler. The whole of the gas installation, including the meter, should be inspected, tested for tightness and purged in accordance with the current issue of BS6891 and in IE the current edition of I.S.813 "Domestic Gas Installations".

8.2 Water Connections

Provision is made for the water connections to be made from above the boiler, see diagram 8.2. Flush out the heating systems before connecting to the boiler, refer to section 5.

8.3 Condensate Trap and Siphonic Drain Connection

The condensate drain, see diagram 8.1, is suitable for use with standard "Push fit" overflow pipe and couplings. DO NOT use adhesive when connecting to the spigot. The drain pipe should be non corrosive plastic.

IMPORTANT: Please remove spigot bung before fitting condensate drain connection.

The condensate drain pipe should have a fall of at least 2.5° 44mm/metre away from the boiler and if possible be discharged into the household internal drainage system. If this is not practicable, discharge can be allowed into the external household drains or a purpose designed soak away, refer to diagram 8.3.

It is recommended that any external condensate drain pipe is protected and also preferably of 32mm diameter, to prevent

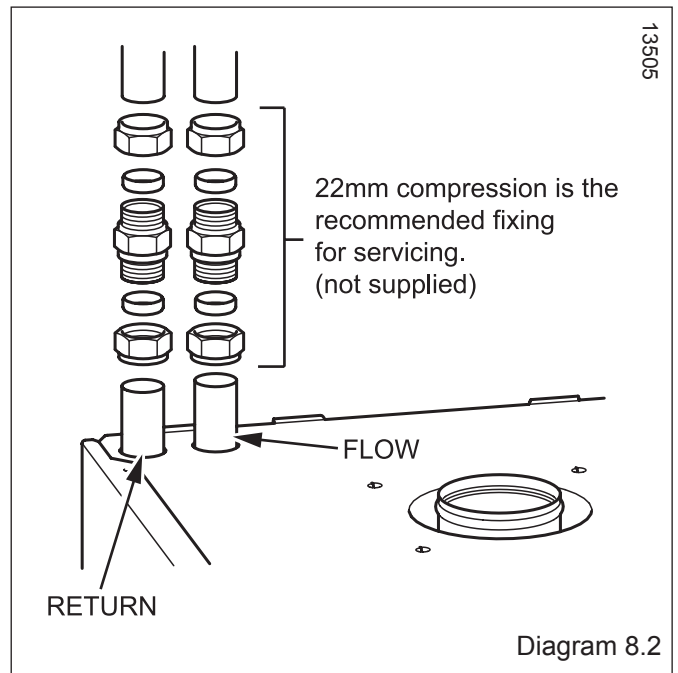

Diagram 8.2

freezing in adverse weather conditions.

The condensate is discharged periodically in 'slugs' by siphonic action.

It is not necessary to provide air breaks or extra traps in the discharge pipe as there is already a 75mm high trap inside the boiler. Fitting an extra trap may cause the boiler siphon to work incorrectly.

Refer to BS5546 or BS6798 for advice on disposal of boiler condensate.

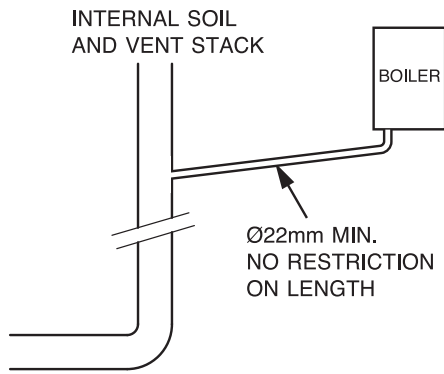

Internal Soil and Vent Pipe

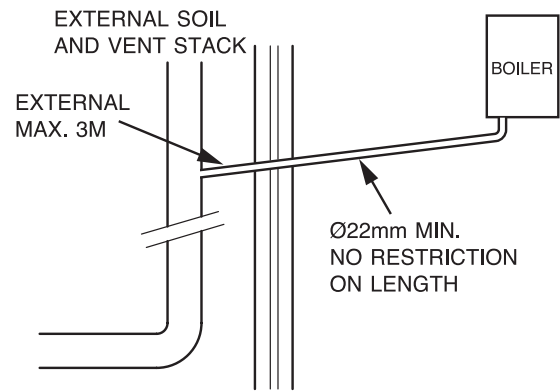

External Soil and Vent Pipe or Rainwater Pipe

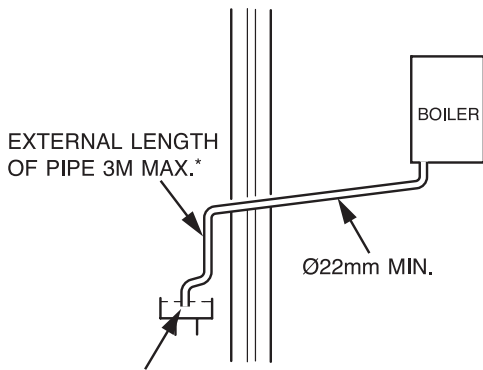

OPEN END OF PIPE DIRECT INTO GULLEY BELOW GROUND BUT ABOVE WATER LEVEL

*NOTE: FOR EXTENDED PIPE RUNS 32mm DIA. PIPE SHOULD BE USED.

External Termination to a Gully or Hopper

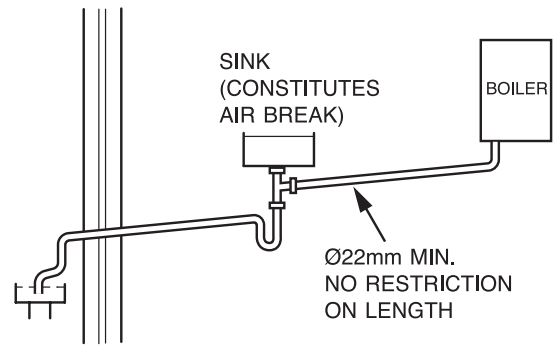

Internal Termination into Combined Sink Waste

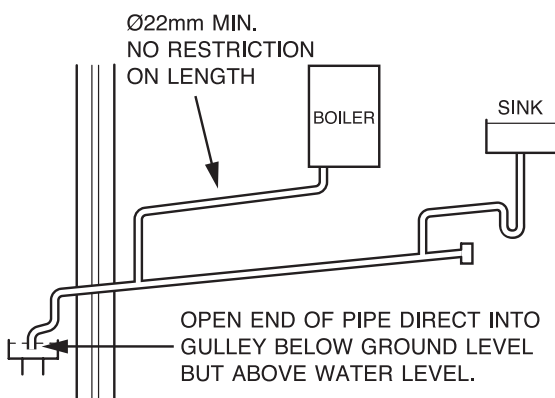

Internal Termination Downstream of Sink Waste

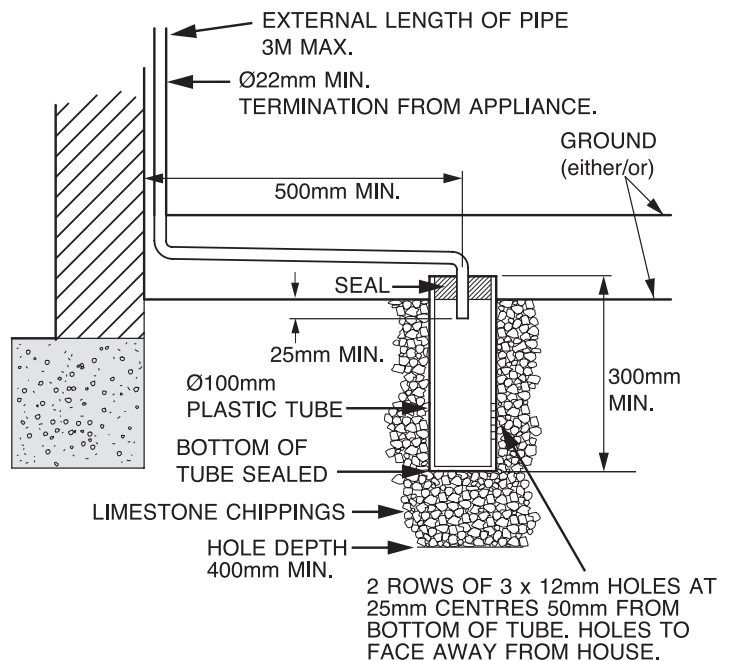

External Termination into Soakaway

NOTE: PIPEWORK SHOULD ALWAYS FALL AWAY FROM BOILER BY AT LEAST 2.5° 44mm FOR EVERY 1M.

Diagram 8.3

Electrical Connection

WARNING: This appliance must be earthed.

- This appliance must be wired in accordance with these instructions. Any fault arising from incorrect wiring cannot be put right under the terms of the Glow-worm guarantee.
- All system components must be of an approved type. Electrical components have been tested to meet the equivalent requirements of the BEAB.
- Do not interrupt the mains supply with a time switch or programmer.
- Connection of the whole electrical system and any heating system controls to the electrical supply must be through a common isolator.
- Isolation should preferably be by a double pole switched fused spur box having a minimum contact separation of 3mm on each pole. The fused spur box should be readily accessible and preferably adjacent to the boiler. It should be identified as to its use.
- A fused three pin plug and shuttered socket outlet may be used instead of a fused spur box provided that it is not used in a room containing a fixed bath or shower.
- The boiler is suitable for installation in bathroom zones 2 and 3.

9.1 Electrical Wiring

Remove the electrical cartridge from the fittings pack.

Remove the securing screw to open the cartridge, see diagram 9.1.

NOTE: There are two screws supplied loose in the electrical cartridge, these will be required to secure the cartridge into the electrical interface housing.

Slacken the cable strain relief screws in the electrical cartridge, see diagram 9.1.

Route the mains supply and system cables through the strain relief and connect to the relevant plug, see diagram 9.2.

9.2 Pump Wiring

Ensure that a separate pump supply cable is routed through the strain relief and connected to the relevant plug, see diagram 9.2.

Slacken the cable strain relief and route the pump electrical supply cable and connect as shown in diagrams 9.1 and 9.2.

9.3 System Controls

If you are fitting the Glow-worm Options Board Kit, please refer to the instructions supplied with the kit for the system wiring.

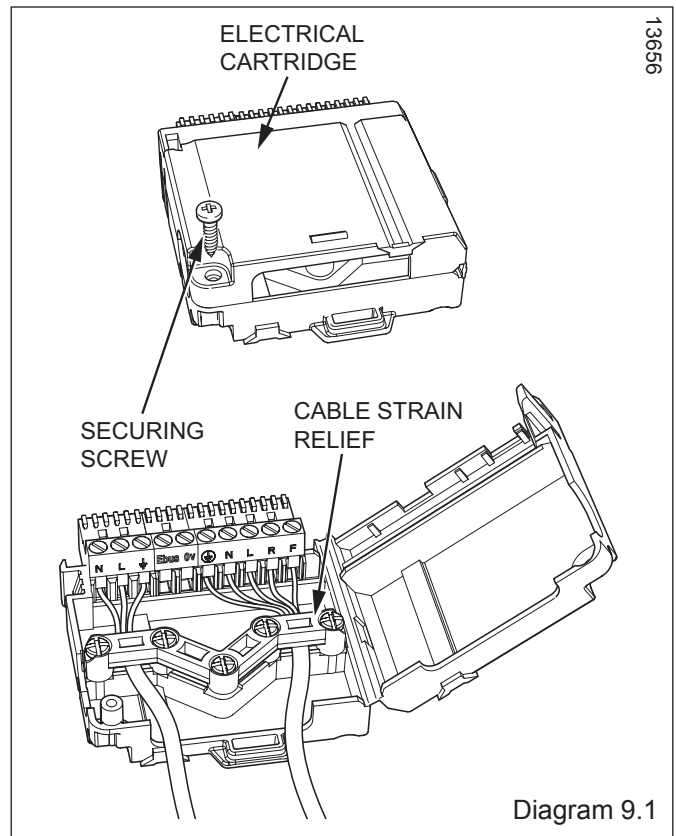

Diagram 9.1

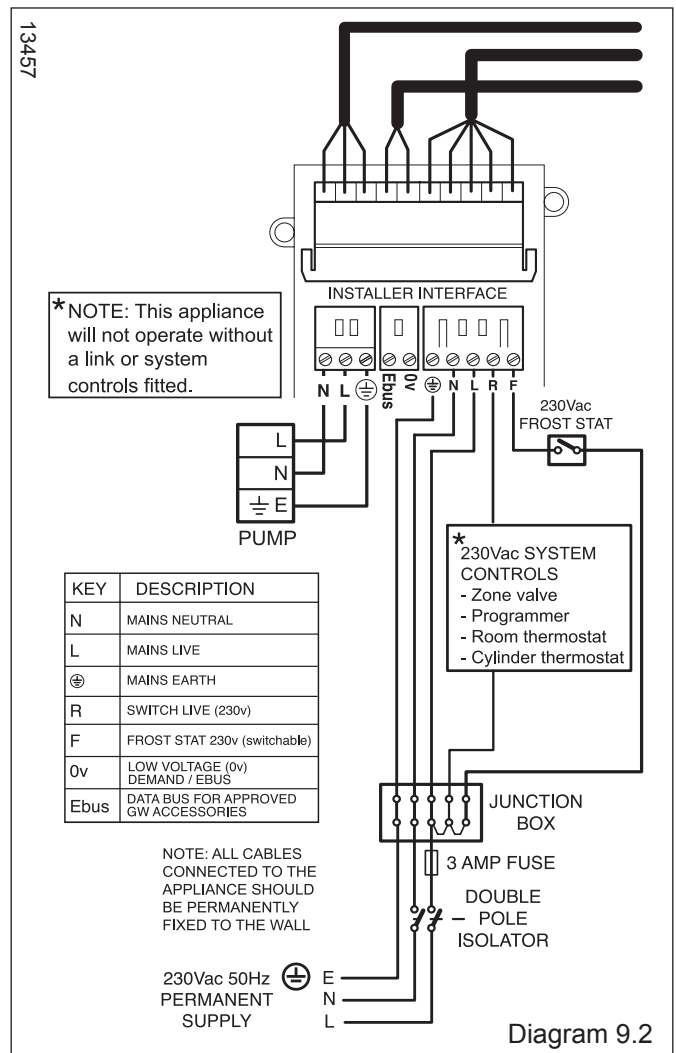

Diagram 9.2

9.4 Electrical Cartridge Securing

Close the cartridge and secure with the previously removed screw.
 Push the electrical cartridge into the interface housing on completion of the wiring, see diagram 9.3.
 Secure with the two cartridge retaining screws provided in the cartridge body.

9.5 Electrical Connections - Testing

Carry out preliminary electrical system checks as below:
 1. Test insulation resistance to earth of mains cables.
 2. Test the earth continuity and short circuit of cables.
 3. Test the polarity of the mains.
NOTE: If you require to test the appliance refer to section 12.

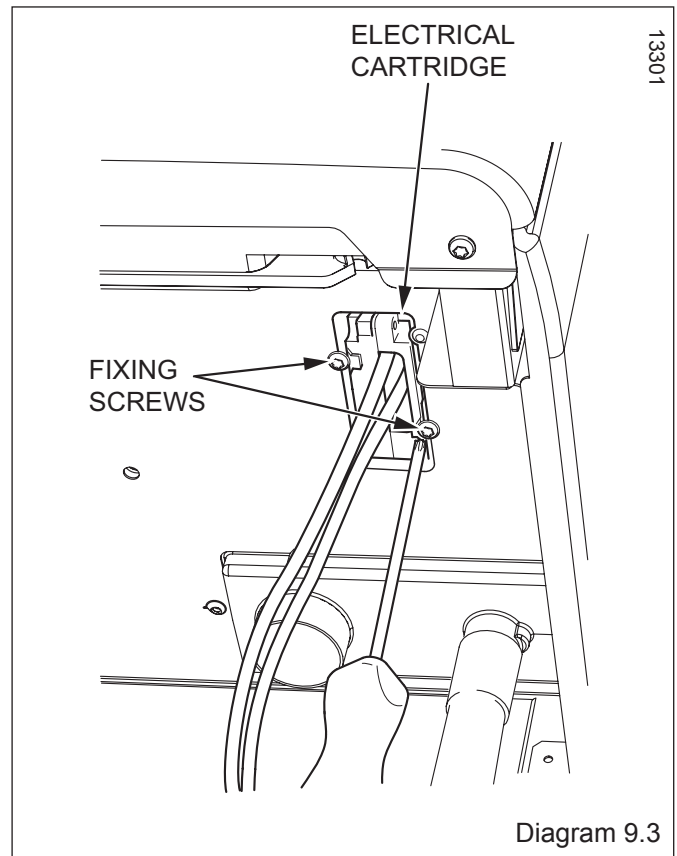

Diagram 9.3

Commissioning

IMPORTANT: At the time of commissioning, complete all relevant sections of the Benchmark Checklist located in the inside back pages of this document.

10.1 Preliminaries - All Systems

The commissioning should be carried out by a **competent person** approved at the time by the Health and Safety Executive and in accordance with the current issue of BS6798.

DO NOT operate the boiler without water.

Make sure that the system has been thoroughly flushed out with cold water and that all cleanser, if used, has been removed.

Isolate the boiler from the mains electrical supply.
 Test for gas tightness and purge air from the gas supply.

IMPORTANT: Before starting the boiler check that all flue connections are secure and sealed correctly.

10.2 Filling the Heating Circuit

With the gas isolation valve closed and with no demand from any external controls.

1. Fill the heating system.
 Sealed system only - fill the system to a pressure of 1.0bar.
2. Vent all air from the system - repeat as necessary until the system is full and all the air has been vented.

10.3 Gas Supply

The gas valve is factory set for natural gas (G20) and should need no adjustment. Turn on the gas supply at the isolation valve, see diagram 10.1. Check the supply pressure at the pressure test point is 20mbar.

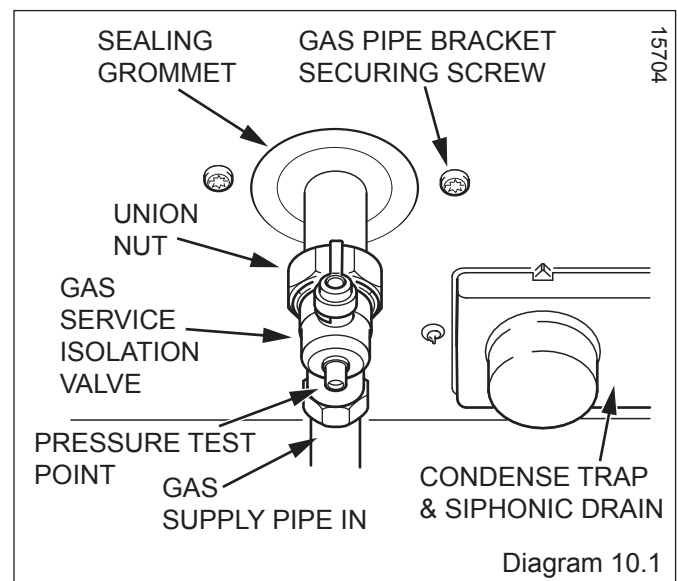
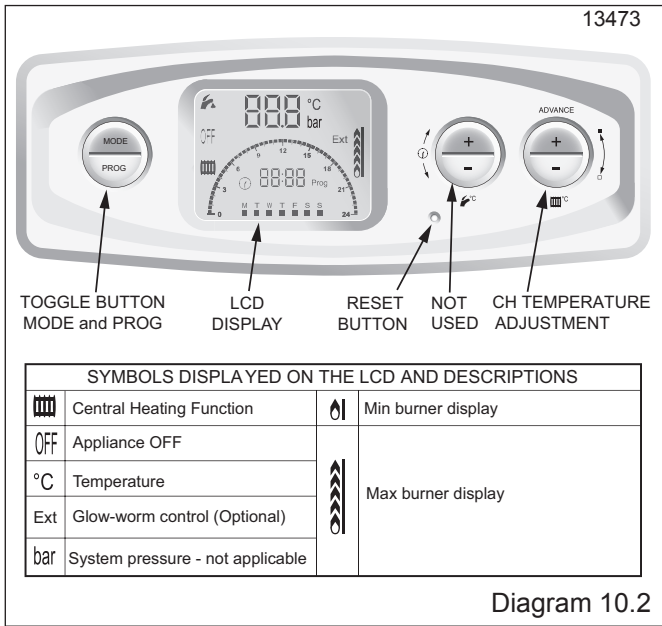

Diagram 10.1



10.4 Initial Lighting

Note: The combustion for this appliance has been checked, adjusted and preset at the factory for operation on natural gas (G20) as defined on the appliance data label.

Do not adjust the Gas/Air ratio valve.

No measurement of the combustion is necessary, having checked :

- the appliance has been installed in accordance with the instructions.
- the integrity of the flue system and flue seals.
- the integrity of the appliance combustion circuit and relevant seals.
- that all internal/external controls are calling for heat.
- the gas service isolation valve, diagram 10.1, is open.

As an option, a chargeable boiler performance and function service can be provided by Glow-worm Service by calling telephone No. 01773 828100.

LPG Conversion: See section 10.10.

NOTE: If you have fitted a Glow-worm Options Board Kit, please refer to the instructions supplied with the kit for completion of commissioning.

Do not operate the boiler without water.

Refer to diagram 10.2

1. With no demand from any external controls, switch on the electrical supply to the boiler.

Open the gas service isolation valve, see diagram 10.1.

2. Select your required function by pressing “ Mode “, scroll through your options and select one of the following:-

Central heating.

Boiler functions ALL switched off. “OFF”

3. Turn ON your external controls and select the room temperature required.

The boiler will operate automatically.

NOTE: The display will indicate the Heating system water temperature or a fault code if in a fault condition.

10.5 Check the Gas Inlet Pressure and Gas Rate

The supply from the governed meter must be of adequate size to provide a steady inlet working pressure of 20mbar (8in wg) at the boiler. On completion, test the gas installation for tightness using the pressure drop method and suitable leak detection fluid, purge as necessary.

Note: Due to the modulating operation of the boiler and the need to check the gas inlet pressure and measure the gas rate at maximum rate, it will be necessary to force it to maximum.

Press the “reset” button on the controls fascia, release and immediately press and hold in the “+” button. After approximately 5 seconds “Hi” will be displayed. Pressing the mode button when “Hi” is selected will force the boiler to maximum rate, the display will flash between “Hi” and the “default display” this will indicate the boiler has been forced to maximum.

Operational Gas Inlet Pressure

With ALL other gas appliances operating, check the operational supply pressure at the gas service isolation valve test point, see diagram 10.1.

The nominal supply pressure for Natural Gas (G20) is 20mbar.

The nominal supply pressure for LPG (G31) is 37mbar.

Turn the taps and appliances off, then disconnect the pressure gauge.

Additionally the safe nominal maximum heat input of the appliance can be achieved at an inlet pressure down to 15mbar.

Note: The **BURNER PRESSURE** cannot be measured and is not used to measure the gas rate.

Gas Rate

Make sure that ALL other gas burning appliances and pilot lights are off.

Check the gas rate using the gas meter test dial and stop watch, at least 10 minutes after the burner has lit, see table below for approximate rates.

Model	GAS RATES (G20) approx. after 10 mins from cold				GAS RATES (G31) approx. after 10 mins from cold	
	MIN m³/h	ft³/h	MAX m³/h	ft³/h	MIN kg/hr	MAX kg/hr
12hxi	0.53	18.7	1.29	45.6	0.39	0.95
15hxi	0.53	18.7	1.61	57	0.39	1.19
18hxi	0.53	18.7	2.00	70.6	0.39	1.47
24hxi	0.56	19.8	2.58	91.1	0.41	1.9
30hxi	0.56	19.8	3.02	107	0.41	2.22
38hxi	0.67	23.8	4.06	143	0.52	2.98

13862

In communal or LPG installations where the gas rate cannot be measured it is acceptable to measure the combustion rate as described in the servicing section.

On completion, press the “mode” and “+” buttons simultaneously, this will reset the boiler.

10.6 Range Rating - 38kW only

These boilers are fully modulating, therefore it is not necessary to range rate them, however, if desired, you can adjust the 38hxi boiler in 1kW increments between 10 and maximum output of your appliance, as described below. Please refer to the table to check the gas rates.

- Press and hold the 'MODE' button for 5 seconds. The display will change to flashing '0'.
- Use the heating '+' or '-' buttons to scroll to 96 (This is the installer level access password).
- Press 'MODE' to confirm, see diagnostic display 1.
- Press 'MODE' to change to the heating load value, see diagnostic display 2.
- Use the heating '+' or '-' buttons to set the heating design value required.
- Press the 'MODE' button to confirm the diagnostic number flashes, see diagnostic display 1.
- Hold 'MODE' for 5 seconds to save and exit.

10.7 Heating System

Check that all external controls are calling for heat. The boiler will fire automatically. Fully open all radiator valves, flow control valve 'A' and bypass valve 'B', see diagram 5.3. Balance the radiators as required and if fitted adjust valve 'A' to give the required system differential. Turn off all radiators that can be shut off by the user and check to see if less than the maximum differential allowed of 20°C can be achieved across flow and return.

Allow the system to reach maximum temperature then switch off the boiler by isolating from the electrical supply. The pump overrun will continue for 5 mins.

Drain the entire system rapidly whilst hot, using the drain taps at all the low points of the system. Fill and vent the system as described previously.

Lock or remove the handle from control valve 'A' to prevent unauthorised adjustment.

10.8 Completion

Fit the base coverplate, see diagram 10.3.

Ensure that the magnetic lighting instruction label is placed on the surface of the boiler casing

GB: It is a requirement that the "Benchmark" Installation, Commissioning and Service Record is completed and left with the user.

IE: it is necessary to complete a "Declaration of Conformity" to indicate compliance to I.S.813. An example of this is given in the current edition of I.S.813.

10.9 Instruct the User

- Demonstrate, then instruct the User about the lighting procedure and heating system controls operation.
- Advise that to ensure the continued efficient and safe operation of the boiler it is recommended that it is checked and serviced at regular intervals. The frequency of servicing will depend upon the installation conditions and usage, but in general, once a year should be enough.
- Draw attention, if applicable, to the current issue of the Gas Safety (Installation and Use) Regulations, Section 35, which imposes a duty of care on all persons who let out any property containing a gas appliance in the UK.
- The user shall not interfere with or adjust sealed components.
- It is the Law that any servicing is carried out by a **competent person** approved at the time by the Health and Safety Executive.

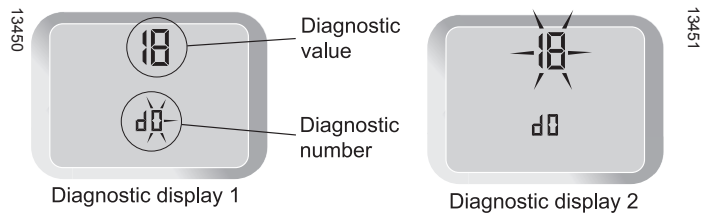

kW	m3/hr	ft3/hr	kW	m3/hr	ft3/hr
			24	2.5	88.3
38	4.06	143	23	2.4	84.8
37	3.9	138.5	22	2.3	81.2
36	3.8	135	21	2.2	77.7
35	3.7	131	20	2.1	74.2
34	3.6	127	19	2.0	70.6
33	3.5	124	18	1.9	67.1
32	3.4	120	17	1.8	63.6
31	3.3	117	16	1.7	60.0
30	3.2	113	15	1.6	56.5
29	3.1	109.5	14	1.5	53.0
28	3.0	106	13	1.4	49.5
27	2.9	102.4	12	1.3	45.9
26	2.8	98.9	11	1.2	42.4
25	2.6	91.8	10	1.12	38.9

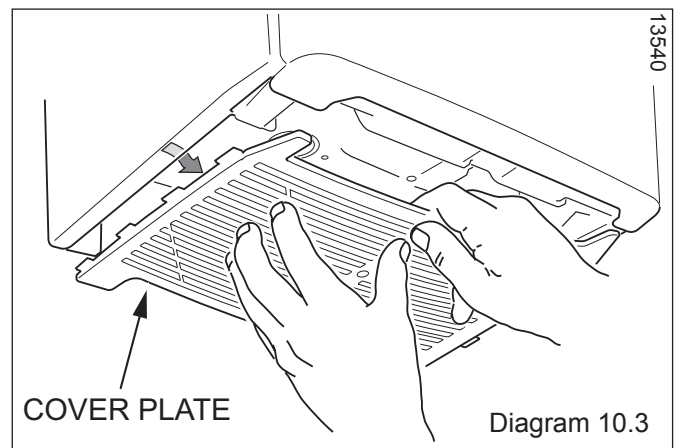

- Advise the user that, like all condensing boilers this appliance will produce a plume of condensation from the flue terminal in cool weather. This is due to the high efficiency and hence low flue gas temperature of the boiler.
 - Advise the user of the precautions necessary to prevent damage to the system, boiler and the building, in the event of the heating system being out of use during frost or freezing conditions.
 - Advise the user that the permanent mains electrical supply SHOULD NOT be switched off, as the built in frost protection and pump saver program will not operate.
 - Advise the User if the mains electricity and gas are to be turned off for any long periods during severe weather, it is recommended that the whole system, including the boiler, should be drained to avoid the risk of freezing.
- Note: Sealed System:** Contact your installation/servicing company as draining, refilling and pressurising MUST be carried out by a **competent person** approved at the time by the Health and Safety Executive.
- Leave these instructions and the 'Benchmark' Installation, Commissioning and Service Record with the user.

10.10 LPG CONVERSION - all models

As an option, a chargeable boiler performance and function service can be provided by Glow-worm Service by calling telephone No. 01773 828100.

NOTE: Steps 10.1 and 10.3 will need to be completed before the appliance can be converted.

This conversion should only be carried out by a **competent person** approved at the time by the Health and Safety Executive.

During the conversion to Propane use of a suitable flue gas analyser is necessary.

- The person carrying out a combustion measurement should have been assessed as competent in the use of a flue gas analyser and the interpretation of the results.

- The flue gas analyser used should be one meeting the requirements of BS7927 or BS-EN50379-3 and be calibrated in accordance with the analyser manufacturers' requirements.

- Competence can be demonstrated by satisfactory completion of the CPA1 ACS assessment, which covers the use of electronic portable combustion gas analysers in accordance with BS 7967, parts 1 to 4.

As an option a chargeable boiler only commissioning service can be provided by Glow-worm Service by calling telephone No. 01773 828100.

Tools required to make the conversion are a 2mm Allen key and an electrician's screwdriver.

Ensure that the appliance supply pressure = 37mbar.

- (1) Access the gas valve.
- (2) Refer to diagram 10.5 and turn the gas valve throttle fully clockwise.
- (3) Turn the throttle anti-clockwise by the number of turns shown in the table.
- (4) Ensure that the gas analyser is set to the correct fuel setting - Propane.
- (5) Attach combustion analyser to the combustion test point, refer diagram 11.1.

IMPORTANT: Remember to replace the cap on completion of the test.

- (6) Make sure that the external controls are calling for heat, then turn the mains electrical supply and gas service isolation valve on.
- (7) Switch the boiler on. The boiler should fire automatically.

NOTE: If the appliance does not light & goes to lockout (F1) turn the throttle anti-clockwise a further turn and press the reset button. The appliance will (after a short delay) again attempt to fire. Repeat this procedure (up to a total of 2 extra turns on the throttle screw) until the appliance lights. Several ignition attempts may be needed, to purge gas through the appliance, before a successful ignition is achieved.

G31 BURNER % CO ₂				
MODEL	CHECK (case on)	SETTING (case off)	Throttle TURNS	CO/CO ₂
12hxi	9.2 to 10.2	10.1 ^{+0.0} _{-0.8}	5	0.004
15hxi	9.8 to 10.8	10.1 ^{+0.5} _{-0.5}	5¼	0.004
18hxi	9.2 to 10.2	10.1 ^{+0.0} _{-1.0}	5	0.004
24hxi	9.2 to 10.2	10.1 ^{+0.3} _{-0.8}	5¼	0.004
30hxi	10.0 to 11.0	10.5 ^{+0.3} _{-0.8}	5½	0.004
38hxi	9.2 to 10.2	9.8 ^{+0.2} _{-0.8}	8	0.004

13868

- (8) Check and adjust the burner %CO₂ at maximum rate. Press the "reset" button on the controls fascia, release and immediately press and hold in the "+" button. After approximately 5 seconds "Hi" will be displayed. Pressing the mode button when "Hi" is selected will force the boiler to maximum rate, the display will flash between "Hi" and the "default display" this will indicate the boiler has been forced to maximum.
- (9) If necessary, adjust the burner % CO₂ to the value shown in the "SETTING" column of the table, by turning the throttle screw (anti-clockwise to increase), see diagram 10.5 no more than 1/8 of a turn, waiting a minute to allow for the appliance to stabilise before checking or making further adjustments.
- (10) Exit the check sequences press the "mode" and "+" buttons simultaneously, this will reset the boiler to the default display.
- (11) Check the burner % CO₂, at minimum rate, to the value shown in the "SETTING" column of the table.
- (12) If adjustment is required, press the "reset" button on the controls fascia, release and immediately press and hold in the "+" button. After approximately 5 seconds "Hi" will be displayed. Pressing the "+" or "-" buttons will cycle between "Hi" and "Lo". Pressing the mode button when "Lo" is selected will force the boiler to minimum rate, the display will flash between "Lo" and the "default display" this will indicate the boiler has been forced to minimum.
- (13) Adjustment of the %CO₂ is very coarse so carefully adjust the %CO₂ to the value shown in the "SETTING" column of the table with the offset adjustment, see diagram 10.5 and %CO₂ Table (Rotate clockwise to increase).
- (14) To exit the function press the "mode" and "+" buttons simultaneously, this will reset the boiler to the default display.
- (15) Repeat (8) and check CO₂ at maximum rate - adjust if necessary. Check that the CO/CO₂ ratio is less than the value in the table below.
- (16) Remove analyser probe from the test point and replace the cap. Refit the control panel.
- (17) **IMPORTANT: Fit the LPG conversion label supplied in the documentation pack to the inner front panel alongside the data label. Refit the inner door and outer door.**
- (18) Continue commissioning from 10.5.

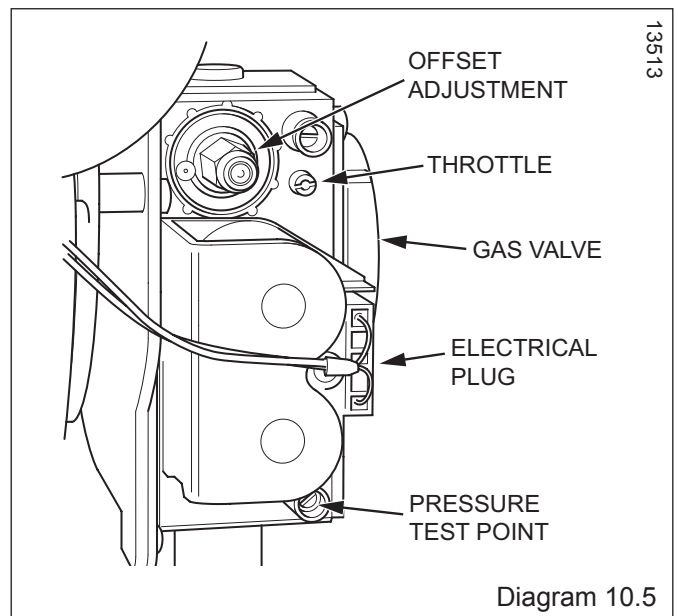

13513

Diagram 10.5

IMPORTANT NOTES:

1. To ensure the continued efficient and safe operation of the boiler it is recommended that it is checked and serviced at regular intervals. The frequency of servicing will depend upon the particular installation and usage, but in general once a year should be enough.
2. It is the Law that any servicing is carried out by a **competent person** approved at the time by the Health and Safety Executive.
3. Before commencing with a service or replacement of parts the boiler should be isolated from the electrical supply and the gas supply should be turned off at the gas isolation valve.
4. When replacing a part on this appliance, use only spare parts that you can be assured conform to the safety and performance specification that we require. Do not use reconditioned or copy parts that have not been clearly authorised by Glow-worm.
5. If any electrical connections have been disconnected and after their connection, checks to the earth continuity, polarity, short circuit and resistance to earth must be repeated using a suitable multimeter, as described in section 12.
6. After servicing, complete the relevant Service Interval Record section of the Benchmark Checklist located in the inside back pages of this document.

Servicing

General Inspection

Prior to, during servicing and after any maintenance or changed parts, the following must be checked.

- The integrity of the flue system and flue seals.
 - The integrity of the appliance combustion circuit and relevant seals.
 - Electrical, gas and water connections.
 - System pressure.
 - the combustion performance, refer to the following procedure.
 - The operational gas inlet pressure and gas rates, refer to the commissioning section paragraph 10.5.
- Correct any fault before continuing.

COMPETENCY TO CARRY OUT THE CHECK OF COMBUSTION PERFORMANCE

NOTE: BS 6798: 2009 Specification for installation and maintenance of gas-fired boilers of rated input not exceeding 70kW net advises that:

- The person carrying out a combustion measurement must be assessed as competent in the use of a flue gas analyser and the interpretation of the results.
- The flue gas analyser used should be one meeting the requirements of BS7927 or BS-EN50379-3 and be calibrated in accordance with the analyser manufacturers' requirements.
- Competence can be demonstrated by satisfactory completion of the CPA1 ACS assessment, which covers the use of electronic portable combustion gas analysers in accordance with BS 7967, parts 1 to 4.
- Ensure that the gas analyser is set to the correct fuel setting.
- Select the "☐", central heating function by pressing the "Mode" button repeatedly, refer to commissioning section. The boiler should fire automatically.

NOTE: Safe combustion can only be verified by measuring CO/CO2 ratio. This must not exceed the value shown in the table below.

COMBUSTION CHECK AND SETTING THE AIR/GAS RATIO VALVE

- Remove the front casing panel, see diagram 11.2 and hinge down the control box. Taking care not to touch any internal components, proceed as follows:
- Connect the CO2 combustion analyser to the relevant test point, see diagram 11.1.

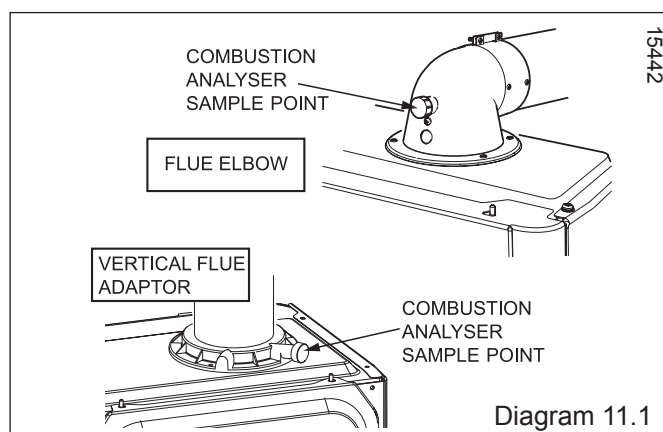

Diagram 11.1

G31 BURNER % CO2			
MODEL	CHECK (case on)	SETTING (case off)	CO/CO2 ratio
12hxi	9.2 to 10.2	10.1 +0.0 - 0.8	0.004
15hxi	9.8 to 10.8	10.1 +0.5 - 0.5	0.004
18hxi	9.2 to 10.2	10.1 +0.0 - 1.0	0.004
24hxi	9.2 to 10.2	10.1 +0.3 - 0.8	0.004
30hxi	10.0 to 11.0	10.5 +0.3 - 0.8	0.004
38hxi	9.2 to 10.2	9.8 +0.2 - 0.8	0.004
G20 BURNER % CO2			
MODEL	CHECK (case on)	SETTING (case off)	CO/CO2 ratio
12hxi	8.5 to 9.6	9.1 +0.2 - 0.5	0.004
15hxi	8.5 to 9.6	9.1 +0.2 - 0.5	0.004
18hxi	8.5 to 9.6	9.1 +0.2 - 0.5	0.004
24hxi	8.5 to 9.6	9.1 +0.2 - 0.5	0.004
30hxi	8.5 to 9.6	9.1 +0.2 - 0.5	0.004
38hxi	8.5 to 9.6	8.8 +0.2 - 0.5	0.004

1. Maximum Rate Check and Adjustment

NOTE: To verify the maximum gas rate CO₂ setting the appliance must be checked at the maximum rate first. Press the “reset” button on the controls fascia, release and immediately press and hold in the “+” button. After approximately 5 seconds “Hi” will be displayed. Pressing the mode button when “Hi” is selected will force the boiler to maximum rate, the display will flash between “Hi” and the “default display” this will indicate the boiler has been forced to maximum. Wait until the CO₂ value is stable and check that the value is within the range specified in table in the “check” column.

If the combustion reading is not within the acceptable values AND the integrity of the complete flue system and combustion circuit seals have been verified and the inlet gas pressure (and gas rate) have been verified, then, it will necessary to adjust the combustion rate of the appliance.

NOTE: Adjustment is made by turning the gas valve throttle an 1/8 of a turn, waiting 1 minute to allow the appliance to stabilise before checking or making further adjustments.

- Rotate the “throttle”(anti-clockwise to increase), to the required CO₂, refer to diagram 10.5 and the “SETTING” column in the table.
- Exit the forced rate function, press the “mode” and “+” buttons simultaneously, this will reset the boiler to the default display. Now proceed to check the minimum rate adjustment.

2. Minimum Rate Check and Adjustment

• Now check the minimum gas rate CO₂ setting: Press and release the “reset” button on the controls fascia, then immediately press and hold in either of the “+” buttons. After approximately 5 seconds “Hi” will be displayed. Pressing the “+” or “-” buttons will toggle between “Hi” and “Lo”. Press the mode button when “Lo” is selected, this will force the boiler to minimum rate and the display will flash “Lo”, indicating the boiler is operating at minimum.

• Wait until the CO₂ value is stable and check that the value is within the range specified in table in the “check” column. If adjustment is necessary, proceed as follows:

NOTE: Adjustment of the CO₂ at minimum rate is very coarse and should not be adjusted more than an 1/8 of a turn at a time. Wait 1 minute to allow the appliance to stabilise before checking or making further adjustments.

- Gradually rotate the “offset adjustment” (anti-clockwise to decrease) to the required CO₂, refer to diagram 10.5 and the “SETTING” column in the table.
- Exit the minimum rate function, press the “mode” and “+” buttons simultaneously, this will reset the boiler to the default display.

3. Re-Check CO₂ and check the CO/CO₂ combustion ratio.

• Re-check the maximum and minimum CO₂ values to ensure that they are within the “setting” limits in the table then check the CO/CO₂ combustion ratio does not exceed the value in the CO/CO₂ column of the table. If the CO/CO₂ setting exceeds the value in the table, a complete servicing of the appliance will be necessary, refer to section 11.1. If the CO₂ and the CO/CO₂ ratio falls within the tolerances quoted, exit the function press the “mode” and “+” buttons simultaneously, this will reset the boiler to the default display. Remove the analyser probe and replace the cap on the sampling point, replace the controls fascia, inner and front casing panels.

IMPORTANT: Remember to replace the sample point cap on completion of the test.

GAS RATE CHECK

Check the gas rates as described in the commissioning section.

COMPLETION

If it is not possible to achieve the required results for either the combustion or gas rates, it will be necessary to complete a full service of the appliance and then repeat the combustion check procedure. If after servicing and adjustment of the appliance the combustion values are still unacceptable and after further remedial work has been carried out, the appliance must be disconnected until the CO/CO₂ ratio is acceptable. Advice can be sought from the Glow-worm Technical Helpline.

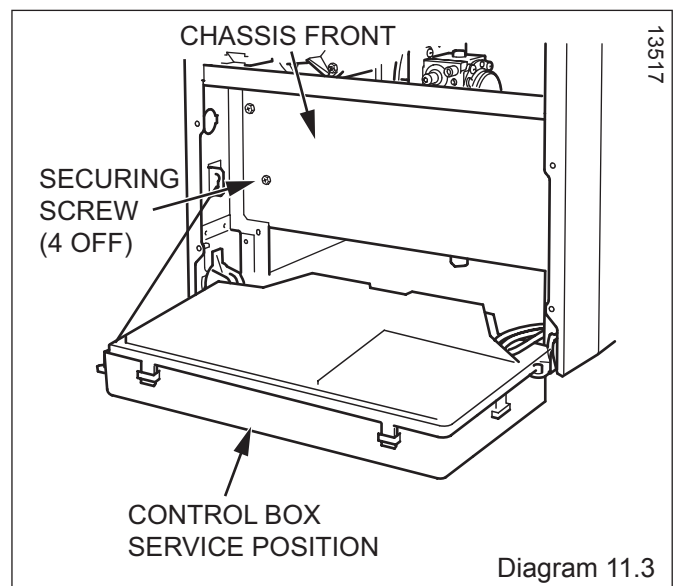
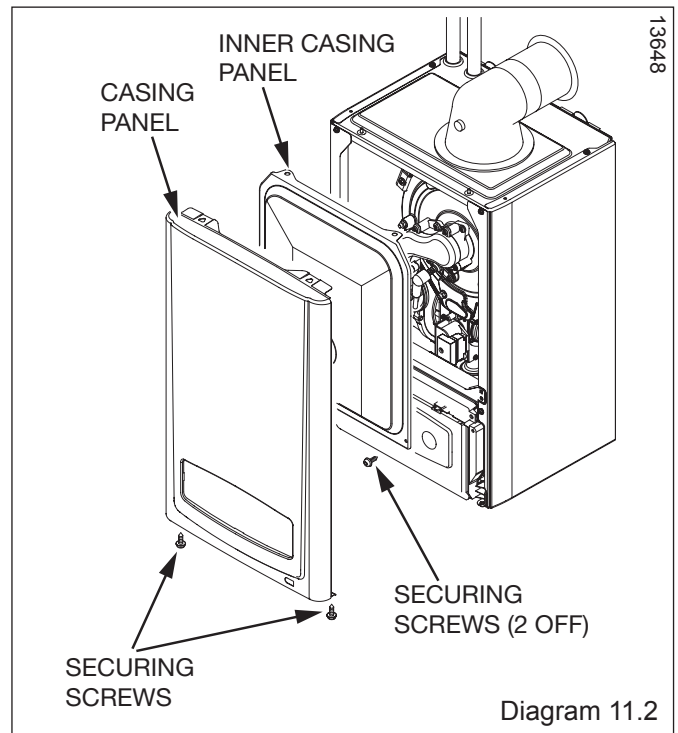

11.1 Servicing

IMPORTANT: If the Combustion CO₂, CO/CO₂ ratio & Gas rate checks did not require adjustment then it will not be necessary to complete a full service.

In any case, a full service including the replacement of the burner door seal must be carried out at least once every 5 years.

All routine servicing requirements can be achieved by the removal of the front panel, see diagram 11.2. Position the control box into the service position, see diagram 11.3. Before commencing with a service or replacement of parts.

The boiler should be isolated from the electrical and gas supplies.

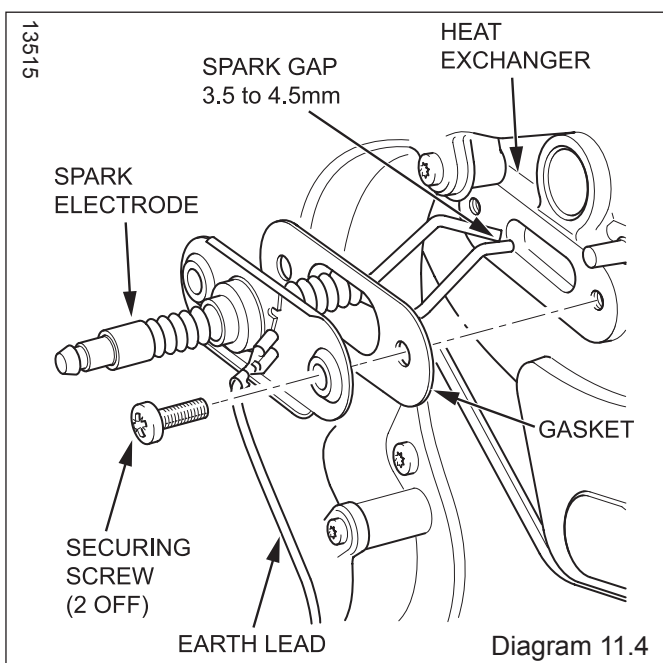

Diagram 11.4

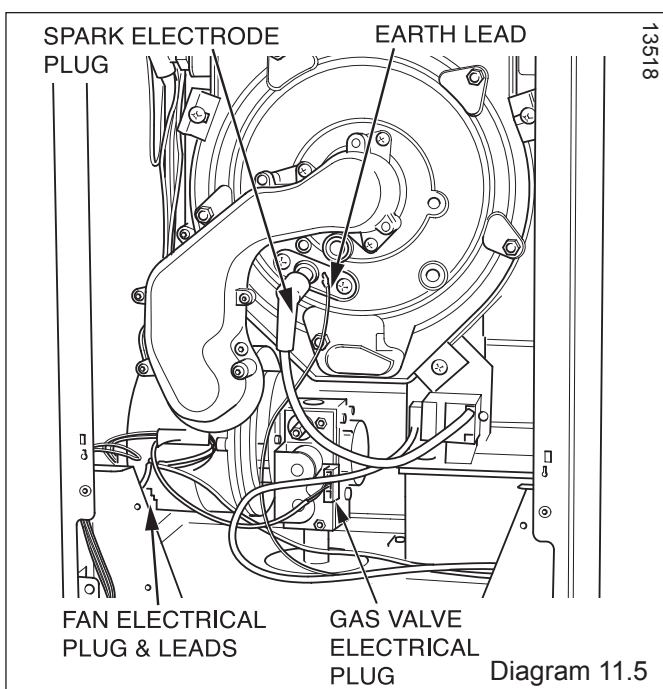

Diagram 11.5

11.2 Spark Electrode

Disconnect the spark electrode plug and earth lead, see diagram 11.5. Remove the two securing screws and withdraw the spark electrode carefully from the combustion chamber, see diagram 11.4.

Inspect the tips for damage.

Clean away any debris and check the spark gap is 3.5 to 4.5 mm.

Check the electrode gasket for signs of damage and replace if necessary.

11.3 Burner

IMPORTANT:

- The following procedure will require that you replace the burner door seal and nyloc nuts, Spare kit 801635.
- Removal of the burner is not necessary during a normal service, but if it is removed it will require a new gasket, see diagram 11.6.
- When replacing ensure that the sealing grommet, situated below the gas valve is correctly re-seated.

Disconnect the gas valve electrical plug at the gas valve, see diagram 11.5.

Disconnect the electrical plug from the fan.

Disconnect the spark electrode plug and earth lead, refer to diagram 11.6.

Remove the gas pipe retaining clip.

Remove the five combustion chamber/burner door securing nuts, see diagram 11.7, these should be discarded and replaced with the new nylocs nuts supplied in the burner door seal kit.

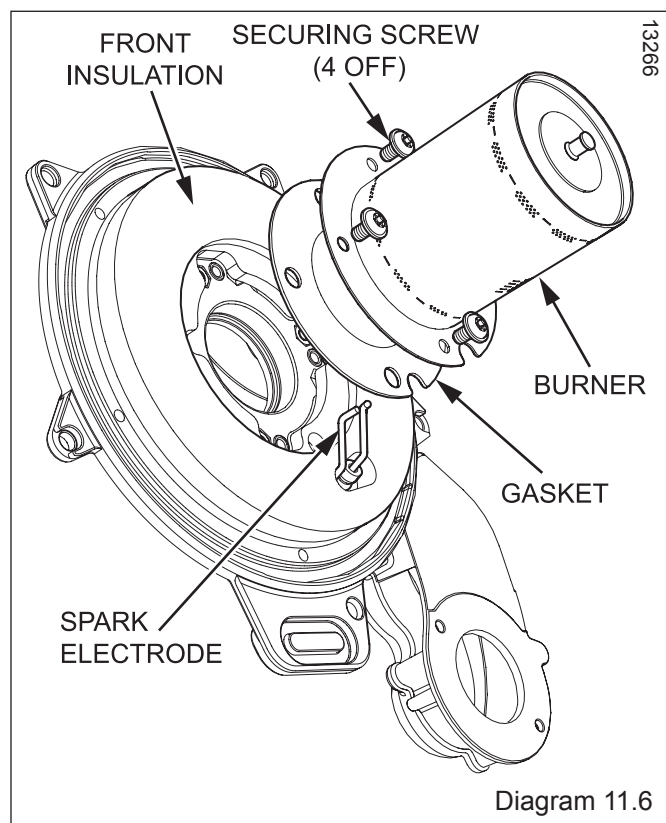
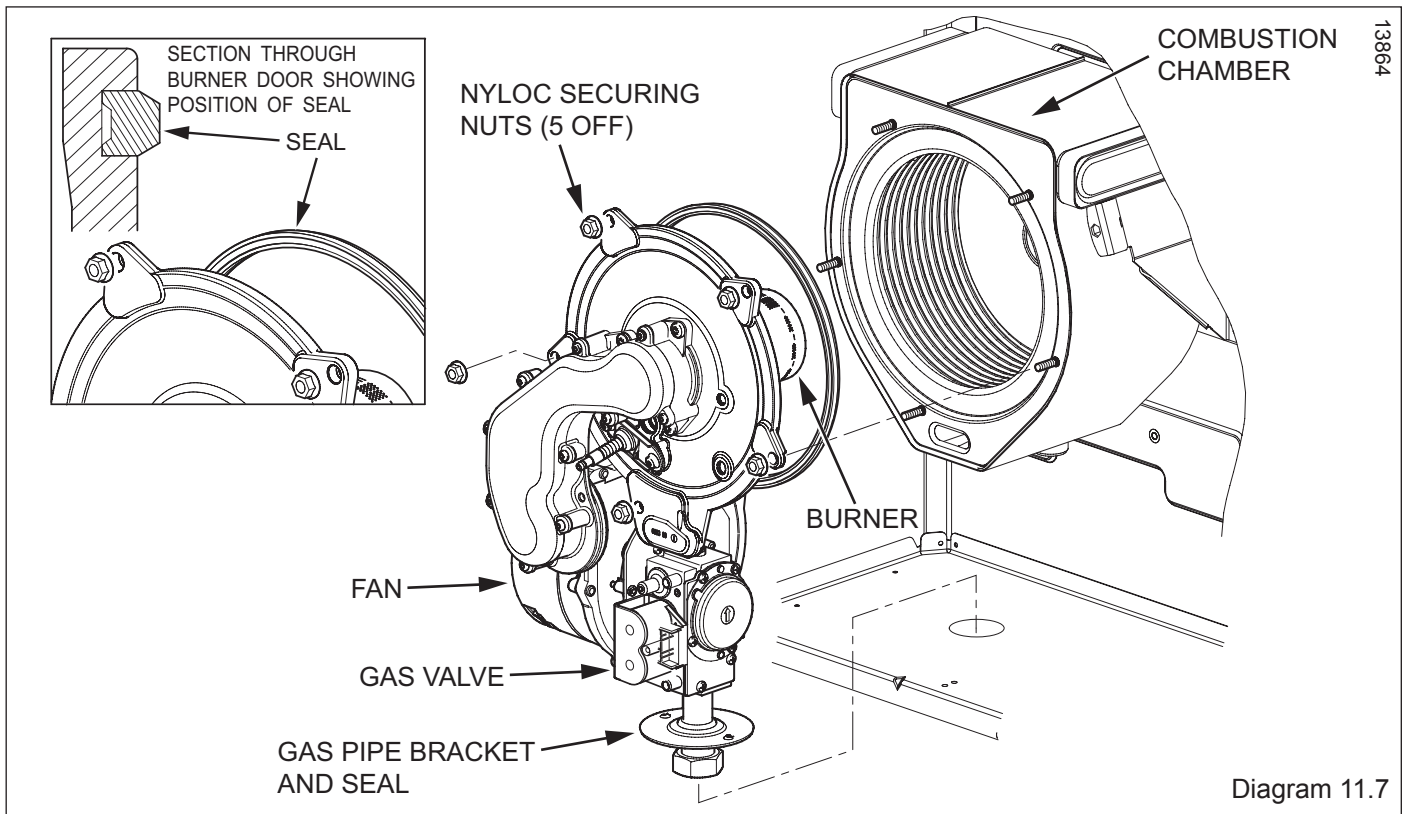

Diagram 11.6



13864

Gently remove the fan, gas valve and burner assembly from the combustion chamber.
 Clean the burner with a soft brush taking great care not to damage the front insulation. **DO NOT** use wire or sharp instruments to clean the holes of the burner.
 Inspect the burner for any signs of damage.
 Remove and discard the burner door seal and replace with new, see diagram 11.7.

11.4. Combustion Chamber and Heat Exchanger

Remove loose debris from inside the combustion chamber using a soft brush and vacuum cleaner.
 Carefully flush by spraying water into the heat exchanger, any remaining debris should pass through the condensate trap (Ensure the water is kept away from electrical components).

11.5 Inner Casing Panel Seal check

Check the condition of the seal, if worn or damaged remove the seal and thoroughly clean the casing surface before fitting the new seal, see diagram 11.8.

Refit the inner casing panel.

NOTE: Ensure the seal is fitted correctly giving an airtight joint.

11.6 Service Completion

Re-check the combustion as described at the beginning of this section.

On completion of the service the "Benchmark" Service Record should be completed.

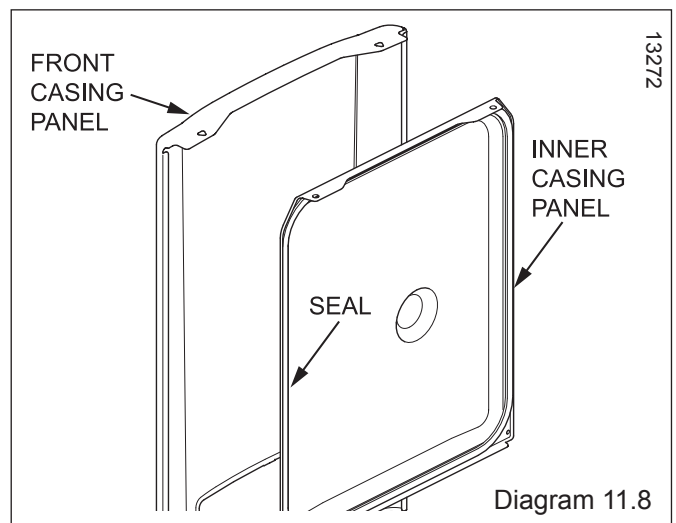

13272

Fault Finding

12.1 Preliminary fault finding

The following checks should be performed before proceeding onto specific diagnostics:

- Check the external electrical supply to the boiler is on and a supply of 230V is present at the 'L' and 'N' terminals on the installer interface, refer to section 10.4 for access and diagram 12.4.
- Check the electrical installation and appliance, carry out tests for earth continuity, polarity, short circuit and resistance to earth, using a suitable multimeter.

An aid to test

Remove the front casing panel, see diagram 11.2 and the control panel securing screw, see diagram 12.1 then lower into service the position.

Remove the rear panel by prising the retaining clips, see diagram 12.1.

Carry out the tests at connector plug X17, see diagram 12.2. Check chassis earth at a bare metal point on the boiler.

- Check that there is a gas supply to the boiler and the gas service isolation valve is turned on, see diagram 10.1.
- Check pressure at the gas service isolation valve, refer to section 10.5.
- Check that the heating system pressure indicates at least 1mb, if not, fill and vent the system as described in section 10.2.
- Check that all external controls are on.
- Check the functional flow diagram, 12.5.

12.2 Fault Codes

Fault codes take priority over all other display functions in the event of a fault occurring, refer to diagram 12.6.

If multiple faults occur the codes will be displayed for approx. 2 seconds, alternatively.

12.3 Fault Memory

The Fault memory stores details of the ten most recent faults. To access this menu, refer to diagram 12.3:

- Press and hold 'MODE' for 5 seconds.
- When the display shows a flashing '0' press 'MODE' button.
- Press a '+' button to scroll back through the fault memory (Position 1 is most recent), see fault memory display. To exit this menu, press the 'MODE' button.

12.4 Diagnostic Menu

The Diagnostic Menu provides the ability to view and change certain parameters. See diagram 12.7 for available parameters.

12.5 Status Codes

The status codes provide information about the current operating condition of the boiler and can be accessed through the diagnostic display, refer to diagram 12.8.

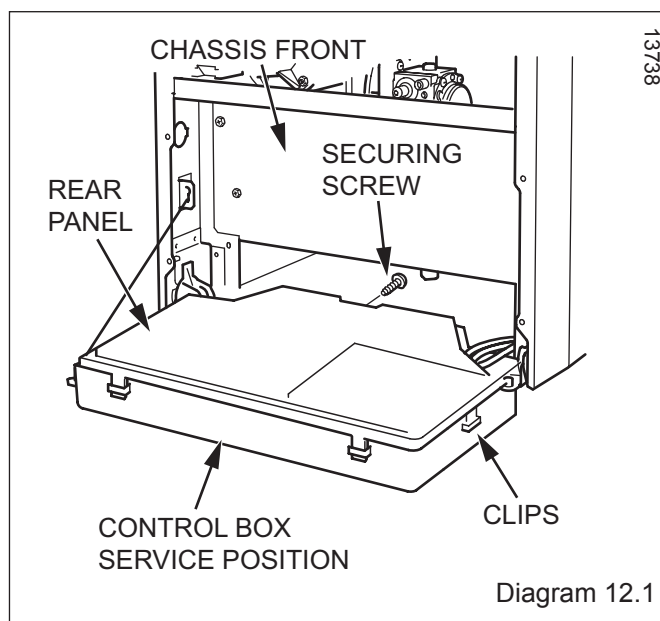

13738

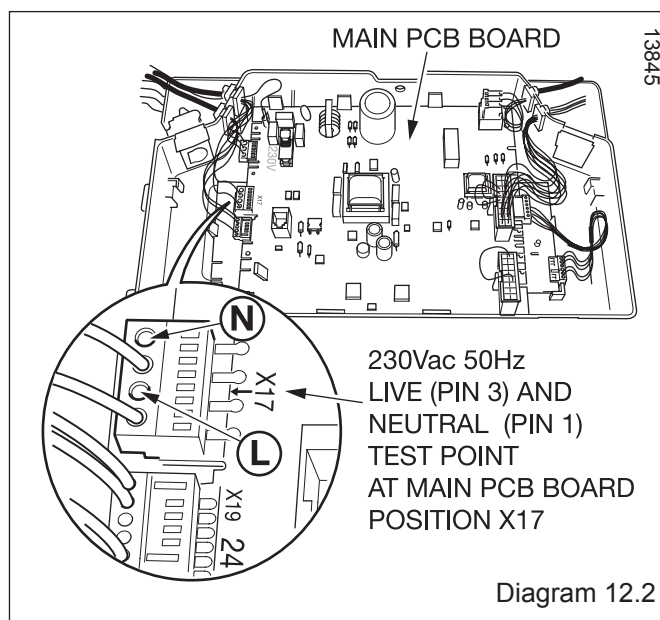

13845

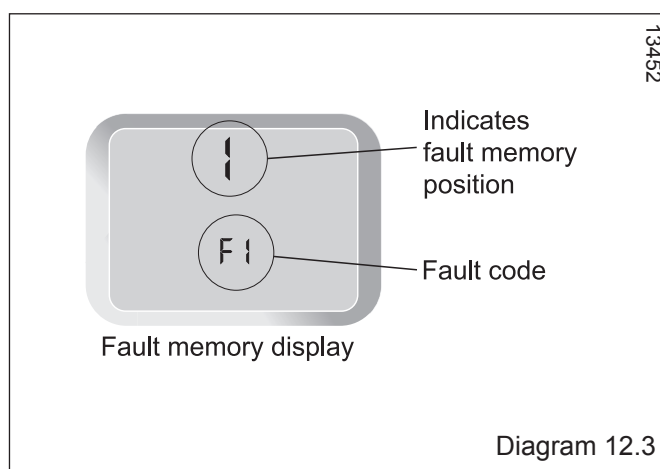

13452

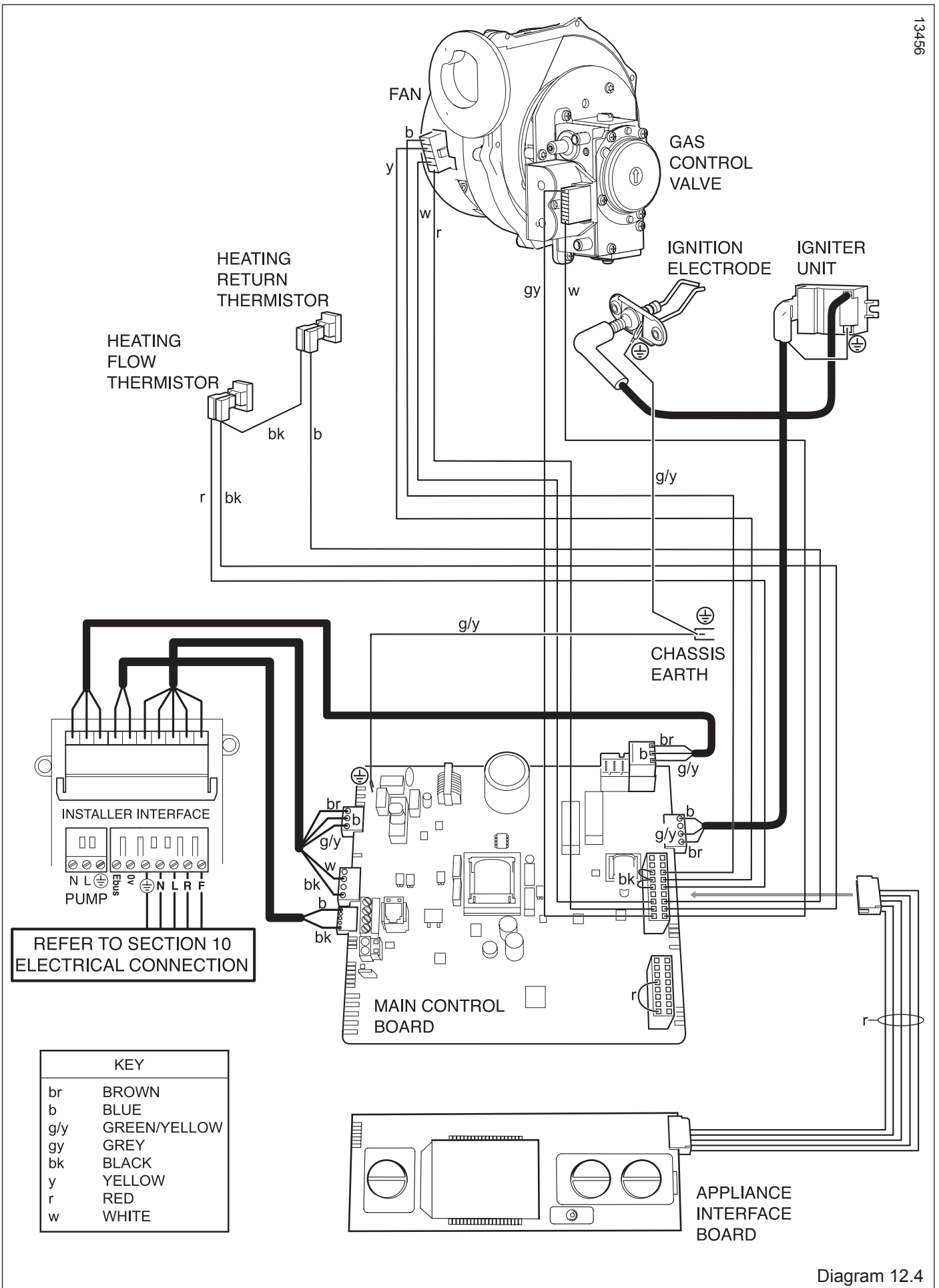

KEY	
br	BROWN
b	BLUE
g/y	GREEN/YELLOW
gy	GREY
bk	BLACK
y	YELLOW
r	RED
w	WHITE

Diagram 12.4

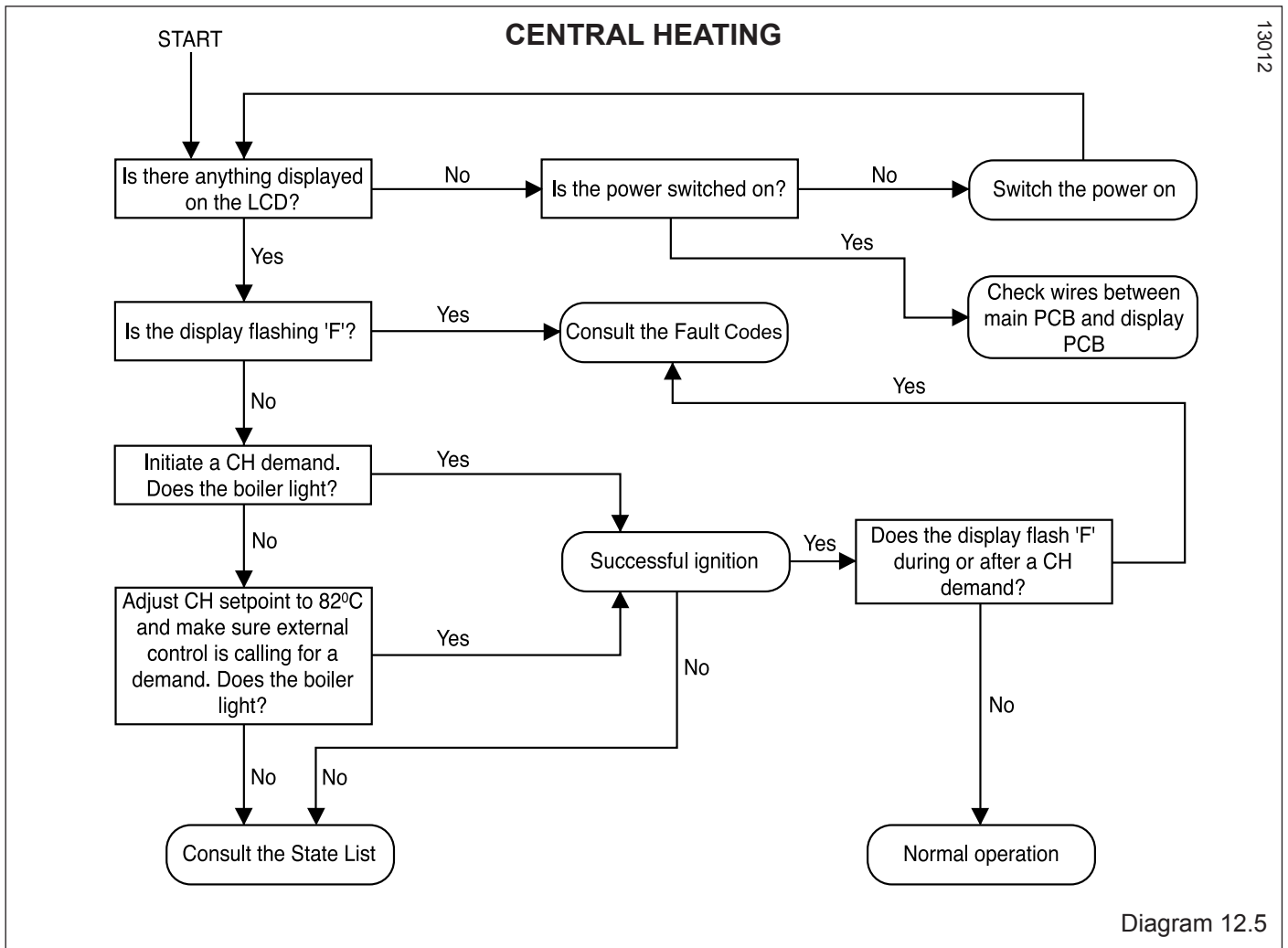

Fault Codes

CODE	DESCRIPTION	POSSIBLE CAUSE
F1	Boiler has attempted to light 5 times and failed on all occasions	Gas tap is closed. Gas valve connector is loose, unconnected, faulty, or wires are trapped. Ignitor connectors are loose, unconnected, faulty, trapped. Faulty Ignitor. Low gas inlet pressure. Incorrect gas valve adjustment. Electrode Ignition leads loose, unconnected, faulty, trapped. Electrode broken, defective, or position incorrect. Air inlet blocked, flue inlet blocked, flue duct leaking. Earthing connection loose, disconnected. Condensate blocked.
F3	Fan fault	Fan speed incorrect. Fan connector loose, unconnected, faulty or wires trapped. Faulty fan.
F4	Flame goes out whilst lit during a demand	Gas tap is closed. Gas valve connector is loose, unconnected, faulty, or wires are trapped. Ignitor connectors are loose, unconnected, faulty, trapped. Faulty Ignitor. Low gas inlet pressure. Incorrect gas valve adjustment. Electrode Ignition leads loose, unconnected, faulty, trapped. Electrode broken, defective, or position incorrect. Air inlet blocked, flue inlet blocked, flue duct leaking. Earthing connection loose, disconnected. Condensate blocked.
F5	Overheat	Boiler has overheated – allow to cool then press reset button
F6	Central Heating Flow Thermistor connection fault	Thermistor wires unconnected, faulty, trapped.
F10	Central Heating Return Thermistor connection fault	Thermistor wires unconnected, faulty, trapped.
F11	Flow and/or return NTC faulty	Thermistor wires unconnected, faulty, trapped.
F13	PCB Memory or sensing fault	Loose connections on Main PCB or display PCB. Central Heating Flow or Return Thermistor wires unconnected, faulty, trapped. Electrode Ignition leads loose, unconnected, faulty, trapped. Earthing connection loose, disconnected.
F14	Gas Valve control defective	Gas valve connector loose, wires unconnected, faulty or trapped. Faulty main board. Faulty gas valve.
F15	eBus Voltage failure	Short circuit on eBus, overload on eBus.

Diagram 12.6

Fault Codes (continued)

F22	Low Water pressure or Ignition temperature rise too slow	Not enough water in the system. Central heating flow or return thermistor wire loose, faulty, trapped. Central heating flow or return thermistor not connected to pipe correctly. Air in the system. Faulty pump or pump speed too fast.
F25	Central Heating Flow temperature rise too high during operation. Central Heating Return temperature rise or temperature difference too high during operation. Central Heating Temperature difference (between Flow and Return) too high during operation.	Check thermistors are connected to pipes correctly. Air in the system. System is too restrictive.
F43	Generic error	Check all electrical connections - internal & external
F70	Software incompatible	Telephone Group Service
F77	Condensate pump error (Option)	Trapped, faulty wiring, blockage in condensate pump.

NO DISPLAY or 'Er' displayed - Check connection from display PCB to main PCB connector X51

Diagram 12.6

Diagnostic Menu

The Diagnostic Menu provides the ability to view and change certain parameters.

See Diagram 12.7 for available parameters.

To enter the diagnostic menu:

- Press and hold the 'MODE' button for 5 seconds. The display will change to flashing '0'.
- Use the '+' or '-' buttons to scroll to 96 (This is the installer level access password).
- Press 'MODE' to confirm, see diagnostic display 1. Use the '+' or '-' buttons to view the appropriate diagnostic number, see diagram 12.7.

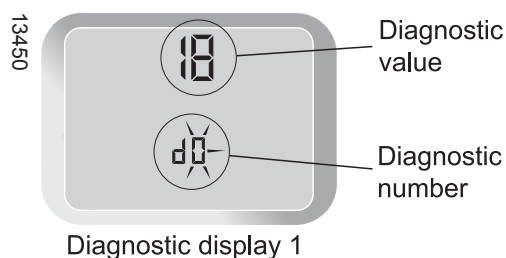

Diagnostic display 1

If necessary the values can be changed by:

- Pressing the 'MODE' button.
 - The diagnostic value flashes, see diagnostic display 2.
 - Use the '+' and '-' buttons to cycle through available values.
 - The change is saved by pressing 'MODE' once more. (NOTE: Only certain parameters can be adjusted)
- To exit the diagnostic menu press and hold the 'MODE' button for 5 seconds.

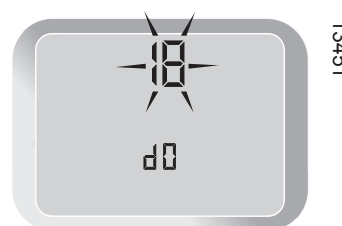

Diagnostic display 2

Diagnostic Menu - Level 1 Installer Access

Display	Description	Range
■ d.0	Heating part load	Adjustable heating part load in kW (factory setting: max. output)
■ d.1	Water pump over run time for heating mode	2 - 60 min (factory setting: 5 min)
■ d.2	Max. burner anti cycling period at 20°C Flow temperature	3 - 60 min (factory setting: 20 min)
d.4	Tank temperature	in °C -99 will be displayed. Reserved for future use.
d.5	Flow temperature setpoint	In °C, min. 38 and max. 82
d.8	External controls heat demand	0= no heat request (open) 1 = heat request (closed)
d.9	Flow target temperature from external intelligent control	In °C
d.10	Status central heating pump	1,2 = on, 0 = off
d.11	Status additional heating pump (option)	1 to 100 = on, 0 = off
d.13	Hot water circulation pump (via accessory module)	1 to 100 = on, 0 = off
d.23	Summer/Winter function	1 = Winter, 0 = Summer
d.25	Hot water activation via eBUS Control	1 = yes, 0 = no
■ d.27	Option Relay 1	Reserved for future use
■ d.28	Option Relay 2	Reserved for future use
d.33	Fan speed target value	in rpm/10
d.34	Fan speed actual value	in rpm/10
d.40	Flow temperature	Actual value in °C
d.41	Return temperature	Actual value in °C
d.44	Ionisation current	Actual value (10nA) > 80 no flame < 40 good flame
d.60	Number of safety temperature limiter cut offs	Quantity
d.61	Number of lock outs	Number of unsuccessful ignitions in the last attempt
d.64	Average ignition time	In seconds
d.65	Maximum ignition time	In seconds
d.67	Remaining burner anti cycling time (block time)	Minutes
d.68	Unsuccessful ignitions in the first attempt	Quantity
d.69	Unsuccessful ignitions in the second attempt	Quantity
d.76	Appliance variant (device specific number)	00 to 99
d.80	Heating operating hours	in h
d.82	Cycles in heating mode	Quantity
d.90	External intelligent control connected	1 = identified, 0 = unidentified (eBUS Address <= 1 0)
■ d.91	Internal Programmer type	0:24 hour (default) 1:7 day
■ d.92	Enable/Disable Internal Programmer	0: CH Off, DHW Off (default) 1: CH Off, DHW On 2: CH On, DHW Off 3: CH On, DHW On
■ d.97	Activation of the second diagnostic level	Password needed
d.99	State List	(see State Lists table)

■ Indicates read and write function - all other diagnostics are read only

Diagram 12.7

State list - Accessed through Diagnostic Codes - Level 1, Installer Access d.99

STATE LISTS

	Central heating mode (Priority 3)	Description
S.00	no heating required	} NORMAL OPERATING STATE FOR CENTRAL HEATING
S.01	fan pre-run	
S.02	pump pre-run	
S.03	ignition	
S.04	burner on	
S.05	pump / fan overrun	
S.06	fan overrun	
S.07	pump overrun	
S.08	Anti cycling period	
	Special cases of status messages	
S.30	No Heating demand from external controls 230V	Check wiring in external controller. Check wiring at Installer Interface.
S.31	summer mode	Check CH setpoint / Check external controls
S.32	Fan speed variation too high – waiting during blocking function	Check fan connection.
S.34	frost protection active (Priority 4)	Temperature below 8°C - check thermistor connection if this is not true.
S.42	Accessory Module is blocking burner operation	Check accessory module.
S.53	waiting time: temperature difference flow - return sensor too high (Check thermistor fit)	Check flow & return thermistor connections to pipes. Check harness connection to thermistor. Check harness wires are not trapped between any internal components.
S.54	waiting time: no water in system, temperature (gradient error) rise flow / return sensor too high	Check flow & return thermistor connections to pipes. Check harness connection to thermistor. Check harness wires are not trapped between any internal components.
S.76	Waiting period – pressure sensor	Check system pressure - default display.
S.96	Return-Sensor check is running, demand (DHW or heating) is blocked	Check return thermistor connection to pipe. Check harness connection to thermistor.
S.98	Flow/Return-Sensor check is running, demand (dhw or heating) is blocked	Check flow & return thermistor connections to pipes. Check harness connection to thermistor. Check harness wires are not trapped between any internal components.

Diagram 12.8

13 Replacement of Parts

13.1 General

IMPORTANT: The replacement parts described in sections 13.5 to 13.9 and section 13.12, will require the removal of the burner module assembly and the replacement of the burner door seal and self locking nuts.

Replacement parts that have associated components that need replacing on removal, i.e. 'O' ring, seals, gasket, etc., will be supplied and should be fitted.

Replacement of parts must be carried out by a **competent person** approved at the time by the Health and Safety Executive.

Before replacing any parts of the boiler it should be isolated from the mains electric supply and the gas should be turned off at the gas service isolation valve on the boiler, see diagram 10.1.

Unless stated otherwise parts are replaced in the reverse order to removal.

After replacing any parts always test for gas tightness and if necessary carry out functional test of the controls.

Boiler Access

For replacement of parts the front casing and the inner casing panel of the boiler will need to be removed. To remove undo the two screws on the underside of the front casing and lift off. Undo the two screws on the front of the inner front panel and lift off.

The side panels can be hinged sideways and removed to aid replacement of parts.

To hinge a side panel undo and remove the three screws securing each side panel to the boiler, two at the front and one at the top.

13.2 Spark Electrode

For access, refer to section 13.1.
Refer to section 11.2 for removal.

13.3 Igniter Unit

For access, refer to section 13.1.
Remove ignition lead and electrical connections then remove igniter unit by removing two securing screws, see diagram 13.1.

13.4 Ignition Lead

For access, refer to section 13.1.
Refer to diagram 11.4 and 11.5.
Pull the spark plug style connector off the spark electrode and the spade connector connected to the igniter unit.

13.5 Gas Valve

For access, refer to section 13.1.
Refer to section 11.3 for removal of the fan, gas valve and burner assembly.
Before removing the gas valve note its position on the fan.
Remove the three securing screws, which fix the gas valve and plastic swirl plate to the venturi on the fan, see diagram 13.2.

Withdraw the gas valve.
After re-fitting check the combustion CO₂ and adjust if necessary, refer to section 11.

After assembly test for gas tightness and purge in accordance with the current issue of BS6891 or in IE, the current edition of I.S.813 "Domestic Gas Installations".

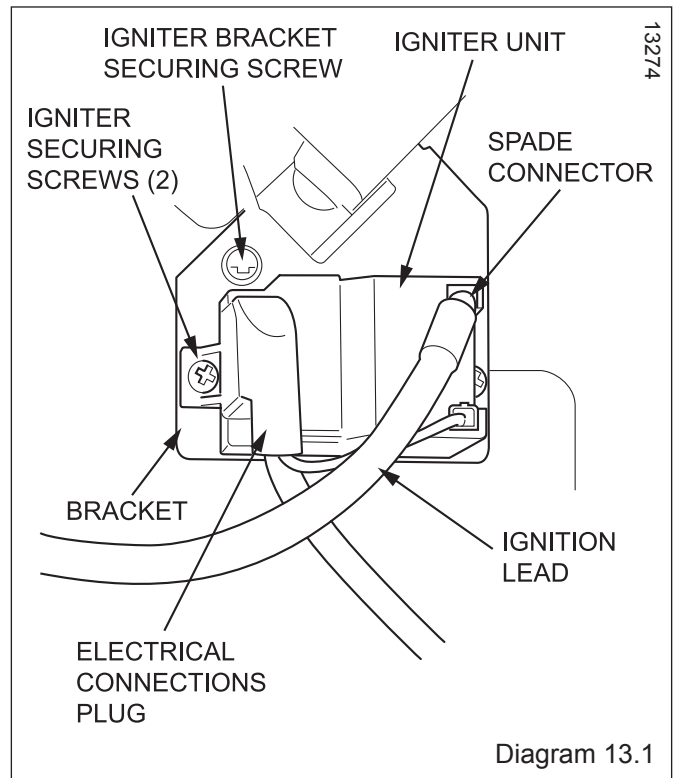

Diagram 13.1

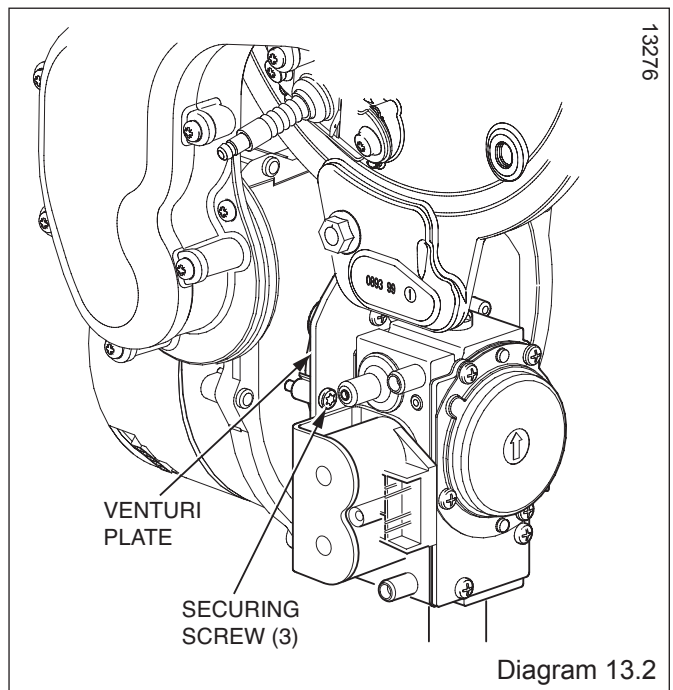

Diagram 13.2

13.6 Fan

For access, refer to section 13.1.
 Refer to section 11.3 for removal of the fan, gas valve and burner assembly.
 Remove the gas valve as described in the relevant parts of section 13.5.
 Remove the venturi plate secured with three screws, see diagram 13.2, and remove the two screws securing the fan to the gas manifold.
 Check the gasket and replace if necessary.
NOTE: The 30hxi and 38hxi fan is secured through an extension piece with two securing screws, check and replace any seals or gaskets if necessary.
 After assembly test for gas tightness and purge in accordance with the current issue of BS6891or in IE, the current edition of I.S.813 "Domestic Gas Installations".

13.7 Burner

For access, refer to section 13.1.
 Refer to section 11.3 for removal of the fan, gas valve and burner assembly.
 Remove the four screws that secure the burner, see diagram 11.6.
NOTE: The burner will require a new gasket when refitted.

13.8 Front Insulation

For access, refer to section 13.1.
 Refer to section 11.3 for removal of the fan, gas valve and burner assembly.
 Remove spark electrode, see section 11.2.
 Remove burner as described in section 13.7, refer to diagram 11.6.
NOTE: The burner will require a new gasket when refitted.

13.9 Rear Insulation

For access, refer to section 13.1.
 Refer to section 11.3 for removal of the fan, gas valve and burner assembly.
 Remove securing screw and washer in the centre of the insulation and withdraw insulation, see diagram 13.4.

13.10 Viewing Window

For access, refer to section 13.1.
 Refer to diagram 13.5.
 Remove circlip.
 Remove steel washer.
 Remove glass.
 Remove fibre washer.
 Replace in reverse order.

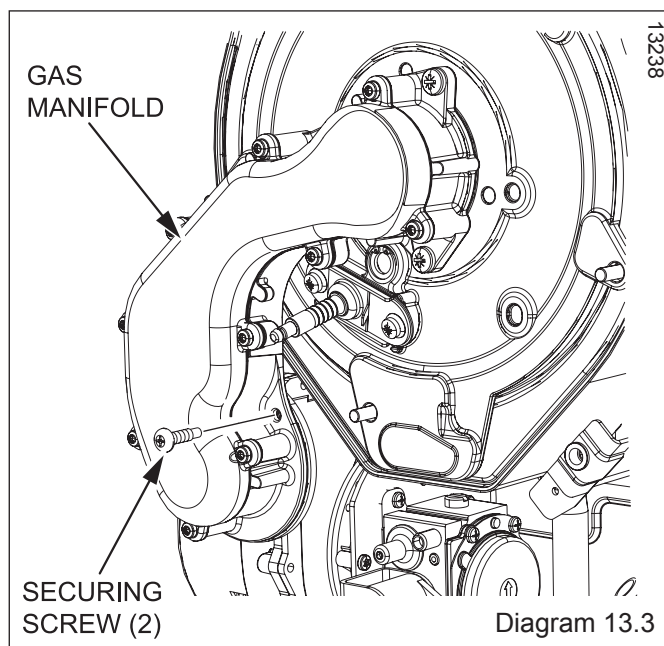

Diagram 13.3

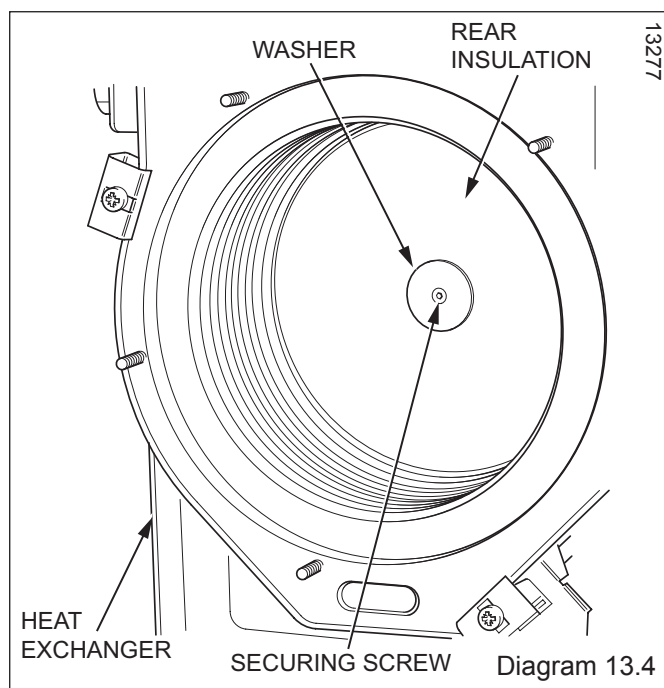

Diagram 13.4

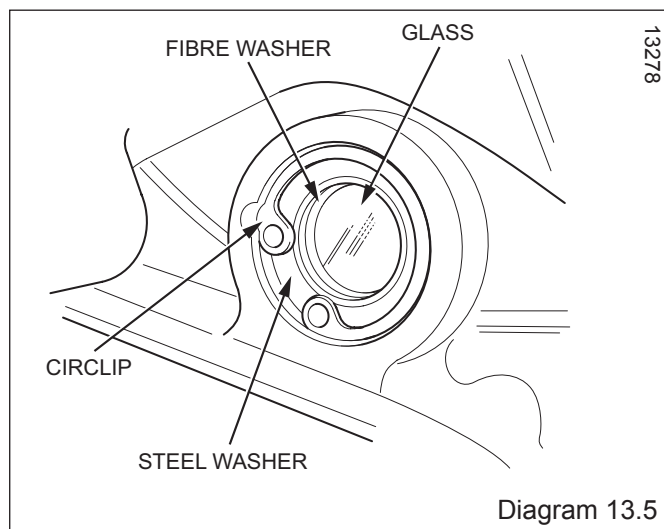

Diagram 13.5

13.11 Condensate Trap and Siphonic Drain

For access, refer to section 13.1.

Refer to diagram 13.6.

Remove the igniter unit as described in section 13.3 to improve accessibility.

Remove the securing clip from the heat exchanger adapter, then disconnect the adapter and flexible hose.

Lift the siphon adapter and hose out of the condensate trap and siphonic drain, do not disconnect the hose.

Disconnect the drain connection.

Slacken to disengage but do not remove the two securing screws.

The condensate trap will contain water, lift taking care not to spill the water.

After replacement and before fitting the adapter fill the trap with water.

Cleaning

Remove the condensate trap as previously described.

Remove the float to clean it.

Remove any solids found.

Flush water through the trap to remove any remaining solids.

Check for any debris in the outlet hose of the condensate drain and clean as necessary.

13.12 Heat Exchanger

Refer to Manual Handling section.

For access, refer to section 13.1.

Refer to section 11.3 for removal of the fan, gas valve and burner assembly.

Drain the boiler.

Remove the securing clip from the heat exchanger adapter then disconnect the adapter and flexible hose.

Undo the two nuts of the flow and return pipes from the heat exchanger.

Move the hoses away from the heat exchanger.

Loosen the three heat exchanger securing screws and clamps (two at the top and one at the bottom) to remove the heat exchanger, see diagram 13.8.

CAUTION: There will be water in the heat exchanger.

Remove condensate pipe connector from bottom of heat exchanger.

Carefully ease heat exchanger out.

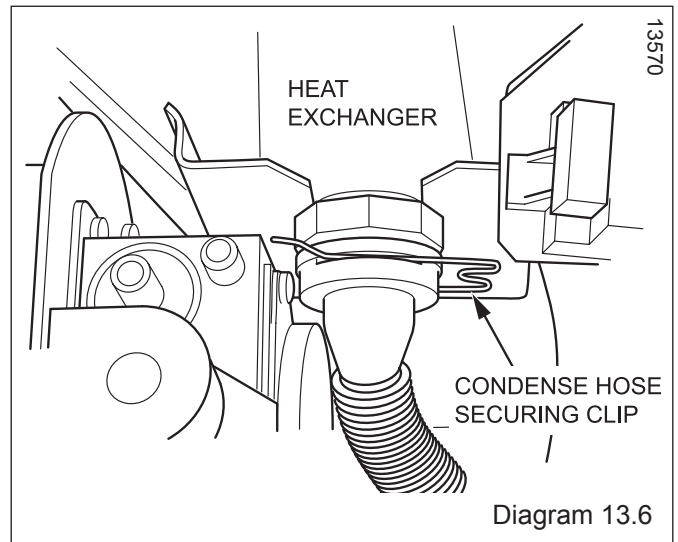

Diagram 13.6

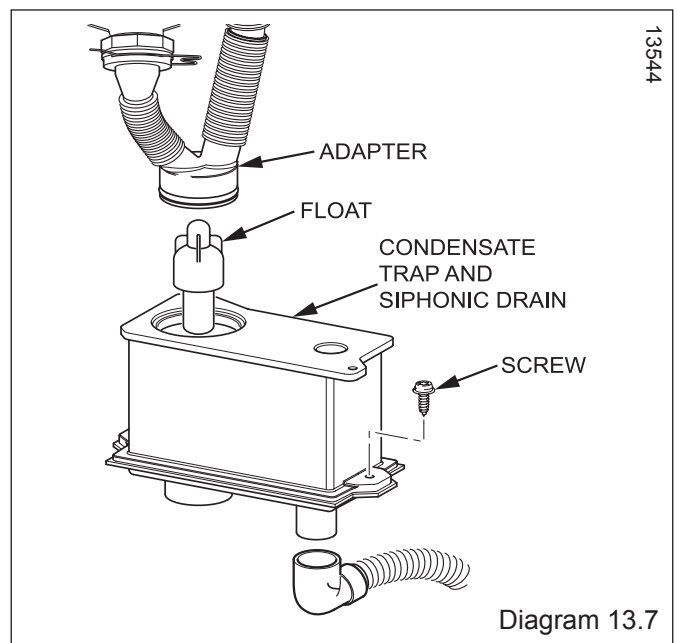

Diagram 13.7

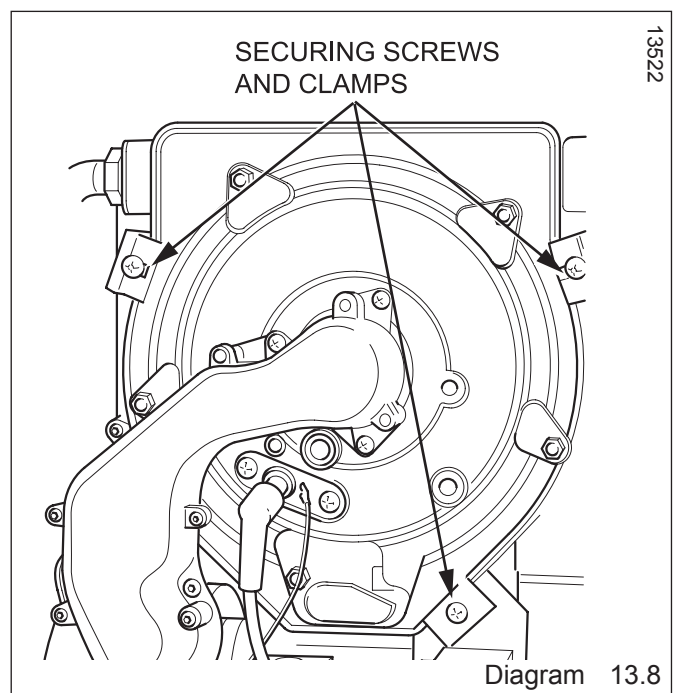

Diagram 13.8

13.13 Flue Hood

For access, refer to section 13.1.
 Remove heat exchanger as described in section 13.12.
 Remove the two securing screws and pull the flue hood down and away from the flue hood bracket and flue elbow, see diagram 13.9.

13.14 Heating Flow Thermistor

For access, refer to section 13.1.
 Refer to diagram 13.10.
 Remove the electrical connections from the thermistor.
 Remove the retaining clip from the flow pipe.
NOTE: When reconnecting, the polarity of the wiring to thermistors is not important.

13.15 Heating Return Thermistor

For access, refer to section 13.1.
 Refer to diagram 13.10.
 Remove the electrical connections from the thermistor.
 Remove the retaining clip from the return pipe.
NOTE: When reconnecting, the polarity of the wiring to thermistors is not important.

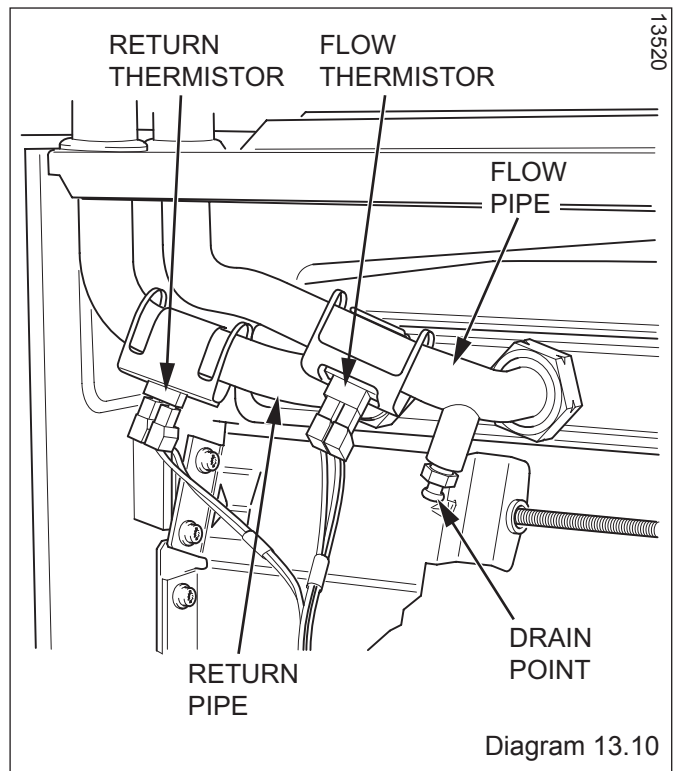
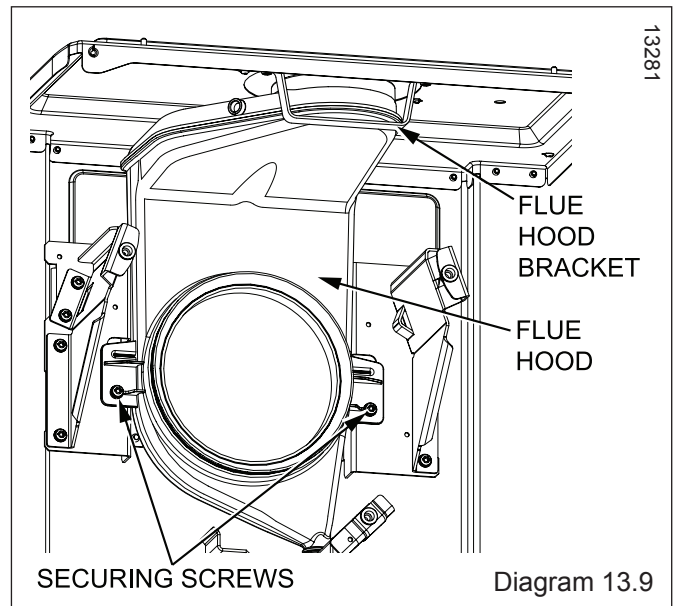

13.16 Access User Interface and Main PCB

For access, refer to section 13.1.
 Remove control box retaining screw, see diagram 13.11.
 Hinge down the control box.
 Release the control box cover by carefully pressing the four retaining latches, see diagram 13.11.

13.17 Main PCB

IMPORTANT: When replacing the board refer to instructions supplied with the replacement.
 For access, refer to section 13.16.
 Remove the electrical connections to the PCB.
 Ease back the four PCB retaining clips and withdraw the PCB from the retaining lugs, see diagram 13.12.
 When refitting the rear panel ensure the leads are not trapped.
 When replacing the board refer to instructions supplied with the replacement.

13.18 User Interface

IMPORTANT: When replacing the board refer to instructions supplied with the replacement.
 Refer to section 13.16 for access.
 Remove main PCB, refer to section 13.17.
 Remove electrical connection.
 Gently ease back the retaining clips, see diagram 13.13.
 Withdraw the board.

13.19 Fuse, Main PCB - Control Box

For access, refer to section 13.16.
 The fuse is located at top left hand side of the PCB, see diagram 13.12.

13.20 Control Box

For access, refer to section 13.16.
 Remove relevant plugs and connectors, refer to wiring diagram 12.4.
 Withdraw grommets and leads so they are hanging loose.
 Unthread the retaining cord and remove the control box by drawing it outwards away from its retaining slots, see diagram 13.11.

13.21 Inner Casing Panel Seal

For access, refer to section 13.1.
 Refer to diagram 11.8.
 Remove the inner casing panel.
 To replace remove the old seal, thoroughly clean the casing surfaces. Fit the new seal, it is supplied to the correct length.
 Refit the inner casing panel.
NOTE: Ensure the seal is fitted correctly giving an airtight joint.

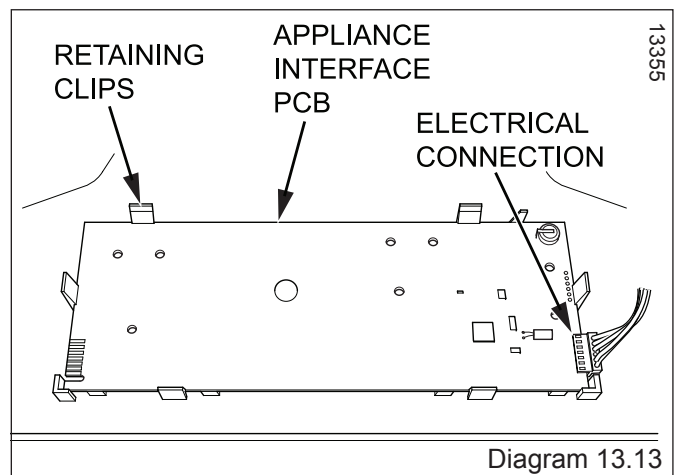
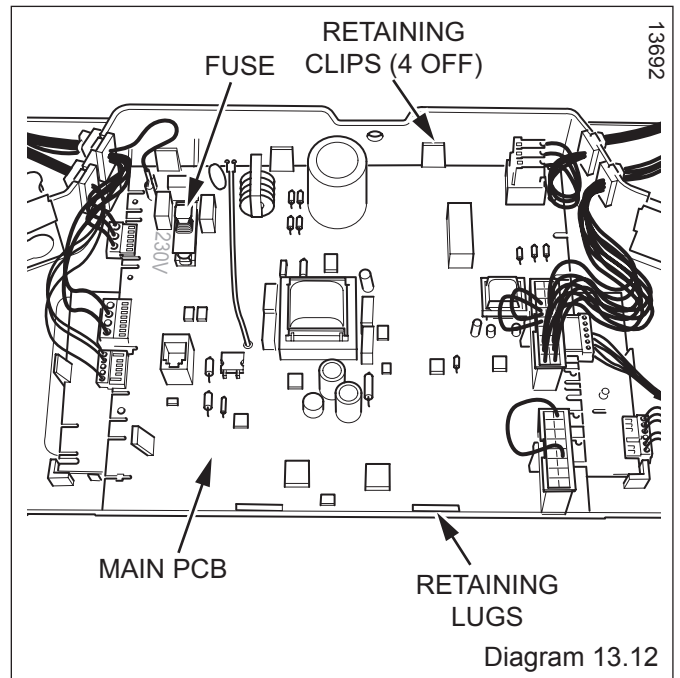
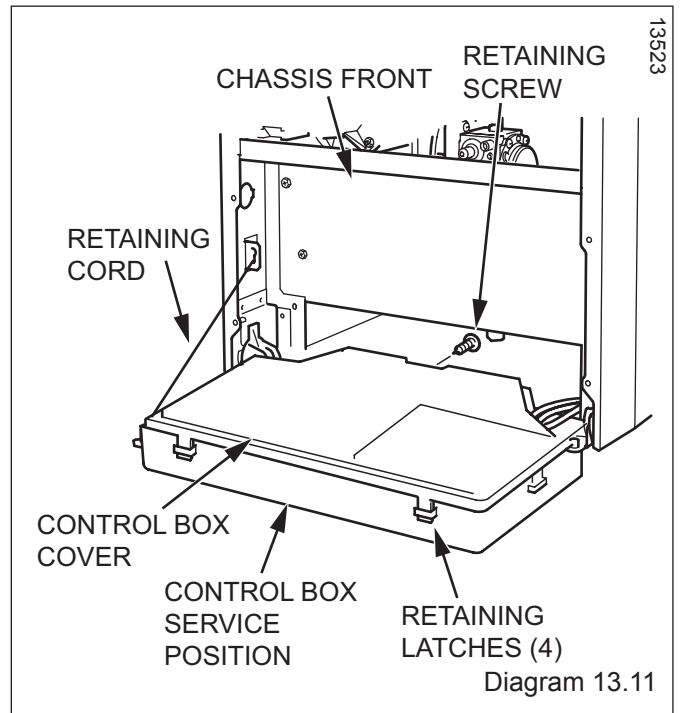

14 Spare Parts

When ordering spare parts, contact Glow-worm's own service organisation using the telephone number on the inside front cover of this booklet. Please quote the name of the appliance and serial number, to be found on the data label. If ordering from British Gas also quote the G.C. number of the part.

Key No.	Part No.	Description	GC Part No.
1	2000802463	Burner - 12, 15, 18hxi	E84021
1	2000802662	Burner - 24, 30, 38hxi	H36356
2	801655	Igniter	E84015
3	0020023825	Main P.C.B.	H42783
4	0020037309	Fan	H53083
5	0020038061	User Interface	H52596
6	2000802664	Gas valve - 12, 15, 18, 24, 30hxi	E84004
6	0020018823	Gas valve - 38hxi	*****
7	0020020781	NTC	720340
8	2000802462	Electrode	H53089
9	801635	Burner Door Seal Kit	E85008

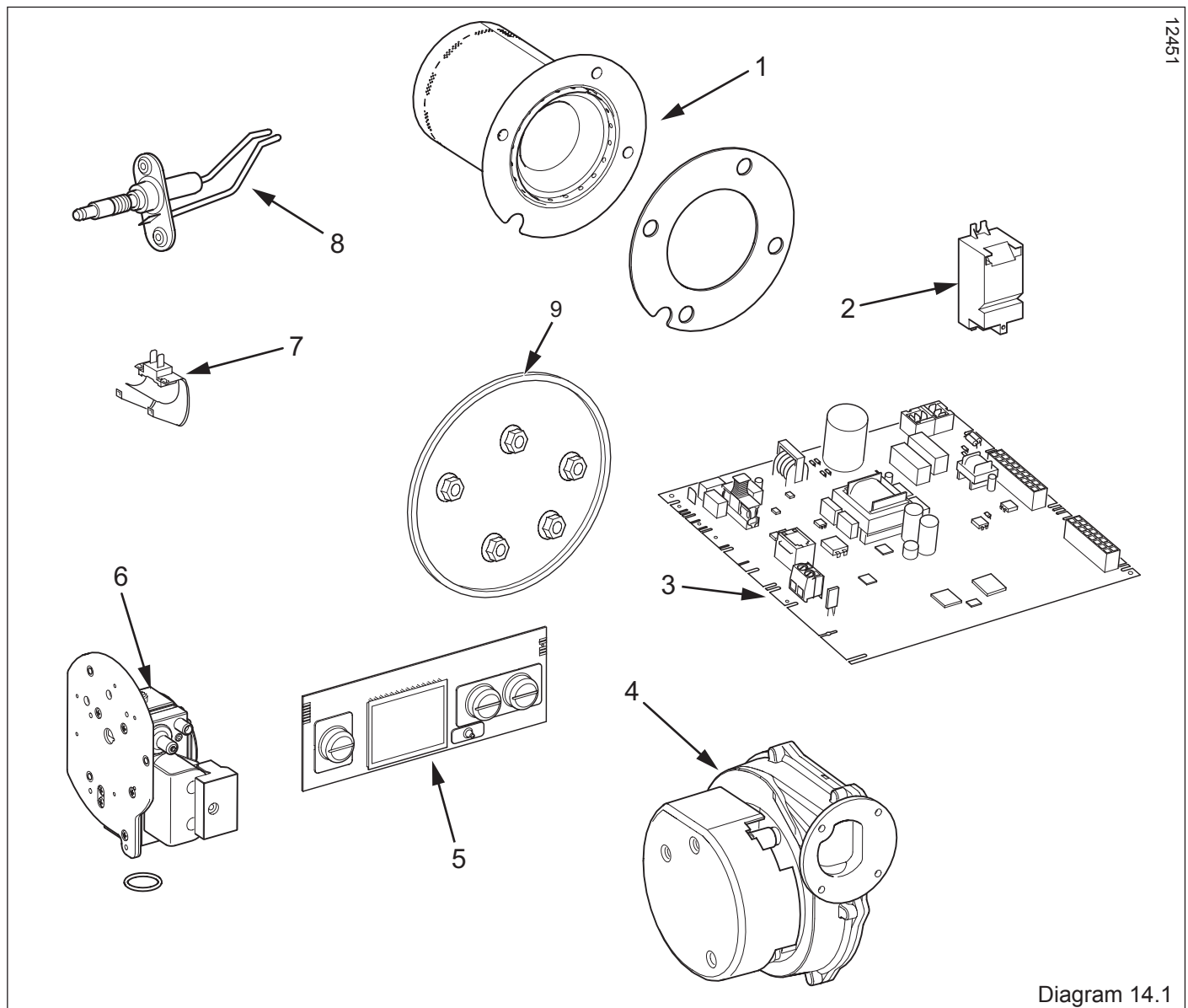

15 Manual Handling

IMPORTANT. With regards to the Manual Handling Operations, 1992 Regulations, the following lift operation exceeds the recommended weight for a one man lift.

General recommendations when handling

Clear the route before attempting the lift.

Ensure safe lifting techniques are used – keep back straight – bend using legs. Keep load as close to body as possible. Do not twist – reposition feet instead. If 2 persons performing lift, ensure co-ordinated movements during lift. Avoid upper body/top heavy bending - do not lean forward/sideways. Recommend wear suitable cut resistant gloves with good grip to protect against sharp edges and ensure good grip.

Always use assistance if required.

Removal of carton from delivery van

Recommend 2 person lift or 1 person with use of sack truck. If 1 person is performing lift, straddle the load, tilt and place carton into position on truck. Recommend secure appliance onto truck with suitable straps. Ensure safe lifting techniques are used – keep back straight – bend using legs. Keep load as close to body as possible. If 2 persons performing lift, ensure co-ordinated movements during lift. Always use assistance if required.

Carriage of carton from point of delivery to point of installation – ground floor.

Recommend 2 person lift or 1 person with use of sack truck. If 1 person is performing lift, straddle the load, tilt and place carton into position on truck. Recommend secure appliance onto truck with suitable straps. Ensure safe lifting techniques are used – keep back straight – bend using legs. Keep load as close to body as possible. If 2 persons performing lift, ensure co-ordinated movements during lift. Clear the route before attempting the lift. If removing boiler from truck straddle the load and tilt forwards to facilitate secure grip. Ensure safe lifting techniques are used – keep back straight – bend using legs. Do not twist – reposition feet instead. Take care to avoid trip hazards, slippery or wet surfaces and when climbing steps and stairs. Always use assistance if required.

Carriage of carton from point of delivery to point of installation – first or higher floor, cellar.

Recommend 2-person lift or 1 person with use of sack truck. If 1 person is performing lift, straddle the load, tilt and place carton into position on truck. Recommend secure appliance onto truck with suitable straps. Ensure safe lifting techniques are used – keep back straight – bend using legs. Keep load as close to body as possible. If 2 persons performing lift, ensure co-ordinated movements during lift. Avoid upper body/top heavy bending - do not lean forward/sideways. Clear the route before attempting the lift. If removing boiler from truck straddle the load and tilt forwards to facilitate secure grip. Ensure safe lifting techniques are used – keep back straight – bend using legs. Do not twist – reposition feet instead. Take care to avoid trip hazards, slippery or wet surfaces and when climbing steps and stairs. Always use assistance if required.

Carriage of carton from point of delivery to point of installation – roofspace.

Recommend 2-person lift. Ensure co-ordinated movements during lift. Avoid upper body/top heavy bending - do not lean forward/sideways. Clear the route before attempting the lift. Take care to avoid trip hazards, slippery or wet surfaces and when climbing steps and stairs. When transferring appliance into roofspace, recommend 1 person to be in roofspace to receive the appliance and other person to be below to pass up and support appliance. Ensure safe lifting techniques are used – keep back straight – bend using legs. Keep load as close to body as possible. Always use assistance if required. It is assumed safe access, flooring and adequate lighting are provided in the roof space. It is recommended a risk assessment of the roof space area be carried out before moving the appliance into the area to take into account access, stability of flooring, lighting and other factors, and appropriate measures taken.

Unpacking of appliance from carton.

Recommend 2 persons unpack appliance from carton. Always keep working area clear. Cut the carton straps, lift carton up and slide over polystyrene end packs. Remove top polystyrene pack with fittings.

Positioning of Appliance for Final Installation – no obstructions.

Recommend 2 persons lift appliance to position into place. Fit bracket securely onto wall before lifting appliance into position. Obtain firm grip on front and sides of appliance, lift upwards, ensure stable balance achieved and lift upwards to position in place on bracket. Ensure safe lifting techniques are used – keep back straight – bend using legs - when lifting load from floor level. Do not twist – reposition feet instead. Keep boiler as close as possible to body throughout lift to minimise strain on back. Ensure co-ordinated movements to ensure equal spread of weight of load. Always use assistance if required. Recommend wear suitable cut resistant gloves with good grip to protect against sharp edges and ensure good grip when handling appliance.

Positioning of Appliance for Final Installation – above worktop, foreseeable obstructions etc.

Recommend 2 persons lift appliance to position into place. Fit bracket securely onto wall before lifting appliance into position. Obtain firm grip on front and sides of appliance, lift upwards, onto worktop if practicable. Ensure stable balance achieved and lift upwards to position in place on bracket. If 2 persons positioning onto bracket obtain firm grip at front and sides/base of boiler. Ensure co-ordinated movements during 2 person lifts to ensure equal spread of weight of load. Ensure safe lifting techniques are used – keep back straight – bend using legs - when lifting load from floor level. Do not twist – reposition feet instead. Keep boiler as close as possible to body throughout lift to minimise strain on back. Avoid upper body/top heavy bending - do not lean forward/sideways. Always use assistance if required. Recommend wear suitable cut resistant gloves with good grip to protect against sharp edges and ensure good grip when handling appliance.

Positioning of Appliance for Final Installation – within compartment etc. restricting installation.

Recommend 2 persons lift appliance to position into place, space permitting. Fit bracket securely onto wall before lifting appliance into position. Obtain firm grip on front and sides of appliance, lift upwards, onto worktop if practicable. Ensure stable balance achieved and lift upwards to drop into place onto bracket. If 2 persons positioning onto bracket obtain firm grip at front and sides/base of boiler. Ensure co-ordinated movements during 2 person lifts to ensure equal spread of weight of load. If 1 person positioning onto bracket recommend obtain firm grip supporting base of boiler. Ensure safe lifting techniques are used – keep back straight – bend using legs - when lifting load from floor level. Do not twist – reposition feet instead. Keep boiler as close as possible to body throughout lift to minimise strain on back. Always use assistance if required. Recommend wear suitable cut resistant gloves with good grip to protect against sharp edges and ensure good grip when handling appliance.

Positioning of Appliance for Final Installation – in roof space restricting installation.

Recommend 2 persons lift appliance to position into place, space permitting. Fit bracket securely onto wall before lifting appliance into position. Obtain firm grip on front and sides of appliance, lift upwards, ensure stable balance achieved and lift upwards to drop into place onto bracket. If 2 persons positioning onto bracket obtain firm grip at front and sides/base of boiler. Ensure co-ordinated movements during 2 person lifts to ensure equal spread of weight of load. If 1 person positioning onto bracket recommend obtain firm grip supporting base of boiler. Ensure safe lifting techniques are used - keep back straight – bend using legs - when lifting load from floor level. Do not twist – reposition feet instead. Keep boiler as close as possible to body throughout lift to minimise strain on back. Always use assistance if required. Recommend wear suitable cut resistant gloves with good grip to protect against sharp edges and ensure good grip when handling appliance. It is recommended a risk assessment of the roof space area be carried out before moving the appliance into the area to take into account access, stability of flooring, lighting and other factors, and appropriate measures taken.

Glow•worm

EC declaration of conformity

Name and Address of the manufacturer:	Glow-worm Nottingham Road Belper Derbyshire DE56 1JT
Identification of product:	Glow worm :- Ultracom Series Condensing Wall Hung Heating Only Boilers
Appliance type:	Ultracom 12hxi, 15hxi, 18hxi, 24hxi, 30hxi & 38hxi

The appliance types satisfy the essential requirements of the relevant directives and Standards:

90/396/EEC including amendments "Directive on the approximation of the law of the member states relating to appliances burning gaseous fuels"	Designed and built to CE-type examination certificate: PIN no: 87BO41
92/42/EEC including amendments "Directive of efficiency relating to boiler burning gaseous fuels"	Designed and built according to European Standards:
73/23/EEC including amendments "Directive on the harmonization of the laws of Member States relating to electrical equipment designed for use within certain voltage limits"	EN 483 EN 677 EN 60335-1 EN 60529 EN 50165 EN 55014 EN 61000-3-2 EN 61000-3-3
89/336/EEC including amendments "Directive on the approximation of the law of the member states relating to electromagnetic compatibility"	

Any change to the appliance and/or any use not according to the instructions will lead to the invalidation of this Declaration of Conformity

Belper, October 2006

(place, date)



Program Manager
S. Keeton

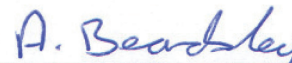

Certification Manager
A. Beardsley

Glow-worm – Nottingham Road – Belper – Derbyshire – DE56 1JT

Please affix the label positioned on the top panel of your boiler over this area.



PEEL OFF

COMMISSIONING CHECKLIST GAS BOILER SYSTEM

This Commissioning Checklist is to be completed in full by the competent person who commissioned the boiler as a means of demonstrating compliance with the appropriate Building Regulations and then handed to the customer to keep for future reference.

Failure to install and commission this equipment to the manufacturer's instructions will invalidate the warranty but does not affect statutory rights.

Customer Name _____ Telephone Number _____
 Address _____
 Commissioned by (print name) _____ Engineer ID Number _____
 Company Name _____ Telephone Number _____
 Company Address _____ Commissioning Date _____

To be completed by the customer on receipt of a Building Regulations Compliance Certificate*:

Building Regulations Notification Number (if applicable) _____

CONTROLS Tick the appropriate boxes

Time and Temperature Control to Heating	Room Thermostat and Programmer/Timer <input type="checkbox"/>	Programmable Room Thermostat <input type="checkbox"/>	Load/Weather Compensation <input type="checkbox"/>	Optimum Start Control <input type="checkbox"/>
Time and Temperature Control to Hot Water	Cylinder Thermostat and Programmer/Timer <input type="checkbox"/>		Combination Boiler <input type="checkbox"/>	
Heating Zone Valves			Fitted <input type="checkbox"/>	Not Required <input type="checkbox"/>
Hot Water Zone Valves			Fitted <input type="checkbox"/>	Not Required <input type="checkbox"/>
Thermostatic Radiator Valves			Fitted <input type="checkbox"/>	Not Required <input type="checkbox"/>
Automatic Bypass to System			Fitted <input type="checkbox"/>	Not Required <input type="checkbox"/>
Boiler Interlock				Provided <input type="checkbox"/>

ALL SYSTEMS

The system has been flushed and cleaned in accordance with BS7593 and boiler manufacturer's instructions Yes

What system cleaner was used? _____

What inhibitor was used? _____ Quantity litres

CENTRAL HEATING MODE Measure and Record:

Gas Rate m³/hr OR ft³/hr
 Burner Operating Pressure (if applicable) mbar OR Gas Inlet Pressure mbar
 Central Heating Flow Temperature °C
 Central Heating Return Temperature °C

COMBINATION BOILERS ONLY

Is the installation in a hard water area (above 200ppm)? Yes No

If yes, has a water scale reducer been fitted? Yes No

What type of scale reducer has been fitted? _____

DOMESTIC HOT WATER MODE Measure and Record:

Gas Rate m³/hr OR ft³/hr
 Burner Operating Pressure (at maximum rate) mbar OR Gas Inlet Pressure (at maximum rate) mbar
 Cold Water Inlet Temperature °C
 Hot water has been checked at all outlets Yes Temperature °C
 Water Flow Rate l/min

CONDENSING BOILERS ONLY

The condensate drain has been installed in accordance with the manufacturer's instructions and/or BS5546/BS6798 Yes

ALL INSTALLATIONS

If required by the manufacturer, record the following CO₂ % OR CO ppm OR CO/CO₂ Ratio

The heating and hot water system complies with the appropriate Building Regulations Yes

The boiler and associated products have been installed and commissioned in accordance with the manufacturer's instructions Yes

The operation of the boiler and system controls have been demonstrated to and understood by the customer Yes

The manufacturer's literature, including Benchmark Checklist and Service Record, has been explained and left with the customer Yes

Commissioning Engineer's Signature _____

Customer's Signature _____

(To confirm satisfactory demonstration and receipt of manufacturer's literature)

*All installations in England and Wales must be notified to Local Authority Building Control (LABC) either directly or through a Competent Persons Scheme. A Building Regulations Compliance Certificate will then be issued to the customer.

©Heating and Hotwater Industry Council (HHIC)



SERVICE INTERVAL RECORD

It is recommended that your heating system is serviced regularly and that you complete the appropriate Service Interval Record Below .

Service Provider. Before completing the appropriate Service Interval Record below, please ensure you have carried out the service as described in the boiler manufacturer's instructions. Always use the manufacturer's specified spare part when replacing all controls.

SERVICE 1 Date

Energy Efficiency Checklist completed? Yes No

Engineer Name _____

Company Name _____

Telephone Number _____

Engineer ID Number _____

Comments _____

Signature _____

SERVICE 2 Date

Energy Efficiency Checklist completed? Yes No

Engineer Name _____

Company Name _____

Telephone Number _____

Engineer ID Number _____

Comments _____

Signature _____

SERVICE 3 Date

Energy Efficiency Checklist completed? Yes No

Engineer Name _____

Company Name _____

Telephone Number _____

Engineer ID Number _____

Comments _____

Signature _____

SERVICE 4 Date

Energy Efficiency Checklist completed? Yes No

Engineer Name _____

Company Name _____

Telephone Number _____

Engineer ID Number _____

Comments _____

Signature _____

SERVICE 5 Date

Energy Efficiency Checklist completed? Yes No

Engineer Name _____

Company Name _____

Telephone Number _____

Engineer ID Number _____

Comments _____

Signature _____

SERVICE 6 Date

Energy Efficiency Checklist completed? Yes No

Engineer Name _____

Company Name _____

Telephone Number _____

Engineer ID Number _____

Comments _____

Signature _____

SERVICE 7 Date

Energy Efficiency Checklist completed? Yes No

Engineer Name _____

Company Name _____

Telephone Number _____

Engineer ID Number _____

Comments _____

Signature _____

SERVICE 8 Date

Energy Efficiency Checklist completed? Yes No

Engineer Name _____

Company Name _____

Telephone Number _____

Engineer ID Number _____

Comments _____

Signature _____

SERVICE 9 Date

Energy Efficiency Checklist completed? Yes No

Engineer Name _____

Company Name _____

Telephone Number _____

Engineer ID Number _____

Comments _____

Signature _____

SERVICE 10 Date

Energy Efficiency Checklist completed? Yes No

Engineer Name _____

Company Name _____

Telephone Number _____

Engineer ID Number _____

Comments _____

Signature _____

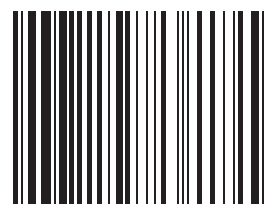

0020107233

Subject to engineering changes

0020107233_00 - 06/11

GLOW-WORM

Nottingham Road,
Belper, Derbyshire.
DE56 1JT

Because of our constant endeavour for
improvement, details may vary slightly
from those shown in these instructions.

Glow•worm

www.glow-worm.co.uk