

## Installation and Instructions for Use

# Outdoor Sensor

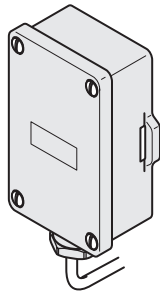

To be left with the user

[www.glow-worm.co.uk](http://www.glow-worm.co.uk)

# General

**Customer Service:** 01773 828100 **Technical Helpline:** 01773 828300  
**General and Sales enquiries:** Tel. 01773 824639 Fax: 01773 820569

Benchmark places responsibilities on both manufacturers and installers. The purpose is to ensure that customers are provided with the correct equipment for their needs, that it is installed, commissioned and serviced in accordance with the manufacturer's instructions by competent persons and that it meets the requirements of the appropriate Building Regulations. The Benchmark Checklist can be used to demonstrate compliance with Building Regulations and should be provided to the customer for future reference.

Installers are required to carry out installation, commissioning and servicing work in accordance with the Benchmark Code of Practice which is available from the Heating and Hot water Industry Council who manage and promote the Scheme.

Visit [www.centralheating.co.uk](http://www.centralheating.co.uk) for more information.



Please read these instructions and follow them carefully for the safe and economical use of your boiler. On completion of installation leave the instructions with the user.

<b>Contents</b>	<b>Page</b>
General information	3
Kit contents	5
<b>Section (A)</b>	
Installer important information	6
Outdoor sensor location	7
Installation	9
<b>Section (B)</b>	
Configuring the outdoor sensor	13
<b>Section (C)</b>	
Configuring the outdoor sensor with external Glow-worm Climapro or Climastat controls	22

## General

The outdoor sensor enables weather compensation by providing an advanced level of modulation, achieving an additional level of efficiency. This control compensates for the outside temperature by modulating the lower radiator temperatures in warmer weather and higher radiator temperatures in colder weather.

The outdoor temperature compensation is easily configured using either the boilers interface controls or the interface of an external Glow-worm Climastat or Climapro room control (if fitted). Optimum comfort and efficiency is achieved when used in conjunction with a Climastat or Climapro (in modulating mode). The outdoor sensor can also be used with a conventional on/off thermostat.

# General Information

---

The installation and the commissioning of the Outdoor sensor has to be carried out by a competent person in accordance with the current regulations.

The maintenance and the repairing of the Outdoor sensor will also require the use of a competent person.

## Documents

Please keep these instructions as well as any documents enclosed, for future reference.

We accept no liability in case of damage due to the non-compliance of these instructions.

## Application

The outdoor sensor controls the heating demand for the appliance, which is dependant on the outdoor temperature.

Any other use is considered as inappropriate and is forbidden.

The user will be responsible for any damage caused by any other use.

## Servicing

Clean the case of the outdoor sensor with damp soapy cloth, make sure that no water goes inside the outdoor sensor.

Do not use any abrasive cleaning product as they could damage the housing or plastic case.

### Recycling

The Outdoor Sensor comprises of many recyclable parts and should be disposed of according to the current WEEE regulations.

The packaging should also disposed of according to the current regulations.

**Kit contents** Refer to diagram 1.  
Kit part number 0020040796.

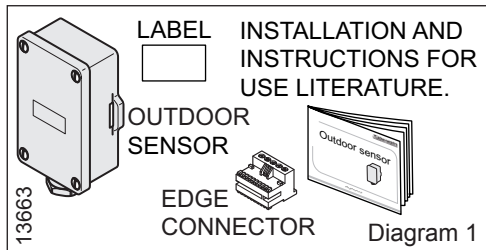

### Safety instructions and regulations

This outdoor sensor is tested and certificated for safety and performance. It is, therefore, important that no alteration is made to the outdoor sensor, without permission, in writing, from Glow-worm.

Any alteration not approved by Glow-worm, could invalidate the certification, appliance warranty and may also infringe the current issue of the statutory requirements.

### Safety instructions

#### WARNING:

Incorrect installation can cause electric shock and damage to the outdoor sensor.

# (A) Installer important information

---

## Regulations

When installing and commissioning the outdoor sensor, the regulations below shall be observed in their current version.

Where no specific instructions are given, reference should be made to the relevant British Standard Code of Practice.

Where no British Standard exists, materials and equipment should be fit for their purpose and of suitable quality and workmanship.

The installation of this outdoor sensor must be carried out by a competent person in accordance the rules in force in the countries of destination. Manufacturer's instructions must not be taken as overriding statutory requirements.

## Mandatory WARNING for EEC countries

The CE mark on this appliance shows compliance with:

Directive 89/336/EEC on the approximation of the Laws of the Member States relating to electromagnetic compatibility.

Directive 73/23/EEC on the harmonisation of the Laws of the Member States relating to electrical equipment designed for use within certain voltage limits.

### Technical data

Power supply	5V
Power consumption	<10mW
Cable	2 core insulated for outdoor use
Electrical protection	IP 44
Electrical category	Protection class II

### Dimensions:

Height 32mm	Width 46mm
Depth 86mm	(including gland)

### Outdoor sensor location

Refer to diagram 2.

The outdoor sensor should be placed on an external North/North-West facing wall of the house.

For optimal reading of the outdoor temperature, the device should be placed about  $\frac{2}{3}$  up the wall for buildings of 3 floors or less.

For higher buildings, the recommended position is between the 2nd and 3rd floors. It should not be installed sheltered from wind or draughts, nor directly exposed to the sun.

The sensor should be placed at least 1 metre from openings and away from permanent or occasional emissions of hot air.

# (A) Outdoor sensor location

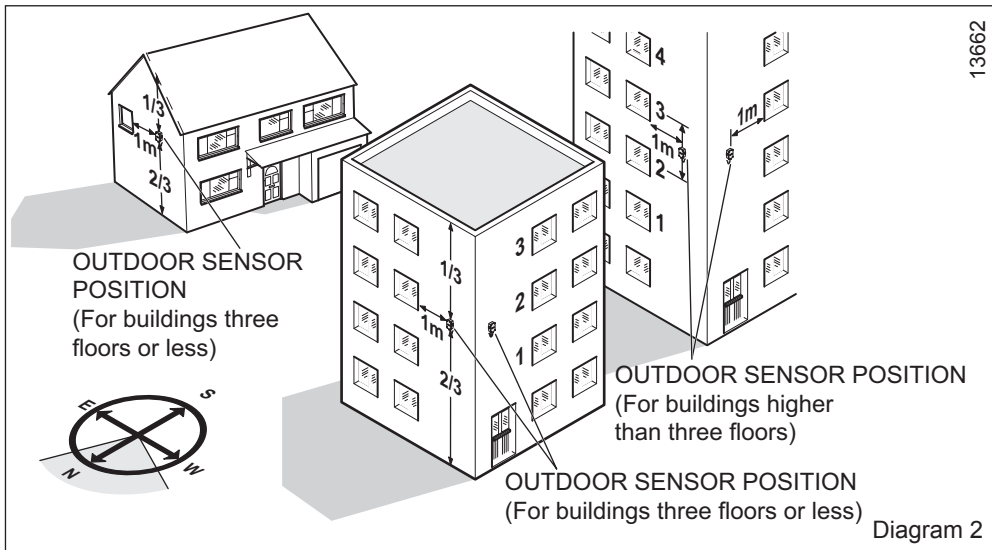

# (A) Installation

Refer to diagram 3. Remove the front cover, seal and electrical sealing gland.

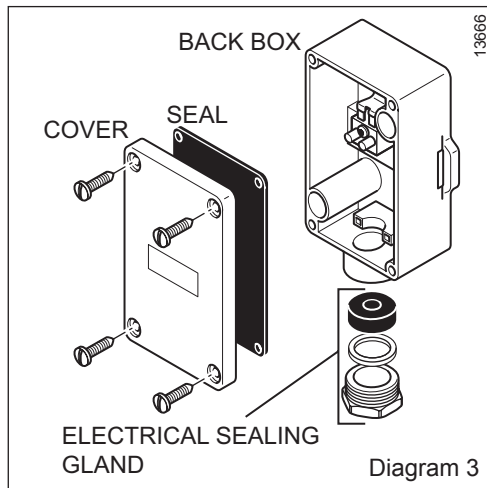

Choose the location of the outdoor sensor, refer to page 6. Fit the back box to the wall, see diagram 4.

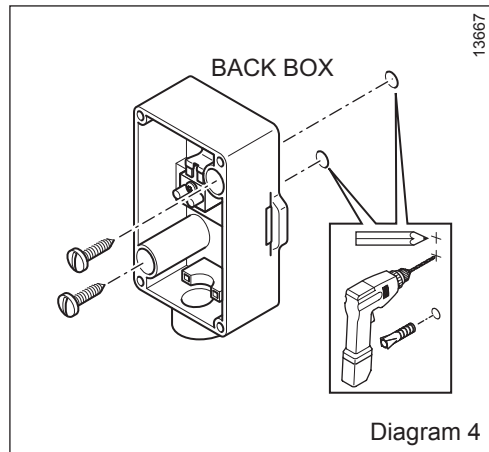

## (A) Installation

**WARNING:** Isolate the boiler from the electrical supply. A competent person should make the electrical connections.

Use a cable that complies with the specifications given in Technical data, page 7. Route the cable from the outdoor sensor to the boiler electrical cartridge at the boiler, refer to the literature supplied with your boiler for location and access.

Refer to diagram 5, thread the cable through the electrical sealing gland. Connect the cable to the electrical connection, polarity is not important. Fit the sealing gland, this secures the cable and gives a water tight seal. Connect the cable to OTC1 and OTC2 connection in the electrical cartridge at the boiler, polarity is not important, refer to diagram 6.

**Note:** Ultracom hxi & Flexicom hx open vent system models only. The edge connector will need to be fitted, see diagram 7.

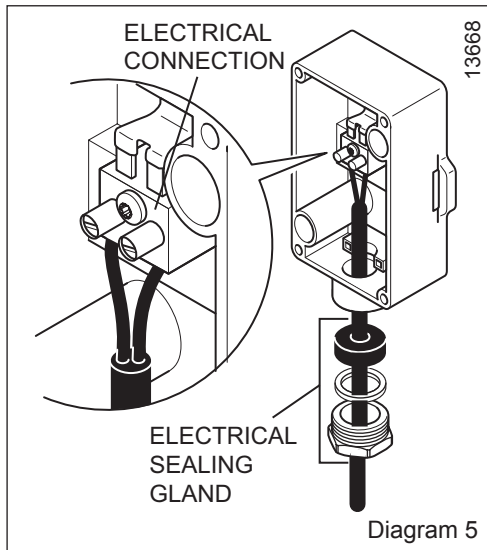

# (A) Installation

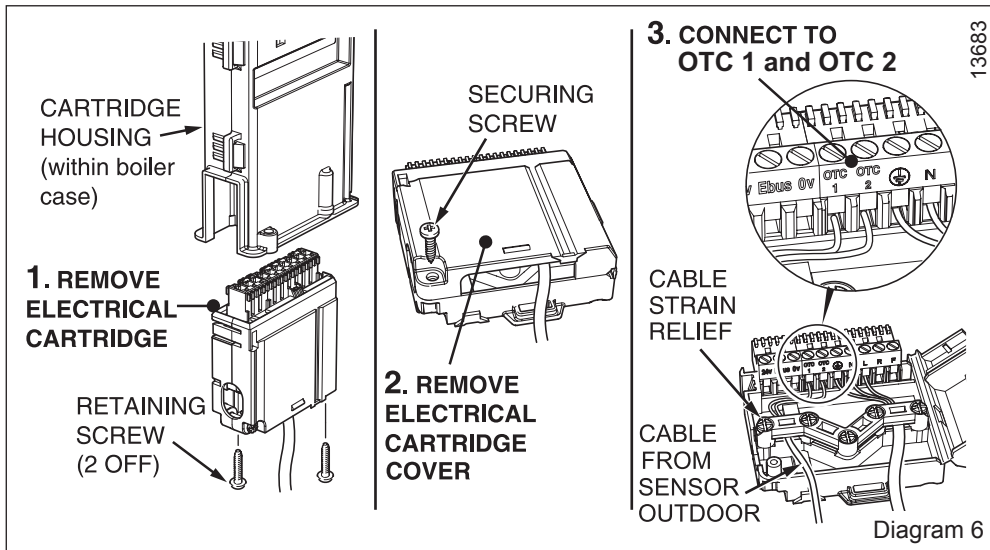

# (A) Installation

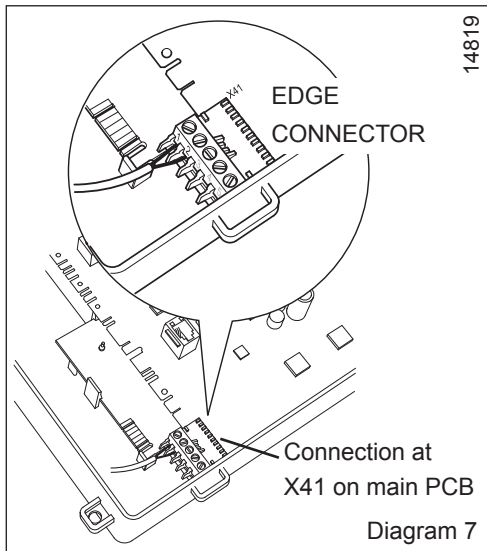

Refer to diagram 8, fit and secure the seal and cover.

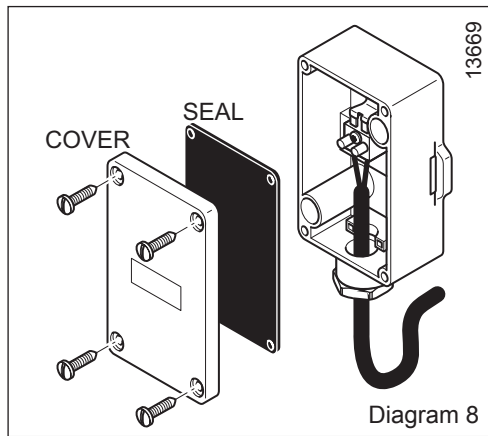

## (B) Configuring the Outdoor Sensor

Configuration of the outdoor sensor is achieved through the Appliance interface controls on the boiler, see diagram below.

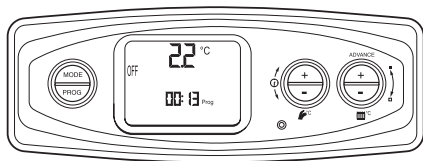

Appliance interface controls

**NOTE:** If a Glow-worm Climapro or Glow-worm Climastat is fitted, please refer to section C to configure the outdoor sensor.

Glow-worm Climapro



Glow-worm Climastat



## (B) Configuring the Outdoor Sensor

### Choosing and Setting Sensor Heating Curve.

A gradient must be chosen from the range shown on page 17, labelled 0-9.

The decision as to which heating curve should be used is based on two factors:

1. The average minimum outside temperature of the region.
2. The maximum temperature which the heating appliance can provide.

**NOTE:** Consider the level of heat loss in comparison to typical UK heat loss e.g. (double glazing, loft insulation and cavity wall insulation).

### Method with example.

The following example describes the process. The temperatures quoted should be substituted with real values to find the required heating curve.

1. Select the average minimum outdoor temperature expected in your region where the sensor will be installed. For example at the peak of winter the temperature may drop to  $-5^{\circ}\text{C}$ . This would be the value selected from the Outdoor temperature  $^{\circ}\text{C}$  axis.
2. Select the maximum output temperature of the heating appliance from the Heating flow temperature ( $^{\circ}\text{C}$ ) axis. For example this could be  $82^{\circ}\text{C}$ .

## (B) Configuring the Outdoor Sensor

Plot these two points onto the chart. They intersect the gradient curve labelled 6. The value 6 would be entered into the boiler via the diagnostic menu d.45.

Refer to the following diagrams and text to do this.

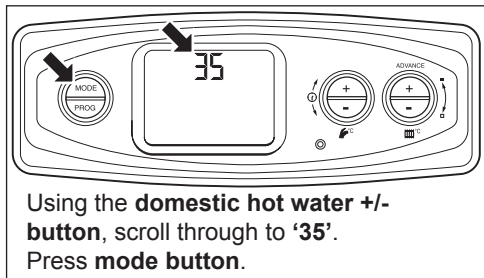
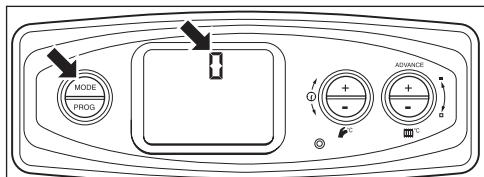
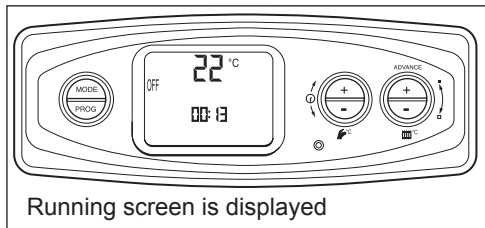

## (B) Configuring the Outdoor Sensor

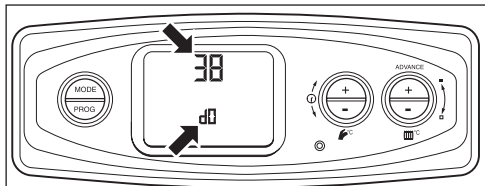

On screen are two blocks of information, 'd0' in the lower part of the screen in small text. In the top centre of the screen, where the pressure or temperature is normally shown, is displayed the **heating part load** for the appliance (it will be different for various kW output boilers). For example this could be '18', '38'.

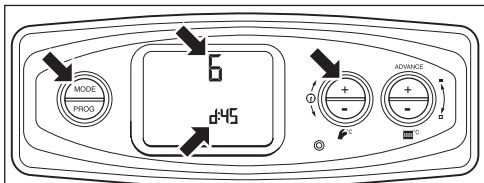

Using the **domestic hot water +/- button**, scroll through until 'd45' is shown in small text. Press **mode button** once. The large number on the screen then starts flashing. Using the **domestic hot water +/- button** change the value to '6'. Press **mode button** once.

## (B) Configuring the Outdoor Sensor

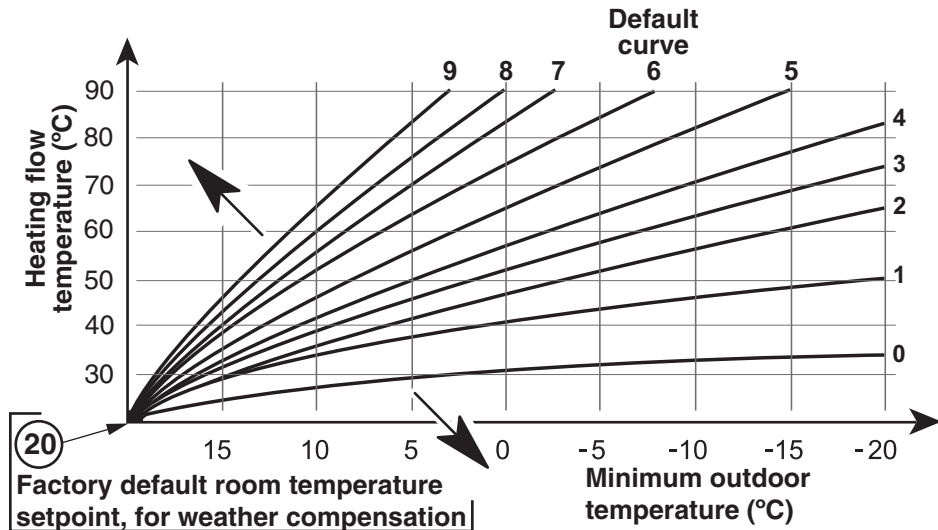

13664

## (B) Configuring the Outdoor Sensor

### Adjusting room temperature set point.

By default the outdoor sensor aims to provide a room ambient temperature of 20°C. In some situations it may be necessary to have a lower or higher ambient room temperature the adjustment is made in terms of an offset value, which is entered into the appliance via diagnostic menu 'd.46'. Refer to the following diagrams and text to do this.

### Method with example.

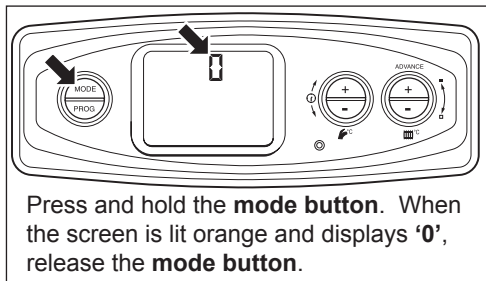
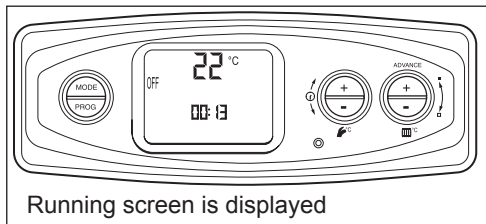

## (B) Configuring the Outdoor Sensor

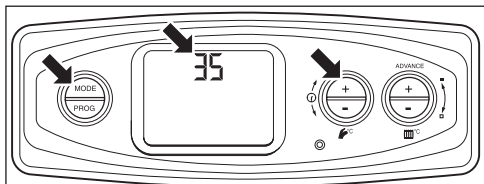

Using the **domestic hot water +/- button**, scroll through to '35'. Press **mode button**.

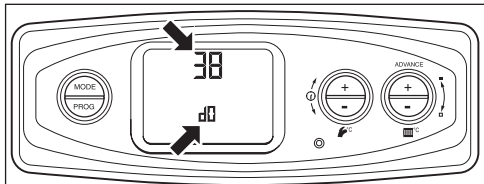

On screen are two blocks of information, 'd0' in the lower part of the screen in small text. In the top centre of the screen, where the pressure or temperature is normally shown, is displayed the **heating part load** for the appliance (it will be different for various kW output boilers). For example this could be '18', '38'.

## (B) Configuring the Outdoor Sensor

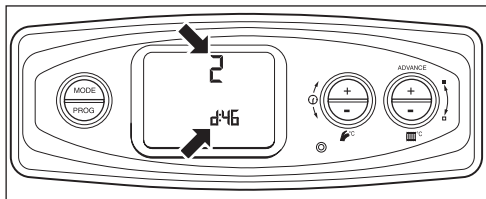

For example:

10°C = offset -10

20°C = offset 0

30°C = offset 10

If extra heating comfort is required, the room temperature setpoint can be increased via diagnostic menu d.46. D.46 provides a means to offset from the default 20°C room set point. For example to increase the target room temperature to 22°C set d.46 to the value 2.

Range of value d.46: -10 to 10.

## (C) Configuring the Outdoor Sensor with external Glow-worm Climapro or Climastat controls

### Choosing and Setting Sensor Heating Curve.

A gradient must be chosen from the range shown on page 17, labelled 0.2-4.

The decision as to which heating curve should be used is based on two factors:

1. The average minimum outside temperature of the region.
2. The maximum temperature which the heating appliance can provide.

**NOTE:** Consider the level of heat loss in comparison to typical UK heat loss e.g. (double glazing, loft insulation and cavity wall insulation).

### Method with example.

The following example describes the process. The temperatures quoted should be substituted with real values to find the required heating curve.

1. Select the average minimum outdoor temperature expected in your region where the sensor will be installed. For example at the peak of winter the temperature may drop to  $-5^{\circ}\text{C}$ . This would be the value selected from the Outdoor temperature  $^{\circ}\text{C}$  axis.
2. Select the maximum output temperature of the heating appliance from the Heating flow temperature ( $^{\circ}\text{C}$ ) axis. For example this could be  $82^{\circ}\text{C}$ .
3. Plot these two points onto the chart. They intersect the heating curve labelled 2.5. The value 6 would be entered into the boiler via the diagnostic menu d.45.

## (C) Configuring the Outdoor Sensor with external Glow-worm Climapro or Climastat controls

---

### **Making Adjustment on Climastat**

Refer to your Climastat instructions, section 6 Commissioning. The heating curve is adjusted via Menu 2. Access to this menu is achieved by following the steps stated in Adjustments.

### **Making Adjustment on Climapro/ Climapro RF**

Refer to your Climapro/Climapro RF Commissioning Instructions. The heating curve is adjusted via menu COMP which is accessible by procedure stated in the table in the Commissioning section.

### **Adjusting Room Ambient**

With the heating curve correctly setup for your specific region, the room temperature can be adjusted. This is achieved by increasing or decreasing the setpoint temperature of your Climastat or Climapro/ Climapro RF roomstat.

For systems with a Glow-worm Climapro. To adjust the room ambient set point temperature, refer to sections, Setting the “Comfort” temperature or Central heating temporary override - central heating of the Climapro instructions for use, installation and servicing literature.

For systems with a Glow-worm Climastat. To adjust the room ambient set point temperature, refer to section 2 instructions for use of the Climapro instructions for use, installation and servicing literature.

## (C) Configuring the Outdoor Sensor with external Glow-worm Climapro or Climastat controls

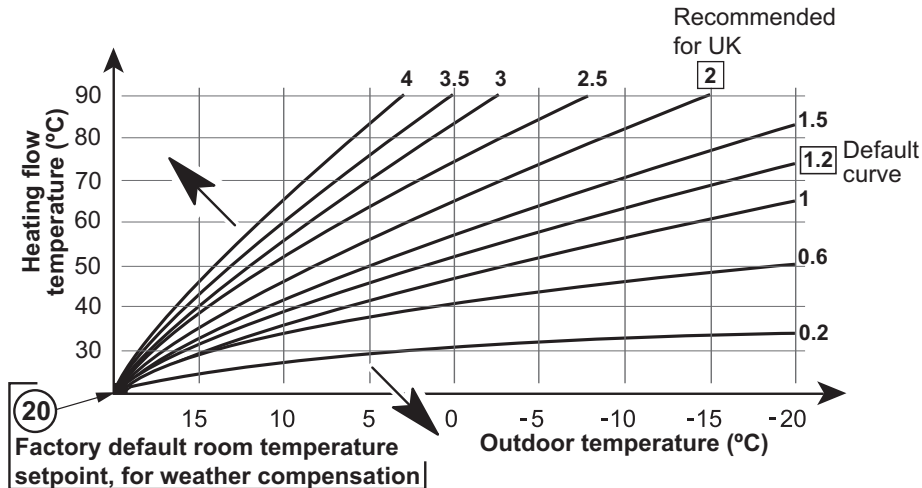

13682

Because of our constant endeavour for improvement, details may vary slightly from those shown in these instructions.

**Glow-worm**, Nottingham Road, Belper, Derbyshire. DE56 1JT