

**Glow-worm**  
The energy you need

## Easicom Technical Product Guide



### Glow-worm

Nottingham Road  
Belper  
Derbyshire  
DE56 1JT

Head Office:  
01773 824 639

Literature:  
01773 596 105

After Sales Service:  
01773 828 100

Technical Advice:  
01773 828 300  
(Boilers)  
08447 361 143  
(Renewables)

Training:  
01773 596 156



INVESTOR IN PEOPLE

[www.glow-worm.co.uk](http://www.glow-worm.co.uk)

**Glow-worm**

EASIGUIDE

# Contents

Contents	02
An Introduction to Easicom	03
Key features and benefits	03
Control compatibility table	04 - 05
Hydracyl cylinders & accessories	06 - 09
Specification Table	10
Product dimensions and clearances	11
Horizontal flueing options & flueing accessories	12
Vertical flueing options & flueing accessories	13
Expert support from start to finish	14 - 15

## Disclaimer

This Technical Guide is intended as a guide only, and should not be used as an alternative to the manufacturers instructions provided at purchase. The information in this guide was correct at the time of going to print. Glow-worm reserve the right to make any modifications to product specifications, or any other details, without prior notification. For further clarification, please enquire in writing to the head office address on the reverse of this brochure.

Visit [www.glow-worm.co.uk](http://www.glow-worm.co.uk) to view and download technical data

# An Introduction to Easicom

The Glow-worm Easicom is the new great value combi boiler from Glow-worm.

Designed and manufactured at Glow-worm's industry-leading facilities in Belper, Derbyshire. The straightforward, value combi boiler range offers performance to rely on and is supported with a FREE 3 year warranty.

Glow-worm's Easicom combi boiler is available in a choice of 24kW and 28kW models, and features an in-built Grundfos pump and a stainless steel heat exchanger for proven reliability and performance.

Complete with a pre-fitted analogue timer and standard horizontal flue, the Easicom boiler is available in a straightforward and easy to order installer pack.

Installation and servicing are made straightforward, with an LCD display using standard Glow-worm diagnostics, and easy access to both 24v and 230v wiring compartments.

Easicom is also LPG compatible with no need for a separate conversion kit.

Easicom provides simple usability for your customers and is quiet in operation.

The new range offers the reliability and quality you'd expect from Glow-worm, backed up by comprehensive service and support with 3 year parts and labour warranty as standard.

## Key Features & Benefits

- New high efficiency combi boiler designed to meet Building Regulations Part L 2010
- Available in 24 & 28kW models offering 9.8 & 11.5l/min
- UK manufactured with Glow-worm's industry-leading facilities
- Stainless steel heat exchanger for proven and reliable performance
- Grundfos pump with daily pump exercise program
- LPG compatible; without the need for a separate conversion kit
- Compatible with Glow-worm Climapro<sub>2</sub> RF
- Easy to use and install
- LCD display to provide straightforward installer and homeowner interface
- Compatible with Glow-worm's full range flue components
- Compatible with Glow-worm's range of intelligent controls
- Sold in great value complete kit; includes boiler, clock and flue\*
- Exclusive 3 year warranty

**Dimensions (mm):**  
740 x 418 x 338mm

**Maximum flue lengths:**  
Ø60/100 mm Horizontal 6m  
Ø80/125 mm Horizontal 10m  
Ø60/100 mm Vertical 6m  
Ø80/125 mm Vertical 10m

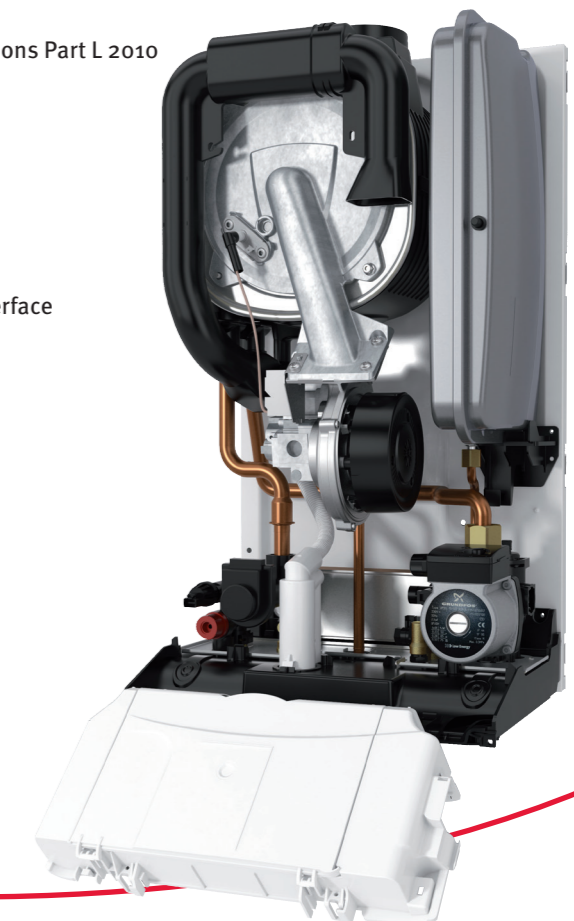

# Control Compatibility Table

The table below summarises the compatibility of the Glow-worm Easicom boiler with our range of intelligent controls. See the table below for more detailed control option information.

Appliance	Climastat	Wired Climapro	Wireless Climapro <sub>2</sub> RF	Wired Outdoor Sensor	Wireless Outdoor Sensor	Glide down analogue timer	Analogue timer	Plug in digital timer	Smart Wiring Centre
Easicom	✓	✓	✓	✓	✓	✗	✓	✗	✗

# Control options

Easicom control options

	Easicom	Climastat	Wired Climapro	Wireless Climapro <sub>2</sub> RF	Wired Outdoor Sensor	Wireless Outdoor Sensor	Plug in analogue or digital timer	Smart Wiring Centre
<b>To achieve room compensation you will need:</b>								
Using inbuilt analogue timer	✓	+	✓	+	✗	✗	✗	✗
or								
Using external controls	✓	+	✗	✓	or ✓	✗	✗	✗
<b>To achieve weather compensation you will need:</b>								
Using inbuilt analogue timer	✓	+	✓	+	✗	✗	✓	+
or								
Using external controls (Wired)	✓	+	✗	✓	+	✗	✓	✗
Using external controls (Wireless)	✓	+	✗	✗	✓	+	✓	✗

# Glow-worm Controls



## Climapro<sub>2</sub> RF

Our innovative wireless programmable room thermostat for advanced heating and hot water control any time of the week.

- Two channel wireless programmable room thermostat with time and temperature control of central heating and hot water
- Backlit display provides advanced user control and functionality
- Simple and initiative to use handheld unit can be wall mounted or portable within the living area
- Capable of room and weather compensation (with outdoor sensor)

## Climastat

Thermostat (Temperature only)

- Easy to use
- Extra low voltage
- Simple & discreet 2 wire connection
- Wiring polarity not important

## Climapro

Programmable room thermostat (Time and temperature)

- Simple 2 channel controller for central heating and hot water
- Provides 24 hour or 7 day timed programme options
- Extra low voltage
- Simple & discreet 2 wire connection
- Wiring polarity not important

## Outdoor Sensor

Weather compensation sensor (Wired)

- Enables weather compensation
- Wired sensor
- Simple and discreet

## Wireless Outdoor Sensor

Wireless weather compensation sensor using inbuilt PV cells

- Enables weather compensation when paired with Climapro<sub>2</sub> RF
- Works on indirect sunlight which re-charges the small PV cells
- Simple and quick to install
- Only works with Climapro<sub>2</sub> RF



# Hydracyl cylinders & accessories

## Single coil cylinders – for traditional heating systems

An integral part of any regular heat only or sealed system;  
Glow-worm cylinders are extremely reliable, hard wearing and come complete with a 25 year warranty against perforation of the steel shell.

They are available in four sizes - 150, 205, 250 and 300 litres and manufactured from high grade stainless steel with laser welded seams.

Our cylinders are built with efficiency and performance in mind, and incorporate excellent insulation that achieves heat loss as low as 1.7kWh/24hrs and a high recovery heating coil that reheats the cylinder in as little as 20 minutes.

### Key Features

- Hydracyl available in 150, 205, 250 & 300 litre models
- High grade stainless steel cylinder with laser welded seams
- Maximum performance with minimum fuel costs.
- Insulation exceeds CHeSS Best Practice
- External expansion vessel supplied
- Complies with WRAS and G3 regulations
- Simple controls and wiring box
- Intelligent system solutions when used with Glow-worm appliances and eBUS controls
- Glow-worm 2 year Guarantee
- 25 Year Warranty on cylinder shell. (Subject to water quality, correct installation and annual servicing).

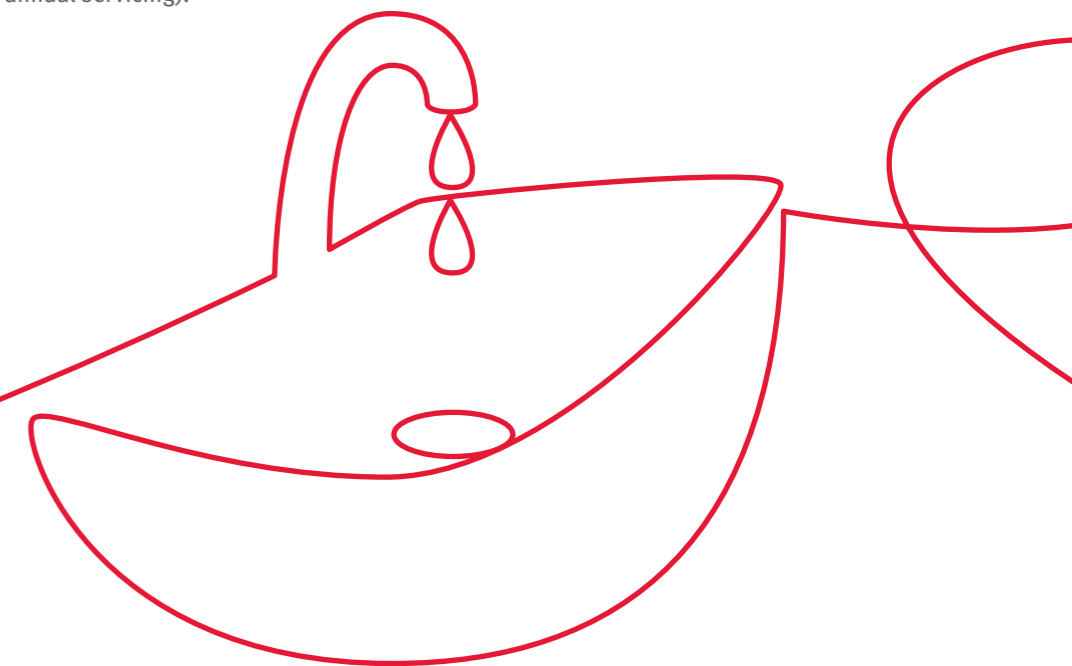
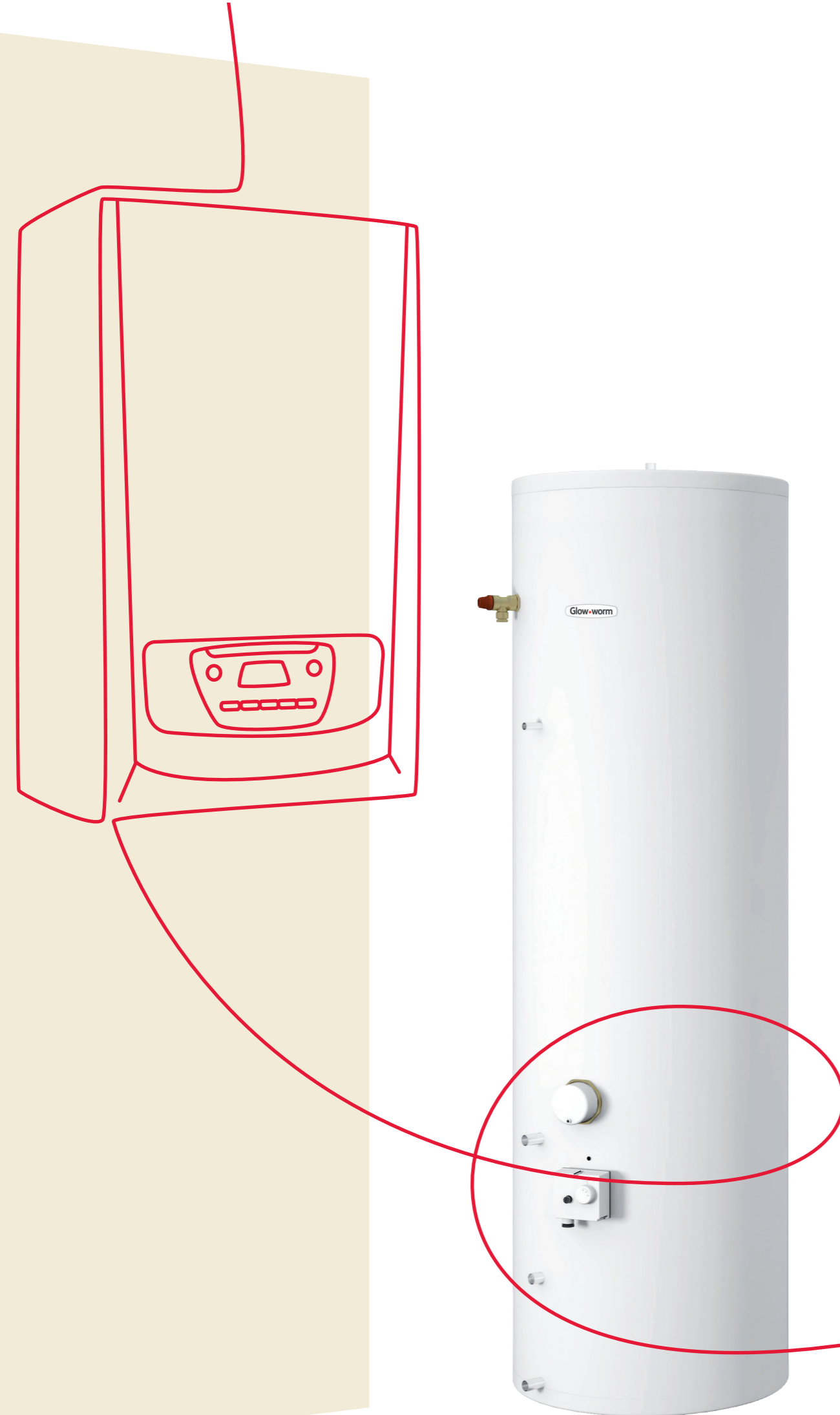

## Accessories: Plume & condensate solutions

Fully compatible with all Glow-worm boilers, these handy accessories help solve plumbing and condensate issues that can be faced when installing modern condensing boilers.

### Plume Management Kit

This clever accessory exhausts plume further away from the duct or building openings, reducing the impact of the vapour trail.

The simple piping kit fits neatly onto the horizontal flue and can be extended to a maximum of 6m in length, fitting easily around ledges and other obstacles to achieve the minimum clearance levels required on installations.



### Plume Deflector Kit

A useful accessory takes the hassle out of flue gas termination by diverting plume left, right or upwards away from problem zones such as adjacent properties or walk ways.

Available in black or white, the Plume Deflector Kit can be installed quickly and simply onto a horizontal flue instead of the standard terminal end piece during or after installation.



### Condensate Pump

To solve problems associated in locating a suitable outlet to drain condensate from the condensing boiler, the Glow-worm Condensate Pump collects the condensate from the boiler and pumps it to a suitable outlet such as a waste system.

The smallest available in the UK, the Glow-worm Condensate Pump operates at maximum efficiency with the reservoir pump discharging all the condensate when the fill level is reached, rather than a stop/start operation.



### Ridge Tile Terminal

The Ridge Tile Terminal accessory is designed to make the roof finish look neater and less obtrusive. Available in a black enamel finish, the ridge tile accessory can be fitted to purpose designed flue outlet ridge tiles and provides a quick and easy design solution.



# Specifications

## Easicom specifications - Combi

Easicom	24	28
<b>Size</b>		
Casing dimensions (h w d)(mm)	740/418/338	740/418/338
Weight (lift)	37kg	38kg
<b>Performance</b>		
CH output (kW) Min/Max	7.7/18	8.8/23.3
DHW output (kW) Min/Max	8/24	9.3/28
DHW flow rate storage/combi (l/min. 35°C rise)	9.8	11.5
SEDBUK rating 2009	89.0	88.5
Nox class 5 (natural gas)	Yes	Yes
LPG Compatible	Yes	Yes
<b>Construction</b>		
Main heat exchanger type	Coiled tube	Coiled tube
Heat exchanger material	Stainless steel	Stainless steel
Burner type	Pre-mixed	Pre-mixed
Fully modulating	Yes	Yes
DHW plate heat exchanger	Yes	Yes
Integrated hydrobloc	Yes	Yes
<b>Installation</b>		
Suitable for sealed systems	Yes	Yes
Suitable for open-vent systems	No	No
Filling loop	No	No
Inbuilt automatic bypass	Yes	Yes
Inbuilt adjustable system bypass	No	No
Inbuilt condensate trap/siphon	Trap	Trap
Inbuilt boiler frost protection	2 stage	2 stage
Zero compartment ventilation	Yes	Yes
<b>Clearances</b>		
Top (mm) (from top of boiler)	150	150
Side (mm)	0	0
Bottom (mm)	200	200
Front (mm) <sup>2</sup>	600	600
<b>User Interface</b>		
User display	2 digit LCD	2 digit LCD
Diagnostics	Advanced	Advanced
User adjustable CH temp control	Yes	Yes
User adjustable DHW temp control	Yes	Yes
Eco setting on DHW	No	No
Pre-fitted analogue timer	Yes	Yes
<b>Pipes</b>		
Pre-fixing jig	No	No
Optional spacing frame	No	No
Water connections	2x22/2x15mm	2x22/2x15mm
<b>Flues</b>		
Max horizontal Ø60/100	6m	6m
Max vertical Ø60/100	6m	6m
Max horizontal Ø80/125	10m	10m
Max vertical Ø80/125	10m	10m
Optional plume management kit Ø60/100	Yes	Yes

# Product dimensions

Range	A	B	C	D	E	F
	Height	Width	Depth	Flue Outlet position 1	Flue outlet position 2	Ø80/125 Flue diameter
<b>Easicom</b>						
Easicom 24 (mm)	740	418	338	130	0 <sup>1</sup>	125
Easicom 28 (mm)	740	418	338	130	0 <sup>1</sup>	125

## Easicom

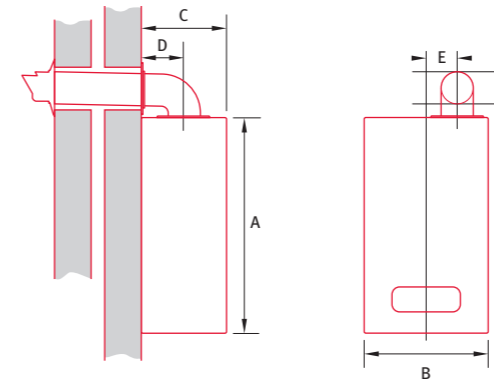

### Notes:

- 1 Flue is central to the boiler.
- 2 A removable compartment door can be placed at least 5mm in front of the appliance.

# Product clearances

Range	A	B	C	D	E	F	G
	Top flue	Top	Side	Bottom	Flue#1	Flue#2	Front
<b>Easicom</b>							
Easicom 24 (mm)	150	5	0	200	5	5	600 <sup>2</sup>
Easicom 28 (mm)	150	5	0	200	5	5	600 <sup>2</sup>

## Easicom

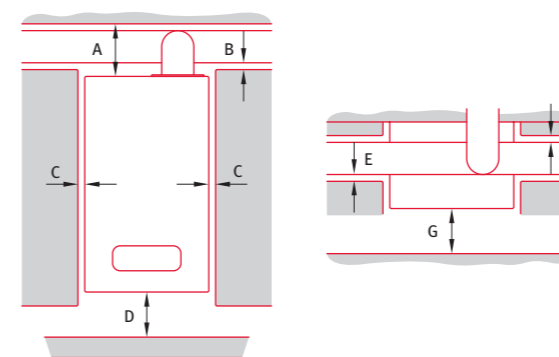

# Horizontal flueing options

## Horizontal flue lengths

The horizontal flueing information below applies to all Glow-worm High Efficiency boilers.

Boiler	Ø60/100 Max horizontal	Ø80/125 Max horizontal	Compatible with Plume Management Kit
Easicom 24	6m	10m	Yes <sup>1</sup>
Easicom 28	6m	10m	Yes <sup>1</sup>

### Top rear and top side horizontal flue options

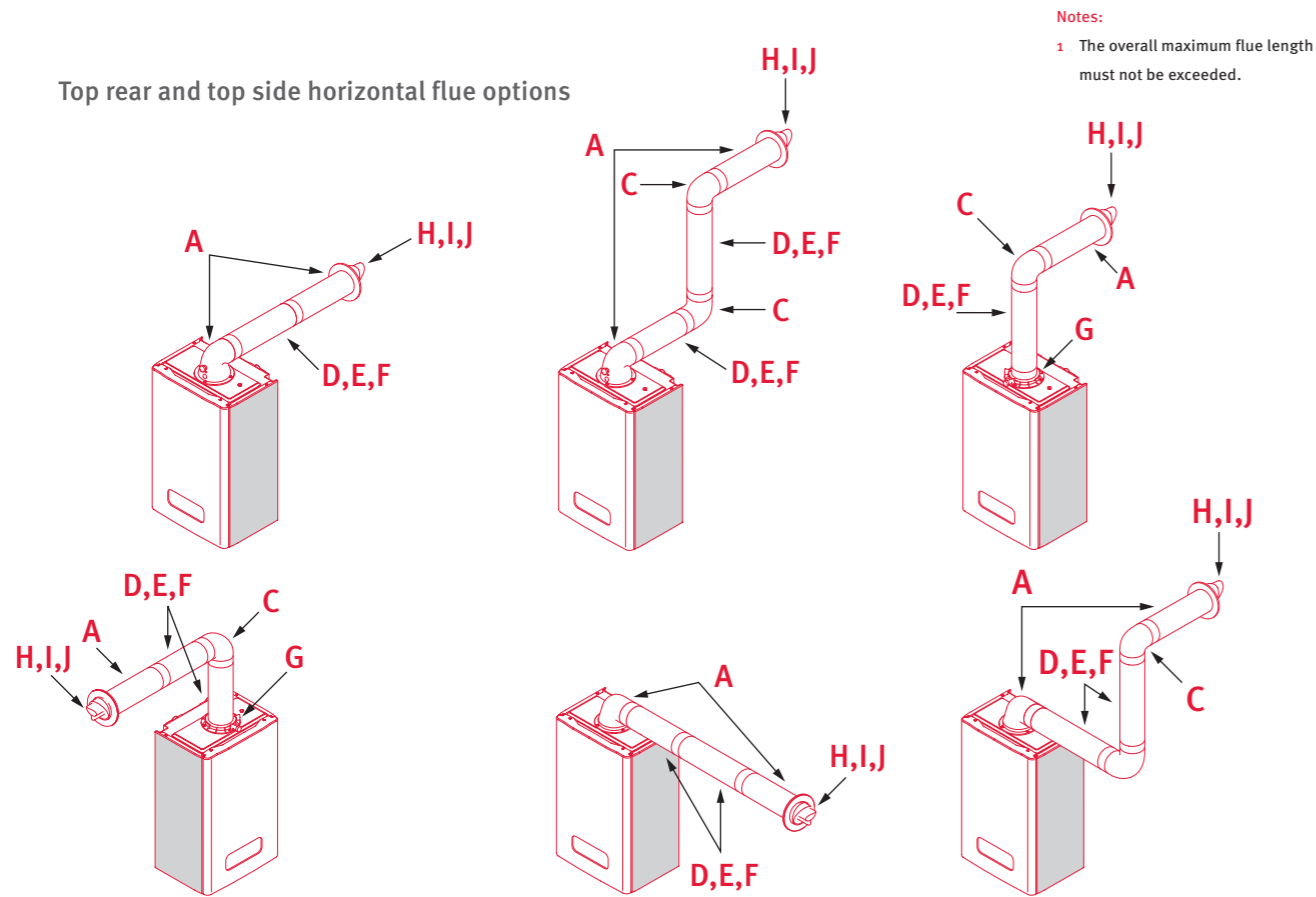

### Horizontal flue accessories

Component	Description	Part Number Ø60/100	Part Number Ø80/125
A	Horizontal Telescopic flue	A2043600	0020104551
B	45° Bend (2 off)	2000460485	0020104557
C	90° Bend (1 off)	2000460484	0020104556
D	0.5m Extension (1 off)	2000460481	0020104553
E	1m Extension (1 off)	2000460482	0020104554
F	2m Extension (1 off)	2000460483	0020104555
G	Vertical Flue Adaptor	A2024600	0020104550
H	Deflector Terminal (Black)	0020060582	-
I	Deflector Terminal (White)	0020060583	-
J	Black Terminal	A2043700	-

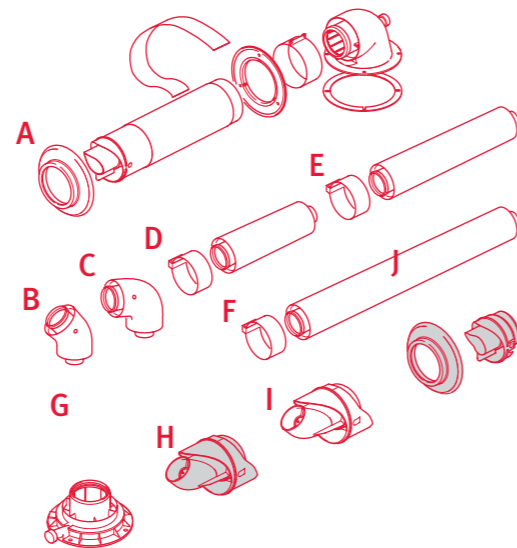

# Vertical flueing options

## Vertical flue lengths

The vertical flueing information below applies to all Glow-worm High Efficiency boilers.

Boiler	Ø60/100 Max vertical	Ø80/125 Max vertical	Compatible with Plume Management Kit
Easicom 24	6m	10m	Yes <sup>1</sup>
Easicom 28	6m	10m	Yes <sup>1</sup>

### Vertical flue options

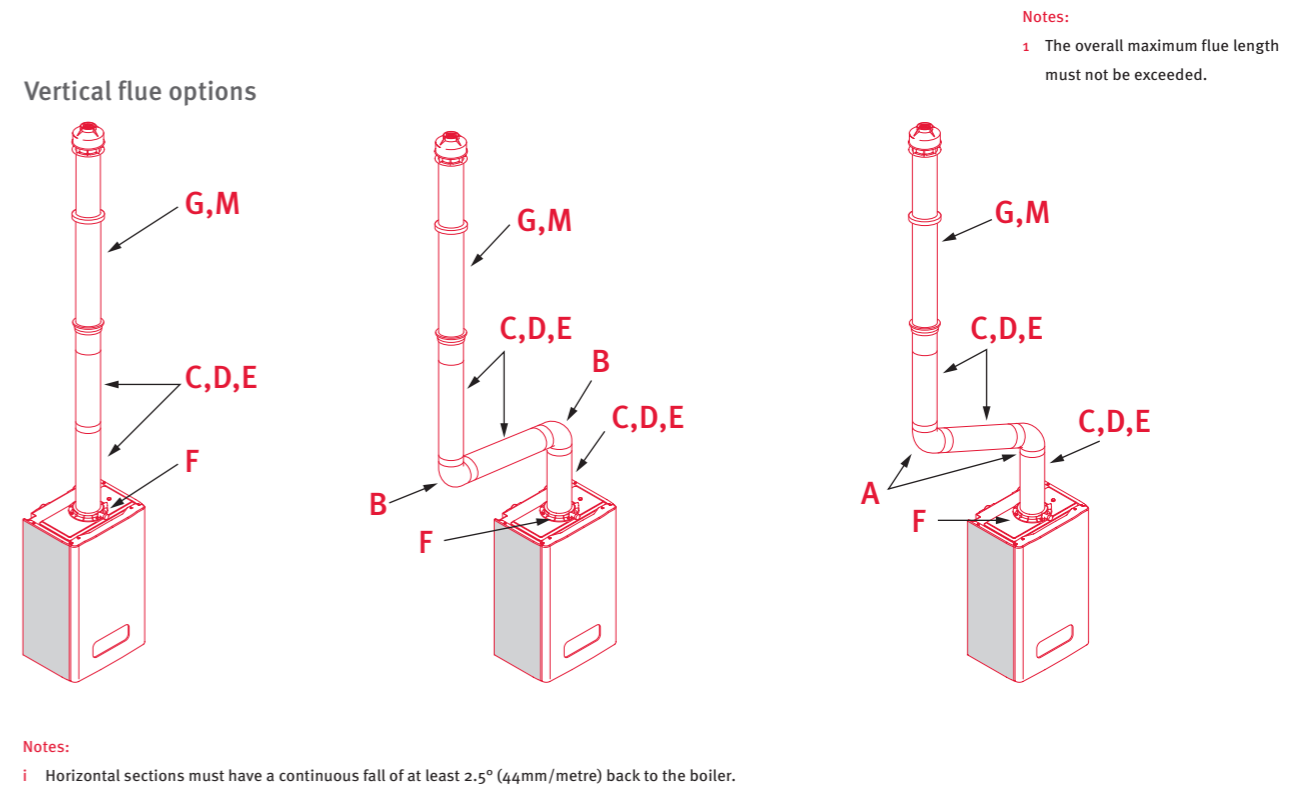

### Vertical flue accessories

Component	Description	Part Number Ø60/100	Part Number Ø80/125
A	45° Bend (2 off)	2000460485	0020104557
B	90° Bend (1 off)	2000460484	0020104556
C	0.5m Extension (1 off)	2000460481	0020104553
D	1m Extension (1 off)	2000460482	0020104554
E	2m Extension (1 off)	2000460483	0020104555
F	Vertical Flue Adaptor	A2024600	0020104550
G	Vertical Roof Terminal	2000460480	0020104552
H	Pitched Roof Flashing	2000460479	-
I	Flat Roof Flashing	2000460478	-
J	Sliding Sleeve	2000460487	0020104558
K	Fixing Bracket (5 off)	2000460486	0020104559
L	Telescopic Extension	A2036900	-
M	Ridge Tile Terminal	A2043800	-

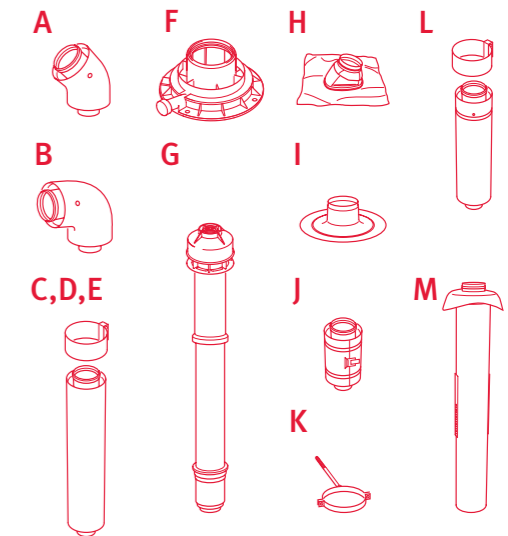

## Expert support from start to finish

As well as providing durable, reliable products, Glow-worm supports you from the beginning of your installation for years into the future. From design, technical help, extensive training courses and specialist onsite support to a nationwide after sales and spares network, Glow-worm provide you with expert help and support whenever you need it.



## Top-class service

### Technical help

If you are planning or even in the middle of an installation and have a technical question you need answering, simply call our technical help line for a straightforward answer.

### System design

Glow-worm's award winning Design Service is a complete service tailored to suit your individual site requirements. From basic heating designs to more complex solutions using the latest renewables technologies, Glow-worm design uses state of the art CAD technology to provide high quality designs supported by full indemnity cover.

### Full local support

Our nationwide sales team provide installers and specifiers with support and partnership from beginning to end.

### Nationwide after sales service

We are committed to supporting you with technical help and after sales service online, over the telephone and on the road.

All our service engineers are Gas Safe registered and are fully trained on all Glow-worm's models past and present. We have around 250 engineers based across the UK, each carrying over 1,500 different spare parts in their van enabling them to achieve an outstanding 97% first time fix rate.

### Product warranty

All Glow-worm products are designed to exacting industry standards, and are individually tested to ensure reliability. All Ultracom, Flexicom and Ultrapower boilers come with 2 years parts and labour warranty as standard with extended warranty options available.

### Spares

If in the unlikely event a problem occurs and a spare part is needed, then you can rest assured that Glow-worm's market leading spare parts division will have the item you require. Thanks to our commitment towards maintaining functional spare parts, availability is for up to 15 years after the range production ends.

Glow-worm has a nationwide network of over 30 key spares stockists at approximately 450 locations around the UK which means getting hold of a genuine Glow-worm spare part is as convenient as possible. If for any reason the items are not held by the stockist, Glow-worm offers a next day delivery service for emergency orders.

### Online information

If you want standard technical advice information such as installation manuals and flueing information and don't want to spend time on the telephone, visit our website at [www.glow-worm.co.uk](http://www.glow-worm.co.uk) where you will find comprehensive technical information, solutions to common installation, system problems and advice on saving energy.

### Always within reach, always there for you

**Head Office:**  
01773 824639

**Literature:**  
01773 596105

**After Sales Service**  
01773 828100

**Technical Advice:**  
01773 828300  
(Boilers)  
08447 361 143  
(Renewables)

**Glow-worm design:**  
0116 2392393

**Spare Parts:**  
01773 596188

service