

Technical Datasheet - Stair Nosing

Heavy Duty Ceramic Tile-In Nosing - NTC

Product Description

This Heavy Duty Aluminium Tile-In Nosing offers a cost effective alternative to ceramic treads. The PVC insert on the tread has been designed to provide additional slip resistance. Although mainly used with ceramic tile it can also be used with wood, laminate and stone. It also meets with DDA Guidelines and Building regulations.

Also available with Aluminator option.

Dimensions and Colour

Available in 3.22m Lengths, and available in a large selection of colours, please refer to our website for more details www.genesis-aps.com

Range

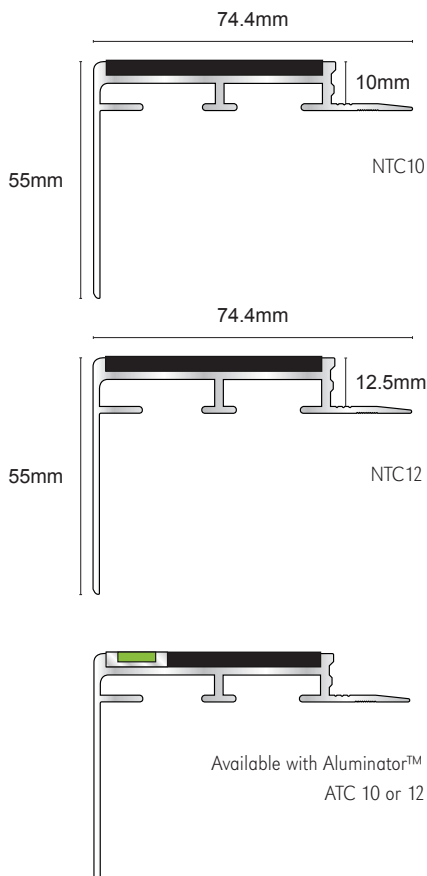

Technical Details

Chemical composition:

In accordance with BS EN 573-3:2003

Aluminium and aluminium alloys. The trace elements of the composition which determine the alloy selected are 6063

Thermal Treatment designations:

T6. To the best of our knowledge this is at least equal to the best in the market.

Manufacturing Tolerance:

In accordance with BS EN 755.

Maintenance

Inserts: All inserts should be cleaned using a neutral detergent and thoroughly rinsed with clean water. Ensure all inserts are dry prior to receiving foot traffic.

Aluminium Channel: These can be polished using steel wool or cloth to maintain the appearance - under no circumstances should solvent cleaners be utilised in cleaning or maintaining Genesis Aluminium Products.

Installation

1. Measure and cut the profile to desired length.
2. If required fix tile to riser.
3. Bed the profile into the adhesive ensuring the adhesive penetrates through the anchoring holes. Adjust accordingly and position the profile so the front edge covers the tile on the riser if fitted.

Aluminium AA 6063 T6 / UNS A96063 anodised to DIN 17611

Si%	0.2-0.6
Fe%	0.35
Cu%	0.1
Mn%	0.1
Mg%	0.45-0.9
Zn%	0.1
Ti%	0.1
Cr%	0.1
Al	Balance

P.V.C. Trim • Stair Nosings • Expansion Joints • Transitions • Seals • Edge Protection • Metal Trim • Skirting • Tools

Tel: +44 (0)1642 713000

Email: info@genesis-gs.com

www.genesis-gs.com

UK Head Office & Factory
Stokesley Business Park Stokesley
North Yorkshire TS9 5JZ UK



Genesis
For the Perfect Finish

