

Environmental Product Declaration

according to EN 15804



1 General information

1.1 Declaration holder

Geberit International AG
 Schachenstrasse 77
 CH-8645 Jona
 Tel. +41 55 221 63 00
 sustainability@geberit.com
 www.geberit.com

Geberit is one of the pioneers when it comes to sustainability in the sanitary industry. Sustainable development has formed part of the corporate strategy for more than 20 years. Most production sites are certified in accordance with ISO 9001 and 14001. In addition, all factories will be certified in accordance with OSHAS 18001 by 2018. Life cycle assessments were produced for key products from an early stage and Ecodesign has been an integral part of the product development process since 2008. As a member of the United Nations Global Compact, Geberit has shown its commitment to the ten principles of sustainable development. Current and comprehensive information regarding sustainability strategy and performance with respect to Geberit and Geberit products can be found in the current Annual Report. Furthermore, additional information can be found under www.geberit.com/company/sustainability.

1.2 Declared product

This declaration applies to Geberit urinals Preda and Selva.

1.3 Verification and validity

Programme holder: Geberit International AG
 Declaration number: GEB_EPD_D78803
 Validity: 01/01/2016 to 01/01/2021
 Data calculated by: Quantis
 www.quantis-intl.com

EPDs for building products are not always comparable if they do not conform to EN 15804.

The European standard EN 15804 is used as the core PCR.	
Independent verification of the Declaration in accordance with EN ISO 14025:2010	
<input type="checkbox"/> Internal	<input checked="" type="checkbox"/> External
 _____ Dr Frank Werner	

2 Product

2.1 Description and application

Two rimless urinal ceramic appliances developed by Geberit are key parts of the new Geberit urinal system: Geberit urinal Preda and Geberit urinal Selva.

The Geberit urinals Preda and Selva can be combined with either an electronic (mains, battery or generator operation) or pneumatic control, and are also capable of waterless operation.

The urinal system consists of perfectly matched components which can be combined in a variety of different ways and enable the greatest possible flexibility in planning.

The product boasts the following key benefits:

- easy installation
- simplified service and cleaning
- major savings opportunities in terms of water consumption thanks to the different operation modes and the associated low operation and maintenance costs

The Geberit urinal Preda, with integrated control, mains operation (116.072.00.1) has been used as a reference article. The sales articles listed below differ only insignificantly from the reference article and are therefore part of the range of validity of this environmental product declaration.

Type	Article number	Article designation
Preda	116.070.00.1	Geberit urinal Preda, for concealed urinal control
	116.071.00.1	Geberit urinal Preda, waterless
	116.072.00.1	Geberit urinal Preda, with integrated control, mains operation
	116.073.00.1	Geberit urinal Preda, with integrated control, battery operation
	116.074.00.1	Geberit urinal Preda, with integrated control, self-sustaining power supply
	116.075.00.1	Geberit urinal Preda, for integrated control
Selva	116.080.00.1	Geberit urinal Selva, for concealed urinal control
	116.081.00.1	Geberit urinal Selva, waterless
	116.082.00.1	Geberit urinal Selva, with integrated control, mains operation
	116.083.00.1	Geberit urinal Selva, with integrated control, battery operation
	116.084.00.1	Geberit urinal Selva, with integrated control, self-sustaining power supply
	116.085.00.1	Geberit urinal Selva, for integrated control

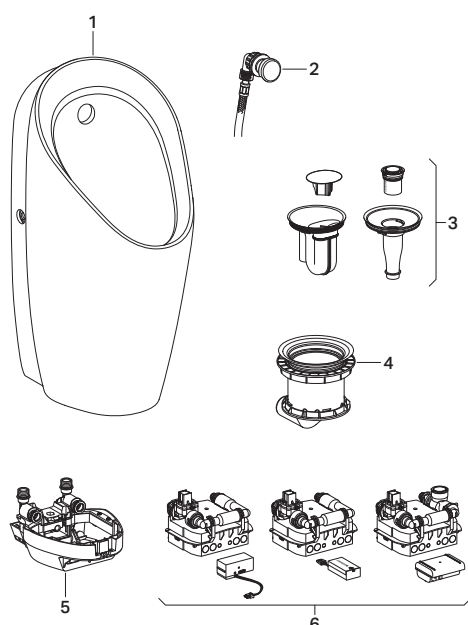

- 1 Urinal ceramic appliance
- 2 Spray head with reinforced braided hose
- 3 Trap (suction or hybrid trap)
- 4 Trap housing
- 5 Docking station
- 6 Control unit (mains, battery, generator)

2.2 Characteristics

- Three different operating modes:
 - urinal flush control integrated into the ceramic sanitary appliance
 - separate concealed urinal control
 - for completely waterless operation
- Two rimless ceramic designs:
 - Geberit urinal Preda
 - Geberit urinal Selva
- Integrated urinal flush control which can be operated using three power supply variants:
 - mains supply
 - battery supply
 - self-sustaining via generator
- Flushing out the urinal ceramic appliance with 0.5 l per flush ensures compliance with EN 13407
- Additional opportunities for saving water thanks to different operation modes:
 - dynamic flushing time adjustment (hybrid)
 - waterless operation
- Minimum cleaning effort thanks to a particularly hygienic, rimless ceramic sanitary appliance
- Easy to service thanks to easily accessible components without first having to remove the urinal ceramic appliance

2.3 Technical data

Power consumption	< 0.5 W
Power consumption standby	0.1 W

2.4 Consumption data

Annual water consumption is between 4380 and 36,500 litres, depending on the operation mode and intensity of use. The corresponding energy consumption is less than 1 kWh per year.

Consumption scenario	Intensity of use		Water consumption Litres per year	Energy consumption kWh per year
	per day	per year		
High use (airport/train station), 0.5 l per use	200	73,000	36,500	0.66
High-use (airport/train station) hybrid operation, 2 l per hour, 18 hours a day	200	73,000	13,140	0.66
Medium use (office/restaurant), 0.5 l per use	50	18,250	9,125	0.44
Medium-use (office/restaurant) hybrid operation, 2 l every 2 hours, 12 hours a day	50	18,250	4,380	0.44

2.5 Conformity and label

The product complies with the following standards, among others:

EU statutory requirements		
2014/35/EU	2006	Low Voltage Directive
2014/30/EU	2004	EMC Directive
2011/65/EU	2011	RoHS 2 Directive
2012/19/EU	2002	WEEE 2 Directive
2009/125/EC	2009	Ecodesign Directive
EC no. 1907/2006	2006	REACH Regulation
EC no. 1275/2008	2008	Standby Losses Regulation
2006/66/EC	2006	Batteries Directive
2008/103/EC	2008	Directive 2008/103/EC of the European Parliament and the Council of 19 November 2008 regarding the revision of Directive 2006/66/EC regarding batteries and accumulators as well as used batteries and used accumulators with respect to the launching of batteries and accumulators

Relevant declarations of conformity can be downloaded from the websites of our local sales companies.

Voluntary labels:

- WELL (label not yet available)

2.6 Raw material

The product consists of the following raw materials:

Raw material	Unit	Mains operation	Battery operation	Generator operation	Waterless
Aluminium	g	18	17	17	17
Brass	g	71	71	71	71
Ceramic	g	16,400	16,400	16,400	16,400
Copper	g	28	9	12	–
Plastic	g	1,900	1,859	1,940	1,142
Electronics	g	112	79	87	–
Steel	g	540	539	542	412
Battery	g	–	–	78	–
Total	kg	19.1	19.0	19.2	18.0
Recycling portion of raw materials	%	1.8	1.7	1.7	1.4

The product is delivered in a cardboard box (5.3 kg) with the operating and installation manuals (283 g of paper). The total weight of the mains version is therefore 24.7 kg. The only difference between the Geberit urinals Preda and Selva is that the urinal ceramic appliance of the Geberit urinal Selva is slightly larger and therefore heavier (17.8 kg). The total weight of the Geberit urinal Selva is therefore 26.1 kg.

2.7 Manufacturing

The mounting takes place at the Geberit site in Rapperswil-Jona (CH). Some plastic and metal components are manufactured in Rapperswil-Jona and in the Geberit production sites in Shanghai (CN), Lichtenstein (DE) and Pottenbrunn (AT). The other components are purchased parts. All suppliers sign the Geberit suppliers' code of conduct and undergo a detailed selection and inspection procedure.

2.8 Distribution

Transportation from Geberit to the customer within Europe is made via the state-of-the-art and efficient central warehouse in Pfullendorf (DE) using lorries and outside of Europe mainly by means of freighters together with lorries to distribute the products locally. This is handled by logistics partners who have fleets of modern lorries.

2.9 Installation

Installation is simple and does not require any additional energy consumption or use of materials. The packaging waste produced (cardboard, paper) can be fully recycled while the PE foil is converted into energy.

2.10 Use

Although use is not part of this environmental product declaration, some useful information is provided on this subject.

Urinal flush control

The water-flushing Geberit urinals Preda and Selva (mains, battery and generator operation) can be operated in three flush modes.

- User-dependent flush: the urinal is flushed automatically after each use
- Time-dependent (hybrid) flush: the urinal is flushed at predefined intervals
- Waterless: the urinal is operated waterlessly, i.e. without flushing

The amount of water used in the flush can be defined precisely and can be adjusted to the needs of customers or users. The Geberit urinals can also be flushed with grey water or rainwater. The waterless Geberit urinal system can only be operated waterlessly. Relevant consumption data is available in chapter 2.4.

Cleaning

The cleaning method for Geberit urinals depends on the flush mode. The rimless urinal ceramic appliance and the easily accessible spray head reduce cleaning effort. Furthermore, the wall-mounted fastening permits barrier-free and easy cleaning of the floor.

Waterless urinals generally require more cleaning effort.

Service / maintenance

Service and maintenance of the Geberit urinals depend on the intensity of use and the flush mode. All function elements such as the spray head, trap and control unit are easily accessible. The ceramic sanitary appliance therefore does not have to be removed for maintenance work, which ensures availability. Waterless urinals generally require more service effort than flushed urinals. During a period of utilisation of 20 years, the trap, trap housing, outlet pipe and spray head must be replaced.

2.11 End-of-life

Electronic and metal parts are fully recyclable when disposed of appropriately. It is assumed that plastic parts are converted into energy and ceramic is disposed of in a landfill for inert matter. However, the electronics found in the Geberit urinal must be disposed of separately.

The device can be uninstalled easily without requiring modifications to the domestic installation.

3 Life cycle assessment – Calculation criteria

3.1 System boundaries

This environmental product declaration is a "cradle to factory gate with options" declaration and includes the construction process and end-of-life. The use stage and the demolition stage are not included, as the former depends on the user and the latter is not relevant. The study covers the European market situation.

Product			Construction process		Use	End-of-Life			
Raw material	Transport to the manufacturer	Manufacturing	Distribution	Installation within the building		Demolition	Transport to waste processing	Reuse, recovery, recycling	Disposal
A1	A2	A3	A4	A5	B1–B7	C1	C2	C3	C4
x	x	x	x	x	–	–	x	x	x

– not considered / not relevant

3.2 Technical scenario information and assumptions

(A1) For the raw material supply, the entire raw and recycled material input was modelled using corresponding European data, including the losses of 1 to 6% relating to material and production. Secondary raw materials comprise those environmental influences that arise from the collection of waste and from recycling. The following recycled content was recorded: 25% for aluminium, 55% for copper and steel, 33% for brass and 100% for cardboard.

(A2) For transportation from the suppliers in Europe and Asia (urinal ceramic) to Geberit, standard transport distances were assumed for each country and a capacity contained in the background data was used. Class Euro 4 diesel lorries are used as the means of transport within Europe. Intercontinental transportation consists of freighters and subsequent local distribution by lorry.

(A3) The use of electricity and heat plays a key role in the manufacturing of the urinal ceramic in China. The Chinese electricity and global heat supply mix was therefore used accordingly. The manufacturing of plastic and metal parts in Switzerland and Germany was approximated with European data records. The electricity consumption during mounting was mapped out with the Swiss electricity mix. The consumption of additional substances and water is negligible. Reliable background data was used for purchased components.

(A4) The distribution to the end users is based on the planned sales figures. Transportation is carried out primarily with diesel lorries and is modelled according to the average vehicle load from Ecoinvent and the current Geberit fleet mix consisting predominantly of Euro 5 vehicles (8.4% Euro 6, 82.6% Euro 5, 4.4% Euro 4 and 4.6% Euro 3). Around two thirds of the products are distributed to EU countries (on average over 425 km). The rest are exported overseas. A transport distance of 900 km is assumed here for lorry transportation to the Port of Rotterdam and 19,481 km for the container ship.

(A5) Apart from packaging waste (paper, cardboard and PE foil), no additional material flows are generated during installation. 100% of cardboard and paper is recycled. The PE foil is transported via 40 t lorry to the refuse incineration plant 10 km away and incinerated. The assumed energy content is 16 MJ, while the assumed energy efficiency is 42% for heat and 14% for electricity.

(C1–C4) Waste that is reused is removed from the product system without causing any environmental impact from the first life cycle. No credits are accounted for cases where production of such waste was avoided. With respect to disposal, it has been assumed that all waste is collected once it has been taken from the building site and is sorted appropriately. 100% of all metal and electronics parts are recycled accordingly. The plastic parts are incinerated (given the assumptions described above), while ceramic is disposed of in a landfill for inert matter. A transport distance of 10 km is assumed for both disposal options.

3.3 Data basis

This environmental product declaration is based on a comprehensive life cycle assessment according to ISO 14044:2006. A detailed background report, which meets the requirements of EN 15804, is used for verification.

The stock data are based predominantly on average annual production data, which were provided by Geberit AG for 2014. Ecoinvent data (version 3.1, year 2014; www.ecoinvent.org) and the system model "cut-off by classification" were used for all further data. The quality of the data can therefore be considered to be good. Modelling and all calculations were carried out with the aid of an Excel table.

The results in chapter 4 refer to the reference article 116.072.00.1 (Geberit urinal Preda with integrated control, mains operation). The Geberit urinal Selva requires approx. 10% more ceramic, but is otherwise identical in structure. The need for more ceramic does not lead to any significant changes to the results compared with the reference article. This means that the results increase for the Geberit urinal Selva by a maximum of 1–4%.

4 Life cycle assessment – results

4.1 Environmental impacts

	Unit	A1	A2	A3	A4	A5	C2	C3	C4
Global warming (GWP)	kg CO ₂ -eq	20.4	7.53	49.2	9.91E-01	7.80E-02	1.53E-02	4.48	8.92E-02
Ozone depletion (ODP)	kg CFC-11-eq	1.40E-06	1.27E-06	2.50E-06	1.88E-07	7.75E-11	2.91E-09	3.00E-08	5.42E-06
Photochemical ozone creation (POCP)	kg C ₂ H ₄	9.16E-03	4.08E-03	1.38E-02	1.73E-04	2.93E-07	2.68E-06	3.59E-05	3.29E-05
Acidification (AP)	kg SO ₂ -eq	1.63E-01	1.22E-01	2.99E-01	3.57E-03	7.08E-06	6.31E-05	1.01E-03	6.80E-04
Eutrophication potential (EP)	kg PO ₄ ³⁻ -eq	6.73E-02	1.31E-02	4.94E-02	7.43E-04	1.36E-05	1.35E-05	9.78E-04	1.39E-04
Consumption of abiotic resources, fossil energy sources (ADP)	MJ	320.0	114.0	659.0	16.4	6.22E-03	2.55E-01	9.88E-01	2.65
Consumption of abiotic resources, elements (ADP)	kg SB-eq	7.16E-04	6.06E-06	2.94E-05	2.21E-06	1.08E-09	3.42E-08	2.81E-07	1.11E-07

4.2 Resource use

	Unit	A1	A2	A3	A4	A5	C2	C3	C4
Use of primary energy, renewable, total	MJ	27.4	2.09	4.63	2.34E-01	1.91E-04	3.63E-03	7.56E-02	5.94E-02
Use of primary energy, renewable, w/o raw material use	MJ	1.60E-03	0	83.9	0	0	0	0	0
Use of primary energy, renewable, raw material use	MJ	27.4	2.09	88.5	2.34E-01	1.91E-04	3.63E-03	7.56E-02	5.94E-02
Use of primary energy, non-renewable, total	MJ	335.0	118.0	712.0	16.7	6.48E-03	2.59E-01	1.12	2.69
Use of primary energy, non-renewable, w/o raw material use	MJ	17.3	0	4.16E-01	0	0	0	0	0
Use of primary energy, non-renewable, raw material use	MJ	352.0	118.0	713.0	16.7	6.48E-03	2.59E-01	1.12	2.69
Use of secondary materials	kg	1.09E-03	0	5.620	0	0	0	0	0
Use of renewable secondary fuels	MJ	0	0	0	0	0	0	0	0
Use of non-renewable secondary fuels	MJ	0	0	0	0	0	0	0	0
Use of net fresh water	m ³	2.68E-01	7.78E-03	2.34E-01	9.48E-04	1.72E-05	1.47E-05	2.18E-03	1.69E-04

4.3 Output flows and waste

	Unit	A1	A2	A3	A4	A5	C2	C3	C4
Hazardous waste	kg	4.29E-03	5.97E-05	6.24E-04	9.07E-06	2.43E-08	1.40E-07	4.64E-06	1.69E-06
Non-hazardous waste	kg	9.75	3.19	1.48	1.45	6.93E-04	2.25E-02	4.75E-02	1.64E+01
Radioactive waste	kg	2.80E-01	3.98E-02	4.89E-01	5.29E-03	5.36E-04	8.18E-05	3.56E-02	2.98E-04
Components for re-use	kg	0	0	0	0	0	0	0	0
Materials for recycling	kg	0	0	1.47E-01	0	5.59	0	8.93E-01	0
Materials for energy recovery	kg	0	0	0	0	0	0	0	0
Exported energy – electricity	MJ	0	0	3.39E-01	0	5.82E-02	0	4.27	0
Exported energy – heat	MJ	0	0	1.02	0	1.75E-01	0	12.8	0

- A1 Raw material
- A2 Transport to the manufacturer
- A3 Manufacturing
- A4 Distribution
- A5 Installation within the building
- C2 Transport to waste processing
- C3 Reuse, recovery, recycling
- C4 Disposal

5 Green building information

Geberit provides system solutions for sustainable building and is an active member of the following associations:

- German Sustainable Building Council, DGNB (DE)
- Minergie for sustainable building (CH)
- Green Building Council – USGBC (USA)
- Greenbuild, sustainable building (AU)

Certain information in this environmental product declaration can be used for the assessment and verification of the various certification systems for sustainable building.

5.1 DGNB

Relevant criteria in the building label for the German Sustainable Building Council (DGNB), scheme for new office and administration buildings, version 2015.2 on designing and assessing sustainable buildings:

Topic	Criterion		EPD chapter
Ecological quality	Life cycle assessment – emissions-related environmental effects	ENV 1.1	4.1
	Risks for local environment	ENV 1.2	2.5, 2.6
	Life cycle assessment – resource consumption	ENV 2.1	4.2
Economic quality	Potable water demand and waste water production	ENV 2.2	2.4, 2.10
	Life cycle costs	ECO 1.1	2.10
Technical quality	Ease of cleaning	TEC 1.5	2.10
	Ease of demolition / dismantling	TEC 1.6	2.11

The topics and criteria that have not been listed for this product are not directly relevant. For assessment in accordance with ENV 2.1, repairs and maintenance work and the operational water requirements during the period under review were not included and are excluded by the system boundaries (see chapter 3.1).

5.2 MINERGIE-ECO

The quality label MINERGIE-ECO of the Minergie organisation assesses new constructions and modernisation projects according to a requirements specification in the current valid version 1.2.

The product does not contain any constituents which violate the exclusion criteria of a MINERGIE-ECO certification (NA01/MA01-NA14/MA16). The requirement for efficient urinals with regard to sanitary appliances in the "Drinking water efficiency" check list can be filled in with the response "Yes" (NG09/MG09, NG10/MG10). The requirement for compliance with sound insulation class 1 for sanitary appliances as per the "Technical building systems sound insulation" check list can be filled in with the response "Yes" (NS05/MS05).

The additional requirements concerning the product materials and construction processes, building concept, sound insulation and indoor climate areas are either not relevant or the product completely complies with them.

5.3 LEED v3

Relevant topics and criteria of the US Green Building Council for the design, construction, operation and maintenance of sustainable buildings in accordance with the Rating System for New Construction and Major Renovations, 2009:

Topic	Criterion	Punktekategorie	EPD chapter
Water Efficiency (WE)	Water use reduction	WEp1	2.4, 2.10
		WEc3	2.5
Energy and Atmosphere (EA)	Optimized energy performance	EAc1	2.3, 2.4
Materials and Resources (MR)	Recycled content	MRc4	2.6
	Local/regional materials	MRc5	2.7

The Geberit urinal system with adjustable operation modes (hybrid, waterless) is rated below the specification of the LEED requirement for water efficiency in public urinals (1.0 gallon per flush [gpf] or 3.8 litres per flush – as per WEp1). Through the use of rainwater or the hybrid mode, additional savings in potable water can be achieved (WEc3). The achievement of the number of points (credits) being strived for is always dependent on all other installed sanitary appliances.

The topics and criteria that have not been listed for this product are not directly relevant.

5.4 LEED v4

Relevant topics and criteria of the US Green Building Council for the design, construction, operation and maintenance of sustainable buildings in accordance with the Rating System for New Construction and Major Renovations, 2013:

Topic	Criterion	EPD chapter
Water Efficiency (WE)	Water use reduction	2.4, 2.10
		2.5
Energy and Atmosphere (EA)	Optimized energy performance	2.3, 2.4
Materials and Resources (MR)	Environmental product declaration	1.3
	Material ingredients	2.6, 4

Analogous to LEED v3, the requirements described there are also fulfilled in LEED v4.

The topics and criteria that have not been listed for this product are not directly relevant.

Geberit International AG
Schachenstrasse 77
CH-8645 Jona

T +41 55 221 63 00
F +41 55 221 63 16
documentation@geberit.com

→ www.geberit.com