

Uniclass

L731

CI/SfB

(52.5)

lh

GATIC Slotrain®

Specialised Engineering. Special Advice.

Technical brochure

- Applications
- Features and benefits
- Technical details
- Handling, installation and maintenance
- System design

'The best drainage system is the one you can't see'.

Gatic is a British company renowned for the manufacture and supply of innovative, engineered access covers and surface water drainage systems to the construction, transport and utility markets. The company has established its worldwide reputation by consistently providing high quality, high performance products over more than eighty years.

Today, with offices, production facilities and distributors located throughout the world, Gatic is recognised as a leading global brand for access cover and surface water drainage systems.

Gatic Slotdrain

Gatic's core business has traditionally been driven by its success in meeting the heavy demands of the world's major air and sea ports. In fact, Slotdrain's unusual channel profile was originally developed in conjunction with leading construction industry professionals from the airport sector.

The concept has, however, proved infinitely scalable and has now been developed into a comprehensive range of products allowing its benefits to be spread to smaller projects such as landscaping schemes, shopping developments and parking facilities.

Future challenges

We hope you will find what you need in these pages but, despite the wide variety of accessories and systems available, there is always a new challenge to rise to. At Gatic, we never expect to rest on our laurels and intend to continue to supply products that meet and exceed our customers' expectations well into the foreseeable future.

Introduction	2
Contents	3
Slotdrain, Product Overview	4
Slotdrain, Product Illustration	6
Quality Assurance	8
Safety and the Environment	9
Slotdrain, Product Applications	10
Product Selector	12
Slotdrain Channels, Overview	13
Access, Outlet and Silt Boxes, Overview	16
Accessories, Overview	17
FacadeSlot	18
PaveSlot	20
UniSlot	22
CastSlot 8 D400	24
CastSlot 28 D400	26
CastSlot 8 F900	28
CastSlot 28 F900	30
UltraSlot	32
UltraSlot Treadsafe	34
Slotdrain Fittings and Accessories	36
Systems Design	40
Hydraulic and Drainage Systems Design	41
Water Storage and Flow Regulation	42
Flow Regulators	44
Design Formulae	46
Spillage Interception and Sheet Flow	48
Channel Configuration	49
Structural Design	50
Steel Reinforcing	51
Specification Clause	52
Further Resources	53
Handling, Installation and Maintenance	54
Typical Installations – FacadeSlot	55
Typical Installations – PaveSlot	56
Typical Installations – UniSlot	57
Typical Installations – CastSlot 8 & 28	58
Typical Installations – UltraSlot (including Treadsafe)	59
Typical Installations – Accessories	60
Jointing Details	61
Forming a Radius	64
Positioning Access Units	65
Channel Size Options	66

More Slotdrain. Less visible drainage.

More flexibility.

Less pipework.

More help with design. Less time on site.



Dover Priory Station
PaveSlot



Princesshay, Exeter
Devon
UniSlot



Guinness Packaging
Runcorn
UltraSlot

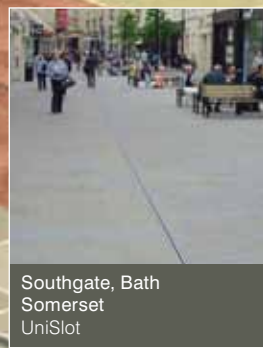

Southgate, Bath
Somerset
UniSlot

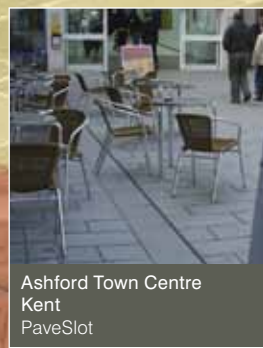

Ashford Town Centre
Kent
PaveSlot

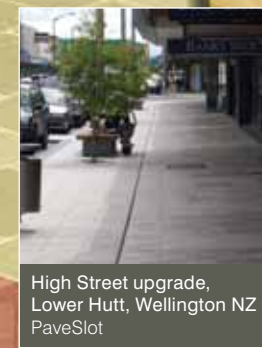

High Street upgrade,
Lower Hutt, Wellington NZ
PaveSlot



Norman Road Retail Park
Ashford, Kent
UniSlot



St. George's Quarter
Huddersfield
PaveSlot



Lombardy Retail Park
Hayes, Middlesex
UniSlot



Marina, Yas Island
UAE
PaveSlot

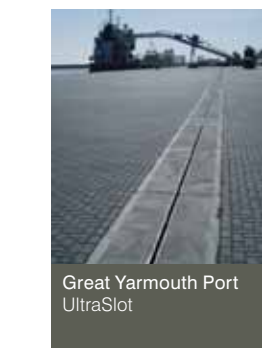

Great Yarmouth Port
UltraSlot



Sainsbury's, Faversham
Kent
CastSlot



UltraSlot



CastSlot

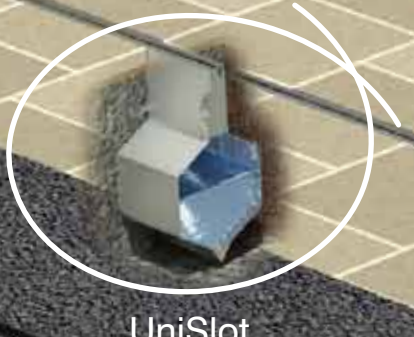

UniSlot



PaveSlot

- Quick and simple installation
- Minimal visual impact
- Strong, durable and impact resistant
- Comprehensive range
- Rapid design service
- Free design software

Minimal visual impact

Slotdrain's continuous intake slot is the only outward indication of the highly efficient surface water drainage system that lies just out of sight.

Easy and quick to install

Gatic Slotdrain comes in convenient 3 metre prefabricated lengths designed to keep below-ground pipework to a bare minimum, thus reducing installation time and holding down both labour and materials costs. While the system is straightforward to set to line and level, curves can be readily achieved using optional 1 metre or 500 mm sections.

Feet at the ends of each section, make Slotdrain easy to anchor in the trench and allow a single block of concrete to be poured under and around the main body of the channel, for maximum strength and integrity.

Comprehensive range

Slotdrain's range of sizes and load bearing capacities make it ideal for all kinds of applications, from residential, commercial and landscaping schemes to the most demanding of heavy industrial and transport projects.

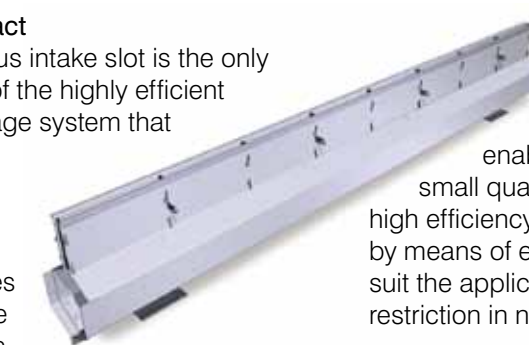

Water attenuation

A primary feature of our Slotdrain design is its unusual profile, which enables it to handle large or small quantities of water with similar high efficiency. Flow regulation is achieved by means of endplates with orifices sized to suit the application and positioned to avoid restriction in normal flow conditions.

Our design software enables systems to exactly match permissible discharge rates at each site. This feature can be particularly useful on sloping sites, where water can be retained at any level, thus avoiding local flooding in the discharge area.

Rapid response design service

Our dedicated team can usually turn round the design of a Slotdrain system, complete with quantities and delivery timescales within 24 hours.

FREE software

To make life even easier, we can supply you with our state-of-the-art design software so that you can plan your own Slotdrain system.

Straightforward and intuitive to use, it's the same software developed for and used by our own in-house design team.

Bespoke capability

If your project requirements can't be achieved with the use of our comprehensive, standard range of products or you have a particularly unusual problem to overcome, the Slotdrain concept is sufficiently flexible and adaptable to easily allow the design



and manufacture of custom components for bespoke systems. Just talk to our design team.

Proven Performance

Gatic Slotdrain fully complies with BS EN 1433:2002 (Drainage Channels for Vehicular and Pedestrian Areas). Certificates are available upon request.

Case studies

Please visit the 'Case Studies' section of the website for details of projects where Gatic Slotdrain has been used. These highlight the benefits and savings that can be achieved by using the system.



Glasgow Fort Retail Park
UniSlot



Valencia Airport
Spain
UltraSlot



LG Arena, NEC Centre
Birmingham
PaveSlot



Less pipework.

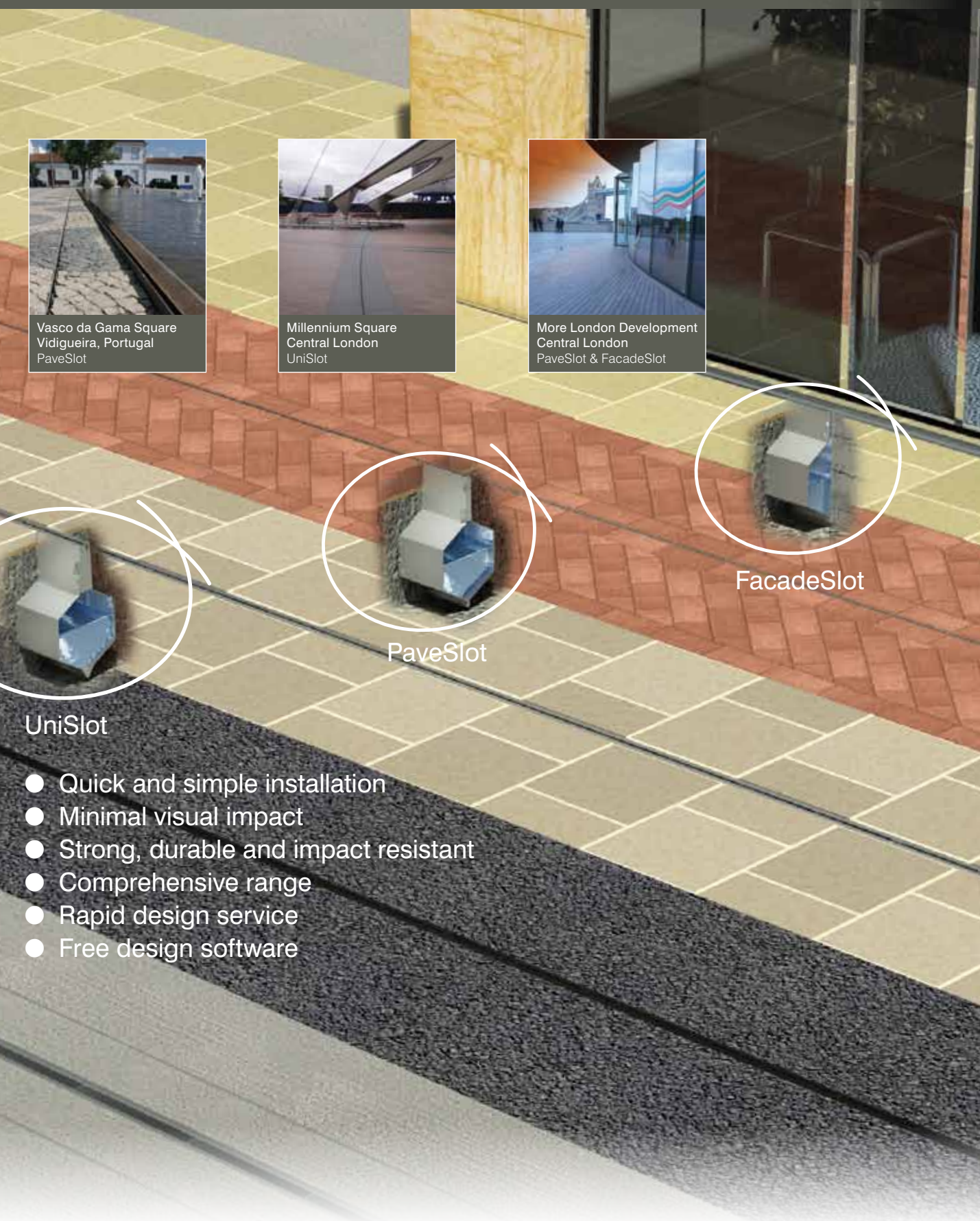

Vasco da Gama Square
Vidigueira, Portugal
PaveSlot

Millennium Square
Central London
UniSlot

More London Development
Central London
PaveSlot & FacadeSlot

- UniSlot**
- Quick and simple installation
 - Minimal visual impact
 - Strong, durable and impact resistant
 - Comprehensive range
 - Rapid design service
 - Free design software

More features. More benefits.

Performance benefits

- Strong and durable
- Watertight
- Rigid steel lining
- High capacity
- Stepped fall & self-cleansing
- Maximum intake
- Continuous interception (reduced wash-over)
- Fewer channel joints

Installation benefits

- Time and cost savings
- Quick installation
- Easy to handle
- Impact resistant
- High quality finish



Client benefits

- Reduced maintenance cost
- Safe system
- Tamper proof
- No moveable parts

Design benefits

- Simple system, quick design
- Precise and aesthetic
- Design flexibility
- Proven performance
- Quality assurance

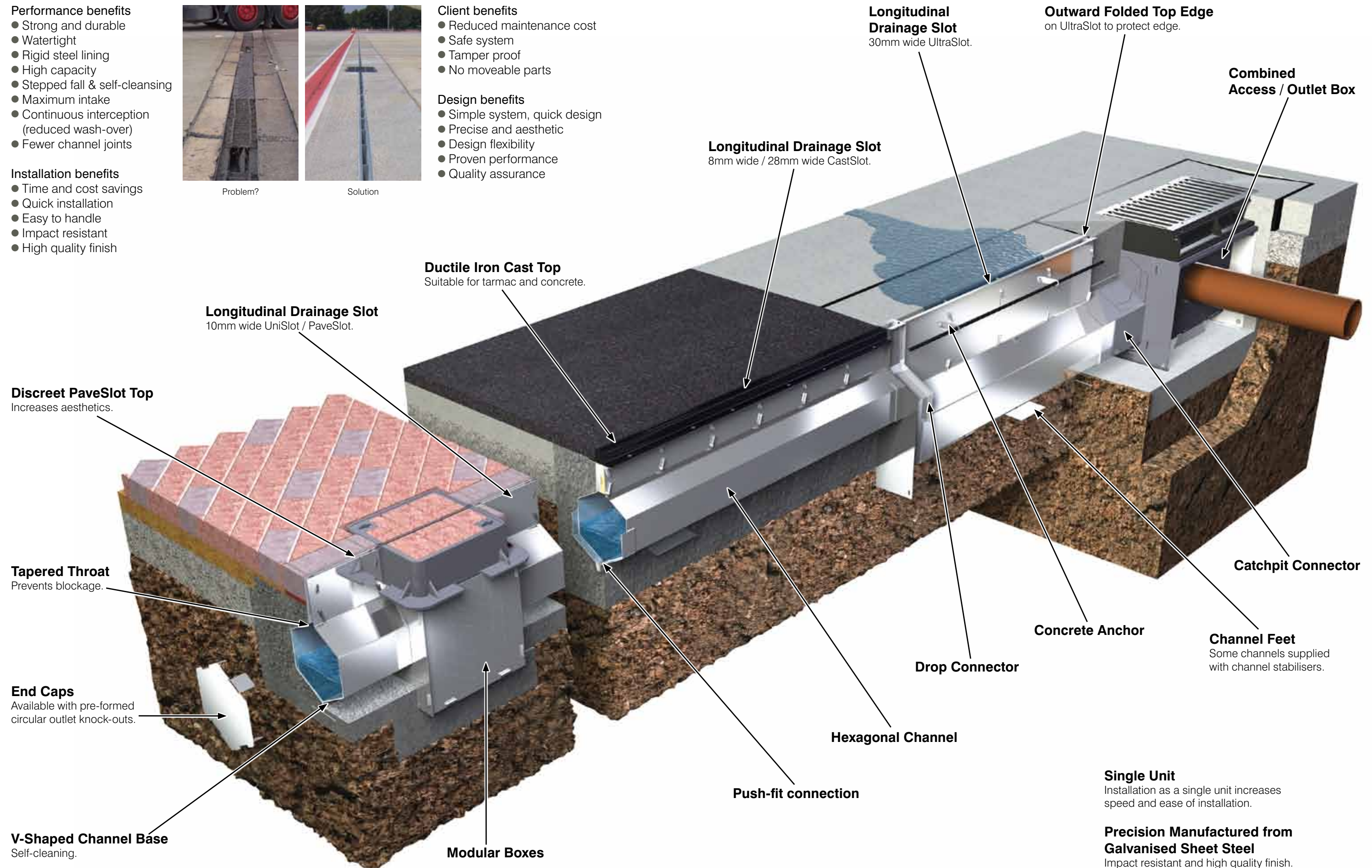

Single Unit
Installation as a single unit increases speed and ease of installation.

Precision Manufactured from Galvanised Sheet Steel
Impact resistant and high quality finish.



The Quality Management System of Gatic has been approved and accredited to BS EN ISO 9000:2008. Approved Certificate No. LRQ 0860814



Gatic has achieved the Kitemark standard for Gatic Slotdrain.



All Gatic Slotdrain products are CE Marked.

Quality Assurance

Gatic Slotdrain channels have been tested in accordance with recognised standards, providing reassurance to industry professionals that the system is fit for purpose. The system has proven performance, having been used successfully for many years on a variety of project types in many locations around the world.

Load Testing Standards

The only internationally recognised standard written specifically for trench drainage and slot drain systems is the European Standard EN 1433:2002 'Drainage Channels for Vehicular and Pedestrian Areas'. This uses the load classifications between A15-F900, as listed in the table below.

Load Tests

Gatic Slotdrain channels have been independently load tested up to F900kN (depending on the system type) in compliance with the European Standard EN 1433: 2002. Certificates of conformity are available upon request.

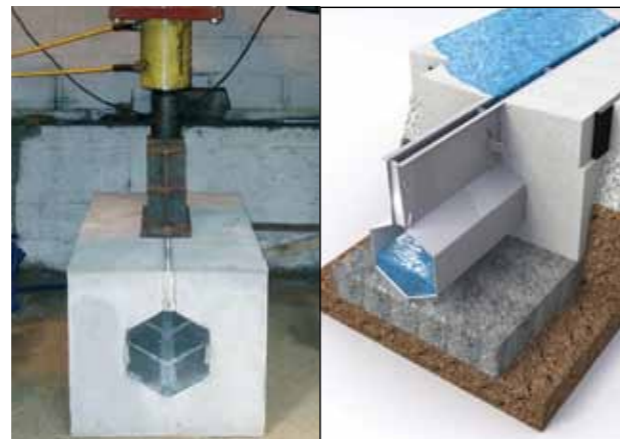

Watertight Slot Channels

Gatic Slotdrain has been independently tested for 'watertightness' and complies with the European Standard EN 1433:2002 – 'Drainage Channels for Vehicular and Pedestrian Areas' – when installed within a channel concrete encasement/surround according to manufacturer's details.

	 Load Class Gatic A15	 Load Class Gatic B125	 Load Class Gatic C250	 Load Class Gatic D400	 Load Class Gatic E600	 Load Class Gatic F900
	Load Ratings					
Trench Width						
100mm	482Nm	4kNm	8kNm	12kNm	19kNm	28kNm
200-300mm	400Nm	3kNm	6.5kNm	10kNm	16kNm	24kNm
Over 400mm	303Nm	2.5kNm	5kNm	8kNm	12kNm	18kNm
	Typical Uses					
	Light duty pedestrian traffic	Pavements, driveways and small private car parks	Heavy duty pedestrian traffic, occasional use by domestic and light duty commercial vehicles	Commercial projects, public pedestrian areas, slow moving vehicles	Industrial areas, light commercial forklifts	Airports, docks, industrial applications, fast moving traffic on highways, etc



Catering for Pedestrians with Disabilities

Gatic Slotdrain can run perpendicular to the main direction of traffic, with an open slot of only 10mm. This prevents wheelchairs or walking aids becoming trapped in the slot. UltraSlot Treadsafe also displays openings of only 9mm.



The discreet slot design prevents narrow wheels from becoming trapped.



Environmental Issues

Construction industry professionals around the world are becoming ever more conscious of the need for environmentally friendly construction methods, practices and products. National regulations and clients' individual environmental requirements further reinforce this trend.

Environmental Standards Compliance

Gatic's Environmental Management System has been approved and accredited to ISO 14001: 2004

Energy Consumption

Gatic Slotdrain is mechanically assembled, which eliminates welding and minimises energy usage in the manufacturing process.

Recycled Content

Gatic Slotdrain channels, accessories and components are manufactured from materials including galvanised steel, ductile iron and plastics. A significant proportion of these raw materials used are from recycled sources. Every effort is made to maximise recycled content.



Sustainability

Materials that are 100% recyclable again and again, such as steel, already possess an important characteristic of sustainability. Steel makers recycle scrap steel either by re-melting it in the electric arc furnace method (EAF) or by mixing it with molten iron ore in the BF-BOS¹ method. EAF can use up to 100% scrap, BF-BOS uses 10-25% scrap, and the overall average content for steel is 55%. With the present configuration of furnaces in the world today, 35% of steel is made by the EAF method and the remainder by BF-BOS. All steel is recyclable and will be multicycled many times without any artificial stimulus.

Recyclable

Manufactured from sheet steel, Gatic Slotdrain is 100% recyclable.

BREEAM

BREEAM is the world's foremost environmental assessment method and rating system for buildings.

Design teams use BREEAM as a method to improve the performance of their buildings and their own experience and knowledge of environmental aspects of sustainability.

Gatic Slotdrain has been used on a number of projects that have been associated with BREEAM, and it has been proven as a successful addition in each case.

Leadership in Energy & Environmental Design (LEED)

LEED provides guidelines designed to produce more energy efficient and environmentally sensitive buildings. Gatic Slotdrain can assist in the assignment of credits based on the LEED rating system.

¹BF-BOS: Blast furnace-Basic oxygen steelmaking

More products. More applications.

Landscaping and Pedestrian Schemes, like this one in Bath, are perfect applications for **Gatic FacadeSlot, PaveSlot and UniSlot**.

Others can be found throughout the world, from Ashford, Kent to Wellington, New Zealand.

Loading: from A15 to D400



In **Car Parks**, constant traffic can damage more traditional drainage systems.

With its minimal surface disruption and positive anchoring, **Gatic CastSlot** copes easily.

Loading: from A15 to D400



Highways and Motorways are under constant strain of heavy traffic.

Here only the strength of **Gatic CastSlot or UltraSlot** will do.

Loading: from A15 to F900



Distribution Yards and Industrial Units, typically have a large surface area to drain and must cope with heavy loads manoeuvring on a daily basis.

Gatic CastSlot or UltraSlot are the best choice.

Loading: from A15 to F900



Shopping Centres and Retail Parks. Unobtrusive but effective drainage in an attractive environment is the key here.

Gatic FacadeSlot, PaveSlot and UniSlot are the perfect solution.

Loading: from A15 to D400



Petrol Filling Stations and Forecourts mean wide open spaces and constant flow of traffic.

Ideal environments for **Gatic CastSlot or UltraSlot**.

Loading: from A15 to F900



Bus Terminals and Public Transport Facilities place heavy demands on surfaces and infrastructure.

Here the strength and integrity of **Gatic CastSlot and UltraSlot** provide long-term performance.

Loading: from A15 to F900



Container Ports and Distribution Yards are extremely hostile environments, pounded continuously by tractor and trailer units.

Products such as **Gatic CastSlot and UltraSlot** have been specifically developed with this in mind.

Loading: from A15 to F900



Large Ports and Dock Facilities place such high demands on below-ground structures such as drainage that only the products with the highest specification are fit for purpose.

Gatic CastSlot and UltraSlot are hard to beat.

Loading: from A15 to F900



Airports around the world are seeing aircraft movements increase year on year and aircraft weights reaching new heights. With Superjumbos like the Airbus A380 coming on stream, airside drainage is ever more of a challenge.

No wonder **Gatic UltraSlot** is the first choice for airports.

Loading: from A15 to F900



Fundamental to all Slotdrain channels is the unique hexagonal profile developed by Gatic to ensure our systems handle everything from a rain drop to a rainstorm with similarly high efficiency. The V- shaped channel base also encourages a self – cleansing flow through the channel and a tapered throat helps to prevent blockages.

The current Slotdrain range consists of five categories of channel, providing a suitable solution for any conceivable combination of drainage demand and loading requirement.

All our channels come in a variety of sizes and have an accompanying range of accessories and fittings to achieve total design flexibility. Full details can be found on the Gatic website www.gatic.com.

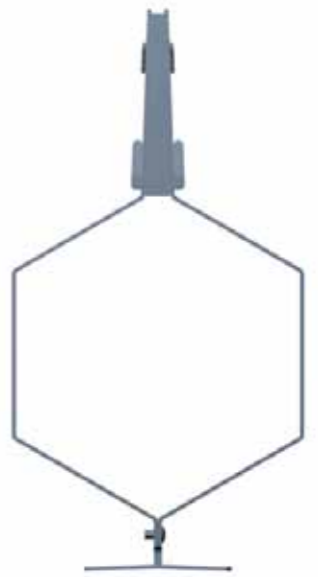

Characteristic Slotdrain profile.

- * All channels are manufactured from pre-galvanised sheet steel.
- * CastSlot is complete with ductile iron throat guard.
- * All channels are available in stainless steel (various grades).
- * Bespoke units are available to suit your design requirements.

Gatic FacadeSlot

A discreet surface drainage channel that can be installed directly against a building, wall or other external landscape feature, to provide effective drainage of surface liquids from vertical surfaces, door thresholds and the adjacent pavement area. FacadeSlot channels can be made to follow the building perimeter whether straight or curved.

The system can accommodate rainwater downpipes which, when positioned over a simple rainwater inlet box, can eliminate the need for a separate drainage network for the roof area, achieving a more efficient drainage design.

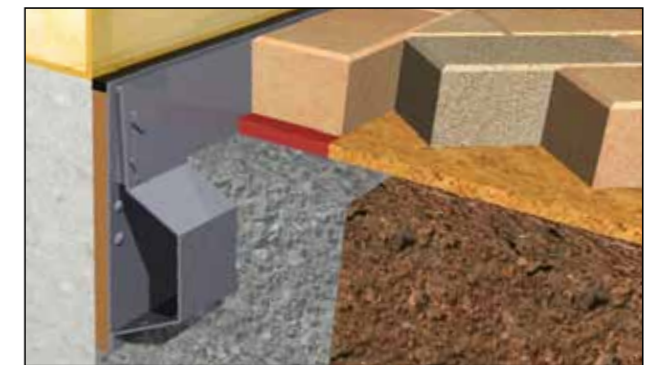

Load Classification: A15 (Bespoke units can be made which are suitable for up to D400)
Available channel widths:
 50mm, 75mm, 115mm

Applications:

- * Shopping Centres
- * High Security Areas
- * Building Exteriors
- * Schools
- * Pedestrian & Landscape Areas



Gatic PaveSlot

PaveSlot is used to drain external hard surface areas where a neat, unobtrusive and aesthetic appearance is required. The system is typically used with paving units laid against the top edge of the channel.

Throat spacer perforations allow any subsurface water that may have settled under paving units beside the channel to percolate and move into the channel body.

The system is suitable for all paved areas, in public and commercial projects, which may be subject to occasional traffic by delivery and service vehicles.

Load Classification:
A15 to D400

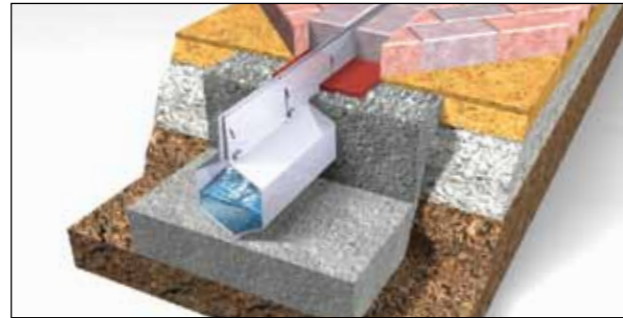

Available channel widths: 100mm, 150mm, 225mm, 300mm, 400mm, 500mm, 600mm

Applications:

- * Car Parks (with paving finish)
- * Shopping Centres
- * High Security Areas
- * Schools
- * Pedestrian & Landscape Areas
- * Building Exteriors

Gatic UniSlot

UniSlot, as its name suggests, is a universal surface drainage system designed to bring the benefits of the Slotdrain principle to projects using almost any kind of surface material, including paving, asphalt, tarmac and concrete.

The system is suitable for all external paved areas on public and commercial sites which may be subject to frequent traffic by regular delivery and service vehicles.

Load Classification: A15 to D400

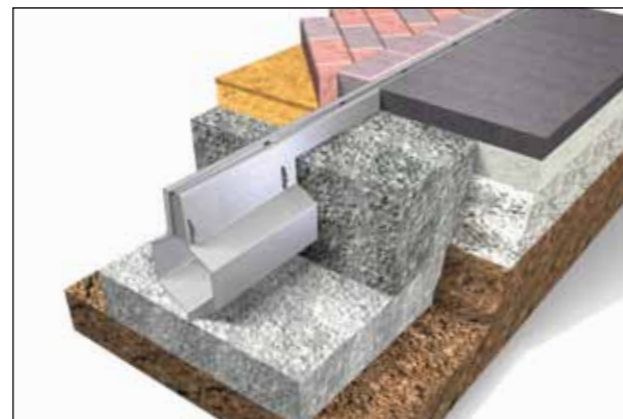

Available channel widths: 100mm, 150mm, 225mm, 300mm, 400mm, 500mm, 600mm

Applications:

- * Shopping Centres
- * High Security Areas
- * Building Exteriors
- * Schools
- * Pedestrian & Landscape Areas
- * Car Parks
- * Loading Areas

Gatic CastSlot 8 and 28

The unobtrusive profile of CastSlot sits neatly within asphalt and concrete surface finishes. The latest addition to the Gatic Slotdrain family of high performance surface water drainage systems, CastSlot features either a 'Treadsafe' 8mm ductile iron throat section or a 28mm ductile iron throat section, which is securely fixed to the galvanised steel channel body to provide an exceptionally robust yet discreet drainage system.

CastSlot is ideal for areas of vehicular traffic such as car parks and industrial units where there is slow turning traffic.

Load Classification:
A15 to F900

All CastSlot tops and associated ductile iron accessories are supplied electropainted.

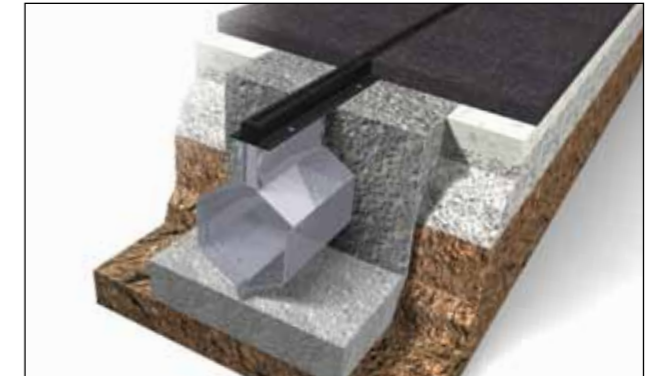
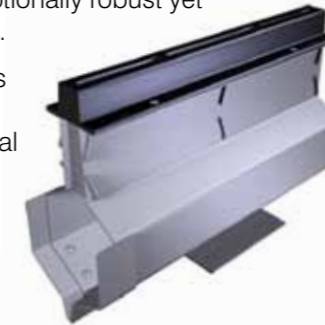

Available channel widths: 100mm, 150mm, 225mm, 300mm, 400mm, 500mm, 600mm

Applications:

- * Car Parks & Lorry Parks
- * Warehouses & Industrial Buildings
- * Highways
- * High Security Areas

Gatic UltraSlot and UltraSlot Treadsafe

UltraSlot is used in external pavement areas which are subject to constant traffic, such as airports, ports, highways and similar areas with heavy duty vehicles. Installed in a full concrete surround, the system is designed to ensure sufficient depth of concrete cover over the main body of the channel to withstand ultra heavy-duty loads.

The channel top edge has an outward fold for protection over the edge of the concrete encasement/surround to prevent damage. Innovative channel features, concrete anchors, stabilising bars, channel feet and others, ensure the channel has a physical connection to steel reinforcing and is properly tied into the concrete encasement/surround, to create a strong, solid and durable structure.

UltraSlot Treadsafe Bar:

A Treadsafe Bar can be fitted to the UltraSlot channel, which reduces the slot opening from 30mm wide to 2x9mm wide slots. This has no effect on the intake capacity of the system but will make the channel safe to cross for pedestrians.

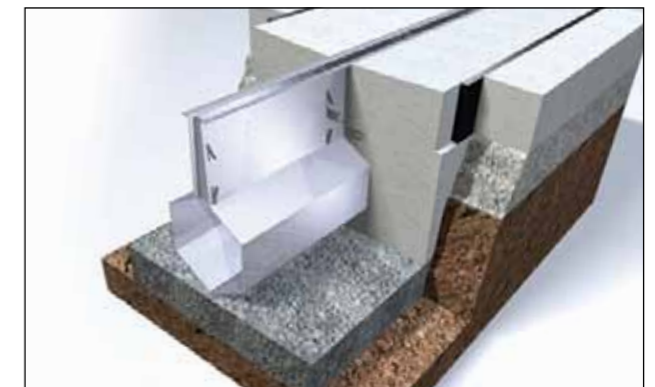

Load Classification: A15 to F900

Available channel widths: 150mm, 225mm, 300mm, 400mm, 500mm, 600mm

Applications:

- * Airports (airside and landside)
- * Highways
- * Ports & Docks
- * Petrol Stations
- * Military Bases
- * Terminal Buildings
- * High Security Areas
- * Warehouse & Industrial Buildings

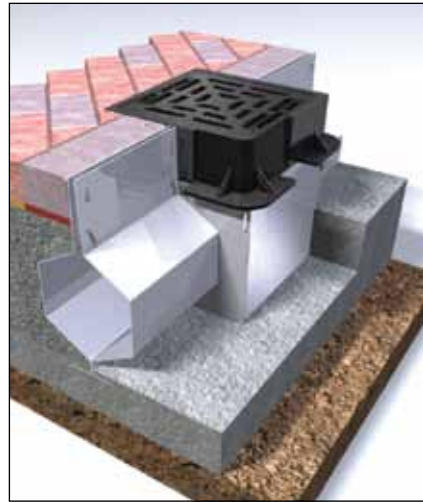

A comprehensive range of access, outlet and silt boxes is available to suit every conceivable system design consideration. The selection shown here is representative of the much larger variety available, details of which can be found in the product selector pages of this brochure as well as on our website www.gatic.com.

Similarly, the range of standard accessories (shown opposite) is available to suit all types and sizes of Slotdrain channels.

Bespoke fittings can also be made available upon request.

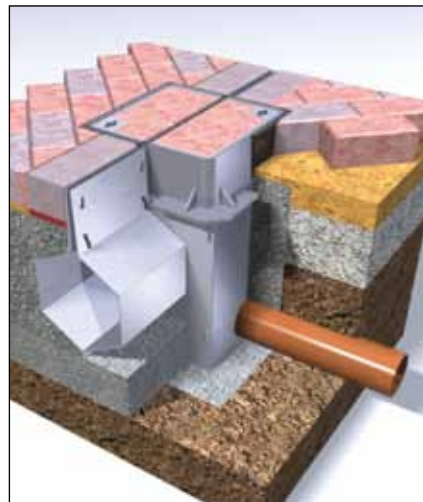

Outlet box – shown with recessed cover



Access box – shown with grating



Ultra heavy duty outlet unit



Silt box – shown with PaveSlot recessed cover

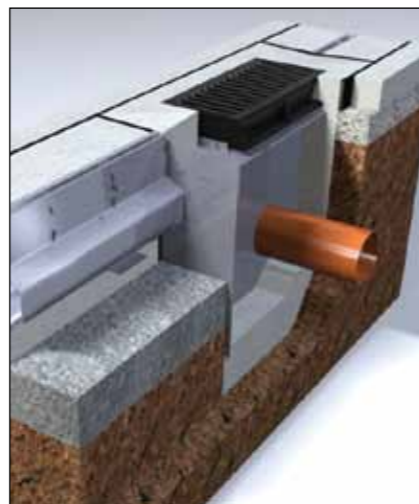
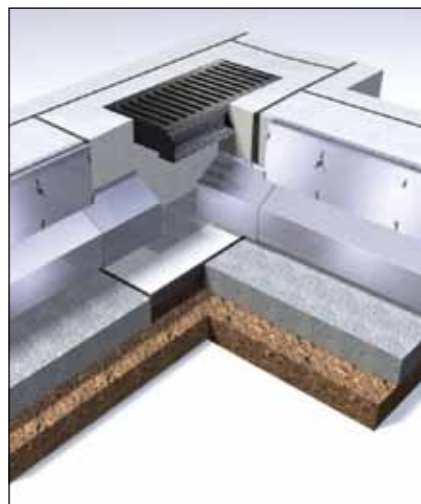
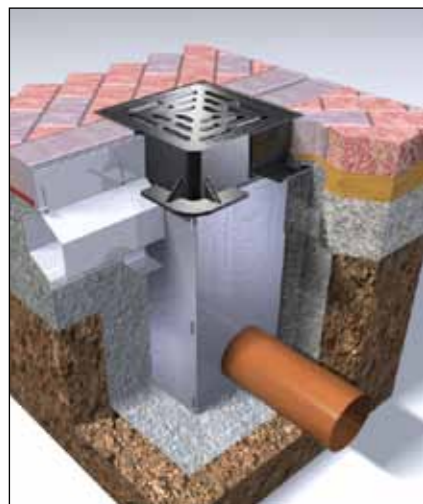

* Covers and gratings on small boxes are delivered with locking bolts.
 * Gratings with large boxes are supplied without locking bolts, but these can be added as an optional extra.



Drop connector (type 1)



Universal channel pipes



Drop connector (type 2)



End caps

End cap outlets

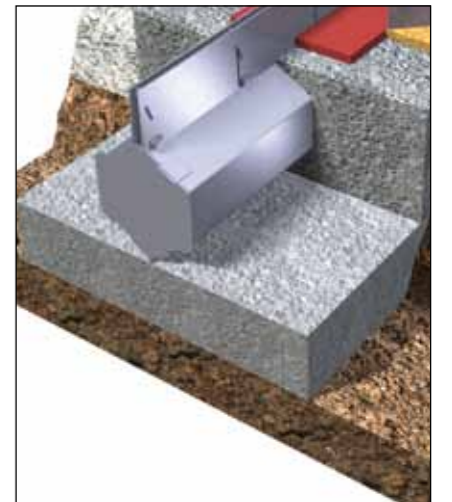

Universal catch pit connectors

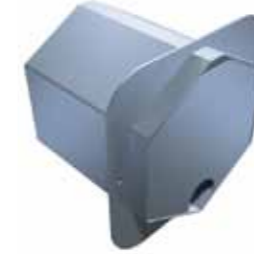

Flow regulators

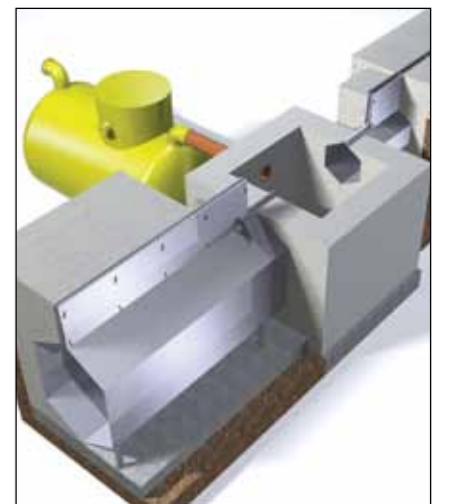
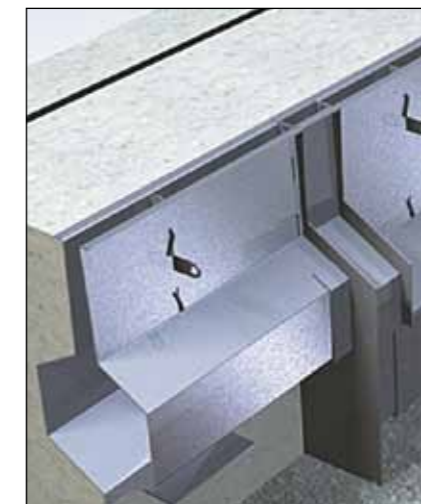
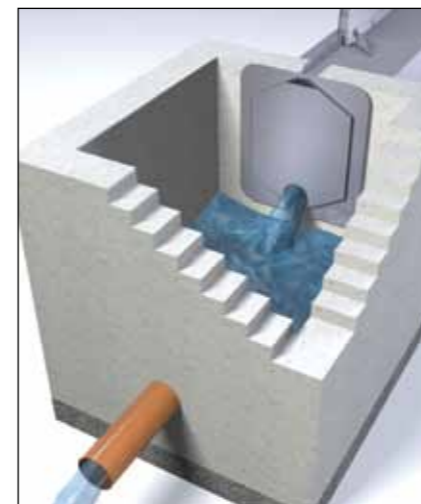



FACADESLOT 3m CHANNELS

Code	Description	Load Rating	Length (l) (mm)	Width (w) (mm)	Depth (d) (mm)	Invert (i) (mm)	Throat Depth (T1) (mm)	Throat Width (T2) (mm)	Slot Orifice (o) (mm)	Intake Area/Metre (mm ²)	Weight (kg)
S16305	50mm FacadeSlot – 3m	A15	3000	50	242	204	100	10	10	10000	24
S16310	75mm FacadeSlot – 3m	A15	3000	75	299	261	100	10	10	10000	31
S16315	115mm FacadeSlot – 3m	A15	3000	115	389	351	100	10	10	10000	42



FACADESLOT 1m CHANNELS

Code	Description	Load Rating	Length (l) (mm)	Width (w) (mm)	Depth (d) (mm)	Invert (i) (mm)	Throat Depth (T1) (mm)	Throat Width (T2) (mm)	Slot Orifice (o) (mm)	Intake Area/Metre (mm ²)	Weight (kg)
S16105	50mm FacadeSlot – 1m	A15	1000	50	242	204	100	10	10	10000	9
S16110	75mm FacadeSlot – 1m	A15	1000	75	299	261	100	10	10	10000	11
S16115	115mm FacadeSlot – 1m	A15	1000	115	389	351	100	10	10	10000	14



FACADESLOT 500mm CHANNELS

Code	Description	Load Rating	Length (l) (mm)	Width (w) (mm)	Depth (d) (mm)	Invert (i) (mm)	Throat Depth (T1) (mm)	Throat Width (T2) (mm)	Slot Orifice (o) (mm)	Intake Area/Metre (mm ²)	Weight (kg)
S16505	50mm FacadeSlot – 500mm	A15	500	50	242	204	100	10	10	10000	4
S16510	75mm FacadeSlot – 500mm	A15	500	75	299	261	100	10	10	10000	6
S16515	115mm FacadeSlot – 500mm	A15	500	115	389	351	100	10	10	10000	7



FACADESLOT SYSTEM END CAPS

Code	Description	To suit channel widths	Depth (d) (mm)	Invert (i) (mm)	Weight (kg)
S46120	FacadeSlot End Cap 50mm	50mm	145	204	0.2
S46125	FacadeSlot End Cap 75mm	75mm	201	261	0.3
S46130	FacadeSlot End Cap 115mm	115mm	284	351	0.6



FACADESLOT SYSTEM ACCESS POINTS

Code	Description	Load Rating	To suit channel widths (mm)	Depth (d) (mm)	Width (w) (mm)	Length (l) (mm)	Weight (kg)
S20320	Access Point to suit 50-75mm FacadeSlot c/w Recessed Cover	A15	50 & 75	305	259	259	11
S20330	Access Point to suit 115mm FacadeSlot c/w Recessed Cover	A15	115	390	259	259	12



FACADESLOT SYSTEM OUTLET BOXES

Code	Description	Load Rating	To suit channel widths (mm)	Depth (d) (mm)	Width (w) (mm)	Length (l) (mm)	Weight (kg)
S20220	Outlet Box to suit 50-75mm FacadeSlot c/w Recessed Cover	A15	50 & 75	450	259	259	13
S20230	Outlet Box to suit 115mm FacadeSlot c/w Recessed Cover	A15	115	535	259	259	14



FACADESLOT SYSTEM COMBINED ACCESS/OUTLET BOXES

Code	Description	Load Rating	To suit channel widths (mm)	Depth (d) (mm)	Width (w) (mm)	Length (l) (mm)	Weight (kg)
S20225	Combined Access/Outlet Box to suit 50-75mm FacadeSlot	A15	50 & 75	325	169	334	8
S20235	Combined Access/Outlet Box to suit 115mm FacadeSlot	A15	115	415	169	334	10

Tight Radius and Odd Lengths

Channel units can be cut to accommodate a tight radius or to suit odd lengths; when used in a specific channel layout.

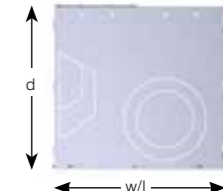
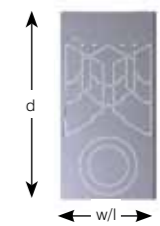
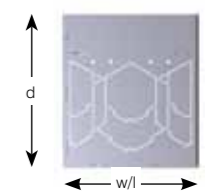
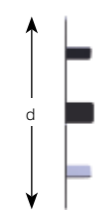
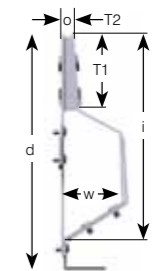
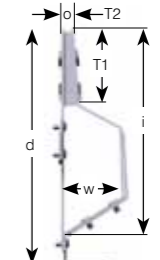
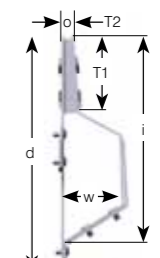

PAVESLOT 3M CHANNELS



Code	Description	Load Rating	Length (l) (mm)	Width (w) (mm)	Depth (d) (mm)		Invert (i) (mm)	Throat Depth (T1) (mm)	Throat Width (T2) (mm)	Slot Orifice (o) (mm)	Intake Area (mm ²)	Weight (kg)
S11305	100mm PaveSlot – 3m	D400	3000	100	251		211	98	10	10	10000	35
S11310	150mm PaveSlot – 3m	D400	3000	150	309		269	98	10	10	10000	46
S11315	225mm PaveSlot – 3m	D400	3000	225	444		404	148	10	10	10000	67
S11320	300mm PaveSlot – 3m	D400	3000	300	555		490	148	10	10	10000	85
S11325	400mm PaveSlot – 3m	D400	3000	400	666		606	148	10	10	10000	109
S11330	500mm PaveSlot – 3m	D400	3000	500	929		869	298	10	10	10000	148
S11335	600mm PaveSlot – 3m	D400	3000	600	1193		1133	298	10	10	10000	221

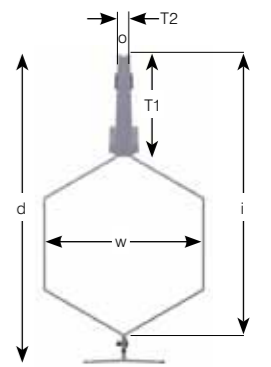

PAVESLOT 1m CHANNELS



Code	Description	Load Rating	Length (l) (mm)	Width (w) (mm)	Depth (d) (mm)		Invert (i) (mm)	Throat Depth (T1) (mm)	Throat Width (T2) (mm)	Slot Orifice (o) (mm)	Intake Area (mm ²)	Weight (kg)
S11105	100mm PaveSlot – 1m	D400	1000	100	251		211	98	10	10	10000	13
S11110	150mm PaveSlot – 1m	D400	1000	150	309		269	98	10	10	10000	16
S11115	225mm PaveSlot – 1m	D400	1000	225	444		404	148	10	10	10000	23
S11120	300mm PaveSlot – 1m	D400	1000	300	555		490	148	10	10	10000	31
S11125	400mm PaveSlot – 1m	D400	1000	400	666		606	148	10	10	10000	41
S11130	500mm PaveSlot – 1m	D400	1000	500	929		869	298	10	10	10000	54
S11135	600mm PaveSlot – 1m	D400	1000	600	1193		1133	298	10	10	10000	79

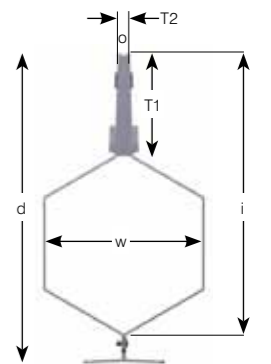

PAVESLOT 500mm CHANNELS



Code	Description	Load Rating	Length (l) (mm)	Width (w) (mm)	Depth (d) (mm)		Invert (i) (mm)	Throat Depth (T1) (mm)	Throat Width (T2) (mm)	Slot Orifice (o) (mm)	Intake Area (mm ²)	Weight (kg)
S11505	100mm PaveSlot – 500mm	D400	500	100	251		211	98	10	10	10000	7
S11510	150mm PaveSlot – 500mm	D400	500	150	309		269	98	10	10	10000	8
S11515	225mm PaveSlot – 500mm	D400	500	225	444		404	148	10	10	10000	12
S11520	300mm PaveSlot – 500mm	D400	500	300	555		490	148	10	10	10000	16
S11525	400mm PaveSlot – 500mm	D400	500	400	666		606	148	10	10	10000	23
S11530	500mm PaveSlot – 500mm	D400	500	500	929		869	298	10	10	10000	30
S11535	600mm PaveSlot – 500mm	D400	500	600	1193		1133	298	10	10	10000	43

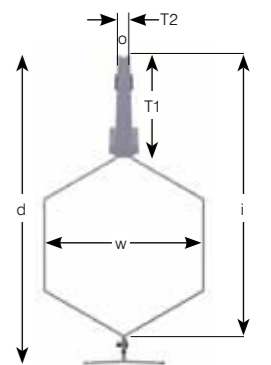

PAVESLOT DROP CONNECTORS



Type 1 Type 2

Code	Description	Type	From Channel		To Channel		Weight (kg)
			Width (mm)	Throat d (mm)	Width (mm)	Throat d (mm)	
S42400	100-150mm Drop Connector	1	100	100	150	100	0.4
S41400	150-225mm Drop Connector	2	150	100	225	150	5
S42410	225-300mm Drop Connector	1	225	150	300	150	1
S43410	300-400mm Drop Connector	1	300	150	400	150	3
S41405	400-500mm Drop Connector	2	400	150	500	300	13
S43420	500-600mm Drop Connector	1	500	300	600	300	7

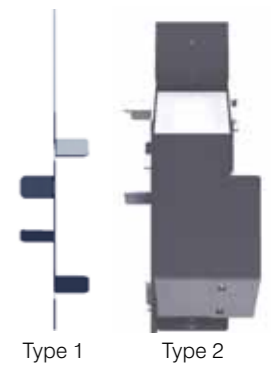

Type 1 Type 2

UNISLOT 3m CHANNELS



Code	Description	Load Rating		Length (l) mm	Width (w) mm	Depth (d) (mm)	Invert (i) (mm)	Throat Depth (T1) (mm)	Throat Width (T2) (mm)	Slot Orifice (o) (mm)	Intake Area/Metre (mm ²)	Weight (kg)
		Asphalt	Concrete									
S12305	100mm UniSlot – 3m	C250	D400	3000	100	251	211	105	30	10	10000	23
S12310	150mm UniSlot – 3m	C250	D400	3000	150	309	269	105	30	10	10000	29
S12315	225mm UniSlot – 3m	C250	D400	3000	225	445	404	155	30	10	10000	43
S12320	300mm UniSlot – 3m	C250	D400	3000	300	553	490	155	30	10	10000	54
S12325	400mm UniSlot – 3m	C250	D400	3000	400	665	606	155	30	10	10000	111
S12330	500mm UniSlot – 3m	C250	D400	3000	500	928	869	305	30	10	10000	151
S12335	600mm UniSlot – 3m	C250	D400	3000	600	1192	1133	305	30	10	10000	224

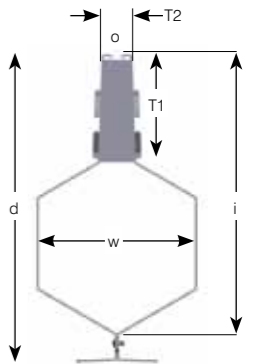

UNISLOT 1m CHANNELS



Code	Description	Load Rating		Length (l) mm	Width (w) mm	Depth (d) (mm)	Invert (i) (mm)	Throat Depth (T1) (mm)	Throat Width (T2) (mm)	Slot Orifice (o) (mm)	Intake Area/Metre (mm ²)	Weight (kg)
		Asphalt	Concrete									
S12105	100mm UniSlot – 1m	C250	D400	1000	100	251	211	105	30	10	10000	8
S12110	150mm UniSlot – 1m	C250	D400	1000	150	309	269	105	30	10	10000	11
S12115	225mm UniSlot – 1m	C250	D400	1000	225	445	404	155	30	10	10000	15
S12120	300mm UniSlot – 1m	C250	D400	1000	300	553	490	155	30	10	10000	20
S12125	400mm UniSlot – 1m	C250	D400	1000	400	665	606	155	30	10	10000	41
S12130	500mm UniSlot – 1m	C250	D400	1000	500	928	869	305	30	10	10000	55
S12135	600mm UniSlot – 1m	C250	D400	1000	600	1192	1133	305	30	10	10000	80

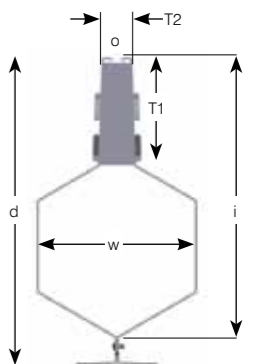

UNISLOT 500mm CHANNELS



Code	Description	Load Rating		Length (l) mm	Width (w) mm	Depth (d) (mm)	Invert (i) (mm)	Throat Depth (T1) (mm)	Throat Width (T2) (mm)	Slot Orifice (o) (mm)	Intake Area/Metre (mm ²)	Weight (kg)
		Asphalt	Concrete									
S12505	100mm UniSlot – 500mm	C250	D400	500	100	251	211	105	30	10	10000	4
S12510	150mm UniSlot – 500mm	C250	D400	500	150	309	269	105	30	10	10000	5
S12515	225mm UniSlot – 500mm	C250	D400	500	225	445	404	155	30	10	10000	8
S12520	300mm UniSlot – 500mm	C250	D400	500	300	553	490	155	30	10	10000	11
S12525	400mm UniSlot – 500mm	C250	D400	500	400	665	606	155	30	10	10000	24
S12530	500mm UniSlot – 500mm	C250	D400	500	500	928	869	305	30	10	10000	31
S12535	600mm UniSlot – 500mm	C250	D400	500	600	1192	1133	305	30	10	10000	43

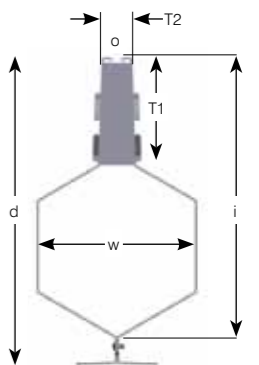

UNISLOT DROP CONNECTORS

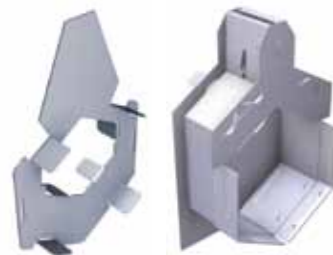

Type 1

Type 2

Code	Description	Type	From Channel		To Channel		Weight (kg)
			Width (mm)	Throat d (mm)	Width (mm)	Throat d (mm)	
S42400	100-150mm Drop Connector	1	100	100	150	100	0.4
S42405	150-225mm Drop Connector	2	150	100	225	150	3
S42410	225-300mm Drop Connector	1	225	150	300	150	1
S43410	300-400mm Drop Connector	1	300	150	400	150	3
S42420	400-500mm Drop Connector	2	400	150	500	300	14
S43420	500-600mm Drop Connector	1	500	300	600	300	7



Type 1

Type 2

CASTSLOT 8 D400 3m CHANNELS



Code	Description	Load Rating		Length (l) mm	Width (w) mm	Depth (d) (mm)	Invert (i) (mm)	Throat Depth (T1) (mm)	Throat Width (T2) (mm)	Slot Orifice (o) (mm)	Intake Area/Metre (m ²)	Weight (kg)
		Asphalt	Concrete									
S12306	100mm CastSlot 8 D400 – 3m	C250	D400	3000	100	252	211	105	40	8	7272	42
S12311	150mm CastSlot 8 D400 – 3m	C250	D400	3000	150	309	269	105	40	8	7272	48
S12316	225mm CastSlot 8 D400 – 3m	C250	D400	3000	225	443	404	155	40	8	7272	63
S12321	300mm CastSlot 8 D400 – 3m	C250	D400	3000	300	529	490	155	40	8	7272	72
S12326	400mm CastSlot 8 D400 – 3m	C250	D400	3000	400	666	606	155	40	8	7272	127
S12331	500mm CastSlot 8 D400 – 3m	C250	D400	3000	500	929	869	305	40	8	7272	167
S12336	600mm CastSlot 8 D400 – 3m	C250	D400	3000	600	1192	1133	305	40	8	7272	237

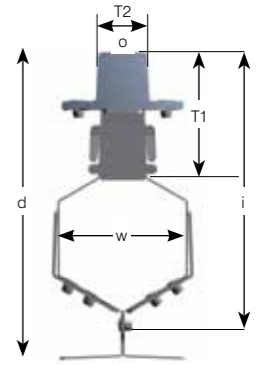

CASTSLOT 8 D400 1m CHANNELS



Code	Description	Load Rating		Length (l) mm	Width (w) mm	Depth (d) (mm)	Invert (i) (mm)	Throat Depth (T1) (mm)	Throat Width (T2) (mm)	Slot Orifice (o) (mm)	Intake Area/Metre (m ²)	Weight (kg)
		Asphalt	Concrete									
S12106	100mm CastSlot 8 D400 – 1m	C250	D400	1000	100	252	211	105	40	8	7272	15
S12111	150mm CastSlot 8 D400 – 1m	C250	D400	1000	150	309	269	105	40	8	7272	17
S12116	225mm CastSlot 8 D400 – 1m	C250	D400	1000	225	443	404	155	40	8	7272	23
S12121	300mm CastSlot 8 D400 – 1m	C250	D400	1000	300	529	490	155	40	8	7272	26
S12126	400mm CastSlot 8 D400 – 1m	C250	D400	1000	400	666	606	155	40	8	7272	47
S12131	500mm CastSlot 8 D400 – 1m	C250	D400	1000	500	929	869	305	40	8	7272	60
S12136	600mm CastSlot 8 D400 – 1m	C250	D400	1000	600	1192	1133	305	40	8	7272	84

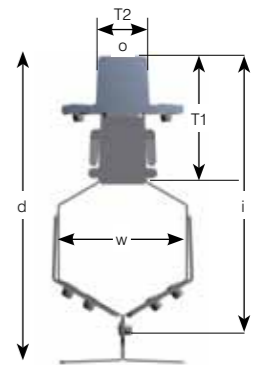

CASTSLOT 8 D400 500mm CHANNELS



Code	Description	Load Rating		Length (l) mm	Width (w) mm	Depth (d) (mm)	Invert (i) (mm)	Throat Depth (T1) (mm)	Throat Width (T2) (mm)	Slot Orifice (o) (mm)	Intake Area/Metre (m ²)	Weight (kg)
		Asphalt	Concrete									
S12506	100mm CastSlot 8 D400 – 500mm	C250	D400	500	100	252	211	105	40	8	7272	8
S12511	150mm CastSlot 8 D400 – 500mm	C250	D400	500	150	309	269	105	40	8	7272	9
S12516	225mm CastSlot 8 D400 – 500mm	C250	D400	500	225	443	404	155	40	8	7272	12
S12521	300mm CastSlot 8 D400 – 500mm	C250	D400	500	300	529	490	155	40	8	7272	14
S12526	400mm CastSlot 8 D400 – 500mm	C250	D400	500	400	666	606	155	40	8	7272	27
S12531	500mm CastSlot 8 D400 – 500mm	C250	D400	500	500	929	869	305	40	8	7272	33
S12536	600mm CastSlot 8 D400 – 500mm	C250	D400	500	600	1192	1133	305	40	8	7272	46

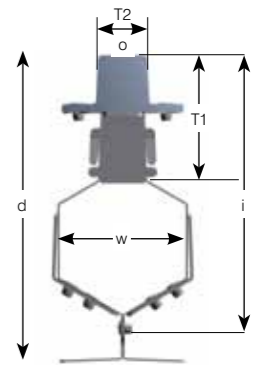

CASTSLOT 8 D400 DROP CONNECTORS



Type 1

Type 2

Code	Description	Type	From Channel		To Channel		Weight (kg)
			Width (mm)	Throat d (mm)	Width (mm)	Throat d (mm)	
S42400	100-150mm Drop Connector	1	100	100	150	100	0.4
S42430	150-225mm Drop Connector	2	150	100	225	150	4
S42410	225-300mm Drop Connector	1	225	150	300	150	1
S43410	300-400mm Drop Connector	1	300	150	400	150	3
S42435	400-500mm Drop Connector	2	400	150	500	300	14
S43420	500-600mm Drop Connector	1	500	300	600	300	7

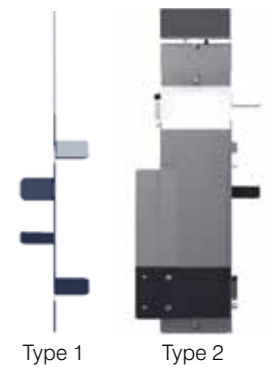

Type 1

Type 2

CASTSLOT 28 D400 3m CHANNELS



Code	Description	Load Rating		Length (l) mm	Width (w) mm	Depth (d) (mm)	Invert (i) (mm)	Throat Depth (T1) (mm)	Throat Width (T2) (mm)	Slot Orifice (o) (mm)	Intake Area/Metre (mm ²)	Weight (kg)
		Asphalt	Concrete									
S12307	100mm CastSlot 28 D400 – 3m	C250	D400	3000	100	252	211	105	40	28	25731	36
S12312	150mm CastSlot 28 D400 – 3m	C250	D400	3000	150	309	269	105	40	28	25731	42
S12317	225mm CastSlot 28 D400 – 3m	C250	D400	3000	225	443	404	155	40	28	25731	57
S12322	300mm CastSlot 28 D400 – 3m	C250	D400	3000	300	529	490	155	40	28	25731	66
S12327	400mm CastSlot 28 D400 – 3m	C250	D400	3000	400	666	606	155	40	28	25731	121
S12332	500mm CastSlot 28 D400 – 3m	C250	D400	3000	500	929	869	305	40	28	25731	160
S12337	600mm CastSlot 28 D400 – 3m	C250	D400	3000	600	1192	1133	305	40	28	25731	232

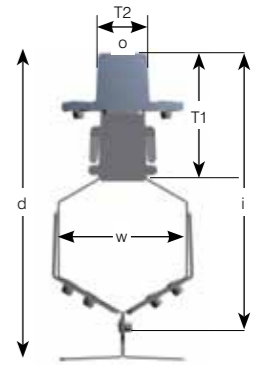

CASTSLOT 28 D400 1m CHANNELS



Code	Description	Load Rating		Length (l) mm	Width (w) mm	Depth (d) (mm)	Invert (i) (mm)	Throat Depth (T1) (mm)	Throat Width (T2) (mm)	Slot Orifice (o) (mm)	Intake Area/Metre (mm ²)	Weight (kg)
		Asphalt	Concrete									
S12107	100mm CastSlot 28 D400 – 1m	C250	D400	1000	100	252	211	105	40	28	25731	13
S12112	150mm CastSlot 28 D400 – 1m	C250	D400	1000	150	309	269	105	40	28	25731	16
S12117	225mm CastSlot 28 D400 – 1m	C250	D400	1000	225	443	404	155	40	28	25731	21
S12122	300mm CastSlot 28 D400 – 1m	C250	D400	1000	300	529	490	155	40	28	25731	24
S12127	400mm CastSlot 28 D400 – 1m	C250	D400	1000	400	666	606	155	40	28	25731	45
S12132	500mm CastSlot 28 D400 – 1m	C250	D400	1000	500	929	869	305	40	28	25731	58
S12137	600mm CastSlot 28 D400 – 1m	C250	D400	1000	600	1192	1133	305	40	28	25731	82

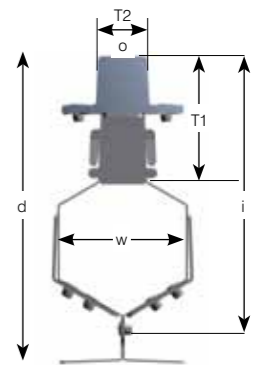

CASTSLOT 28 D400 500mm CHANNELS



Code	Description	Load Rating		Length (l) mm	Width (w) mm	Depth (d) (mm)	Invert (i) (mm)	Throat Depth (T1) (mm)	Throat Width (T2) (mm)	Slot Orifice (o) (mm)	Intake Area/Metre (mm ²)	Weight (kg)
		Asphalt	Concrete									
S12507	100mm CastSlot 28 D400 – 500mm	C250	D400	500	100	252	211	105	40	28	25731	7
S12512	150mm CastSlot 28 D400 – 500mm	C250	D400	500	150	309	269	105	40	28	25731	8
S12517	225mm CastSlot 28 D400 – 500mm	C250	D400	500	225	443	404	155	40	28	25731	11
S12522	300mm CastSlot 28 D400 – 500mm	C250	D400	500	300	529	490	155	40	28	25731	13
S12527	400mm CastSlot 28 D400 – 500mm	C250	D400	500	400	666	606	155	40	28	25731	26
S12532	500mm CastSlot 28 D400 – 500mm	C250	D400	500	500	929	869	305	40	28	25731	32
S12537	600mm CastSlot 28 D400 – 500mm	C250	D400	500	600	1192	1133	305	40	28	25731	45

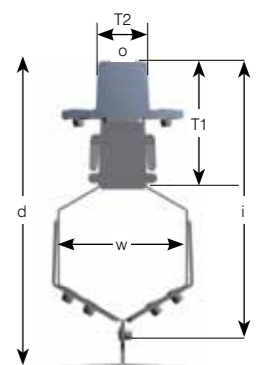

CASTSLOT 28 D400 DROP CONNECTORS



Type 1 Type 2

Code	Description	Type	From Channel		To Channel		Weight (kg)
			Width (mm)	Throat d (mm)	Width (mm)	Throat d (mm)	
S42400	100-150mm Drop Connector	1	100	100	150	100	0.4
S42440	150-225mm Drop Connector	2	150	100	225	150	4
S42410	225-300mm Drop Connector	1	225	150	300	150	1
S43410	300-400mm Drop Connector	1	300	150	400	150	3
S42445	400-500mm Drop Connector	2	400	150	500	300	14
S43420	500-600mm Drop Connector	1	500	300	600	300	7

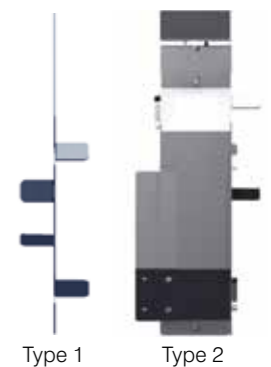

Type 1 Type 2



CASTSLOT 8 F900 3m CHANNELS

Code	Description	Load Rating Concrete	Length (l) mm	Width (w) mm	Depth (d) (mm)	Invert (i) (mm)	Throat Depth (T1) (mm)	Throat Width (T2) (mm)	Slot Orifice (o) (mm)	Intake Area/Metre (m ²)	Weight (kg)
S13306	150mm CastSlot 8 F900 – 3m	F900	3000	150	402	364	200	40	8	7272	55
S13311	225mm CastSlot 8 F900 – 3m	F900	3000	225	487	450	200	40	8	7272	66
S13316	300mm CastSlot 8 F900 – 3m	F900	3000	300	671	634	300	40	8	7272	85
S13321	400mm CastSlot 8 F900 – 3m	F900	3000	400	813	753	300	40	8	7272	145
S13326	500mm CastSlot 8 F900 – 3m	F900	3000	500	929	869	300	40	8	7272	166
S13331	600mm CastSlot 8 F900 – 3m	F900	3000	600	1192	1133	300	40	8	7272	238

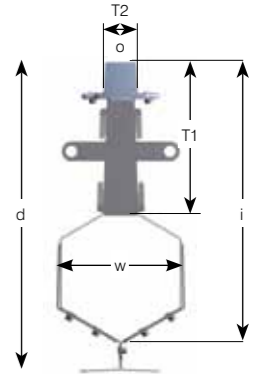

CASTSLOT 8 F900 1m CHANNELS

Code	Description	Load Rating Concrete	Length (l) mm	Width (w) mm	Depth (d) (mm)	Invert (i) (mm)	Throat Depth (T1) (mm)	Throat Width (T2) (mm)	Slot Orifice (o) (mm)	Intake Area/Metre (m ²)	Weight (kg)
S13106	150mm CastSlot 8 F900 – 1m	F900	1000	150	402	364	200	40	8	7272	19
S13111	225mm CastSlot 8 F900 – 1m	F900	1000	225	487	450	200	40	8	7272	24
S13116	300mm CastSlot 8 F900 – 1m	F900	1000	300	671	634	300	40	8	7272	31
S13121	400mm CastSlot 8 F900 – 1m	F900	1000	400	813	753	300	40	8	7272	53
S13126	500mm CastSlot 8 F900 – 1m	F900	1000	500	929	869	300	40	8	7272	60
S13131	600mm CastSlot 8 F900 – 1m	F900	1000	600	1192	1133	300	40	8	7272	85

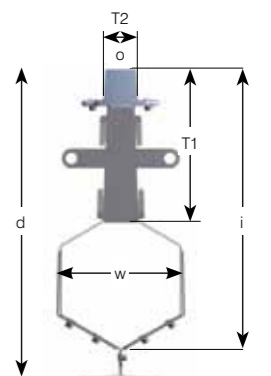

CASTSLOT 8 F900 500mm CHANNELS

Code	Description	Load Rating Concrete	Length (l) mm	Width (w) mm	Depth (d) (mm)	Invert (i) (mm)	Throat Depth (T1) (mm)	Throat Width (T2) (mm)	Slot Orifice (o) (mm)	Intake Area/Metre (m ²)	Weight (kg)
S13506	150mm CastSlot 8 F900 – 500mm	F900	500	150	402	364	200	40	8	7272	10
S13511	225mm CastSlot 8 F900 – 500mm	F900	500	225	487	450	200	40	8	7272	12
S13516	300mm CastSlot 8 F900 – 500mm	F900	500	300	671	634	300	40	8	7272	17
S13521	400mm CastSlot 8 F900 – 500mm	F900	500	400	813	753	300	40	8	7272	30
S13526	500mm CastSlot 8 F900 – 500mm	F900	500	500	929	869	300	40	8	7272	33
S13531	600mm CastSlot 8 F900 – 500mm	F900	500	600	1192	1133	300	40	8	7272	46

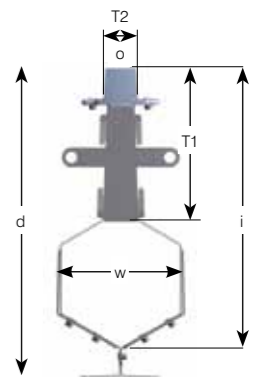

Type 1

Type 2

CASTSLOT 8 F900 DROP CONNECTORS

Code	Description	Type	From Channel		To Channel		Weight (kg)
			Width (mm)	Throat d (mm)	Width (mm)	Throat d (mm)	
S43400	150-225mm Drop Connector	1	150	200	225	200	1
S43425	225-300mm Drop Connector	2	225	200	300	300	6
S43410	300-400mm Drop Connector	1	300	300	400	300	3
S43415	400-500mm Drop Connector	1	400	300	500	300	4
S43420	500-600mm Drop Connector	1	500	300	600	300	7

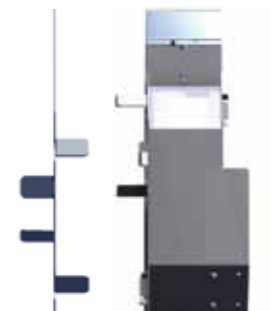

Type 1

Type 2

CASTSLOT 28 F900 3m CHANNELS



Code	Description	Load Rating Concrete	Length (l) mm	Width (w) mm	Depth (d) (mm)	Invert (i) (mm)	Throat Depth (T1) (mm)	Throat Width (T2) (mm)	Slot Orifice (o) (mm)	Intake Area/Metre (mm ²)	Weight (kg)
S13307	150mm CastSlot 28 F900 – 3m	F900	3000	150	402	364	200	40	28	25731	50
S13312	225mm CastSlot 28 F900 – 3m	F900	3000	225	487	450	200	40	28	25731	60
S13317	300mm CastSlot 28 F900 – 3m	F900	3000	300	671	634	300	40	28	25731	79
S13322	400mm CastSlot 28 F900 – 3m	F900	3000	400	813	753	300	40	28	25731	139
S13327	500mm CastSlot 28 F900 – 3m	F900	3000	500	929	869	300	40	28	25731	160
S13332	600mm CastSlot 28 F900 – 3m	F900	3000	600	1192	1133	300	40	28	25731	232

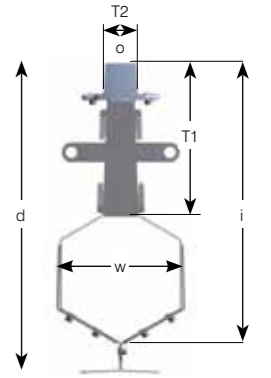

CASTSLOT 28 F900 1m CHANNELS



Code	Description	Load Rating Concrete	Length (l) mm	Width (w) mm	Depth (d) (mm)	Invert (i) (mm)	Throat Depth (T1) (mm)	Throat Width (T2) (mm)	Slot Orifice (o) (mm)	Intake Area/Metre (mm ²)	Weight (kg)
S13107	150mm CastSlot 28 F900 – 1m	F900	1000	150	402	364	200	40	28	25731	17
S13112	225mm CastSlot 28 F900 – 1m	F900	1000	225	487	450	200	40	28	25731	22
S13117	300mm CastSlot 28 F900 – 1m	F900	1000	300	671	634	300	40	28	25731	29
S13122	400mm CastSlot 28 F900 – 1m	F900	1000	400	813	753	300	40	28	25731	51
S13127	500mm CastSlot 28 F900 – 1m	F900	1000	500	929	869	300	40	28	25731	58
S13132	600mm CastSlot 28 F900 – 1m	F900	1000	600	1192	1133	300	40	28	25731	83

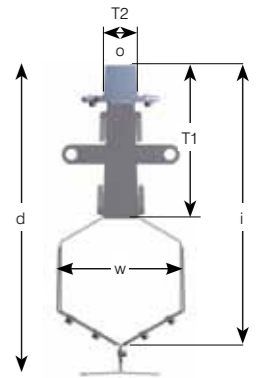

CASTSLOT 28 F900 500mm CHANNELS



Code	Description	Load Rating Concrete	Length (l) mm	Width (w) mm	Depth (d) (mm)	Invert (i) (mm)	Throat Depth (T1) (mm)	Throat Width (T2) (mm)	Slot Orifice (o) (mm)	Intake Area/Metre (mm ²)	Weight (kg)
S13507	150mm CastSlot 28 F900 – 500mm	F900	500	150	402	364	200	40	28	25731	9
S13512	225mm CastSlot 28 F900 – 500mm	F900	500	225	487	450	200	40	28	25731	11
S13517	300mm CastSlot 28 F900 – 500mm	F900	500	300	671	634	300	40	28	25731	16
S13522	400mm CastSlot 28 F900 – 500mm	F900	500	400	813	753	300	40	28	25731	29
S13527	500mm CastSlot 28 F900 – 500mm	F900	500	500	929	869	300	40	28	25731	32
S13532	600mm CastSlot 28 F900 – 500mm	F900	500	600	1192	1133	300	40	28	25731	45

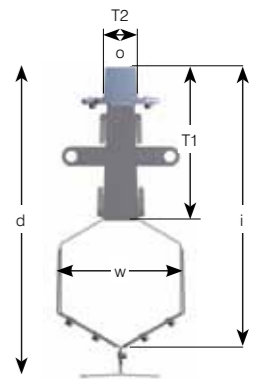

CASTSLOT 28 F900 DROP CONNECTORS

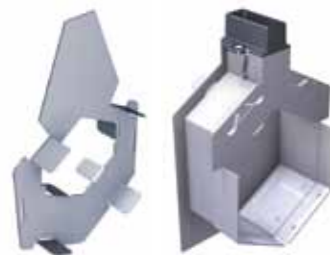

Type 1

Type 2

Code	Description	Type	From Channel		To Channel		Weight (kg)
			Width (mm)	Throat d (mm)	Width (mm)	Throat d (mm)	
S43400	150-225mm Drop Connector	1	150	200	225	200	1
S43430	225-300mm Drop Connector	2	225	200	300	300	6
S43410	300-400mm Drop Connector	1	300	300	400	300	3
S43415	400-500mm Drop Connector	1	400	300	500	300	4
S43420	500-600mm Drop Connector	1	500	300	600	300	7

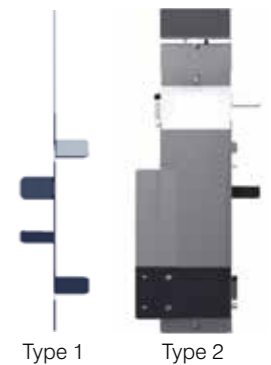

Type 1

Type 2

ULTRASLOT 3m CHANNELS



Code	Description	Load Rating	Length (l) (mm)	Width (w) (mm)	Depth (d) (mm)		Invert (i) (mm)	Throat Depth (T1) (mm)	Throat Width (T2) (mm)	Slot Orifice (o) (mm)	Intake Area (mm ²)	Weight (kg)
S12355	150mm UltraSlot Shallow Invert – 3m	D400	3000	150	310		269	104	70	30	30000	30
S13305	150mm UltraSlot – 3m	F900	3000	150	404		364	200	70	30	30000	37
S13310	225mm UltraSlot – 3m	F900	3000	225	490		450	200	70	30	30000	47
S13315	300mm UltraSlot – 3m	F900	3000	300	697		634	300	70	30	30000	67
S13320	400mm UltraSlot – 3m	F900	3000	400	810		750	300	70	30	30000	128
S13325	500mm UltraSlot – 3m	F900	3000	500	926		866	300	70	30	30000	148
S13330	600mm UltraSlot – 3m	F900	3000	600	1190		1129	300	70	30	30000	222

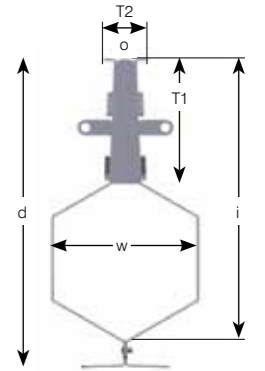

ULTRASLOT 1m CHANNELS



Code	Description	Load Rating	Length (l) (mm)	Width (w) (mm)	Depth (d) (mm)		Invert (i) (mm)	Throat Depth (T1) (mm)	Throat Width (T2) (mm)	Slot Orifice (o) (mm)	Intake Area (mm ²)	Weight (kg)
S12155	150mm UltraSlot Shallow Invert – 1m	D400	1000	150	310		269	104	70	30	30000	11
S13105	150mm UltraSlot – 1m	F900	1000	150	404		364	200	70	30	30000	13
S13110	225mm UltraSlot – 1m	F900	1000	225	490		450	200	70	30	30000	17
S13115	300mm UltraSlot – 1m	F900	1000	300	697		634	300	70	30	30000	25
S13120	400mm UltraSlot – 1m	F900	1000	400	810		750	300	70	30	30000	48
S13125	500mm UltraSlot – 1m	F900	1000	500	926		866	300	70	30	30000	55
S13130	600mm UltraSlot – 1m	F900	1000	600	1190		1129	300	70	30	30000	79

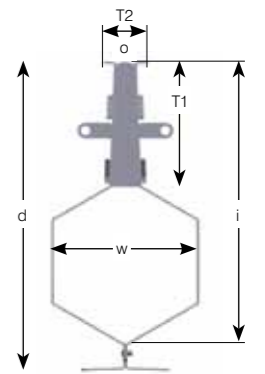

ULTRASLOT 500m CHANNELS



Code	Description	Load Rating	Length (l) (mm)	Width (w) (mm)	Depth (d) (mm)		Invert (i) (mm)	Throat Depth (T1) (mm)	Throat Width (T2) (mm)	Slot Orifice (o) (mm)	Intake Area (mm ²)	Weight (kg)
S12555	150mm UltraSlot Shallow Invert – 500m	D400	500	150	310		269	104	70	30	30000	6
S13505	150mm UltraSlot – 500m	F900	500	150	404		364	200	70	30	30000	7
S13510	225mm UltraSlot – 500m	F900	500	225	490		450	200	70	30	30000	9
S13515	300mm UltraSlot – 500m	F900	500	300	697		634	300	70	30	30000	14
S13520	400mm UltraSlot – 500m	F900	500	400	810		750	300	70	30	30000	27
S13525	500mm UltraSlot – 500m	F900	500	500	926		866	300	70	30	30000	31
S13530	600mm UltraSlot – 500m	F900	500	600	1190		1129	300	70	30	30000	43

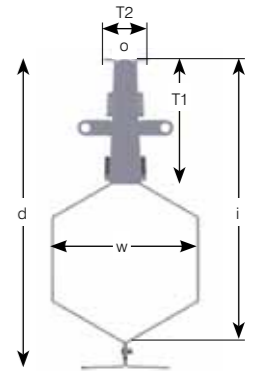

ULTRASLOT DROP CONNECTORS

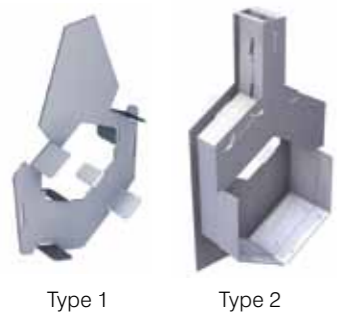

Code	Description	Type	From Channel		To Channel		Weight (kg)
			Width (mm)	Throat d (mm)	Width (mm)	Throat d (mm)	
S43400	150-225mm Drop Connector	1	150	200	225	200	1
S43405	225-300mm Drop Connector	2	225	200	300	300	5
S43406	225-300mm Drop Connector (Treadsafe)	2	225	200	300	300	5
S43410	300-400mm Drop Connector	1	300	300	400	300	3
S43415	400-500mm Drop Connector	1	400	300	500	300	4
S43420	500-600mm Drop Connector	1	500	300	600	300	7



ULTRASLOT TREADSAFE 3m CHANNELS



Code	Description	Load Rating	Length (l) (mm)	Width (w) (mm)	Depth (d) (mm)		Invert (i) (mm)	Throat Depth (T1) (mm)	Throat Width (T2) (mm)	Slot Orifice (o) (mm)	Intake Area (mm ²)	Weight (kg)
S12360	150mm UltraSlot Treadsafe Shallow Invert – 3m	D400	3000	150	310		269	104	70	2 x 9mm	30000	30
S13355	150mm UltraSlot Treadsafe – 3m	F900	3000	150	404		364	200	70	2 x 9mm	30000	37
S13360	225mm UltraSlot Treadsafe – 3m	F900	3000	225	490		450	200	70	2 x 9mm	30000	47
S13365	300mm UltraSlot Treadsafe – 3m	F900	3000	300	697		634	300	70	2 x 9mm	30000	67
S13370	400mm UltraSlot Treadsafe – 3m	F900	3000	400	810		750	300	70	2 x 9mm	30000	128
S13375	500mm UltraSlot Treadsafe – 3m	F900	3000	500	926		866	300	70	2 x 9mm	30000	148
S13380	600mm UltraSlot Treadsafe – 3m	F900	3000	600	1190		1129	300	70	2 x 9mm	30000	222

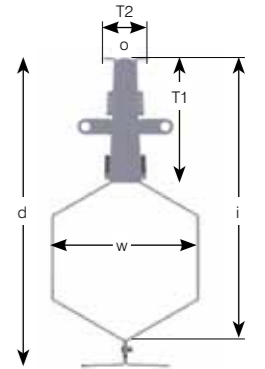

ULTRASLOT TREADSAFE 1m CHANNELS



Code	Description	Load Rating	Length (l) (mm)	Width (w) (mm)	Depth (d) (mm)		Invert (i) (mm)	Throat Depth (T1) (mm)	Throat Width (T2) (mm)	Slot Orifice (o) (mm)	Intake Area (mm ²)	Weight (kg)
S12160	150mm UltraSlot Treadsafe Shallow Invert – 1m	D400	1000	150	310		269	104	70	2 x 9mm	18000	12
S13155	150mm UltraSlot Treadsafe – 1m	F900	1000	150	404		364	200	70	2 x 9mm	18000	14
S13160	225mm UltraSlot Treadsafe – 1m	F900	1000	225	490		450	200	70	2 x 9mm	18000	18
S13165	300mm UltraSlot Treadsafe – 1m	F900	1000	300	697		634	300	70	2 x 9mm	18000	26
S13170	400mm UltraSlot Treadsafe – 1m	F900	1000	400	810		750	300	70	2 x 9mm	18000	49
S13175	500mm UltraSlot Treadsafe – 1m	F900	1000	500	926		866	300	70	2 x 9mm	18000	56
S13180	600mm UltraSlot Treadsafe – 1m	F900	1000	600	1190		1129	300	70	2 x 9mm	18000	80

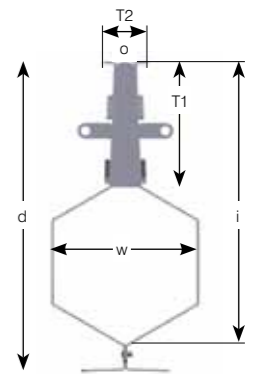

ULTRASLOT TREADSAFE 500m CHANNELS



Code	Description	Load Rating	Length (l) (mm)	Width (w) (mm)	Depth (d) (mm)		Invert (i) (mm)	Throat Depth (T1) (mm)	Throat Width (T2) (mm)	Slot Orifice (o) (mm)	Intake Area (mm ²)	Weight (kg)
S12560	150mm UltraSlot Treadsafe Shallow Invert – 500mm	D400	500	150	310		269	104	70	2 x 9mm	18000	6
S13555	150mm UltraSlot Treadsafe – 500mm	F900	500	150	404		364	200	70	2 x 9mm	18000	7
S13560	225mm UltraSlot Treadsafe – 500mm	F900	500	225	490		450	200	70	2 x 9mm	18000	9
S13565	300mm UltraSlot Treadsafe – 500mm	F900	500	300	697		634	300	70	2 x 9mm	18000	14
S13570	400mm UltraSlot Treadsafe – 500mm	F900	500	400	810		750	300	70	2 x 9mm	18000	27
S13575	500mm UltraSlot Treadsafe – 500mm	F900	500	500	926		866	300	70	2 x 9mm	18000	31
S13580	600mm UltraSlot Treadsafe – 500mm	F900	500	600	1190		1129	300	70	2 x 9mm	18000	43

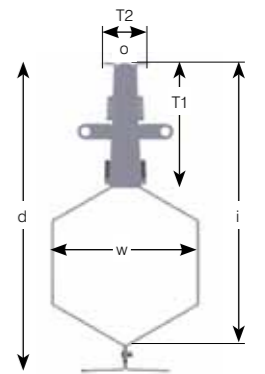

ULTRASLOT TREADSAFE DROP CONNECTORS



Type 1

Type 2

Code	Description	Type	From Channel		To Channel		Weight (kg)
			Width (mm)	Throat d (mm)	Width (mm)	Throat d (mm)	
S43400	150-225mm Drop Connector	1	150	200	225	200	1
S43405	225-300mm Drop Connector	2	225	200	300	300	5
S43406	225-300mm Drop Connector (Treadsafe)	2	225	200	300	300	5
S43410	300-400mm Drop Connector	1	300	300	400	300	3
S43415	400-500mm Drop Connector	1	400	300	500	300	4
S43420	500-600mm Drop Connector	1	500	300	600	300	7



Type 1

Type 2

GATIC UNIVERSAL END CAPS



Code	Description	To Suit Channel Width (mm)	Weight (kg)
S44100	100mm End Cap	100	0.3
S44105	150mm End Cap	150	0.4
S44115	225mm End Cap	225	0.8
S44125	300mm End Cap	300	1
S44135	400mm End Cap	400	3
S44145	500mm End Cap	500	5
S44150	600mm End Cap	600	11

GATIC UNIVERSAL END CAP INLETS/OUTLETS

Code	Description	To Suit Channel Width	Knockouts Dia. (mm)	Weight (kg)
S44200	100mm End Cap Outlet	100	92	0.3
S44205	150mm End Cap Outlet	150	115	0.4
S44215	225mm End Cap Outlet	225	115/165/205	0.8
S44225	300mm End Cap Outlet	300	115/165/205/255	1
S44235	400mm End Cap Outlet	400	115/165/205/255/320	3

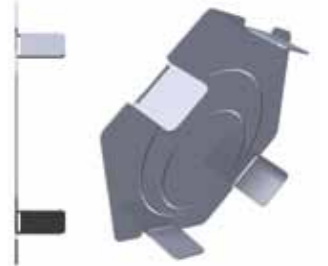

GATIC ACCESS BOXES



Code	Description	To Suit Channel up to	Load Rating	Height (mm)	Width (mm)	Depth (mm)	Intake Area (mm ²)	Box Weight (kg)	Cover/Grate Weight (kg)	Total Weight (kg)
S20300	Small Access Point c/w Paveslot Recessed Cover	225	D400	498	375	375	N/A	8	32	40
S20305	Small Access Point c/w Treadsafe Grating	225	D400	498	375	375	14013	8	43	51
S20310	Small Access Point c/w Recessed Cover	225	D400	498	375	375	N/A	8	40	48
S20315	Large Access Point c/w Double Triangular Grating	400	D400	802	576	576	35248	44	76	120

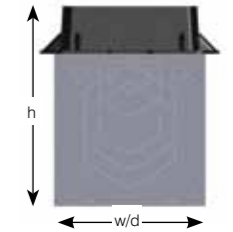

GATIC OUTLET BOXES



Code	Description	To Suit Channel up to	Load Rating	Height (mm)	Width (mm)	Depth (mm)	Intake Area (mm ²)	Box Weight (kg)	Cover/Grate Weight (kg)	Total Weight (kg)
S20200	Small Outlet Box c/w Paveslot Recessed Cover	225	D400	748	375	375	N/A	12	32	44
S20205	Small Outlet Box c/w Treadsafe Grating	225	D400	748	375	375	14013	12	43	56
S20210	Small Outlet Box c/w Recessed Cover	225	D400	748	375	375	N/A	12	40	52
S20215	Large Outlet Box c/w Double Triangular Grating	400	D400	1302	576	576	35248	71	76	147

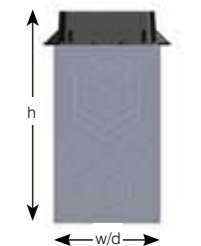

GATIC SILT BOXES



Code	Description	To Suit Channel up to	Load Rating	Height (mm)	Width (mm)	Depth (mm)	Intake Area (mm ²)	Box Weight (kg)	Cover/Grate Weight (kg)	Bucket (kg)	Total Weight (kg)
S20100	Small Silt Box c/w Paveslot Recessed Cover	225	D400	1048	375	375	N/A	18	32	4	54
S20105	Small Silt Box c/w Treadsafe Grating	225	D400	1048	375	375	14013	18	43	4	66
S20110	Small Silt Box c/w Recessed Cover	225	D400	1048	375	375	N/A	18	40	4	62
S20115	Large Silt Box c/w Double Triangular Grating	400	D400	1602	576	576	35248	90	76	18	183

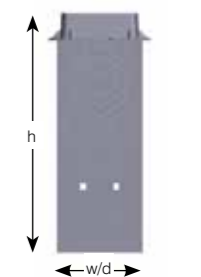

GATIC CATCHPIT CONNECTORS



Code	Description	Width (mm)	Invert	Length (mm)	Effective Length (mm)	Height (mm)	Weight (kg)
S40305	150mm Catchpit Connector	150	As Slotdrain	375	300	248	3
S40310	225mm Catchpit Connector	225	As Slotdrain	375	300	334	4
S40320	300mm Catchpit Connector	300	As Slotdrain	375	300	420	5
S40330	400mm Catchpit Connector	400	As Slotdrain	375	300	537	11
S40340	500mm Catchpit Connector	500	As Slotdrain	375	300	653	14
S40345	600mm Catchpit Connector	600	As Slotdrain	375	300	917	22

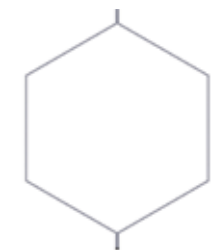

*Gatic Catchpit Connectors can be used with the PaveSlot, UniSlot, CastSlot, and UltraSlot ranges

*Gatic Access, Outlet and Silt boxes are suitable for channels up to 400mm wide.



GATIC COMBINED UHD ACCESS/OUTLET BOXES

Code	Description	Load Rating	Height (mm)	Width (mm)	Depth (mm)	Box Weight (kg)	Grate Weight (kg)	Total Weight (kg)
S30355	UHD Combined Access Box/Outlet Box up to 225mm	F900	532	887	546	39	91	130
S30360	UHD Combined Access Box/Outlet Box up to 400mm	F900	832	887	696	67	123	191
S30365	UHD Combined Access Box/Outlet Box up to 600mm	F900	1208	887	846	109	172	281

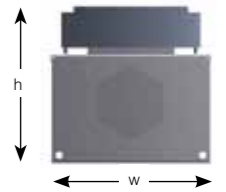

GATIC UHD OUTLET BOXES

Code	Description	Load Rating	Height (mm)	Width (mm)	Depth (mm)	Box Weight (kg)	Grate Weight (kg)	Total Weight (kg)
S33305	UHD Outlet Box up to 225mm	F900	1380	1487	750	143	91	235
S33310	UHD Outlet Box up to 400mm	F900	1680	1487	900	184	123	308
S33315	UHD Outlet Box up to 600mm	F900	2060	1487	1050	239	172	412

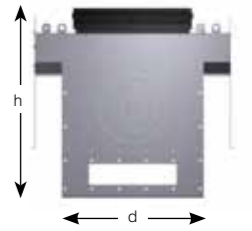

SLOTDRAIN CHANNEL PIPE

Code	Description	Load Rating	Length (mm)	Width (mm)	Depth/Invert	Weight (kg)
S14305	100mm Channel Pipe – 3m	As per Slotdrain	3000	100	As per Slotdrain	17
S14310	150mm Channel Pipe – 3m	As per Slotdrain	3000	150	As per Slotdrain	23
S14315	225mm Channel Pipe – 3m	As per Slotdrain	3000	225	As per Slotdrain	32
S14320	300mm Channel Pipe – 3m	As per Slotdrain	3000	300	As per Slotdrain	43
S14325	400mm Channel Pipe – 3m	As per Slotdrain	3000	400	As per Slotdrain	94
S14330	500mm Channel Pipe – 3m	As per Slotdrain	3000	500	As per Slotdrain	115
S14335	600mm Channel Pipe – 3m	As per Slotdrain	3000	600	As per Slotdrain	181

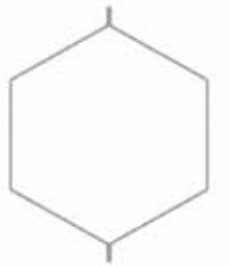



Slotdrain Intake Capacity

The intake capacity of each type of Gatic Slotdrain system is much greater than would be required in almost all realistic situations, despite the fact it only appears as a very neat 10 or 30mm wide slot in the pavement. The table right shows intake capacities for Gatic Slotdrain with surface water flowing to both sides, or from one side only (flow interception on a slope).

Tests undertaken by an independent hydraulics consultant indicated that the intake capacity of slot channel systems compares favourably with that of surface channel systems with conventional slotted gratings. Test results are available on request.

Rainfall Intensity

When designing a drainage scheme, professional engineers will most often choose a worst case rainfall intensity rate experienced over a period of 10 years or longer. This ensures that the system can accommodate the most severe storm event.

Width of Slot	Feed both sides	Intake capacity (l/s per linear metre)*		
		Feed one side only at cross slope		
		1:40	1:80	1:200
10mm	8.5	2.6	3.5	3.2
30mm Treadsafe	14	3.5	4.1	4.2
30mm Standard	14	5.0	5.5	5.5



Introduction

The design and requirements of a surface drainage system will vary according to geographic location.

Some regions may experience very low levels of rainfall throughout the year, so drainage systems can be designed to capture and conserve water, which may be viewed as a valuable commodity.

Other regions may experience long periods of adverse weather conditions, with high and prolonged rainfall rates. In these areas, drainage systems can be designed to quickly and efficiently dispose of surface water. However, the flow of water away from the channel system or site may have to be regulated in order to reduce the flood risk of rivers downstream of the site.

Gatic Slotdrain can be incorporated within the drainage scheme of urban projects to assist with the efficient collection and re-use of water. This provides construction industry professionals with a simple and effective method of water storage and flow regulation.

Water Storage

Gatic Slotdrain channels are available up to 600mm wide, the largest unit having a water storage capacity of 405 l/m.

By including larger Slotdrain channels in a surface drainage design, individual channel runs can be used to store higher volumes of water immediately after rainfall occurs. Stormwater may then be diverted to a larger water storage facility on site to conserve water. The flow of water away from the channel may be controlled to meet regulations regarding stormwater discharge from sites.

Gatic Slotdrain provides the greatest advantage when 'close to source' water storage is required. Examples are:

- A. Depth restrictions on site for pipe inverts, or no space to install a deep water attenuation tank.
- B. Water storage required at a shallow invert.
- C. Rocky ground so deep excavation is restricted.
- D. High water-table.
- E. Areas of site infill.

Gatic Slotdrain Channel	Capacity*
100mm	9 l/m
150mm	20 l/m
225mm	44 l/m
300mm	78 l/m
400mm	139 l/m
500mm	217 l/m
600mm	405 l/m

* Note: Total volume of channel units including throat.

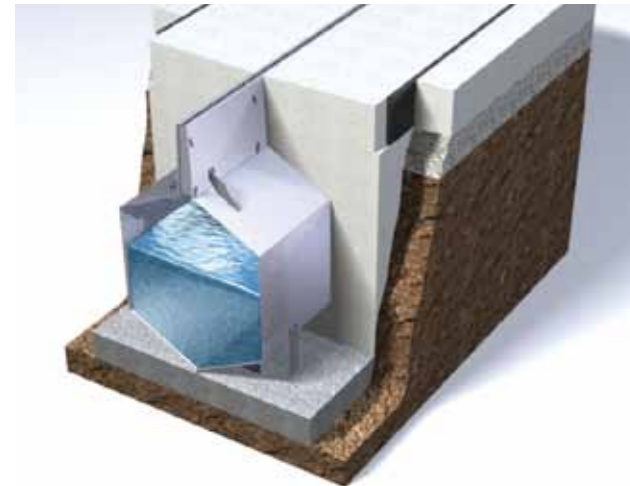

Flow Regulation

The easiest and most cost effective way to control water flow away from a slot drain channel system is through the use of an orifice plate, fitted to the catch pit of the channel system or to access units along the channel run. The methodology and hydraulic performance of the orifice plate is well proven and well understood. By designing the size of the orifice within a blanking end plate, maximum flow levels can be established and controlled.

If you are considering using Gatic Slotdrain for water storage, or if you wish to design a slot drain system where the flow will be regulated, please use the Hydraulic Design Software, or contact our technical department who can provide details of the size of orifice required to achieve the flow rates requested.

Flow Regulator

In order to control the flow of water away from the Gatic Slotdrain channel, a Flow Regulator accessory must be used.

Flow Regulators are supplied by Gatic in Grade 304 stainless steel, and are available in a variety of sizes to fit specific channel widths. There are two types of Flow Regulator available; used with the standard range of boxes and an alternative design used for catch pits formed from concrete on site.

Flow Regulator – Performance & Maintenance

The Flow Regulator accessory supplied by Gatic incorporates a semi-circular sharp edged orifice, which is located at the invert level of the nearest slot drain channel, to ensure that there are no restrictions to flow in normal operational conditions.

If the orifice becomes blocked with debris, the Flow Regulator also incorporates an overflow weir at the top of the unit. This ensures that the channel system will not become totally blocked, which could cause surface flooding.

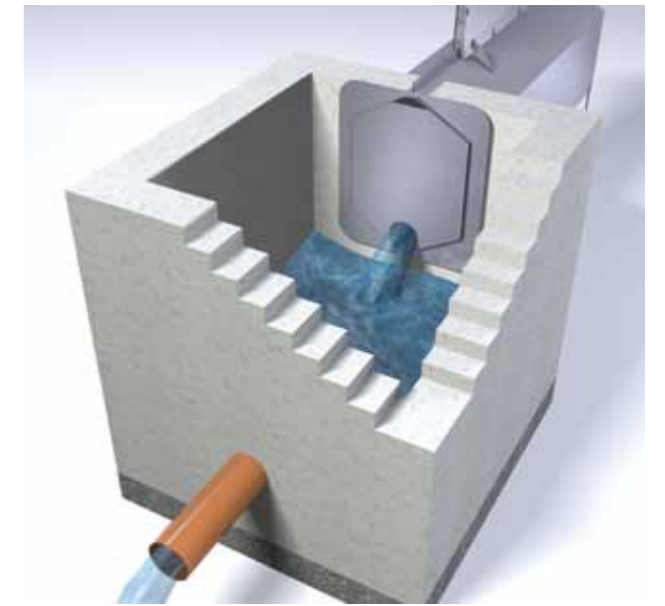

A Flow Regulator can be installed at any point along the channel run where there is an access unit or catch pit, thus water flow can be regulated at any point along the channel run. This is particularly useful on sloping sites, where water can be retained at all levels of the site, rather than just at the bottom of the channel run.

The Flow Regulator is in all cases bolted neatly onto the inside wall of the catch pit or concrete chamber. This allows easy inspection and removal, for cleaning and maintenance purposes.



FLOW REGULATORS

(for use with Modular Boxes)

Code	Description	Height (l)	Width (w)	Invert	Weight (kg)
S40500	225mm Flow Regulator	321	342	As Slotdrain	6
S40505	300mm Flow Regulator	395	427	As Slotdrain	8
S40510	400mm Flow Regulator	496	545	As Slotdrain	14

*Outlet size to order on all Flow Regulators

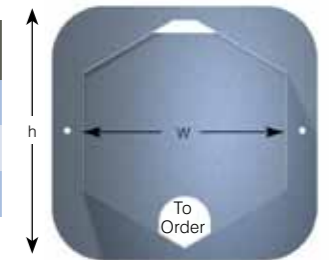

FLOW REGULATORS

(for use with Chambers formed on site)

Code	Description	Height (l)	Width (w)	Depth (d)	Weight (kg)
S40515	225mm Flow Regulator	332	368	As Slotdrain	7
S40520	300mm Flow Regulator	406	454	As Slotdrain	10
S40525	400mm Flow Regulator	506	569	As Slotdrain	14
S42030	500mm Flow Regulator	606	685	As Slotdrain	19
S42035	600mm Flow Regulator	706	950	As Slotdrain	29

*Outlet size to order on all Flow Regulators

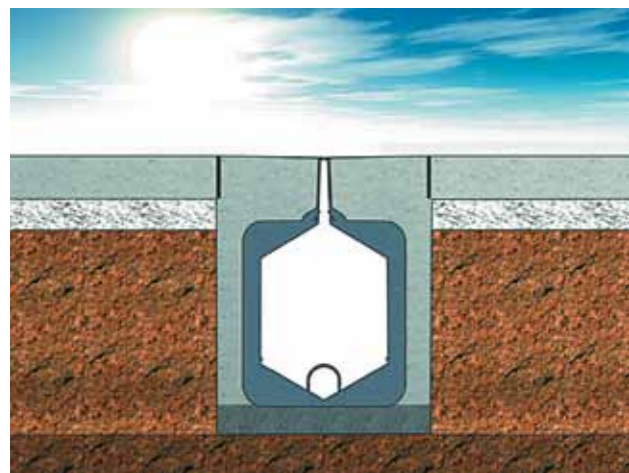
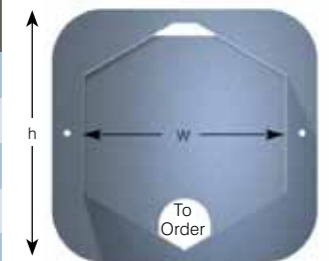

Dry weather conditions.

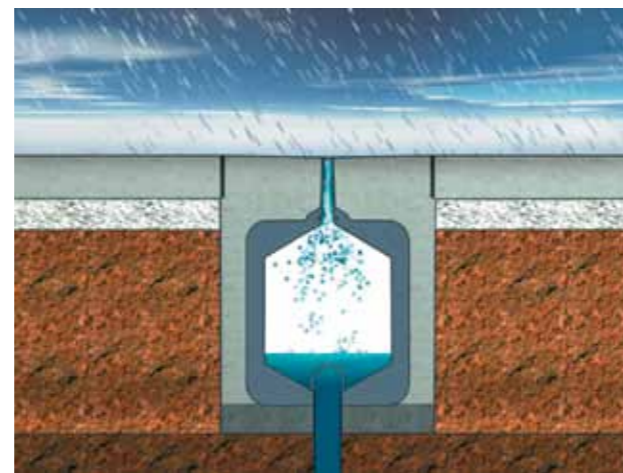

Rainfall starts, the Slotdrain begins to fill with water and discharges via the flow regulator.

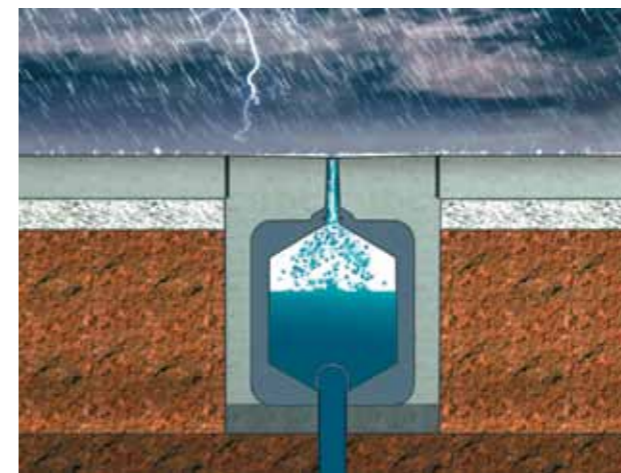

Water level in the Slotdrain system rises with storm intensity. Outflow reaches designed regulated flow rate without flooding surrounding area.

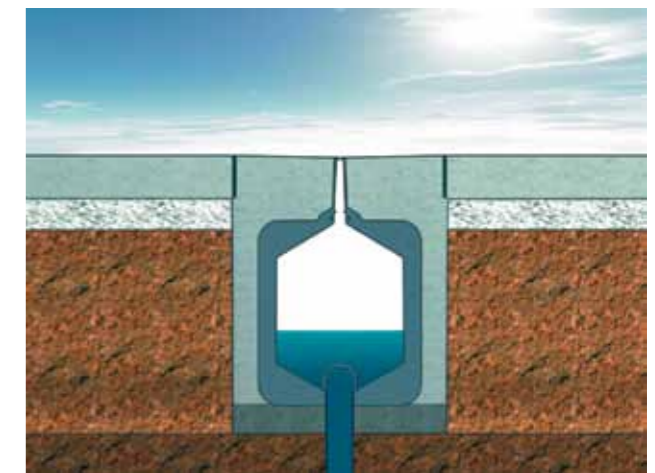

Storm ceases, controlled outflow continues and water level in the Slotdrain system falls.

Design Formulae

The common equation used by professional engineers for the design of surface channel drainage is Manning's formula for flow calculation. This relates to the steady, uniform flow found in open channels such as culverts or irrigation trenches. This formula does not allow for the effects of lateral intake of water along the full length of a grated trench drain or slot drain system.

HR Wallingford

The established and universally accepted methodology for calculating the hydraulic performance of linear drainage systems is the formula derived from the research carried out by HR Wallingford in the Report SR581 'Hydraulic Capacity of Drainage Channels With Lateral Inflows'.

As the name suggests, the formula derived from this research takes into account the flow of liquid carried through the slot channel, as well as the lateral intake of liquid through the slot along the full length of the channel. The liquid entering the slot along the length of the channel will have a disrupting effect on the flow of water through the channel, which leads to nonuniform flow within the channel.

Gatic Slotdrain 'Hydraulic Design Software' successfully incorporates the formula determined by HR Wallingford, so achieves very accurate results regarding the sizing of slot drain channels. These have been confirmed by manual calculations undertaken by professional engineers on many projects where Gatic Slotdrain has been installed.

For further information regarding the formulae used in the design software, please refer to the 'Help' section within the software.

Alternative Formulae

There are other formulae that have been used by some surface drainage manufacturers to size and design channel schemes. One such is the Saint-Venant methodology and equation. When required, our technical department can provide an alternative design using this methodology, in order to provide a comparison with competing systems where their design has been based on this formula.

The Hydraulic Design Software provided by Gatic also has the option to calculate channel sizes using this methodology at the press of a button in order to avoid the necessity of manual calculations.

Gatic Slotdrain Channel Sizing – Manual Procedure

Gatic Slotdrain is proven over hundreds of projects in the UK and overseas, however some professional engineers may wish to understand the formulae used within the software and calculate the channel hydraulics manually. Below are the manual procedures for sizing Gatic Slotdrain channels for a given project.

Procedure for the design of Gatic Slotdrain

1. Calculate the total area of the catchment drainage area for a specific channel; in square metres.
2. Apply a permeability factor to that area to achieve an impermeable area (A_p) in square metres. Suitable figures for area multipliers are shown in the table below:

Material	Run-off coefficient
Concrete	1.0
Roofing Materials	0.95
Tarmac	0.90
Asphalt	0.85
Block/Stone paving – cement joints	0.80
Block/Stone paving – open joints	0.60
High permeability materials (gravel etc)	<0.60

3. Decide upon a design rainfall rate (r) in l/s/m.
4. Calculate required flow from the impermeable area x rainfall rate (A_p.r) in l/s.
5. If the slotdrain is to be used for conveyance of flow from other sources, such as roof drainage down-pipes, then add the sum of the point inflows to the required flow.
6. Determine the required length of channel (L) in m.
7. Determine the ground slope along the length of the channel (S) as a %. The maximum value for S should not exceed 3.3% and S should not be adverse to the direction of flow along the channel.
8. Decide upon the design loading for the channel. If F900kN loading is used, decide upon the slot type (Standard or Treadsafe). Select a channel range that is to be used for the design.
9. Decide if a stepped channel design can be incorporated; if so, proceed to Step 16 in the list.

Single Size Channel.

10. Calculate the slope factor b using the following rules:
 - for $S \leq 0.5\%$ $b = 0.132S - 0.00022$
 - for $0.5\% < S \leq 3.33\%$ $b = 0.00044$
11. Select a suitable channel from the range. When full, the water in the channel will be just below the section. Determine the maximum depth (h) in m, and the channel cross sectional area (A) in m² for the chosen channel.
12. If L/h exceeds 1000 then select a larger channel and repeat from Step 11, or reduce the channel length and repeat from Step 6.
13. Calculate the channel capacity from:

$$Q = 2.66 A^{1.25} \left(6.74 \times S^{0.7} \frac{L}{h} 0.4 + b \right)$$

14. If the required flow; calculated at step 5, is larger than the channel capacity calculated at Step 13, then select a larger channel and repeat from Step 11.
15. If the required flow; calculated at Step 5, is smaller than 40% of the channel capacity calculated at Step 13, it may be possible to use a smaller channel. To check this, select a smaller channel size and repeat from Step 11.

Stepped Fall Channel Design

16. First time through, use the smallest channel in the range and perform the calculations as the previous Steps 10-13.
17. If the required flow; calculated at Step 5, is less than the channel capacity calculated at Step 16, then proceed to Step 20, otherwise select the next size of channel in the range.
18. Calculate the imposed slope given by the sum of the drops (steps) in the invert, divided by the channel length ($\sum \text{step} * 100 / L$) as a %.
19. Add the channel slope calculated at Step 7 to the imposed slope calculated at Step 18, to give S, and repeat the calculations from Step 16.
20. Calculate the required flow from the impermeable area x rainfall rate:
21. First time through, use a 3m length of channel (L_x = 3m) or any other length that the designer considers may be close to the finished design length.

22. Calculate the flow in the channel, from L_x times the flow per unit length, calculated at Step 20. Add any point inflows that occur in channel length L_x from the upstream end, to achieve the design flow.

23. Using the slope calculated at Step 19; and hence the last calculated value of b, and the values of A and h for the size of channel being considered, calculate the flow in the channel using:

$$Q = 2.66 A^{1.25} \left(6.74 \times S^{0.7} \frac{L_x}{h} 0.4 + b \right)$$

24. If the required flow, calculated at Step 22, is less than the channel capacity, calculated at Step 23, then increase L_x by 3m (or any other length that the designer considers may be close to the finished design length) and repeat from Step 22.
25. Determine the length of channel at the current size, by subtracting the previous length of channel from L_x.
26. Use the next size unit in the design until all sizes set at step 17 have been allocated. Increase L_x by 3m (or any other length that the designer considers may be close to the finished design length) and repeat from Step 22.

Key:

- AP impermeable area.
- r rainfall rate {l/s/m}.
- L length of channel run.
- S ground slope along length of channel
- b coefficient.
- h depth from invert to bottom of slotdrain throat (channel body).
- A cross-sectional area of channel body (excluding throat).
- Q flow capacity of channel.
- L_x part length



Slotdrain Design Software

We produce software that allows you to design your own Slotdrain system using the same programme as our in-house design engineers. To be sent a CD containing this free software, simply register your details with us. You can do this on the MyGatic section of our website, or by emailing/ phoning us using the contact information at the back of this brochure.



Regulation 6(4) of The Dangerous Substances and Explosive Atmospheres Regulations (2002) states '...it is the duty of the site operator to put in place measures to collect and safely retain any spillages of dangerous substances'.

Gatic Slotdrain has been empirically tested at an operational filling-station forecourt by a leading Fire Service petroleum officer. The results demonstrated that Gatic UltraSlot with the 30mm throat orifice (standard or treadsafe) is eminently suitable for use in all forecourt and fuelling areas, as it provides a continuous interception slot that prevents wash-over of surface liquids. Whilst the test demonstrated that a single channel coped with almost all of the spillage, a strong recommendation was given to incorporate a twin, parallel run of drainage channels to ensure full compliance with the above regulation even in the event of a partial blockage or build up of silt in the channels.

Copies of the full Fire Service Test Report are available upon request.

Roughness

Gatic Slotdrain is manufactured from 3m lengths of galvanised steel, which leads to lower frictional losses from both the surface and joints, giving improved flow performance over some rougher concrete based products, or products supplied in shorter lengths requiring a greater number of joints.

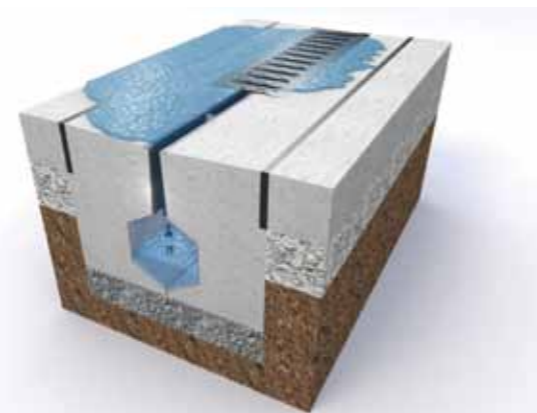

Self-Cleansing Properties of Gatic Slotdrain

The hexagonal profile of Gatic Slotdrain ensures that self-cleansing is improved even with the smallest amount of rainfall. The v-shaped channel invert ensures that at low flows, the water is channelled into a narrower cross section, increasing the flow depth and thus the effective hydraulic gradient. Additionally, the flow is always running in the same well defined course, reducing the likelihood of silt build up.

Watertightness

Gatic Slotdrain has been independently tested and certified by BSI to comply with the watertightness requirements of BS EN 1433:2002 – Drainage Channels for Vehicular and Pedestrian Areas.

Stepped Fall Channel Layout

Gatic Slotdrain channels are available in various sizes ranging from a small and compact 100mm wide channel through to an extremely high capacity 600mm wide channel. Whilst single size channel runs may at times prove to be more suitable, there are significant improvements in hydraulic performance, invert depths and total installed cost where Slotdrain designs incorporate step falls.

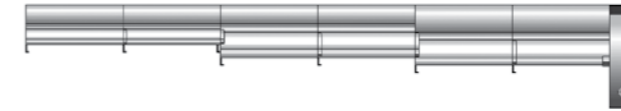

Benefits

- Creates an installed gradient within the channel, achieving a positive flow towards the outlet even if there is a 0% longitudinal ground slope along which the channel is laid. Often the installed gradient is greater than 0.6%.
- Large surface areas can be drained with a single Slotdrain run, which reduces the number of Slotdrain runs required in a given area.
- Longer runs can be formed by interconnecting channel sizes, greatly reducing the requirement for underground pipe-work, manhole chambers and outlets and significantly reducing installation time and costs.
- Achieves higher water flow velocity within the channel to improve the self-cleansing capabilities of the system.
- Increased flow velocity reduces the channel sizes required in the channel run.
- Optimises the use of smaller channel units at the head of the channel, therefore reducing installation costs.
- Minimises invert depths at the outlet end.
- Reduces the amount of excavation, by using the smallest channels available.



Same Depth Channel Layout

Channel runs formed from same depth channel units may prove more practical and easier to install in some projects. These are generally used when the channel is laid along a positive gradient. Same depth channel layouts can also be used when there is no ground slope, usually if the channel run is short. In such instances, water will find its way to the outlet point, due to the effect of gravity on the body of water, which achieves a natural installed gradient regarding the water line within the channel.

When using Slotdrain as a storage medium, a same depth channel layout also provides storage volume for surface water.

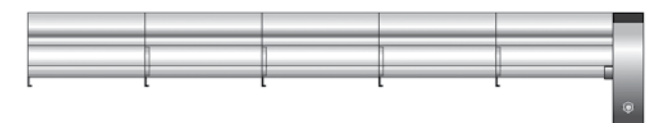

Drop Connectors

These system components provide a smooth transition between different sizes of channel, whilst the surface detail of the channel run remains the same.

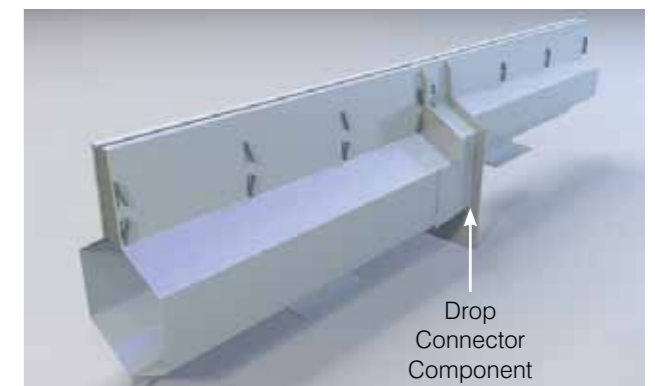

Drawings are available in both 'AutoCAD' or 'pdf' formats. Drawings are included in the Hydraulic Design Software package, can be downloaded from the website (www.gatic.com), or can be supplied on a Product CD. Please contact Gatic or complete an enquiry form on the website.

Manufactured from high quality galvanised sheet steel, and with an innovative design incorporating special features to enhance the structural integrity of the installation, the Gatic Slotdrain system is strong and durable. When specified and installed according to manufacturers' recommendations, the system is fit for purpose and will meet the performance requirements of the client and specifying engineer.

Load Testing

Gatic Slotdrain channels comply with BS EN 1433:2002, Load classes A15 to F900.

Installation Details

A comprehensive set of standard construction installation details are available for each channel type and size, relating to a variety of surface materials (flexible asphalt, paving units, concrete pavement). Installation details and product drawings are also available for the system accessories (modular boxes, drop connector, end caps, flow regulators, etc) supplied with Gatic Slotdrain.

Durability

Impact Resistant

Gatic Slotdrain is manufactured from pre-galvanised sheet steel. Channel units are impact resistant, and will not break during transport, site storage, installation and when the facility is in operation. This reduces replacement costs for the contractor, and lowers long term maintenance costs for the client.



Extreme Temperatures

The system can be used in regions where temperatures may fall well below freezing point. Gatic can supply a much deeper modular outlet to special order (for D400 and F900 load applications), for regions subject to perma-frost, to ensure that underground pipes running from these boxes are located beneath the perma-frost layer.



Longevity

Specified and installed in accordance with manufacturers' recommendations, Gatic Slotdrain should perform and be 'fit for purpose' for the lifetime of an appropriate site.



Gatic Slotdrain can be considered as a concrete trench drainage system, with a durable steel lining along the inner wall of the channel. The system is therefore likely to be more durable compared with a 'cast in place' trench drainage system formed from concrete on site.

For performance information regarding more extreme environmental conditions and/or resistance to specific chemicals, please refer to Gatic.

Gatic Slotdrain can also be supplied in stainless steel.

To meet the strength requirements of BS EN 1433:2002, the following has been concluded:

A15 – D400 Loading:

All channel sizes – Steel reinforcing is **not required** within the channel concrete encasement/surround.

E600 – F900 Loading:

*UltraSlot channel sizes 150-400mm wide – Steel reinforcing is **not required** within the channel concrete encasement/surround.

UltraSlot channel sizes 500 and 600mm wide – Steel reinforcing **is required** within the channel concrete encasement/surround.

A major time and cost saving for the client and contractor can be achieved, since UltraSlot channels 150-400mm **do not require** steel reinforcing when used in F900 loading environments. However, the project engineer may decide to install steel reinforcing around all sizes of Gatic Slotdrain where the traffic is heavy and constant, or where ground conditions dictate.

Installing Steel Reinforcing

Steel reinforcement installation details are available from Gatic on request for all UltraSlot channels and for chambers formed from concrete on site. These drawings can be supplied to provide an indication of the steel reinforcing for an F900 loading application.

Each project has a unique and diverse combination of ground conditions and traffic movements that are beyond the control of Gatic. As such the Slotdrain product may be required to withstand vertical and horizontal loads outside the scope of the load class and testing criteria specified within BS EN 1433:2002. We therefore advise that the specifying engineer departs from our standard installation details and adds reinforcement or other applicable construction details where necessary.



Steel reinforcing bars can be threaded through the concrete anchor points located either side of the UltraSlot channel throat, providing a positive connection point for the steel reinforcing cage.

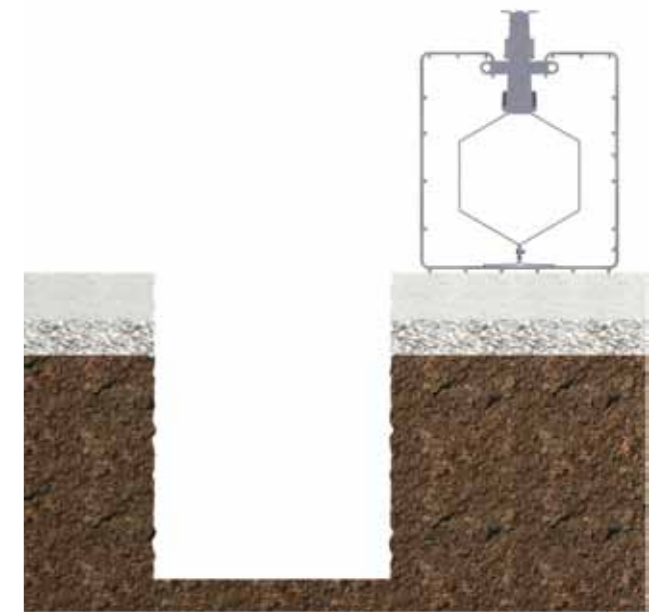

Fitting of the steel reinforcement cage can be carried out away from the trench, making the task easier for the contractor. The completed unit can then be lifted into the trench.



Gatic Slotdrain modular drainage system as manufactured by Gatic

www.gatic.com

The channel system should have a continuous, single, horizontal slot design to ensure maximum intake and to resist 'wash-over' of surface liquids.

Channels to be a single unit design, with no removable parts. Units should have a hexagonal profile with v-shaped channel base for improved self-cleansing and optimum flow. Channels to have a *10mm/ 30mm (*insert appropriate dimension – *8mm/10mm/28mm/30mm) wide intake slot and a tapered throat. Throat walls can be designed to incorporate weep holes to allow for drainage of sub-surface water if this is required.

Channels should be impact-resistant and manufactured from galvanised sheet steel to BS EN 10346:2009 DX51D+Z275-NA-C. Channel material should have 0% water absorption. All materials used in manufacture of channel units should be heat-resistant and recyclable. The manufacturer should ideally operate in accordance with the European Environmental Standard BS EN ISO 14001:2004. Channel units should be level invert and supplied in 3.0m, 1.0m or 0.5m lengths. A stepped fall channel configuration can be achieved if required by using varying depths of Gatic Slotdrain channel in combination, towards the outlet.

Channels should be fitted with socket and spigot joints, support feet and concrete anchors that are integral within the design of each unit. Anti-lift channel stabilisers will be fitted to Gatic Slotdrain channels that are 300mm, 400mm, 500mm and 600mm wide. Channels are to be fitted with a removable plastic throat protection strip or tape to prevent debris from entering the slot and throat area during installation. The system shall be supplied with appropriate 'End Caps' and 'Drop Connectors' relevant to the channels specified. Please refer to the manufacturer's product literature for reference numbers of relevant End Caps/ Drop Connectors to be specified and installed. All components within the scope of this system shall be obtained from the manufacturer.

The system shall be installed in accordance with the manufacturer's guidelines and the work carried out as specified by the structural/mechanical engineer and in accordance with recognised good practice. Standards of workmanship should generally be as specified in BS EN 752:2008 and BS 8000-11:2011: Part 14:1989.

Outlets – D400 Channel

The system is to be supplied with a range of Access, Silt and Outlet Boxes designed to withstand a load of D400, complete with recessed covers or gratings as supplied by Gatic.

Outlets – F900 Channel

Ultra Heavy Duty Outlet Boxes will be used to terminate all Gatic UltraSlot runs. Alternatively, purpose made 'Catch Pit Connectors' are available from Gatic to provide simple connection of channel units to Catch Pits/Manhole Chambers. Gatic also provides a range of Ultra Heavy Duty (F900) grated or solid covers for Catch Pits/Manhole Chambers.

The system shall be supplied with in line Access Units where required. These should be fitted with solid or grated covers up to F900 loading, as available from Gatic.

Specific Channel Types

The channel type(s) should be the following: List product reference and characteristics for each channel type to be specified – please refer to product catalogue for relevant details.

Gatic Slotdrain Ref: (*Insert Channel Reference)
Where Gatic UltraSlot is specified, if the 'Treadsafe' option is required, the relevant product reference number should be selected.

Channel Width: mm
Channel Invert Depth: mm
Channel Overall Depth: mm
Throat Depth: mm

NB: Where possible, please attach data sheets from the Slotdrain software programme for each channel run.

These contain all of the specific information referred to above.

Gatic Website

The Gatic website has been refurbished and now contains even more technical information and guidance than before.

We have increased our online resources and improved the website design, to ensure that you can now find all the technical information you need to correctly design and specify the right Gatic system for your project.

Divided clearly into three categories to reflect our product families, you can now navigate areas that are dedicated to either **Access Covers, Slotdrain** or **StreetWise** furniture.

Within each product range, you can explore features and benefits, technical details, graphics, diagrams, and case studies. If you set up a MyGatic account on the website (registering your name and email address), you will be able to store all the literature, technical specifications and images that you have collected while browsing through the site, and access them again from your MyGatic page in the future simply by logging in.

Our popular Access Covers tutorial can be used for free on the site as before, and we have now also made available our Design and Engineering software for Slotdrain. This programme takes you through the complete process of designing a Slotdrain system that will meet the requirements of your project, and is the same software that is used by our own engineers.

Visit us on our website: www.gatic.com



Slotdrain Design Software

Our design software allows you to design your own Slotdrain system using the same programme as our in-house design engineers. To be sent a CD containing this free software, simply register your details with us. You can do this on the MyGatic section of our website, or by emailing/phoning us using the contact information at the back of this brochure.

Slotdrain Handling, Installation and Maintenance Guide

We produce illustrated literature giving advice and general information on safe handling, installation and maintenance of Slotdrain products. You can download this brochure directly from our website, or alternatively, email/phone us to request a copy.



Gatic are pleased to offer CPD presentations at your premises covering all aspects of surface water drainage and attenuation.

Our presentations are accredited by the CPD Certification Service and count towards the continuing personal and professional development of attendees. This can be a factor worth bearing in mind for those individuals seeking professional membership.

Links are available at www.gatic.com to details of all Gatic products on the NBS Plus Product Register.

NBS Plus is a library of manufacturers' product information linked to specific clauses within the NBS specification software products, NBS Building, NBS Landscape, NBS Engineering Services and NBS Scheduler.

It enables manufacturers to make their product information available to specifiers at the point they need it most – when completing a specification.

The links within the specification software allow fast and accurate downloading of appropriate product information, directly into a specification, at the click of a button.



FacadeSlot Channel



FacadeSlot with End Cap



FacadeSlot with Outlet Box



FacadeSlot with PaveSlot Channel connected



FacadeSlot with Access Unit
(Recessed Cover)



FacadeSlot with Outlet Box in corner



FacadeSlot with End Cap Outlet Box
(End of run. Grate, frame and pipe supplied by others)

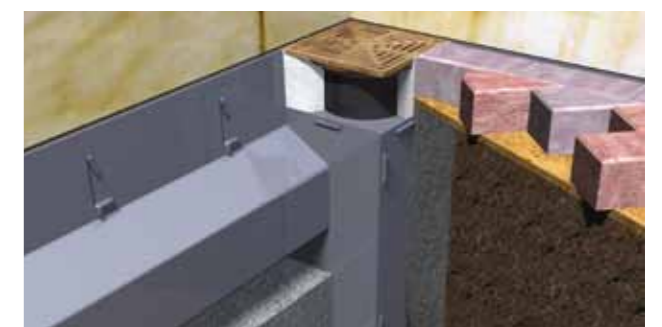

FacadeSlot with End Cap Outlet Box
(Corner. Grate, frame and pipe supplied by others)

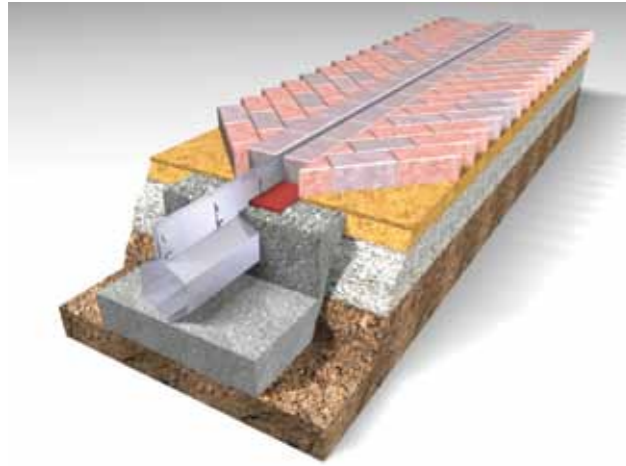

PaveSlot Channel installed in paving

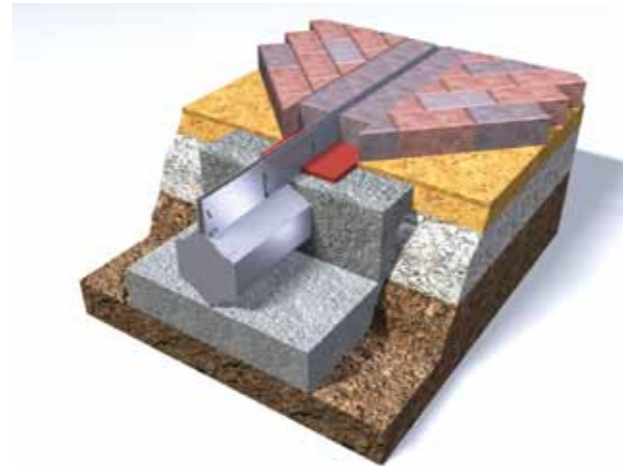

PaveSlot with End-Cap

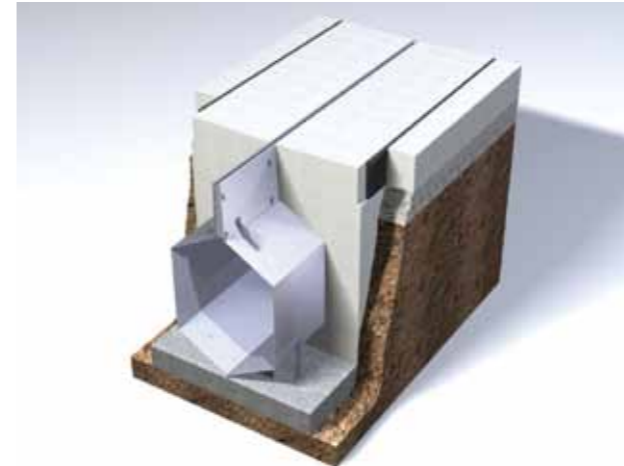

UniSlot Channel installed in Concrete

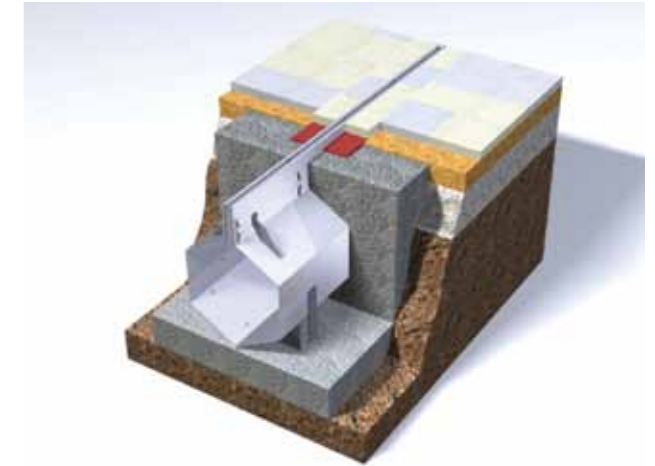

UniSlot Channel installed in Paving

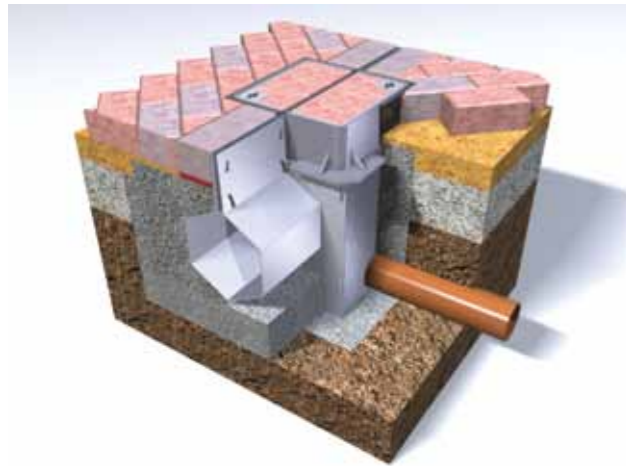

PaveSlot Channel with Outlet Box
(Recessed Cover)

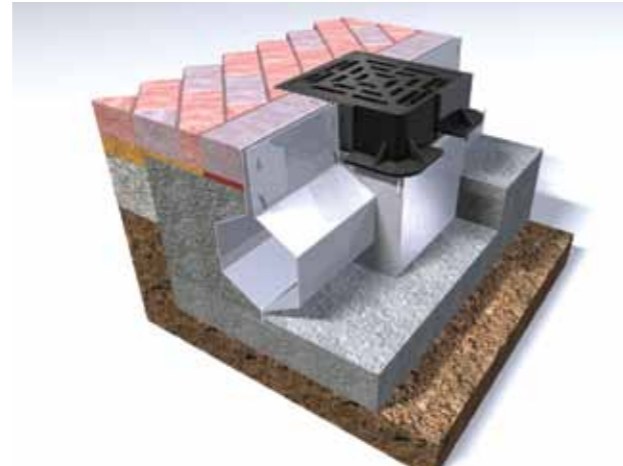

PaveSlot with Access Box
(Grating)

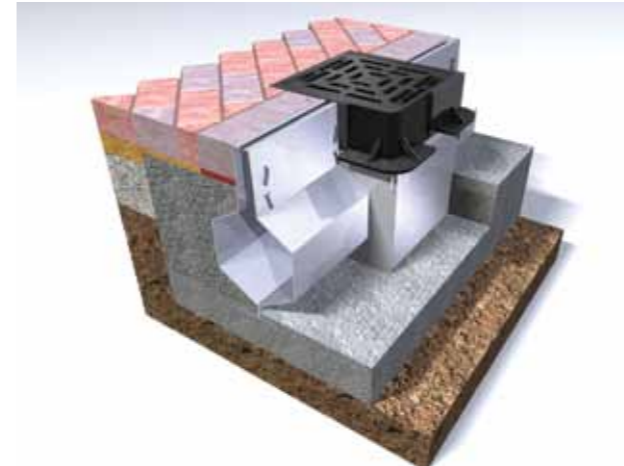

UniSlot with Access Box
(Grating)



UniSlot with Silt Box
(Pipe supplied by others)

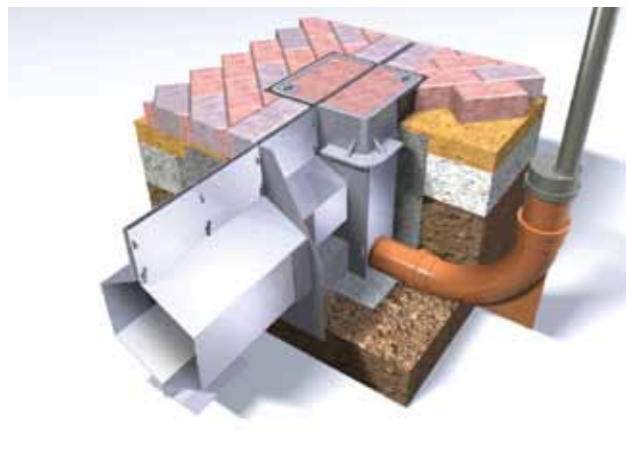

PaveSlot with Type 1 Drop Connector and Outlet Box
(A building down pipe is fitted for rainwater harvesting)

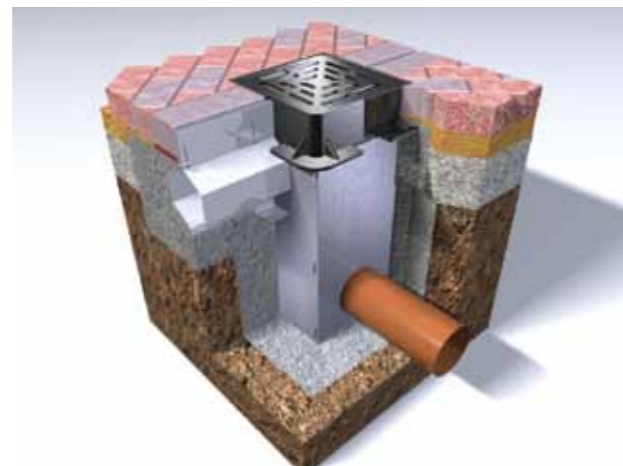

PaveSlot with Outlet Box
(Grating)

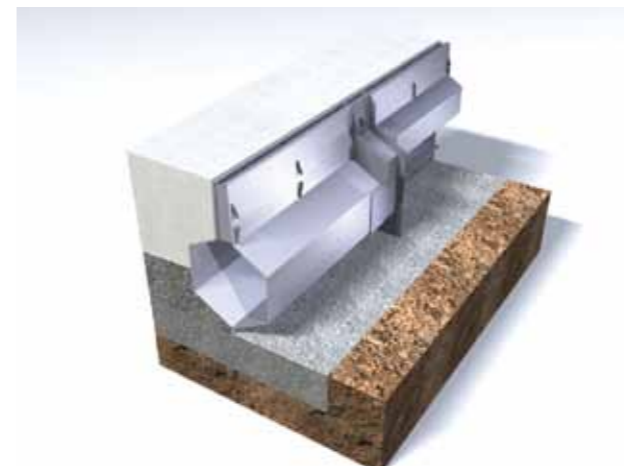

UniSlot Type 2 Drop Connector

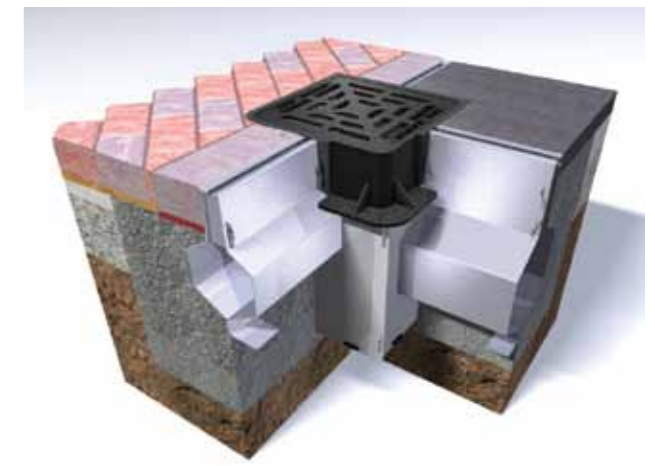

UniSlot with Access Box (Corner)
(Grating)

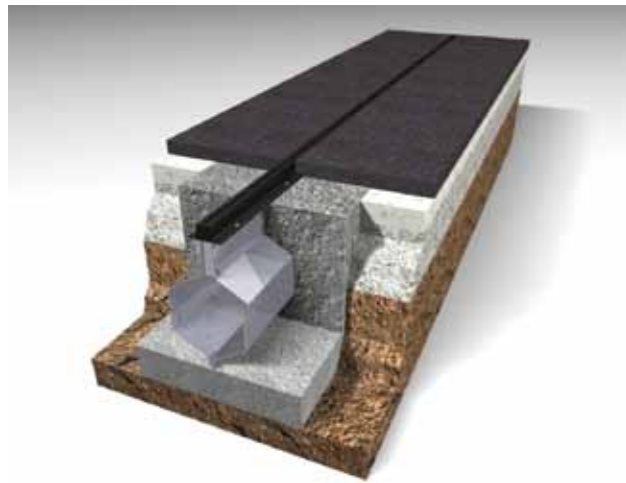

CastSlot 8 Channel in Asphalt

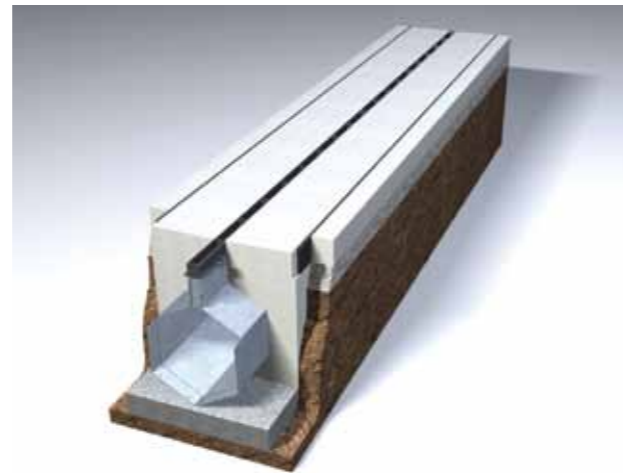

CastSlot 28 Channel in Concrete

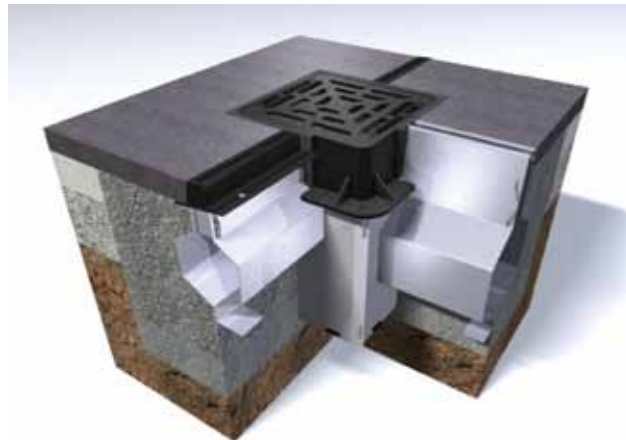

CastSlot with Connection to Access Box & UniSlot (Grating)



CastSlot with Outlet Box (Grating)

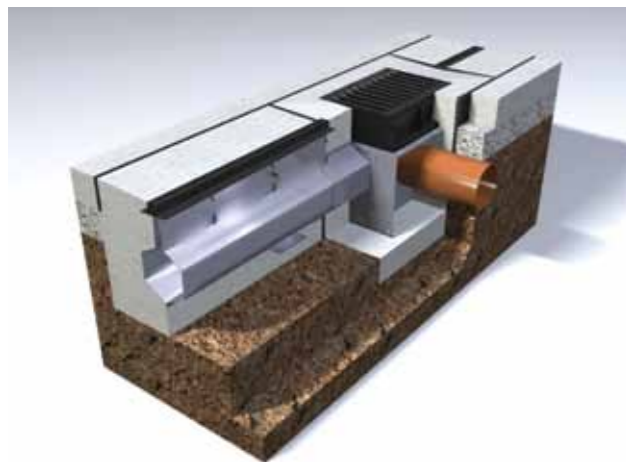

CastSlot with UHD Combined Access/Outlet Box

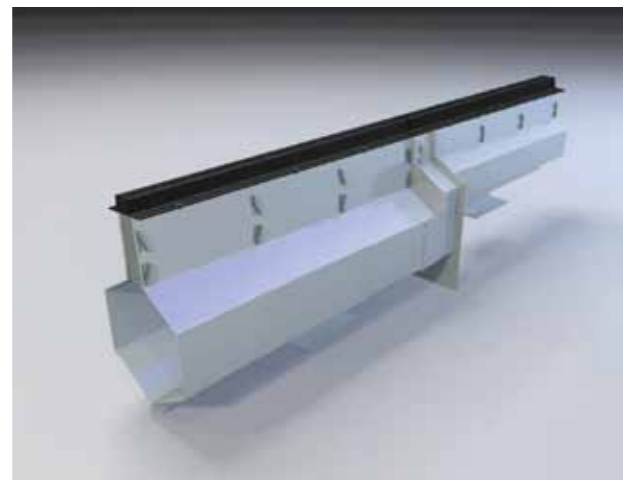

CastSlot with Type 2 Drop Connector

Treadsafe Channel
Gatic UltraSlot F900 with Treadsafe Bar; the slot opening can be reduced by using a Treadsafe bar, making the channel run safe to cross, for passengers and airport personnel.



UltraSlot Channel in Concrete Surface (Mixed medium)

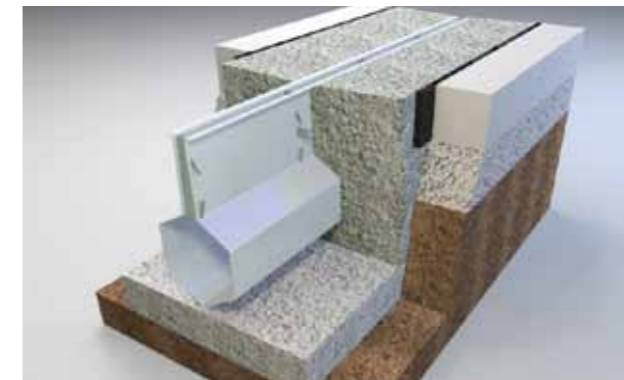

UltraSlot Channel in Concrete Surface



UltraSlot with UHD Access Box

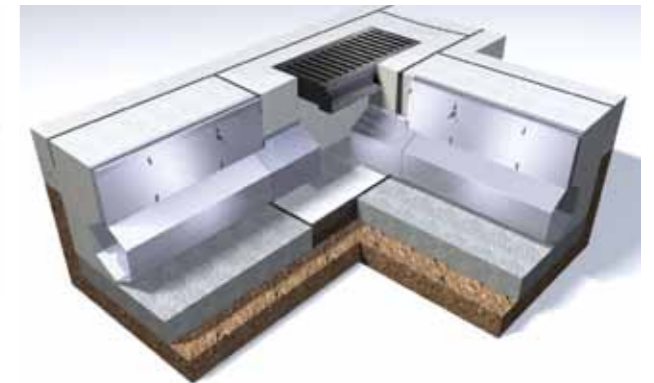

UltraSlot with Corner Catch Pit

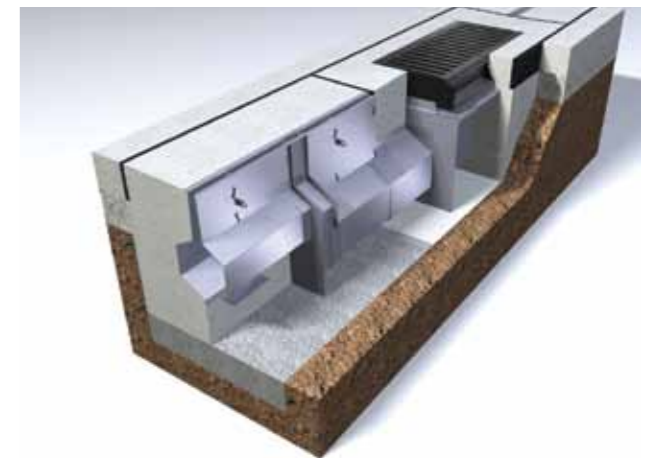

UltraSlot with Type 2 Drop Connector

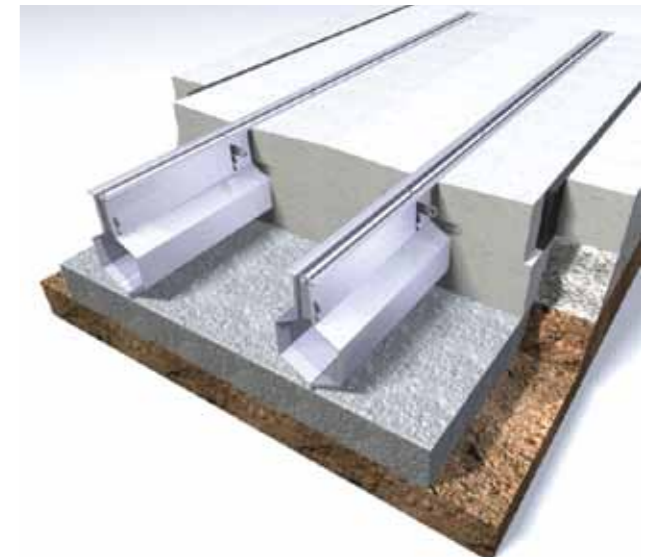

Parallel Channel Run
UltraSlot channels in parallel installation; used to intercept high volumes of water, or separate fresh rainwater from contaminated surface water (airports).

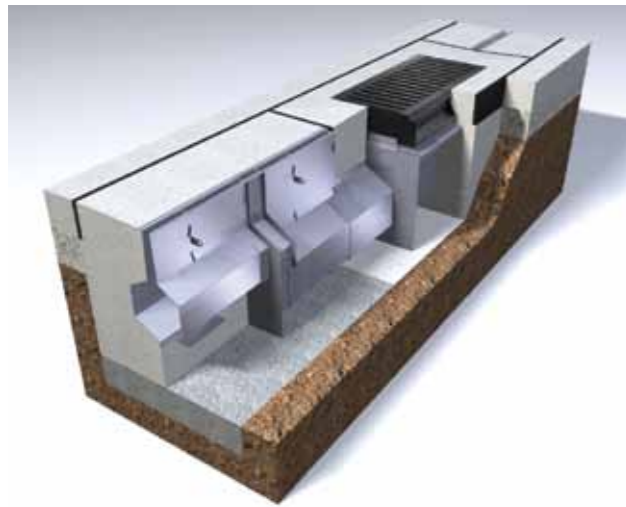

UltraSlot UHD Access Box, Type 2 Drop Connector & Catch Pit Connector.

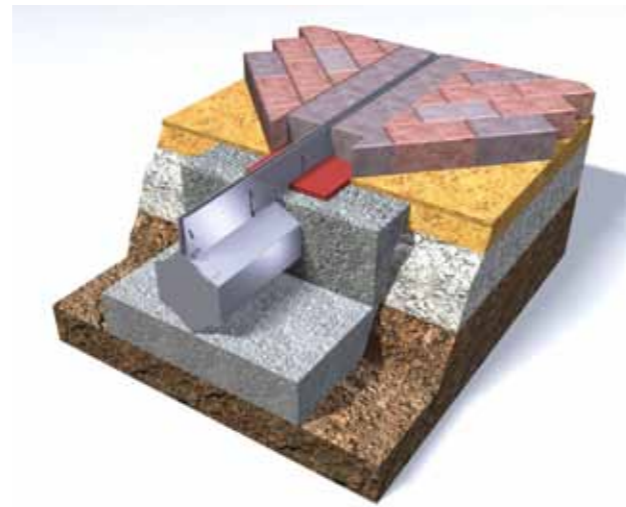

Universal End Cap

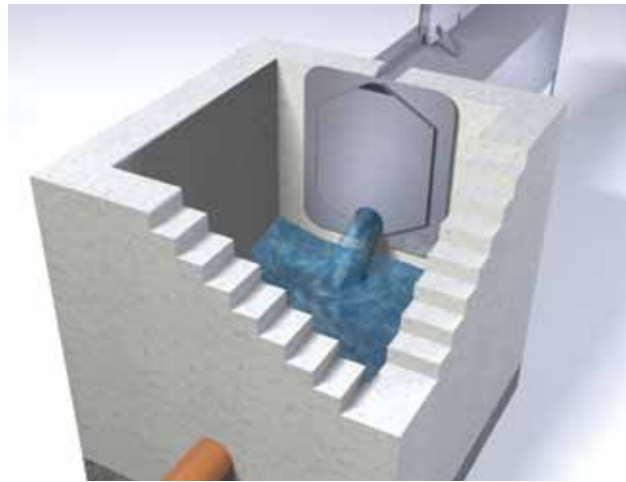

Flow Regulator Fitted into Constructed Catch Pit



Flow Regulator Fitted into Large Modular Outlet Box

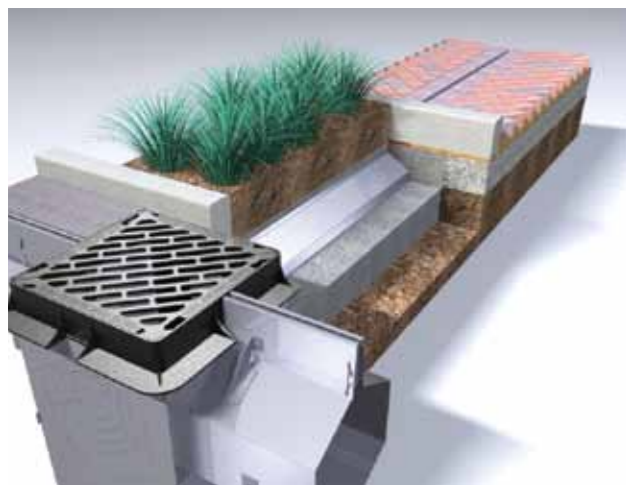

Large Access Box with Double Triangular Grating Connected with Universal Channel Pipe



Large Access Box with Double Triangular Grating

Expansion – Steel & Concrete

There are a number of considerations to take into account regarding expansion and the installation of Gatic Slotdrain.

Coefficient of Expansion

The coefficient of thermal expansion for a material is a measure of how much that material will expand for each change in temperature of 1 degree. A table of commonly used materials and their expansion coefficients is set out below:

Material	Expansion (10 ⁻⁶ mm/K)
Steel	13
Concrete	14.5
Polypropylene	100-200
Polyethylene	35-60
Polyester	123

*Steel has a similar expansion rate to concrete, so Gatic Slotdrain will expand and contract at a similar rate to the channel concrete encasement/surround, thereby minimizing stresses caused by differential rates of expansion.

Installation – Expansion Joints

Please refer to the standard construction installation drawings provided by Gatic for details regarding the position of expansion joints.

'Longitudinal' and 'Crack Control Joints' (Crack Inducers/ Shrinkage Joints) are not normally required for installations where asphalt or paving units (with sand filled joints) are the surface finish. This is because these surfaces are 'flexible' and will move naturally when subject to temperature changes.

Expansion joints only need to be considered when the surfaces are rigid such as concrete pavements and paving units with cement joints. In such cases, expansion joints are required to protect the channel from lateral forces (exerted by expansion of the adjacent pavement), and to avoid cracking within the concrete encasement/ surround due to shrinkage. The expansion joints highlighted in this section are also required when modular 'grated' trench drain systems are installed on a rigid surface; the installation detail is the same.

We do not recommend that open expansion joints (left unfilled, with no expansion material) are used around Gatic Slotdrain channels. These can become filled with silt and debris over time, and then become ineffective.

Expansion Joint Material

The type, material and thickness of expansion joints used to provide these construction joints should ultimately be the choice of the project engineer, as they are more familiar with site conditions and characteristics. Most products should be readily available (or easily sourced) from the local market. The performance of the expansion joint product and material within the local environment should be assessed.

The thickness of the expansion joint material used will depend on the anticipated rate of expansion, which is a factor of the temperature differential in the local environment, the type of concrete and aggregate used, the thickness of the concrete pavement, the location and spacing of pavement expansion joints etc. There are many factors involved which may have an influence on the rate of movement of the concrete pavements adjacent to the channel. The expansion material used should be thick enough to cope with the anticipated movement and pressure exerted by the adjacent concrete pavements.

Common expansion materials used are fibre-board and 'Semi Cross Linked Polyethylene (Large Cell) Expansion Material'. We would not recommend that polystyrene is used, since this material does not regain its original dimensions once compressed.

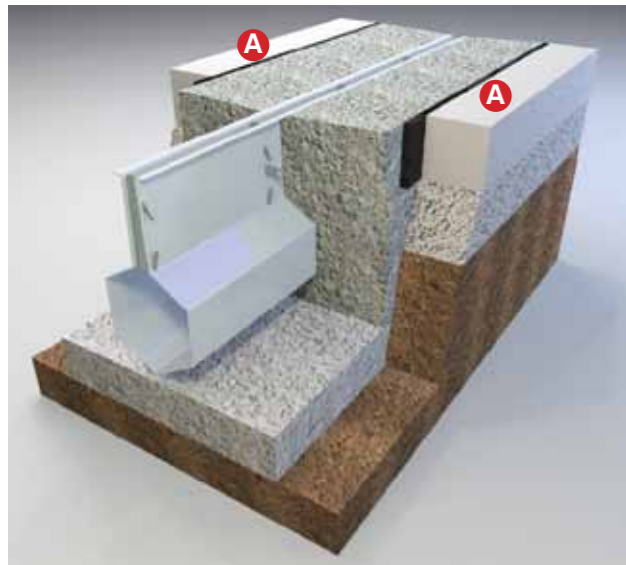

Longitudinal Joints **A**

For concrete pavement and other rigid surface installations, longitudinal expansion joints should be installed between the channel concrete encasement/surround and the adjacent pavement, on either side of the slot drain channel, approximately 200mm from the channel body.

Where access units and catch basins are installed, an expansion joint should be fitted around the outside of these units, between the concrete encasement/surround around the frame and the adjacent pavement.



Crack Control Joints

(Crack Inducers/Shrinkage Joints) **B**

These should be laid either side of the channel at 3m intervals (across the concrete encasement/surround). This detail is required for all modular channel systems installed in a concrete pavement.

Crack Control Joints can be formed in a variety of ways, including:

- Use standard expansion joint material.
- Purpose made two-part plastic Crack Control Joints.
- Concrete surround can be cut with a disc cutting tool after the concrete has cured.

We would recommend the use of a Two-Part Top-Type Crack Inducer similar to the image right. These are pushed into the concrete surface during the pouring and smoothing phase, and the top section is removed after curing to leave a sealant void.

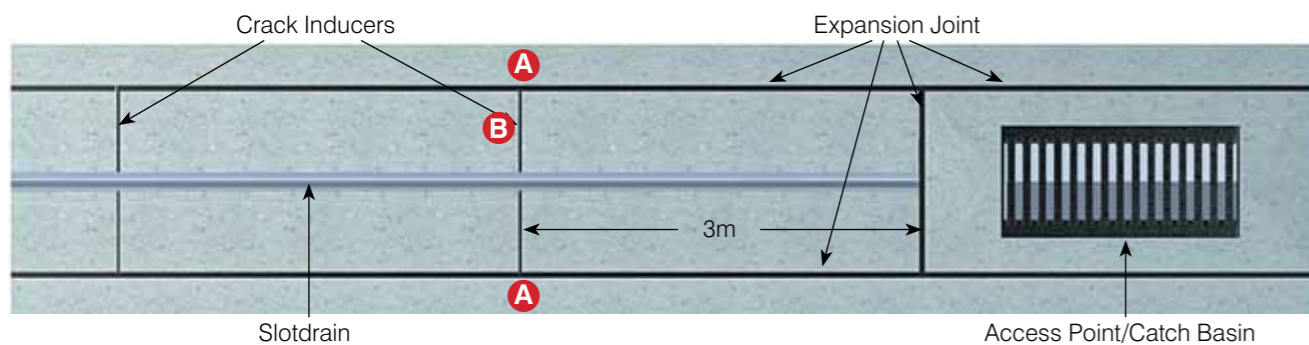
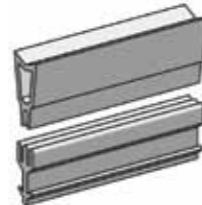

Cross-Section Expansion Joints



These may be considered when channels are installed in regions that experience very high environmental temperatures.

As Gatic Slotdrain is a modular system, the movement caused by linear expansion of channel units can most often be accommodated within the channel joints.

In regions where temperatures are very high, then linear expansion may be more extreme. The project engineer can consider the inclusion of a Cross-Section expansion joint that is installed between two channel units, to the full depth of the concrete surround. The decision to include these joints, and the intervals at which they should be installed along the channel run, should be determined by the project engineer.

FacadeSlot – Expansion Joints

An expansion joint will be required between the FacadeSlot channel, and the vertical structure against which the channel is being installed. Please refer to standard installation details provided by Gatic.

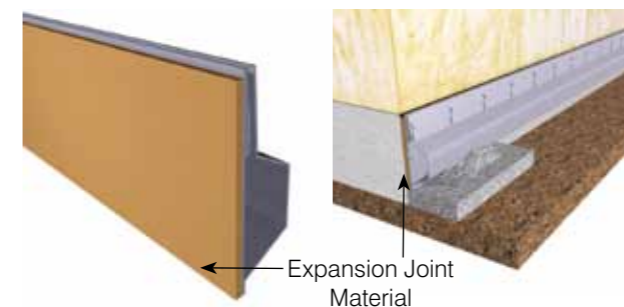

Expansion Joint Sealant

For all expansion joints, a flexible sealant should be used at the top surface to prevent ingress of water into the joint.

Asphalt & Paving Installations

When the channel concrete encasement/surround beneath the surface of the asphalt or paving will expand and contract at a different rate to the surface, and is not placed under the same lateral pressure as apparent in a concrete pavement installation.

The gaps between paving units generally have a loose infill with a granular base, so expansion and contraction occurs without exerting too much pressure on the channel. The Asphalt surface is also flexible, with a granular base, so again this type of installation does not induce the same level of pressure on the channel compared to a concrete pavement installation. Please refer to our installation details relating to Asphalt and Block Paving Installations.



The expansion joint detail relating to Asphalt and Paving Installations should be determined by the project engineer, as the types of installation detail can vary.

If large paving units are installed on a concrete base with mortar infill between joints, then this installation may react similar to a concrete pavement with regard to expansion and contraction. In such cases, it may be necessary to include both longitudinal expansion joints (running parallel to the channel) and cross-section expansion joints (running perpendicular to the channel). There are many decorative and discreet architectural expansion joints that can be used and are readily available on the market.

In a heavy-duty application such as an airport or port, if UltraSlot F900 channels are used and the surface finish is asphalt, then the asphalt surface should be laid to the edge of the channel concrete surround, and not laid directly against the channel edge. Crack Control Joints will still be required at every second channel joint.



In some projects there may be a requirement to install the slot drain system to follow a given radius, for example around the perimeter of a taxi-way on an airport project, or following the curve of a landscape feature.

Gatic Slotdrain channel units are available in straight lengths of 500mm, 1m or 3m.

Gradual Radii

These can be formed using standard units, with each consecutive channel unit positioned at a slight angle in relation to the previous channel. Please refer to the table below for the achievable radius for standard channels in the range.

When positioning channel units, the gap formed between channels on the outside edge of the radius should not exceed 5mm.



All gaps between the channel joints, on both sides of the channel, should be sealed with a strong construction tape prior to concreting.

Slotdrain Type and Length	Channel Width (mm)									
	50	75	100	115	150	225	300	400	500	600
FacadeSlot System 3m Channels	32m	48m		70m						
FacadeSlot System 1m Channels	13m	17m		25m						
FacadeSlot System 500mm Channels	6m	8m		12m						

Slotdrain Type and Length	Channel Width (mm)									
	50	75	100	115	150	225	300	400	500	600
Other Slotdrain Systems 3m Channels			64m		94m	139m	183m	244m	304m	363m
Other Slotdrain Systems 1m Channels			23m		32m	46m	62m	82m	103m	123m
Other Slotdrain Systems 500mm Channels			11m		16m	23m	31m	41m	51m	61m

A slot drain channel system will require access units to be placed in strategic locations along the channel run, to provide access into the system for cleaning and maintenance.

The position of access units should be determined by the client and project engineer, taking into account the maintenance equipment that will be used.

Specifiers may consider the following:

- Access units should be placed at the start of every channel run.
- Access units should be placed at every corner, or at the point where the channel changes direction.

- 100-300mm Wide Channels: Mid-run access units should be placed every 30-50m.
- 400-600mm Wide Channels: Mid-run access units should be placed every 75-100m.
- For short channel runs of 10m long or less, then channel end-caps may be sufficient at the start of the channel run, as cleaning can be carried out from the catch pit end.

Further advice and information is available from Gatic regarding the positioning of access units.

An access unit should always be placed in corner positions

Catch pit can be used as an access point for cleaning and rodding

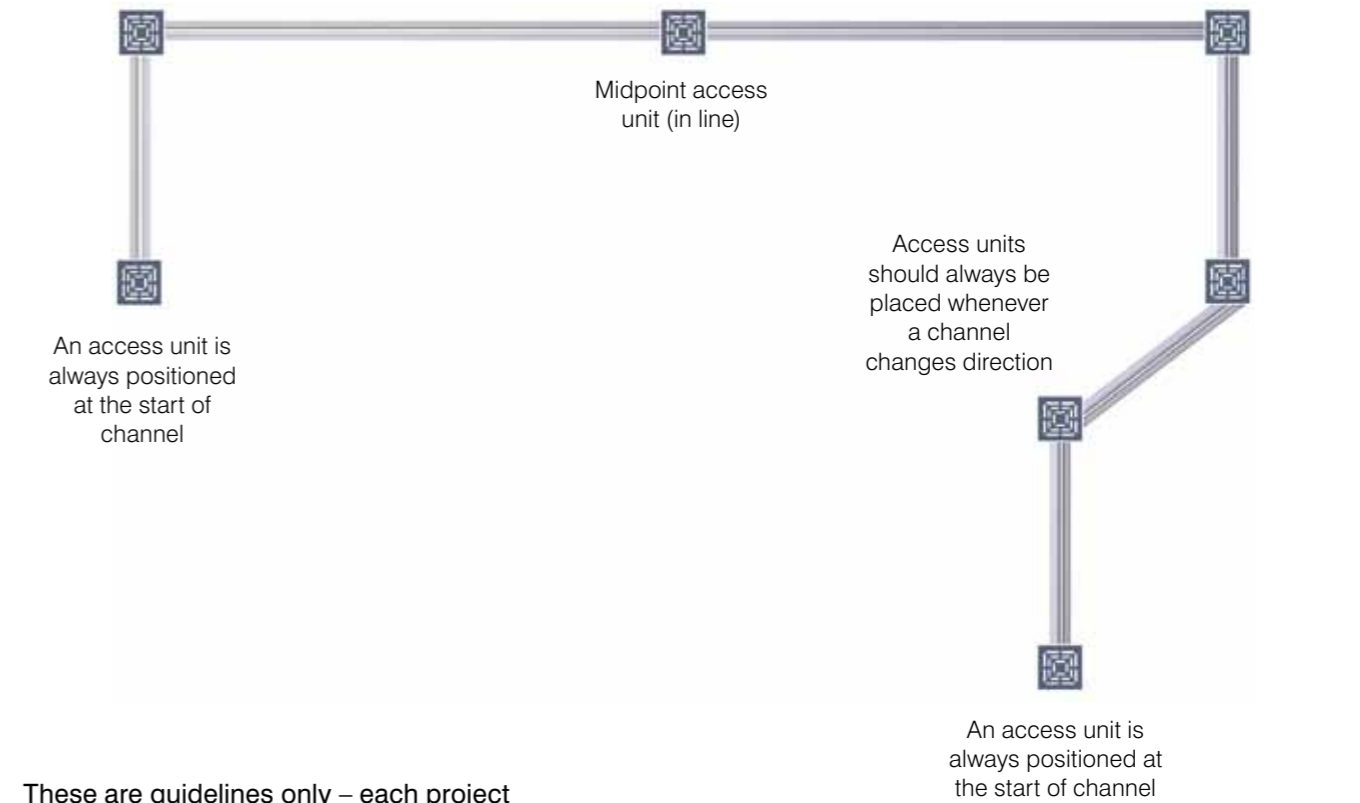

These are guidelines only – each project should be individually assessed regarding placement of access units.

Channel Size Options



	50mm	75mm	100mm	115mm	150mm	225mm	300mm	400mm	500mm	600mm
FacadeSlot	●	●		●						
PaveSlot			●		●	●	●	●	●	●
UniSlot			●		●	●	●	●	●	●
CastSlot 8 & 28 D400			●		●	●	●	●	●	●
CastSlot 8 & 28 F900					●	●	●	●	●	●
UltraSlot & UltraSlot Treadsafe					●	●	●	●	●	●

GATIC Slotrain® Specialised Engineering. Special Advice.

Gatic
Poulton Close
Dover
Kent CT17 0UF
United Kingdom

Tel no: +44 (0) 1304 203545
Fax no: +44 (0) 1304 215001
email: info@gatic.com
websites: www.gatic.com

Copyright GATIC – March 2012

GATIC is a division of Alumasc Ltd



Interactive Website

The redesigned GATIC website is ultra user-friendly and offers full details of the entire Slotrain range, its features and benefits, sizes and load categories, as well as design service and contact information. The new website also contains dedicated Access Covers and StreetWise sections.



Slotrain Lite Brochure

A Lite brochure that offers an overview of the Slotrain product range, including key applications, features and benefits.



Slotrain Handling, Installation and Maintenance Guide

Illustrated literature giving advice and general information on safe handling, installation and maintenance of Slotrain products.



Slotrain Design Software

This interactive software allows you to design your own Slotrain system using the same programme as our in-house design engineers. To be sent a CD containing this free software, simply register your details with us. You can do this on the MyGatic section of our website, or by emailing/phoning us using the contact information above.



Access Covers Product Selector Software

This new Gatic Access Covers Product Selector software is now available and can be sent to you on a CD for free. Simply register your details with us on the MyGatic section of our website, or by emailing / phoning us using the contact information above.