



Anti Terra Range

PAS 68 Hostile Vehicle Mitigation





FP2
Security Sliding Gates



FP2.1
Barricade Beams



FP3
Hinged/Swing Security Gates



FP4
Automatic Drop/Rising Arm Barriers



FP5
Road Blockers & Rising Kerbs



FP5.1
Rising & Static Bollards



FP6
Manual Perimeter Security



FP7
Pedestrian Gates & Turnstiles

Also available:

[Corporate Brochure](#)

[Your Guide to PAS 68](#)



Why Use Frontier Pitts Ltd? 4

Your Guide to PAS 68 6

Terra Sliding Gates 10-15

Including the Terra Sliding Cantilevered Gate, Terra Gate (tracked) & Terra Beam

Terra Swing Gates 16-23

Including the Terra Swing Gate, Terra Hinged Gate, Terra V Gate

Terra Drop Arm Barriers 24-31

Compact Terra Barrier, Original Terra Barrier, Terra Ultimate Barrier & Terra Manual Barrier

Terra Blockers 32-37

Surface, Shallow, Terra Blockers

Rising & Static Terra Bollards 38-43

Rising Terra Bollards, Static Terra Saturn Bollards, Static Terra Pyramid Bollards, Static Terra Jupiter Bollards, Static Terra Venus Bollards, Static Terra Mars Bollards, Static Terra Neptune Bollards

Terra Diamond Turnstile 44

LPS 1175 Security Rating 3 &4

Why Use Frontier Pitts?



From our UK HQ
in Crawley, West Sussex



Frontier Pitts is more than just a Manufacturer:

90 years experience & accredited to BSi ISO 9001

National & International. Installations in over 90 countries

95 directly employed personnel, including multi-lingual staff & personnel that have been Frontier Pitts for 30+ years

Technical Consultants based at regional offices will visit any site within the British Isles, without charge or obligation, offering technical advice on the most appropriate & effective perimeter security solutions. Including BSi PAS 68 & CEN CWA 16221 standards.

Directly employed sales & support staff

Large product portfolio to suit all budgets & requirements

Standard product specifications are complimented by our bespoke design service. Previous accomplishments include a sliding gate system which secures a 70 metre aperture

Full 3D CAD Design. Site specific drawings issued to clients

British Engineering - Designed & built to last

Mechanical & Electrical Engineering Research & Development Programs

Comprehensive Training Program; ensures the client always receives the very best of our technical expertise

Dedicated Project Manager for each project. All work is executed under the strict control of our specially trained PMs

Fleet of vehicles including HGV's to ensure the equipment is safely delivered to site, with full ID tracking for security



Highly skilled, dedicated Mechanical & Electrical Field Engineers

Installation, Commissioning, Service & Maintenance

24hr / 7days a week manned UK Call Centre & Nationwide Breakdown Service

A range of Maintenance Contracts available to suit individual site requirements

Maintenance Contracts with response times in as little as 4 hours
Comprehensive Customer Service

Highly skilled, directly employed engineers located nationally.
Frontier Pitts do not use Sub Contractors

Full Installation & Commissioning Service

Civil, Electrical & Ground Works Team

BSi ISO 9001 Accredited and LPCB approved to LPS 1175

Verified and Founder member of the PSSA - Perimeter Security Suppliers Association - with the aim to raise the standards of the industry.

In house resources & skills - IT, Engineering, Fabricating, Maintenance & Installation - to overcome any possible obstacle

Spares Department, holding on average £200K of stock

Frontier Pitts is highly recommended by our existing & previous customers

Extra Fast Repair & Refurbishment for existing customers.

Total customer care for your peace of mind

In house secure IT servers, latest software and hardware





Experience of 'List X' regulations and data security.

Accreditations



The Anti Terra range includes equipment successfully impact tested to the BSi PAS 68 specification. The different category ratings are all designed to illustrate how the perimeter security equipment will arrest an energy created by various masses and speeds, as illustrated below:

Vehicle & Vehicle Mass

MI	NI	N2	N3
			
1500kg	3500kg	7500kg laden	7500kg empty 8000kg
Speeds	30mph / 48kph	40mph / 64kph	50mph / 80kph

Vehicle Energy & Speed

The test criteria (vehicle weight and impact speed combinations) shall be selected from one of the combinations specified from Vehicle & Vehicle Mass and Speeds. Note: Under PAS68:2010 only an N3 vehicle may be used to test a product at 50mph (80kph).

Energy in Kilojoules (approximate values)

Vehicle Speed km/hour	Vehicle Weight kg			
	1500	2500	3500	7500
16	15	25	35	74
32	59	99	138	296
48	133	222	311	667
64	237	395	553	1185
80	370	617	864	1852

When specifying your PAS 68 equipment, first establish what speed the different types of vehicles could reach on site before approaching the barrier & therefore how much energy the barrier may need to stop.

For further information please see Frontier Pitts "Your Guide to PAS 68" or contact the PAS 68 Specialist Technical Consultant on 01293 422800

Which category rating do you require?

Many projects are now specifying BSi PAS 68 equipment, not only for the counter terrorist benefits but also for the heavy duty properties of the equipment. However, there are many different test criteria of BSi PAS 68, depending on the kinetic energy values as described on page 3.

It is very important to know which level of BSi PAS 68 is required as there could potentially be a cost difference of thousands of pounds between each category. Equipment that has been successfully impact tested in accordance with BSi PAS 68 is given a 5-7 part classification code to help identify the products performance, depending on test date.

Classification Code - Vehicle Impact Test

BSi PAS 68	1	2	3	4	5	6	7
2007 edition	V	Terra Blocker	7500 N2	80	n/a	0	5.2
2010 edition	V	Terra Blocker	7500 N2	80	90	0	5.2

7 Part Description:-

- Classification of Test: Depending on the year of the test the following will be used:
 - V = Impact Test – Actual vehicle impact tested to repeatable scientific condition
 - F = Computer simulation FEA or Design method (check validation body)
 - P = Pendulum testing weight used for bollards instead of vehicles (this test method has been removed from BSi PAS 68:2010).
- A retractable road blocker;
- Capable of withstanding an impact by a 7500kg rigid vehicle at 50mph (80kph). Note: Under PAS68:2010 only an N3 vehicle may be used to test a product at 50mph (80kph).
- Impact speed at 50mph (80kph);
- BSi PAS 68: 2010 – Angle of test impact. The majority of impacts are head on, i.e. 90 degrees. Other approach impact angles may have been tested i.e. Fencing at 45 degrees. N/A to BSi PAS 68:2007
- Where the vehicle penetrated 0.0m beyond the original position of the rear face of the blocker: i.e. How far into site the test vehicle would stop. Note: With surface mounted products, check how far the arresting equipment travelled on impact.
- Where major debris landed beyond the original position the rear face of the blocker. Major debris is classed as 25kg or more. This is important when trying to maintain a "stand off" from building.



In many specifications only parts 2, 3 and 4 are detailed, but the other parts are just as important and need to be clarified.

NOTE: When specifying BSi PAS 68 products the short hand or long hand information must be given.

Frontier Pitts high security HVM Anti Terra Range has been successfully impact tested in accordance to BSi PAS 68, stopping & immobilising a vehicle at various energies (typically 7500kg travelling at 50mph which equates to 1852kj)

Vehicle Test Weight (kg)	Vehicle Class	Vehicle Speed (kph)	Vehicle Angle	Vehicle Penetration	Dispersion
--------------------------	---------------	---------------------	---------------	---------------------	------------



Terra Sliding Cantilevered Gate

The Terra Gate Mk II Impact tested to BSi PAS 68 & CEN CWA 16221

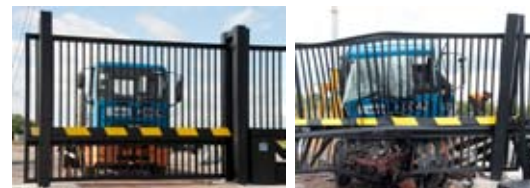

7500kg	N3	80	90	1.5	0.0
--------	----	----	----	-----	-----



Terra Gate - Tracked

Sliding Gate successfully PAS 68 impact tested in the fully closed & half open positions. Fully functional after impact



7500kg	N3	80	90	0.0	0.0
7500kg	N3	80	90	0.0	0.0

Terra Blocker - Surface, Shallow & Original

successfully impact tested to PAS 68 & K12



7500kg	N3	80	90	0.0	7.6
7500kg	N3	80	90	0.0	25.0
7500kg	N3	80	90	4.0	25.0
7500kg	N3	80	90	13.5	25.0
7500kg	N3	80	90	0.0	0.0

Vehicle Test Weight (kg)	Vehicle Class	Vehicle Speed (kph)	Vehicle Angle	Vehicle Penetration	Dispersion
--------------------------	---------------	---------------------	---------------	---------------------	------------

Terra Barriers includes the Terra Ultimate Barrier, Compact Terra Barrier & Terra Manual Barrier



7500kg	N3	80	90	5.3	2.0
7500kg	N3	64	90	0.0	25.0
7500kg	N1	48	90	1.5	0.0
7500kg	N2	48	90	0.0	0.0

Terra Swing Gate, Terra Hinged Gate & Terra V Gate



7500kg	N3	80	90	0.0	25.0
7500kg	N3	80	90	0.0	0.0

Terra Bollards, Rising & Static

successfully impact tested to PAS 68 & K12

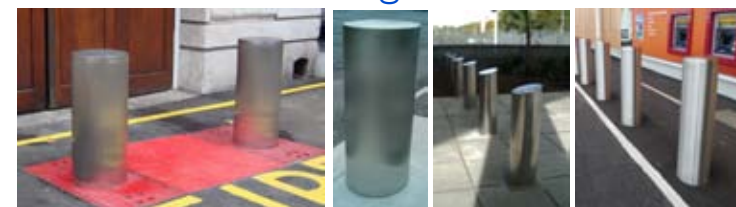

Terra Pyramids Bollards
Terra Alloy Bollards
Terra Jupiter Bollards
Terra Mars Bollards
Terra Neptune Bollards
Terra Venus Bollards

7500kg	N2	80	90	5.0	9.2
7500kg	N2	48	90	1.71	0.0
7500kg	N1	48	90	0.0	0.0
7500kg	N2	80	90	10.6	11.1
7500kg	N2	64	90	4.0	16.7
7500kg	N2	64	90	3.3	0.0
7500kg	N2	48	90	0.0	0.0

The PAS 68 Sliding Cantilevered Gate from Frontier Pitts successfully PAS 68 impact tested with a 7500kg vehicle travelling at 50mph



PAS 68 Terra Sliding Cantilevered Gate

Also known as the Terra Gate MkII

V Sliding Gate 7500[N3]/80/90:1.5/0.0
 Tested dimensions: width 4500mm, height 3000mm
 Maximum width: 6000mm

Applications: Sites that require equipment that meets a high level of the PAS 68 specification

High Security | Anti Terrorist | Government | Military | Embassies | Banks | Utilities | Airports



Terra Gate MkII Pre Test



Terra Gate MkII Post Test



Option of an UPS (Uninterrupted Power Supply) is available if the gate is required to be re-opened during power failure.

DUTY CYCLE – 100%

OPERATING SPEED
 Typical operating speed of 250-500mm/second*, depending on configuration.

OPTIONAL ACCESSORIES
 UPS (Uninterrupted Power Supply)
 EFO (Extra Fast Operation)
 Disengaging box - manual override
 100/200mm Traffic Light System
 High Security Cabinet

SAFETY - Option of vehicle detector loops and safety photocell beams, flashing beacon, audible alarm, safety edge, etc

CIVIL REQUIREMENTS
 Gate Base Foundation
 L:2800mm x W:1500mm x D:500mm
 (Note: Power and control wiring ducts to be incorporated into foundations)

Receptor Post Foundation
 L:2800mm x W:1500mm x D:500mm

ELECTRICAL REQUIREMENTS POWER
 Three Phase Supply and Neutral

*This is subject to a risk assessment to ensure the automatic equipment complies to BS EN 12453

Successfully impact tested to the latest BSi PAS 68:2010 specification stopping a 7500kg N3 vehicle travelling at 50mph (80kph) which equates to 1852kj

Maximum crash beam length 6000mm
 Power is supplied from a three phase and neutral supply.
 Designed for easy installation and maintenance.

The Terra Sliding Cantilevered Gate can be interfaced to any access control systems.

BENEFITS & FEATURES

- Minimal site penetration
- Variable heights available (standard 2400mm) up to 5000mm
- Shallow foundation depths of only 500mm required
- Gate leaf with Heavy Duty Crash Impact Beam.
- Heavy duty posts support the gate leaf
- Cantilevered Gate, no track or support across the roadway is required, therefore no roadway excavation required
- The balance is provided by a unique enclosed "runback" which enables the gate to be fully projected across the roadway without tipping
- Electronic control motor drive unit
- Manual operation under power fail conditions
- Retro fit possible to existing gate on site.
- Successfully impact tested to the latest BSi PAS 68:2010 specification stopping a 7500kg N3 vehicle travelling at 50mph (80kph) which equates to 1852kj



The only PAS 68 Sliding Gate in the world to be impact tested in the fully closed & half open positions, and remain fully functional after impact.



PAS 68 Terra Gate (Tracked)

Impact tested in the fully closed position & half open positions.
 V Sliding Gate 7500[N3]/80/90:0.0/0.0
 Tested dimensions : width 3000mm, height 3000mm
 Maximum width: 6000mm

Applications: Sites that require a high level of PAS 68 security

High Security | Anti Terrorist | Government | Military | Embassies | Banks | Utilities | Airports



Terra Gate with standard bar



PAS 68 Terra Gate impact test in the half open position



PAS 68 Terra Gate impact test in fully closed position



Option of an UPS (Uninterrupted Power Supply) is available if the gate is required to be re-opened during power failure.

DUTY CYCLE – 100%

OPERATING SPEED

Typical operating speeds of 250-2000mm/second* depending on configuration

OPTIONAL ACCESSORIES

- UPS (Uninterrupted Power Supply)
- EFO (Extra Fast Operation)
- Disengaging box - manual override
- 100/200mm Traffic Light System
- High Security Cabinet

SAFETY - Option of vehicle detector loops and safety photocell beams, flashing beacon, audible alarm, safety edge, etc

CIVIL REQUIREMENTS

Gate Base Foundation
 L:4000mm x W:2000mm x D:280mm
 (Note: Power and control wiring ducts to be incorporated into foundations)

Receptor Post Foundation
 L:4000mm x W:2000mm x D:280mm

ELECTRICAL REQUIREMENTS POWER
 Three Phase Supply and Neutral

*This is subject to a risk assessment to ensure the automatic equipment complies to BS EN 12453

Successfully impact tested in accordance with BSi PAS 68 specification stopping a 7500kg vehicle travelling at 50mph (80kph) which equates to 1852kj.

Maximum crash beam length 6000mm
 Power is supplied from a three phase and neutral supply.
 Designed for easy installation and maintenance.

The Terra Gate can be interfaced to any access control systems.

BENEFITS & FEATURES

- Zero site penetration
- Fully functional after impact, even after crash test in the half open position
- Variable heights available up to 5000mm (std 2400mm)
- Shallow foundation depths of only 300mm required
- Gate leaf with Heavy Duty Crash Impact Beam.
- Heavy duty posts support the gate leaf
- Electronic control motor drive unit
- Manual operation under power fail conditions



The Terra Beam is based on the design of the PAS 68 Terra Sliding Cantilevered Gate.



Terra Beam

Based on the PAS 68 Terra Sliding Cantilevered Gate
 V Sliding Gate 7500[N3]/80/90:0.0/0.0
 Tested dimensions : width 3000mm
 Maximum width: 6000mm

Applications: Sites that require a high level of PAS 68 security

High Security | Anti Terrorist | Government | Military | Embassies | Banks | Utilities | Airports



Based on the PAS 68 impact tested Terra Sliding Cantilevered Gate



Team Beam whilst open



Terra Beam design in based on the PAS 68 Terra Sliding Cantilevered Gate



Option of an UPS (Uninterrupted Power Supply) is available if the gate is required to be re-opened during power failure.

DUTY CYCLE – 100%

OPERATING SPEED
 Typical operating speeds of 250-500mm/seconds*, depending on length and configuration.

OPTIONAL ACCESSORIES
 UPS (Uninterrupted Power Supply)
 EFO (Extra Fast Operation)
 Disengaging box - manual override
 100/200mm Traffic Light System
 High Security Cabinet

SAFETY - Option of vehicle detector loops and safety photocell beams, flashing beacon, audible alarm, safety edge, etc

CIVIL REQUIREMENTS
 Beam Base Foundation
 L:2500mm x W:3500mm x D:500mm
 (Note: Power and control wiring ducts to be incorporated into foundations)

Receptor Post Foundation
 L:2500mm x W:3500mm x D:500mm

ELECTRICAL REQUIREMENTS POWER
 Three Phase Supply

*This is subject to a risk assessment to ensure the automatic equipment complies to BS EN 12453

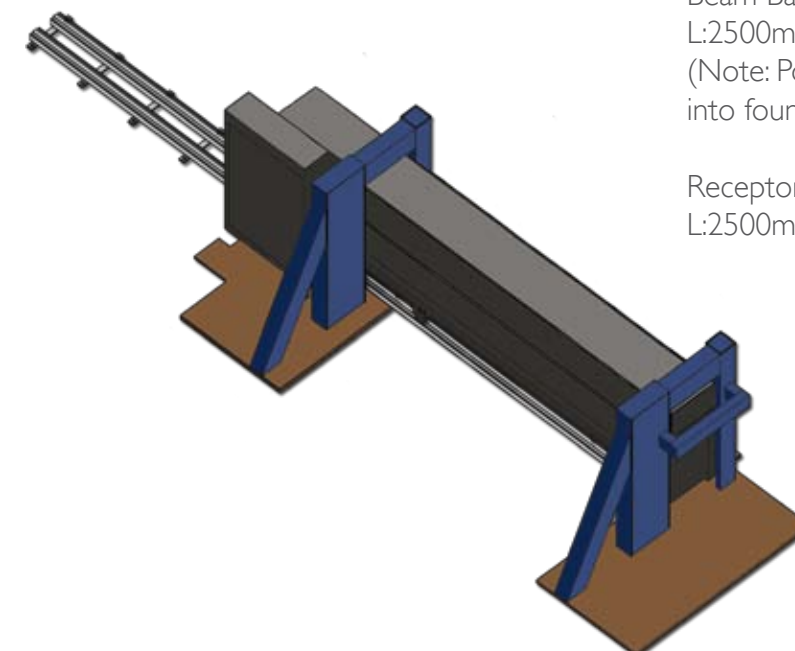

The Terra Beam is based on the Terra Sliding Cantilevered Gate which has been successfully impact tested to the latest BSi PAS 68:2010 specification stopping a 7500kg vehicle travelling at 50mph (80kph) which equates to 1852kj.

Maximum crash beam length 6000mm.

Power is supplied from a three phase and neutral supply.

Designed for easy installation and maintenance.

The Terra Beam can be interfaced to any access control systems.

BENEFITS & FEATURES

- Based on the PAS 68 impact tested Terra Sliding Cantilevered Gate which has been successfully impact tested to the latest BSi PAS 68:2010 specification stopping a 7500kg N3 vehicle travelling at 50mph (80kph) which equates to 1852kj
- Zero site penetration
- Shallow foundation depths of only 300mm required
- Heavy Duty Crash Impact Beam.
- Heavy duty posts support the beam
- Electronic control motor drive unit
- Manual operation under power fail conditions



The PAS 68 manual swing arm gate from Frontier Pitts



PAS 68 Terra Swing Gate
(previously known as the Terra Road Closer)

V Swing Barrier 7500[N3]/80/90:0.0/25.0
Tested dimensions : width 3500mm
Maximum width: 6000mm
crash beam height : 720mm

Applications: High Security sites which require PAS 68 equipment at a location with no power supply, height restriction or lack of runback area for sliding gate.

High Security | Anti Terrorist | Government | Military | Airports | Industrial



Successfully impact tested in accordance to BSi PAS 68 specification stopping a 7500kg vehicle travelling at 50mph (80kph) which equates to 1852kj.

Maximum crash beam length 6000mm

The Terra Swing Gate is a manual swing barrier, with integrated crash beam. Designed for ease of installation and maintenance.

BENEFITS & FEATURES

- Shallow foundation depths of only 350mm required
- Heavy Duty Crash Impact Beam with Heavy duty post supports.
- Manual operation.
Ideal for remote locations on sites where there is no power supply available.



Terra Swing Gate secured in the open position



Locking Pin securing crash beam into closed position

CIVIL REQUIREMENTS

Posts Foundation
L:4000mm x W:1750mm x D:350mm



Adding a weldmesh infill to the PAS 68 Terra Swing Gate creates the Terra Hinged Gate



Terra Hinged Gate

PAS 68 Terra Swing Gate classification code
 V Swing Gate 7500[N3]/80/90:0.0/25.0
 Tested dimensions : width 3500mm,
 Maximum width 6000mm
 crash beam height 1000mm

Applications: High Security sites which require PAS 68 equipment at a location with no power supply, height restriction or lack of runback area for sliding gate.

High Security | Anti Terrorist | Government | Military | Airports | Industrial



The Terra Hinged Gate is the enhanced version of the Terra Swing Gate which has been successfully impact tested in accordance to the BSi PAS 68 specification stopping a 7500kg N3 vehicle travelling at 50mph (80kph), at a width of 3500mm. Maximum crash beam length 6000mm.

The Terra Hinged Gate is a manual swing gate, with integrated crash beam and weldmesh infill, which can be automated. Please contact the Technical Sales Department on 01293 422800 for more information. Designed for easy installation and maintenance.

BENEFITS & FEATURES

- Shallow foundation depths of only 350mm required
- Heavy Duty Crash Impact Beam with Heavy duty post supports and high security infill.
- Range of security infills available.
- Manual operation as standard. Ideal for remote locations on sites where there is no power supply available.
- Can easily be automated using a wide range of Actuators. Please see page 22



CIVIL REQUIREMENTS

Posts Foundation
 L:4000mm x W:1800mm x D:500mm

Similarly to the Terra Swing Gate, the Terra Hinged Gate can be automated.

Please contact the Technical Sales Department on 01293 422800 for more information.

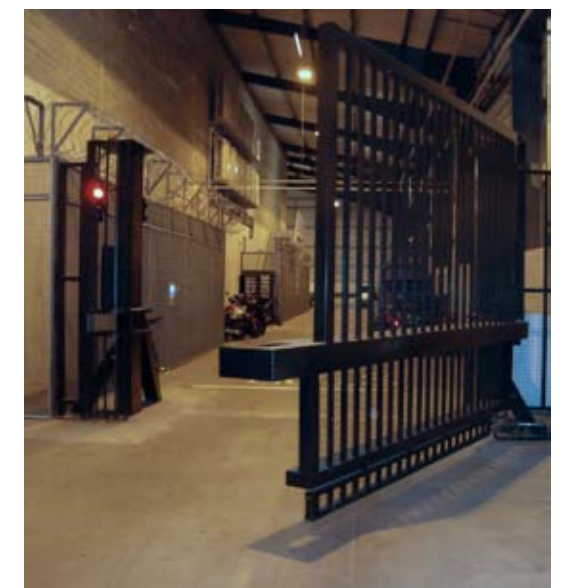

Terra Hinged Gate opening



The PAS 68 Terra V Gate is a pair of bi-parting hinged gate leaves that secure in a shallow 'V' shape.



PAS 68 Terra V Gate
(previously known as Terra Lock Gate)

V Bi-parting Hinged Gate 7500[N3]/80/90:0.0/0.0
Tested dimensions : width 4000mm, height 3000mm
Maximum width: 9000mm

Applications: Sites that require a high level of PAS 68 security

High Security | Anti Terrorist | Government | Military | Embassies | Banks | Utilities | Airports



Successfully impact tested in accordance to the BSi PAS 68 specification stopping a 7500kg N3 vehicle travelling at 50mph (80kph) which equates to 1852kj

Maximum width 9000mm

The Terra V Gate is a manual swing gate, with integrated crash beam, which can be automated. Please contact the Technical Sales Department on 01293 422800 for more information. Designed for easy installation and maintenance.

BENEFITS & FEATURES

- Zero site penetration
- Fully functional after impact
- Variable heights available (standard 3000mm)
- Shallow foundation depths of only 340mm required
- Bi-parting pair of hinged gate leaves with Heavy Duty Crash Impact Beam.
- Heavy duty posts support the gate leaf
- Secured at a shallow angle of only 135 degrees

CIVIL REQUIREMENTS

Each post foundation
L:4500mm x W:2500mm x D:340mm



Locking Pin securing gate leaves into closed position



Locking Pin



Pre PAS 68 impact test



Fully functional post PAS 68 impact test



Fully functional post PAS 68 impact test



Actuators

A range of powerful motive units to automate Terra Hinged Gates & Terra V Gates

Applications: Automation of Terra Hinged Gates & Terra V Gates



Locking Pin securing gate leaves into closed position

GATE BACK ACTUATORS

A small but powerful motive unit, which provides a low cost solution for powering small hinged gates (maximum gate aperture 5 metres). Designed for continuous operation, it has a standard operating speed of 10-18 seconds*. Supplied with Frontier Pitts hinged gates or alternatively retro-fitted to existing gates.

The actuator is a powerful hydraulic ram which is mounted between the gate-leaf and the gate hinge-post. A hinge-post mounting bracket is bolted to the gate post and offsets the rear of the ram to produce the correct operating geometry. The forces generated act directly upon the rear of the gate-leaf and produce the required rotation. The small outline of the actuator creates the minimum visual impact for decorative gate installations.

**This is subject to a risk assessment to ensure the automatic equipment complies to BS EN 12453*



Heavy Duty Gate Back Actuator (covers removed)



Underground Trojan Actuator

TROJAN ACTUATORS

A range of powerful motive units for large, heavy gates. Originally designed by Frontier Pitts to automate large prison gates.

100% duty cycle designed for continuous operation with standard operating speeds of 9-13 seconds*. A 5 ton leaf can have an operating speed of just 3 seconds*.

Underground and surface mounted models available of the Trojan actuator. The Trojan underground actuator is completely contained below the surface directly under the gate leaf hinge-point creating minimal visual impact

It provides a powerful motive unit for the operation of a large, hinged gate-leaf. The actuator is housed within an underground cavity formed in the gatepost foundation immediately underneath the pivot point of the gate-leaf. A sturdy 10mm steel cover plate is fitted which protects the actuator from the elements and allows service access. The actuator cav
CIVIL REQUIREMENTS
Dependent on Automation - please contact the Technical Sales Department on 01293 422800

CIVIL REQUIREMENTS
Dependent on Automation - please contact the Technical Sales Department on 01293 422800

ELECTRICAL REQUIREMENTS
Single phase or three phase options available.
**This is subject to a risk assessment to ensure the automatic equipment complies to BS EN 12453*



Surface Mounted Trojan Actuator

ELECTRICAL LOCKING BOLT

Designed for frequent and arduous operation. The bolt only requires electrical operation to release electrical operation to release the gate leaf. When the gate leaf reaches the locking position the mechanical design allows the drop-bolt to engage automatically.



Electric Locking Bolt

Looks can be deceiving!

The BSi PAS 68:2010 impact tested Drop Arm Barrier that looks like a standard car park barrier, hydraulically powered for reliability & strength.



PAS 68 Compact Terra Barrier

V Drop Arm Gate 3500[NI]/48/90:1.5/0.0
 Tested dimensions : width 4000mm,
 Maximum width: 6000mm



Compact Terra Barrier post impact test



Applications: Sites that require a subtle security solution with the PAS 68 specification.

High Security Car Parks | Anti Terrorist | Government
 Military | Airports | Industrial | Commercial



Compact Terra Barrier raising

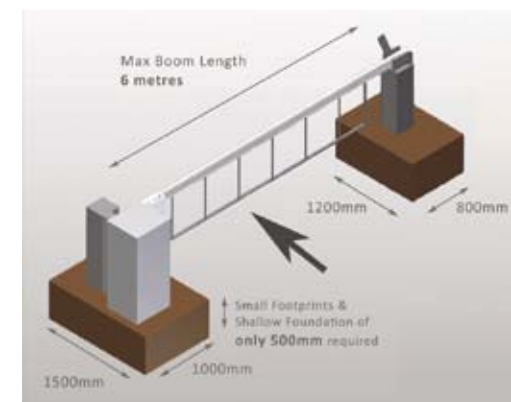

In event of Power Failure
 Fail safe (remain in raised position)
 Fail secure (remain in lowered position)

Option of a hand pump is available if the barrier is to be re-raised during power failure.

DUTY CYCLE – 100%

OPERATING SPEED
 Typical operating speeds of 5-12 seconds, depending on boom length & configuration.*

OPTIONAL ACCESSORIES
 EFO (Extra Fast Operation)
 100/200mm Traffic Lights
 Manual Hand pump
 High Security Cabinet

SAFETY - Option of vehicle detector loops and safety photocell beams.

Barrier Cabinet size
 L:522mm x W:472mm x H:1145mm

CIVIL REQUIREMENTS
 Barrier Base Foundation
 L:1500mm x W:1000mm x D:500mm
 (Note: Power and control wiring ducts to be incorporated into foundations)

End Rest Foundation
 L:1200mm x W:800mm x D:500mm

ELECTRICAL REQUIREMENTS
 6 amp, 5 wire, three phase and neutral or
 10 amp, 3 wire single phase
 * This is subject to a risk assessment to ensure the automatic equipment complies to BS EN 12453

Successfully impact tested to the latest BSi PAS 68:2010 specification stopping a 3500kg vehicle travelling at 30mph (48kph) which equates to 311kj

Maximum crash beam length 6000mm

The Compact Terra Barrier bridges the gap between the Heavy Duty HB Barrier & the PAS 68 Terra Barrier (see page 26).

Hydraulically driven barrier. Designed for ease of installation and maintenance.

The Compact Terra Barrier can be interfaced to any access control systems.

BENEFITS & FEATURES

- Looks like a standard car park barrier
- Hydraulically operated, single or three phase
- Aluminium boom with the latest PST (Perimeter Security Technology)
- 100% duty rating
- Instantly reversible
- Boom length up to 6 metres
- Impact tested to the latest BSi PAS 68:2010 specification
- Lower folding skirt as standard

The original PAS 68 impact tested Drop Arm Barrier, hydraulically powered for reliability & strength.



PAS 68 Terra Barrier

V Drop Arm Gate 7500[N2]/64/90:0.0/0.0
 Tested dimensions : width 3500mm,
 crash beam height 1050mm
 Maximum width: 4500mm



Successfully impact tested to the BSi PAS 68 specification stopping a 7500kg N2 vehicle travelling at 40mph (64kph) which equates to 1185kj

Maximum aperture 4500mm

Hydraulically driven barrier. Designed for ease of installation and maintenance.

The Terra Barrier can be interfaced to any access control systems.

BENEFITS & FEATURES

- No penetration into site.
- Hydraulically operated, three phase supply
- 100% duty rating
- Instantly reversible
- Impact tested to BSi PAS 68
- A wide range of Accessories are available, including lower



Applications: Sites that require equipment that meets a higher level of the PAS 68 specification.

High Security | Anti Terrorist | Government | Military | Airports | Industrial | Commercial



Terra Barrier post impact test



Terra Barrier with counterbalance & fully height swivel skirt

In event of Power Failure
 Fail safe (remain in raised position)
 Fail secure (remain in lowered position)

Option of a hand pump is available if the barrier is to be re-raised during power failure.

DUTY CYCLE – 100%

OPERATING SPEED
 Typical operating speeds of 5-14 seconds, depending on boom length & configuration.*

OPTIONAL ACCESSORIES
 EFO (Extra Fast Operation)
 100/200mm Traffic Lights
 Manual Hand pump
 High Security Cabinet

SAFETY - Option of vehicle detector loops, safety photocell beams & safety edges.

Barrier Cabinet size
 L:1320mm x W:1800mm x H:1540mm

CIVIL REQUIREMENTS
 Barrier Base Foundation
 L:4000mm x W:2000mm x D:460mm
 (Note: Power and control wiring ducts to be incorporated into foundations)

End Rest Foundation
 L:4000mm x W:1600mm x D:460mm

ELECTRICAL REQUIREMENTS
 10 amp, 5 wire, 400V, 50Hz, Three phase and neutral supply

*This is subject to a risk assessment to ensure the automatic equipment complies to BS EN 12453

The ULTIMATE PAS 68 drop arm barrier from Frontier Pitts. Successfully impact tested to the latest BSi PAS 68:2010 specification against a range of different energies. The Ultimate Solution.



PAS 68 Terra Ultimate Barrier

V/7500[N3]/80/90:5.3/2.0
 Tested dimensions : width 4500mm,
 crash beam height 1050mm
 Maximum width: 4500mm

Applications: Sites that require equipment that meets an even higher level of the PAS 68 specification.

High Security | Anti Terrorist | Government | Military | Airports | Industrial | Commercial



Terra Ultimate Barrier with underrun skirt was also successfully BSi PAS 68 impact tested with a 1500kg saloon car to test the barrier with different energies. Classification code: V/1500[M1]/80/90:11.3/15.0
 Tested dimensions : width 4500mm, crash beam height 900mm



In event of Power Failure
 Fail safe (remain in raised position)
 Fail secure (remain in lowered position)

Option of a hand pump is available if the barrier is to be re-raised during power failure.

DUTY CYCLE – 100%

OPERATING SPEED
 Typical operating speeds of 8-14 seconds to raise, depending on boom length & configuration.*

OPTIONAL ACCESSORIES
 EFO (Extra Fast Operation)
 100/200mm Traffic Lights
 Manual Hand pump
 High Security Cabinet
 Remote Hydraulic Power Unit



SAFETY - Option of vehicle detector loops and safety photocell beams.

Barrier Cabinet size
 L:980mm x W:1400mm x H:1055mm

CIVIL REQUIREMENTS
 Barrier Base Foundation
 L:2800mm x W:2040mm x D:400mm deep
 (Note: Power and control wiring ducts to be incorporated into foundations)

End Rest Foundation
 L:2800mm x W:1540mm x D:400mm

ELECTRICAL REQUIREMENTS
 10 amp, 5 wire, 400V, 50Hz, Three phase and neutral supply
 *This is subject to a risk assessment to ensure the automatic equipment complies to BS EN 12453

Successfully impact tested to the latest BSi PAS 68:2010 specification stopping a 7500kg vehicle travelling at 50mph (80kph) which equates to 1852kj.

Maximum aperture 4500mm

Hydraulically driven barrier. Designed for ease of installation and maintenance.

The Terra Ultimate Barrier can be interfaced to any access control systems.

BENEFITS & FEATURES

- Hydraulically operated, three phase supply
- 100% duty rating, reversible
- Impact tested to the latest BSi PAS 68:2010 specification
- The beam was retested for with underrun skirt to test arresting capability on other vehicles such as saloon car vehicles
- The Terra ULTIMATE Barrier will stop low & high energy vehicles from entering site
- A wide range of Accessories are available, including lower folding skirts and full height swivel skirt options.

The PAS 68 Manual Drop Arm Barrier
British Government design & PAS 68 impact tested as the 'MRAG' - Manual Rising Arm Gate



PAS 68 Terra Manual Barrier

V Drop Arm Gate - 7500[N2]/48/90:0/0
3500[N1]/80/90:4.0/0
3500[N1]/80/90:2.23/0
Tested dimensions : width 3000mm & 4500mm,
crash beam height 900mm



Maximum crash beam length 4500mm

The Terra Manual Barrier is a PAS 68 counter balanced barrier ideal for remote locations where no power is available.

BENEFITS & FEATURES

- Design of her Majesty's Government manufactured by Frontier Pitts.
- Non powered rising/drop arm barrier
- Boom length up to 4500mm
- Impact tested to BSi PAS 68:2010



The Award Winning PAS 68 Road Blocker from Frontier Pitts.

The ONLY surface mounted blocker to be successfully impact tested to the BSi PAS 68 standard with zero penetration AND remain bolted in its original position during and after impact.



PAS 68 Terra Surface Mount Blocker

V Road Blocker 7500[N3]/80/90:0.0/7.6
Tested dimensions : width 2500mm,
lift height 1100mm
maximum width 4000mm

Applications: Inner city locations with limited foundation depths that require equipment with a higher level of PAS 68 rating

High Security | Anti Terrorist | Government Institutions | Military Bases | Airports



Successfully impact tested to the latest PAS 68:2010 specification stopping a 7500kg vehicle travelling at 50mph (80kph) which equates to 1852kj. Maximum width 4000mm. Surface Mounted.

The unit is mounted on the road surface, therefore no foundations are required. The special pre formed ramps allow safe passage by all vehicles. The tarmac covering provides an anti slip surface for cyclists. Flush mount installation also available. Hydraulically driven. Designed for ease of installation and maintenance. The Terra Surface Mount Blocker can be interfaced to any access control systems.



BENEFITS & FEATURES

- Impact tested to BSi PAS 68:2010 - resulting in zero penetration
- Road surface blocker - no foundations required. Ideal for inner city sites
- Can also be installed flush with ground - foundation depths of only 220mm required.
- Hydraulically operated 400V
- 100% duty rating
- Instantly reversible
- Width up to 4 metres (securing apertures of 5.8m)
- Concertina safety skirt to prevent potential trapping areas.
- Wide range of Accessories available.
- Control cabinet recommended to be installed within 10 metres of unit.
- Further bespoke systems available.

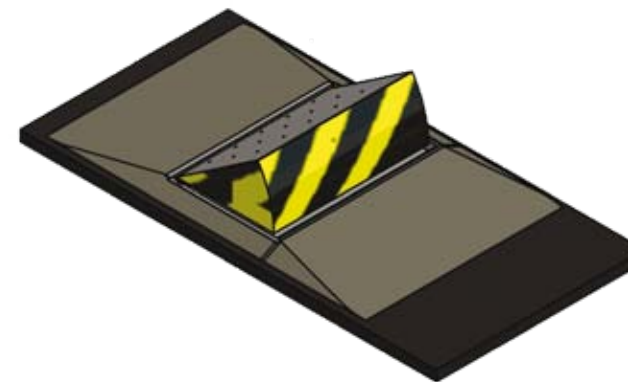

In event of Power Failure
Fail safe (remain in raised position)
Fail secure (remain in lowered position)

Option of an automatic Accumulator or manual hand pump is available if the blocker is to be re-raised during power failure.

DUTY CYCLE – 100%

OPERATING SPEED

Typical speeds of 4-6 seconds* depending on configuration. EFO (extra fast operation) in up to 1 second.

OPTIONAL ACCESSORIES - Please see page 36

- Accumulator – allows a number of operations in power failure mode
- EFO (Extra Fast Operation)
- 100/200mm Traffic Light System
- Manual Hand pump
- High Security Cabinet

SAFETY - Option of vehicle detector loops and safety photocell beams

CIVIL REQUIREMENTS

Minimum depth of 150mm
(Note: Power and control wiring ducts may be required).

Control Cabinet Foundation
L:600mm x W:900mm x D:300mm

ELECTRICAL REQUIREMENTS POWER

Three Phase Supply

*This is subject to a risk assessment to ensure the automatic



PAS 68 Terra Shallow Blocker

V Road Blocker 7500[N3]/80/90:0.0/25
Tested dimensions : width 2500mm,
lift height 1100mm
maximum width: 4000mm

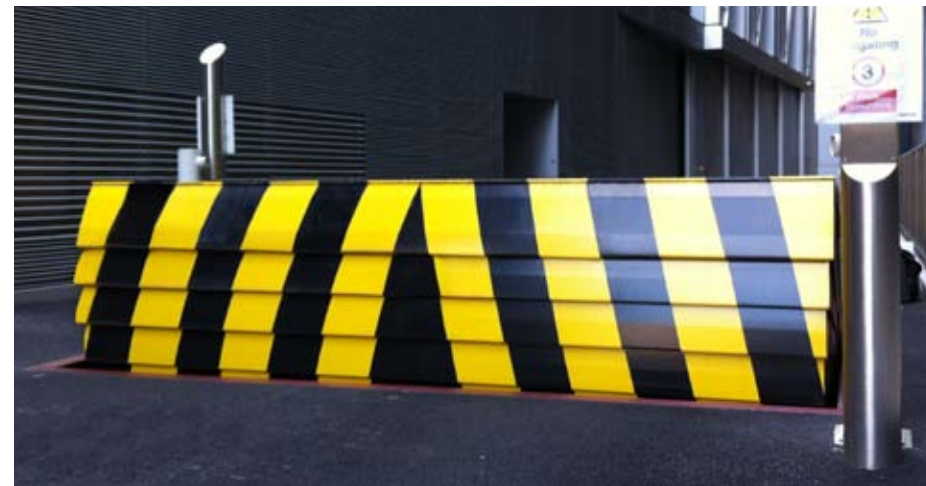

Successfully impact tested to the latest BSi PAS 68:2010 specification stopping a 7500kg vehicle travelling at 50mph (80kph) which equates to 1852kj. Maximum width 4000mm, maximum foundation depth required 400mm.

To the amazement of the Security Consultants & Civil Engineers that witnessed the successful PAS 68 impact test, the unit had been installed just 52 hours before impact.

Hydraulically driven. Designed for ease of installation and maintenance. The Terra Shallow Blocker can be interfaced to any access control systems. The top plate's anti skid resistant coating allows safe passage for cyclists.

BENEFITS & FEATURES

Shallow foundation depths of only 400mm required.

Hydraulically operated, 400V

100% duty rating

Instantly reversible

Width up to 4 metres (securing 5.8m apertures)

Impact tested to BSi PAS 68:2010

Concertina Skirt to prevent potential trapping areas.

Wide range of Accessories available.

Control cabinet recommended to be installed within 10 metres of blocker

Top plate is coated in anti skid resistant treatment



Applications: Inner city locations with limited foundation depths that require equipment with a higher level of PAS 68 rating

High Security | Anti Terrorist | Government Institutions | Military Bases | Airports



Terra Shallow Blocker post impact



During manufacture; illustration of the depth.



Foundation:
Only 150mm
required

CIVIL REQUIREMENTS

Based on a 2500mm width blocker L:4600mm x W:3540mm x D:400mm

(Note: Power and control wiring ducts required).

Control Cabinet Foundation L:600mm x W:900mm x D:300mm

ELECTRICAL REQUIREMENTS POWER - Three Phase Supply

*This is subject to a risk assessment to ensure the automatic equipment complies to BS EN 12453

In event of Power Failure

Fail safe (opens to the lowered position)

Fail secure (remains in the raised position)

Option of an automatic Accumulator or manual hand pump is available if the blocker is to be re-raised during power failure.

DUTY CYCLE – 100%

OPERATING SPEED

Typical speeds of 4-6 seconds* depending on configuration. EFO (extra fast operation) in up to 1 second.

OPTIONAL ACCESSORIES - Please see page 36

Accumulator – allows a number of operations in power failure mode

EFO (Extra Fast Operation)

100/200mm Traffic Light Systems

Manual Hand pump

High Security Cabinet

SAFETY - Option of vehicle detector loops and safety photocell beams.

The History of the Terra Blocker: The original Terra Blocker, first tested in 2004 with a 6800kg American truck travelling at 80kph (50mph), then tested in accordance with PAS 68 in 2007, & re tested in 2009 to test the latest technology breakthrough from our on going R&D program.



PAS 68 & K12 L3 Terra Blocker

PAS 68 Terra Blocker MkII 7500kg @ 30mph

V Road Blocker 7500[N2]/48/90:0.0/0.0

Tested dimensions: width 3000mm, lift height 810mm

K12 L3 Terra Blocker: 6800kg American Truck at 80kph (50mph) Zero Penetration

Tested dimensions : width 2500mm, lift height 810mm



Other impact tests:
 PAS 68 Terra Blocker
 7500kg @ 50mph:
 V Road Blocker
 7500[N3]/80/90:4.0/25.0
Tested dimensions :
width 2500mm, lift height 1100mm

PAS 68 Terra Blocker MkII
 7500kg @ 50mph:
 V Road Blocker
 7500[N3]/80/90:13.5/25.1
Tested dimensions :
width 3000mm, lift height 950mm
 Maximum width: 4000mm

Successfully impact tested to the latest BSi PAS 68:2010 specification stopping a 7500kg vehicle travelling at 50mph (80kph) which equates to 1852kj. Maximum width 5000mm.

Hydraulically driven. Designed for ease of installation and maintenance. The Terra Blocker can be interfaced to any access control systems.

BENEFITS & FEATURES.

Hydraulically operated, 400V

100% duty rating

Instantly reversible

Width up to 5 metres (securing 7.4m apertures)

Impact tested to BSi PAS 68:2010 with a range of energies.

Original Terra Blocker impact tested with an 6800kg

American vehicle travelling at 80kph, and remained fully functional after impact.

Wide range of Accessories available

Control cabinet recommended to be installed within 10 metres of blocker

The Road Blocker's Top Plate is fully coated with an anti skid resistant treatment which has been fully tested under laboratory conditions for at least 12 months.

Applications: Sites that require high security PAS 68 barricades

High Security | Anti Terrorist | Government Institutions | Military Bases | Airports

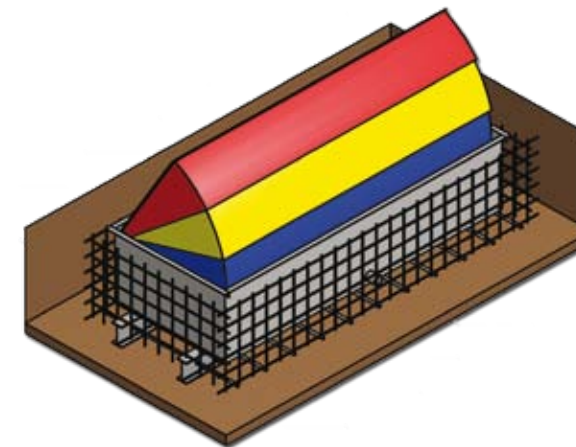

First Terra Blocker impact test in 2004. K12 L3 test with a 6800kg American truck travelling at 80kph (50mph). Fully functional after impact.

In event of Power Failure

Fail safe (opens to the lowered position)

Fail secure (remains in the raised position)

Option of an automatic Accumulator or a manual hand pump is available if the blocker is to be re-raised during power failure.

DUTY CYCLE – 100%

OPERATING SPEED

Typical speeds of 4-6 seconds* depending on configuration. EFO (extra fast operation) In up to 1 second.

OPTIONAL ACCESSORIES - Please see page 36
 Accumulator – allows a number of operations in power failure mode

EFO (Extra Fast Operation)

100/200mm Traffic Light Systems

Manual Hand pump

High Security Cabinet



SAFETY - Option of vehicle detector loops and safety photocell beams.

CIVIL REQUIREMENTS

Based on a 3000mm width blocker

L:2200mm x W:4000mm x D:935mm

(Note: Power and control wiring ducts required).

Control Cabinet Foundation

L:600mm x W:900mm x D:300mm

ELECTRICAL REQUIREMENTS POWER

Three Phase Supply

*This is subject to a risk assessment to ensure the automatic equipment complies to BS EN 12453



Hydraulic control cabinets for Terra Blockers and Active Terra Bollards are recommended to be installed within 10 metres of the unit, within site in a secure location.



Left: Hydraulic Control Cabinet installed next to Terra Blocker within the site perimeter. Above: Terra Bollards Hydraulic Control Cabinet installed securely within building.



Left: Hydraulic Control Cabinet installed next to Terra Blocker within the site perimeter. Above: Terra Bollards Hydraulic Control Cabinet installed securely within building.



Terra Blocker & Active Terra Bollards
Optional Accessories - housed within control cabinet:

Options of an automatic Accumulator or manual hand pump are available if the Blocker or Bollard is to be re-raised during power failure.

EFO - Extra Fast Operating Speeds.

Vandal resistant traffic light cages

Left: Multiple Terra Bollards Control Cabinet

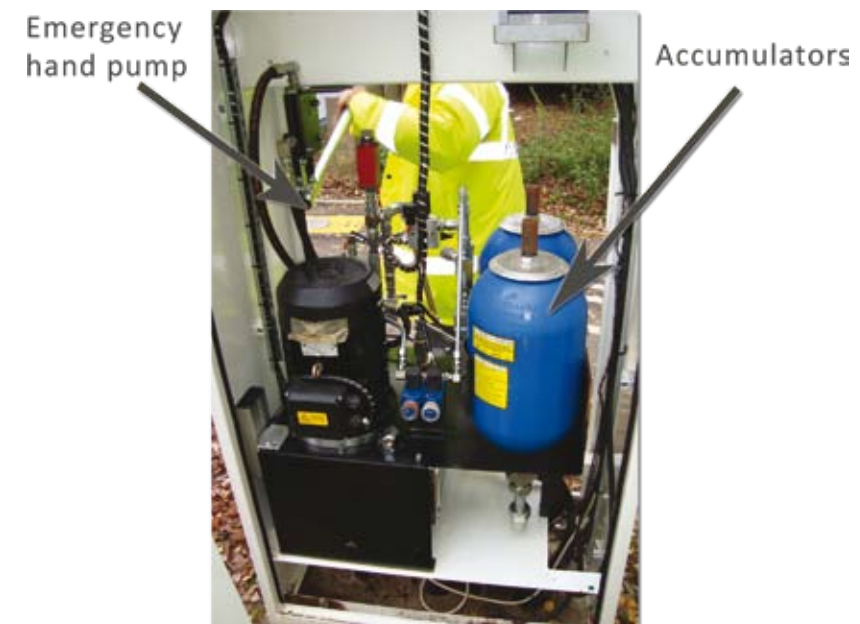

The PAS 68 Rising/Active Terra Bollards from Frontier Pitts is a counter terrorist bollard, hydraulically driven for reliability & strength.



PAS 68 Rising Terra Blocker

V Bollards 7500[N2]/80/90:5.0/9.2

Tested dimensions : lift height 900mm



Left - Terra Bollard with Special painted finish

Successfully impact tested to BSi PAS 68 specification stopping a 7500kg N2 vehicle travelling at 50mph (80kph) which equates to 1852kJ.

Lift height 900mm. BSi PAS 68 Bollards are required to be installed at 1200mm between upright bollard faces to meet BSi PAS 69:2006 guidelines.

Stainless steel finish as standard.
Painted powder coating optional.
Matching Static Terra Saturn Bollards are available.

Hydraulically driven. Designed for ease of installation and maintenance.

BENEFITS & FEATURES

- Fully functional after impact test.
- Hydraulically operated 400V
- 100% duty rating, instantly reversible
- Impact tested to BSi PAS 68
- Wide range of Accessories available.
- Control cabinet recommended to be installed within 10 metres of bollard.
- Further bespoke systems available.



Applications: Sites that require a PAS 68 restriction on vehicle access whilst allowing free passage by pedestrians

High Security | Anti Terrorist | Government Institutions
Military Bases | Embassies | Airports |



In event of Power Failure
Fail safe (opens to the lowered position)
Fail secure (remains in the raised position)

Option of an automatic Accumulator or a manual hand pump is available if the bollard is to be re-raised during power failure.

DUTY CYCLE – 100%

OPERATING SPEED

Typical speeds of 4-10 seconds* depending on configuration. EFO (extra fast operation) in up to 3 second.

OPTIONAL ACCESSORIES - Please see page 36
Accumulator – allows a number of operations in power failure mode

- EFO (Extra Fast Operation)
- 100/200mm Traffic Light System
- Manual Hand pump
- High Security Cabinet

SAFETY - Option of vehicle detector loops and safety photocell beams.

CIVIL REQUIREMENTS

L:2080mm W:2100mm x D:1450mm
(Note: Power and control wiring ducts required).

Control Cabinet Foundation
L:600mm x W:900mm x D:300mm

ELECTRICAL REQUIREMENTS POWER
Three Phase Supply

*This is subject to a risk assessment to ensure the automatic equipment complies to BS EN 12453



Planets Range of PAS 68 Static Terra Bollards Shallow & Removable options available

A portfolio of Static/Fixed Bollards successfully impact tested to the latest BSi PAS 68:2010 specification stopping various energies.

Applications: Sites that require a PAS 68 restriction on vehicle access whilst allowing free passage by pedestrians

High Security | Anti Terrorist | Government Institutions
Military Bases | Embassies | Airports |



Terra Jupiter Bollards - 7500kg @ 50mph (1852kj)

Classification Codes:
V/7500[N2]/80/90:1.0/2|1.2
V/7500[N3]/80/90:10.5/1|1.1

Embedment - 500mm
Height above ground - 1050mm
Diameter - 273mmø
Finish - Painted Powder Coating
Optional - Stainless Steel Finish

Removable Terra Jupiter Bollards - 7500kg @ 50mph (1852kj)

Classification Codes:
V/7500[N3]/80/90:10.5/1|1.1

Embedment - 750mm
Height above ground - 1050mm
Diameter - 273mmø
Finish - Painted Powder Coating
Optional - Stainless Steel Finish



Terra Venus Bollards - 7500kg @ 30mph (667kj)

Classification Codes:
V/7500[N2]/48/90:0.0/0.0

Embedment - 500mm
Height above ground - 1000mm
Diameter - 219mmø
Finish - Painted Powder Coating
Optional - Stainless Steel Finish

Shallow Depth Terra Venus Bollards - 7500kg @ 30mph (667kj)

Classification Codes:
V/7500[N2]/48/90:3.3/0.0

Embedment - 300mm
Height above ground - 1000mm
Diameter - 219mmø
Finish - Painted Powder Coating
Optional - Stainless Steel Finish

Removable Terra Venus Bollards - 7500kg @ 30mph (667kj)

Classification Codes:
V/7500[N2]/48/90:0.0/0.0

Embedment - 500mm
Height above ground - 1050mm
Diameter - 273mmø
Finish - Painted Powder Coating
Optional - Stainless Steel Finish



PAS 68 Static Terra Saturn Bollards

The Static Terra Saturn Bollard is designed to match the PAS 68 Rising Terra Bollards
Height above ground : 900mm



The Static Terra Saturn Bollard match the Rising Terra Bollards and create a perimeter protection line.

Installation in accordance with the latest BSi PAS 69:2006 specification; bollards should be spaced at 1200mm between upright bollard faces.

Painted powder coating finish as standard.
Stainless steel finish available on request.

CIVIL REQUIREMENTS

W: 900mm x D: 900mm x L: 900mm



Right: Static Terra Saturn Bollards installed alongside Rising Bollards, providing perimeter protection from unauthorised vehicles whilst allowing pedestrian access

The Static PAS 68 Terra Pyramids Bollards with SMT (Shallow Mount Technology) from Frontier Pitts.
Applications: Ideal for inner city sites where foundation depths are limited.

PAS 68 SMT Terra Pyramids Bollards

V Bollards 7500[N2]/48/90:1.71/0.0 Energy - 667kJ
Tested dimensions : height above ground 1050mm



Height above ground 1050mm
Terra Pyramid Bollards impact tested to the latest BSi PAS 68:2010 specification
Bollards are required to be installed at a distance of 1200mm between upright bollard faces to meet the latest BSi PAS 69:2006 guidelines.

Designed for easy installation

Stainless steel finish as standard

BENEFITS & FEATURES

Shallow Mount Technology.
Foundation depths of only 120mm required.
Impact tested to BSi PAS 68 with a range of energies



Frontier Pitts Ltd has become the first company to achieve LPS 1175 Issue 6 for the full height Terra Diamond Turnstile Grade 3 and Grade 4.



LPS 1175 Terra Diamond Turnstile

LPS 1175: Issue 6.1 Security Rating 3 & 4

Applications: High Security Pedestrian Control Access

Security Rating 3 - Certificate Number 1059a/01

Security Rating 4 - Certificate Number 1059a/02



Approved for UK Government Use
(please contact CPNI)



Approved for UK Government Use,
for details contact CPNI

Certified to LPS 1175: Issue 6.1
Security Rating 3 & 4
Certificate Number
1059a/01 & 1059a/02



The Terra Diamond Turnstiles successfully resisted an intensive attack test programme in accordance with LPS 1175: Issue 6.1. These involved a series of attack tests each lasting at least 10 minutes using a wide array of hand tools and battery powered tools.

The Terra Diamond Turnstiles are the only turnstiles currently on the market that are approved to LPS 1175 Security Ratings 3 and 4.

*correct at time of print

Design Features

- Heavy duty, high security turnstile
- Robust steel 90 degree rotor
- In filled rotor arms prevent climbing
- Allows only single file authorised access
- Metal reinforced high security lid
- Painted to clients choice of BS/RAL colour
- AC Interface and microprocessor control board
- Status indicator with red & green light
- Heavy duty, vandal resistant head mechanism
- Anti return solenoid lock
- Fail secure – turnstile will remain secure during power failure.

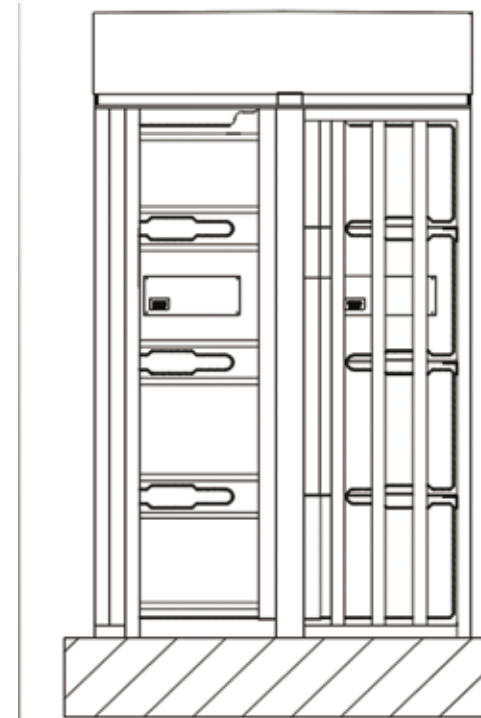

VIEW FROM SECURE SIDE

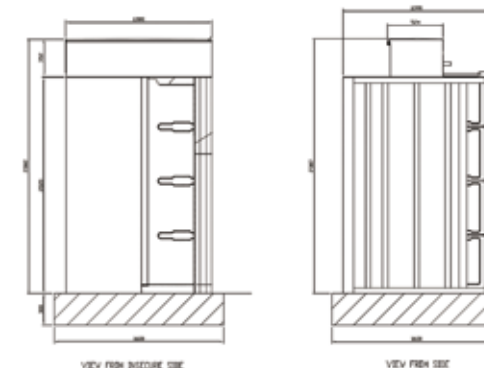

VIEW FROM INSECURE SIDE

VIEW FROM SIDE

On receipt of a signal from a push-button, card reader etc., the turnstile will release the rotor, then closes and relocks. The park assembly has a positive action lock which prevents the arm rotating in reverse after 60°

Standard internal height: 2020mm
Standard gateleaf width: 500mm
Colour: Any colour in the RAL range

CONSTRUCTION

Cage - Fully welded steel cage backed with high security sheet steel forms a short walkway. Columns are used to mount card readers etc

Canopy - Metal canopy with anti-drip guttering, with reinforced high security lid which lifts off for access

Rotor - 90° High-strength sheet steel blades. (Grade 4 has additional reinforcing for increased resistance to attack)

CIVIL REQUIREMENTS

L:1260mm x W:1600mm x D:300mm
(Note: Power and control wiring ducts to be incorporated into foundations)

ELECTRICAL REQUIREMENTS POWER

10 Amp, 3 wire, 240v 50hz - Single phase supply
*This is subject to a risk assessment to ensure the automatic equipment complies to BS EN 12453

FRONTIER PITTS LTD OFFICES

UK HEAD OFFICE

Frontier Pitts Ltd
Crompton House, Crompton Way,
Manor Royal Industrial Estate,
Crawley, West Sussex RH10 9QZ. UK

Tel: +44 1293 548301 Fax: +44 1293 560650
Sales Tel: + 44 1293 422800
Email: sales@frontierpitts.com
Website: www.frontierpitts.com

EUROPEAN OFFICE

Frontier Pitts France
Immeuble Alliance
226 rue Georges Besse
30000 Nimes
FRANCE

Tel: 00 33 466 04 29 69 Fax: 00 33 466 04 29 70
Email: info@frontier-pitts.fr
Website: www.frontier-pitts.fr

HONG KONG OFFICE

Frontier Pitts Ltd
c/o Uniforce Security Systems Ltd
Flat C-D, 3/F, Howard Factory Building,
66 Tsun Yip Street, Kwun Tong,
Kowloon, Hong Kong
Tel: + 852 2793 3800 Fax: +852 2763 4074
Email: sales@frontierpitts.com.hk

ASIAN OFFICE

Frontier Pitts Ltd
c/o Uniforce Electronic Engineering (Dongguan) Ltd
Shop 2-13, Li Jing Xin Yuan, Tian Er Hu Road,
Changping, Dongguan, Guangdong Province, PRC.
China 523560
Tel: +86 769 8391 8220
Fax: +86 769 8391 8606
Website: sales@frontierpitts.com.hk

