

Original instructions

## PA3200C

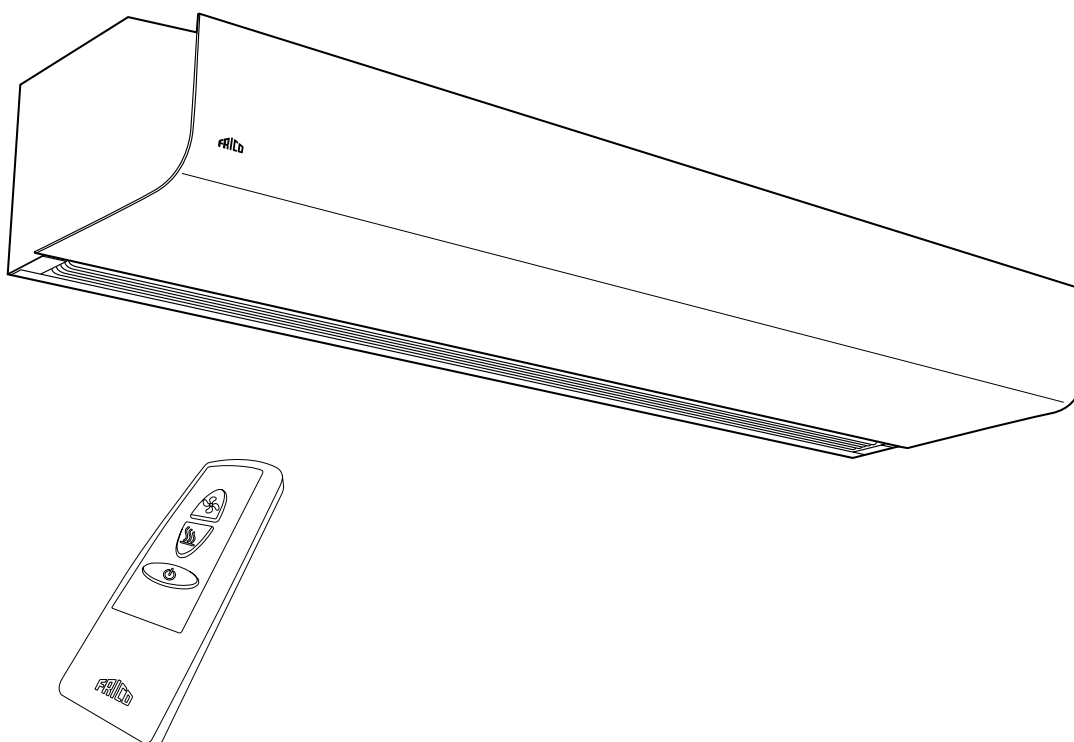

SE .... 16

GB ... 23

NO ... 29

DE ... 36

ES ... 43

FR ... 50

IT ... 57

NL ... 64

PL ... 71

RU ... 78

- SE** Introduktionssidorna består huvudsakligen av bilder. För översättning av de engelska texter som används, se respektive språksidor.
- GB** The introduction pages consist mainly of pictures. For translation of the English texts used, see the respective language pages.
- NO** Introduksjonssidene består hovedsakelig av bilder. For oversettelse av de engelske tekstene, se de respektive språksidene
- FR** Les pages de présentation contiennent principalement des images. Pour la traduction des textes en anglais, consultez la page correspondante à la langue souhaitée.
- DE** Die Einleitungsseiten bestehen hauptsächlich aus Bildern. Für die Übersetzung der verwendeten Texte in englischer Sprache, siehe die entsprechenden Sprachseiten.
- ES** Las páginas introductorias contienen básicamente imágenes. Consulte la traducción de los textos en inglés que las acompañan en las páginas del idioma correspondiente.
- NL** De inleidende pagina's bevatten hoofdzakelijk afbeeldingen. Voor een vertaling van de gebruikte Engelse teksten, zie de pagina's van de resp. taal.
- IT** Le pagine introduttive contengono prevalentemente immagini. Per le traduzioni dei testi scritti in inglese, vedere le pagine nelle diverse lingue.
- PL** Początkowe strony zawierają głównie rysunki. Tłumaczenie wykorzystanych tekstów angielskich znajduje się na odpowiednich stronach językowych.
- RU** Страницы в начале Инструкции состоят в основном из рисунков, схем и таблиц. Перевод встречающегося там текста приведен в разделе RU.

# PA3200C

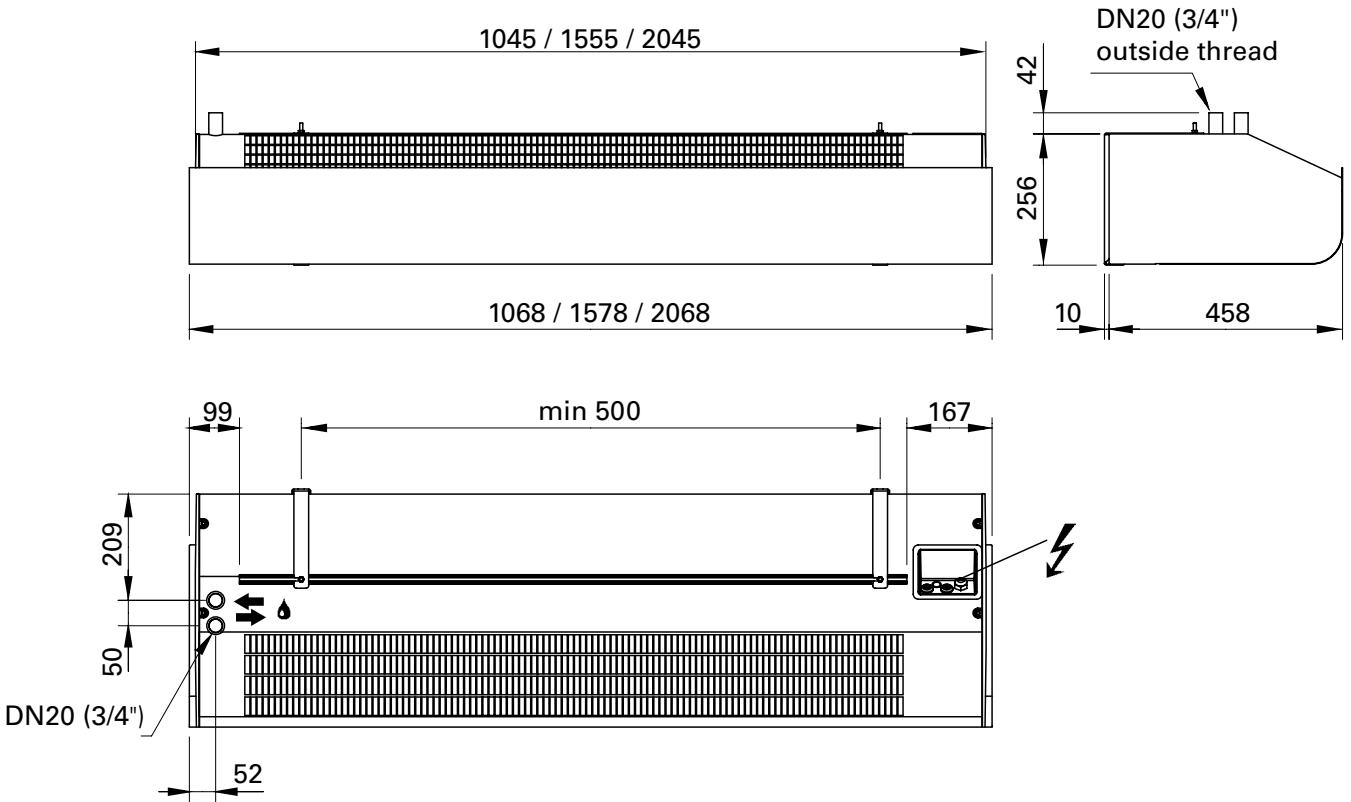

**L = 2 m**

**A / W**

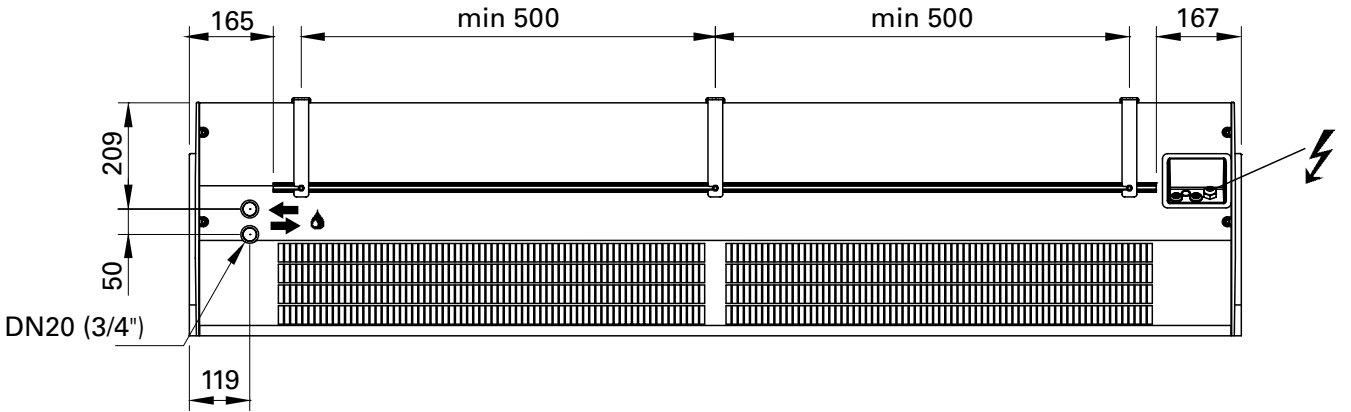

**E**

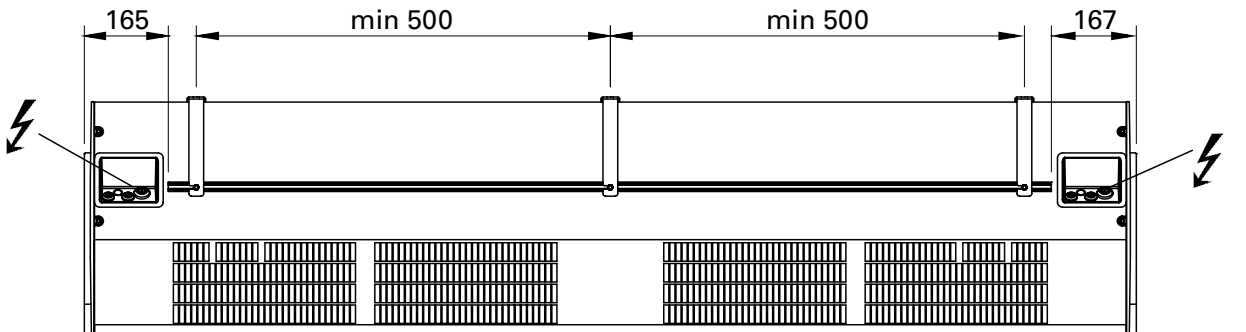

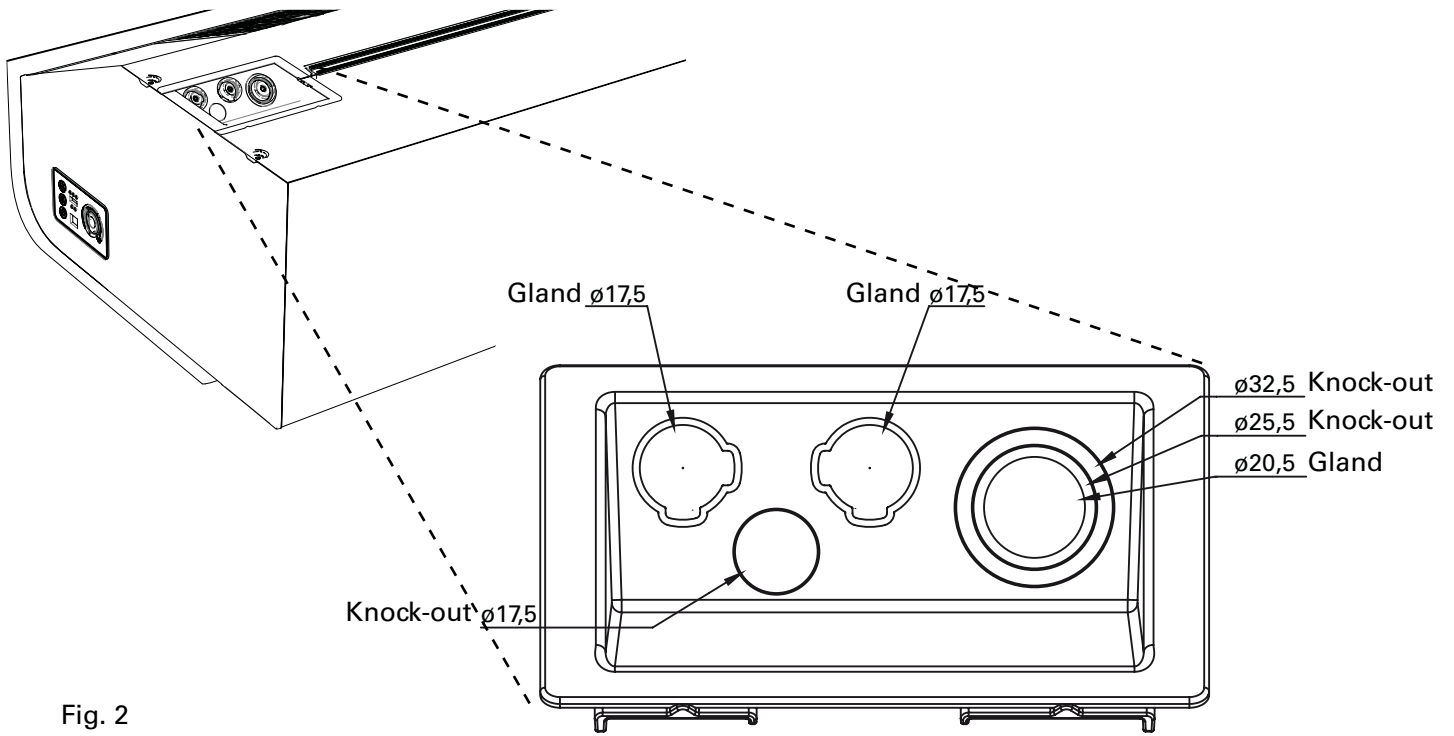

Fig. 2

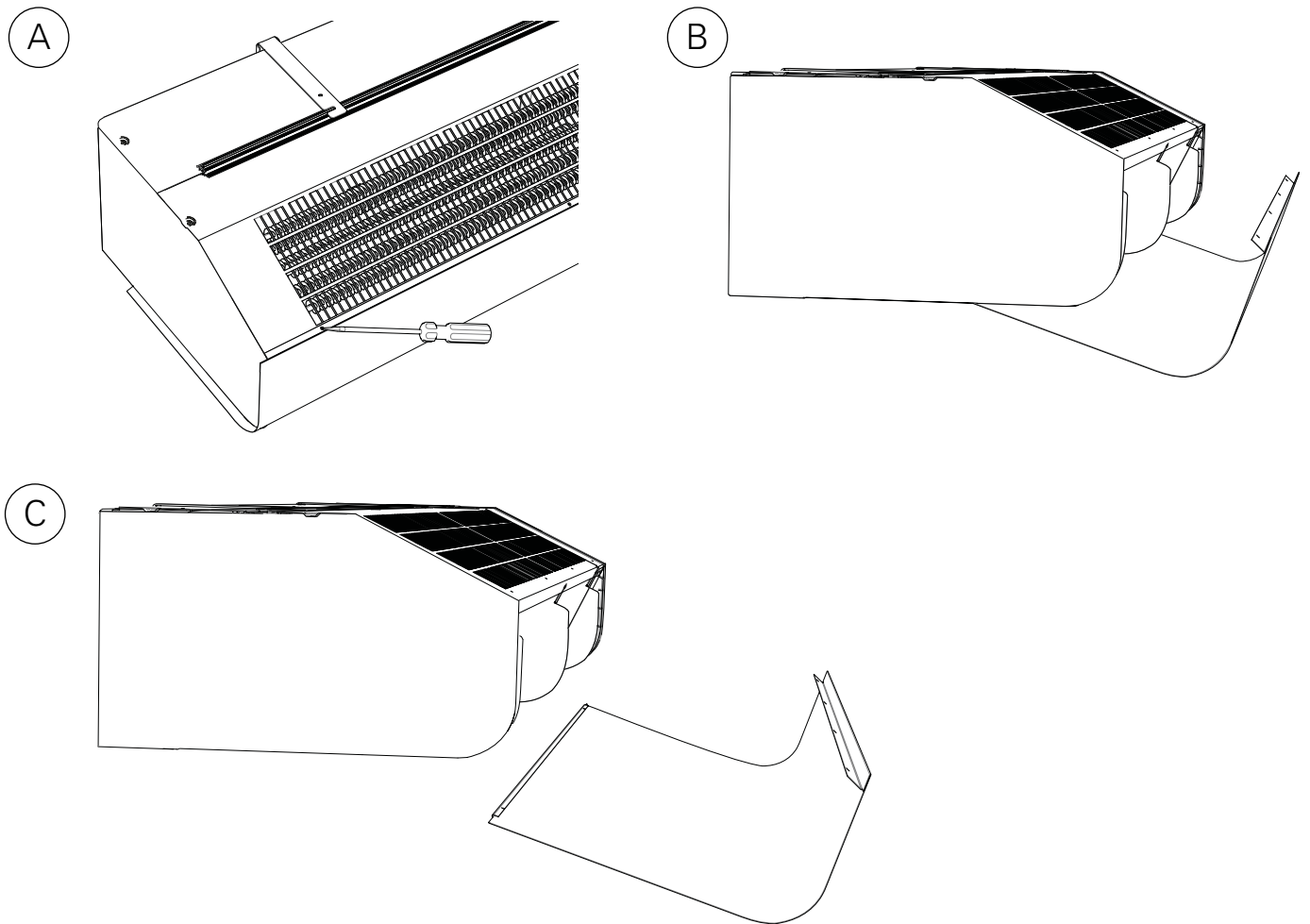

Fig. 3: Open the unit.

Minimum distance

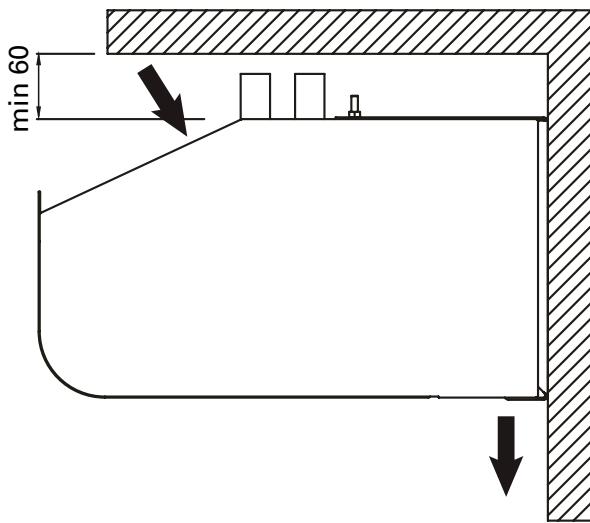

Fig. 4

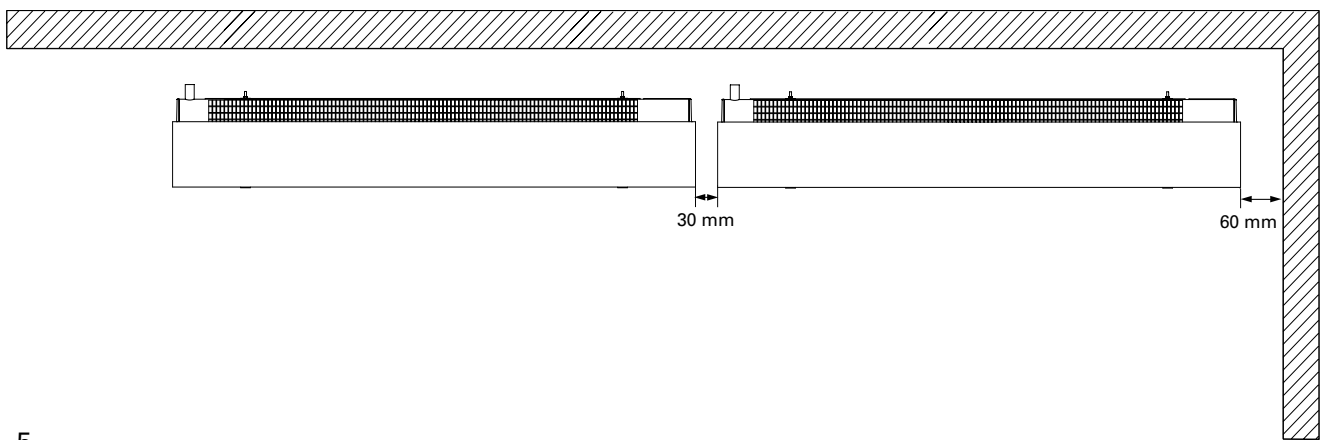

Fig. 5

Mounting with wall brackets

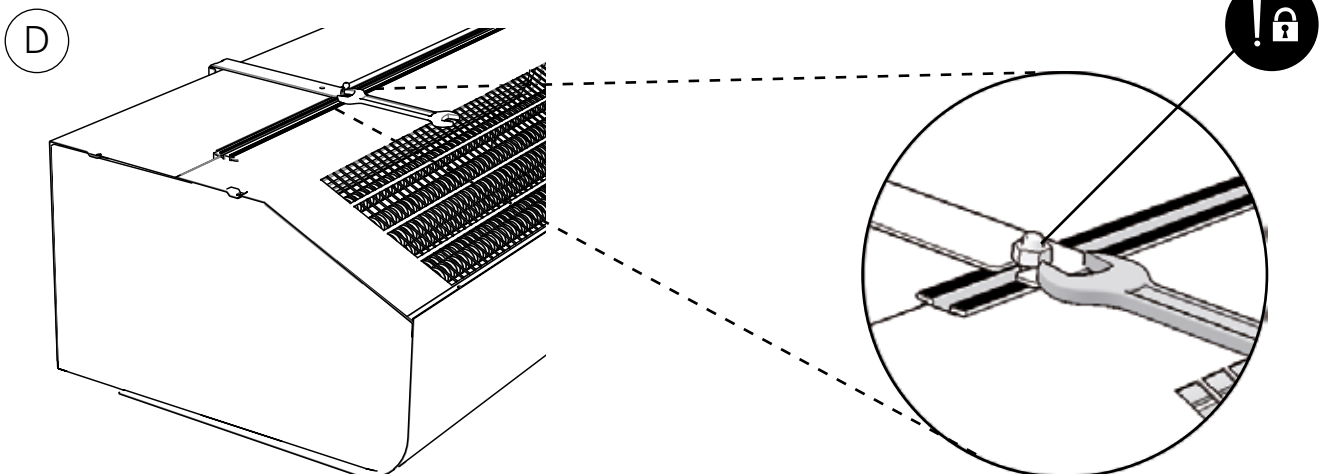
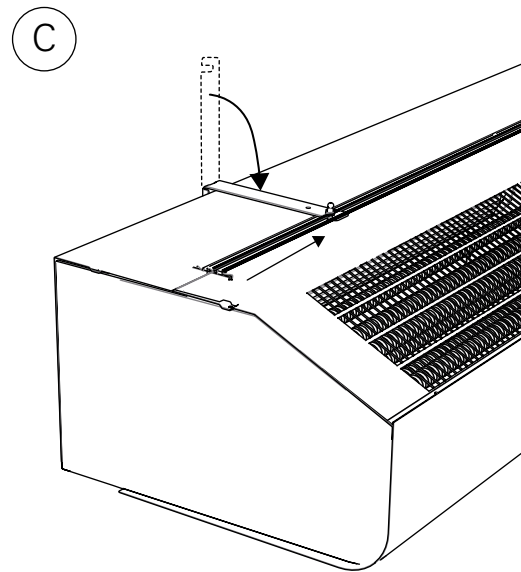
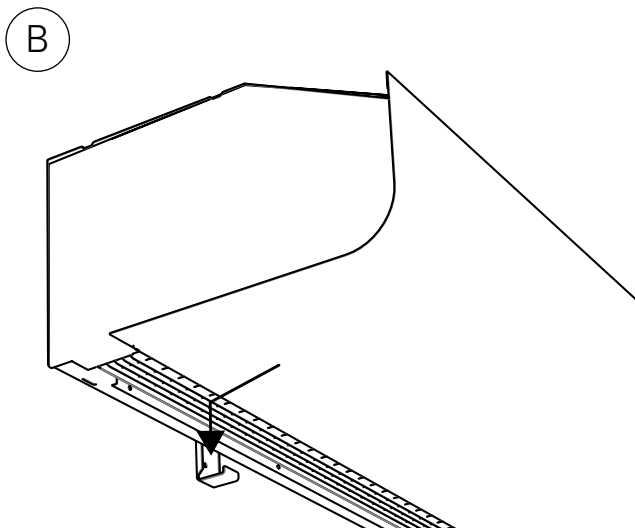
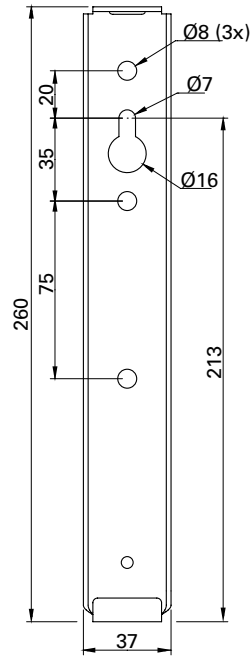
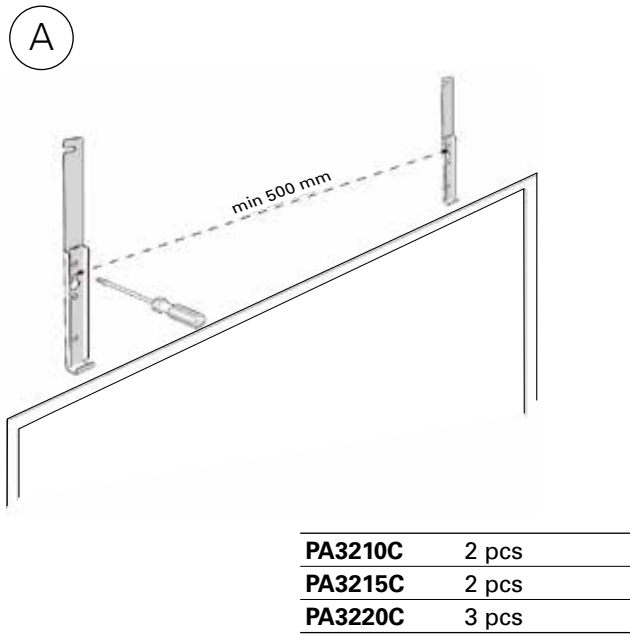
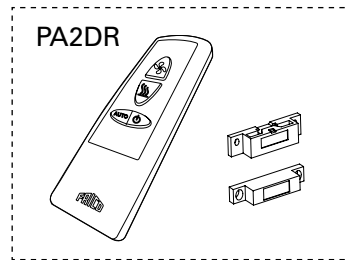
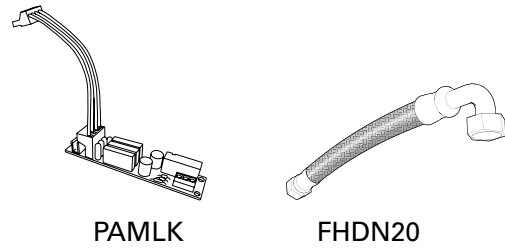
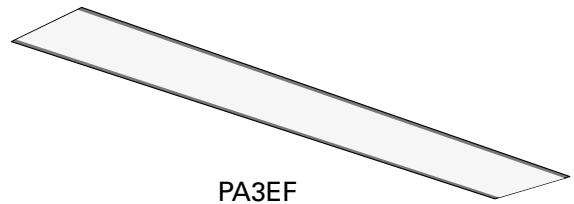
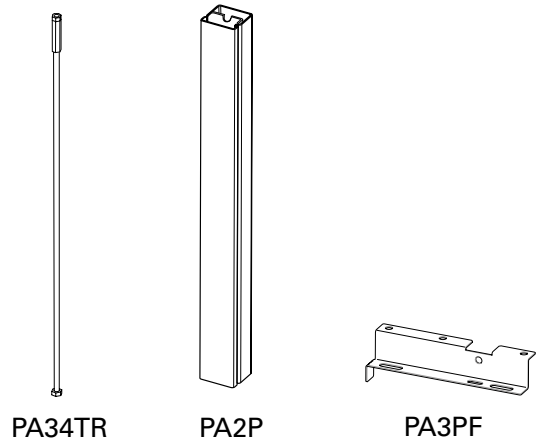

Fig. 6: Mounting with wall brackets

Accessories

<b>PA34TR15</b>	PA3210C, PA3215C, 1 m
<b>PA34TR20</b>	PA3220C, 1 m
<b>PA2P15</b>	PA3210C, PA3215C, 1 m
<b>PA2P20</b>	PA3220C, 1 m
<b>PA3PF15</b>	PA3210C, PA3215C
<b>PA3PF20</b>	PA3220C
<b>PAMLK</b>	PA3200C
<b>PA3EF10</b>	PA3210C W
<b>PA3EF15</b>	PA3215C W
<b>PA3EF20</b>	PA3220C W
<b>FHDN20</b>	PA3200C W



PA2DR



<b>VOT15</b>	DN15
<b>VOT20</b>	DN20
<b>VOT25</b>	DN25
<b>VOS15LF</b>	DN15
<b>VOS15NF</b>	DN15
<b>VOS20</b>	DN20
<b>VOS25</b>	DN25

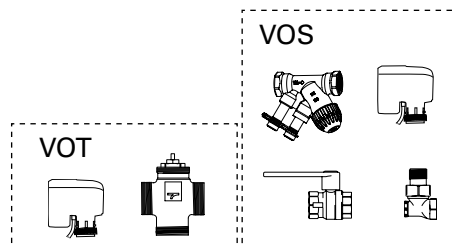

PA3210CA / PA3215CA / PA3220CA

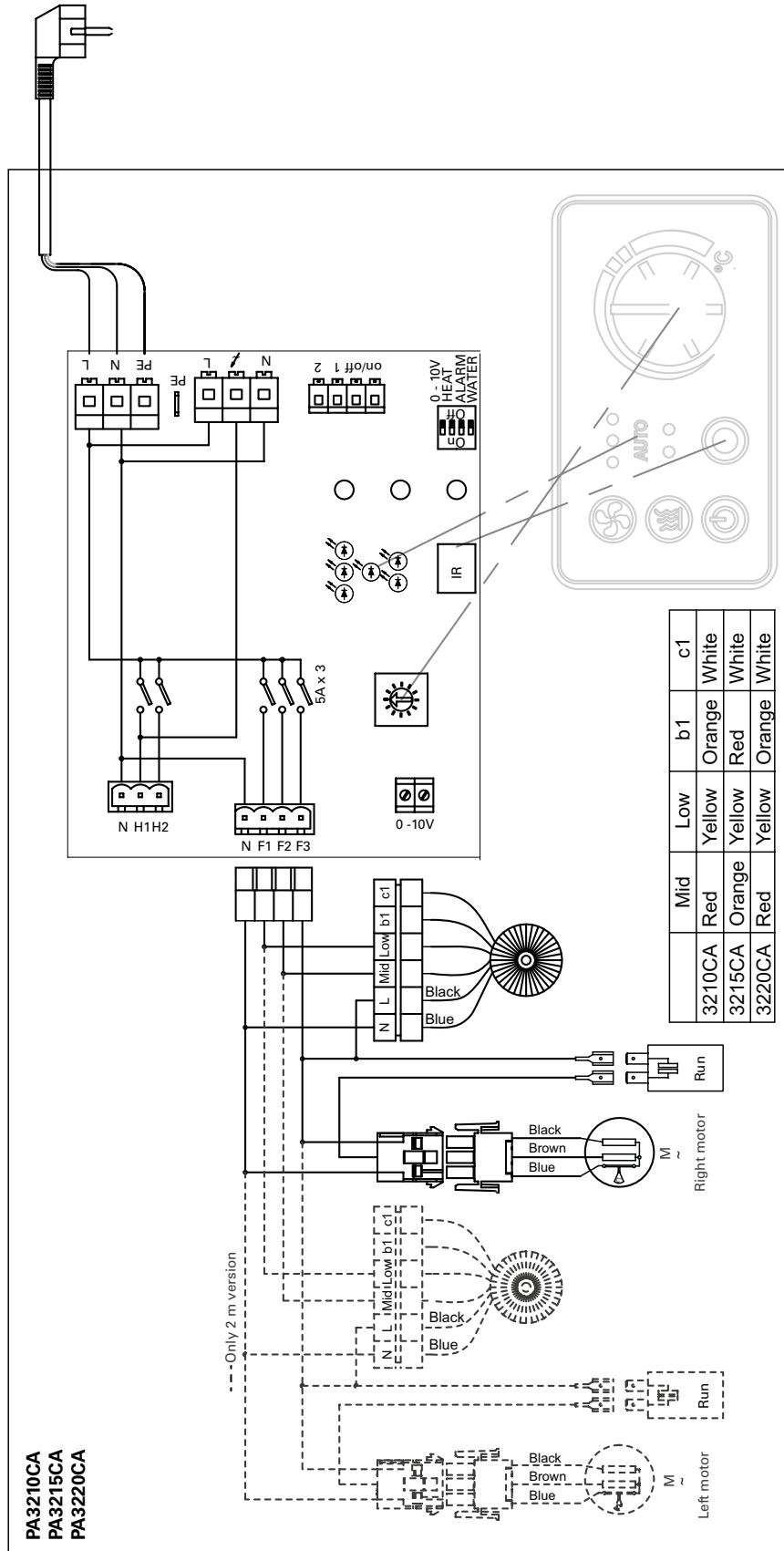

PA3210CE8 / PA3215CE12 / PA3220CE16

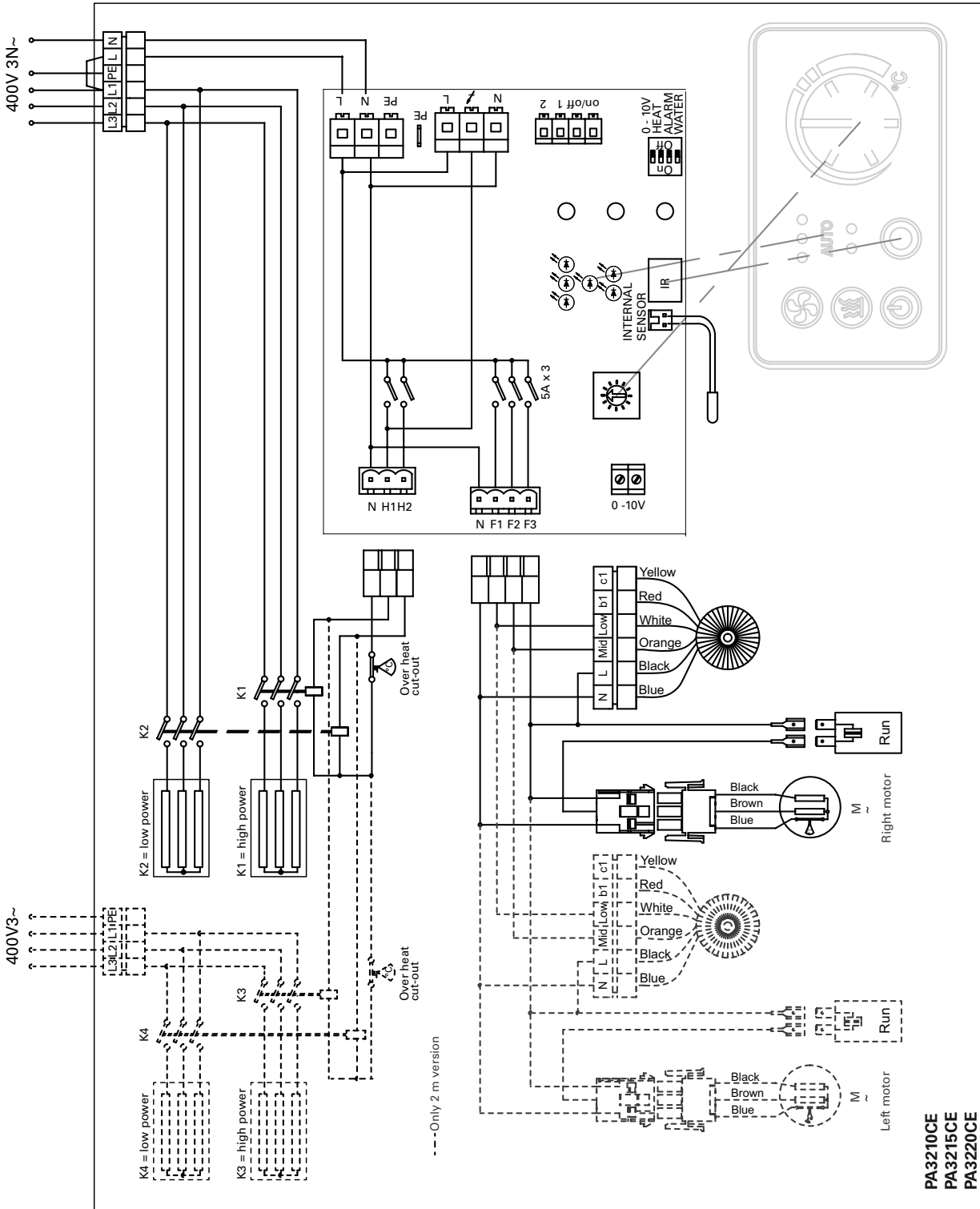

PA3210CE08YD / PA3215CE12YD / PA3220CE16YD 230V3~

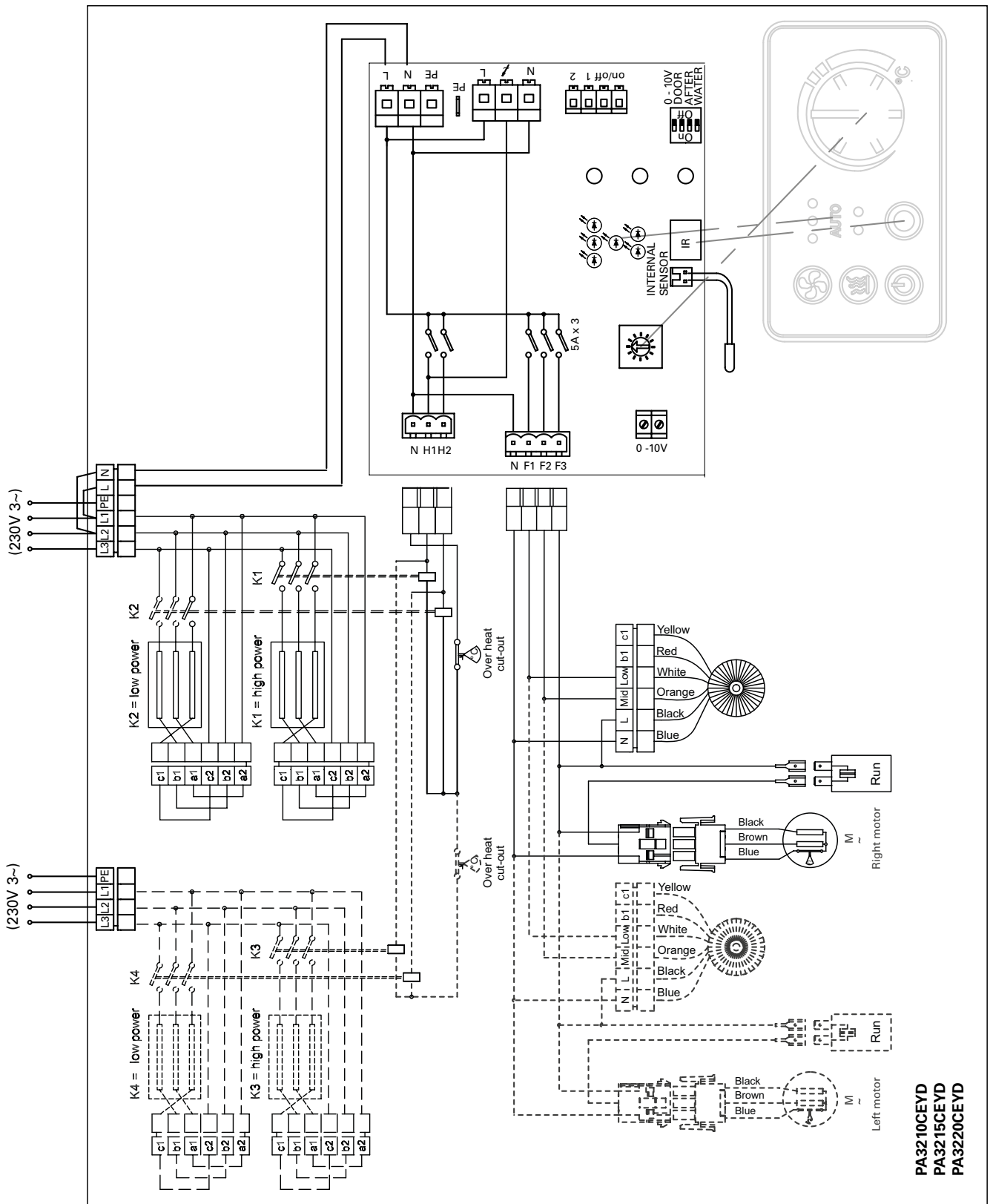

PA3210CE08YD / PA3215CE12YD / PA3220CE16YD 400V3~

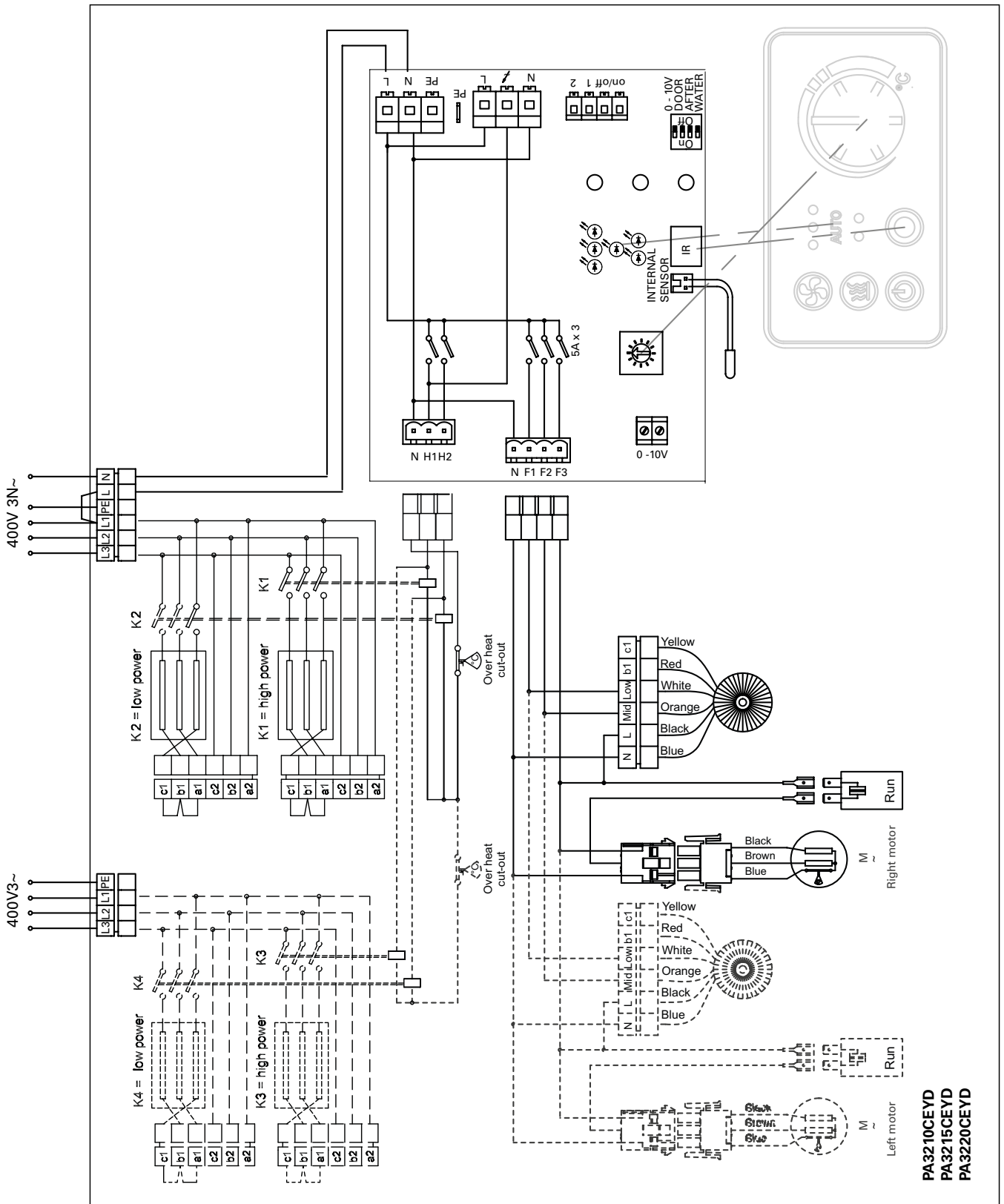

PA3210CW / PA3215CW / PA3220CW

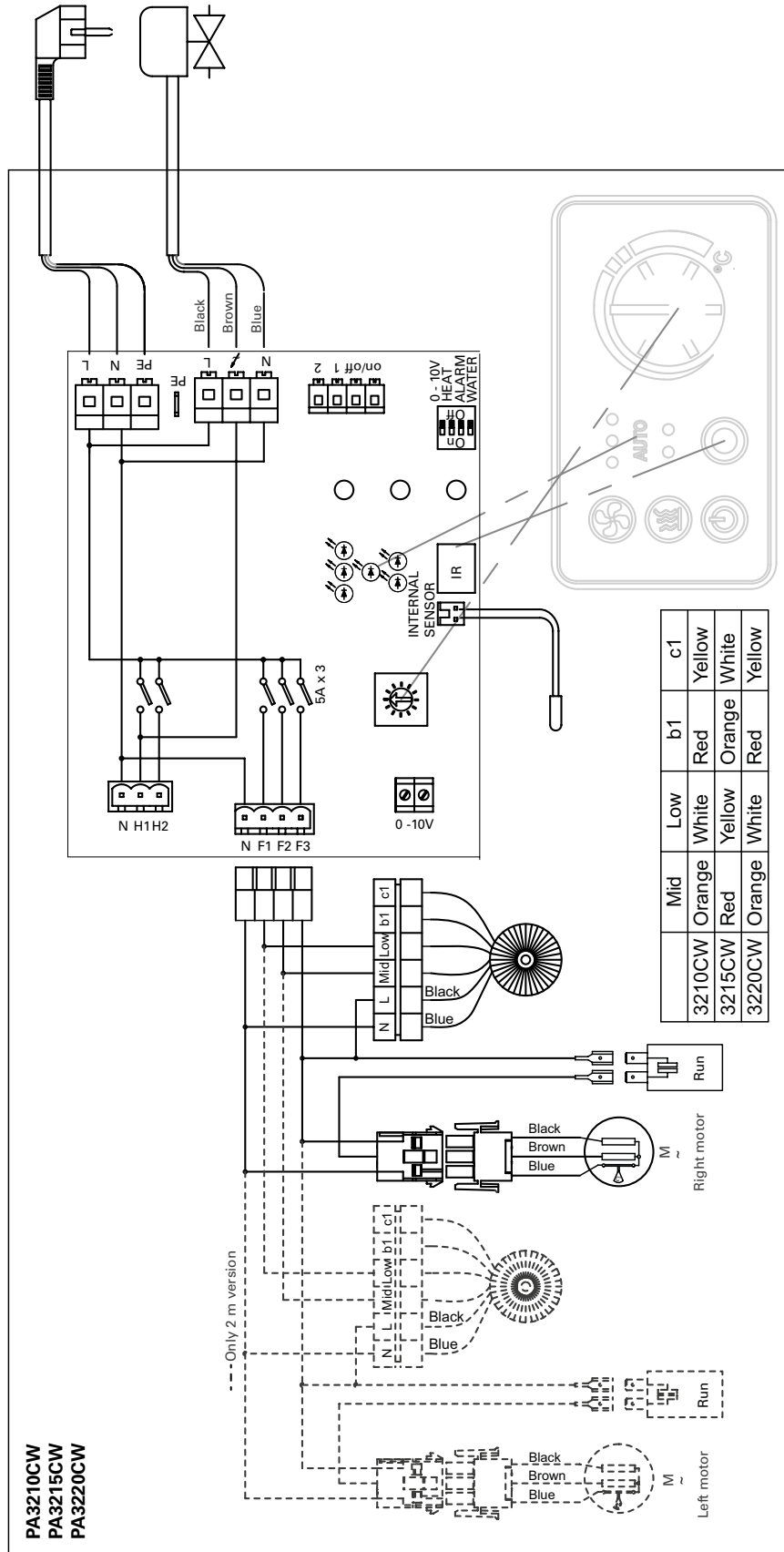

PAMLK

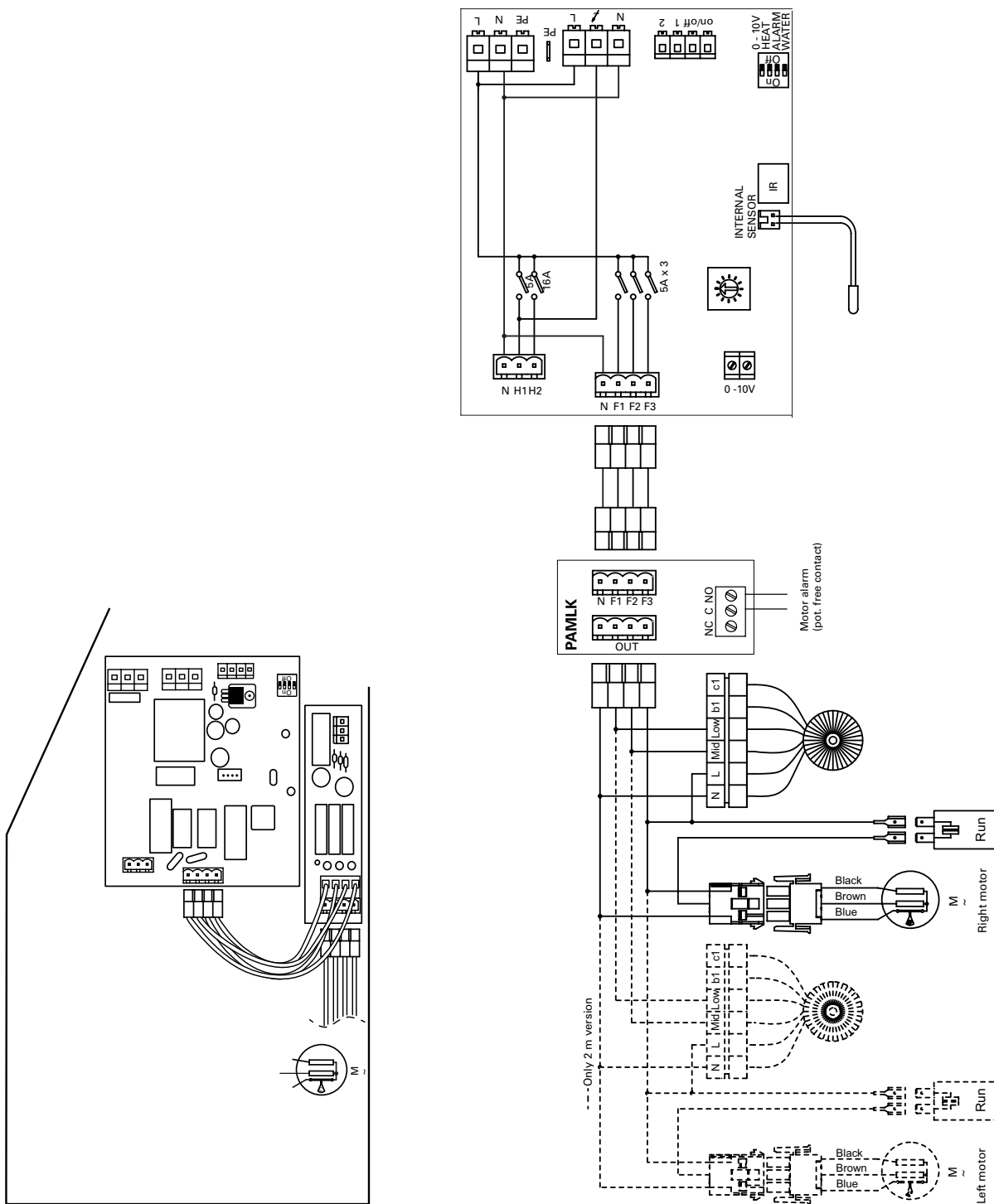

## PA3200C

### ✿ Ambient, no heat - PA3200C A

Type	Output [kW]	Airflow* <sup>1</sup> [m <sup>3</sup> /h]	Sound level* <sup>2</sup> [dB(A)]	Voltage motor [V]	Amperage motor [A]	Length [mm]	Weight [kg]
PA3210CA	0	1100/1750	46/57	230V~	0,7	1068	22
PA3215CA	0	1700/2750	46/59	230V~	1,0	1578	32
PA3220CA	0	2300/3500	50/60	230V~	1,3	2068	43

### ⚡ Electrical heat - PA3200C E

Type	Output step [kW]	Airflow* <sup>1</sup> [m <sup>3</sup> /h]	$\Delta t$ * <sup>3</sup> [°C]	Sound level* <sup>2</sup> [dB(A)]	Voltage motor [V]	Amperage motor [A]	Voltage [V] Amperage [A] (heat)	Length [mm]	Weight [kg]
PA3210CE08	5/8	1100/1750	22/13	46/57	230V~	0,65	400V3~/11,5	1068	26
PA3215CE12	8/12	1700/2750	21/13	46/59	230V~	1,0	400V3~/17,3	1578	37
PA3220CE16	10/16	2300/3500	22/13	50/60	230V~	1,3	400V3~/23,1	2068	51

### ⚡ Electrical heat 230V3~ - PA3200C E

Type	Output step [kW]	Airflow* <sup>1</sup> [m <sup>3</sup> /h]	$\Delta t$ * <sup>3</sup> [°C]	Sound level* <sup>2</sup> [dB(A)]	Voltage motor [V]	Amperage motor [A]	Voltage heat [V]	Amperage heat [A]	Length [mm]	Weight [kg]
PA3210CE08YD	5/8	1100/1750	22/13	46/57	230V~	0,65	230V3~/400V3~	20,1/11,5	1068	26
PA3215CE12YD	8/12	1700/2750	21/13	46/59	230V~	1,0	230V3~/400V3~	30,1/17,3	1578	37
PA3220CE16YD	10/16	2300/3500	22/13	50/60	230V~	1,3	230V3~/400V3~	40,2/23,1	2068	51

### 💧 Water heat - PA3200C W

Type	Output* <sup>4</sup> [kW]	Airflow* <sup>1</sup> [m <sup>3</sup> /h]	$\Delta t$ * <sup>3,4</sup> [°C]	Water volume [l]	Sound level* <sup>2</sup> [dB(A)]	Voltage motor [V]	Amperage motor [A]	Length [mm]	Weight [kg]
PA3210CW	8	1050/1700	16/14	1,3	45/55	230V~	0,65	1068	26
PA3215CW	14	1850/2700	17/15	2,1	46/57	230V~	0,7	1578	36
PA3220CW	18	2200/3300	18/16	2,7	49/58	230V~	1,3	2068	48

\*<sup>1</sup>) Lowest/highest airflow of totally 3 fan steps.

\*<sup>2</sup>) Conditions: Distance to the unit 5 metres. Directional factor: 2. Equivalent absorption area: 200 m<sup>2</sup>. At lowest/highest airflow.

\*<sup>3</sup>)  $\Delta t$  = temperature rise of passing air at maximum heat output and lowest/highest airflow.

\*<sup>4</sup>) Applicable at water temperature 60/40 °C, air temperature, in +18 °C.

Protection class for units with electrical heating: IP20.

Protection class for units without heating and units with water heating: IP21.

CE compliant.

## Output charts water PA3200C

			Supply water temperature: 80 °C Room temperature: +18 °C Outlet air temperature: +35 °C*1				Water temperature: 80/60 °C Room temperature: +18 °C			
Type	Fan position	Airflow [m³/h]	Output [kW]	Return water temp. [°C]	Water flow [l/s]	Pressure drop [kPa]	Output *2 [kW]	Outlet air temp. [°C]	Water flow [l/s]	Pressure drop [kPa]
PA3210CW	max	1700	9,8	42	0,06	1,4	14,6	43	0,18	8,5
	min	1050	6,2	38	0,04	0,5	10,6	48	0,13	4,8
PA3215CW	max	2700	15,6	38	0,09	2,0	24,7	45	0,30	16,8
	min	1850	10,5	34	0,06	0,9	19,2	49	0,23	10,6
PA3220CW	max	3300	18,6	36	0,10	1,9	31,2	46	0,38	19,0
	min	2200	12,6	34	0,07	0,9	23,7	50	0,29	11,5

			Supply water temperature: 70 °C Room temperature: +18 °C Outlet air temperature: +35 °C*1				Water temperature: 70/50 °C Room temperature: +18 °C			
Type	Fan position	Airflow [m³/h]	Output [kW]	Return water temp. [°C]	Water flow [l/s]	Pressure drop [kPa]	Output *2 [kW]	Outlet air temp. [°C]	Water flow [l/s]	Pressure drop [kPa]
PA3210CW	max	1700	9,7	44	0,09	2,7	11,3	38	0,14	5,5
	min	1050	6,1	39	0,05	0,9	8,3	41	0,10	3,2
PA3215CW	max	2700	15,6	41	0,13	3,9	19,4	39	0,24	11,1
	min	1850	11,0	38	0,08	1,7	15,0	42	0,18	7,0
PA3220CW	max	3300	18,9	39	0,15	3,7	24,4	40	0,30	12,5
	min	2200	12,9	36	0,09	1,6	18,6	43	0,23	7,6

			Supply water temperature: 60 °C Room temperature: +18 °C Outlet air temperature: +35 °C*1				Water temperature: 60/40 °C Room temperature: +18 °C			
Type	Fan position	Airflow [m³/h]	Output [kW]	Return water temp. [°C]	Water flow [l/s]	Pressure drop [kPa]	Output *2 [kW]	Outlet air temp. [°C]	Water flow [l/s]	Pressure drop [kPa]
PA3210CW	max	1700	10,0	48	0,19	10,5	8,0	32	0,10	3,1
	min	1050	6,1	41	0,08	2,1	5,8	34	0,07	1,8
PA3215CW	max	2700	16,0	45	0,26	13,4	13,9	33	0,17	6,3
	min	1850	10,8	40	0,13	4,0	10,8	35	0,13	4,0
PA3220CW	max	3300	18,9	42	0,26	10,2	17,6	34	0,21	7,1
	min	2200	12,9	39	0,15	3,6	13,4	36	0,16	4,4

			Supply water temperature: 55 °C Room temperature: +18 °C Outlet air temperature: +35 °C*1				Water temperature: 55/35 °C Room temperature: +18 °C			
Type	Fan position	Airflow [m³/h]	Output [kW]	Return water temp. [°C]	Water flow [l/s]	Pressure drop [kPa]	Output *2 [kW]	Outlet air temp. [°C]	Water flow [l/s]	Pressure drop [kPa]
PA3210CW	max	1700	9,8	48	0,35	31,3	6,3	29	0,08	2,1
	min	1050	5,9	42	0,11	3,6	4,6	31	0,06	1,2
PA3215CW	max	2700	15,7	46	0,42	32,9	11,2	30	0,14	4,3
	min	1850	10,8	42	0,19	8,1	8,7	32	0,11	2,8
PA3220CW	max	3300	18,7	44	0,40	22,4	14,1	31	0,17	4,9
	min	2200	12,5	39	0,19	5,9	10,7	32	0,13	3,0

\*1) Recommended outlet air temperature for good comfort and optimized output.

\*2) Nominal output at given supply and return water temperature.

## Assembly and operating instructions

### General Instructions

Read these instructions carefully before installation and use. Keep this manual for future reference.

*The product may only be used as set out in the assembly and operating instructions. The guarantee is only valid if the product is used in the manner intended and in accordance with the instructions.*

### Application

PA3200C is a compact air curtain with a recommended installation height of 3,2 metres. The air curtain has an integrated control system and can be remotely controlled.

The air curtain is available without heat, with electrical heating and with water heating. Protection class for units with electrical heating: IP20.

Protection class for units without heating and units with water heating: IP21.

### Operation

Air is drawn in at the top of the unit and blown out downwards so that it shields the door opening and minimizes heat loss. To achieve the optimum curtain effect the unit must extend the full width of the door opening.

The grille for directing exhaust air is adjustable and is normally angled outwards to achieve the best protection against incoming cold air.

The efficiency of the air curtain depends on the air temperature, pressure differences across the doorway and any wind pressure.

*NOTE! Negative pressure in the building considerably reduces the efficiency of the air curtain. The ventilation should therefore be balanced.*

### Mounting

The air curtain unit is installed horizontally with the supply air grille facing downwards as close to the door as possible. Minimum distance from outlet to floor for electrically heated units is 1800 mm. For other minimum distances, see fig. 4.

Brackets and torx bit are enclosed in the gable end packaging upon delivery.

#### Mounting with wall brackets (fig. 6)

1. Mount the brackets on the wall, see fig.6A and dimension drawing fig.1. If the wall is uneven the brackets must be compensated for this.
2. Hook on the unit at the lower edge of the brackets. (Fig.6B-C)
3. Bend the top of the console over the the unit and slide the units screws along the rail into the slots on the consoles. (Fig.6D) When the bracket is bent once, it must be replaced if bent back more than 45 °.
4. Lock the nuts against the brackets. (Fig.6E)

#### Horizontal mounting on the ceiling

Threaded rods, hanging brackets and ceiling mounting brackets for ceiling mounting are available as accessories, see accessories pages and separate manuals.

### Electrical installation

The installation, which should be preceded by an omnipolar switch with a contact separation of at least 3 mm, should only be wired by a competent electrician and in accordance with the latest edition of IEE wiring regulations. The control system is pre-installed in the air curtain.

#### Unit without heating

Connected via the built-in control board with 1,5 m cord and plug.

#### Unit with water heating

Connected via the built-in control board with 1,5 m cord and plug.

**Unit with electrical heating**

The electrical connection is made on the top of the unit. See Fig.2. Control (230V~) and power supply for heat (400V3~) should be connected to a terminal block in the terminal box. 2-metre and longer units require dual power supplies.

The largest cable diameter for the terminal block is 16 mm<sup>2</sup>. The cable glands used must meet the protection class requirements. In the distribution board it is to be indicated that "the air curtains can be supplied from more than one connection".

See wiring diagrams.

Type	Output [kW]	Voltage [V]	Minimum area* [mm <sup>2</sup> ]
Control	0	230V~	1,5
PA3210CE08	8	400V3~	2,5
PA3215CE12	12	400V3~	4
PA3220CE16	16	400V3~	6

\*) Dimensioning of external wiring shall comply with applicable regulations and local deviations may occur.

**Start-up (E)**

When the unit is used for the first time or after a long period of disuse, smoke or odour may result from dust or dirt that has collected on the element. This is completely normal and disappears after a short time.

**Connecting the water coil (W)**

The installation must be carried out by an authorised installer.

The water coil has copper tubes with aluminium fins and is suitable for connection to a closed water heating system. The heating coil must not be connected to a mains pressure water system or an open water system.

Note that the unit shall be preceded by a regulating valve, see Frico valve kit. The water coil is connected on top of the unit via steel pipes with DN20 (3/4") terminals, external thread. Flexible hoses are available as accessories, see accessories pages.

The connections to the heating coil must be equipped with shut off valves to allow problem free removal. Water coil is equipped

with a drain valve. A vent valve should be connected at a high point in the pipe system. Air valves are not included.

NOTE: Care must be taken when connecting the pipes. Use a wrench or similar to hold the air curtain connections to prevent straining of the pipes and subsequent water leakage during connection to water supply pipe-work.

**Adjustment of the air curtain and air flow**

The direction and speed of the air flow should be adjusted considering the load on the opening. Pressure forces affect the air stream and make it bend inwards into the premises (when the premises are heated and the outdoor air is cold).

The air stream should therefore be directed outwards to withstand the load. Generally speaking, the higher the load, the greater the angle that is needed.

**Basic setting fan speed**

The fan speed when the door is open is set using the control. Note that the air flow direction and fan speed may need fine adjustment depending on the loading of the door.

**Filter (W)**

The water coil is protected against dirt and blockage by an internal air filter which covers the coil face. In environments where the filter needs cleaning often, it is advisable to use an external intake filter (see accessories pages), which provides an easier maintenance, since the unit does not need to be opened. When an external filter is used, the internal filter is removed.

**Service, repairs and maintenance**

For all service, repair and maintenance first carry out the following:

1. Disconnect the power supply.
2. The front hatch is removed by removing the screws on the top of the unit and then detach the bent edge at the bottom. (Fig.3)
3. After the service, repair and maintenance reattach the front hatch. Place the hatch at the lower edge with the bent edge and fasten on top with screws.

Note that when carrying out work where the end is removed, the outlet grille also detaches.

## **Maintenance**

---

### *Unit with water heating*

The appliance filter should be cleaned regularly to ensure the air curtain effect and the heat emission from the device. How often depends on local circumstances. A clogged filter is not a risk, but the appliance function can fail.

1. Disconnect the power supply.
2. The front hatch is removed by removing the screws on the top of the unit and then detach the bent edge at the bottom. (Fig.3)
3. Remove the filter and vacuum clean or wash it. If the filter is clogged or damaged, it may need to be changed.

### *All units:*

Since fan motors and other components are maintenance free, no maintenance other than cleaning is necessary. The level of cleaning can vary depending on local conditions. Undertake cleaning at least twice a year. Inlet and exhaust grilles, impeller and elements can be vacuum cleaned or wiped using a damp cloth. Use a brush when vacuuming to prevent damaging sensitive parts. Avoid the use of strong alkaline or acidic cleaning agents.

## **Overheating**

---

The air curtain unit with electric heater is equipped with an overheat protector. If it is deployed due to overheating, reset as follows:

1. Disconnect the electricity with the fully isolated switch.
2. Determine the cause of overheating and rectify the fault.
3. Remove the front hatch.
4. Press the red button located inside the air curtain unit, at the inner gable of the terminal box.
5. Reattach the front hatch and connect the unit again.

All motors are equipped with an integral thermal safety cut-out. This will operate, stopping the air curtain should the motor

temperature rise too high. The cut-out will automatically reset when the motor temperature has returned to within the motor's operating limits.

## **Temperature control**

---

See control pages.

## **Replacing motor or impeller**

---

1. Remove gable end.
2. Remove the screw between motor and fan.
3. Disconnect the cables to the motor.
4. Remove the screws securing the motor and lift it out together with the impeller.
5. Install the new motor and/or the new impeller as above in reverse order.

## **Replacing heating elements/heating package (E)**

---

1. Mark and disconnect the cables to the heating elements/package
2. Remove the mounting screws securing the heating elements/package in the unit and lift the heating elements/package out.
3. Install the new heating elements/package in reverse order to the above.

## **Replacing the water coil (W)**

---

1. Shut off the water supply to the unit.
2. Disconnect the connections to the water coil.
3. Detach the plastic ends.
4. Detach the intake grille by drilling out the rivet(s).
5. Remove the mounting screws securing the coil in the unit and lift the coil out.
6. Install the new coil in reverse order to the above.

## **Draining the water coil (W)**

---

The drain valve is on the underside of the coil on the connector side. It can be accessed via the front hatch.

## Trouble shooting

---

*If the fans are not working or do not blow properly, check the following:*

- The functions and settings of the built-in control system.
- That the intake grille/filter is not dirty.

*If there is no heat, check the following:*

- The functions, internal sensor and settings of the built-in control system.

*For units with electrical heating, also check the following:*

- Power supply to electric heater coil; check fuses and circuit-breaker (if any).
- That the overheat protection for the motors has not been deployed.

*For units with water coil, also check the following:*

- That the water coil is air free.
- That there is enough water flow.
- That incoming water is heated enough.

If the fault cannot be rectified, please contact a qualified service technician.

## Residual current circuit breaker (E)

---

When the installation is protected by means of a residual current circuit breaker, which trips when the appliance is connected, this may be due to moisture in the heating element. When an appliance containing a heater element has not been used for a long period or stored in a damp environment, moisture can enter the element.

This should not be seen as a fault, but is simply rectified by connecting the appliance to the main supply via a socket without a safety cut-out, so that the moisture can be eliminated from the element. The drying time can vary from a few hours to a few days. As a preventive measure, the unit should occasionally be run for a short time when it is not being used for extended periods of time.

## Safety

---

- *For all installations of electrically heated products should a residual current circuit breaker 300 mA for fire protection be used.*
- *Keep the areas around the air intake and exhaust grilles free from possible obstructions!*
- *The unit may have hot surfaces during operation and when cooling down!*
- *The unit must not be fully or partially covered with clothing, or similar materials, as overheating can result in a fire risk! (E)*
- *Lifting equipment must be used to lift the unit.*
- *This appliance can be used by children aged from 8 years and above and persons with reduced physical, sensory or mental capabilities or lack of experience and knowledge if they have been given supervision or instruction concerning use of the appliance in a safe way and understand the hazards involved. Children shall not play with the appliance. Cleaning and user maintenance shall not be made by children without supervision.*

**Controls**

The air curtain has an integrated control system and can be remotely controlled.

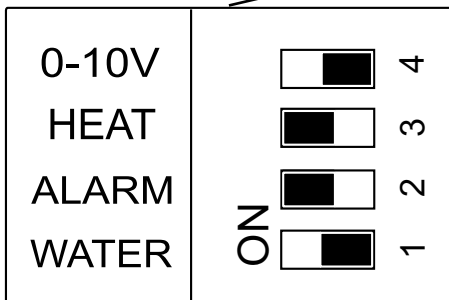
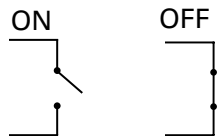
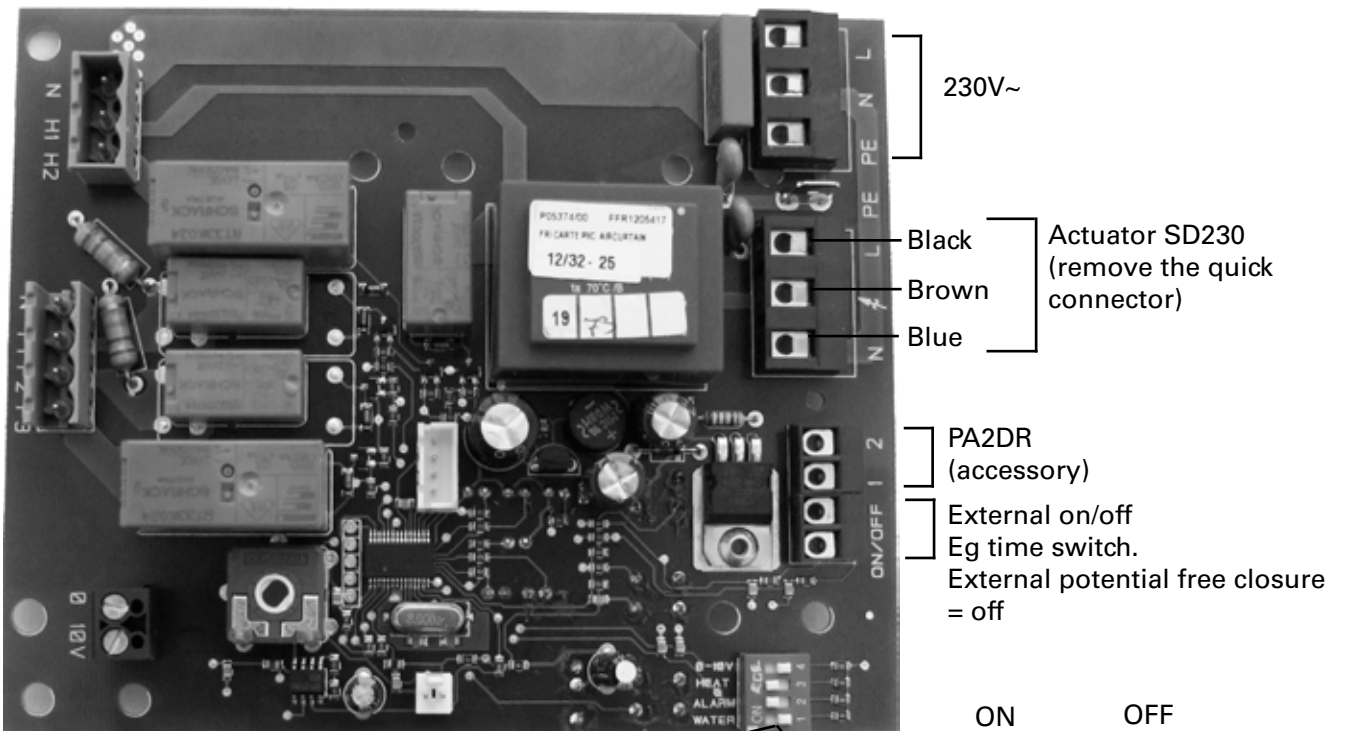
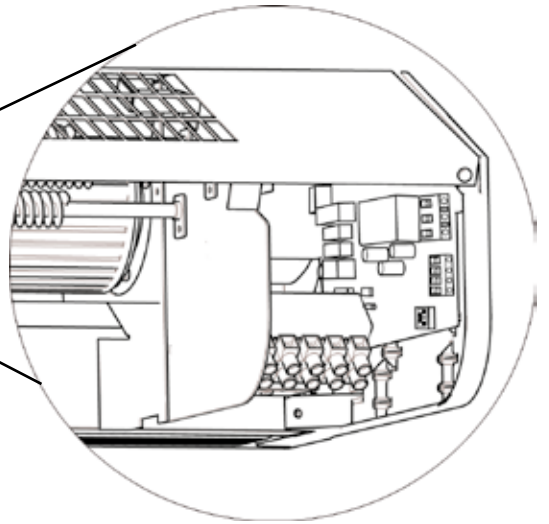
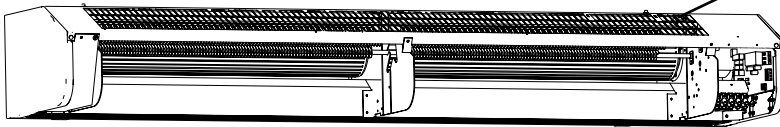

Factory setting dip-switches - Unit without heating or with electrical heating

Dip-switch 3 is used for PA2DR (optional).

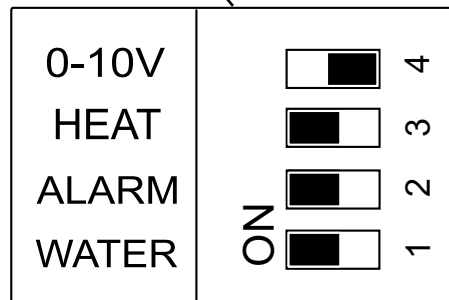

Factory setting dip-switches - Unit with water heating

Dip-switch 3 is used for PA2DR (optional).

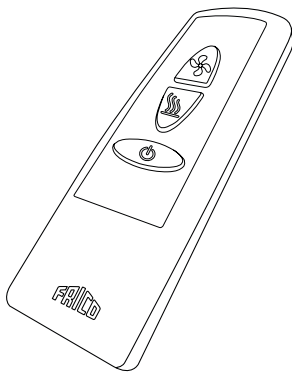
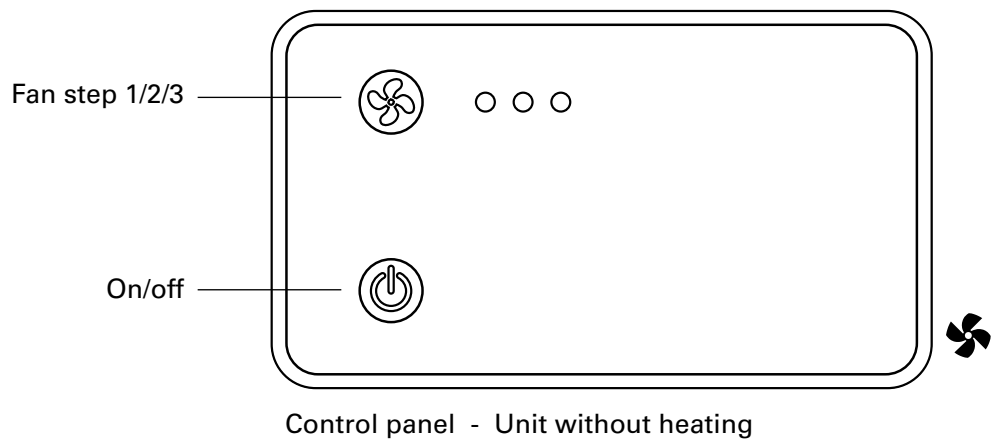
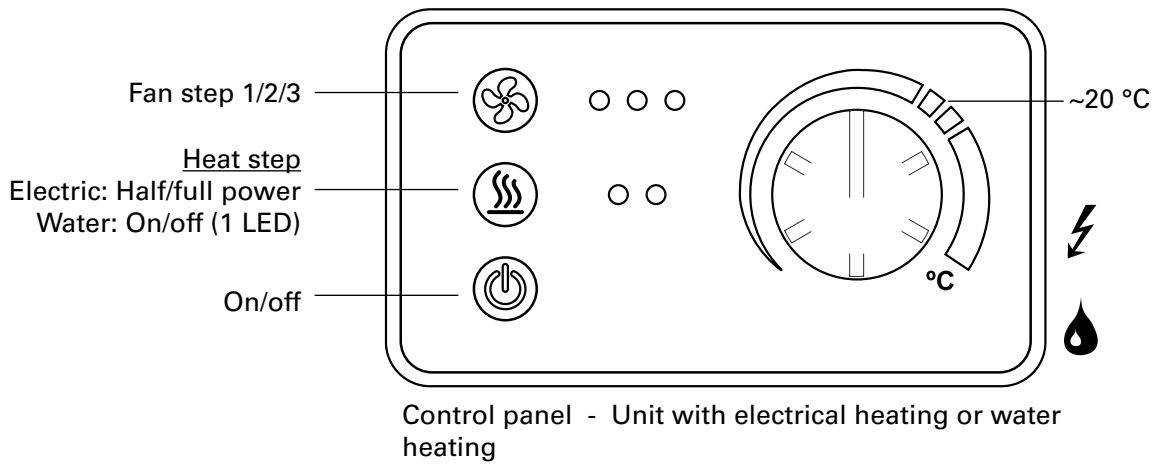

Remote control - on/off, fan steps and heating steps

**Functional test**

Functional test is started using the remote control.

Push



and



in 5 seconds

Fan and heatings steps are tested in 10-second intervals which is indicated by lighted LEDs. When the test is completed, all LEDs will flash for 30 seconds.

**Temperature control**

If the temperature exceeds 50 °C, the fan runs at full speed for 2 minutes to vent out the heat, if the temperature rises above 50 °C again during the following 5 minutes overheating alarm is deployed. The red LEDs flash and all the buttons are locked.

1. Disconnect the electricity with the fully isolated switch.
2. Determine the cause of overheating and rectify the fault.
3. Connect the unit again.









**Main office**

Frico AB  
Box 102  
SE-433 22 Partille  
Sweden

Tel: +46 31 336 86 00

mailbox@frico.se  
www.frico.se

**For latest updated information and information  
about your local contact: [www.frico.se](http://www.frico.se)**