



PA2500

Stylish air curtain for entrances, with intelligent control

Recommended installation height 2,5 m

PA2500 creates a temperature dividing air barrier that effectively prevents cold drafts and gives excellent heating comfort in door ways, such as shops, offices and public premises.

- 3 fan steps and 3 electrical heating steps, which give more even comfort and extra energy savings.
- Wall brackets included.
- The front is easy to remove, which facilitates installation and allows easy maintenance.
- Corrosion proof housing made of hot zinc-plate and powder enamelled steel panels. Plastic ends. Colour front: white, RAL 9016, NCS S 0500-N. Colour grille, rear section, ends and brackets: grey, RAL 7046.



Optimized airflow with Thermozone technology.

🌀 Ambient, no heat - PA2500 A

IP21

Type	Output [kW]	Airflow*1 [m³/h]	Sound level*2 [dB(A)]	Voltage motor [V]	Amperage motor [A]	Length [mm]	Weight [kg]
PA2510A	0	900/1300	43/53	230V~	0,5	1050	16
PA2515A	0	1250/2100	44/54	230V~	0,7	1560	23,5
PA2520A	0	1800/2600	44/55	230V~	1,0	2050	32

⚡ Electrical heat - PA2500 E

IP20

Type	Output steps [kW]	Airflow*1 [m³/h]	Δt^{*3} [°C]	Sound level*2 [dB(A)]	Voltage motor [V]	Amperage motor [A]	Voltage [V] Amperage [A] (heat)	Length [mm]	Weight [kg]
PA2510E05	1,7/3,3/5	900/1450	17/10,5	42/51	230V~	0,5	400V3~/7,2	1050	19
PA2510E08	3/5/8	900/1450	27/16,5	42/51	230V~	0,5	400V3~/11,5	1050	20
PA2515E08	2,7/5,4/8	1400/2200	17,5/11	40/52	230V~	0,7	400V3~/11,5	1560	30
PA2515E12	3,9/8/12	1400/2200	26/16,5	40/52	230V~	0,7	400V3~/17,3	1560	32
PA2520E10	3,4/6,7/10	1800/2900	17/10,5	43/53	230V~	1,0	400V3~/14,4	2050	36
PA2520E16	6/10/16	1800/2900	27/16,5	43/53	230V~	1,0	400V3~/23,1	2050	40

💧 Water heat - PA2500 W

IP21

Type	Output**4 [kW]	Airflow*1 [m³/h]	$\Delta t^{*3,4}$ [°C]	Water volume [l]	Sound level*2 [dB(A)]	Voltage motor [V]	Amperage motor [A]	Length [mm]	Weight [kg]
PA2510W	4,7	900/1300	12/11	0,71	42/53	230V~	0,45	1050	17,5
PA2515W	9,2	1250/2100	16/13	1,09	41/54	230V~	0,6	1560	26
PA2520W	11	1800/2600	15/13	1,42	43/55	230V~	0,9	2050	35

*1) Lowest/highest airflow of totally 3 fan steps.

*2) Conditions: Distance to the unit 5 metres. Directional factor: 2. Equivalent absorption area: 200 m². At lowest/highest airflow.

*3) Δt = temperature rise of passing air at maximum heat output and lowest/highest airflow.

*4) Applicable at water temperature 60/40 °C, air temperature, in +18 °C.

Air velocity profile

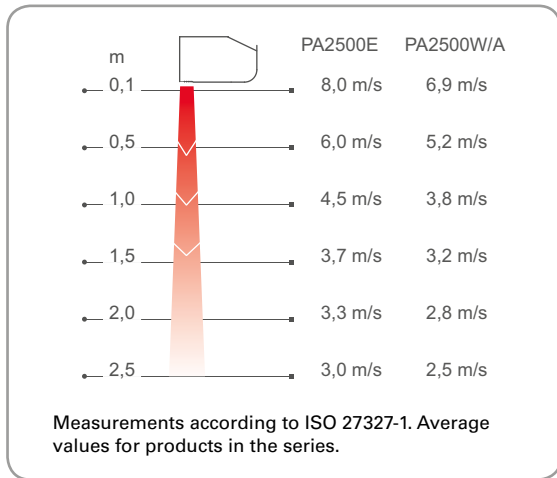

Control

SIRe Basic SIRe Competent SIRe Advanced

This air curtain is supplied prepared for the SIRe control system that has many smart and energy saving functions. There are three different levels with different functionality to choose from, Basic, Competent or Advanced. Valve kit VOS(P), VOT, VMO(P) or VMT is used to control the water flow. For further information and options, see the "Controls" section.

Dimensions

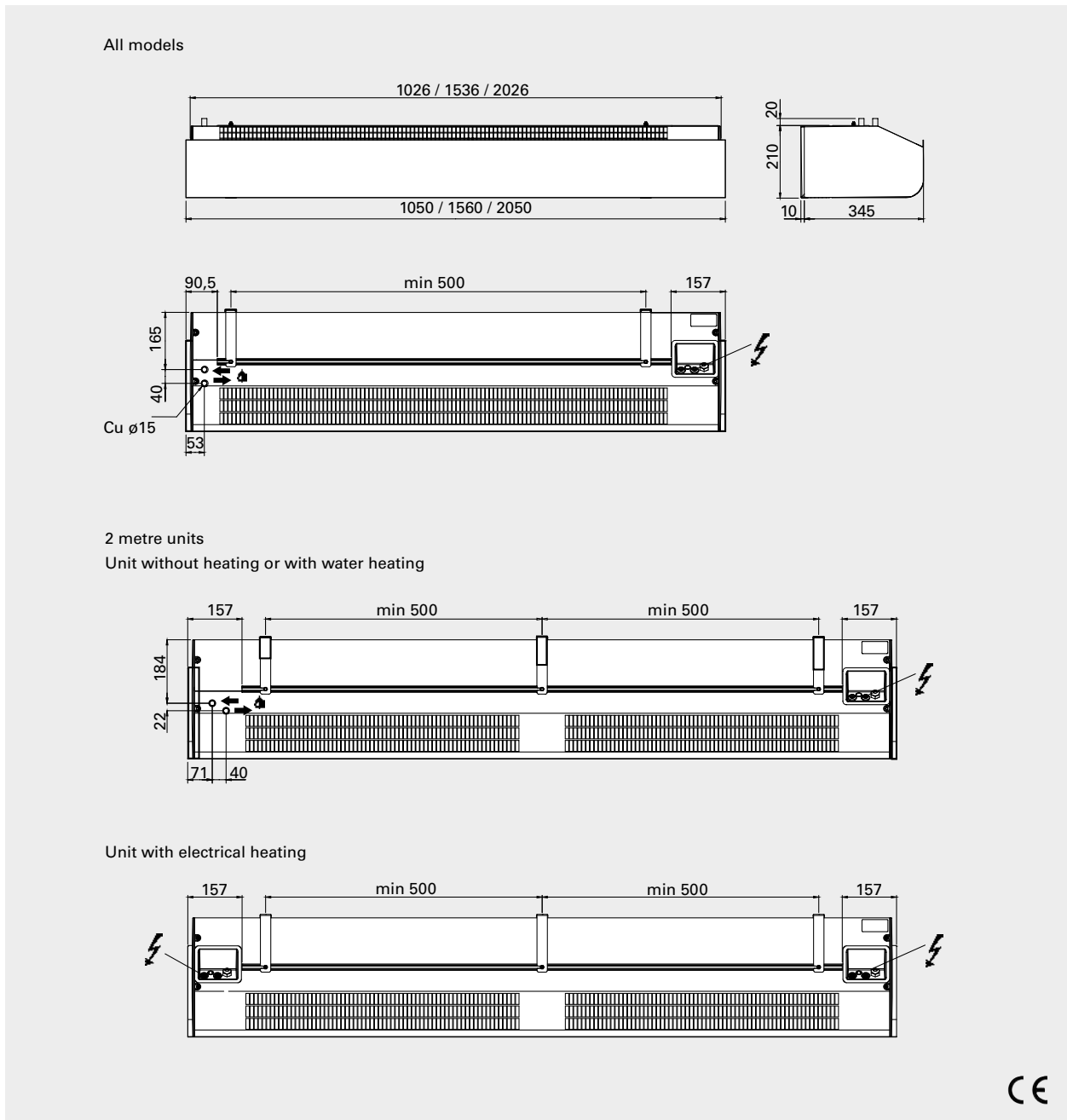

Accessories

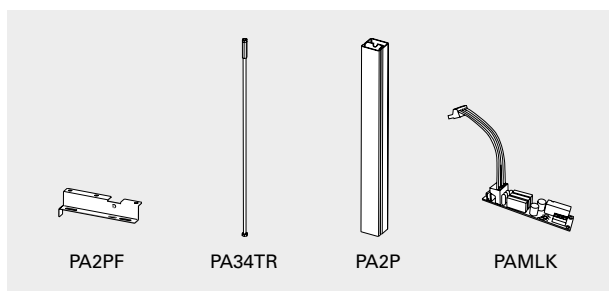

PA2PF, ceiling mounting brackets
Mountings for installing the unit in the ceiling using hanging brackets or threaded bars (not included).

PA34TR, threaded bars
Threaded bars for installing unit on to a ceiling. Length 1 m. Used together with ceiling mounting brackets PA2PF/PA3PF.

PA2P, hanging brackets
Hanging brackets for installing the unit suspended from the ceiling. Length 1 m. The hanging brackets are covered by a white plastic trim to cover the cables. The brackets may be cut to shorter length, if required. Used together with ceiling mounting brackets PA2PF/PA3PF.

PAMLK, motor alarm board
Accessory allows connection for a motor alarm signal in units where this facility is not already available. PAMLK plugs between motor wiring harness and main PC board. For units with SIRE control (PA2500, AR3200) connection enables use of the provided motor protection terminals. For units without SIRE (PA2200/3200C, AR3200C), use potential free contact on PAMLK board.

Unit with water heating

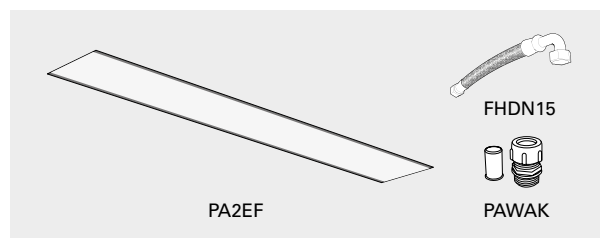

PA2EF, external intake filter
Fine mesh filter that prevents ingress of dirt and deposits to water heated units. The filter is easy to attach and remove thanks to the integrated magnetic strips. Makes maintenance easier since the unit does not need to be opened.

PAWAK, water connection kit
Kit with pipe connections with compression fitting on one end and outside thread (1/2" DN15) on the other to facilitate the connection of the plain copper pipes at the water coil.

FHDN15, flexible hoses
Flexible hoses for easy and practical installation of water heated unit. Used together with water connection kit PAWAK or similar. DN15.

Type	Description	Quantity included	Length
PA2PF15	Ceiling mounting brackets for 1 and 1,5 metre units	4	
PA2PF20	Ceiling mounting brackets for 2 metre units	6	
PA34TR15	Threaded bars for 1 and 1,5 metre units	4	1 m
PA34TR20	Threaded bars for 2 metre units	6	1 m
PA2P15	Hanging brackets for 1 and 1,5 metre units	2	1 m
PA2P20	Hanging brackets for 2 metre units	3	1 m
PAMLK	Motor alarm board	1	
PA2EF10	External intake filter for 1 metre water heated units	1	
PA2EF15	External intake filter for 1,5 metre water heated units	1	
PA2EF20	External intake filter for 2 metre water heated units	1	
PAWAK	Water connection kit	1	
FHDN15	Flexible hoses DN15, inside thread, 90° bend	2	1 m