

## Thermozone AD Corinte W - ADCS

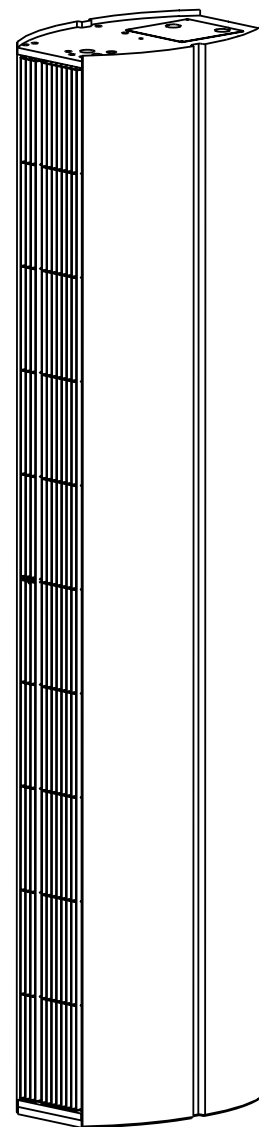

SE ..20

GB ..23

NO ..26

FR ..29

RU ..32

DE ..35

NL ..38

ES ..41

PL ..44

FI ..47

IT ..50

DK ..53

# Thermozone AD Corinte W - ADCS

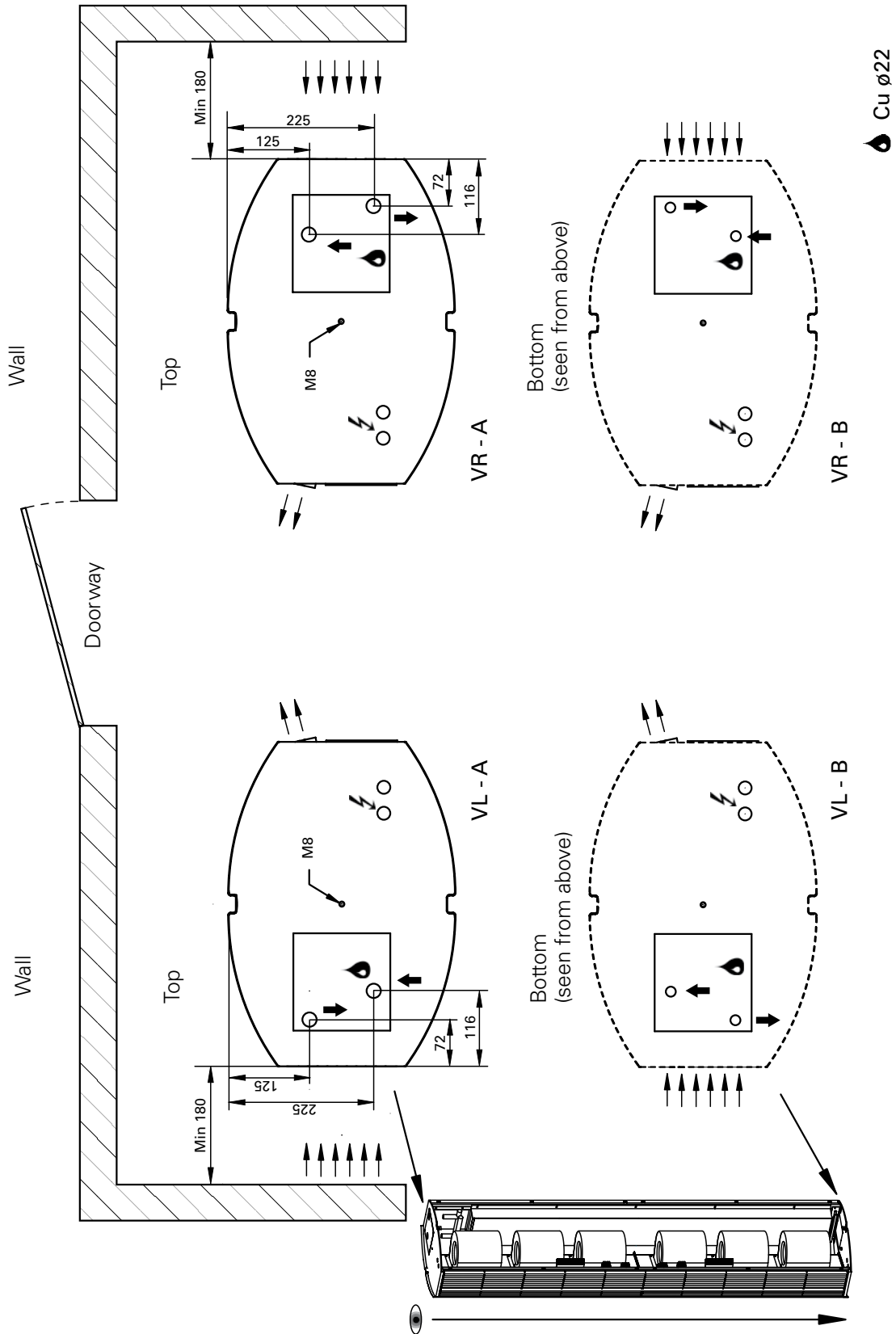

Fig 1

# Thermozone AD Corinte W - ADCS

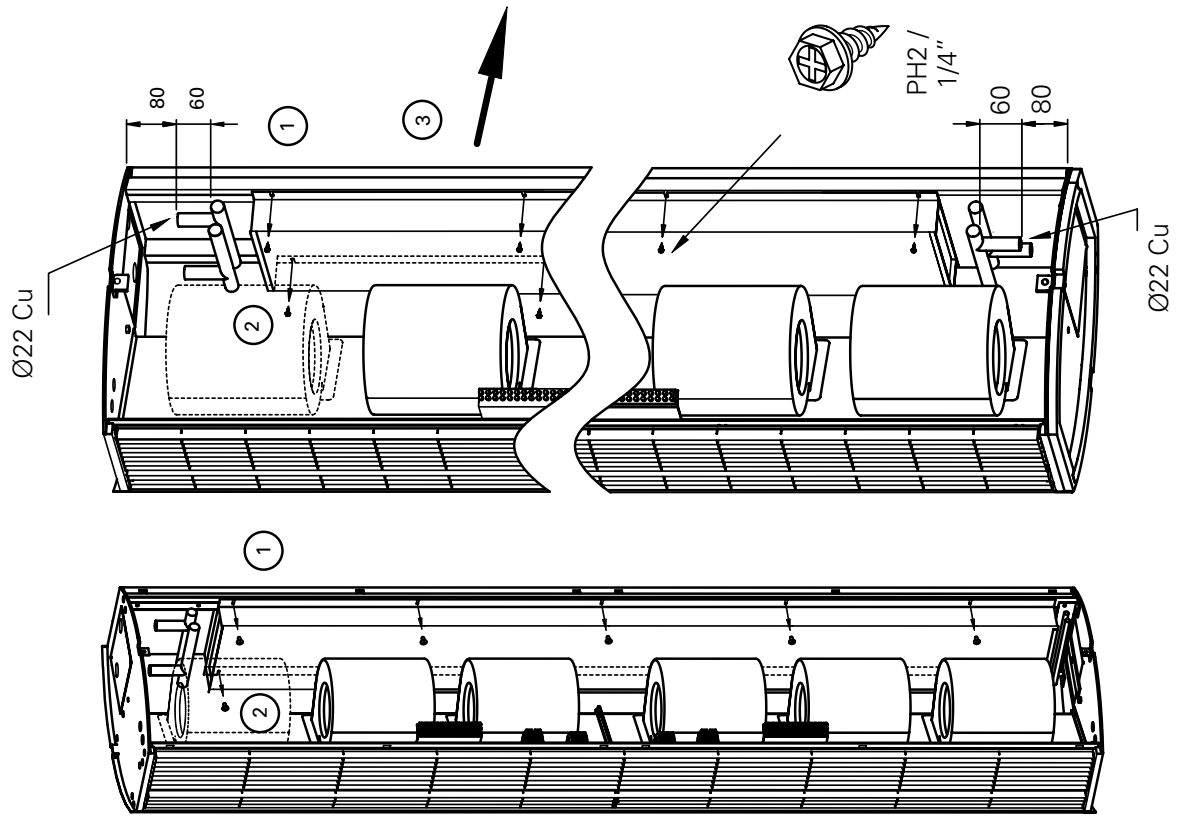

Fig 3

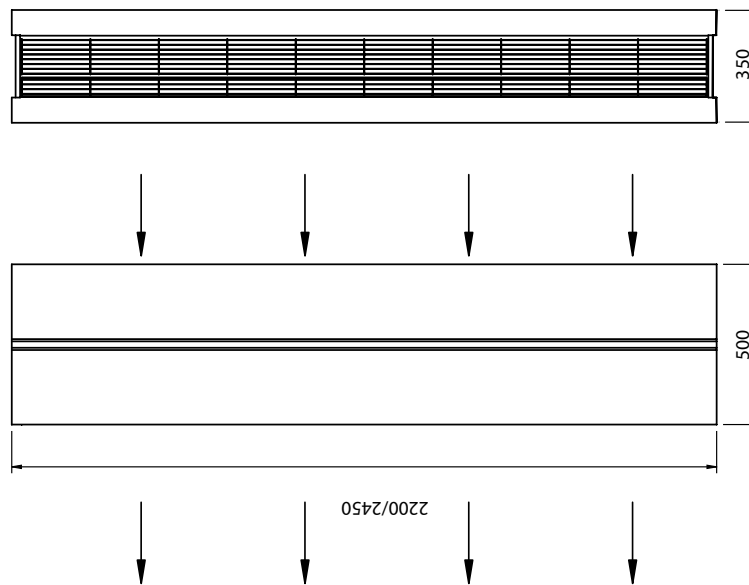

Fig 2

Thermozone AD Corinte W - ADCS

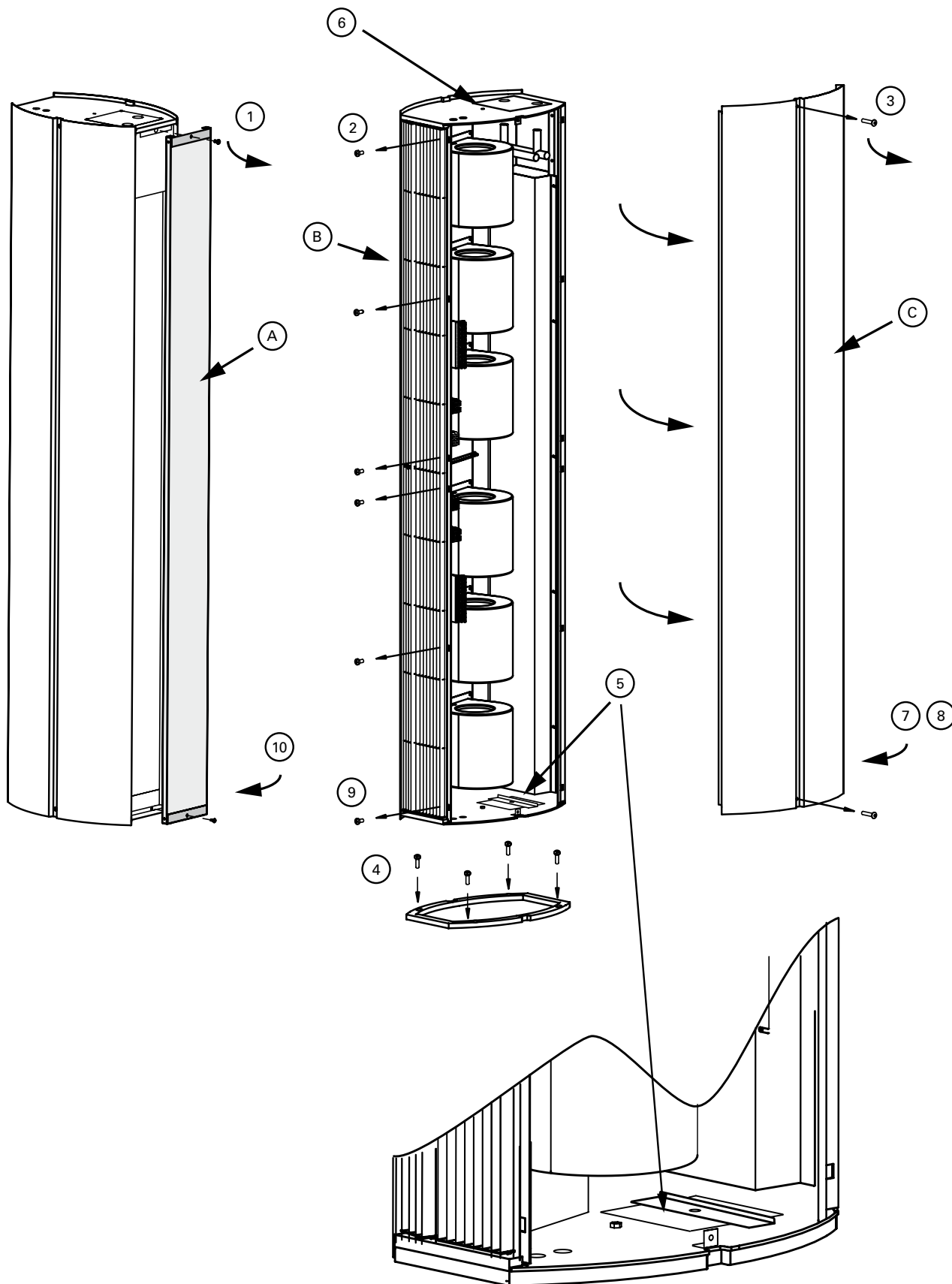

Fig 4

Thermozone AD Corinte W - ADCS

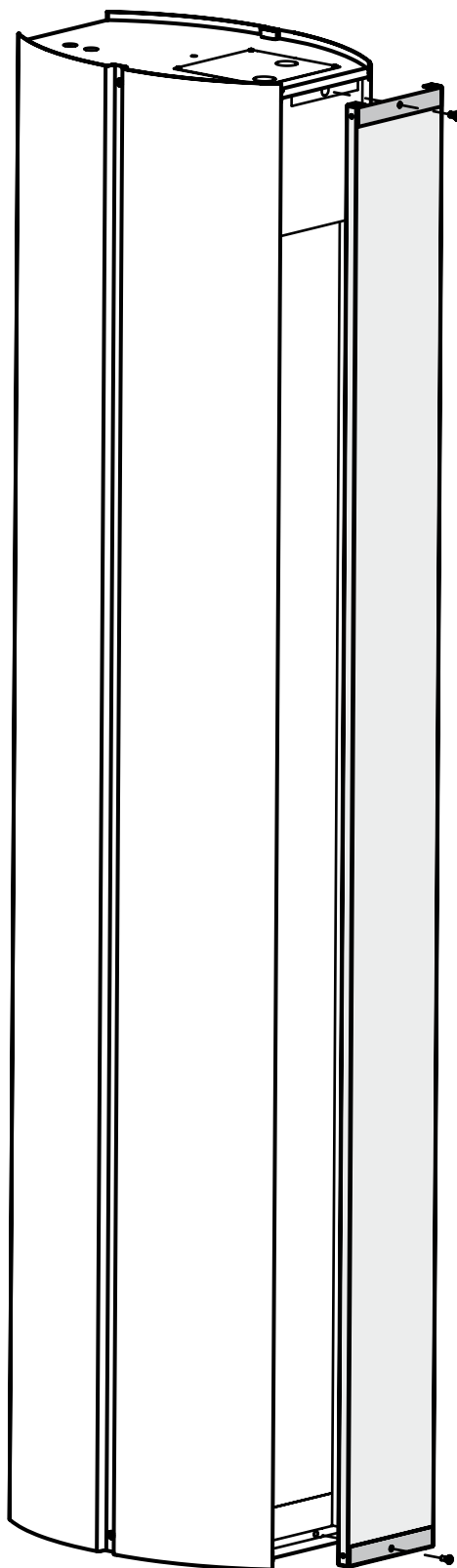

Fig 5

# Thermozone AD Corinte W - ADCS

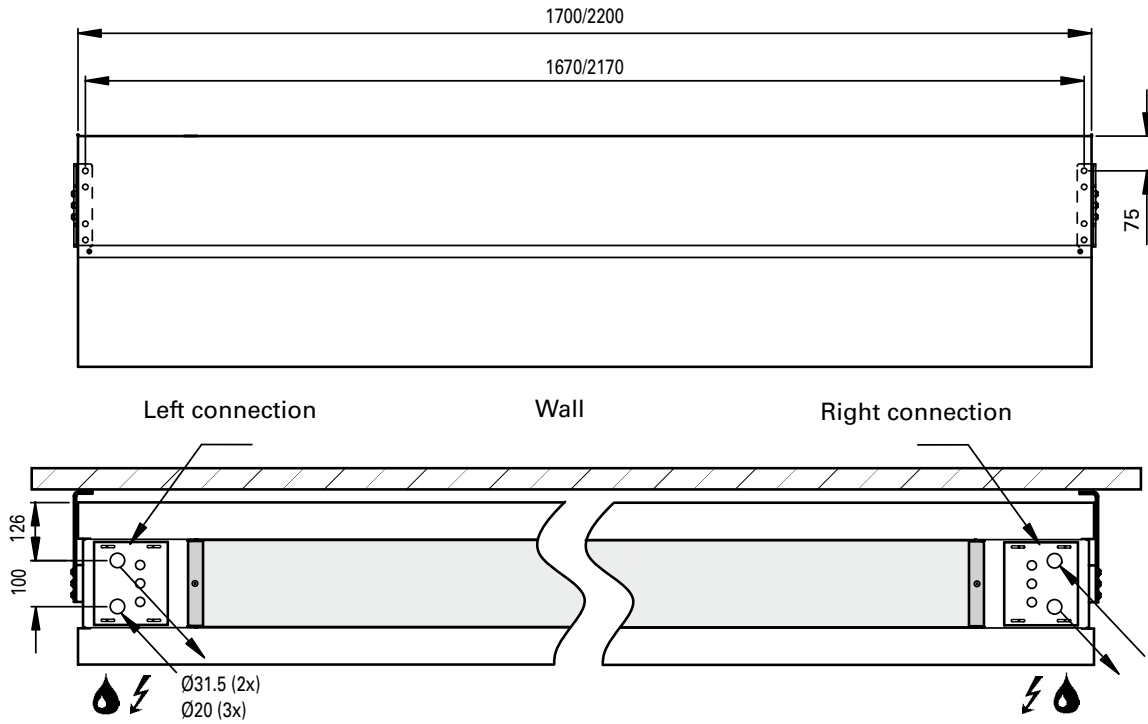

Fig 6a

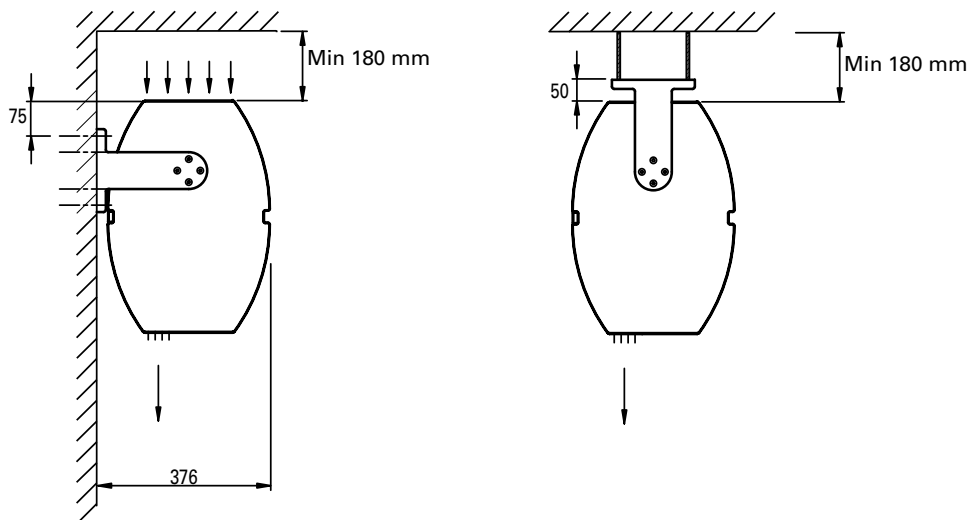

Fig 6b

# Thermozone AD Corinte W - ADCS

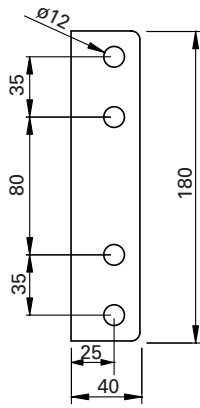

Fig 6c

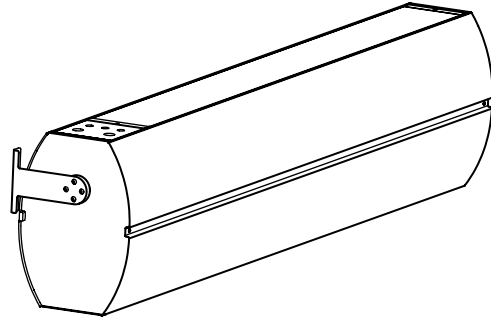

Fig 6d

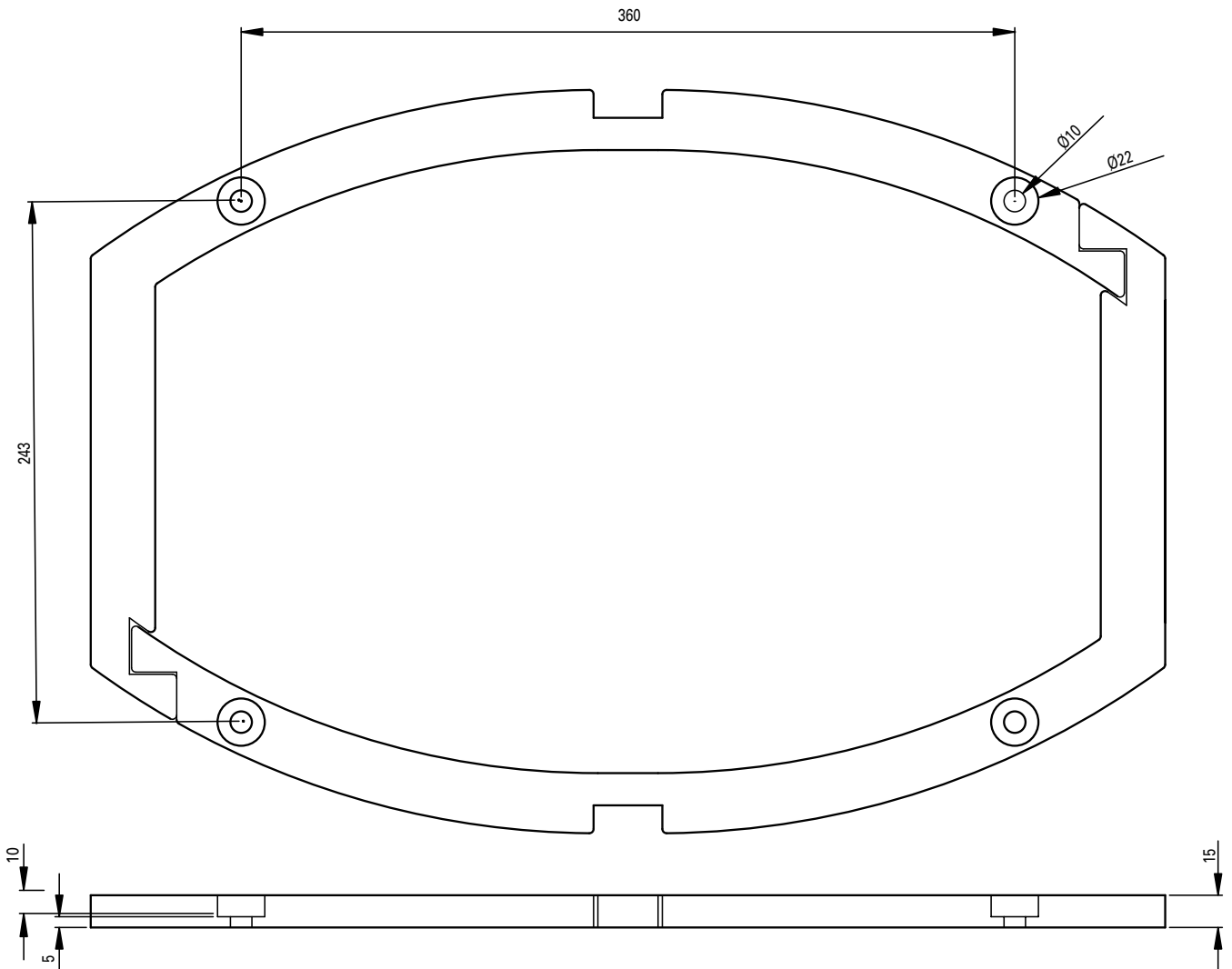
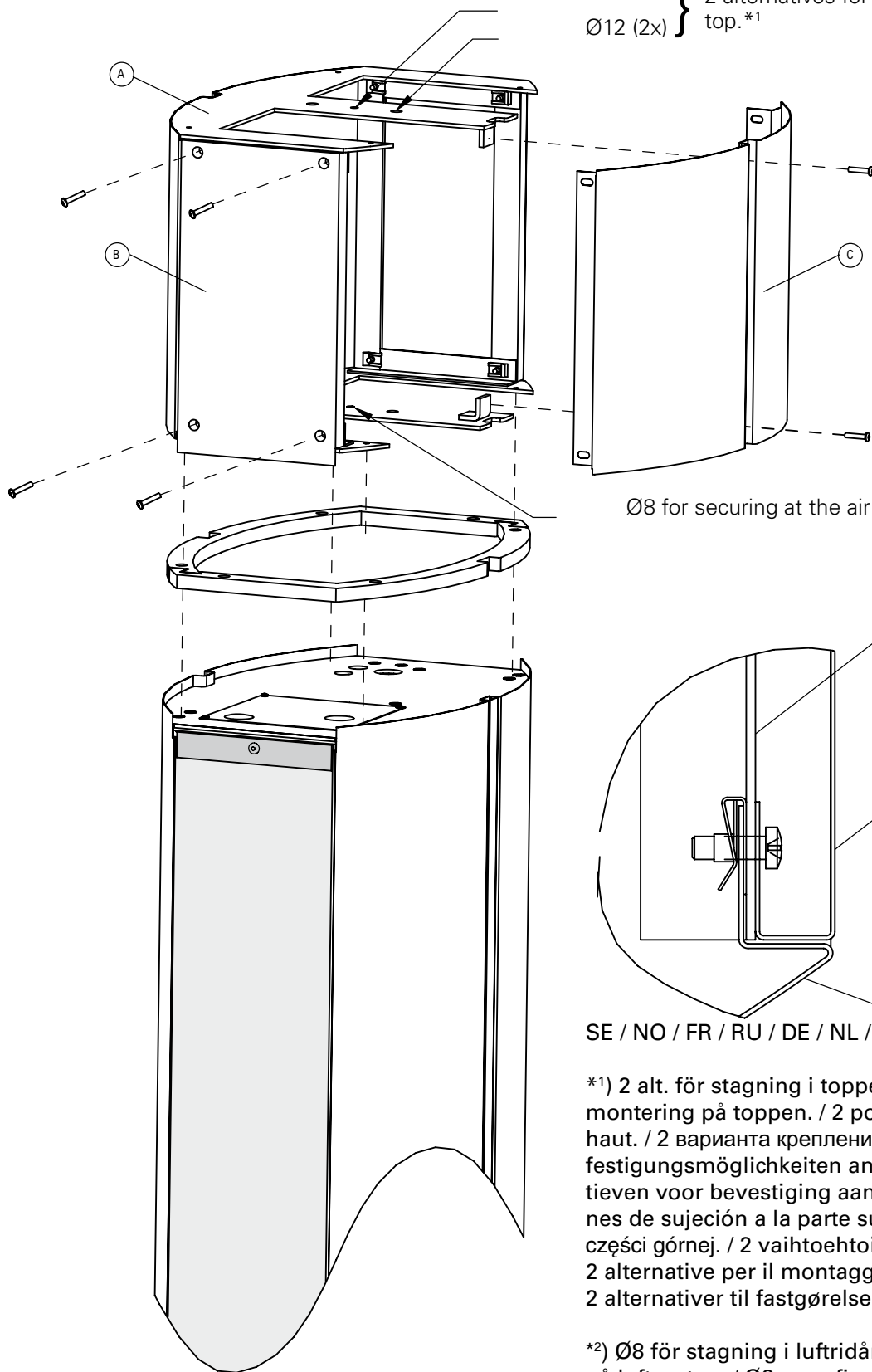

Fig 7

ADCEH

Ø8 } 2 alternatives for securing at the  
 Ø12 (2x) } top.\*1



Ø8 for securing at the air curtain.\*2

SE / NO / FR / RU / DE / NL / ES / PL / FI / IT / DK

\*1) 2 alt. för stagning i toppen. / 2 muligheter for montering på toppen. / 2 possibilités de fixation par le haut. / 2 варианта крепления верхней части / Zwei Befestigungsmöglichkeiten an der Oberseite / 2 alternatieven voor bevestiging aan de bovenkant. / 2 opciones de sujeción a la parte superior. / 2 opcje montażu w części górnej. / 2 vaihtoehdoista kiinnitystapaa. / 2 alternative per il montaggio sulla parte superiore. / 2 alternativer til fastgørelse foroven.

\*2) Ø8 för stagning i luftridån. / Ø8 for montering på luftporten. / Ø8 pour fixation du rideau d'air. / Для крепления к завесе / Ø 8 zur Befestigung am Luftschleier / Ø8 voor bevestiging aan het luchtgordijn. / Ø8 para sujeción a la cortina de aire. / Ø8 do zamocowania kurtyny powietrznej. / Ø8 ilmaverhokojen kiinnitykseen. / Ø8 per il montaggio sulla barriera d'aria. / Ø8 til fastgørelse af lufttæppet.

**ADCS - SIRe**

Fig 8

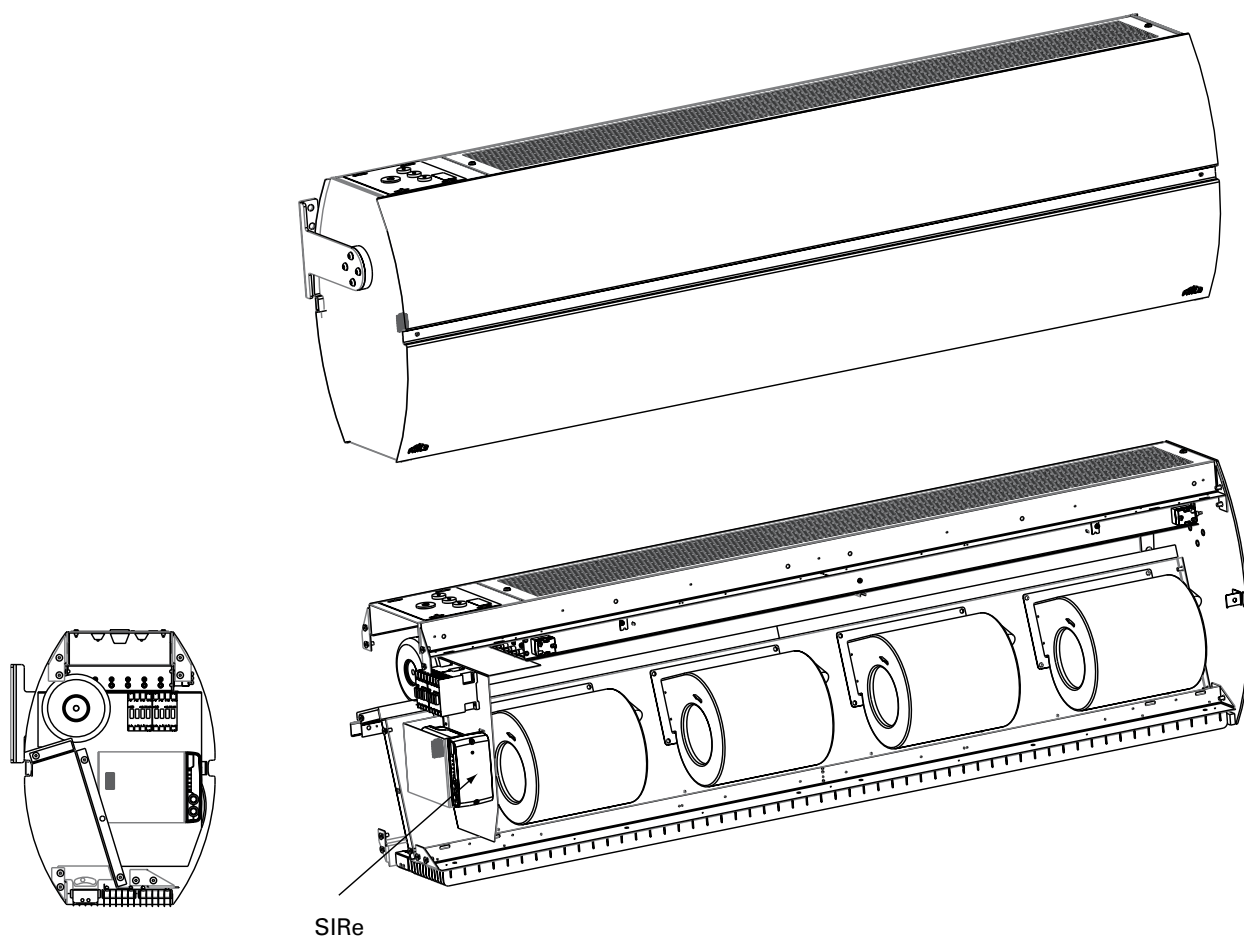

## Regulations alternatives

This aircurtain is supplied with an intelligent and well designed low voltage control system SIRE which can be customized for each unique application and environment. The control system is pre-installed in the aircurtain with an integrated control card.

SIRE is supplied pre-programmed with quick-release connections and is very easy to use and install. There are three different levels with different functionality to choose from, Basic, Competent or Advanced.

Type	RSK-nr	Description	HxWxD [mm]	L [m]
<b>SIReB</b>		Control system Basic		
<b>SIReAC</b>		Control system Competent		
<b>SIReAA</b>		Control system Advanced		
<b>SIReRTX</b>	673 09 22	External room temperature sensor	70x33x23	
<b>SIReUR*</b>	673 09 21	Kit for recessed installation	114x70x50	
<b>SIReWTA</b>		Clamp-on sensor		
<b>SIReCJ4</b>		Joint piece for two pcs. RJ11 (4p/4c)		
<b>SIReCJ6</b>		Joint piece for two pcs. RJ11 (6p/6c)		
<b>SIReCC603</b>	673 09 23	Modular cable RJ11 (6p/6c)		3
<b>SIReCC605</b>	673 09 24	Modular cable RJ11 (6p/6c)		5
<b>SIReCC610</b>	673 09 25	Modular cable RJ11 (6p/6c)		10
<b>SIReCC615</b>	673 09 26	Modular cable RJ11 (6p/6c)		15
<b>SIReCC403</b>	673 09 27	Modular cable RJ11 (4p/4c)		3
<b>SIReCC405</b>	673 09 28	Modular cable RJ11 (4p/4c)		5
<b>SIReCC410</b>	673 09 29	Modular cable RJ11 (4p/4c)		10
<b>SIReCC415</b>	673 09 30	Modular cable RJ11 (4p/4c)		15

## Water regulation

Type	Description	Voltage [V]	Connection
<b>VOS15LF</b>	Valve kit on/off	230 V	DN15
<b>VOS15NF</b>	Valve kit on/off	230 V	DN15
<b>VOS20</b>	Valve kit on/off	230 V	DN20
<b>VOS25</b>	Valve kit on/off	230 V	DN25
<b>VOSP15LF</b>	Pressure independent valve kit	230 V	DN15
<b>VOSP15NF</b>	Pressure independent valve kit	230 V	DN15
<b>VOSP20</b>	Pressure independent valve kit	230 V	DN20
<b>VOSP25</b>	Pressure independent valve kit	230 V	DN25
<b>VMO15LF</b>	Modulating valve kit	24 V	DN15
<b>VMO15NF</b>	Modulating valve kit	24 V	DN15
<b>VMO20</b>	Modulating valve kit	24 V	DN20
<b>VMO25</b>	Modulating valve kit	24 V	DN25
<b>VMOP15LF</b>	Pressure independent and modulating valve kit	24 V	DN15
<b>VMOP15NF</b>	Pressure independent and modulating valve kit	24 V	DN15
<b>VMOP20</b>	Pressure independent and modulating valve kit	24 V	DN20
<b>VMOP25</b>	Pressure independent and modulating valve kit	24 V	DN25
<b>VOT15</b>	Three way valve and actuator on/off	230 V	DN15
<b>VOT20</b>	Three way valve and actuator on/off	230 V	DN20
<b>VOT25</b>	Three way valve and actuator on/off	230 V	DN25
<b>VMT15</b>	Three way valve and modulating actuator	24 V	DN15
<b>VMT20</b>	Three way valve and modulating actuator	24 V	DN20
<b>VMT25</b>	Three way valve and modulating actuator	24 V	DN25
<b>VAT</b>	Adjustment tool for valve kit VOS, VOSP, VMO, VMOP		

## Wiring diagrams

### Internal wiring diagram

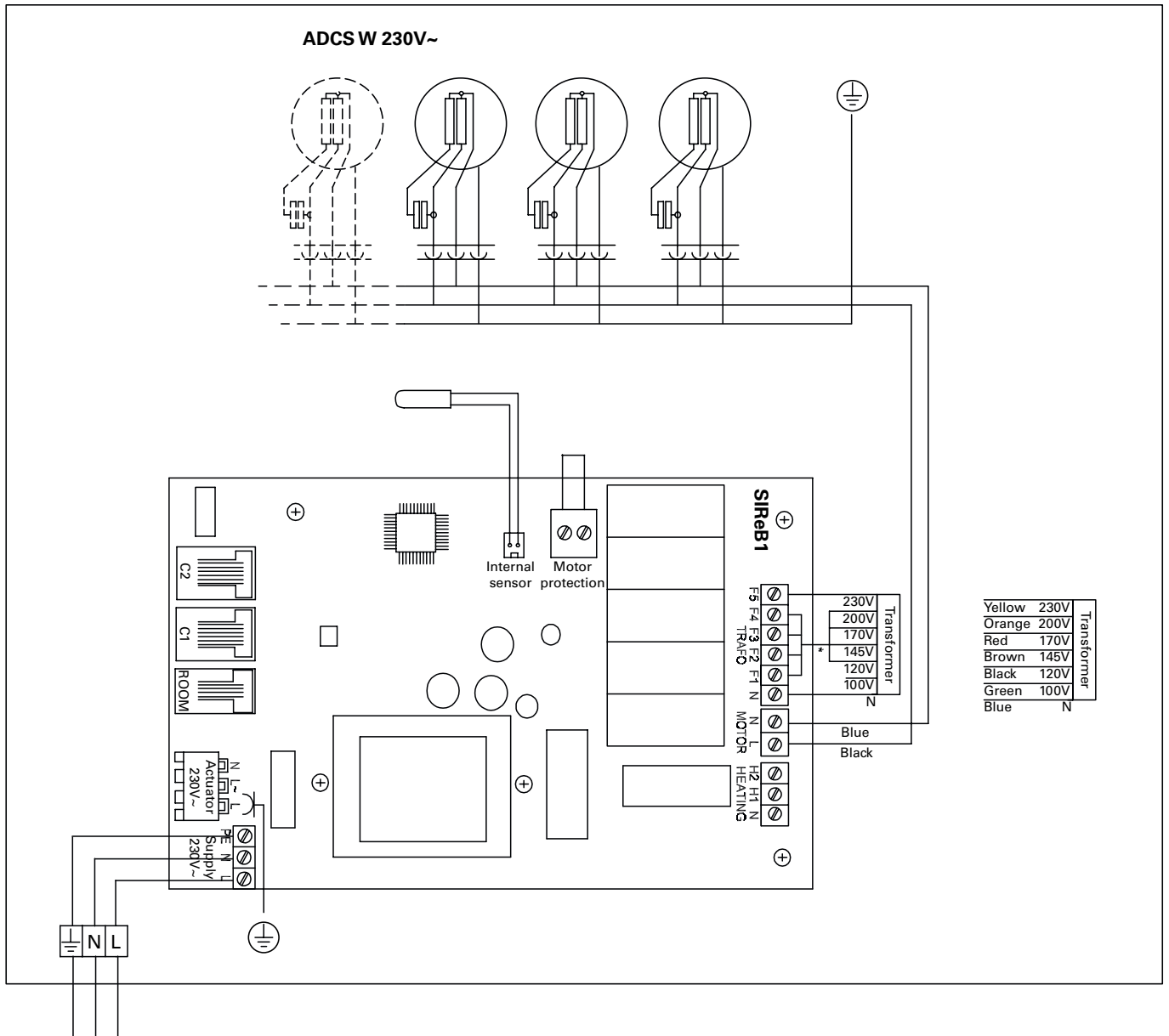

## Wiring diagrams

### Basic

#### SIReB1

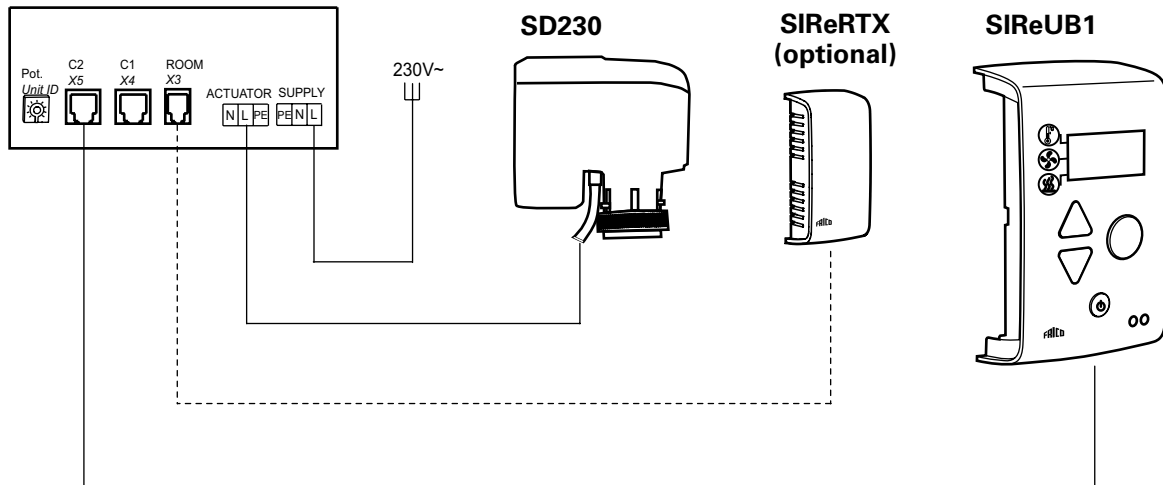

### Basic - parallel

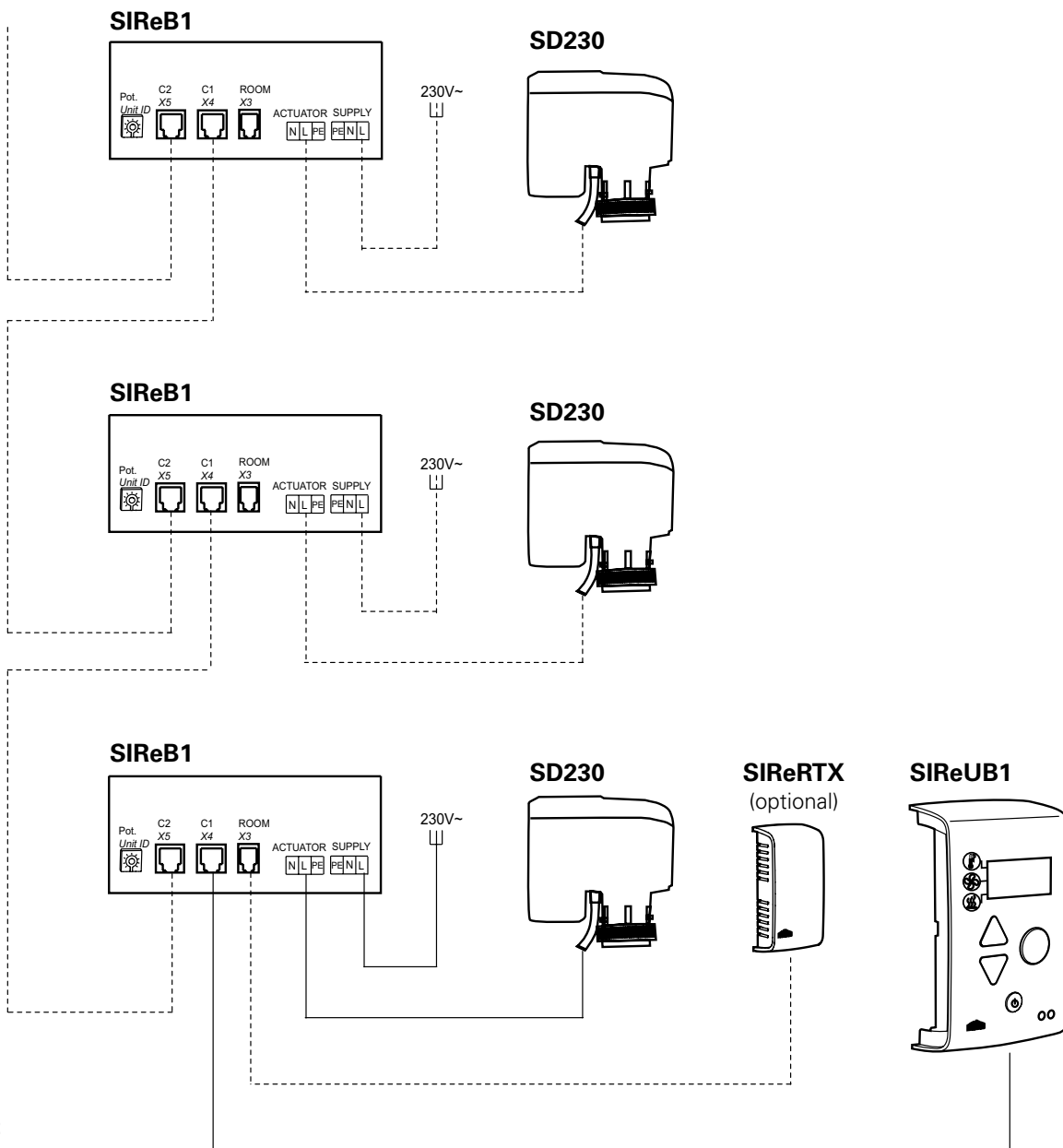

Competent

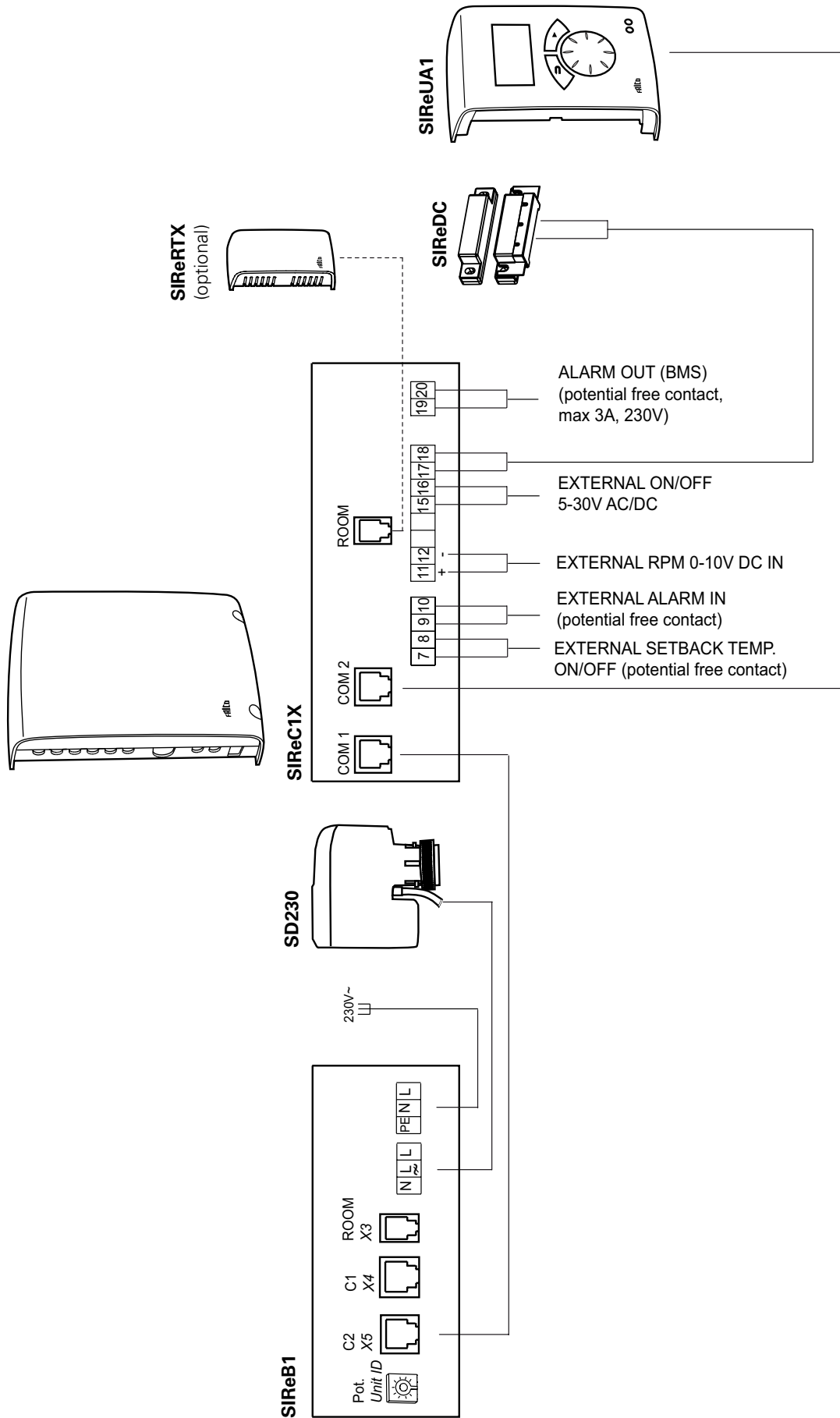

Competent - parallel

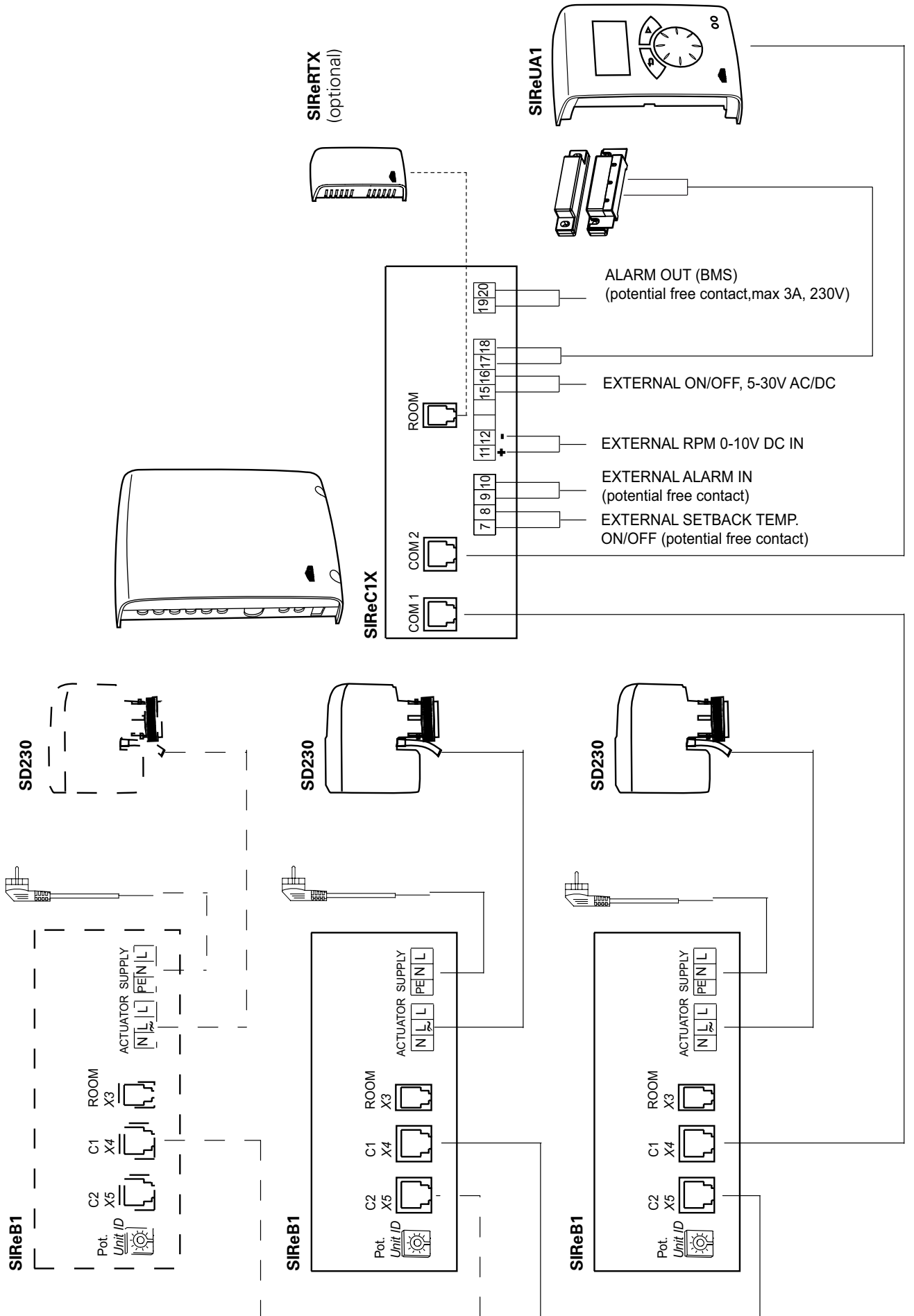

Advanced

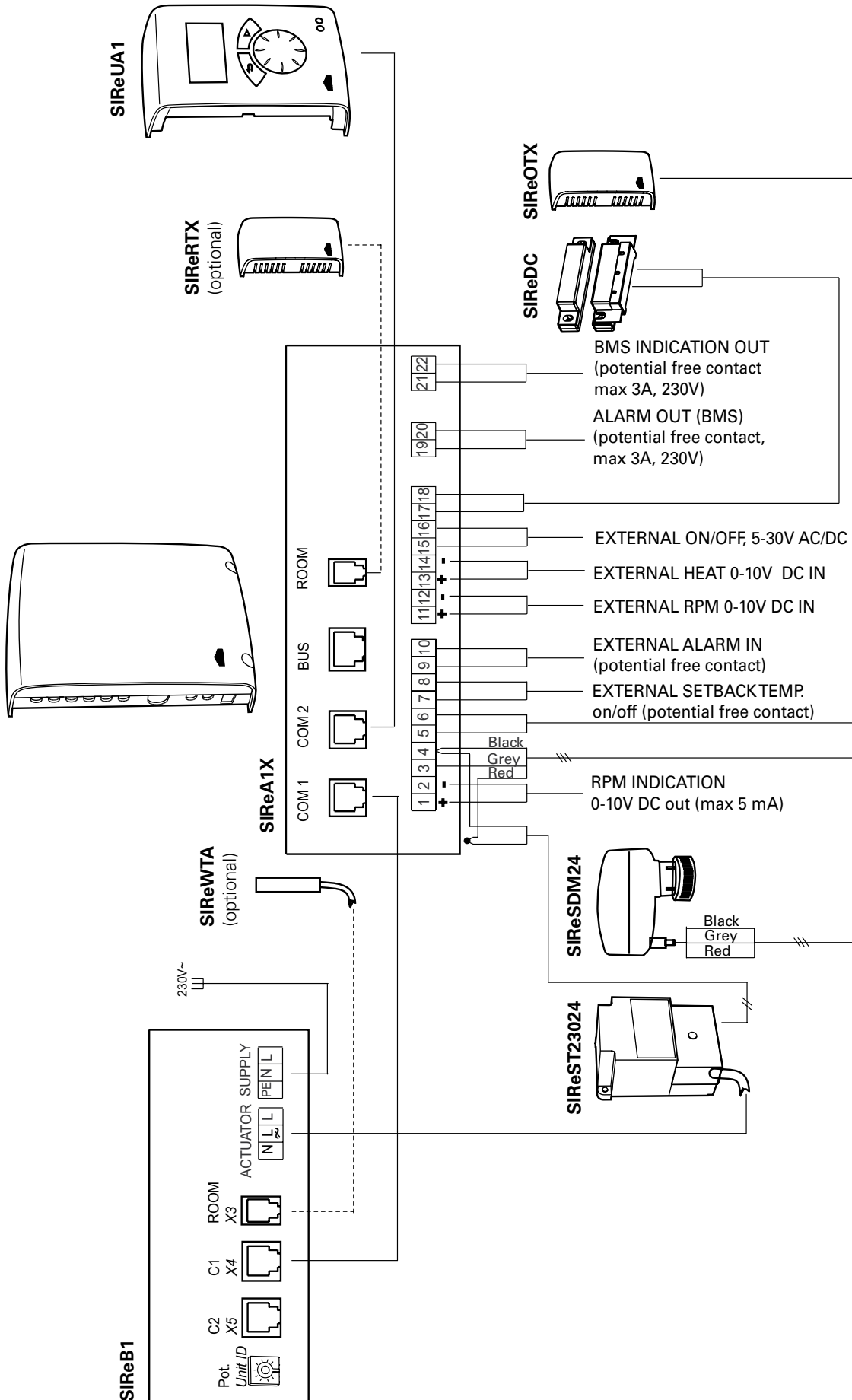

Advanced - parallel

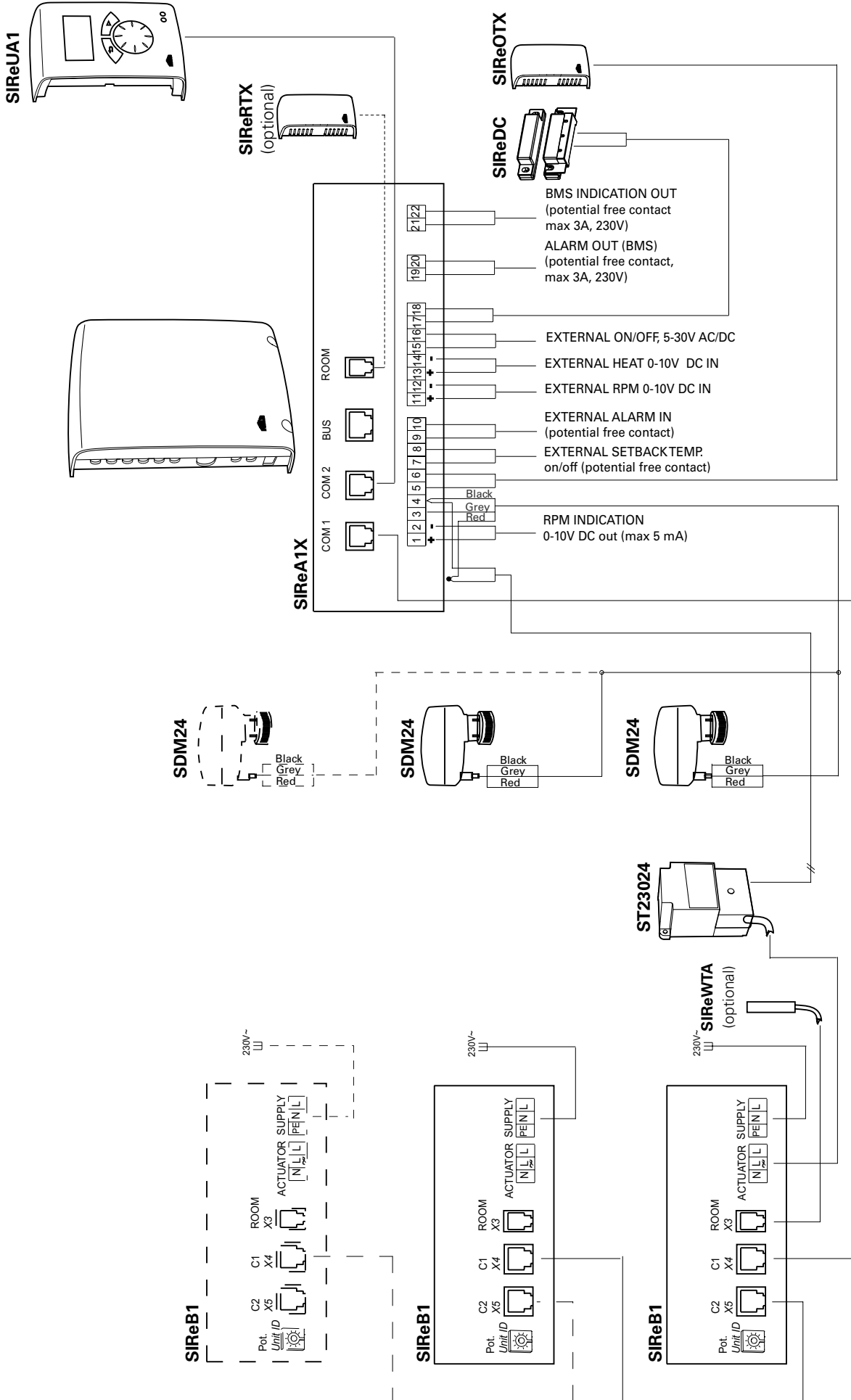

## Thermozone AD Corinte W - ADCS

### AD Corinte W - ADCS Low temperature coil

In- / outlet water temperature 70/40 °C								
			Inlet air temp. +15 °C			Incoming air temp. +20 °C		
Type	Fan position	Airflow [m³/h]	Output [kW]	Air temp. out [°C]	Water flow [l/s]	Output [kW]	Air temp. out [°C]	Water flow [l/s]
<b>ADCS17</b>	max	3000	21.8	36	0.17	18.5	38	0.14
	min	1400	13.5	43	0.10	11.5	44	0.09
<b>ADCS22</b>	max	4000	30.7	37	0.24	26.2	39	0.20
	min	1800	18.4	45	0.14	15.8	45	0.12
<b>ADCS25</b>	max	4500	35.1	38	0.27	30.0	39	0.23
	min	2050	21.2	45	0.16	18.2	46	0.14

Incoming / outgoing water temperature 60/40 °C								
			Incoming air temp. = +15 °C			Incoming air temp. = +20 °C		
Type	Fan position	Airflow [m³/h]	Output [kW]	Air temp. out [°C]	Water flow [l/s]	Output [kW]	Air temp. out [°C]	Water flow [l/s]
<b>ADCS17</b>	max	3000	19.4	34	0.23	16.2	36	0.19
	min	1400	12.0	40	0.14	10.1	41	0.12
<b>ADCS22</b>	max	4000	27.0	35	0.32	22.8	37	0.27
	min	1800	16.1	41	0.19	13.7	42	0.16
<b>ADCS25</b>	max	4500	30.8	35	0.36	26.0	37	0.31
	min	2050	18.5	42	0.22	15.7	43	0.18

Incoming / outgoing water temperature 60/30 °C								
			Incoming air temp. = +15 °C			Incoming air temp. = +20 °C		
Type	Fan position	Airflow [m³/h]	Output [kW]	Air temp. out [°C]	Water flow [l/s]	Output [kW]	Air temp. out [°C]	Water flow [l/s]
<b>ADCS17</b>	max	3000	14.4	29	0.11	10.9	31	0.08
	min	1400	9.2	34	0.07	7.1	35	0.05
<b>ADCS22</b>	max	4000	20.7	30	0.16	15.9	32	0.12
	min	1800	12.8	36	0.10	10.0	36	0.07
<b>ADCS25</b>	max	4500	23.8	31	0.18	18.5	32	0.14
	min	2050	14.8	36	0.11	11.6	37	0.09

Incoming / outgoing water temperature 55/35 °C								
			Incoming air temp. = +15 °C			Incoming air temp. = +20 °C		
Type	Fan position	Airflow [m³/h]	Output [kW]	Air temp. out [°C]	Water flow [l/s]	Output [kW]	Air temp. out [°C]	Water flow [l/s]
<b>ADCS17</b>	max	3000	16.1	31	0.19	12.9	33	0.15
	min	1400	10.0	36	0.11	8.1	37	0.09
<b>ADCS22</b>	max	4000	22.6	32	0.27	18.2	33	0.21
	min	1800	13.6	37	0.16	11.1	38	0.13
<b>ADCS25</b>	max	4500	25.9	32	0.30	21.0	34	0.25
	min	2050	15.7	38	0.18	12.8	38	0.15

## Thermozone AD Corinte W - ADCS

### AD Corinte W - ADCS High temperature coil

In- / outlet water temperature 130/65 °C								
			Inlet air temp. +15 °C			Incoming air temp. +20 °C		
Type	Fan position	Airflow [m³/h]	Output [kW]	Air temp. out [°C]	Water flow [l/s]	Output [kW]	Air temp. out [°C]	Water flow [l/s]
<b>ADCS17</b>	max	3000	30.8	45	0.11	28.6	48	0.10
	min	1400	20.0	57	0.07	18.6	59	0.06
<b>ADCS22</b>	max	4000	42.8	46	0.15	39.7	49	0.14
	min	1800	27.1	59	0.09	25.2	61	0.09
<b>ADCS25</b>	max	4500	48.8	47	0.17	45.3	49	0.16
	min	2050	31.1	59	0.11	29.0	61	0.10

Incoming / outgoing water temperature 90/70 °C								
			Incoming air temp. = +15 °C			Incoming air temp. = +20 °C		
Type	Fan position	Airflow [m³/h]	Output [kW]	Air temp. out [°C]	Water flow [l/s]	Output [kW]	Air temp. out [°C]	Water flow [l/s]
<b>ADCS17</b>	max	3000	26.4	40	0.31	24.3	43	0.28
	min	1400	16.8	50	0.20	15.4	52	0.18
<b>ADCS22</b>	max	4000	36.0	41	0.43	33.1	44	0.39
	min	1800	22.3	51	0.26	20.6	53	0.24
<b>ADCS25</b>	max	4500	40.8	41	0.48	37.6	44	0.44
	min	2050	25.5	51	0.30	23.5	53	0.28

Incoming / outgoing water temperature 82/71 °C								
			Incoming air temp. = +15 °C			Incoming air temp. = +20 °C		
Type	Fan position	Airflow [m³/h]	Output [kW]	Air temp. out [°C]	Water flow [l/s]	Output [kW]	Air temp. out [°C]	Water flow [l/s]
<b>ADCS17</b>	max	3000	25.4	40	0.55	23.3	42	0.50
	min	1400	16.0	48	0.34	14.7	51	0.31
<b>ADCS22</b>	max	4000	34.5	40	0.74	31.7	43	0.68
	min	1800	21.2	49	0.46	19.5	51	0.42
<b>ADCS25</b>	max	4500	39.1	40	0.84	35.9	43	0.77
	min	2050	24.2	49	0.52	22.2	52	0.48

Incoming / outgoing water temperature 80/60 °C								
			Incoming air temp. = +15 °C			Incoming air temp. = +20 °C		
Type	Fan position	Airflow [m³/h]	Output [kW]	Air temp. out [°C]	Water flow [l/s]	Output [kW]	Air temp. out [°C]	Water flow [l/s]
<b>ADCS17</b>	max	3000	22.0	36	0.26	19.9	39	0.23
	min	1400	14.0	44	0.16	12.7	46	0.15
<b>ADCS22</b>	max	4000	30.1	37	0.35	27.3	40	0.32
	min	1800	18.7	45	0.22	17.0	47	0.20
<b>ADCS25</b>	max	4500	34.2	37	0.40	31.0	40	0.36
	min	2050	21.4	45	0.25	19.4	47	0.23

## Thermozone AD Corinte W - ADCS

**Technical specifications** | Thermozone AD Corinte WL with water heat, coil for low tempered water < 80/60 °C ♠

Type	Output* <sup>4</sup>	Airflow	$\Delta t^{*3,4}$	Water volume	Sound level* <sup>5</sup>	Output motor	Voltage motor	Amperage motor	Length	Weight
	[kW]	[m <sup>3</sup> /h]	[°C]	[l]	[dB(A)]	[W]	[V]	[A]	[mm]	[kg]
<b>ADCS17WL</b> * <sup>1</sup>	33	1400/3000	42/32	2,8	39/59	670	230V~	2,9	1700	85
<b>ADCS22WL</b>	46	1800/4000	43/33	3,6	42/60	990	230V~	4,3	2200	110
<b>ADCS25WL</b> * <sup>2</sup>	52	2050/4500	43/34	4,0	42/61	1150	230V~	5,0	2450	125

**Technical specifications** | Thermozone AD Corinte WH with water heat, coil for high tempered water ≥80/60 °C ♠

Type	Output* <sup>4</sup>	Airflow	$\Delta t^{*3,4}$	Water volume	Sound level* <sup>5</sup>	Output motor	Voltage motor	Amperage motor	Length	Weight
	[kW]	[m <sup>3</sup> /h]	[°C]	[l]	[dB(A)]	[W]	[V]	[A]	[mm]	[kg]
<b>ADCS17WH</b> * <sup>1</sup>	22	1400/3000	30/22	2,8	39/59	670	230V~	2,9	1700	85
<b>ADCS22WH</b>	30	1800/4000	31/22	3,6	42/60	990	230V~	4,3	2200	110
<b>ADCS25WH</b> * <sup>2</sup>	34	2050/4500	31/22	4,0	42/61	1150	230V~	5,0	2450	125

\*1) ADCS17 is available only for horizontal mounting.

\*2) ADCS25 is available only for vertical mounting.

\*3) Applicable at water temperature 80/60 °C, air temperature in + 15 °C.

\*4)  $t$  = temperature rise of passing air at maximum heat output and lowest/highest airflow.

\*5) Conditions: Distance to the unit: 5 metres. Directional factor: 2. Equivalent absorption area: 200 m<sup>2</sup>.

Protection class: IP20.

CE compliant.

## Mounting and operating instructions

### General Instructions

Read these instructions carefully before installation and use. Keep this manual for future reference.

*The guarantee is only valid if the units are used in the manner intended by the manufacturer and in accordance with the Frico mounting and operating instructions.*

### Application

The Thermozone AD Corinte W - ADCS air curtain is supplied with a water coil and is intended for permanent installation above or beside entrance doors and other openings up to 3,5 metres in height. Protection class: IP20.

### Operation

Air is drawn in at the top/rear of the unit and blown out downwards/outwards so that it shields the door opening and minimizes heat loss. To achieve the optimum curtain effect the unit must extend the full height/width of the door opening.

The grille for directing exhaust air is adjustable and is normally angled outwards to achieve the best protection against incoming cold air.

The efficiency of the air curtain depends on the air temperature, pressure differences across the doorway and any wind pressure. *NOTE! Negative pressure in the building considerably reduces the efficiency of the air curtain. The ventilation should therefore be balanced.*

### Vertical mounting

The unit is mounted vertically on the floor with the exhaust opening facing outwards.

Before installation, decide whether any electrical connections or water connections are to be made from below.

Leave the protective plastic in place during installation. Take care to avoid damaging the surfaces. For installation see Figure 4.

1. Remove the two screws that secure the intake grille (A) and remove this.
2. Undo the screws holding the front panel (C) on the exhaust side (B).
3. Undo the two screws in the front panel and

remove it.

4. Place the edging in level on the floor and secure it through the countersunk holes (see Fig. 7). Place the air curtain on the edging.
  5. A flat bar is included for securing the air curtain. Fixate the air curtain through the square-shaped hole. Make sure that the flat bar is not bent when fixing.
  6. Secure the top with an angle bracket or similar to prevent the air curtain from toppling over. There is a hole in the centre of the top of the air curtain with an internal M8 thread for securing the bracket.
  7. Hook the front panel (C) onto the edge on the intake side (A), close and press it into the slot on the exhaust side (B).
  8. Fasten the two screws in the front panel.
  9. Secure the front panel on the exhaust side.
  10. Replace the intake grille. (A)
- To remove dirt and finger prints, polish the panels with a suitable cleanser. Any print that may be on the panels is removed with a suitable solvent.

### Horizontal mounting

The unit is mounted horizontally with the outlet facing downwards. Do not remove the protecting plastic until mounting is completed. Be careful so the surfaces are not damaged.

Mounting less than 180 mm from the ceiling is not recommended since it will reduce the flow through the unit.

Two brackets are delivered with the unit for mounting on the wall or hanging from the ceiling.

### Horizontal mounting on the wall

1. Mount the brackets on the wall according to measures in Fig. 6a and 6b.
2. Put the unit in place and lock it with an hexagon key and the included M8 screws.

### Horizontal mounting on the ceiling

1. Mount pendulums or similar (not included on delivery) on the ceiling with c-c distance according to Fig. 6a and 6b.
2. Mount the brackets on the unit with an hexagon key and the included M8 screws.
3. Put the unit in place and fix the brackets to the pendulums.

Note! The unit needs to be secured if hung from wires.

### Electrical installation

The installation, which should be preceded by an omnipolar switch with a contact separation of at least 3 mm, should only be wired by a competent electrician and in accordance with the latest edition of IEE wiring regulations.

The electrical connection may be done from above or below when mounted vertically, and from left or right when mounted horizontally, according to ordering key. Control (230V~) should be connected to a terminal block.

The control system is pre-installed in the aircurtain with an integrated control card, (see fig 8).

SIRe is supplied pre-programmed with quick-release connections.

Modular cables are connected to the control board Base, by opening the front plate, as shown in Figure 4 and 5. See manual for SIRe.

### Connection of water coil

The air curtain has a heating coil with copper tubes suitable for connection to a closed water heating system. The heating coil must not be connected to a mains pressure water system or an open water system.

The unit is connected from above or below to Ø22 mm copperpipes, by compression fitting or through welding the pipe work to the unit.

The upper side of the heating coil is equipped with ventilating valve in the unit. The heating coil should be ventilated before operation to prevent air locks.

When mounting the unit vertically, water connection can be carried out from the top or bottom. The connection from below can be done the following way:

- Flexible hoses may be drawn through drilled holes in the floor and connected to the air curtain pipes. The flexible hoses are connected to the system beneath the floor. Note! At connection from below, avoid placing hoses or pipes so that they obstruct the air flow to the fans. If necessary, secure them to avoid vibrations and prevent them from being sucked into the fans.

When mounting the unit horizontally, water connection can be carried out from the left or right. The lid on the top side of the unit is sliding to be adjustable to the water pipe dimension. (see Fig 6a).

### Adjustment of air flow

The direction and speed of the air flow should be adjusted considering the load on the opening. Compressive forces affect the air stream and make it bend inwards into the premises (when the premises are heated and the outdoor air is cold). The air stream should therefore be directed outwards to withstand the load. (Generally speaking, the higher the load, the bigger the angle needed.)

With an hexagon key, loosen the three screws supporting the outlet grille. Angle the grille outwards to obstruct the incoming cold air.

### Overheating

The over heat protection maintains the exhaust temperature at +40 °C. If the temperature should exceed anyway there is an over heating alarm. For more information see the manual for SIRe.

### Maintenance

To ensure performance and reliability of the air curtain inspection should be carried out regularly, at least twice a year, but this can vary depending on local conditions. This is to secure the performance of the air curtain.

A clogged filter doesn't present a risk, but will reduce the efficiency of the air curtain.

The inlet grille works as a filter and should be vacuumed regularly. The water battery should be cleaned when necessary in the following way:

1. Disconnect the power supply.

2. Loosen the two screws of the air intake grille with a hexagon key and remove the grille.
3. Carefully wipe the fins of the heating coil with a wet cloth.
5. Remount the air intake grille.
6. Connect the power.

Filter cassettes, that the unit may be equipped with, cannot be cleaned but need to be changed when they are soiled or when the airflow is reduced. The basic filter is cleaned with water and a gentle cleaning agent.

Since fan motors and other components are maintenance free, no maintenance other than cleaning is necessary, undertake cleaning at least twice a year.

### **Safety**

- *Ensure that the area around the intake and exhaust grille is kept free from material which could prevent the air to flow through the unit!*
- *During operation the surfaces of the unit are hot!*
- *This appliance is not intended for use by persons (including children) with reduced physical or mental capabilities, or lack of experience and knowledge, unless they have been given supervision or instruction concerning use of the appliance by a person responsible for their safety. Children should be supervised to ensure that they do not play with the appliance.*



**Main office**

Frico AB  
Box 102  
SE-433 22 Partille  
Sweden

Tel: +46 31 336 86 00  
Fax: +46 31 26 28 25  
mailbox@frico.se  
www.frico.se

**For latest updated information and information  
about your local contact: [www.frico.se](http://www.frico.se)**