

Original instructions
AR3500

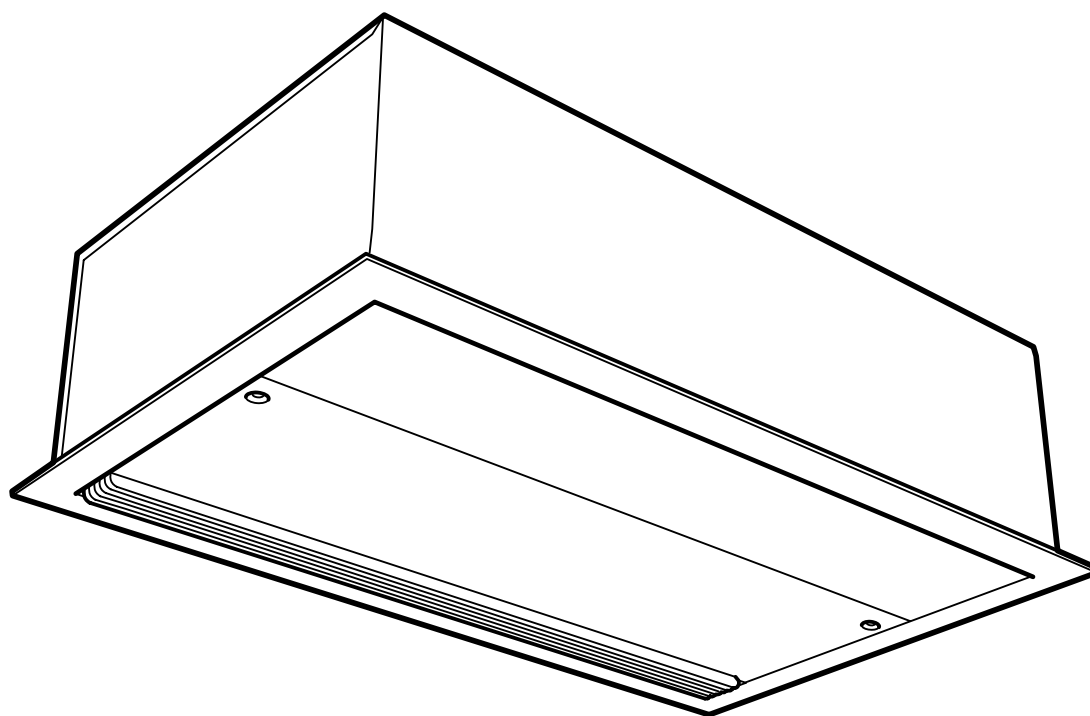

SE ... 14

GB ... 19

NO ... 23

FI ... 28

FR ... 33

DE ... 38

RU ... 43

PL ... 48

IT ... 53

NL ... 58

ES ... 63

HU ... 68

- SE** Introduktionssidorna består huvudsakligen av bilder. För översättning av de engelska texter som används, se respektive språksidor.
- GB** The introduction pages consist mainly of pictures. For translation of the English texts used, see the respective language pages.
- NO** Introduksjonssidene består hovedsakelig av bilder. For oversettelse av de engelske tekstene, se de respektive språksidene
- FR** Les pages de présentation contiennent principalement des images. Consulter la page correspondant à la langue souhaitée.
- DE** Die Einleitungsseiten bestehen hauptsächlich aus Bildern. Für die Übersetzung der verwendeten Texte in englischer Sprache, siehe die entsprechenden Sprachseiten.
- ES** Las páginas introductorias contienen básicamente imágenes. Consulte la traducción de los textos en inglés que las acompañan en las páginas del idioma correspondiente.
- NL** De inleidende pagina's bevatten hoofdzakelijk afbeeldingen. Voor een vertaling van de gebruikte Engelse teksten, zie de pagina's van de resp. taal.
- IT** Le pagine introduttive contengono prevalentemente immagini. Per le traduzioni dei testi scritti in inglese, vedere le pagine nelle diverse lingue.
- PL** Początkowe strony zawierają głównie rysunki. Tłumaczenie wykorzystanych tekstów angielskich znajduje się na odpowiednich stronach językowych.
- RU** Страницы в начале Инструкции состоят в основном из рисунков, схем и таблиц. Перевод встречающегося там текста приведен в разделе RU.

AR3500

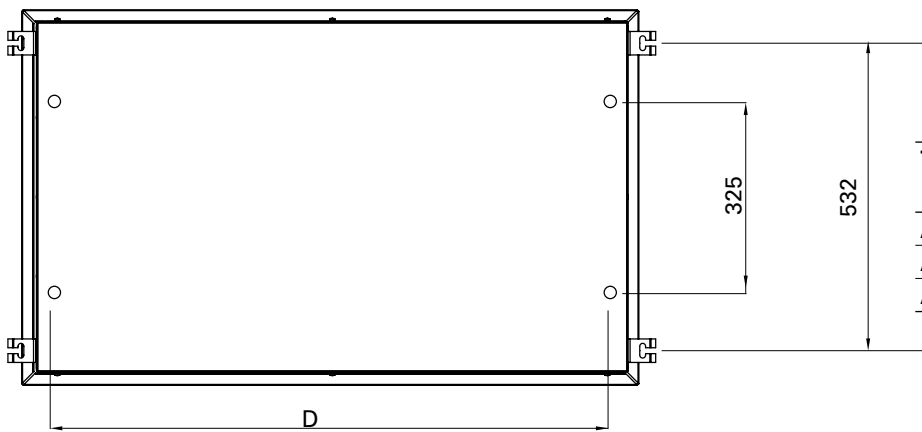
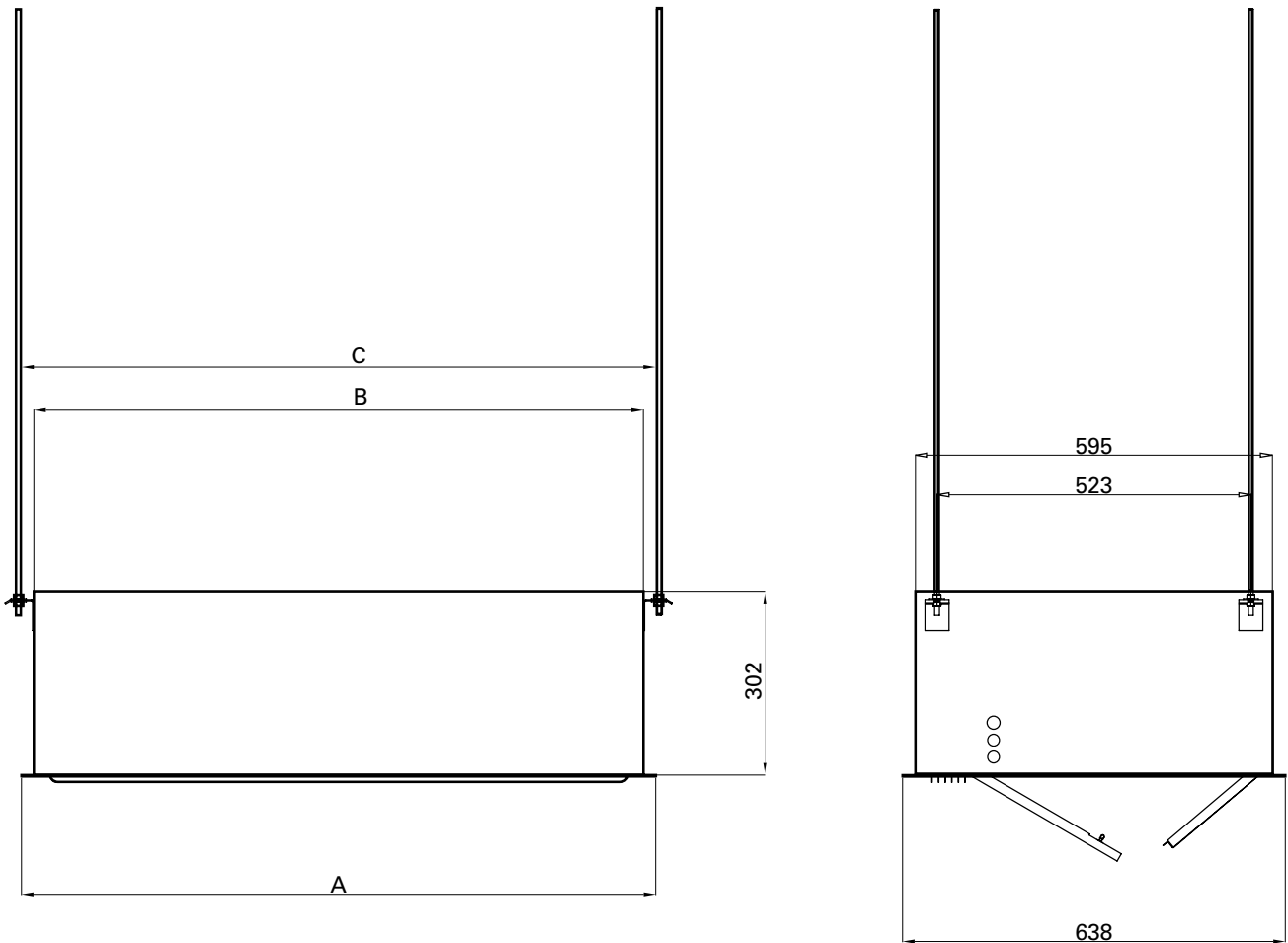

Type	A	B	C	D
	[mm]	[mm]	[mm]	[mm]
AR3510	1057	1016	1067	956
AR3515	1567	1526	1577	1466
AR3520	2073	2031	2083	1971

Mounting

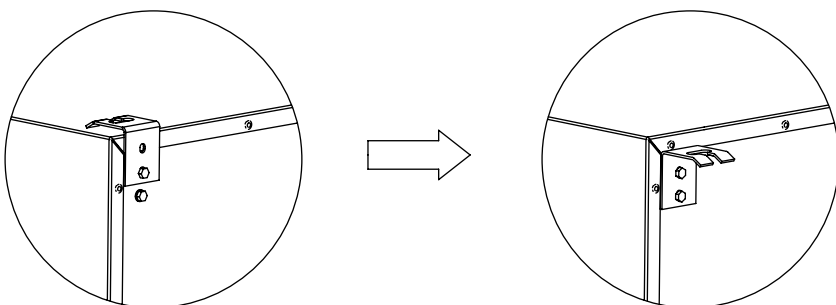

Fig. 1: The mounting brackets on delivery.

Mounting

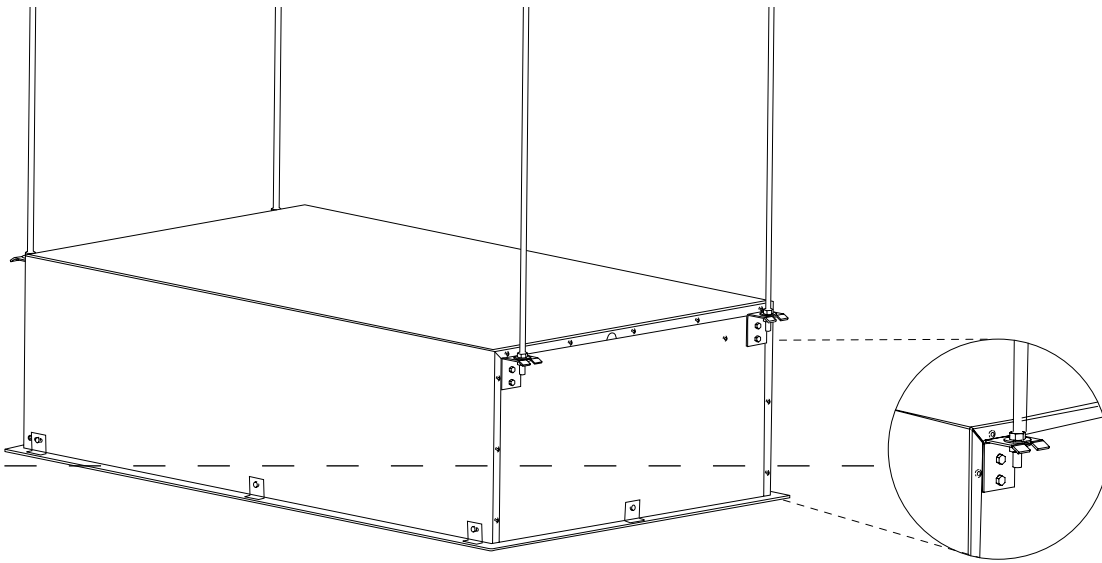

Fig. 2a: Mounting on threaded bars.

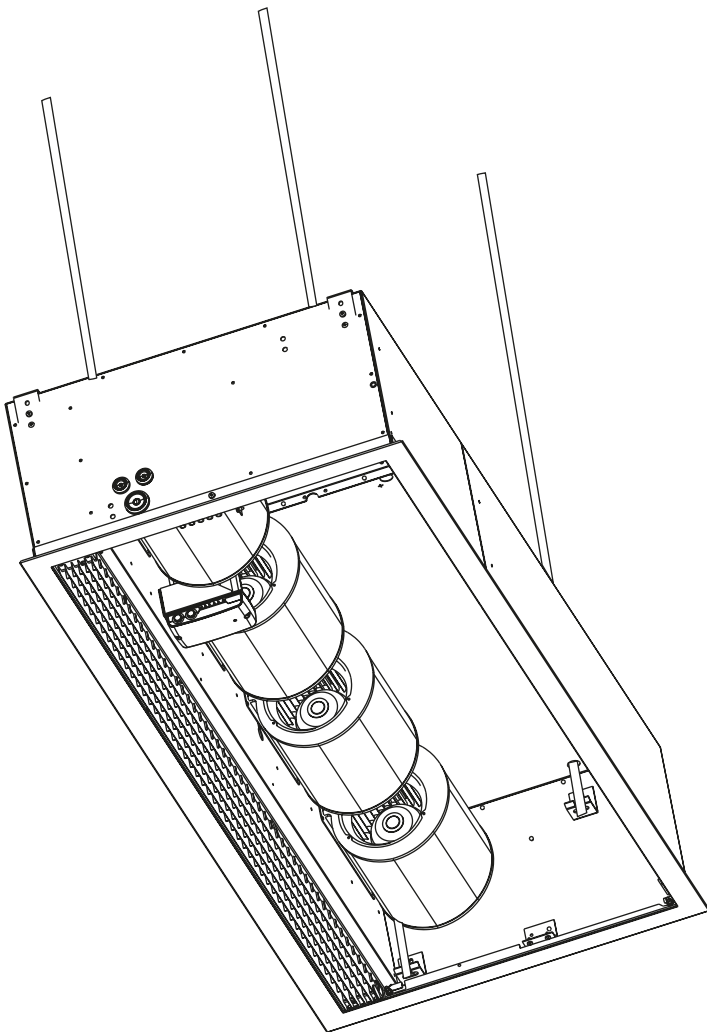

Fig. 2b: Mounting on threaded bars inside unit.

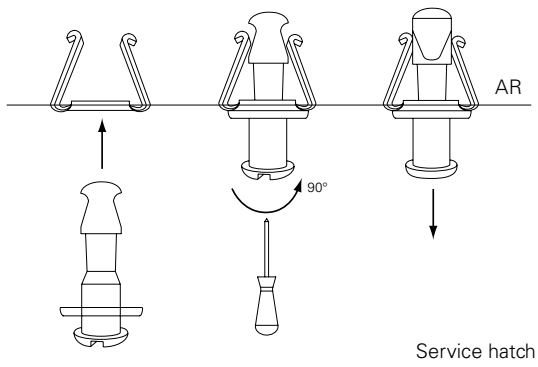

Fig. 3: Function of the snap fixing

Water connections

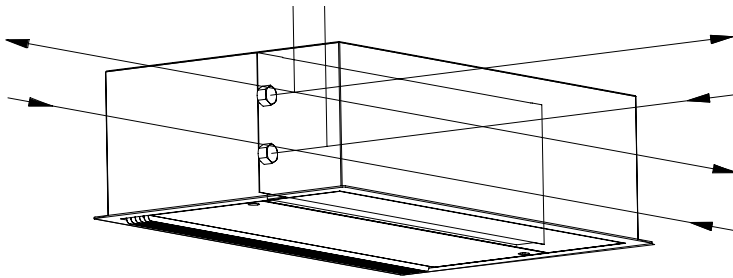

Fig. 4: The water coil is connected inside the unit through holes which are made (during installation) on the upper side or through the side of the unit, possible places are marked with punch marks.

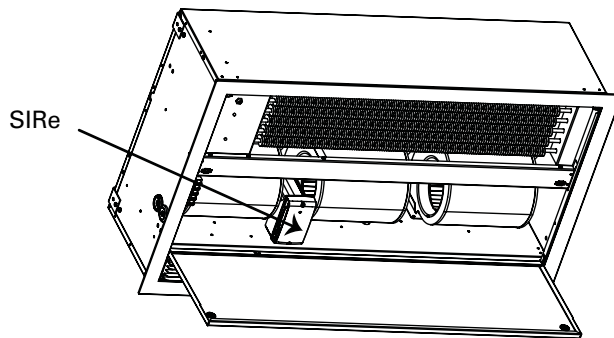
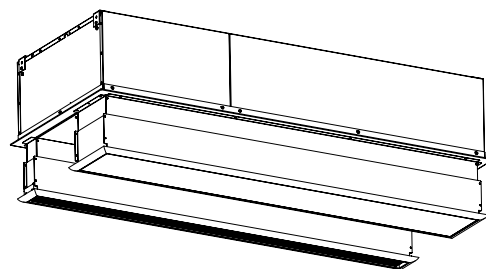

Fig. 5: SIRe inside unit.

Accessories

Type	L [mm]
AR35XTT10	130-210
AR35XTT15	130-210
AR35XTT20	130-210



See separate manual for AR35XTT

Accessories

SIRe

SIReB	
SIReAC	
SIReAA	
SIReRTX	70x33x23 mm
SIReUR	114x70x50 mm
SIReWTA	
SIReCJ4	
SIReCJ6	
SIReCC603	3 m
SIReCC605	5 m
SIReCC610	10 m
SIReCC615	15 m
SIReCC640	40 m
SIReCC403	3 m
SIReCC405	5 m
SIReCC410	10 m
SIReCC415	15

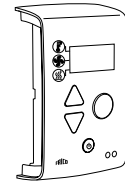

SIReB

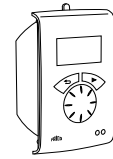

SIReUR

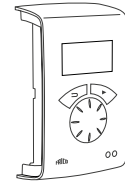

SIReAC/SIReAA

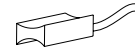

SIReWTA

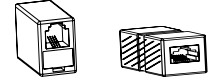

SIReCJ4/SIReCJ6



SIReRTX

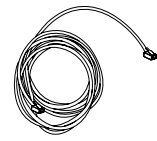

SIReCC



VMO15LF	DN15
VMO15NF	DN15
VMO20	DN20
VMO25	DN25
VMOP15LF	DN15
VMOP15NF	DN15
VMOP20	DN20
VMOP25	DN25
VOS15LF	DN15
VOS15NF	DN15
VOS20	DN20
VOS25	DN25
VOSP15 LF	DN15
VOSP15NF	DN15
VOSP20	DN20
VOSP25	DN25
VOT15	DN15
VOT20	DN20
VOT25	DN25
VMT15	DN15
VMT20	DN20
VMT25	DN25
VAT	

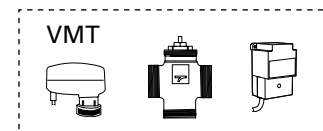
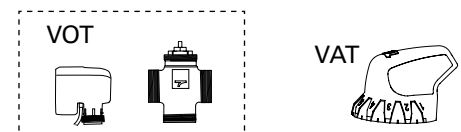
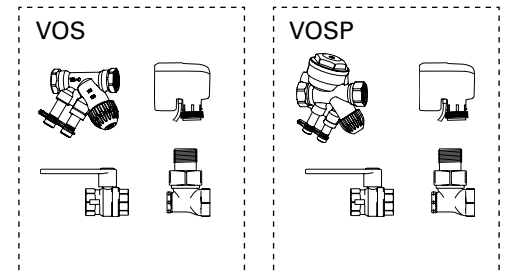
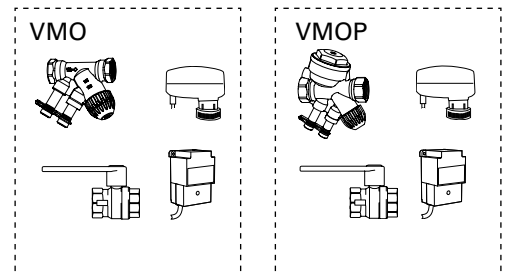

AR3500 A
AR3500 W

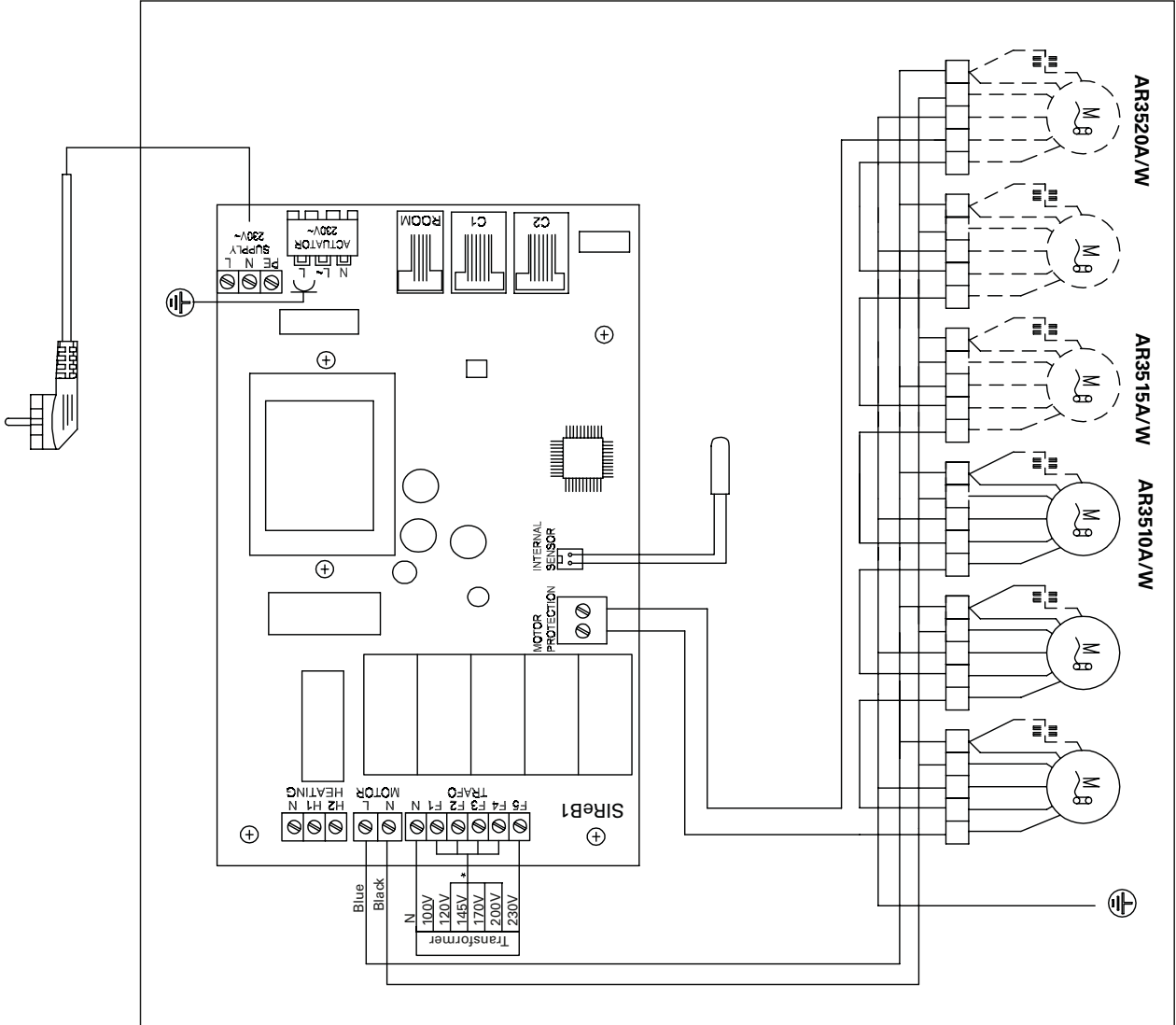

AR3500 E

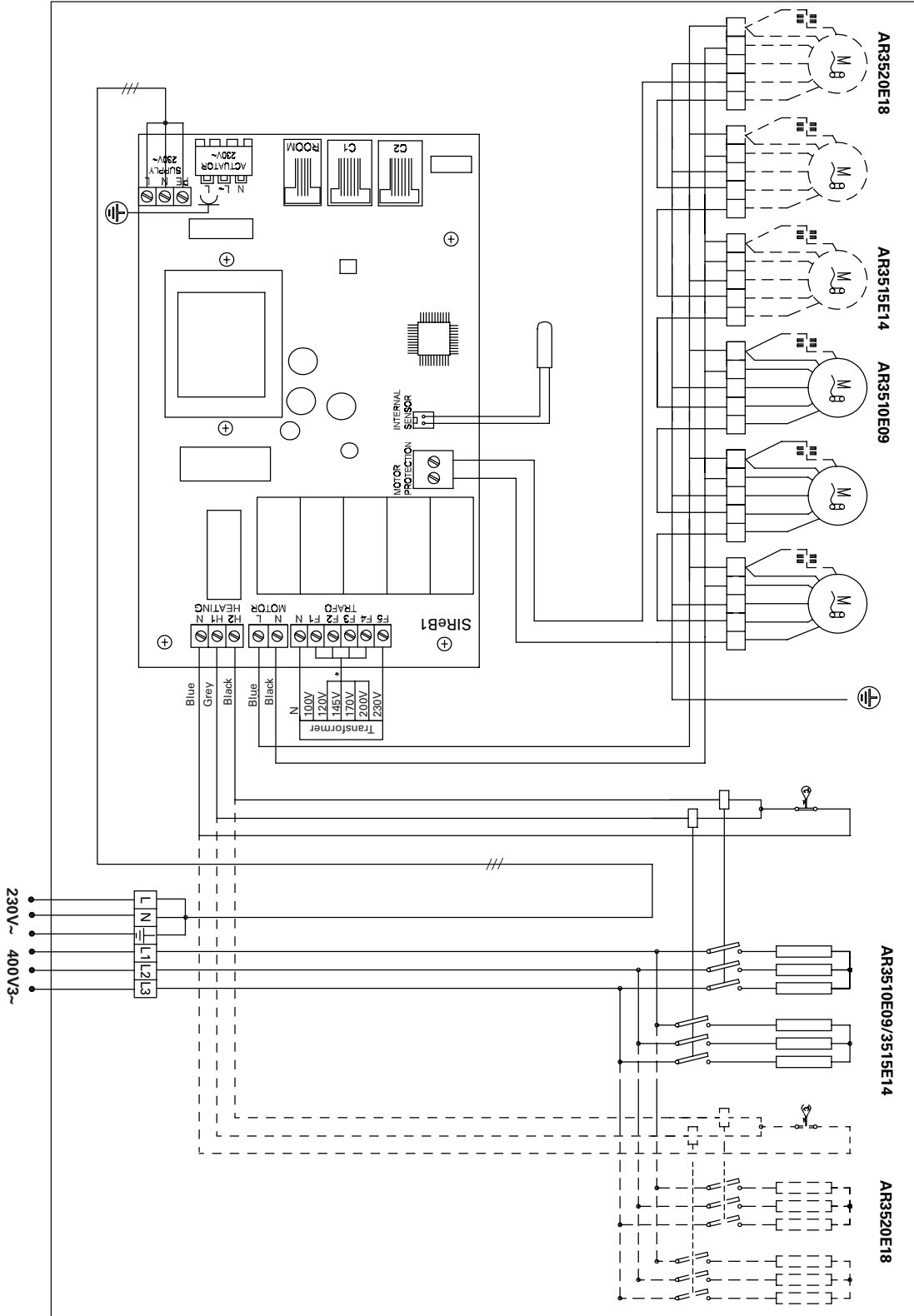

SIReB Basic

AR3500 A / AR3500 E

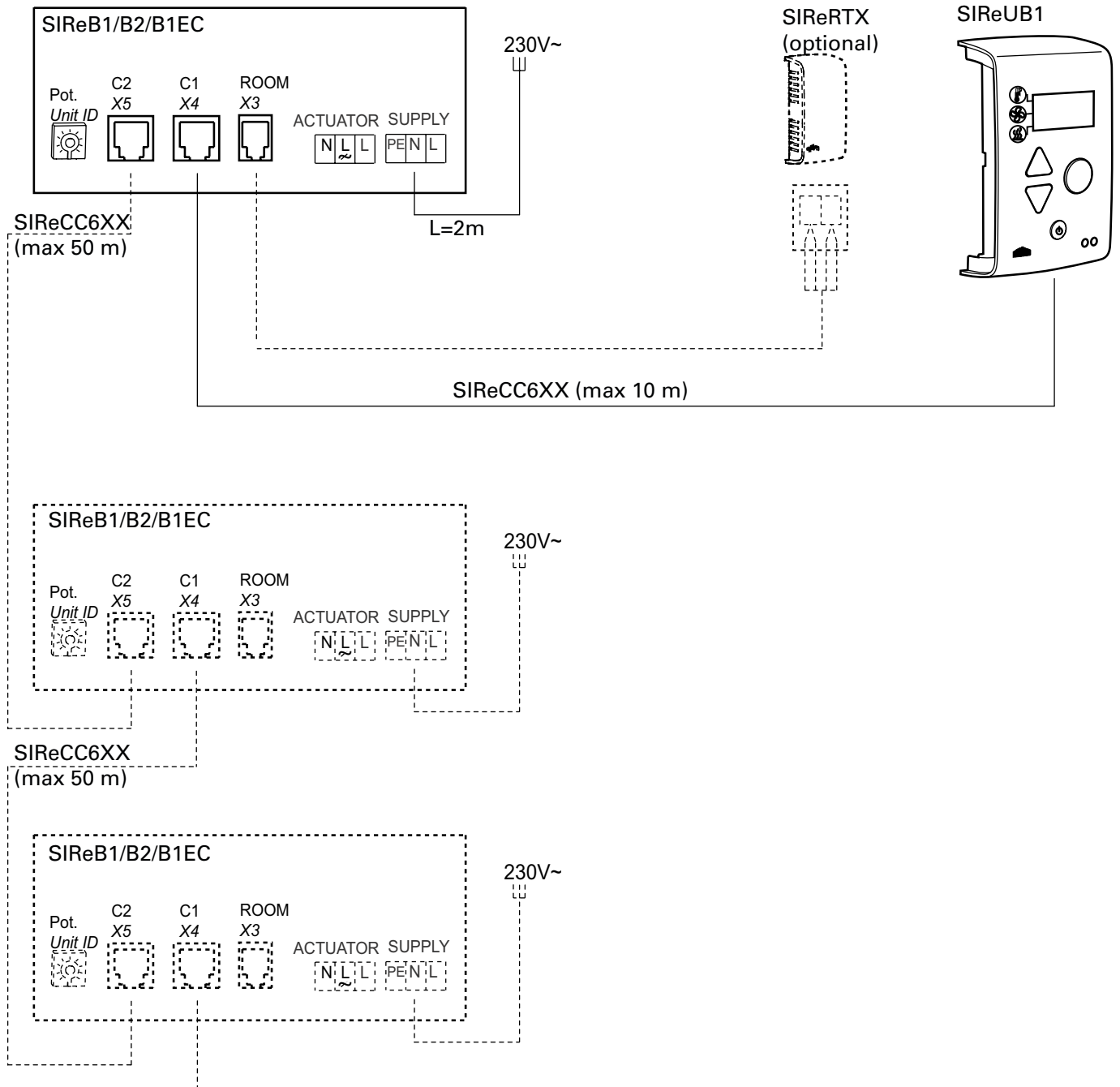

Wiring diagrams for SIReAC Competent, see manual for SIRe.

SIReB Basic

AR3500 W

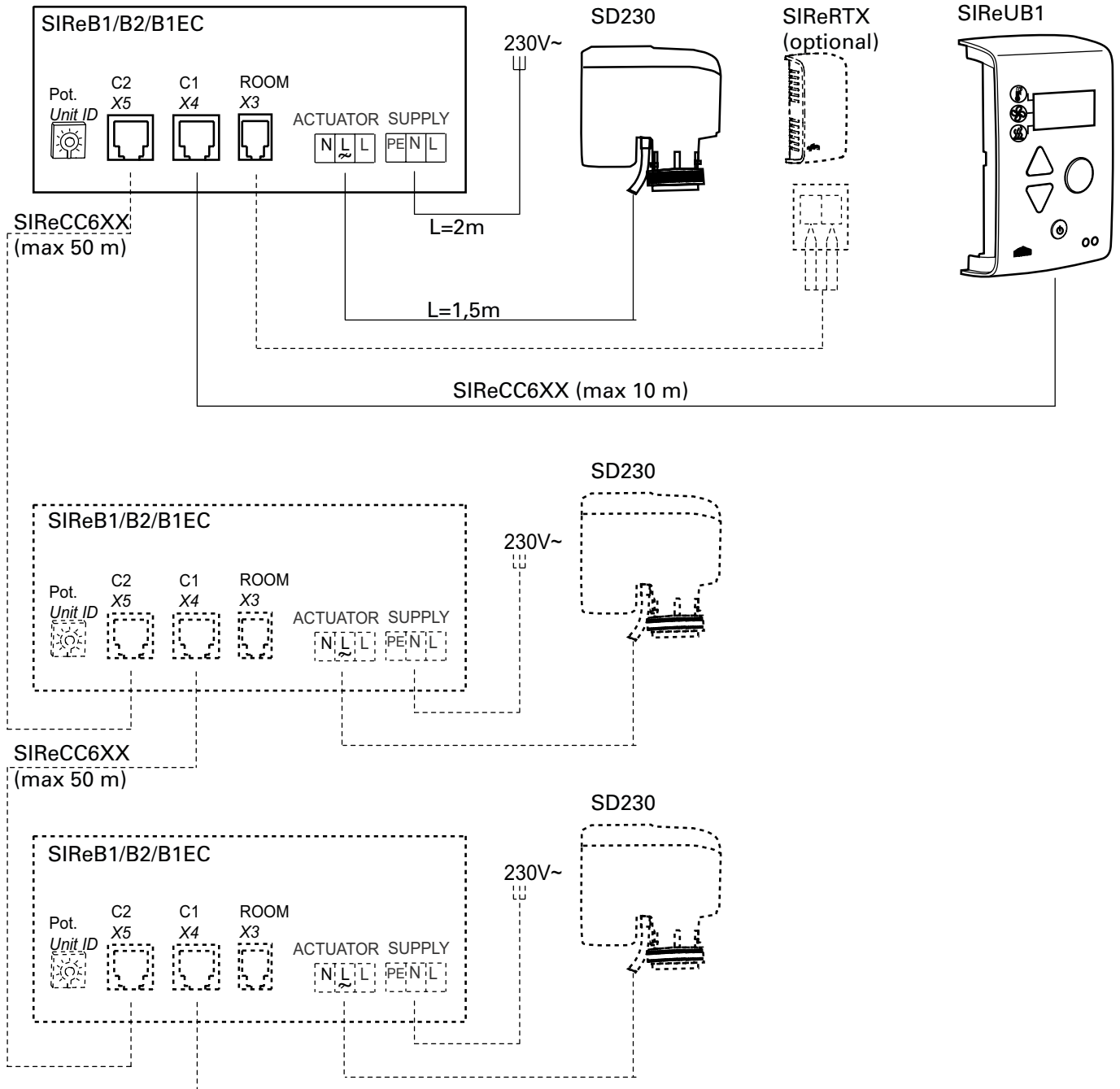

Wiring diagrams for SIReAC Competent and SIReAA Advanced, see manuals for SIRe.

AR3500

Output charts water AR3500

AR3500W Standard coil

			Supply water temperature: 80 °C Room temperature: +18 °C Outlet air temperature: +35 °C*1				Water temperature: 80/60 °C Room temperature: +18 °C			
Type	Fan position	Airflow [m³/h]	Output [kW]	Return water temp. [°C]	Water flow [l/s]	Pressure drop [kPa]	Output *2 [kW]	Outlet air temp. [°C]	Water flow [l/s]	Pressure drop [kPa]
AR3510W	max	2000	11,5	44,5	0,08	2,0	14,9	40,1	0,18	11,0
	min	1000	5,7	33,6	0,03	0,6	9,6	46,4	0,12	5,0
AR3515W	max	2800	16,0	42,2	0,10	2,0	21,9	41,2	0,27	9,0
	min	1400	8,0	32,4	0,04	0,4	14,0	47,5	0,17	4,0
AR3520W	max	4000	23,0	41,0	0,14	4,0	31,4	41,3	0,37	19,0
	min	2000	11,5	31,0	0,06	1,0	20,0	47,7	0,24	9,0

			Supply water temperature: 70 °C Room temperature: +18 °C Outlet air temperature: +35 °C*1				Water temperature: 70/50 °C Room temperature: +18 °C			
Type	Fan position	Airflow [m³/h]	Output [kW]	Return water temp. [°C]	Water flow [l/s]	Pressure drop [kPa]	Output *2 [kW]	Outlet air temp. [°C]	Water flow [l/s]	Pressure drop [kPa]
AR3510W	max	2000	11,5	48,7	0,13	6,0	11,5	35,4	0,14	7,0
	min	1000	5,7	37,0	0,04	1,0	7,6	40,5	0,09	3,0
AR3515W	max	2800	16,0	46,2	0,16	4,0	17,3	36,3	0,21	6,0
	min	1400	8,0	35,5	0,06	1,0	11,1	41,4	0,13	3,0
AR3520W	max	4000	23,0	45,5	0,22	8,0	24,9	36,5	0,29	14,0
	min	2000	11,5	34,4	0,08	1,0	15,9	41,6	0,19	6,0

			Supply water temperature: 60 °C Room temperature: +18 °C Outlet air temperature: +35 °C*1				Water temperature: 60/40 °C Room temperature: +18 °C			
Type	Fan position	Airflow [m³/h]	Output [kW]	Return water temp. [°C]	Water flow [l/s]	Pressure drop [kPa]	Output *2 [kW]	Outlet air temp. [°C]	Water flow [l/s]	Pressure drop [kPa]
AR3510W	max	2000	11,5	53,7	0,44	53,0	8,6	30,7	0,10	4,0
	min	1000	5,7	41,2	0,08	2,0	5,6	34,5	0,07	2,0
AR3515W	max	2800	16,0	51,0	0,43	20,0	12,6	31,3	0,15	3,0
	min	1400	8,0	39,6	0,09	1,0	8,1	35,2	0,10	1,0
AR3520W	max	4000	23,0	51,2	0,63	46,0	18,3	31,6	0,22	8,0
	min	2000	11,5	38,8	0,13	3,0	11,8	35,5	0,14	4,0

			Supply water temperature: 55 °C Room temperature: +18 °C Outlet air temperature: +35 °C*1				Water temperature: 55/35 °C Room temperature: +18 °C			
Type	Fan position	Airflow [m³/h]	Output [kW]	Return water temp. [°C]	Water flow [l/s]	Pressure drop [kPa]	Output *2 [kW]	Outlet air temp. [°C]	Water flow [l/s]	Pressure drop [kPa]
AR3510W	max	2000	-	-	-	-	6,9	28,3	0,08	3,0
	min	1000	5,7	44,0	0,13	6,0	4,5	31,4	0,06	1,0
AR3515W	max	2800	-	-	-	-	10,2	28,8	0,12	2,0
	min	1400	8,0	42,2	0,15	3,0	6,6	32,0	0,08	1,0
AR3520W	max	4000	-	-	-	-	15,0	29,1	0,18	6,0
	min	2000	11,5	41,7	0,21	7,0	9,7	32,4	0,12	3,0

Output charts water AR3500

AR3500WLL Special coil

			Supply water temperature: 55 °C Room temperature: +18 °C Outlet air temperature: +35 °C*1				Water temperature: 55/35 °C Room temperature: +18 °C			
Type	Fan position	Airflow [m³/h]	Output [kW]	Return water temp. [°C]	Water flow [l/s]	Pressure drop [kPa]	Output *2 [kW]	Outlet air temp. [°C]	Water flow [l/s]	Pressure drop [kPa]
AR3510WLL	max	1900	9,0	26,8	0,08	1,0	12,5	37,5	0,15	3,0
	min	950	4,5	23,4	0,03	0,3	7,6	41,6	0,09	1,0
AR3515WLL	max	2600	12,3	25,1	0,10	1,0	18,4	39,0	0,22	4,0
	min	1300	6,1	22,1	0,04	0,3	11,0	43,0	0,13	2,0
AR3520WLL	max	3800	18,0	25,5	0,15	1,0	26,4	38,6	0,32	4,0
	min	1900	9,0	22,3	0,07	0,4	15,8	42,6	0,19	2,0

			Supply water temperature: 50 °C Room temperature: +18 °C Outlet air temperature: +35 °C*1				Water temperature: 50/30 °C Room temperature: +18 °C			
Type	Fan position	Airflow [m³/h]	Output [kW]	Return water temp. [°C]	Water flow [l/s]	Pressure drop [kPa]	Output *2 [kW]	Outlet air temp. [°C]	Water flow [l/s]	Pressure drop [kPa]
AR3510WLL	max	1900	9,0	28,3	0,10	1,0	9,7	33,1	0,12	2,0
	min	950	4,5	24,5	0,04	0,4	5,9	36,5	0,07	1,0
AR3515WLL	max	2600	12,3	26,6	0,13	1,0	14,4	34,4	0,17	3,0
	min	1300	6,1	23,2	0,06	0,4	8,7	37,8	0,11	1,0
AR3520WLL	max	3800	18,0	27,0	0,19	2,0	20,6	34,1	0,25	3,0
	min	1900	9,0	22,3	0,07	0,4	12,5	37,5	0,15	1,0

			Supply water temperature: 45 °C Room temperature: +18 °C Outlet air temperature: +35 °C*1				Water temperature: 45/35 °C Room temperature: +18 °C			
Type	Fan position	Airflow [m³/h]	Output [kW]	Return water temp. [°C]	Water flow [l/s]	Pressure drop [kPa]	Output *2 [kW]	Outlet air temp. [°C]	Water flow [l/s]	Pressure drop [kPa]
AR3510WLL	max	1900	8,9	30,2	0,14	3,0	10,6	34,6	0,26	7,0
	min	950	4,5	26,0	0,06	0,3	6,3	37,6	0,15	3,0
AR3515WLL	max	2600	12,3	28,5	0,18	3,0	15,4	35,5	0,37	9,0
	min	1300	6,1	24,7	0,07	1,0	9,0	38,4	0,22	4,0
AR3520WLL	max	3800	18,0	29,0	0,27	4,0	22,1	35,2	0,53	9,0
	min	1900	9,0	25,0	0,11	1,0	12,9	38,2	0,31	5,0

			Supply water temperature: 40 °C Room temperature: +18 °C Outlet air temperature: +35 °C*1				Water temperature: 40/30 °C Room temperature: +18 °C			
Type	Fan position	Airflow [m³/h]	Output [kW]	Return water temp. [°C]	Water flow [l/s]	Pressure drop [kPa]	Output *2 [kW]	Outlet air temp. [°C]	Water flow [l/s]	Pressure drop [kPa]
AR3510WLL	max	1900	9,0	33,0	0,31	10,0	8,0	30,4	0,19	5,0
	min	950	4,5	28,4	0,09	1,0	4,8	32,9	0,11	2,0
AR3515WLL	max	2600	12,3	31,4	0,34	8,0	11,7	31,3	0,28	6,0
	min	1300	6,1	27,0	0,11	1,0	6,9	33,7	0,17	2,0
AR3520WLL	max	3800	18,0	31,9	0,53	9,0	16,7	31,1	0,40	6,0
	min	1900	9,0	27,4	0,17	2,0	9,9	33,5	0,24	3,0

AR3500

Technical specifications | AR3500 A without heat ✨

Type	Output [kW]	Airflow [m ³ /h]	Sound level* ¹ [dB(A)]	Voltage Amperage (control)	Length [mm]	Weight [kg]
AR3510A	0	1000/2100	39/58	230 V~/2,6 A	1057	38
AR3515A	0	1400/2900	40/59	230 V~/3,5 A	1567	51
AR3520A	0	2000/4200	41/61	230 V~/5,3 A	2073	70

Technical specifications | AR3500 E electrically heated ⚡

Type	Output steps [kW]	Airflow [m ³ /h]	Δt^{*2} [°C]	Sound level* ¹ [dB(A)]	Voltage Amperage (control)	Voltage Amperage (heat)	Length [mm]	Weight [kg]
AR3510E09	4,5/9	1000/2100	27/13	39/58	230 V~/2,8 A	400 V3~/13 A	1057	42
AR3515E14	7/13,5	1400/2900	29/14	40/59	230 V~/3,6 A	400 V3~/19,5 A	1567	58
AR3520E18	9/18	2000/4200	27/15	41/61	230 V~/5,5 A	400 V3~/26 A	2073	78

Technical specifications | AR3500 W water heated (≤ 80 °C) 💧

Type	Output* ³ [kW]	Airflow [m ³ /h]	$\Delta t^{*2,3}$ [°C]	Sound level* ¹ [dB(A)]	Voltage [V]	Amperage [A]	Length [mm]	Weight [kg]
AR3510W	8,6	1000/2000	17/13	39/58	230V~	2,6	1057	42
AR3515W	12,6	1400/2800	17/13	40/58	230V~	3,6	1567	58
AR3520W	18,3	2000/4000	18/14	41/60	230V~	5,2	2073	78

Technical specifications | AR3500 WLL water heated, coil for low temperature water (≤ 60 °C) 💧

Type	Output* ⁴ [kW]	Airflow [m ³ /h]	$\Delta t^{*2,4}$ [°C]	Sound level* ¹ [dB(A)]	Voltage [V]	Amperage [A]	Length [mm]	Weight [kg]
AR3510WLL	8,0	950/1900	15/12	37/57	230V~	2,7	1057	45
AR3515WLL	11,7	1300/2600	16/13	38/57	230V~	3,6	1567	61
AR3520WLL	16,7	1900/3800	16/13	40/59	230V~	5,2	2073	83

*1) Conditions: Distance to the unit 5 metres. Directional factor: 2. Equivalent absorption area: 200 m². At lowest/highest airflow.

*2) Δt = temperature rise of passing air at maximum heat output and lowest/highest airflow.

*3) Applicable at water temperature 60/40°C, air temperature, in +18 °C.

*4) Applicable at water temperature 40/30 °C, air temperature, in +18 °C.

Protection class: recessed mounting: above false ceiling: IP44, below false ceiling: IP20.

Approved by SEMKO and CE compliant.

Assembly and operating instructions

General Instructions

Read these instructions carefully before installation and use. Keep this manual for future reference.

The guarantee is only valid if the units are used in the manner intended by the manufacturer and in accordance with the Frico mounting and operating instructions.

Application area

The AR3500 air curtain unit is supplied without heat, with electrical heating or hot water coil and is intended for installation above entrances and smaller doors up to 3.5 metres in height.

AR3500 is recessed in false ceilings above entrances.

Protection class above false ceiling: IP44,
below false ceiling: IP20

Operation

Air is drawn in from underneath and blown out downwards towards the entrance so that it shields the door opening and minimises heat loss. To get the best curtain effect the unit must extend the full width of the door opening.

The grille for directing exhaust air is adjustable and is normally angled outwards to achieve the best protection against incoming cold air.

The air speed is adjusted to the desired airflow.

The efficiency of the air curtain(s) depends on the air temperature, pressure differences across the doorway and any wind pressure.

NOTE! Negative pressure in the building considerably reduces the efficiency of the air curtain. The ventilation should therefore be balanced!

Installation

The air curtain is installed horizontally with the supply air grille facing downwards as close to the door as possible, concealed in the false ceiling.

The only visible part of the unit is the underside which is level with the ceiling. The service hatch must be accessible, nothing

should prevent it being fully opened.

The unit is ready for suspension with threaded rods on its outside. The threaded rods can also be fixed on the inside of the unit e.g. when mounted on a solid suspended ceiling.

For the protection of wider doorways, several units can be mounted next to each other.

Minimum distance from outlet to floor for electrically heated units is 1800 mm.

1. The mounting brackets (4x) are fixed to the unit during transport. Slacken these off, turn them around and screw into place on the unit according to figure 1.
2. Hang up on threaded bars (M8) according to figure 2a (not included).
3. Adjust the height using the lower nut so that the frame is on the level of the ceiling. Lock using the upper nut.

Mounting on threaded bars inside unit.

1. The mounting brackets (4x) are fixed to the unit during transport. Loosen them and screw them into place inside the unit in the intended holes.
2. Hang up on threaded bars (M8) according to figure 2b (not included). Note that the brackets are at different heights and threaded rods shall be of different lengths.
3. Adjust the height using the lower nut so that the frame is on the level of the ceiling. Lock using the upper nut.

Electrical installation

The installation, which should be preceded by an omnipolar switch with a contact separation of at least 3 mm, should only be wired by a competent electrician and in accordance with the latest edition of IEE wiring regulations.

The control system is pre-installed in the aircurtain with an integrated control card, (see fig 5).

SIRe is supplied pre-programmed with quick-release connections.

Modular cables are connected to the control board Base, by opening the service hatch, as shown in fig. 3 and 5. See manual for SIRe.

1. The service hatch is opened by loosening the snap fixings located on the down side (turn 90°). See fig. 3.
2. AR3500A: The unit is fitted with cable and plug.
AR3500W: The unit is fitted with cable and plug.
AR3500E: The unit is supplied through cable glands on the side of the unit. For units with electrical heating, power and control should be supplied separately. Control (230V~) and power supply for heat (400V3~) should be connected to a terminal block in the terminal box. The largest cable diameter for the terminal block is 16 mm². The cable glands used must meet the protection class requirements. In the distribution board it is to be indicated that "the air curtains can be supplied from more than one connection".
3. Close the service hatch and make sure that the snap fixings lock properly.

See wiring diagrams.

Type	Output [kW]	Voltage [V]	Minimum area [mm ²]
Manouver	0	230V~	1,5
AR3510E	9	400V3~	2,5
AR3515E	13,5	400V3~	4
AR3520E	18	400V3~	10

Start-up (E)

When the unit is used for the first time or after a long period of disuse, smoke or odour may result from dust or dirt that has collected on the element. This is completely normal and disappears after a short time.

Connecting the water coil (W)

The installation must be carried out by an authorised installer.

The water coil has copper tubes with aluminium fins and is suitable for connection to a closed water heating system. The heating coil must not be connected to a mains pressure water system or an open water system.

Note that the unit shall be preceded by a regulating valve, see Frico valve kit.

To access the connections (DN20, 3/4",

inside thread) the service hatch and intake grille must be opened. The water coil is connected inside the unit through holes which are made (during installation) on the upper side or through the side of the unit, possible places are marked with punch marks.

The connections to the heating coil must be equipped with shut off valves to allow problem free removal.

NOTE: Care must be taken when connecting the pipes. Use a wrench or similar to hold the air curtain connections to prevent straining of the pipes and subsequent water leakage during connection to water supply pipe-work.

See fig. 4.

Adjustment of the air curtain and air flow

The direction and speed of the air flow should be adjusted considering the load on the opening. Pressure forces affect the air stream and make it bend inwards into the premises (when the premises are heated and the outdoor air is cold).

The air stream should therefore be directed outwards to withstand the load. Generally speaking, the higher the load, the greater the angle that is needed.

Basic setting fan speed

The fan speed when the door is open is set using the speed control. Note that the air flow direction and speed may need fine adjustment depending on the loading of the door.

Filter (W)

The heat coil fin distance, in combination with the hole diameter of the intake grille, protects against dirt and blockage and makes a separate filter unnecessary.

Service, repairs and maintenance

For all service, repair and maintenance first carry out the following:

1. Disconnect the power supply.
2. The service hatch is opened by loosening the snap fixings located on the down side (turn 90°). See fig. 3.
3. After service, repairs and maintenance close the service hatch and make sure that the snap fixings lock properly.

Maintenance

Since fan motors and other components are maintenance free, no maintenance other than cleaning is necessary. The level of cleaning can vary depending on local conditions. Undertake cleaning at least twice a year. Inlet and exhaust grilles, impeller and elements can be vacuum cleaned or wiped using a damp cloth. Use a brush when vacuuming to prevent damaging sensitive parts. Avoid the use of strong alkaline or acidic cleaning agents.

Overheating

The air curtain unit with electric heater is equipped with an overheat protector. If it is deployed due to overheating, reset as follows:

1. Disconnect the electricity with the fully isolated switch.
2. Allow the electrical coil to cool.
3. Determine the cause of overheating and rectify the fault.

Reset is performed as follows:

1. Locate the red button inside the air curtain unit. It is visible and accessible by opening of the service hatch and inlet grille. The button is on the left side seen from inside the room looking out. On the 2 metre variant, two red buttons are installed in the middle of the unit.
2. Press the red button until a click is heard.
3. Connect the air curtain again.

All motors are equipped with an integral thermal safety cut-out. This will operate, stopping the air curtain should the motor temperature rise too high. The cut-out will automatically reset when the motor temperature has returned to within the motor's operating limits.

Temperature control

Temperature control of SIRE maintains the exhaust temperature at +40 °C. If the temperature should exceed anyway there is an over heating alarm. For more information see the manual for SIRE.

Fan replacement

1. Determine which of the fans is not functioning.
2. Disconnect the cables to the relevant fan.
3. Remove the screws securing the fan and lift the fan out.
4. Install the new fan as above in reverse order.

Replacing the electric heater/coil (E)

1. Mark and disconnect the cables to the electric heater/coil.
2. Remove the mounting screws securing the electric heater/coil in the unit and lift the electric heater/coil out.
3. Install the new electric heater/coil in reverse order to the above.

Replacing the water coil (W)

1. Shut off the water supply to the unit.
2. Disconnect the connections to the water coil.
3. Remove the mounting screws securing the coil in the unit and lift the coil out.
4. Install the new coil in reverse order to the above.

Draining the water coil (W)

The drain valve is on the underside of the coil on the connector side. It can be accessed via the service hatch.

Trouble shooting

If the fans are not working or do not blow properly, check the following:

- That the intake grille/filter is not dirty.
- Check the functions and settings of the control system SIRE, see manual for SIRE.

If there is no heat, check the following:

- Check the functions and settings of the control system SIRE, see manual for SIRE.

For units with electrical heating, check also the following:

- Power supply to electric heater coil; check fuses and circuit-breaker (if any).
- That the overheat protection for the motors has not been deployed.

For units with water coil, check also the following:

- That the water coil is air free.

- That there is enough water flow.
- That incoming water is heated enough.

If the fault cannot be rectified, please contact a qualified service technician.

Residual current circuit breaker (E)

When the installation is protected by means of a residual current circuit breaker, which trips when the appliance is connected, this may be due to moisture in the heating element. When an appliance containing a heater element has not been used for a long period or stored in a damp environment, moisture can enter the element.

This should not be seen as a fault, but is simply rectified by connecting the appliance to the mains supply via a socket without a safety cut-out, so that the moisture can be eliminated from the element. The drying time can vary from a few hours to a few days. As a preventive measure, the unit should occasionally be run for a short time when it is not being used for extended periods of time.

Safety

- *For all installations of electrically heated products should a residual current circuit breaker 300 mA for fire protection be used.*
- *Keep the areas around the air intake and exhaust grilles free from possible obstructions!*
- *During operation the surfaces of the unit can be hot!*
- *The unit must not be fully or partially covered with clothing, or similar materials, as overheating can result in a fire risk! (AR3500E)*
- *This appliance can be used by children aged from 8 years and above and persons with reduced physical, sensory or mental capabilities or lack of experience and knowledge if they have been given supervision or instruction concerning use of the appliance in a safe way and understand the hazards involved. Children shall not play with the appliance. Cleaning and user maintenance shall not be made by children without supervision.*



Main office

Frico AB
Box 102
SE-433 22 Partille
Sweden

Tel: +46 31 336 86 00

mailbox@frico.se
www.frico.se

**For latest updated information and information
about your local contact: www.frico.se**