

Installation Instruction

Istruzioni di montaggio

Installationsanleitung

Instructions d'installation

Instrucciones de montaje

DOMOLED

Round/Square

Track Lighting

Apparecchio da binario

Track Lighting

Projecteurs sur rail 230V

Luminarias para Binario

Art.

6345

6346

6347

6348

6349

6350

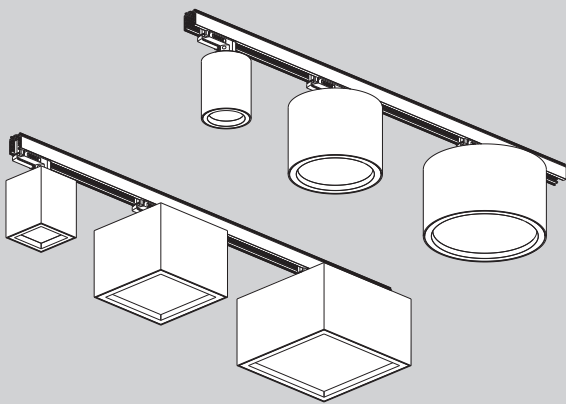

CAUTIONS

AVVERTENZE, WARNUNG PRECAUTIONS, PRECAUCIONES

1. Switch-off the power supply before any installation and maintenance operations.

Use only a two-pole switch

Staccare la linea elettrica prima dell'installazione e di ogni intervento di manutenzione.

Utilizzare un interruttore bipolare

Die Stromzufuhr muss vor der Installation /
Wartung ausgeschaltet werden.

Nur mit einem zweipoligen Stecker
zu verwenden

Couper la source d'alimentation avant toute
installation et opération d'entretien.

Seulement utiliser avec un
connecteur bipolaires

No efectuar la conexión de la
lámpara con la tensión general
activada.

Usar un interruptor bipolar

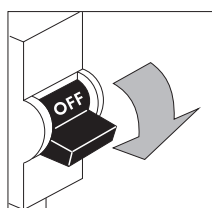

2. Installation should be carried out by a suitably qualified person in accordance with good electrical practice and the appropriate national wiring regulations.

L'installazione deve essere effettuata da personale qualificato secondo la normativa elettrica vigente.

Die Installation muss nach den gültigen Sicherheitsvorschriften durch einen konzessionierten Elektroinstallateur erfolgen.

L'installation doit être réalisée par un électricien qualifié en respectant les prescriptions en vigueur.

La instalación debe ser realizada por una persona cualificada y de acuerdo a la normativa vigente.

3. Use this light fixture at the rated voltage and frequency as indicated on the specification table.

Utilizzare questo apparecchio a tensione e frequenza indicate nella tabella.

Die Leuchte darf nur mit der angegebenen Spannung und Frequenz betrieben werden.

Respecter les prescriptions de tension et de fréquence indiquées dans le tableau final.

Utilice esta lámpara a la tensión y frecuencia indicadas en las instrucciones.

4. This instruction sheet must be referred to any retained by the person responsible for the installation & servicing.

Queste istruzioni di montaggio devono essere conservate dal responsabile dell'installazione e manutenzione dell'apparecchio.

Bewahren Sie diese Gebrauchsanweisung für den verantwortlichen Benutzer /
Wartungstechniker auf.

Gardez cette instruction pour l'utilisateur /
technicien de maintenance.

Estas instrucciones debes ser conservadas por el responsable del mantenimiento de la instalación.

INSTALLATION

INSTALLAZIONE, MONTAGE INSTALLATION, INSTALACIÓN

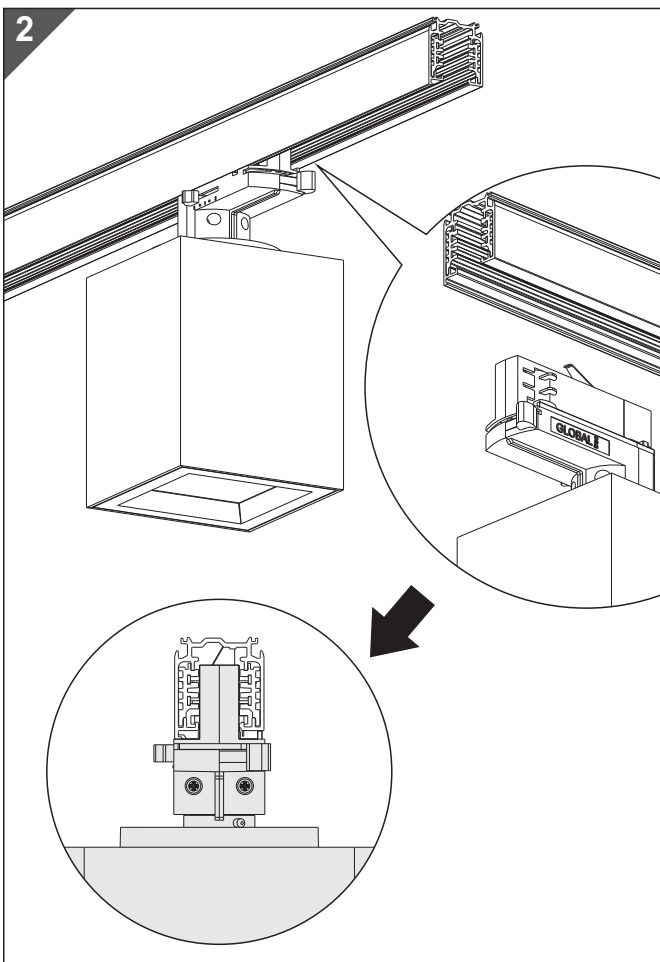
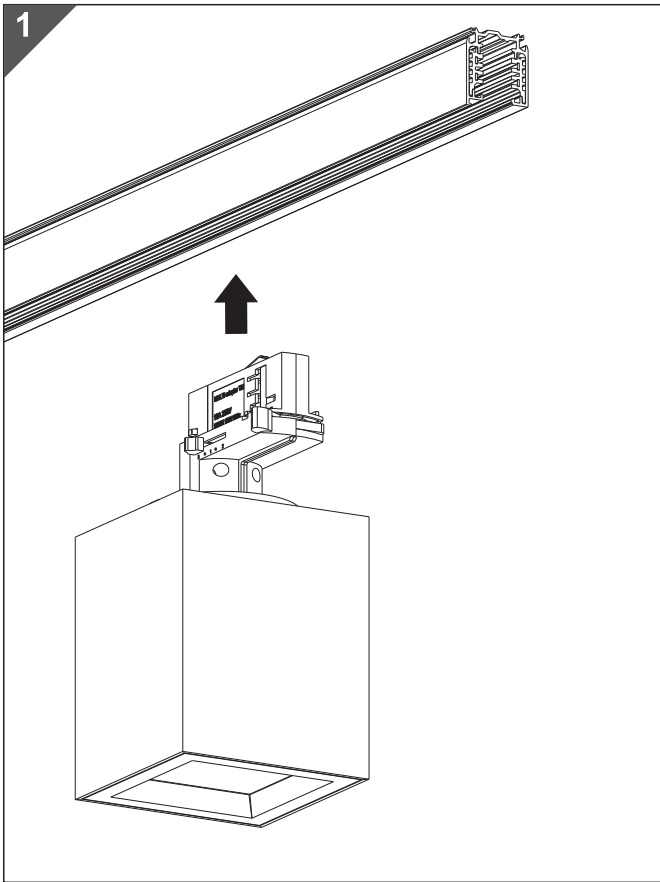

MEASUREMENT

DIMENSIONI, ABMESSUNGEN DIMENSIONS, MEDIDAS

in mm

6345

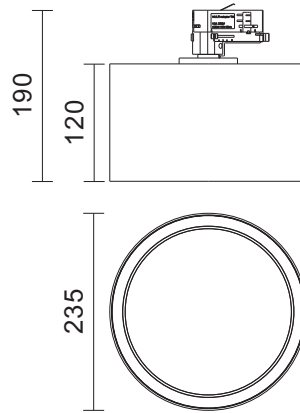

6348

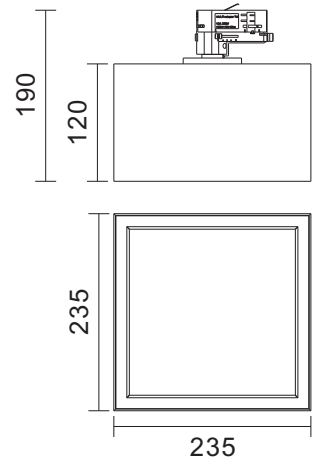

6346

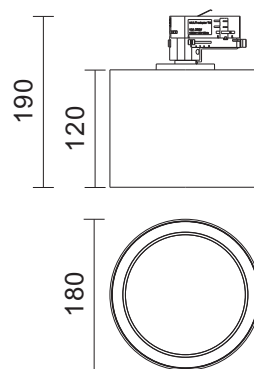

6349

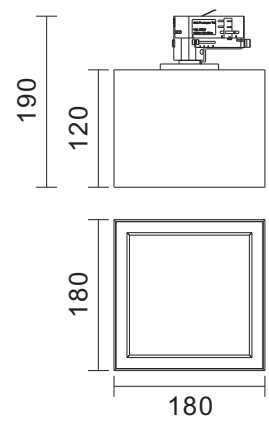

6347

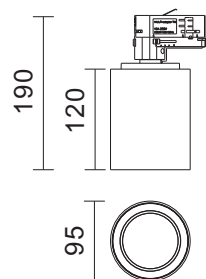



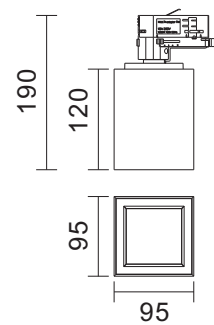



6350



SPECIFICATION

CARATTERISTICHE, BESCHREIBUNG CARACTERISTIQUES, ESPECIFICACIONES

Art.	Max. Wattage(W)	Volt.(V) /f(Hz)	Lamp	Remarks	Class
6345	35	220-240 50/60	LED	*	
6346	25	220-240 50/60	LED	*	
6347	12	220-240 50/60	LED	*	
6348	35	220-240 50/60	LED	*	
6349	25	220-240 50/60	LED	*	
6350	12	220-240 50/60	LED	*	

* LED and remote LED driver included.
LED e alimentatore LED remoto compresi.
Inklusive LED und remote LED Driver.
LED et driver LED déporté inclus.
LED y remoto alimentador incluidos.

IP20 CE 

formalighting

Forma Lighting (Italia) S.r.l.

Tel : (+39) 02 9354 0300
Fax : (+39) 02 9343 5117

Email : formaitalia@formalighting.it
Address : Via Europa, 35/A
20010 Pogliano Mil.se MI

Forma Lighting (HK) Ltd.

Tel : (+852) 2516 6500
Fax : (+852) 2516 6525

Email : forma@forma.com.hk
Address : Room 4, 5/F.,
Eastern Harbour Centre
28 Hoi Chak Street
Quarry Bay, Hong Kong.