

Installation Instruction

Istruzioni di montaggio

Installationsanleitung

Instructions d'installation

Instrucciones de montaje

DADO

Track Lighting
Apparecchio da binario
Track Lighting
Projecteurs sur rail 230V
Luminarias para Binario

Art.

6090
6091
6113
6126

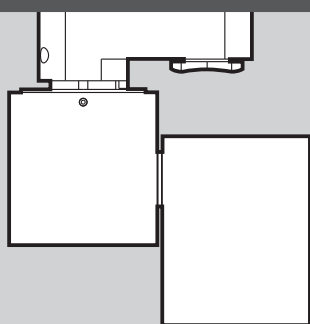

CAUTIONS

AVVERTENZE, WARNUNG PRECAUTIONS, PRECAUCIONES

1. Switch-off the power supply before any installation and maintenance operations.

Use only a two-pole switch

Staccare la linea elettrica prima dell'installazione e di ogni intervento di manutenzione.

Utilizzare un interruttore bipolare

Die Stromzufuhr muss vor der Installation /
Wartung ausgeschaltet werden.

Nur mit einem zweipoligen Stecker
zu verwenden

Couper la source d'alimentation avant toute
installation et opération d'entretien.

Seulement utiliser avec un
connecteur bipolaires

No efectuar la conexión de la
lámpara con la tensión general
activada.

Usar un interruptor bipolar

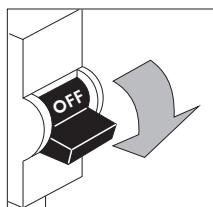

2. Installation should be carried out by a suitably qualified person in accordance with good electrical practice and the appropriate national wiring regulations.

L'installazione deve essere effettuata da personale qualificato secondo la normativa elettrica vigente.

Die Installation muss nach den gültigen Sicherheitsvorschriften durch einen konzessionierten Elektroinstallateur erfolgen.

L'installation doit être réalisée par un électricien qualifié en respectant les prescriptions en vigueur.

La instalación debe ser realizada por una persona cualificada y de acuerdo a la normativa vigente.

3. Use this light fixture at the rated voltage and frequency as indicated on the specification table.

Utilizzare questo apparecchio a tensione e frequenza indicate nella tabella.

Die Leuchte darf nur mit der angegebenen Spannung und Frequenz betrieben werden.

Respecter les prescriptions de tension et de fréquence indiquées dans le tableau final.

Utilice esta lámpara a la tensión y frecuencia indicadas en las instrucciones.

4. This instruction sheet must be referred to any retained by the person responsible for the installation & servicing.

Queste istruzioni di montaggio devono essere conservate dal responsabile dell'installazione e manutenzione dell'apparecchio.

Bewahren Sie diese Gebrauchsanweisung für den verantwortlichen Benutzer /
Wartungstechniker auf.

Gardez cette instruction pour l'utilisateur /
technicien de maintenance.

Estas instrucciones debes ser conservadas por el responsable del mantenimiento de la instalación.

INSTALLATION

INSTALLAZIONE, MONTAGE INSTALLATION, INSTALACIÓN

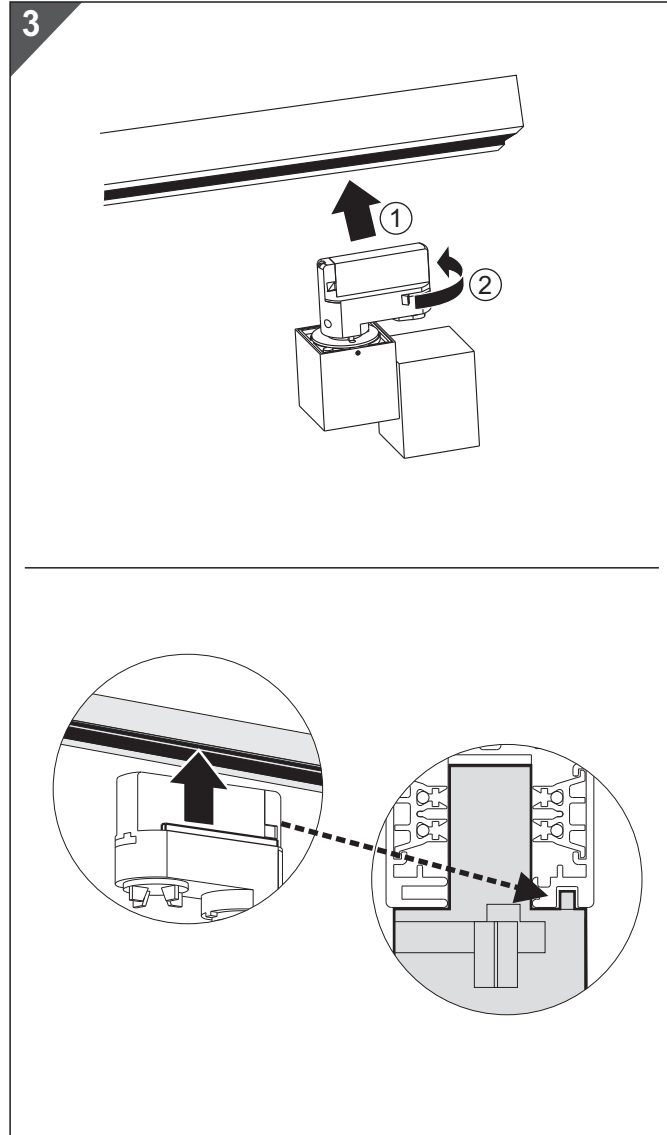
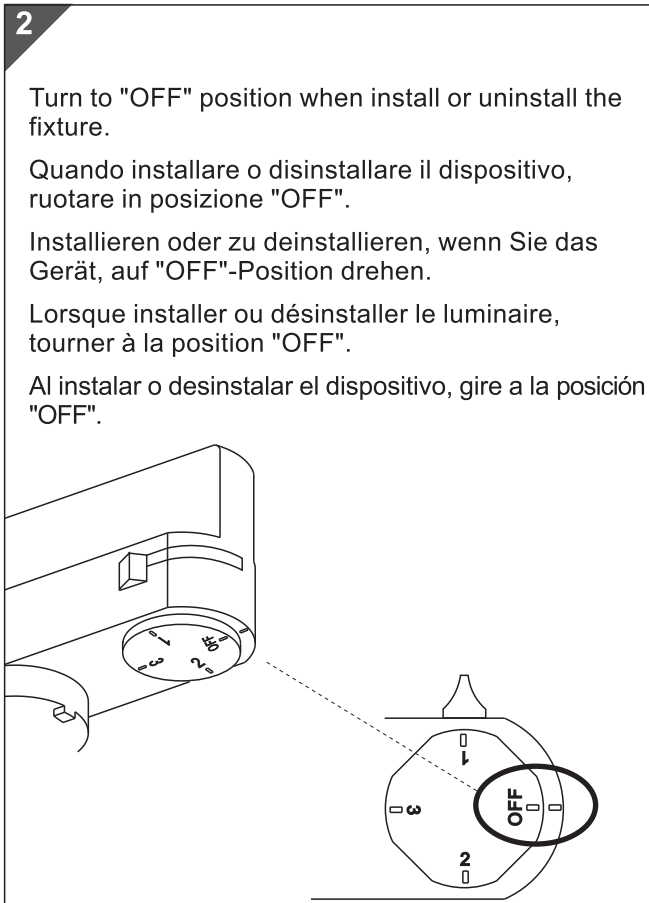
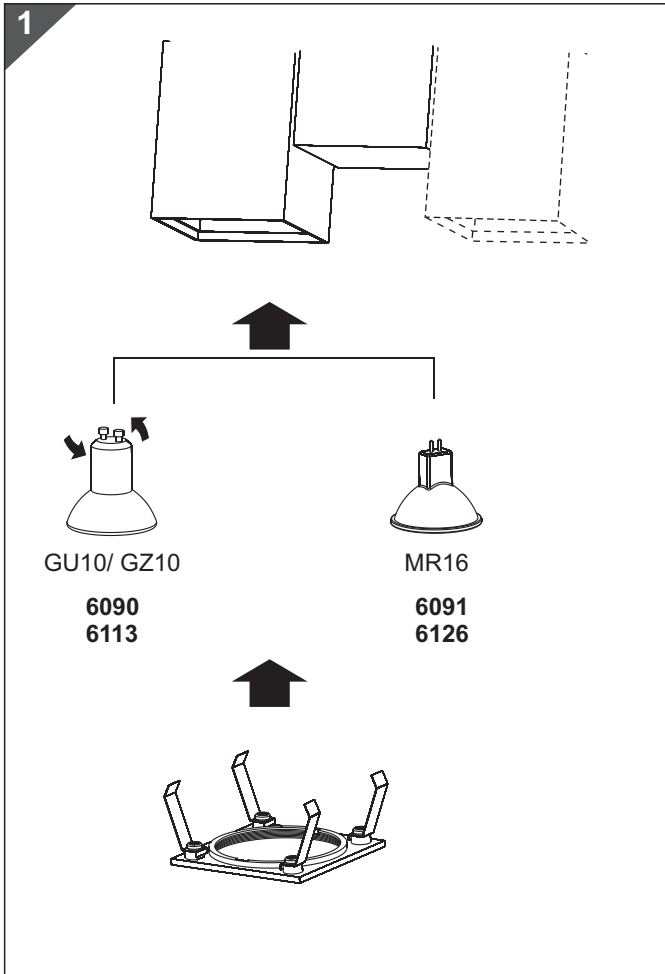

ANGLE ADJUSTMENT

ORIENTAMENTO DEL VANO OTTICO ORIENTERUNG DER OPTISCHEN ORIENTATION DU GROUPE OPTIQUE ORIENTABILIDAD DE LA OPTICA

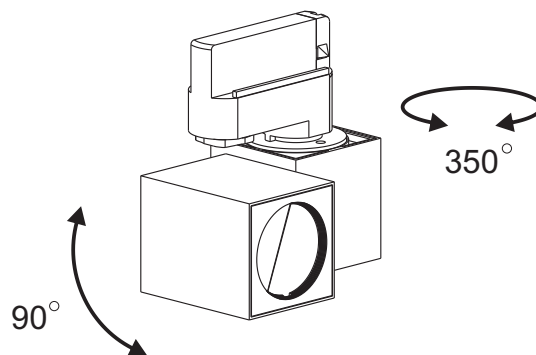

MEASUREMENT

DIMENSIONI, ABMESSUNGEN DIMENSIONS, MEDIDAS

in mm

Art.

6090
6091

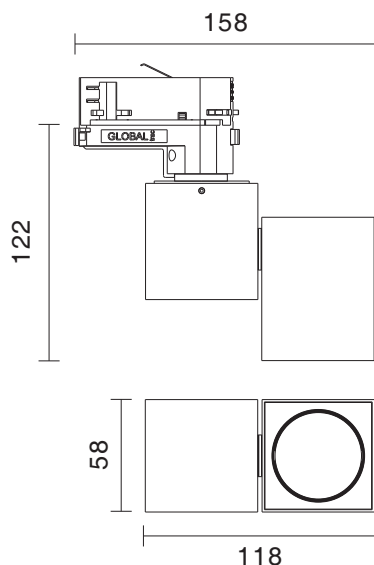

Art.

6113

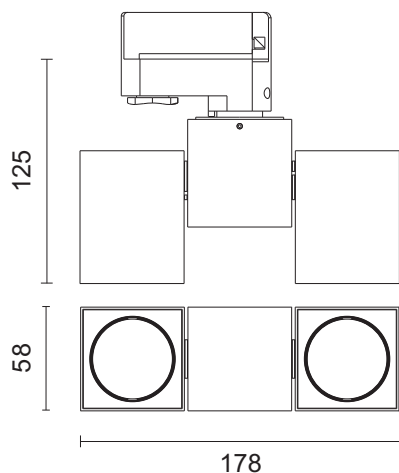





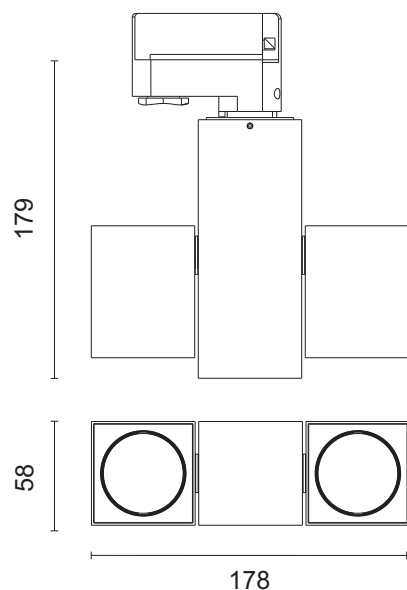











Art.

6126



SPECIFICATION

CARATTERISTICHE, BESCHREIBUNG CARACTERISTIQUES, ESPECIFICACIONES

ART.	Wattage (W)	Volt. (V) /f(Hz)	Lamp	Remarks	Class
6090	35	220-240 50/60	GU10/GZ10 Hal. 	N/A	
	6	220-240 50/60	GU10/GZ10 LED 	N/A	
6091	35	220-240 50/60	12V GU5.3 MR16 Hal. 	N/A	
	Max. 15	220-240 50/60	12V GU5.3 MR16 LED 	N/A	
6113	2 x 35	220-240 50/60	GU10/GZ10 Hal. 	N/A	
	2 x 6	220-240 50/60	GU10/GZ10 LED 	N/A	
6126	2 x 35	220-240 50/60	12V GU5.3 MR16 Hal. 	N/A	
	2 x Max.15	220-240 50/60	12V GU5.3 MR16 LED 	N/A	

Lamp not included.
Lampada non compresa.
Exklusive Leuchtmittel.
Sources lumineuses exclues.
Lámpara no incluida.

IP20  

formalighting

Forma Lighting (Italia) S.r.l.

Tel : (+39) 02 9354 0300
Fax : (+39) 02 9343 5117

Email : formaitalia@formalighting.it
Address : Via Europa, 35/A
20010 Pogliano Mil.se MI

Forma Lighting (HK) Ltd.

Tel : (+852) 2516 6500
Fax : (+852) 2516 6525

Email : forma@forma.com.hk
Address : Room 4, 5/F.,
Eastern Harbour Centre
28 Hoi Chak Street
Quarry Bay, Hong Kong.