

**Underground Drainage Systems**



## High Quality Underground Drainage System

are an established market leader in the manufacture and supply of Plastic Building and Plumbing systems in the UK. The Company's specialist areas are PVC-UE Roofline, Window & Cladding Systems, Rainwater Systems, Soil & Waste Systems, Hot & Cold Plumbing Systems, and Underground Drainage Systems.

**FloPlast** Underground Drainage Systems comply where applicable with the requirements of the following British Standards.

**BS EN 1401-1:** 2009 PVC-U  
Underground Drainage Systems

**BS4660:** 2000 PVC-U  
Ancillary Items ( Rodding Eyes, Access fittings etc)

**BS EN 124:** 1994 Access Covers, Gratings and Frames.

**BS 7158:** 2001 Plastic Inspection Chamber for Drainage.

 Drainage Pipe has a British Standard Kitemark.

### Standards/Quality Control



FloPlast operates quality and environment management systems which have been accredited by BSI to both BS EN ISO 9001:2008 Certificate No. FM 501414 and BS EN ISO 14001:2004 Certificate No. EMS 538445.

All products are subject to continuous quality control procedures and products manufactured to British Standard Specifications are marked accordingly.



### **Transport, Handling & Storage**

**FloPlast** PVC-U pipes are supplied in secure bales bound with straps within timber frames, **FloPlast** recommend that movement of bales is carried out by fork lift or other mechanical device using webbing or rope strings.

The bales may be stacked up to a maximum of three high, providing that the timber frames are placed on each other.

Fittings are generally supplied in plastic bags and should be stored away from direct sunlight. If they have to be stored outside, the bags should be opened to prevent temperature build-up.

### **Application**

**FloPlast** Underground Drainage Systems are designed for use in gravity drainage and sewerage installations at depths of up to ten metres.

### **Composition**

All drainage pipes and the majority of fittings are manufactured from unplasticised Polyvinyl Chloride (PVC-U). Inspection chambers, 0-90° adjustable bend, gully traps and gully grids are manufactured from polypropylene.

### **Colour**

Pipes and fittings are manufactured in Golden Brown with exceptions as indicated in the product guide.

### **Terms & Conditions of Sale**

Goods are sold subject to our Standard Terms and Conditions of Sale, copies of which are available upon request.

**FloPlast Limited** reserve the right to modify or extend any product range or published information without prior notice.



## 110mm Pipe & Fittings BS 4660:2000, BS EN 1401-1:2009, BS EN 124:1994, BS 7158:2001

- **FloPlast** Socketed Underground Pipe incorporates the latest blown end technology. The easy fit rubber seal is held in place via a circular plastic insert allowing a retention of the seal in transit and a perfect connection for jointing.
- All Push-Fit underground fittings have a captive seal and snap cap which are designed to be user-friendly - no sharp edges, and with space restrictions in mind, allow for an easy fit connection. The seal is double ribbed, and the sockets incorporate a recessed area to provide space for the rubber seal to locate as the pipe is inserted, forming a high-capacity pressure point.



<small>BS EN 1401:2009 / BS 4660:2000 BS 7158:2001 / BS EN 124:1994</small>	<b>110mm</b>	<b>160mm</b>
<b>Hepworth</b>	✓	✓
<b>Brett Martin</b>	✓	✓
<b>Osma/Wavin</b>	✓	✓
<b>Polypipe</b>	✓	✓
<b>Polypipe Terrain</b>	✓	✓
<b>Marley</b>	✓	✓
<b>Hunter</b>	✓	✓



### Pipe-Plain Ended

	SIZE	CODE
	3m	D043
	6m	D046



Bale Quantity - 50

### Pipe-Single Socket

	SIZE	CODE
	3m	D143
	6m	D146





Bale Quantity - 50

### Pipe Couplings







	CODE
 Single Socket	D124
 Double Socket*	D105

\*Removable centre stop for use as Slip Coupling

### Single Socket Bends

	CODE
 87½° Bend (Socket/Spigot)	D161
 45° Bend (Socket/Spigot)	D163
 30° Bend (Socket/Spigot)	D164
 15° Bend (Socket/Spigot)	D167



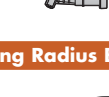

### Double Socket Bends

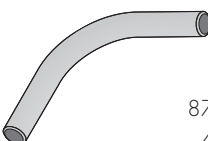
	CODE
 87½° Bend	D561
 45° Bend	D563
 30° Bend	D564
 15° Bend	D567
 87½° Rest Bend	D571
 87½° Settlement Rest Bend	D570
 0-90° Adjustable Bend (PP- Do not solvent weld)	D560



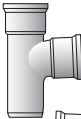

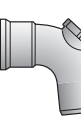

### Long Radius Bends

	CODE
 87½° Plain end	D281
45° Plain end	D283
87½° PE with Channel Access	D581
45° PE with Channel Access	D583

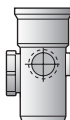
### Equal Junctions





	CODE
 87½° Junction (Double Socket)	D190
 45° Junction (Double Socket)	D210
 87½° Junction (Triple Socket)	D191
 45° Junction (Triple Socket)	D211

### Access Fittings

	CODE
 87½° Access Bend (Socket/Spigot)	D169
 Access Pipe (Socket/Spigot)	D274
 Screwed Access Cap	D292
 Channel Access Pipe PE 1.5m	D870
 PVC Oval Rodding Point (Spigot)	D881
 PVC Oval Rodding Point (Socketed)	D882
 PVC Sq. Rodding Point (Spigot)	D883
 PVC Sq. Rodding Point (Socketed)	D884

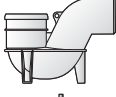
(45° rodding point with sealed access cover suitable for a loading up to 10 kN (1 tonne) where the frame of the cover is supported by a concrete plinth).

### Universal Gully Traps

	CODE
 Universal Gully Trap (Socket/Spigot 45°)	D500
 Low Back 'P' Trap (Socket/Spigot 90°)	D501
 Leaf/Debris Interceptor (Black)	D94
 Spare Square Grid (Polypropylene)	D502
 Square Hopper incl' Polypropylene grid	D504
 Rectangular Hopper incl' Polypropylene Grid	D506

### DrainGuard

	CODE
 DrainGuard (black) (Fits square & round downpipe)	DG1

## 110mm Pipe & Fittings BS 4660:2000, BS EN 1401-1:2009, BS EN 124:1994, BS 7158:2001







- Provides an efficient means of waste water drainage and foul discharge from above ground drainage systems.
- Manufactured in PVC-U to give a strong durable product, lightweight and easy to work with and suitable for high temperatures and waste discharge.
- Fittings have an aesthetic modern look, are compact in size yet remain within the British Standard specification.
- Push-Fit joint through an innovatively designed seal and snap cap system.
- Comprehensive range of fittings to suit most installations and which integrate with all FloPlast Above and Below Ground Drainage Systems.
- Colours available: Terracotta.











### Ancillaries

800gm Lubricant Gel	CODE
<a href="#">Water Council Approved KIWA KM 51564 BS6209</a>	SG800
100gm Silicone Grease	SG100
400ml Silicone Lubricant Spray	SL400
125ml Solvent Cement	SC125
250ml Solvent Cement 	SC250

**Bottle Gully Traps**

	Bottle Gully Circular Grid	CODE D510
	Bottle Gully Rectangular Grid	D520
	Back Inlet Bottle Gully Rectangular Grid	D530
	Back Inlet Bottle Gully Circular Grid	D540
	Round Hopper & Grid (215mm Diameter with height adjustment of 32mm)	D514
	Rectangular Hopper & Grid (295mm x 216mm overall size with height adjustment of 32mm)	D524
	200mm Riser	D505



**Adaptors**

	110x50mm Waste Adaptor (Grey/Black)	CODE SP95
	110x68mm Rainwater Adaptor (Grey/Black)	SP96
	Universal Waste Adaptor (32/40/50mm)	D95
	Universal Rainwater Adaptor (Sq/Rd)	D96
	80x110mm Adaptor	D97
	160x110mm Level Invert (Socket/Spigot)	D99
	Supersleve Clay Adaptor (Black)	D100
	Hepsleve Clay Adaptor (Black)	D101

**Drain Connector (Grey/Black)**

	CODE SP107
--	---------------

**Flexible Coupling and Adaptor**





	SIZE Flexi-coupling 98mm -115mm	CODE D102
	Flexi-adaptor A = 98mm - 115mm B = 120mm - 136mm	D103
	End Cap 105mm -116mm	SP113

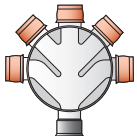
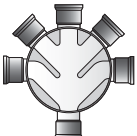

**Socket Plug**

	CODE D296
--	--------------

**Large Inspection Chamber - 450mm Diameter (LIC)**



	270mm deep Chamber Base - <b>5x110mm flexible inlets</b> Supplied with 4 socket plugs (Allows for 0-20° of movement)	CODE D900
	270mm deep Chamber Base - <b>5x110mm fixed inlets</b> Supplied with 4 socket plugs	D910
	235mm Extension Riser (can be cut to size)	D915
	Riser Sealing Ring (use with each Riser)	D935
	450mm screw down Plastic Cover & Frame (35 kN)	D930
	450mm Sealed screw down Plastic Cover & Frame with 350mm restricted access (for use with I.C. over 1.2mtr deep up to 3mtr) (35 kN)	D931



(To conform with new document H Building Regulations H2000 use D930 or D931 as required)

	Cast Iron Cover & Plastic Frame (35 kN)	D923
---	--	------

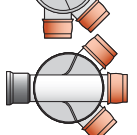
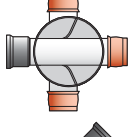
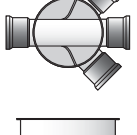
**Mini Access Chamber - 300mm Diameter (MAC)**

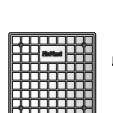
	270mm deep Multi inlet Chamber Base - <b>5x110mm flexible inlets</b> supplied with four socket plugs (allows 0-20° of movement)	CODE D800
	270mm 45° inlet Chamber Base - <b>3x110mm flexible inlets</b> supplied with two socket plugs (allows 0-20° of movement)	D801
	270mm 90° inlet Chamber Base - <b>3x110mm flexible inlets</b> supplied with two socket plugs (allows 0-20° of movement)	D802
	270mm 45° inlet Chamber Base - <b>3x110mm fixed inlets</b> supplied with two socket plugs	D810
	100mm Chamber Riser with integral rubber ring (60mm cut down facility)	D820
	200mm Chamber Riser with integral rubber ring (60/100/150mm cut down facility)	D822
	340mm Sealed Screw down cover and frame (35 kN)	D830

## Underground Drainage

### Installation Guide - Universal Gully Trap with access facility

- The gully should be assembled out of the ground.
- Place the gully on a substantial base e.g. Pre-cast concrete slab, bricks etc and stabilise by concreting base up to the level where the supporting feet meet the gully body. Ensure that concrete does not enter the ring seal joint.
- Connect the Access Bend (D169) onto the 45° spigot end of the gully using **FloPlast** Silicone Lubricant to assist with easy insertion.
- Make connection to drainage run using Socketed Pipe (D146).
- Backfill with suitable material to the required level.
- To complete the access installation, set in concrete an airtight 340mm Sealed PVC Cover and Frame (D830).

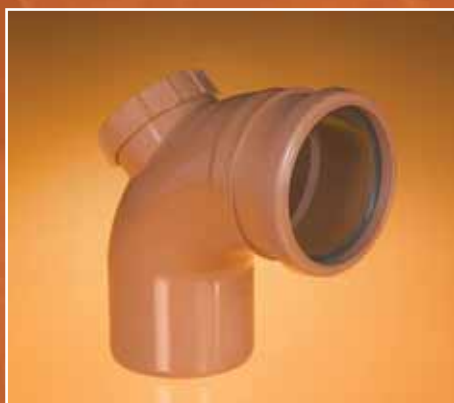
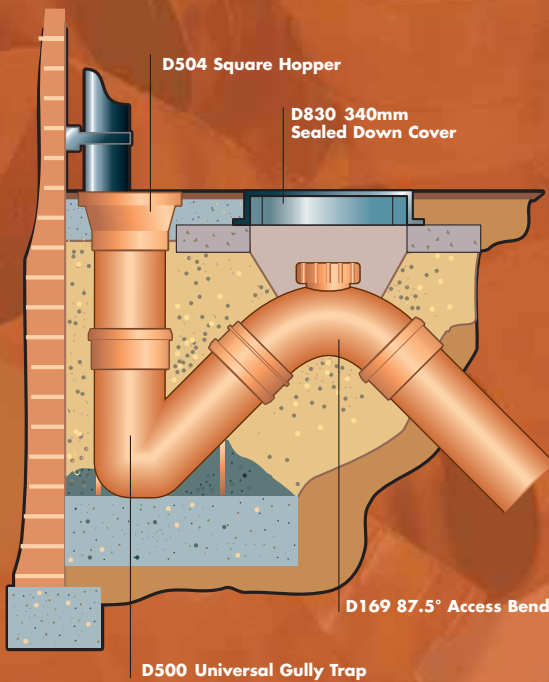

D169  
87.5°  
Access Bend



D560  
0-90° Adjustable Bend

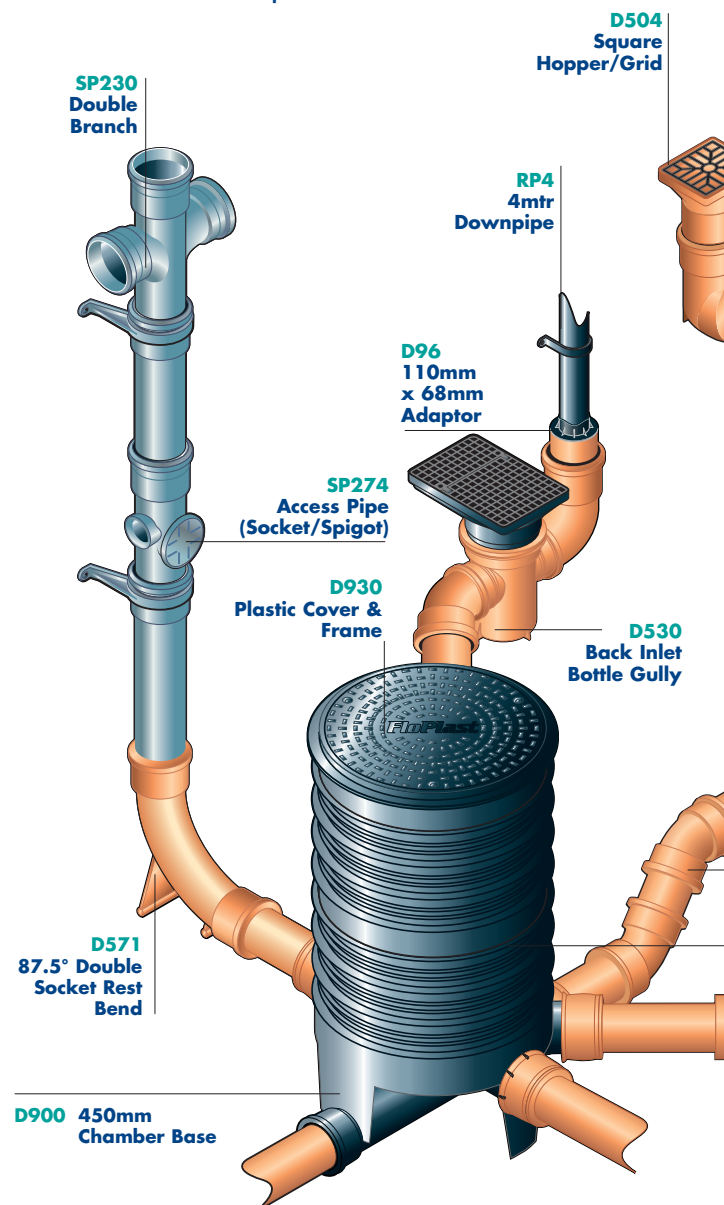

## Back Inlet Bottle Gully (BIG)

### Bottle Gully with rectangular hopper

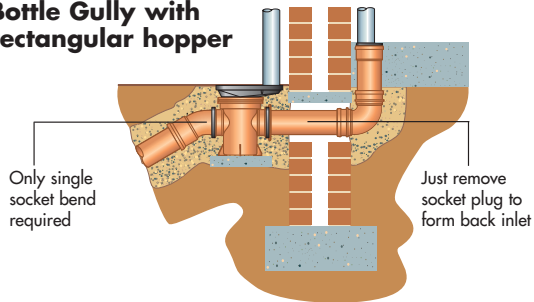

### Bottle Gully with circular hopper

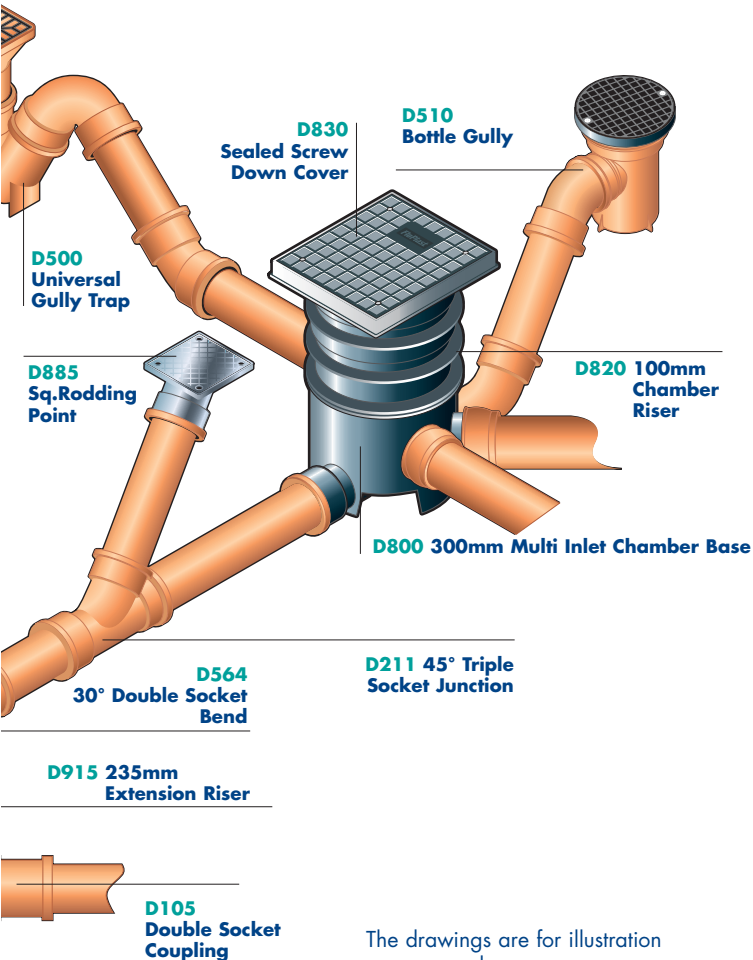
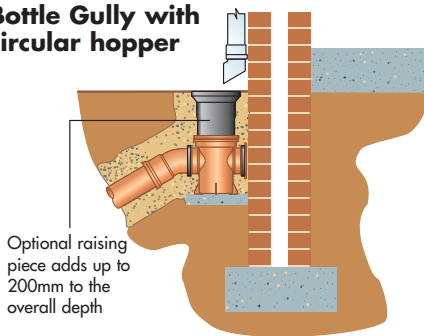

The drawings are for illustration purposes only. For detailed installation advice please contact your local stockist.

- Screw down, hinged rectangular heavy duty hopper.
- Heavy duty circular hopper available (D540).
- Both hoppers allow for height adjustment of 32mm.
- Sealed dip tube easily removed for rodding purposes.
- Gully riser allows an increase of invert depth up to 200mm (D505). Maximum of one riser only.
- Back inlet socket plug easily removed. No need to drill.



## Inspection Chambers (Polypropylene)

**FloPlast** 300mm Mini Access Chamber and 450mm Large Inspection Chamber offer an alternative to traditional manholes and may be used in depths of up to 600mm for the MAC, 1200mm and 3000mm for the Large Inspection Chamber.

### 300mm Mini Access Chamber (MAC)

**FloPlast** innovative design for the MAC, brings unrivalled flexibility to the underground drainage market.

The MAC has flexible connections for all inlets allowing a 10° movement in any direction.

This is of great assistance to the installer where the connecting pipes are not perfectly aligned with the MAC inlets. In many instances it will eliminate the need to install an extra bend and provide a saving on the cost of the installation.

In addition, the variety of inlet combinations available on the **FloPlast** Mini Access Chamber and the choice of two chamber risers, 100mm and 200mm, provide installers with a significant advance in the ease of which they can plan and install their drainage system. The MAC base is designed to facilitate the stacking of bases on top of one another to give a space saving storage solution for the merchant stockist.

In summary, the **FloPlast** Mini Access Chamber design and flexibility provides a practical, innovative and cost effective solution for the provision of access in a drainage system.

BS 7158: 2001 Plastic Inspection Chamber for drainage.

UK Patent No. GB2357127.

### 450mm Diameter Large Inspection Chamber (LIC)

**FloPlast** product innovation is again demonstrated with its 450mm Diameter Large Inspection Chamber.

To comply with the changes to Approved Document H of The Building Regulations 2000, significant research and development has gone into the design of this unique product. The Chamber base incorporates five 110mm flexible inlets, which allow 10° of movement in any direction.

The plastic cover and frame can take loadings of up to a maximum of 35kN. Should the connection of D930/D931 cover and frame be required directly to the base D900/D910, then riser D935 must be used and cut to suit, by cutting just above the bottom most large flange/rib.

(Please ensure Sealing Rings are used in conjunction with each riser section).

**FloPlast** installation details are concise, however they are provided as general guidelines only.

**FloPlast** recommend that reference should be made to the appropriate Codes of Practice for Underground Drainage Systems.

European Standards BS EN 752: 1997 Drain and sewer systems outside buildings and BS EN 1610: 1998 Construction and testing of drains and sewers, have been introduced. These have replaced British Standards BS8301 (Code of Practice for Building Drainage).

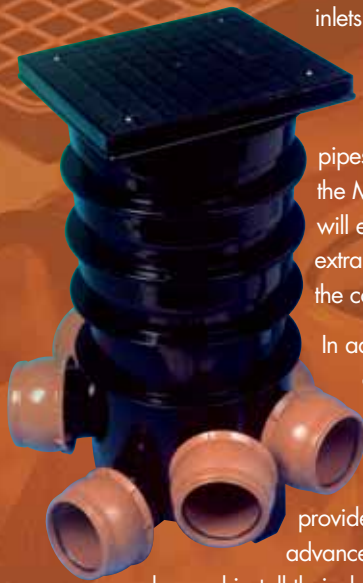

## Useful Measurements for Installation of MAC & LIC

	Mac	inc' Lid
<b>Base only</b>	270	300
<b>Base + one riser (100mm)</b>	370	400
<b>Base + one riser (200mm)</b>	470	500
<b>Base + (1 x 100 x 1 x 200) risers</b>	570	600

LIC Invert Depth (mm)	270	505	740	975	1210	1445	1680	1915	2150	2385	2620	2855	3090
<b>Number of Risers Required</b>	Base only	1	2	3	4	5	6	7	8	9	10	11	12
<b>Cover required</b>		(D930) 450mm opening up to a maximum of 1200mm						(D931) 350mm opening up to a maximum of 3000mm					

# 160mm Pipe & Fittings, PVC-U BS EN 1401-1:2009, BS EN 124:1994, BS 7158:2001

## Pipe-Plain Ended



SIZE CODE  
6m 6D046



Bale Quantity - 35

## Pipe-Single Socket



SIZE CODE  
3m 6D143  
6m 6D146



Bale Quantity - 35

## Pipe Coupling



Double Socket CODE  
6D105

## Single Socket Bends

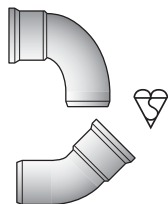

CODE  
87½° Bend (Socket/Spigot) 6D161  
45° Bend (Socket/Spigot) 6D163  
30° Bend (Socket/Spigot) 6D164  
15° Bend (Socket/Spigot) 6D167

## Double Socket Bends

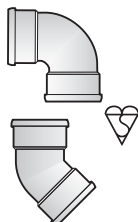

CODE  
87½° Bend 6D561  
45° Bend 6D563  
30° Bend 6D564  
15° Bend 6D567

## Adaptors



160x110mm Level Invert Socket/Spigot

CODE  
D99



Flexi-adaptor Cast Iron/160mm

6D102



Clay Adaptor A = 160mm - 180mm  
B = 180mm - 200mm

6D104

## Equal Junctions

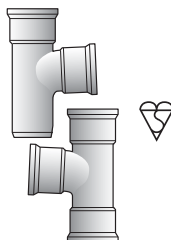

CODE  
87½° Junction (Double Socket) 6D190  
45° Junction (Double Socket) 6D210  
87½° Junction (Triple Socket) 6D191  
45° Junction (Triple Socket) 6D211

## 160/110 Unequal Junctions

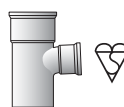

CODE  
160 x 110mm 6D198  
87½° Junction (Double Socket)  
160 x 110mm 6D218  
45° Junction (Double Socket)

## 160mm Large Inspection Chamber - 450mm Diameter (LIC)

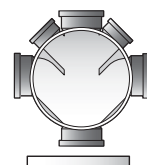

CODE  
160mm x 160mm 6D900  
90° Chamber Base -  
with two 45° 110mm Inlets



235mm Extension Riser  
(can be cut to size)



Riser Sealing Ring  
(use with each Riser)



450mm screw down  
Plastic Cover & Frame  
(35 kN)



450mm Sealed screw down  
Plastic Cover & Frame  
with 350mm restricted access  
(35 kN)



(for use with I.C. over 1.2mtr  
deep up to 3mtr)

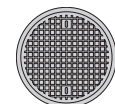

Cast Iron Cover & Plastic Frame  
(35 kN)



(To conform with new document H Building Regulations H2000 use D930 or D931 as required)

## Ancillaries

CODE  
800gm Lubricant Gel SG800  
Water Council Approved KIWA KM 51564 BS6209  
100gm Silicone Grease SG100  
400ml Silicone Lubricant Spray SL400  
125ml Solvent Cement SC125  
250ml Solvent Cement BS6209 SC250

## Installation Guide

### Trench Detail and Backfill Material

The trench should be constructed 300mm wider than the outside diameter of the pipe to be installed. Where the "as dug" material is suitable, the bottom of the trenches may be trimmed to form a pipe bed. The material can also be used as a sidefill and backfill.

Imported granular backfill materials such as pea shingle, used in accordance with the recommendations of BS5955 Part 6: 1980 Appendix A, having a nominal particle size not exceeding 10mm, should be used as required up to and over the crown of the pipe. When this has been achieved the "as dug" material can be replaced into the trench. Once 300mm of material has been replaced, mechanical compaction can commence.

### Testing

Testing of all drainage installations should be carried out in accordance with the requirements of the appropriate approving authority, using either air or water testing. References should be made to current editions of Building Regulations (Approved Document 'H') BS EN 752:1997 and BS EN 1610:1998. Where drainage appears inside buildings BS EN 12056 should also be consulted.

### Joining

#### Pipe End Preparation

When cutting pipes ensure that all ends are chamfered and are free from swarf, grit and dirt.

#### Ring Seal Joints

The **FloPlast** Ring Seal Joint acts as both a seal and expansion joint. The following sequence should be adhered to:

- Check that all ring seal sockets are properly located in their recessed position.
- Ensure spigots and ring seal sockets are dry, clean and free from grit and dirt.
- Lubricate all ring seal fittings. This will allow for a fast and efficient connection.
- Ensure all pipes and fittings are in the correct position.
- Insert pipe fully into the socket, then withdraw pipe by a minimum of 12mm. This will allow for expansion.

### Adaptors

External rainwater downpipes can be connected directly to a surface water drain or, depending on the design, via a gully trap to the underground drainage system.

The diameter of FloPlast's 110mm PVC-U above and below ground drainage systems are the same and therefore a direct connection may be achieved without the use of an adaptor. Where rainwater pipes connect directly to a drain, a suitable reducer will be required as follows:

- SP96 110mm x 68mm Rainwater Adaptor for round downpipe. RDS2 should be used with SP96 for connection to 65mm square downpipe.
- D96 Universal Rainwater Adaptor for square and round downpipe.
- D95 Universal Waste Adaptor for 32mm, 40mm and 50mm waste pipe connection to 110mm Soil/Drainage.

Connection to other materials such as Cast Iron, Supersleeve and Hepsleeve, is achieved by the use of a range of rigid and flexible couplings and adaptors.

### Access and Rodding Points

Access is very important on all installations for testing, inspection, and removal of any blockage or debris. Rodding in both directions can be achieved by using a Mini Access Chamber (MAC) or 450mm Large Inspection Chamber (LIC) in conjunction with access fittings.

Rodding points are more commonly used in storm water drainage systems where the rodding point is located at the head of the drain run connection to a chamber, and being no further than 22 metres away from the chamber. The rodding point should be enclosed in a concrete surround to provide support and to ensure that it does not become mislaid at ground level.

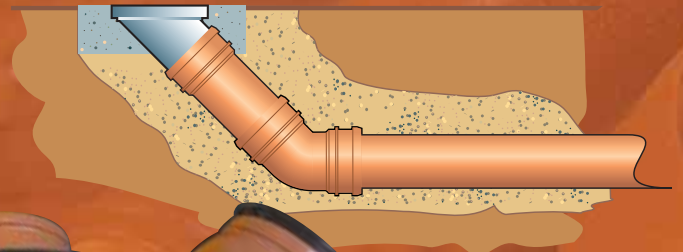

## Inspection Chambers

### Mini Access Chamber (MAC)

A mini access chamber has a relatively narrow riser shaft, and is used for inspecting, clearing, and rodding a drain line.

The narrowness of the riser shaft permits limited clearing and rodding to a maximum depth to invert of 600mm.

Any unused side connections should be sealed with a plain socket plug.

Should bends be required to change direction, these should be sited at the point of entry to the chamber.

Side branches of the chamber should not be used to change direction of the main flow, as a self-cleansing flow through the chamber cannot be guaranteed.

Intermediate depths can be achieved by cutting a riser at the indicated points.

The frame and cover should also be adjusted to suit the level of the adjacent ground and surrounded in a minimum of 50mm of concrete.



### Large Inspection Chamber (LIC)

#### incorporating Non Man Entry

#### Restricted Access

#### Cover & Frame

The large diameter of the riser shafts of inspection chambers enables them to be installed to a maximum depth to invert of 1200mm when used in conjunction with a 450mm opening cover and frame. The chamber complies with Approved Document H of the Building Regulations 2000 by using the 350mm reduced opening cover and frame for installations over 1200mm up to a maximum of 3000mm invert depth.

The chamber is installed on a suitable bed dependent on the quality of the trench and backfill materials.

Backfilling is continued up to approximately 50mm of the finished ground level.

The frame and cover are placed on a bed of concrete around the top of the uppermost shaft, and adjusted to the finished level.

The frame is securely fixed through the wall of the chamber at the set location points using self-tapping screws. The cover is then secured to the frame with the captive screws. It is impossible for the cover to be removed without undoing the screws.

Intermediate depths can be achieved by cutting the riser at 60mm intervals; the frame also has 55mm of telescopic adjustment.

Any unused side connections should be sealed with a plain socket plug.

Should bends be required to change direction, these should be sited at the point of entry to the chamber.

Side branches of the chamber should not be used to change the direction of the main flow, as a self-cleansing flow through the chamber cannot be guaranteed.

Should the connection of D930/D931 cover and frame be required directly to the base D900/D910, then riser D935 must be used and cut to suit, by cutting just above the bottom most large flange/rib.

When installing the 160mm Large Inspection Chamber, it is necessary to use the base adaptor ring, this allows the use of the 160mm Inspection Chamber Base, and the existing riser and lid products developed for the 110mm Inspection Chamber, please refer to the items for the **FloPlast** 160mm range on page 11.



## FloDrain Domestic Channel Drainage

- Quality domestic surface Channel Drainage 110mm x 100mm.
- Anti-slip heel guard grating.
- Garage Pack available (3 x 1m length, End Cap and Outlet).
- 5 tonne spread load. 1.5 tonne point load.
- 4 outlets per length for maximum flexibility.
- Quad section for corners and junctions.
- Concave grid for maximum flow.

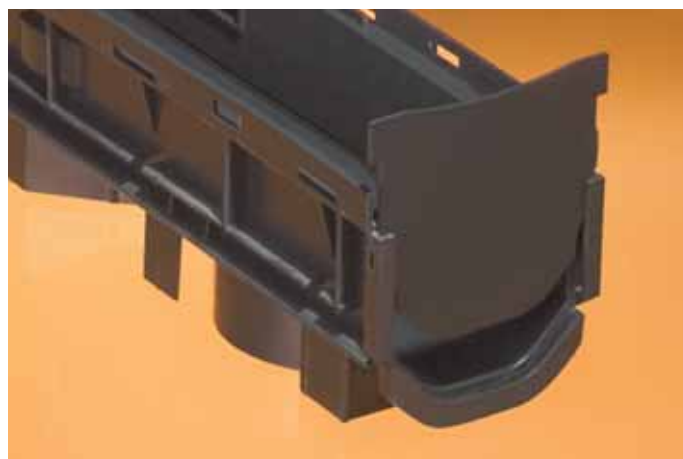
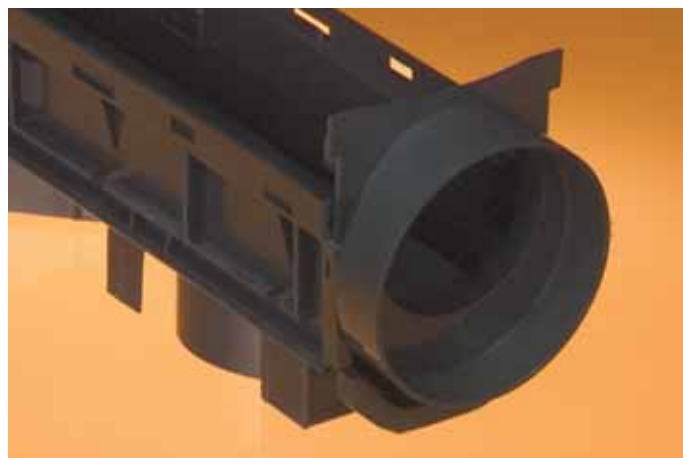
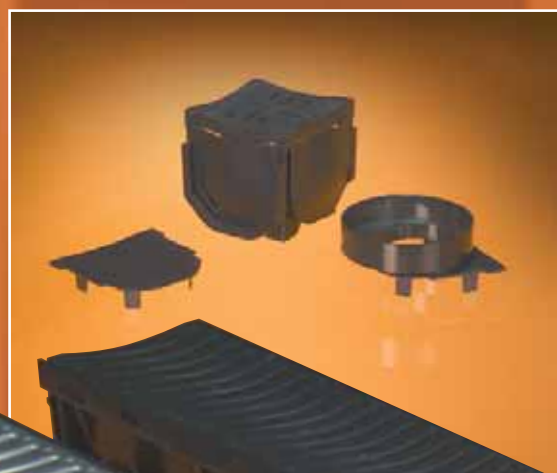

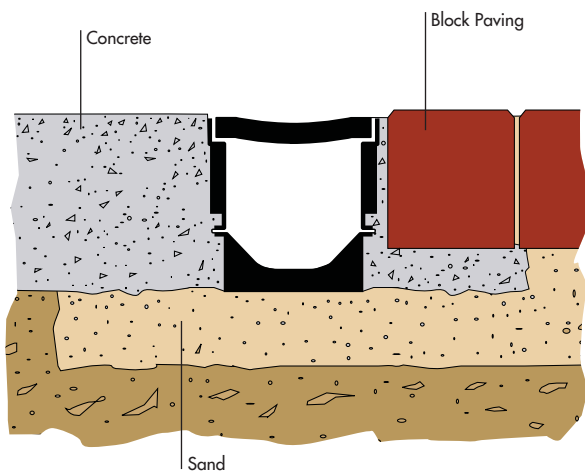

#### Channel-1 Metre Length (Including Grate)

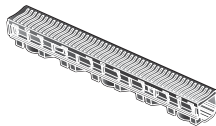

CODE  
D700

#### Drain Corner



CODE  
D710

#### Garage Pack

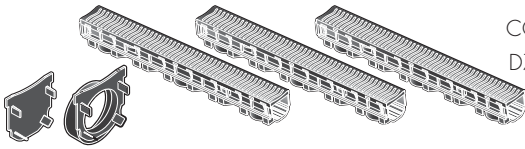

CODE  
D750

#### End Cap



CODE  
D711

#### End Outlet



CODE  
D712

#### Channel Drain with Galvanised Grate

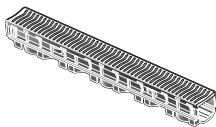

CODE  
D701

#### Drain Corner with Galvanised Grate



CODE  
D720

#### Galvanised Garage Pack

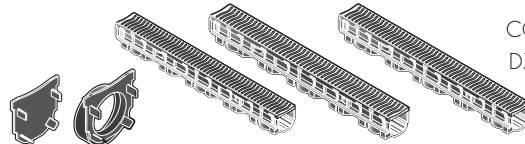

CODE  
D751

#### Galvanised Locking Bars (2 pack)



CODE  
D725

## Domestic Channel Drainage Easy To Install With Concrete or Paving

1. Dig trench for FloDrain, allowing for 50mm deep compacted sand base and wide enough for a minimum of 100mm backfill of concrete on each side.
2. Fix a string line to finishing height of grate 2mm below final surface level.
3. Allow a fall of approx. 5mm for every 1m length (1:200).
4. Start installation at lowest point of the run to accommodate any cut lengths which should be installed at the point furthest from the outlet.
5. FloDrain joints and end caps to be sealed with silicone sealant.
6. Use an End Cap at highest point of FloDrain.
7. Connect the lowest end of FloDrain to 110mm PVC-U BS EN1401 drainage pipe using either an end outlet or the preformed channel bottom outlet to allow water to drain away. Contact **FloPlast** for additional coupling details for other connections e.g. clay pipes etc.
8. FloDrain can be cut to length with a hacksaw. Install with grate fitted.
9. Protect grate with tape before concrete is poured.
10. Finish concrete 2mm above level of grate.
11. Allow 72 hours to cure before vehicle use or removing grates.
12. To remove grate, simply run a screwdriver along the edge of the grate to dislodge.
13. If installing block paving or paving slabs, haunch around channel with concrete to a height which allows the depth of the block or slab to finish 2mm above the level of grate.

All FloDrain Installations must be set in Concrete.

Should additional security be required when installing channel drainage with the galvanised grate, locking bars D725 (2 per 1 mtr length) are required.



# FloPlast

building the future

FloPlast Limited  
 Castle Road  
 Eurolink Business Park  
 Sittingbourne  
 Kent ME10 3FP  
 UK

Tel: 01795 431731

Sales Office Direct Line:  
**01795 421422**

Fax:  
**01795 431188**

E-mail:  
[sales@floplast.co.uk](mailto:sales@floplast.co.uk)

Website:  
[www.floplast.co.uk](http://www.floplast.co.uk)



KM 501316



KM 512474



KM 544331



KM 548614



[www.floplast.co.uk](http://www.floplast.co.uk)



## Other systems available



30/06/2010

PVC-UE Roofline,  
 Window &  
 Cladding Systems

Rainwater  
 Systems

Soil & Waste  
 Systems

Underground Drainage  
 Systems

MDPE  
 Systems

Hot & Cold  
 Plumbing Systems