



FLAMEPROOF ELECTRICAL ENCLOSURES LTD

Tat Bank Road, Oldbury, West Midlands B69 4NP

Telephone: 0121 541 1315 Fax: 0121 552 0592 E-mail: sales@feel.uk.net Website: www.feel.uk.net



Certificate No. 930015

RANGE DW

INDUSTRIAL / DEEP WATER IP68 (10 METRES) / ENCLOSURES

The enclosures are available in Stainless Steel grades 316 or 304, 2.5mm thick

Suitable for installation within areas prone to frequent or occasional flooding to depths up to 10 metres.

Entry into the enclosure is through customer specified plain clearance holes.

internal mounting brackets are provided as standard to enable the user to install their equipment. Internal chassis plates are available if required.

The covers of enclosures DW40 and above are fitted with concealed hinges permitting easy removal and replacement. All cover-fixing screws are 6mm captive and must be tightened to 3.5Nm to achieve the correct seal between body and cover.

Wall fixing is by way of slotted external lugs.

A re-formable neoprene gasket provides the seal between the cover and body of the enclosure.

FINISH: Natural

ALTERNATIVE FINISHES: Chemically Polished or Painted.

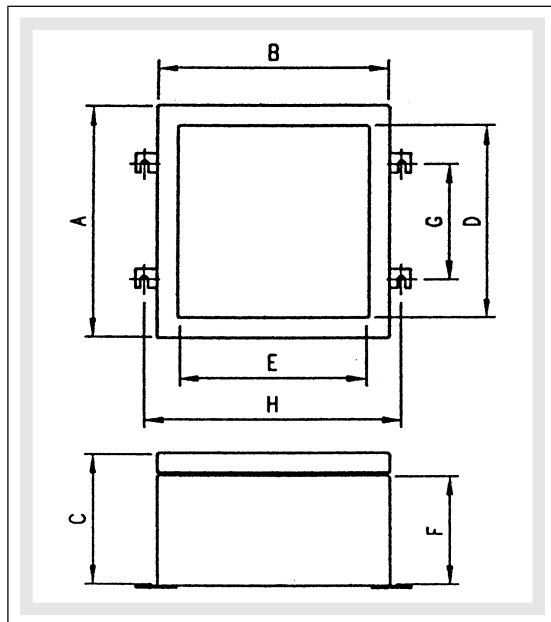
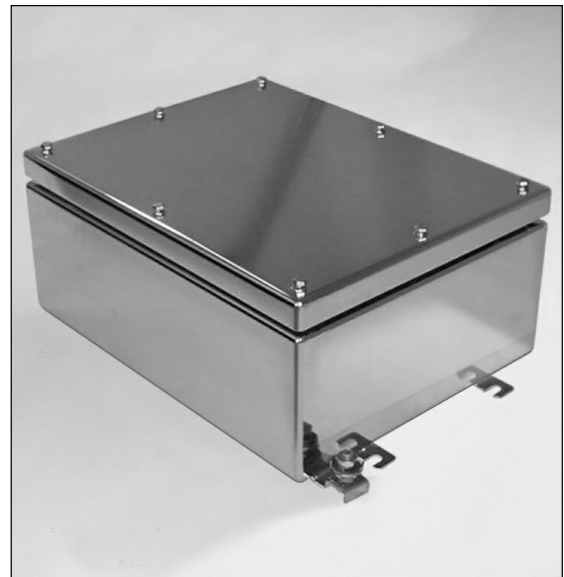

DIMENSIONS (Millimetres)

	A	B	C	D	E	F	G	H	Weight (Kgs)
DW09	116	116	73	100	100	65	138	Diagonal	1.6
DW20	193	123	83	180	110	75	130	130	3.0
DW35	280	140	118	267	127	110	180	150	5.0
DW40	220	300	169	170	250	140	110	335	12.0
DW40V	300	220	169	250	170	140	150	265	12.0
DW60	300	300	169	250	250	140	150	335	13.0
DW90	310	400	169	260	350	140	160	436	18.0
DW150	440	390	189	390	340	160	240	426	23.0
DW300	600	500	209	550	450	180	400	640	37.0

MOUNTING BOLT SIZE DW09, 20 & 35 = M6
 DW40, 40V, 60, & 150 = M8
 DW300 = M10

THE RIGHT CHOICE FOR QUALITY AND SERVICE