

 AIR COMFORT

AIR MOVEMENT

ROOF FANS

# ROOFMASTER STEF-ATEX ROOF FAN

» TECHNICAL CATALOGUE



# Contents

ROOFMASTER STEF-ATEX.....	3
Performance Data .....	4
Performance Table .....	4
General description.....	5
Fan Chart-explanation and definitions.....	
STEF-1 .....	7
STEF-2 .....	8
STEF-3 .....	9
STEF-4 .....	10
STEF-5 .....	11
STEF-6 .....	12
STEF-7 .....	13

## Accessories

Roof curb with insulation BOGA .....	14
Inlet sound attenuator STEZ-07.....	16
Safety switch SAFE .....	17
Frequency converter STYR.....	17

## Wiring

Star connection .....	18
-----------------------	----

## Important information

Information from Fläkt Woods - ATEX Directive 94/9/EC.....	19
--	----

# ROOFMASTER STEF-ATEX



## Features

7 sizes

- Volume flow up to 5 m<sup>3</sup>/s (18 000 m<sup>3</sup>/h)
- Max pressure rise up to 700 Pa
- Ex e-motor for DOL or Ex de-motor for frequency converter use
- Low sound level
- High efficiency
- ATEX Group IIB T3 Category 3G

## Electrical supply

- 3x400 V 50 Hz

## Ambient temperature range

- -20°C...+40°C

## Sizes

STEF-1, -2, -3, -4, -5, -6, -7

## Material and design

The fan casing is made of black pre-painted galvanized sheet or aluminium and zinc coated sheet steel. The surface treatment meets the requirements of environmental class C4 (EN ISO 1294-2). The fan is insulated inside against noise. The fan discharges air upwards.

## Impeller

Impeller is made of galvanized sheet steel (size 7 is made of welded steel and painted) and has backward curved blades. The impeller is dynamically balanced to Class Q6.3 in accordance with VDI 2060.

## Motor

Increased safety motors type Ex e IIB T3 are used when motor has connection direct on line. Flameproof motors type Ex de IIB T4 are for cases of frequency converter use. In this case the motor has an additional surface temperature sensor.

## Installation

The fan can be installed together with an installation frame FLOW, with different roof curbs or directly on a base.

## Speed control

Fan speed can be controlled by using a frequency converter and Ex de-motor. Frequency converter shall not be integrated inside of the roof fan. Special safety isolator shall be used.

## Product Code

### STEF-a-bbb-c-d-e

- a = size (1, 2, 3, 4, 5, 6, 7)
- bbb 0 = three phase motor
- bbb = number of poles
- c 1 = painted galvanized sheet metal, black  
2 = Al/Zn coated sheet steel
- d 9 = Ex e-motor (II T3, IP54, insulation class F)  
91 = Ex de-motor (IIB T4, IP55, insulation class F)
- e = generation

## Accessories



BOGA  
Roof curb



STEZ-07  
Inlet sound attenuator



SAFE  
Safety switch



STYR  
Frequency converter

# Performance Data and table

## ROOFMASTER STEF-ATEX – 3 phase

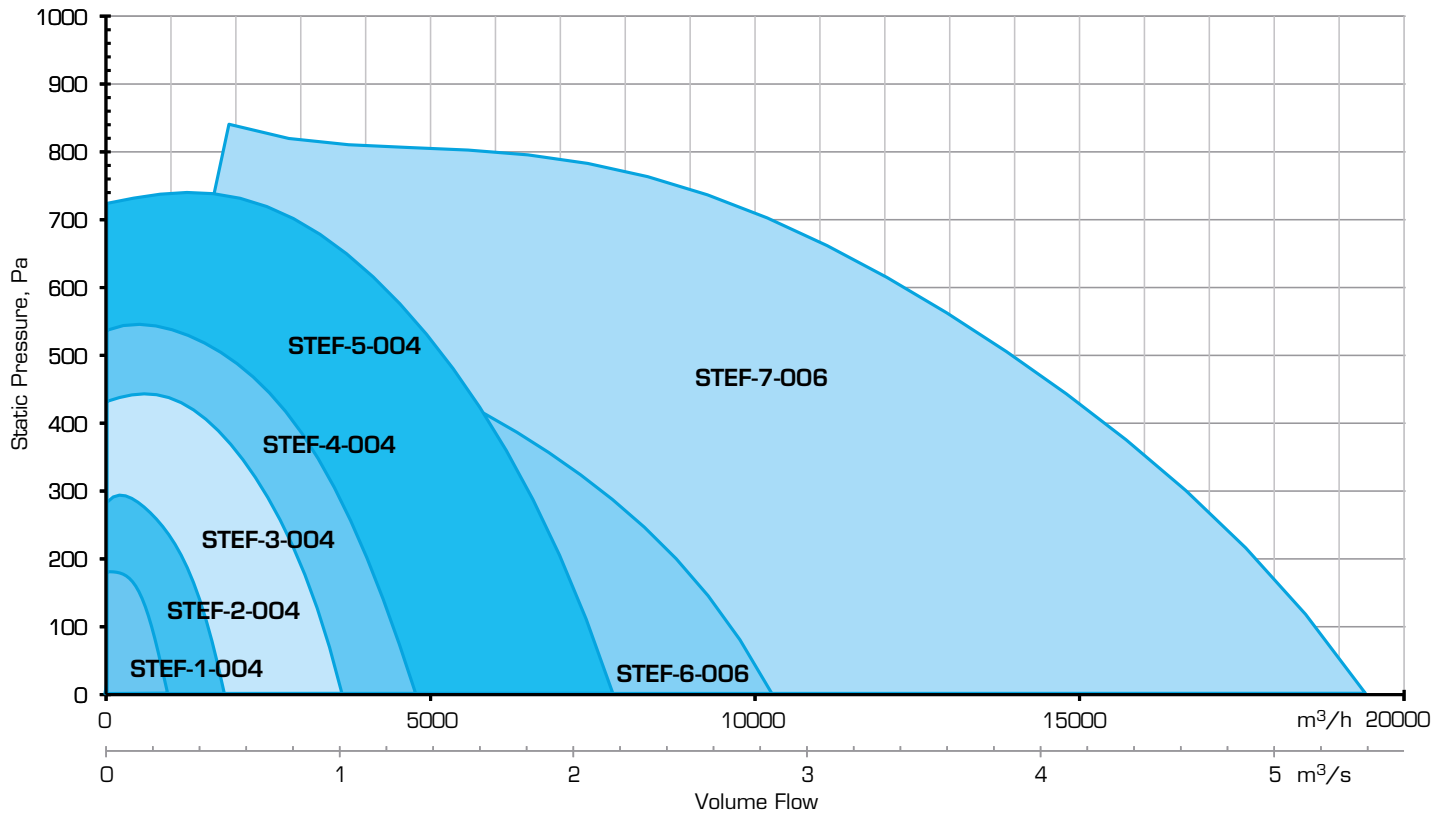

### Air flow m<sup>3</sup>/s as function of static pressure

	Pressure (Pa)														
	0	50	100	150	200	250	300	350	400	450	500	550	600	650	700
STEF-1-004	0,25	0,216	0,176	0,11											
STEF-2-004	0,465	0,431	0,387	0,331	0,247	0,064									
STEF-2-006	0,298	0,232	0,065												
STEF-3-004	0,968	0,928	0,882	0,828	0,765	0,689	0,596	0,475	0,257						
STEF-3-006	0,643	0,566	0,467	0,313											
STEF-4-004	1,26	1,209	1,155	1,098	1,034	0,964	0,882	0,784	0,658	0,474					
STEF-4-006	0,823	0,748	0,651	0,519	0,268										
STEF-5-004	2,072	2,019	1,962	1,9	1,832	1,758	1,678	1,589	1,49	1,38	1,255	1,109	0,928	0,652	
STEF-5-006	1,377	1,295	1,194	1,071	0,916	0,706									
STEF-6-006	2,671	2,58	2,474	2,35	2,201	2,023	1,811	1,559	1,231						
STEF-7-006	5,173	5,063	4,944	4,813	4,669	4,511	4,341	4,155	3,955	3,74	3,508	3,255	2,971	2,632	2,154

Airflow m<sup>3</sup>/s

### Air flow m<sup>3</sup>/h as function of static pressure

	Pressure (Pa)														
	0	50	100	150	200	250	300	350	400	450	500	550	600	650	700
STEF-1-004	900	778	634	396											
STEF-2-004	1674	1552	1393	1192	889	230									
STEF-2-006	1073	835	234												
STEF-3-004	3485	3341	3175	2981	2754	2480	2146	1710	925						
STEF-3-006	2315	2038	1681	1127											
STEF-4-004	4536	4352	4158	3953	3722	3470	3175	2822	2369	1706					
STEF-4-006	2963	2693	2344	1868	965										
STEF-5-004	7459	7268	7063	6840	6595	6329	6041	5720	5364	4968	4518	3992	3341	2347	
STEF-5-006	4957	4662	4298	3856	3298	2542									
STEF-6-006	9616	9288	8906	8460	7924	7283	6520	5612	4432						
STEF-7-006	18623	18227	17798	17327	16808	16240	15628	14958	14238	13464	12629	11718	10696	9475	7754

Airflow m<sup>3</sup>/h

# General description

## Application/specification

The equipment is a roof fan designed for use as an exhaust fan in ventilation systems conforming with ATEX Directive 94/9/EC. The fan is driven by:

**Increased safety motors type Ex e IIB T3 , fan classified to be used in explosive atmosphere as follows:**

Fan group:	Group II
Category:	Category 3
Zone:	2
Delivered medium:	Only gas excluding hydrogen
Gas explosion:	Generally IIB
Medium temperature:	Max +40° C
Temperature class:	T3

**Flameproof motors type Ex de IIB T4, fan classified to be used in explosive atmosphere as follows:**

Fan group:	Group II
Category:	Category 3
Zone:	2
Delivered medium:	Only gas excluding hydrogen
Gas explosion:	Generally IIB
Medium temperature:	Max +40° C
Temperature class:	T3

The fan is only intended for conveyance of air in zone 2 category 3 explosive atmospheres. The conveyance of solid matter is not permitted.

## Quiet operation

The inside of the fan casing and the side plates of the motor compartment have sound insulation. The fan itself has very low sound values. By using DCV (demand controlled ventilation) the operation point can be adjusted to optimize also sound levels.

## Material and design

The fan casing is made of black pre-painted galvanized sheet or aluminium and zinc coated sheet steel. STEF-ATEX can be used in industrial areas or close to the sea because the surface treatment meets the requirements of environmental class C4 (EN ISO 1294-2). The fan is insulated inside against noise. The fan discharges air vertically.

## Easy installation and service

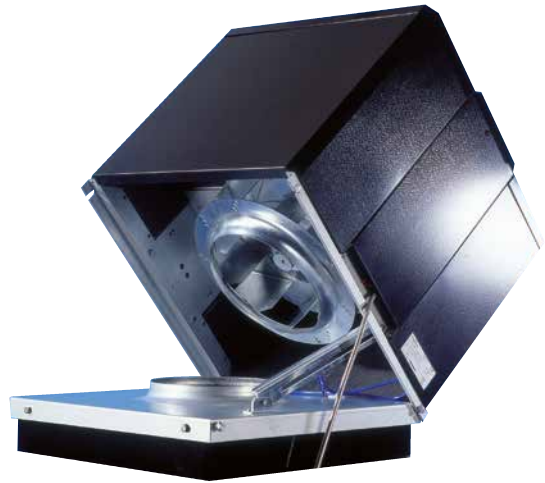

STEF-ATEX can be installed by using different roof curbs or directly on to the concrete. It is equipped with opening hinges as standard. The impeller and duct can be easily cleaned. The roof of the fan can be removed to perform maintenance of the motor.

## Motor and impeller

Increased safety motors type Ex e IIB T3 are used when the roof fan is connected directly to the mains.

Flameproof motors type Ex de IIB T4 are used together with a frequency converter. The motor is equipped with a surface temperature sensor.

The motor is outside of the air stream. Maximum exhaust temperature is + 40°C.

## Demand controlled ventilation

The demand for different air flows at different times of the day and during different seasons is increasing all the time. STEF-ATEX roof fans can be equipped with a frequency converter for speed control.

# Fan chart-explanation and definitions

## Symbols

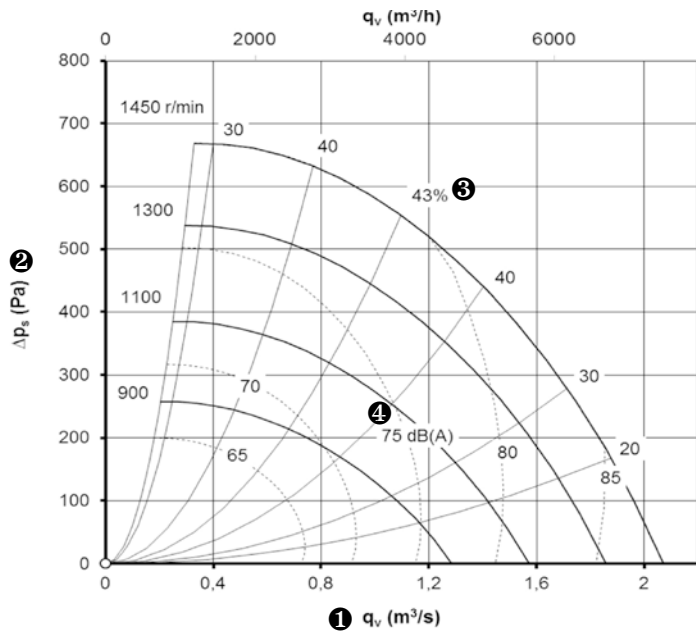

- ①  $Q_v$  Airflow  $m^3/s$
- ②  $\Delta p_s$  Static pressure rise Pa
- ③  $\eta$  Overall efficiency (impeller, motor and rotation speed control) at max rotation speed %
- ④  $L_{wA}$  A-weighted total sound level to surroundings dB(A)
- $L_{woct}$  Sound power level by octave bands (without A-weighting) dB
- $K_{oct}$  Correction when dividing into different octave bands dB
- $\Delta L$  Remote attenuation (given values calculated for an ideal case in a halfspace) dB

## Sound data

The total A-weighted sound power level to surroundings,  $L_{wA}$ , can be read in the fan chart. The correction coefficients by octave bands can be read in the chart below. The sound power level by octave band to the duct or to the surroundings (without A-weighting) can be obtained by using the following formula.

$$L_{woct} = L_{wA} + K_{oct}$$

## Sound pressure level and remote attenuation

Distance L (m)	1	3	5	10	15	20	25	30	40
Attenuation $\Delta L$ (dB)	7	17	22	28	31	34	36	37	40

The total sound pressure level to surroundings at different distances can be estimated using the following formula:

$$L_{pA} = L_{wA} - \Delta L$$

# STEF-1

STEF-1-004

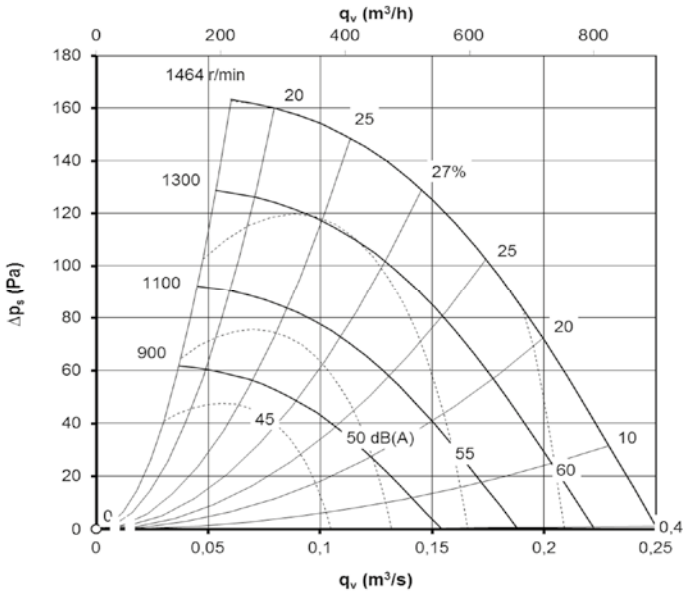

## Sound data

				Correction Kocf (dB)							
				Octave band mid-frequency (Hz)							
Fan code	Sound path	MinRPM	MaxRPM	63	125	250	500	1000	2000	4000	8000
STEF-1	Surroundings	0	1500	-2	9	3	-3	-10	-15	-19	-15
STEF-1	To the inlet duct	0	1500	-2	2	-3	-6	-3	-3	-13	-19

## Motor data

Motor nominal data at 50 Hz						
Fan code	Speed r/min	Output kW	Voltage V	Current (A)	STYR-1~230 V	STYR-3~400V
Flameproof enclosure design Ex de IIB T4, IP 5 insulation class F5						
1-004-c-91-5	1380	0,25	400 VY	0,77	STYR-13-1-S-d-1	STYR-14-3-S-d-1
Increased safety design E xe II T3, IP 54 insulation class F						
1-004-c-9-5	1380	0,25	400 VY	0,77	-	-

## Roof Fan

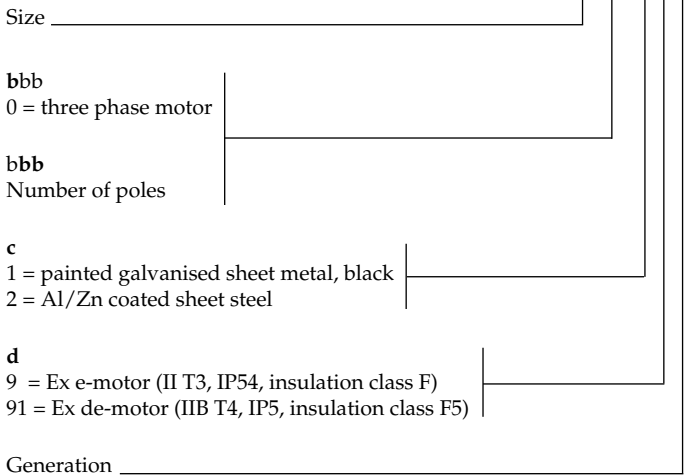

## Dimensional drawing

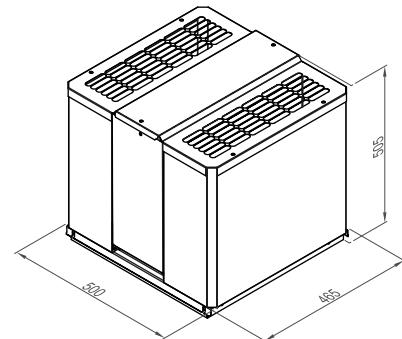

Weight 31 kg

Roof curb	BOGA-01-2-1-1
Inlet sound attenuator	STEZ-07-1
Safety switch	SAFE-4-0-0
Frequency converter (see motor table)	STYR-aa-b-S-0-1

# STEF-2

STEF-2-004

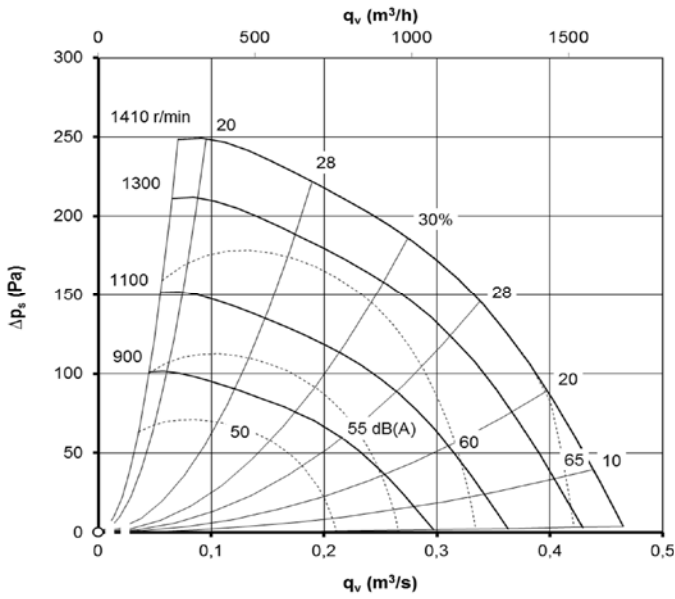

## Sound data

				Correction Kocf (dB)							
				Octave band mid-frequency (Hz)							
Fan code	Sound path	MinRPM	MaxRPM	63	125	250	500	1000	2000	4000	8000
STEF-2	Surroundings	0	1500	-3	8	3	-2	-8	-13	-17	-16
STEF-2	To the inlet duct	0	1500	1	1	-3	-6	-1	-5	-11	-19

## Motor data

Motor nominal data at 50 Hz							
Fan code	Speed r/min	Output kW	Voltage V	Current (A)	STYR-1~230 V	STYR-3~400V	
Flameproof enclosure design Ex de IIB T4, IP 5 insulation class F5							
2-004-c-91-5	1380	0,25	400 VY	0,77	STYR-13-1-S-d-1	STYR-14-3-S-d-1	
Increased safety design Ex e II T3, IP 54 insulation class F							
2-004-c-9-5	1380	0,25	400 VY	0,77	-	-	

## Roof Fan

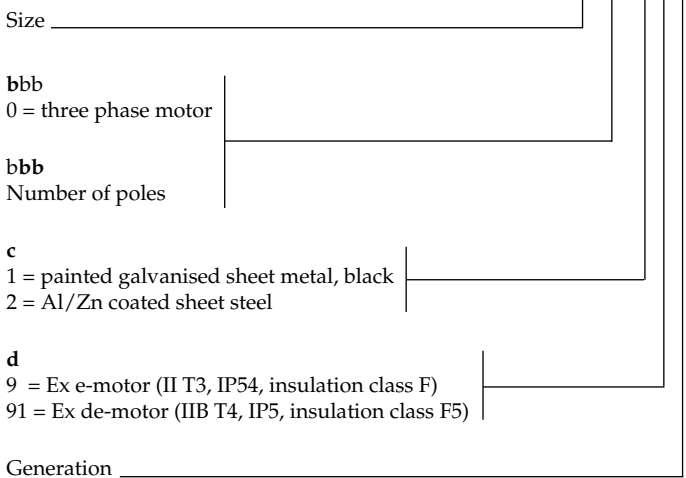

## Dimensional drawing

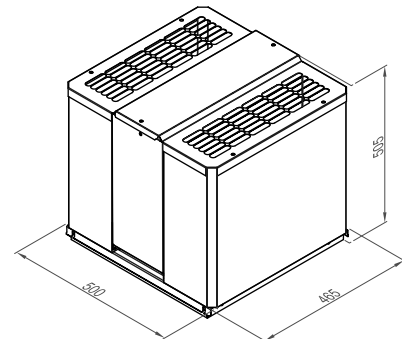

Weight 31 kg

Roof curb	BOGA-02-2-1-1
Inlet sound attenuator	STEZ-07-2
Safety switch	SAFE-4-0-0
Frequency converter (see motor table)	STYR-aa-b-S-0-1

# STEF-3

## STEF-3-004

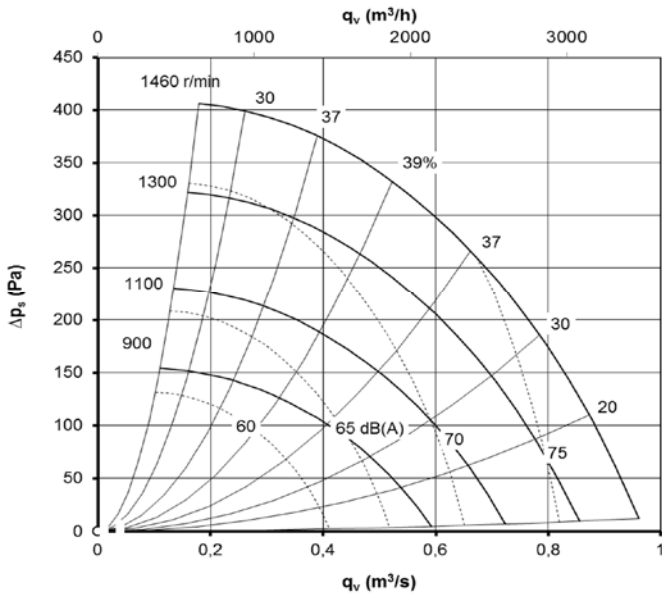

## STEF-3-006

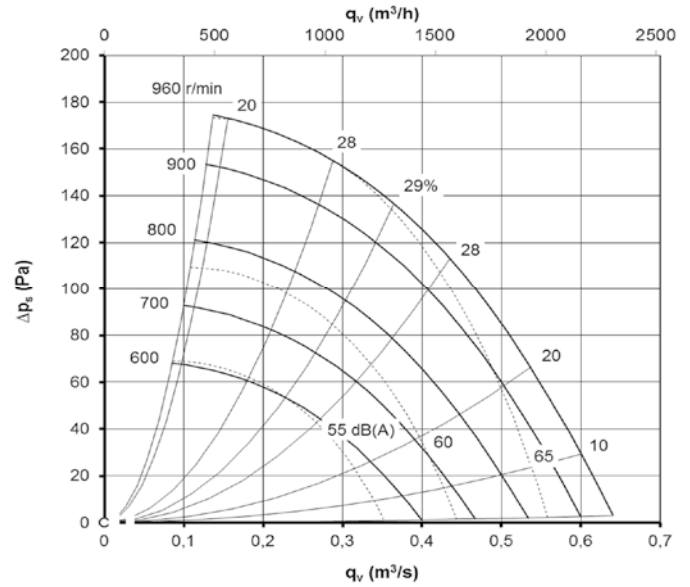

### Sound data

				Correction Kocf (dB)							
				Octave band mid-frequency (Hz)							
Fan code	Sound path	MinRPM	MaxRPM	63	125	250	500	1000	2000	4000	8000
STEF-3	Surroundings	0	1500	-8	3	6	-4	-8	-13	-17	-16
STEF-3	To the inlet duct	0	1500	-9	-6	-6	-6	-6	-10	-15	-19

### Motor data

Motor nominal data at 50 Hz							
Fan code	Speed	Output	Voltage	Current	STYR-	STYR-	
STEF-	r/min	kW	V	(A)	1~ 230 V	3~ 400V	
Flameproof enclosure design Ex de IIB T4, IP 5 insulation class F5							
3-004-c-91-5	1421	0,55	400 VY	1,4	STYR-16-1-S-d-1	STYR-16-3-S-d-1	
3-006-c-91-5	953	0,37	400 VY	1,3	STYR-14-1-S-d-1	STYR-14-3-S-d-1	
Increased safety design E xe II T3, IP 54 insulation class F							
3-004-c-9-5	1380	0,55	400 VY	1,4	-	-	
3-006-c-9-5	920	0,37	400 VY	1,3	-	-	

### Roof Fan

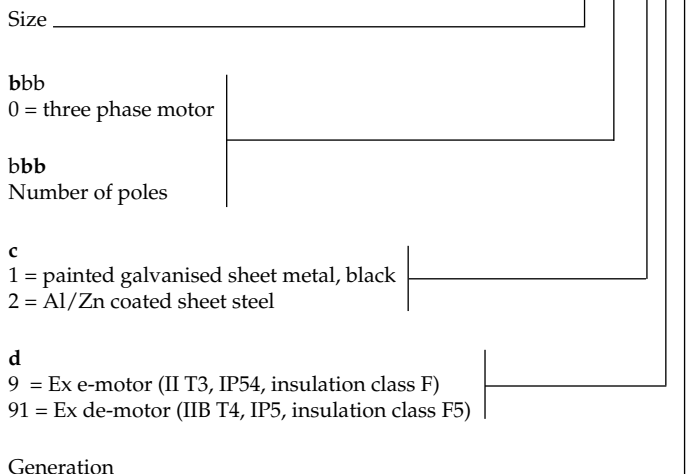

### Dimensional drawing

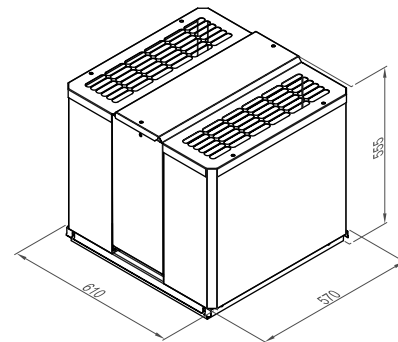

Weight 45 kg

Roof curb	BOGA-03-2-1-1
Inlet sound attenuator	STEZ-07-3
Safety switch	SAFE-4-0-0
Frequency converter (see motor table)	STYR-aa-b-S-0-1

# STEF-4

## STEF-4-004

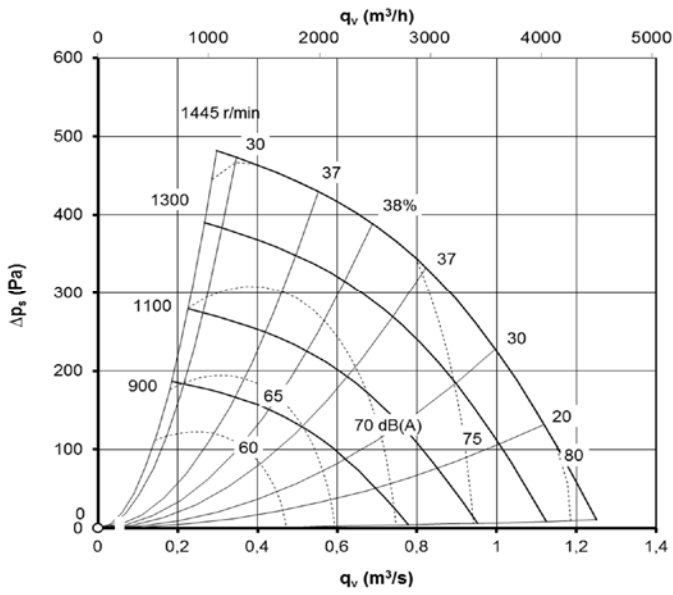

## STEF-4-006

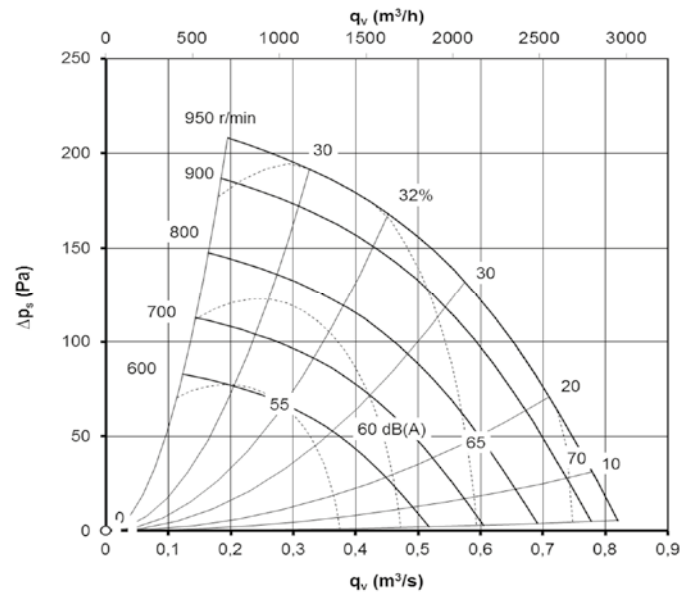

### Sound data

				Correction Kocf (dB)							
				Octave band mid-frequency (Hz)							
Fan code	Sound path	MinRPM	MaxRPM	63	125	250	500	1000	2000	4000	8000
STEF-4	Surroundings	0	1500	-8	3	6	-5	-10	-15	-20	-25
STEF-4	To the inlet duct	0	1500	-8	-6	-8	-7	-5	-10	-17	-22

### Motor data

Motor nominal data at 50 Hz							
Fan code	Speed	Output	Voltage	Current	STYR-	STYR-	
STEF-	r/min	kW	V	(A)	1~ 230 V	3~ 400V	
Flameproof enclosure design Ex de IIB T4, IP 5 insulation class F5							
4-004-c-91-5	1413	1,5	400 VY	1,8	STYR-16-1-S-d-1	STYR-16-3-S-d-1	
4-006-c-91-5	953	0,37	400 VY	1,3	STYR-14-1-S-d-1	STYR-14-3-S-d-1	
Increased safety design Ex e II T3, IP 54 insulation class F							
4-004-c-9-5	1390	1,5	400 VY	1,8	-	-	
4-006-c-9-5	920	0,37	400 VY	1,3	-	-	

### Roof Fan

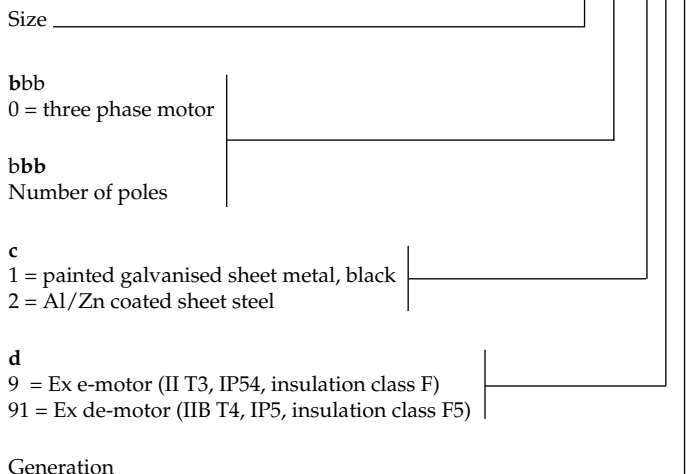

### Dimensional drawing

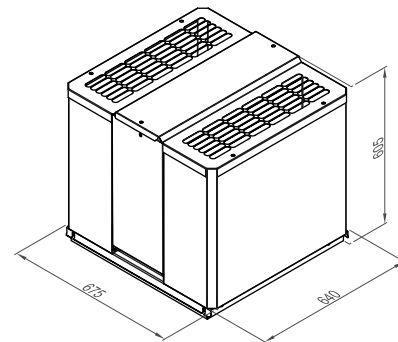

Weight 50 kg

Roof curb	BOGA-04-2-1-1
Inlet sound attenuator	STEZ-07-4
Safety switch	SAFE-4-0-0
Frequency converter (see motor table)	STYR-aa-b-S-0-1

# STEP-5

## STEP-5-004

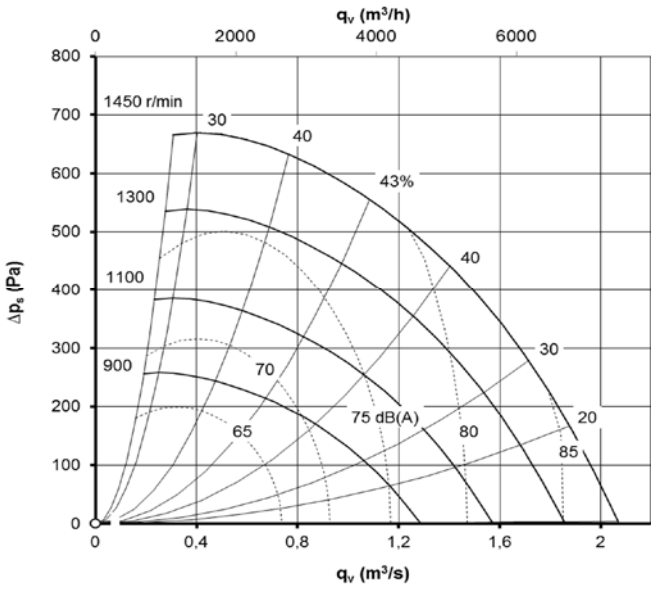

## STEP-5-006

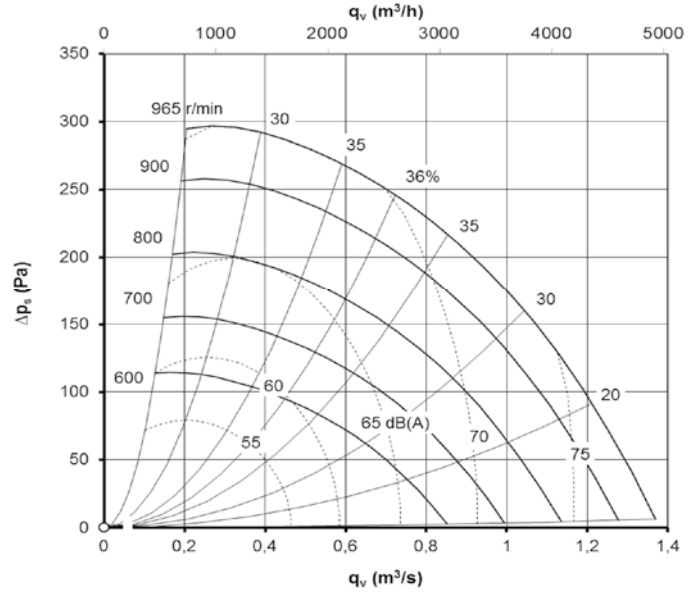

### Sound data

				Correction Koct (dB)							
				Octave band mid-frequency (Hz)							
Fan code	Sound path	MinRPM	MaxRPM	63	125	250	500	1000	2000	4000	8000
STEP-5	Surroundings	0	1500	-8	3	6	-5	-12	-16	-19	-22
STEP-5	To the inlet duct	0	1500	-11	-7	-8	-9	-11	-11	-18	-25

### Motor data

Motor nominal data at 50 Hz							
Fan code	Speed	Output	Voltage	Current	STYR-	STYR-	
STEP-	r/min	kW	V	(A)	1~ 230 V	3~ 400V	
Flameproof enclosure design Ex de IIB T4, IP 5 insulation class F5							
5-004-c-91-5	1431	1,5	400 VY	3,3	STYR-18-1-S-d-1	STYR-18-3-S-d-1	
5-006-c-91-5	953	0,37	400 VY	1,3	STYR-16-1-S-d-1	STYR-16-3-S-d-1	
Increased safety design Ex e II T3, IP 54 insulation class F							
5-004-c-9-5	1410	1,5	400 VY	3,3	-	-	
5-006-c-9-5	920	0,37	400 VY	1,3	-	-	

### Roof Fan

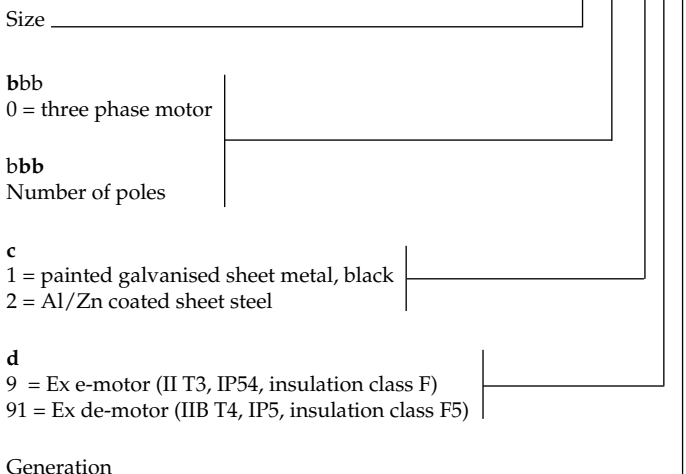

### Dimensional drawing

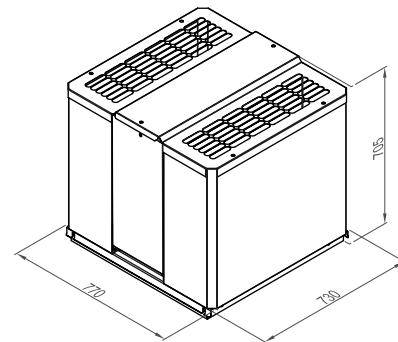

Weight 66 kg

Roof curb	BOGA-05-2-1-1
Inlet sound attenuator	STEZ-07-5
Safety switch	SAFE-4-0-0
Frequency converter (see motor table)	STYR-aa-b-S-0-1

# STEF-6

STEF-6-006

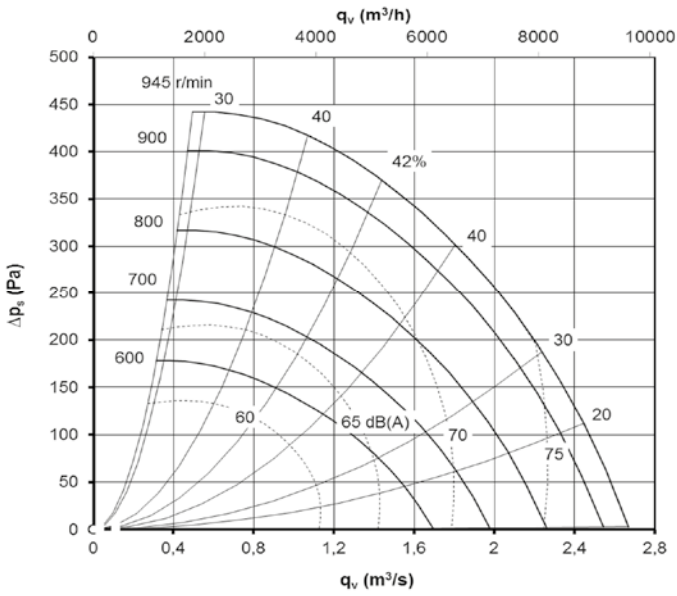

## Sound data

				Correction Kocf (dB)							
				Octave band mid-frequency (Hz)							
Fan code	Sound path	MinRPM	MaxRPM	63	125	250	500	1000	2000	4000	8000
STEF-6	Surroundings	0	1500	3	8	3	-2	-8	-12	-15	-21
STEF-6	To the inlet duct	0	1500	3	6	1	-2	-7	-7	-12	-15

## Motor data

Motor nominal data at 50 Hz						
Fan code	Speed r/min	Output kW	Voltage V	Current (A)	STYR-1~230 V	STYR-3~400V
Flameproof enclosure design Ex de IIB T4, IP 5 insulation class F5						
6-006-c-91-5	940	1,1	400 VY	3,25	STYR-18-1-S-d-1	STYR-18-3-S-d-1
Increased safety design Ex e II T3, IP 54 insulation class F						
6-006-c-9-5	940	1,1	400 VY	3,25	-	-

### Roof Fan

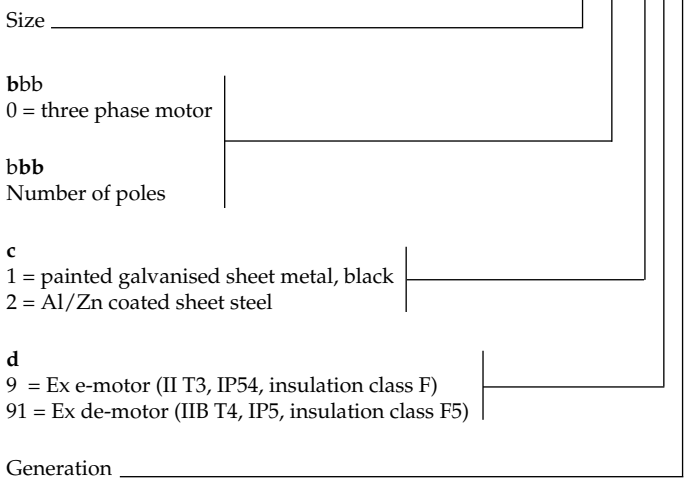

### Dimensional drawing

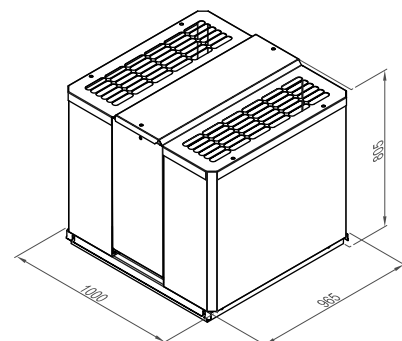

Weight 116 kg

Roof curb	BOGA-06-2-1-1
Inlet sound attenuator	STEZ-07-6
Safety switch	SAFE-4-0-0
Frequency converter (see motor table)	STYR-aa-b-S-0-1

# STEF-7

STEF-7-006

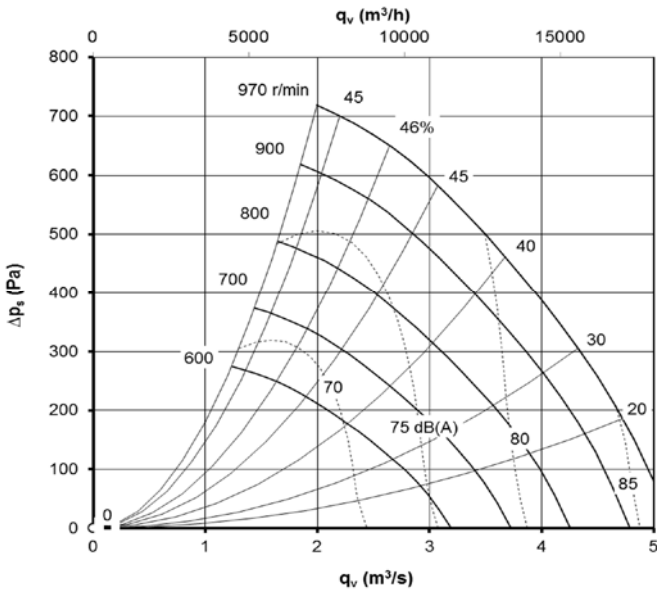

## Sound data

				Correction Kocf (dB)							
				Octave band mid-frequency (Hz)							
Fan code	Sound path	MinRPM	MaxRPM	63	125	250	500	1000	2000	4000	8000
STEF-7	Surroundings	0	1500	3	7	3	-3	-7	-12	-15	-21
STEF-7	To the inlet duct	0	1500	1	3	5	1	-2	-4	-10	-15

## Motor data

Motor nominal data at 50 Hz							
Fan code	Speed	Output	Voltage	Current	STYR-	STYR-	
STEF-	r/min	kW	V	(A)	1~ 230 V	3~ 400V	
Flameproof enclosure design Ex de IIB T4, IP 5 insulation class F5							
7-006-c-91-5	967	4	400 VY	9,3	-	STYR-21-3-S-d-1	
Increased safety design E xe II T3, IP 54 insulation class F							
7-006-c-9-5	963	4	400 VY	9,3	-	-	

## Roof Fan

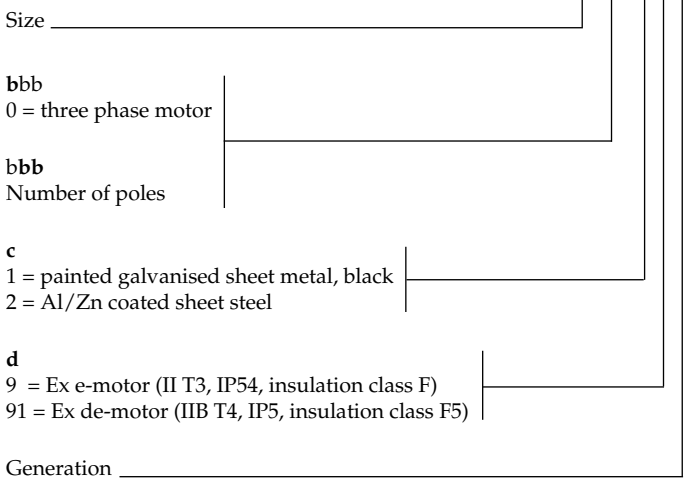

## Dimensional drawing

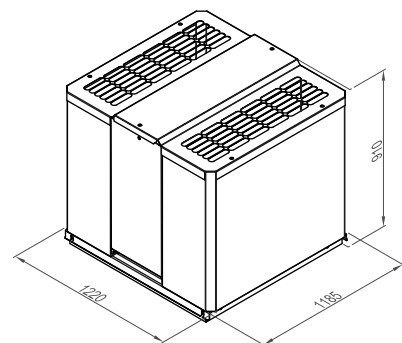

Weight 116 kg

Roof curb	BOGA-07-2-1-1
Inlet sound attenuator	STEZ-07-7
Safety switch	SAFE-4-0-0
Frequency converter (see motor table)	STYR-aa-b-S-0-1

# Accessories

## BOGA roof curb with insulation

The BOGA consists of a sheet steel duct, insulated on the inside with 50 mm (in standard EI30 version) thick mineral wool mat.. The insulation is backed with perforated sheet metal. The duct is equipped with two cable glands and one built-in cable conduit which can accommodate two cables for electrical connection to the power roof ventilator. Adjustable mounting brackets, which can be set to suit the pitch of the roof, are fitted to the outside of the roof duct. The roof fan is secured by means of four screws through holes in the sides of the base plate.

The BOGA is made of aluminium and zinc coated sheet steel. The check damper blades are made of aluminium. BOGA versions c = 3 and c = 8 are to be used if the roof fan is supplied with FLOW or STEZ-03.

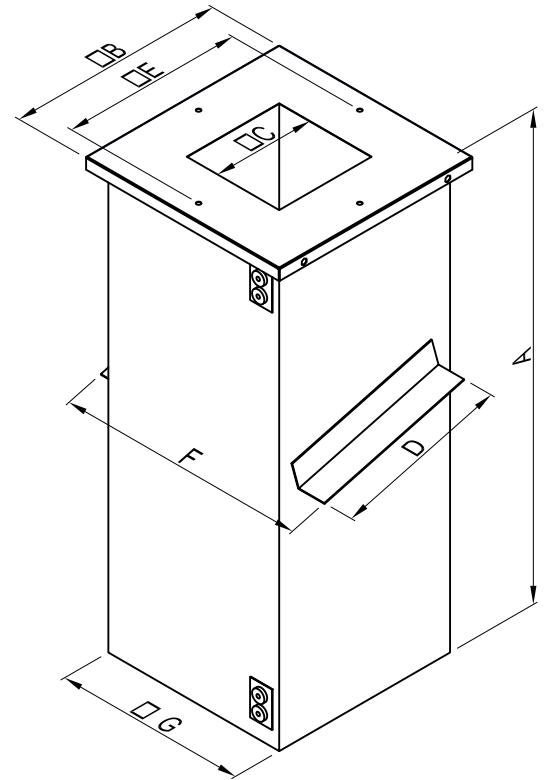

### Roof duct

BOGA - (a)aa - b - c - 1

Size \_\_\_\_\_  
(005, 01, 02, 03, 04, 05, 06, 07)

Back draught damper \_\_\_\_\_

1 = with shutter  
2 = w/o shutter

Model \_\_\_\_\_

1= 980 mm, EI30, 50 mm insulation  
3= 980 mm, EI30, 50 mm Insulation (with FLOW or STEZ-03)  
2= 1250 mm, EI30, 50 mm insulation  
8= 1250 mm, EI30, 50 mm insulation (with FLOW or STEZ-03)  
4= 1250 mm, EI60, 100 mm insulation  
6= 1250 mm, EI120, 150 mm insulation

Generation \_\_\_\_\_

## Dimensions and weight

### EI30, 50 mm insulation

Modell	A1	A2	B	C	D	E	F	G	W1 (kg)	W2 (kg)
BOGA-01-b-c-1	980	1250	442	211	310	368	485	325	18	22
BOGA-02-b-c-1	980	1250	442	211	310	368	485	325	18	22
BOGA-03-b-c-1	980	1250	552	435	530	468	705	545	43	53
BOGA-04-b-c-1	980	1250	622	435	530	498	705	545	43	53
BOGA-05-b-c-1	980	1250	712	435	530	573	705	545	43	53
BOGA-06-b-c-1	980	1250	892	768	870	800	1040	880	85	105
BOGA-07-b-c-1	980	1250	1112	768	870	853	1040	880	85	105

W1 = Weight in kg for A1  
W2 = Weight in kg for A2

### EI60, 100 mm insulation

Modell	A	B	C	D	E	F	G	W (kg)
BOGA-01-b-4-1	1228	429	211	385	369	586	429	41
BOGA-02-b-4-1	1228	429	211	385	369	586	429	41
BOGA-03-b-4-1	1228	653	435	605	479	810	653	69
BOGA-04-b-4-1	1228	653	435	605	549	810	653	69
BOGA-05-b-4-1	1228	653	435	605	590	810	653	69
BOGA-06-b-4-1	1228	986	768	940	819	1143	986	111
BOGA-07-b-4-1	1228	986	768	940	900	1143	986	111

### EI120, 150 mm insulation

Modell	A	B	C	D	E	F	G	W (kg)
BOGA-01-b-6-1	1228	529	211	485	369	686	529	71
BOGA-02-b-6-1	1228	529	211	485	369	686	529	71
BOGA-03-b-6c-1	1228	753	435	705	479	910	753	113
BOGA-04-b-6-1	1228	753	435	705	549	910	753	113
BOGA-05-b-6-1	1228	753	435	705	590	910	753	113
BOGA-06-b-6-1	1228	1086	768	1040	819	1243	1086	178
BOGA-07-b-6-1	1228	1086	768	1040	900	1243	1086	178

# Accessories

BOGA roof curb with insulation, cont.

Sound attenuation when using BOGA L=980

Model	Octave band mid frequency (Hz)							
	63	125	250	500	1000	2000	4000	8000
BOGA-01-b-c-1	-1	-2	-3	-11	-19	-15	-13	-9
BOGA-02-b-c-1	-1	-2	-3	-11	-19	-15	-13	-9
BOGA-03-b-c-1	0	-1	-2	-9	-16	-13	-11	-8
BOGA-04-b-c-1	0	-1	-2	-9	-16	-13	-11	-8
BOGA-05-b-c-1	0	-1	-2	-9	-16	-13	-11	-8
BOGA-06-b-c-1	0	-2	-3	-8	-13	-11	-9	-7
BOGA-07-b-c-1	0	-2	-3	-8	-13	-11	-9	-7

Sound attenuation when using BOGA L=1250

Model	Octave band mid frequency (Hz)							
	63	125	250	500	1000	2000	4000	8000
BOGA-01-b-c-1	-3	-4	-5	-14	-22	-19	-15	-11
BOGA-02-b-c-1	-3	-4	-5	-14	-22	-19	-15	-11
BOGA-03-b-c-1	-2	-3	-4	-12	-19	-16	-13	-9
BOGA-04-b-c-1	-2	-3	-4	-12	-19	-16	-13	-9
BOGA-05-b-c-1	-2	-3	-4	-12	-19	-16	-13	-9
BOGA-06-b-c-1	-1	-3	-6	-12	-15	-12	-10	-8
BOGA-07-b-c-1	-1	-3	-6	-12	-15	-12	-10	-8

# Accessories

## Inlet sound attenuator STEZ-07

The STEZ-07 sound attenuator is used to attenuate the sound level to the duct. It is made of aluminium and zink coated sheet steel. The baffles are made of mineral wool and covered by fibre glass film.

The inlet of the sound attenuator is square. If the sound attenuator is supposed to be connected to a round duct, a separate mounting plate STEZ-04, is available. STEZ-04 is mounted under the STEZ-07.

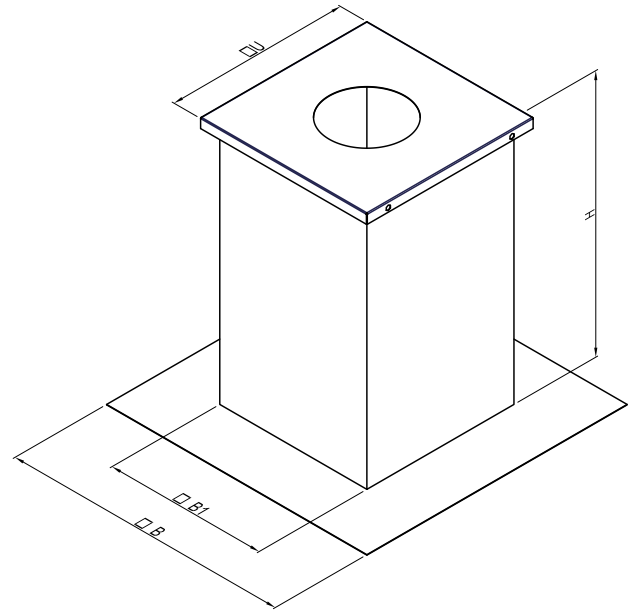

Model	B	B1	U	H	Weight [kg]
STEZ-07-1	690	390	442	660	15
STEZ-07-2	690	390	442	660	15
STEZ-07-3	803	503	552	760	35
STEZ-07-03	803	503	552	760	35
STEZ-07-4	873	573	622	760	40
STEZ-07-5	963	663	712	960	45
STEZ-07-6	1133	833	892	960	60
STEZ-07-06	1133	833	892	960	60
STEZ-07-7	1363	1063	1112	960	80

## Sound attenuation when using STEZ-07

Model	Octave band mid frequency (Hz)							
	63	125	250	500	1000	2000	4000	8000
STEZ-07-1	-1	-2	-4	-9	-13	-20	-21	-12
STEZ-07-2	-1	-2	-4	-9	-13	-20	-21	-12
STEZ-07-3/03	-1	-2	-6	-9	-15	-18	-18	-11
STEZ-07-4	-1	-2	-6	-9	-16	-19	-19	-12
STEZ-07-5	-1	-3	-8	-14	-18	-24	-25	-23
STEZ-07-6/06	-1	-3	-8	-14	-18	-24	-25	-23
STEZ-07-7	-1	-2	-7	-13	-16	-22	-23	-20

## Pressure loss [Pa]

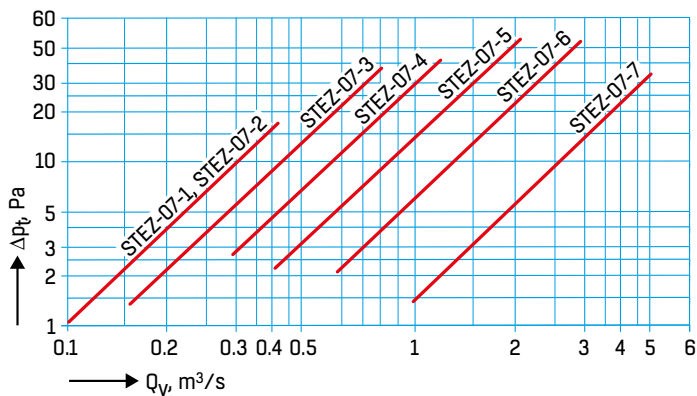

# Accessories

## Safety switch SAFE

The safety isolation switch has been tested to IEC 947-3.  
It is available in ATEX version and must be delivered loose.

**Safety isolation switch** **SAFE-4-0-0**

4 = ATEX-version, 3-pole with auxiliary contact \_\_\_\_\_

0 = delivered loose \_\_\_\_\_

Version \_\_\_\_\_

0



## Frequency converter STYR

**Frequency converter** **STYR-aa-b-S-0-1**

Size \_\_\_\_\_

13...21  
(See STYR code in the attached table  
or in the motor table)

1 = single-phase supply 230 V \_\_\_\_\_

3 = three-phase supply 400V \_\_\_\_\_

Max. cable length 15 m \_\_\_\_\_  
(cable is not included in the delivery)

0 = delivered loose \_\_\_\_\_

e = 1 \_\_\_\_\_



Roof fan	Frequency converter 3-phase STYR-code	Frequency converter 1-phase STYR-code	Max. frequency Hz
STEF-1-004-c-9-5	STYR-14-3-S-d-1	STYR-13-1-S-d-1	60
STEF-2-004-c-9-5	STYR-14-3-S-d-1	STYR-13-1-S-d-1	52
STEF-2-006-c-9-5	STYR-14-3-S-d-1	STYR-14-1-S-d-1	60
STEF-3-004-c-9-5	STYR-16-3-S-d-1	STYR-16-1-S-d-1	55
STEF-3-006-c-9-5	STYR-14-3-S-d-1	STYR-14-1-S-d-1	56
STEF-4-004-c-9-5	STYR-16-3-S-d-1	STYR-16-1-S-d-1	54
STEF-4-006-c-9-5	STYR-14-3-S-d-1	STYR-14-1-S-d-1	56
STEF-5-004-c-9-5	STYR-18-3-S-d-1	STYR-18-1-S-d-1	54
STEF-5-006-c-9-5	STYR-16-3-S-d-1	STYR-16-1-S-d-1	58
STEF-6-006-c-9-5	STYR-18-3-S-d-1	STYR-18-1-S-d-1	50
STEF-7-006-c-9-5	STYR-21-3-S-d-1	-	50
STEF-7-008-c-9-5	STYR-19-3-S-d-1	-	55

# Wiring

## Star connection

Three phase motor, single speed

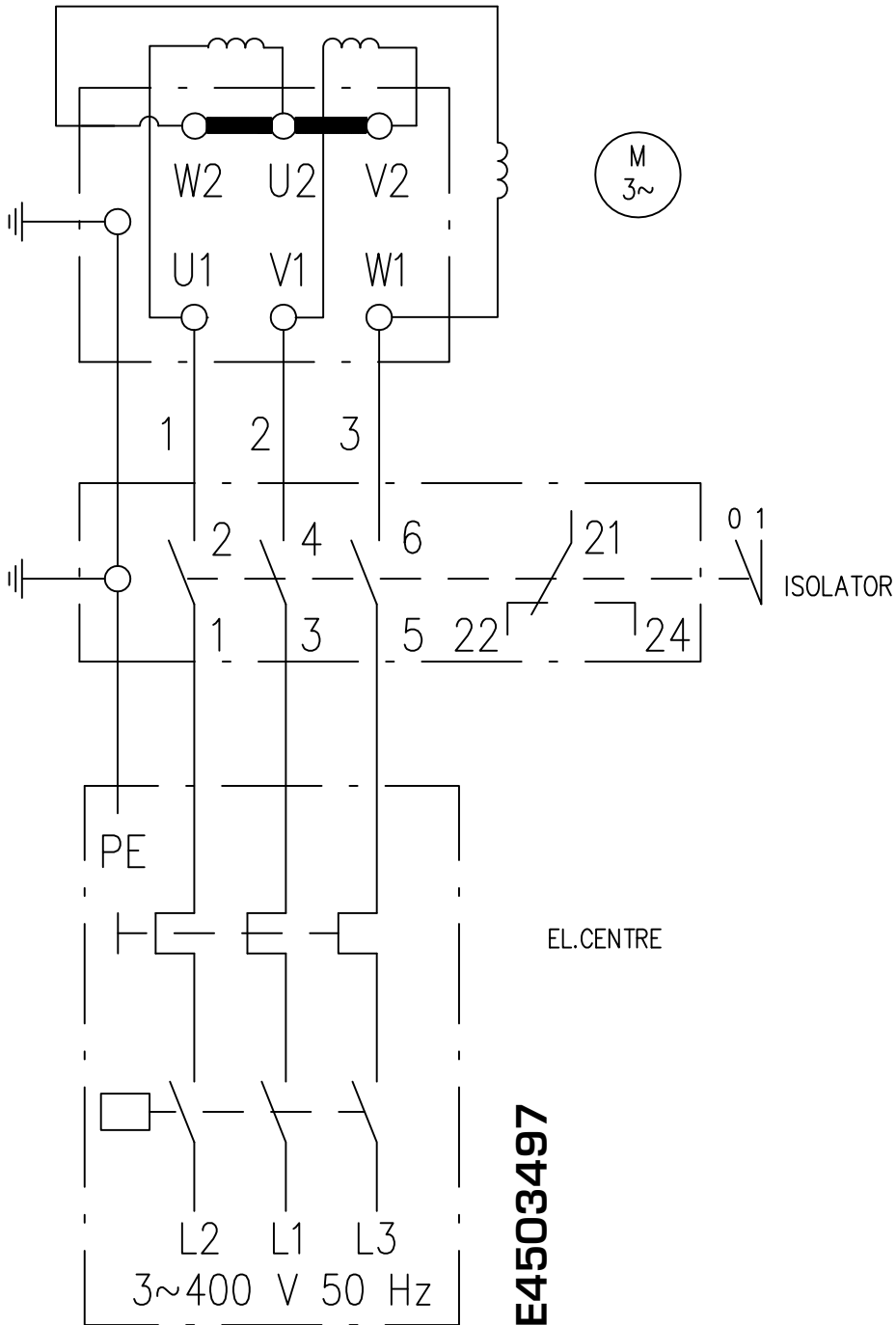

# Important information

Information that the end-user/client **must** provide to their fan manufacturer (Fläkt Woods) so that they can supply you with a fan which is compliant with the ATEX Directive 94/9/EC.

## Hazardous Area Detail

		Inside fan casing	Outside fan casing
Gas Zone Classification	Zone 0 (cat. 1G)	Not Available	Not Available
	Zone 1 (cat. 2G)	<input type="checkbox"/>	<input type="checkbox"/>
	Zone 2 (cat. 3G)	<input type="checkbox"/>	<input type="checkbox"/>
	No classification	<input type="checkbox"/>	<input type="checkbox"/>
Dust Zone Classification	Zone 20 (cat. 1D)	Not Available	Not Available
	Zone 21 (cat. 2D)	<input type="checkbox"/>	<input type="checkbox"/>
	Zone 22 (cat. 3D)	<input type="checkbox"/>	<input type="checkbox"/>
	No classification	<input type="checkbox"/>	<input type="checkbox"/>

## Operation and fluid detail

Ambient temperature  °C

Inlet temperature  °C

Gas	Self-ignition temperature: <input type="text"/> °C	Explosion group: <input type="checkbox"/> IIA <input type="checkbox"/> IIB <input type="checkbox"/> IIC
	Type of Gas: <input type="text"/>	

Dust	Self-ignition temperature of dust clouds <input type="text"/> °C
	Self-ignition temperature of a 5 mm layer of dust <input type="text"/> °C
	<input type="checkbox"/> Conductive dust <input type="checkbox"/> Non conductive dust

Oxygen rate in gas > 21%	<input type="checkbox"/> NO <input type="checkbox"/> YES <i>out of EN14986 scope, needs a special approval of our Technical Director</i>
--------------------------	---

Installation conditions	Inlet <input type="checkbox"/> free <input type="checkbox"/> ducted
	Outlet <input type="checkbox"/> free <input type="checkbox"/> ducted

## Information on motor type and its conditions of work

Temperature class (Gas)	T1	T2	T3	T4	T5	T6
Maximum surface temperature (°C)	450	300	200	135	100	85
	<input type="checkbox"/>	<input type="checkbox"/>	<input type="checkbox"/>	<input type="checkbox"/>	<input type="checkbox"/>	<input type="checkbox"/>

Variable frequency drive:  NO  YES if YES, duty range: from ..... to ..... Hz

<b>Date and the seal of the company</b>	<b>Name</b>
	<b>Signature</b>

# WE BRING BETTER AIR™ TO LIFE

With over a century of innovation and expertise to share with our customers, Fläkt Woods is a global leader in Air Technology products and solutions. We specialize in the design and manufacturing of a wide range of products and solutions for Air Movement, Air Treatment, Air Distribution, Air Management and Air Diffusion with focus on two major benefits – **Air Comfort** and **Fire Safety**. With market presence in 65 countries we are in a unique position to be a local supplier and an international partner in our customer's projects.

Our product brands such as SEMCO®, eQ®, eQ Prime®, JM Aerofoil®, Econet®, Veloduct®, Optivent®, Optimix®, Econovent® and Clean-vent® are well-known and trusted by customers all over the world to deliver high quality and energy efficient solutions.



Manufacturer:

**Fläkt Woods Oy**

Kalevantie 39, FI-20520 Turku, Finland

Tel. +358 20 4423000

email [info@flaktwoods.com](mailto:info@flaktwoods.com) [www.flaktwoods.com](http://www.flaktwoods.com)

» To learn more about our offering and get in contact with your nearest sales representative please visit [www.flaktwoods.com](http://www.flaktwoods.com)

[WWW.FLAKTWOODS.COM](http://WWW.FLAKTWOODS.COM)

ROOFMASTER STEF-ATEX | 9551GB | 20150423