

C A M B R I D G E
FIRE RESEARCH

REPORT NUMBER
CFR1104142/01

FIRE RESISTANCE TEST
IN ACCORDANCE WITH BS EN 1366-3:2009 ANNEX A.2

Sponsors:	Northern Fire Engineering Ltd	Firewise Supplies Ltd
Address:	40 Crompton Road Heaton Newcastle upon Tyne NE6 5QL	Unit 5, The Old Brewery Brewery Road Pampisford Cambridge CB22 3EW
Date of test:	14 th April 2011	

Results:	
Test duration:	182 minutes (discontinued at the request of the sponsors)
Integrity:	
Sustained flaming:	131 minutes
Gap gauge:	182 minutes no failure (the test having been discontinued)
Cotton Pad:	182 minutes no failure (the test having been discontinued)
Insulation:	52 minutes

	<p>Summary of test specimen C:</p> <p>A large cable penetration seal comprising NFEL FR pillows fitted within a 600 x 600 mm aperture, was tested as one of five specimens of which only one is covered by this report.</p>
--	--



0 CONTENTS PAGE

0 CONTENTS PAGE	2
1 PREPARATION FOR TESTING	3
1.1 Specimen conditioning	3
1.2 Supporting construction	3
1.5 Specimen verification	4
1.6 Installation of penetration seal	4
1.7 Additional loading	4
1.8 Specimen sampling	4
2 TEST CONDITIONS, INSTRUMENTATION AND MEASURING	5
2.1 Furnace temperature	5
2.2 Furnace pressure	6
3.3 Ambient temperature	6
2.4 Unexposed face specimen thermocouples	7
3 TEST OBSERVATIONS	8
4 LIMITATIONS	11
APPENDIX 1 SPECIMEN CONSTRUCTION	12
Appendix 1 Table 1	12
Appendix 1 Figure 1 – Elevation viewed from the unexposed side	19
Appendix 1 Figure 2 – Side Elevation	20
APPENDIX 2 PHOTOGRAPHS	21
Appendix 2.1 Pre-test photos	21
Appendix 2.2 During test photos	24
APPENDIX 3 POSITIONING OF INSTRUMENTATION	29
APPENDIX 4 RECORDED THERMOCOUPLE DATA	30

1 PREPARATION FOR TESTING

1.1 Specimen conditioning

The specimen components were at Cambridge Fire Research for a total period of 8 days, during which time they were stored, surveyed and prepared for testing. For this duration the temperature and relative humidity were measured and recorded within the range of 10.2 to 20.9 °C and 38 to 65% respectively.

1.2 Supporting construction

Cambridge Fire Research installed a rigid wall supporting construction comprising 150 mm thick Celcon standard blocks and mortar incorporating apertures for the test specimens. The apertures were positioned such that each specimen would be at least 215 mm from any other and the internal surfaces of the furnace. The penetration aperture for this specimen (specimen C) was 600 high x 600 wide.

1.3 Service support construction

Cambridge Fire Research installed the service support construction as detailed in Appendix 1 Table 1.

The strut assembly was in accordance with the test arrangement shown in Figures A.2 and A.8 of the test standard, providing a support position for ladders and trays at 350 mm from the surface of the wall on both the exposed and unexposed side, specified by the sponsors.

The arrangement of ladders and trays was generally in accordance with Figure A.1 of the test standard, except for some dimensional differences in the ladders and perforated tray. They were installed using the minimum working spaces as specified by the sponsors and as shown in Appendix 1 Figure 1.

1.4 Installation of services

Cambridge Fire Research installed the cables, as detailed in Appendix 1 Table 1 and Figure 1. This was generally in accordance with Figure A.1 of the test standard but with differences in the specification of the cables when compared to Table A.1 of the test standard.

1.5 Specimen verification

Cambridge Fire Research carried out a detailed survey of the specimen to verify the information provided by the sponsors. This included verifying the weight, materials and dimensions of construction components wherever possible.

Details and drawings of the construction are shown in Appendix 1.

Photographs of details of the construction taken before the test are shown in Appendix 2.

1.6 Installation of penetration seal

The penetration seal was installed by Northern Fire Engineering Ltd.

1.7 Additional loading

In accordance with the test standard, an additional load of 22 kg was calculated as being required at each cable support.

This additional load was applied, by means of steel ballast weights, attached to the underside of the service support at the position of the support 350 mm from the exposed surface of the wall only.

1.8 Specimen sampling

Cambridge Fire Research was not involved in any selection or sampling procedures for the tested specimens.

Cambridge Fire Research was advised that specimen sampling had been carried out by Warrington Certification and provided with a copy of their sample report, dated 08/10/10 and WCL job number 196883. The cling film of each package was marked with a signature, which matched the sample report signature. A photograph of this signature is included in Appendix 2.

2 TEST CONDITIONS, INSTRUMENTATION AND MEASURING

2.1 Furnace temperature

Furnace temperature was controlled so as to follow the standard temperature/time curve defined in the test standard and within the tolerances permitted. The furnace mean temperature was calculated from the output recorded using four furnace thermocouples of the design specified in the test standard. The following graph shows the standard and mean furnace temperature/time data.

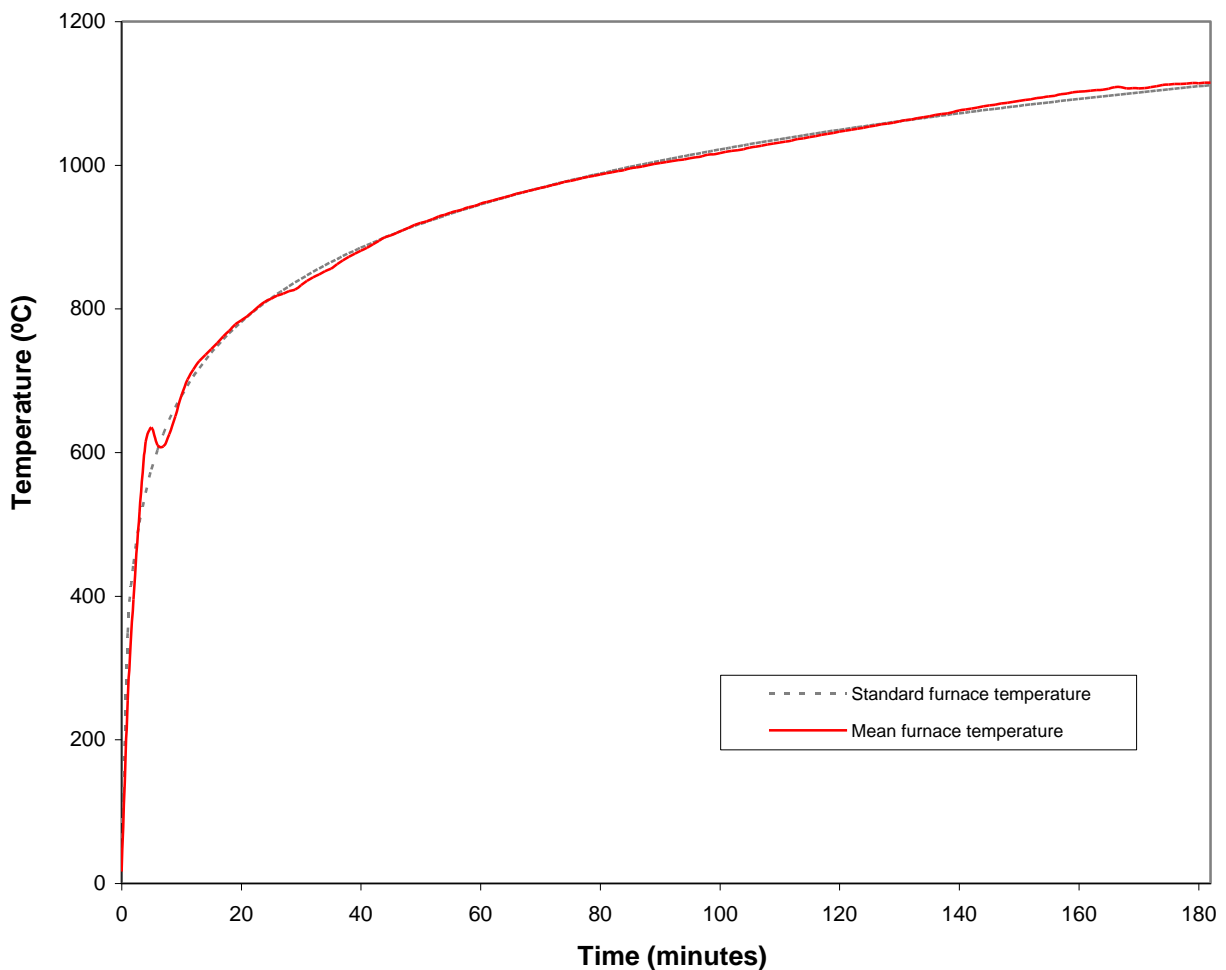

2.2 Furnace pressure

Furnace pressure was maintained for the duration of the test at a nominal + 23.5 Pa measured at the pressure sensing head. When a linear pressure gradient of 8.5 Pa/m is applied this equates to + 20 Pa at the top of the penetration for specimen C. The furnace pressure was controlled within the tolerances permitted in the test standard. The following graph shows the actual and desired furnace pressure/time data.

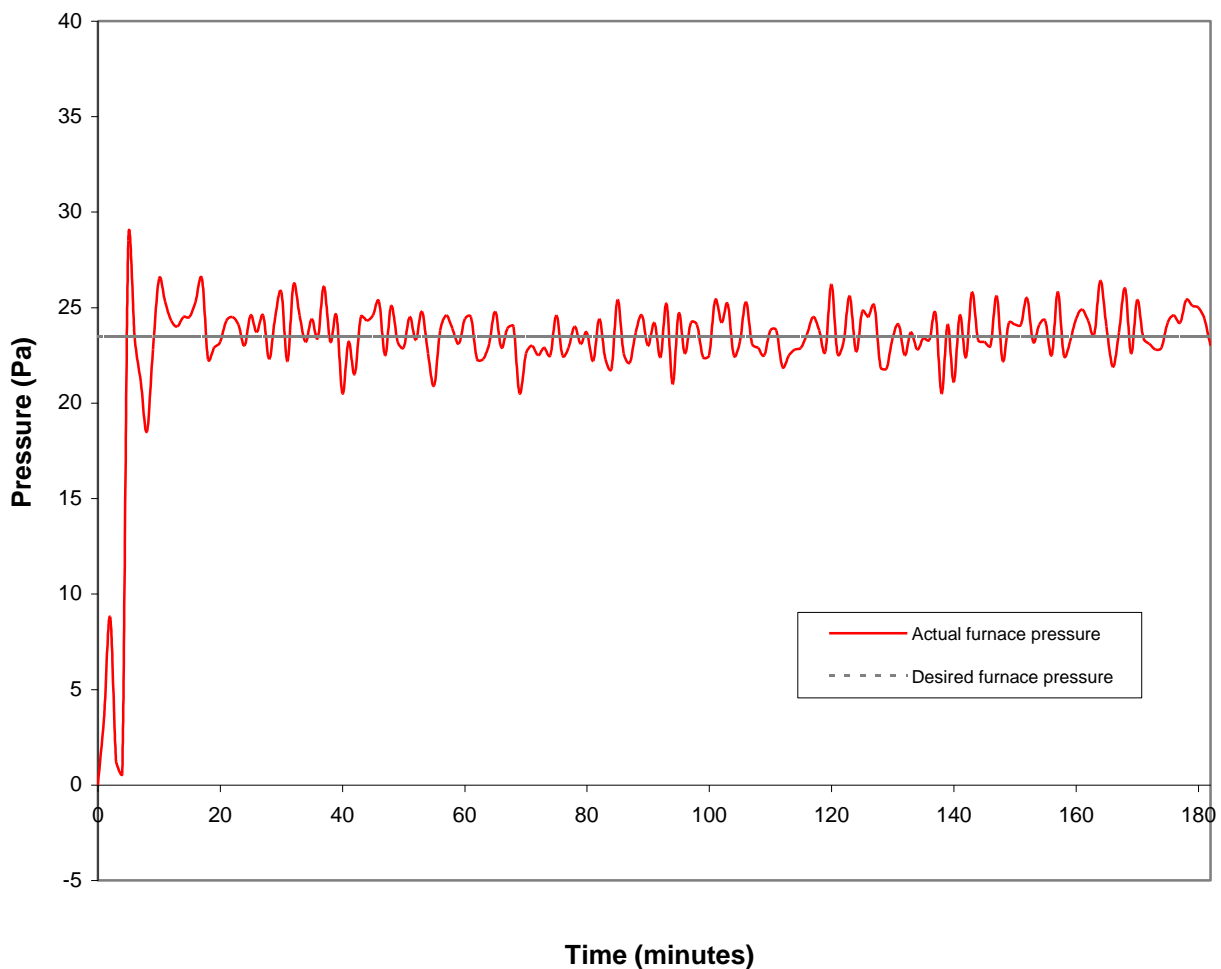

3.3 Ambient temperature

Ambient temperature at the start of the test was 16 °C.
Ambient temperature ranged between 15 °C and 16 °C during the test.

2.4 Unexposed face specimen thermocouples

Surface temperature measuring thermocouples of the design specified in the test standard were affixed to the unexposed face of the specimen to monitor the temperature rise as follows:

Specimen C: Channels 16 to 42 (maximum only)

The positions of these thermocouples are shown in Appendix 3. The table below categorises the thermocouples into position types A, B, D and E defined in the test standard.

Position Type	Channel Number
A	16, 18, 20, 24, 28, 30, 32, 36, 38 and 40
B	17, 19, 21, 22, 25, 29, 31, 33, 35, 37, 39 and 41
D	26, 27, 34 and 42
E	23

A roving thermocouple was available for measurement of any specific hotspots and was recorded on Channel 15. Any position(s) of use of the roving thermocouple are noted in the observations in Section 3.

The recorded data of all individual thermocouples is shown in the tables in Appendix 4.

3 TEST OBSERVATIONS

Photographs taken during and after the test are shown in Appendix 2.

TEST OBSERVATIONS (E = Exposed face: U = Unexposed face)		
Time (min:sec)	Face	Observation
00:00		Start of the test.
00:50	E	Glowing of the cables is apparent.
01:05	U	Smoke/steam issues at the unexposed ends of the cables in the bottom tray.
02:20	U	Smoke/steam issuing at the unexposed ends of the cables in the bottom tray has decreased, and smoke/steam issues at various positions on the specimen. Gaps between the pillows have not closed up.
04:00	E	Distortion of the service support construction is apparent.
04:30	U	Smoke/steam issuing has increased in density.
06:50	E	Blue flames are apparent.
07:30	U	Smoke/steam issuing has decreased in density.
13:00	U	Various gaps remain between the pillows. Furnace glowing is visible through these at some positions, particularly adjacent to the top ladders.
17:45	E	Distortion of the service support construction has developed.
22:00	U	Some gaps between components remain. Twisting of the top right hand ladder is apparent and no longer rests on the strut assembly on the right hand side.
27:30	E	The strut assembly for the middle tray has bowed, partially collapsed and rests on the bottom tray.
36:00	E	All service support construction components have bowed, with the top and middle components resting on the components below.
45:30	E	Distortion of the bottom tray has developed.
47:00	U	A sporadic jet of flame is apparent at a gap between the pillow and the left hand vertical edge of the top left ladder.
48:58	U	A reduced size cotton pad is applied to the surface of the pillows, below the middle tray.
49:28	U	The cotton pad is removed (no failure).
53:00	U	INSULATION FAILURE is deemed to have occurred with a result of 52 minutes due to the unexposed face temperature exceeding the maximum temperature rise criteria.
54:00	U	Smoke/steam continues to issue from various positions, mainly in the region to the top ladders and middle tray.
59:59	U	A cotton pad is applied to the wall over the interface with the pillows and a visible gap between the pillows, above the right hand top ladder.
60:29	U	The cotton pad is removed (no failure).
62:32	U	A cotton pad is applied to the interface between the wall and the upper surface of the pillows, above the left hand top ladder.
63:03	U	The cotton pad is removed (no failure).

64:07	U	A cotton pad is applied to the left hand vertical face of the left hand top ladder, over the position of the sporadic flame noted at 47:00.
64:37	U	The cotton pad is removed (no failure).
66:01	U	A reduced sized cotton pad is applied to the left hand vertical face of the left hand top ladder.
66:31	U	The cotton pad is removed (no failure).
72:00	E	Further collapse of the supporting construction is apparent and flaming is apparent in the region of the specimen.
75:00	U	The outer sheath of the cables on the top ladders and mid tray are softening and are partially detached.
78:56	U	A reduced sized cotton pad is applied to the left hand vertical face of the left hand top ladder.
79:26	U	The cotton pad is removed (no failure).
89:24	U	A cotton pad is applied to the wall over the interface with the pillows and a visible gap between the pillows, above the right hand top ladder.
89:54	U	The cotton pad is removed (no failure).
92:00	U	A reduced sized cotton pad is applied to the left hand vertical face of the left hand top ladder.
92:30	U	The cotton pad is removed (no failure).
99:00	U	Smoke/steam issuing generally has increased in density.
101:00	U	Glowing is apparent at the inside edge of the left hand upstand of the bottom tray.
111:40	U	A reduced sized cotton pad is applied to the top of the left hand vertical face of the left hand top ladder.
112:10	U	The cotton pad is removed (no failure).
113:45	U	A cotton pad is applied to the top of the left hand vertical face of the left hand top ladder.
114:15	U	The cotton pad is removed (no failure).
114:54	U	A cotton pad is applied to the top left hand corner of the specimen at the interface of the wall and pillows.
115:24	U	The cotton pad is removed (no failure).
116:40	U	A cotton pad is applied to the top left hand corner of the specimen at the interface of the wall and pillows.
117:10	U	The cotton pad is removed (no failure).
119:24	U	A cotton pad is applied to the top left hand corner of the specimen at the interface of the wall and pillows.
119:54	U	The cotton pad is removed (no failure).
121:00	U	A cotton pad is applied to the interface between the wall and the pillows above the right hand top ladder.
121:30	U	The cotton pad is removed (no failure).
122:23	U	A reduced size cotton pad is applied to the top of the left hand vertical face of the left hand top ladder.
122:53	U	The cotton pad is removed (no failure).
124:00	E	Flaming in the region of the specimen has decreased.
127:00	U	Glowing is apparent at various positions adjacent to and above the top ladders.

130:00	U	A cotton pad is applied to the top left hand corner of the specimen at the interface of the wall and pillows.
130:30	U	The cotton pad is removed (no failure).
131:11	U	Flaming commences adjacent to the left hand cables of the top left ladder.
131:21	U	INTEGRITY FAILURE OF SPECIMEN C is deemed to have occurred due to sustained flaming at the position noted at 131:11. The flaming is extinguished.
154:00	U	Flaming recommences and all further re-ignitions are extinguished.
182:23		The test is terminated

4 LIMITATIONS

1. This report details the method of construction, the test conditions and the results obtained when the specific element of construction described herein was tested following the procedure outlined in EN 1363-1, and where appropriate EN 1363-2. Any significant deviation with respect to size, constructional details, loads, stresses, edge or end conditions other than those allowed under the field of direct application in the relevant test method is not covered by this report.
2. Because of the nature of fire resistance testing and the consequent difficulty in quantifying the uncertainty of measurement of fire resistance, it is not possible to provide a stated degree of accuracy of the result.
3. The results relate only to the behaviour of the specimen of the element of construction under the particular conditions of test. They are not intended to be the sole criteria for assessing the potential fire performance of the element in use, nor do they reflect the actual behaviour in fires.

This report is the property of the test sponsor and may not be reproduced or passed to a third party without their prior agreement.

Report prepared by:



E Northrop
Head of Testing



S Wright
Technical Officer

Report checked by:



B Richardson
Chief Technical Officer

Report issued:

6th July 2011

APPENDIX 1 SPECIMEN CONSTRUCTION

The item numbers listed in Appendix 1 Table 1 and shown in the figures in Appendix 1 refer to the components of the specimen construction. Any photo numbers refer to those in Appendix 2.

Please note that unless otherwise indicated the following applies:

- a) All dimensions and materials of construction were verified by the laboratory.
- b) Figures are not to scale.
- c) All dimensions are given in mm.

Appendix 1 Table 1

Item	Component	Information
1	Cable 1 Supplier: Product code: Description: Outer sheath colour: Conductor size (mm ²): No. of cores: Measured size (l x Ø): Nominal size (Ø): Weight (kg/km): Photo(s):	Cleveland Cable Company Ltd YY5X1/5 20No. lengths of a type YY control cable comprising plain annealed flexible copper conductors, polyvinyl chloride (PVC) insulated and sheathed. Grey 1.5 5 1150 x 10 8.1 174 2.1.7, 2.1.9, 2.1.10
2	Cable 2 Supplier: Product code: Description: Outer sheath colour: Conductor size (mm ²): No. of cores: Measured size (l x Ø): Nominal size (Ø): Weight (kg/km): Photo(s):	Cleveland Cable Company Ltd 3185TQ1/5 10No. lengths of flexible mains and control cable comprising tinned annealed flexible copper conductors, ethylene propylene rubber (EPR) insulated and chlorosulphonated polyethylene (CSP) outer sheath. Black 1.5 5 1150 x 10 11.2 to 14.4 174 2.1.7, 2.1.9, 2.1.10

Item	Component	Information
3	Cable 3 Supplier: Product code: Description: Outer sheath colour: Conductor size (mm ²): No. of cores: Measured size (l x Ø): Nominal size (Ø): Weight (kg/km): Photo(s):	Cleveland Cable Company Ltd 6181X95 2No. lengths of single core non-armoured mains cable comprising a plain annealed stranded compacted circular copper conductor, cross-linked polyethylene (XLPE) insulated and PVC outer sheath. Black 95 1 1150 x 18 17.5 986 2.1.7, 2.1.9, 2.1.10
4	Cable 4 Supplier: Product Code: Description: Outer sheath colour: Conductor Size (mm ²): No. of cores: Measured Size (l x Ø): Nominal Size (Ø): Weight (kg/km): Photo(s):	Cleveland Cable Company Ltd 6944X95 2No. lengths of mains cable comprising stranded plain annealed copper conductors, XLPE insulated, PVC bedding, galvanised steel wire armour and PVC outer sheath. Black 95 4 1150 x 44 * 40 5392 2.1.7, 2.1.9, 2.1.10
5	Cable 5 Supplier: Product code: Description: Outer sheath colour: Conductor size (mm ²): No. of cores: Measured size (l x Ø): Nominal size (Ø): Weight (kg/km): Photo(s):	Cleveland Cable Company Ltd 6384TQ95 1No. length of flexible mains cable comprising tinned annealed flexible copper conductors, EPR insulated and CSP outer sheath. Black 95 4 1150 x 52 48.4 to 61.0 5366 2.1.7, 2.1.9, 2.1.10

Item	Component	Information
6	Cable 6 Supplier: Product code: Description: Outer sheath colour: Conductor size (mm ²): No. of cores: Measured size (l x Ø): Nominal size (Ø): Weight (kg/km): Photo(s):	Cleveland Cable Company Ltd 6944X185 2No. lengths of mains cable comprising stranded plain annealed copper conductors, XLPE insulated, PVC bedding, galvanised steel wire armour and PVC outer sheath. Black 185 4 1150 x 57 55 9427 2.1.7, 2.1.9, 2.1.10
7	Cable 7 Supplier: Product code: Description: Outer sheath colour: Conductor size (mm ²): No. of cores: Measured size (l x Ø): Nominal size (Ø): Weight (kg/km): Photo(s):	Cleveland Cable Company Ltd 6384TQ185 1No. length of flexible mains cable comprising tinned annealed flexible copper conductors, EPR insulated and CSP outer sheath. Black 185 4 1150 x 65 64 to 80 9227 2.1.7, 2.1.9, 2.1.10
8	Cable 8 Supplier: Product code: Description: Outer sheath colour: Conductor size (mm ²): No. of cores: Measured size (l x Ø): Nominal size (Ø): Weight (kg/km): Photo(s):	Cleveland Cable Company Ltd 6181X185 2No. lengths of single core non-armoured mains cable comprising a plain annealed stranded compacted circular copper conductor, XLPE insulated and PVC outer sheath. Black 185 1 1150 x 23 23.5 1901 2.1.7, 2.1.9, 2.1.10

Item	Component	Information
9	Cable 9 Supplier: Product code: Description: Outer sheath colour: Measured size (l x Ø): Nominal size (Ø): Weight (kg/km): Photo(s):	Cleveland Cable Company Ltd 13008 70No. lengths of internal telephone cable type CW1308 comprising solid tinned annealed copper conductors, PVC insulated, polyester taped and PVC outer sheath. These were tied in a bundle of 100 * diameter. White 1150 x 9 10.7 147 2.1.7 to 2.1.10
10	Cable 10 Supplier: Product code: Description: Outer sheath colour: Conductor size (mm ²): No. of cores: Measured size (l x Ø): Nominal size (Ø): Weight (kg/km): Photo(s):	Cleveland Cable Company Ltd 6491X95BK 1No. length of wiring cable comprising a stranded plain annealed compacted circular copper conductor and PVC outer sheath. Black 95 1 1150 x 15 15.6 909 2.1.7 to 2.1.10
11	Cable 11 Supplier: Product code: Description: Outer sheath colour: Conductor size (mm ²): No. of cores: Measured size (l x Ø): Nominal size (Ø): Weight (kg/km): Photo(s):	Cleveland Cable Company Ltd 6491X185BK 1No. length of wiring cable comprising a stranded plain annealed compacted circular copper conductor and PVC outer sheath. Black 185 1 1150 x 21 21.3 1818 2.1.7 to 2.1.10

Item	Component	Information
12	Left hand top ladder Manufacturer: Product Code: Description: Size (l x w x h x t): Photo(s):	Metsec Plc LSL 100/0300 HDG/3 A light duty galvanised mild steel ladder tray incorporating 4 rungs positioned at 300 centres. The ladder was positioned symmetrical about the wall, with the inner rungs positioned 60 from each wall face. The ladder was supported 350 from each wall face by the strut assembly. 1150 x 335 x 104 x 1.8 2.1.6, 2.1.7, 2.1.9, 2.1.10
13	Right hand top ladder Manufacturer: Product Code: Description: Size (l x w x h x t): Photo(s):	Metsec Plc LSL 100/0150 HDG/3 A light duty galvanised mild steel ladder tray incorporating 4 rungs positioned at 300 centres. The ladder was positioned symmetrical about the wall, with the inner rungs positioned 60 from each wall face. The ladder was supported 350 from each wall face by the strut assembly. 1150 x 190 x 104 x 1.8 2.1.5, 2.1.7, 2.1.9 – 2.1.10
14	Middle tray Manufacturer: Product Code: Description: Size (l x w x h x t): Photo(s):	Metsec Plc CTSL50/0450PG3 A galvanised mild steel perforated tray supported 350 from each wall face by the strut assembly. The tray was positioned symmetrical about the wall. 1150 x 450 x 52 x 1.6 2.1.5, 2.1.7 to 2.1.10
15	Bottom tray Manufacturer: Description: Size (l x w x h x t): Photo(s):	Cambridge Fire Research A hot rolled mild steel tray supported 350 from each wall face by the strut assembly. The tray was positioned symmetrical about the wall. 1150 x 500 x 60 x 1.5 2.1.7 to 2.1.10

Item	Component	Information
16	Strut assembly Manufacturer: Product codes: Description: Overall sizes (h x w x t): Vertical Metstrut: Horizontal Metstrut: Strut cantilever arms: Photo(s):	Metsec Plc MS4125PG3S11, MS2125PG3S11, MS600A An assembly comprising 4No. slotted Metstrut channels affixed to the wall, 12No. strut cantilever arms and 6 No. slotted Metstrut channels affixed to the cantilever arms to provide support for the trays and ladders. 41 x 41 x 2.7 21 x 41 x 2.7 41 x 41 x 2.7 2.1.1, 2.1.7, 2.1.9, 2.1.10
17	Ballast Supplier: Description: Photo(s):	Cambridge Fire Research Steel ballast weights attached to the underside of the service support at the position of the support 350 mm from the exposed surface of the wall only. 2.1.10
18	Fire pillows Supplier: Product Name: Description: Sub components: Intumescent material: Size: Moisture content: Perlite: Density (kg/m ³) Gypsum: Grade:	Northern Fire Engineering Ltd NFEL FR pillows Flexible fire pillows comprising granular expandable graphite based intumescent materials **, perlite ** and gypsum ** in a 3.5:1:1 ** ratio contained within inner plastic and external heavy duty silicone coated glass cloth ** sealing bags. A selection of various sized pillows are tightly packed within the penetration and around the penetrating services and service supports, using the total quantity of each size noted below. Each pillow was orientated with the long side perpendicular * to the wall, such that an equal * amount of each pillow emerges beyond each side of the wall. Where possible, joints between bags were staggered between layers. ≤ 6 ** ≤ 15 % ** 65 to 75 ** 100 to 120 μm **

Item	Component	Information
18 cont.	Internal bag: Material: Bag thickness: External bag: Material: Mass per area (g/m ²): Cloth size(t): Thread size(t): Pillow sizes: Small: Quantity: Overall weight (g): Overall sizes (l x w x t): Small – Medium: Quantity: Overall weight (g): Overall sizes (l x w x t): Large – Medium: Quantity: Overall weight (g): Overall sizes (l x w x t): Large: Quantity: Overall weight (g): Overall sizes (l x w x t): Photo(s):	Plastic 0.6 Heavy duty silicone coated glass cloth **, stitched with 12 bundle thread ** 374 to 417 § 0.23 to 0.25 § 0.1 35 104 to 117 § 301 to 315 x 58 to 65 x 15 to 17 § 21 234 to 242 § 299 to 310 x 106 to 110 x 20 to 27 § 30 368 to 393 § 310 to 323 x 153 to 157 x 23 to 25 § 28 504 to 513 § 304 to 305 x 207 to 212 x 18 to 22 § 2.1.2 to 2.1.4, 2.1.7 to 2.1.10

Key:

* Nominal value

** Sponsor declared value or detail, not verified by laboratory

§ Range based on 4 samples

Appendix 1 Figure 1 – Elevation viewed from the unexposed side

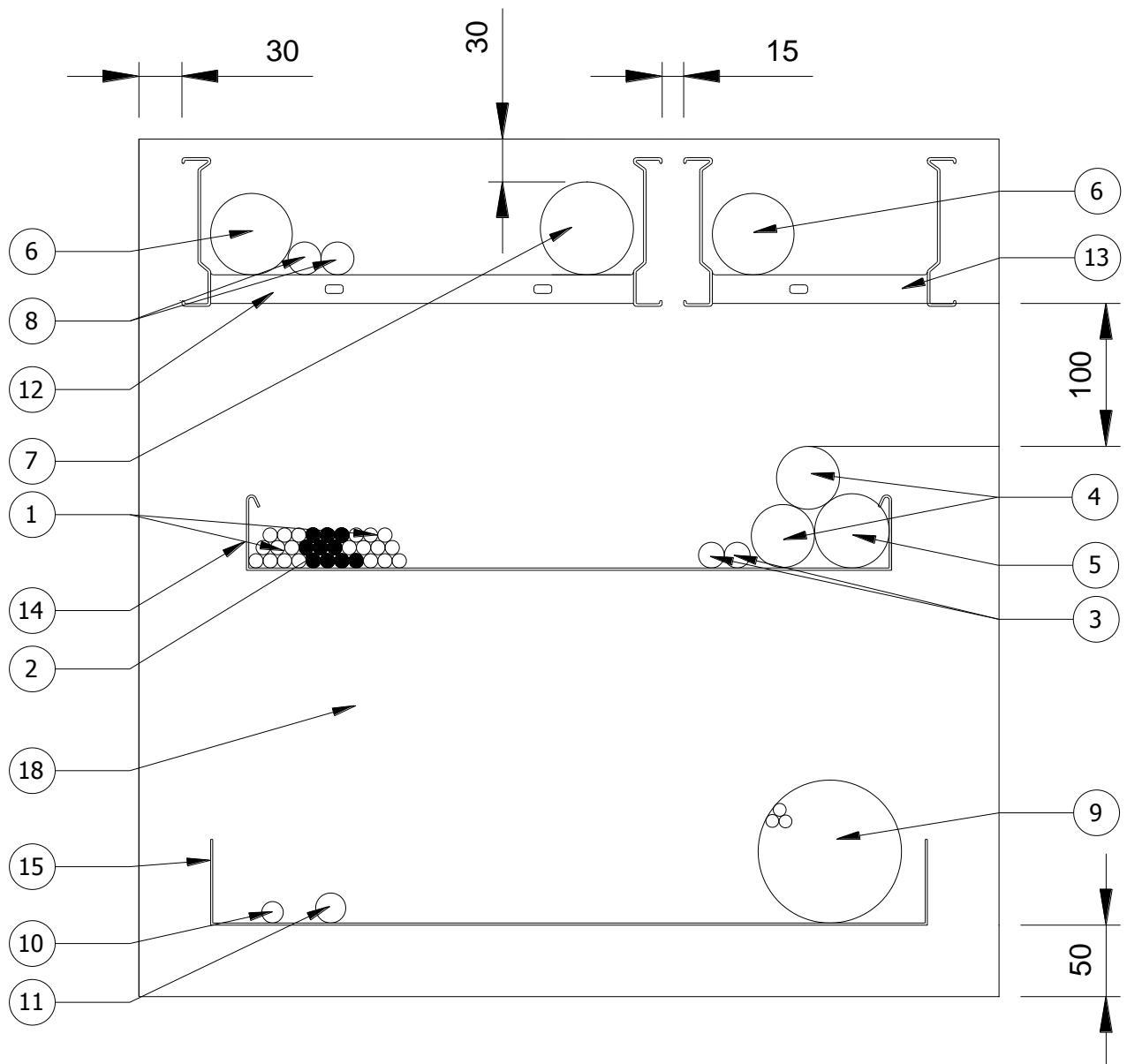

Appendix 1 Figure 2 – Side elevation, excluding services and penetration seal

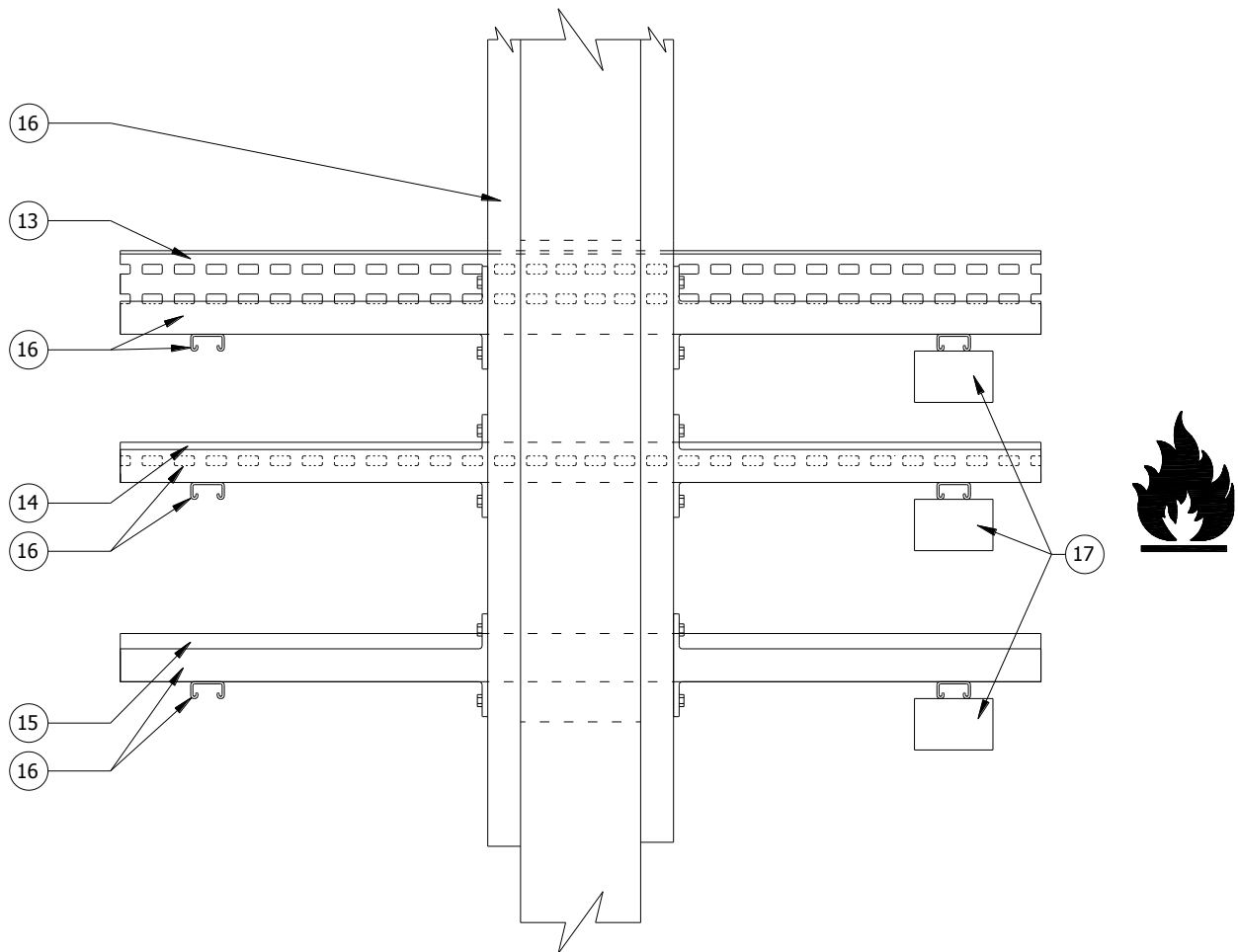

APPENDIX 2 PHOTOGRAPHS

Appendix 2.1 Pre-test photos

Photo 2.1.1



Photo 2.1.2

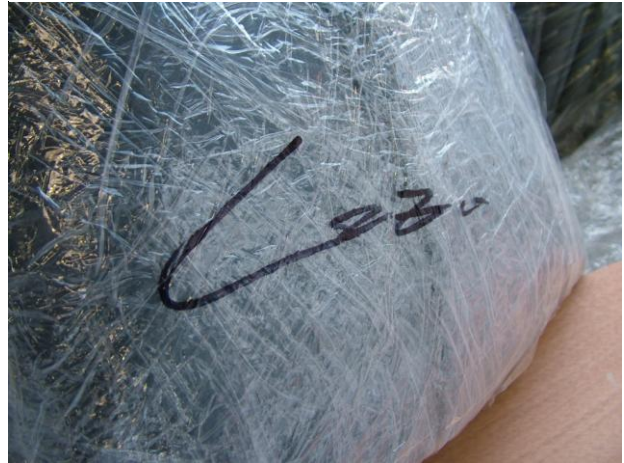

Photo 2.1.3



Photo 2.1.4



Photo 2.1.5



Photo 2.1.6



Photo 2.1.7



Photo 2.1.8



Photo 2.1.9



Photo 2.1.10

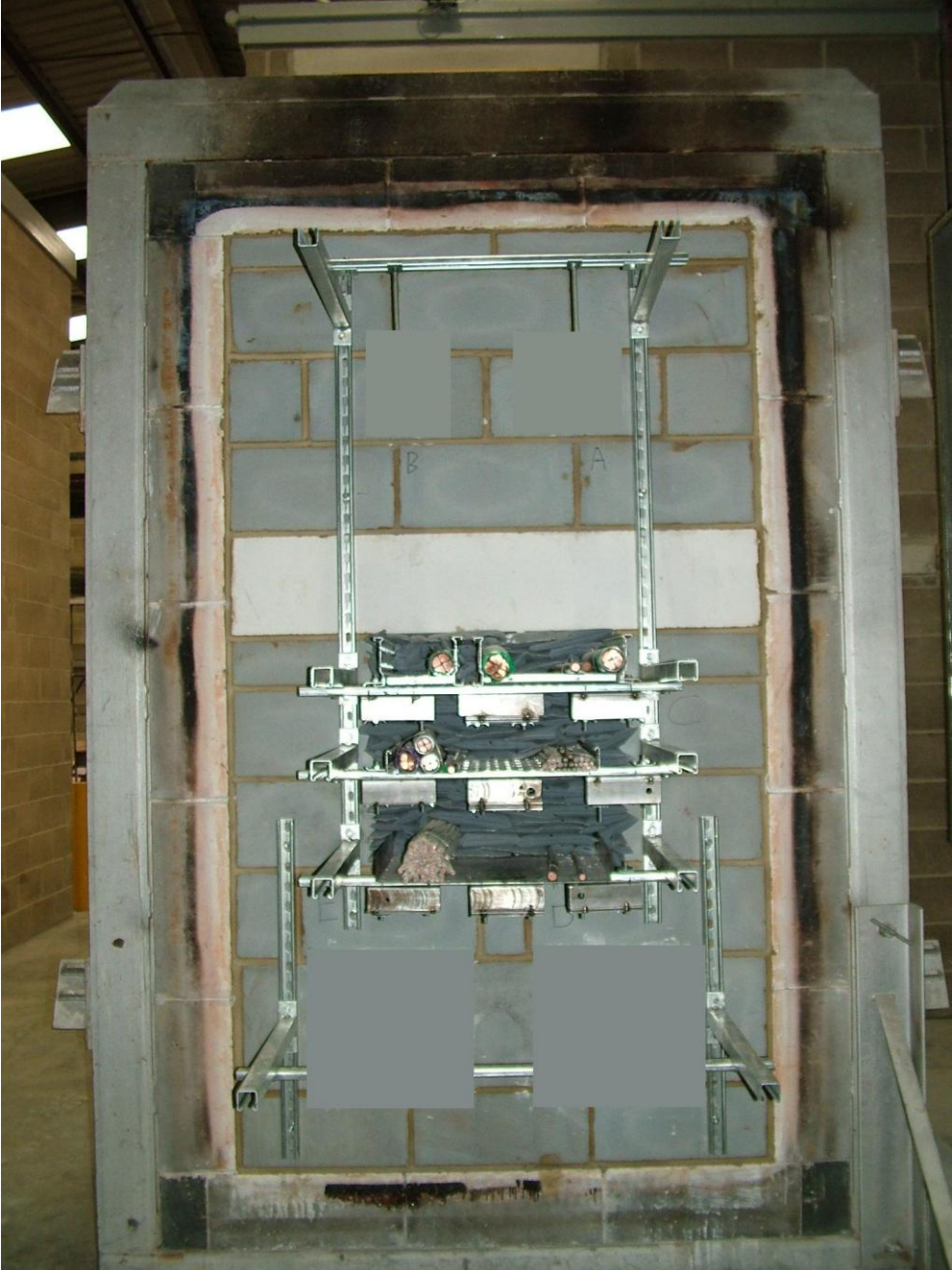

Appendix 2.2 During test photos

Photo 2.2.1



Photo 2.2.2 after 6 minutes



Photo 2.2.3

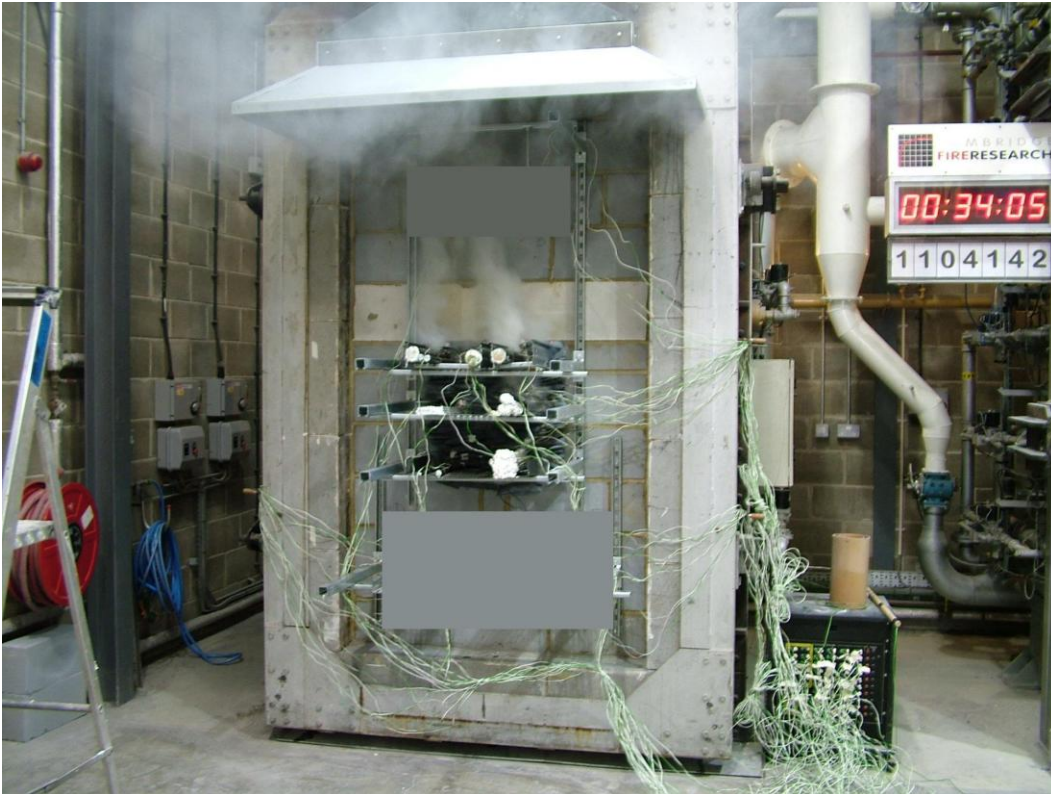

Photo 2.2.4 after 34 minutes



Photo 2.2.5 after 56 minutes

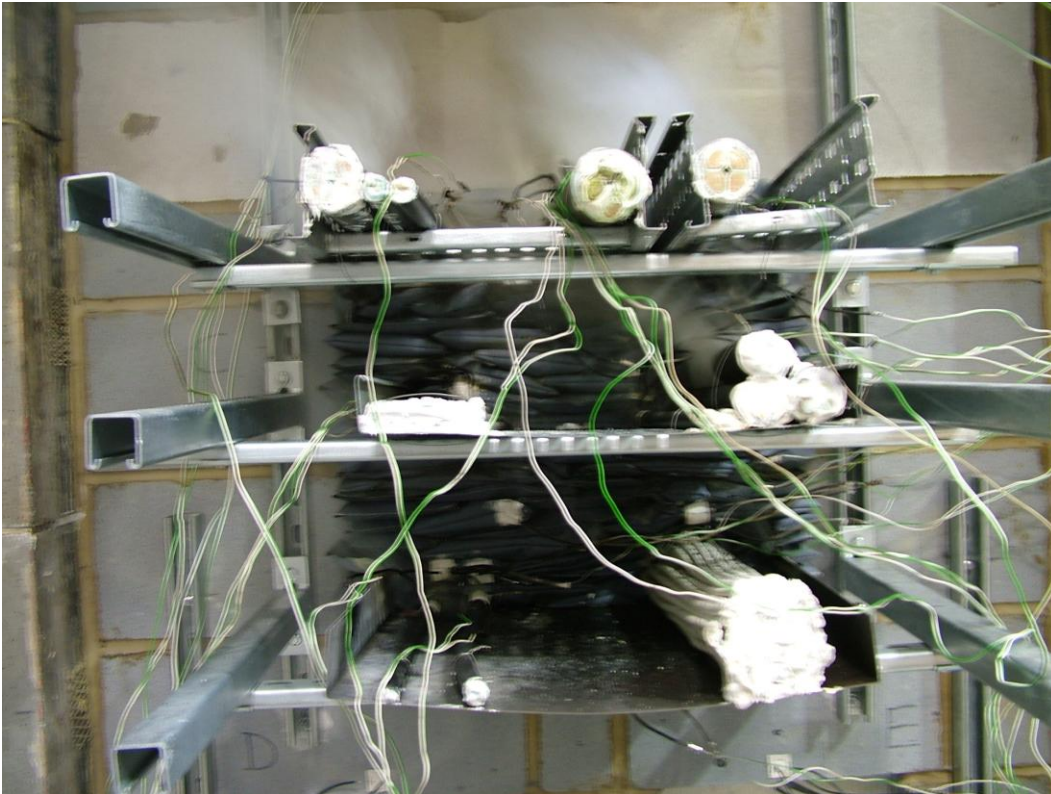

Photo 2.2.6 after 73 minutes



Photo 2.2.7 after 92 minutes

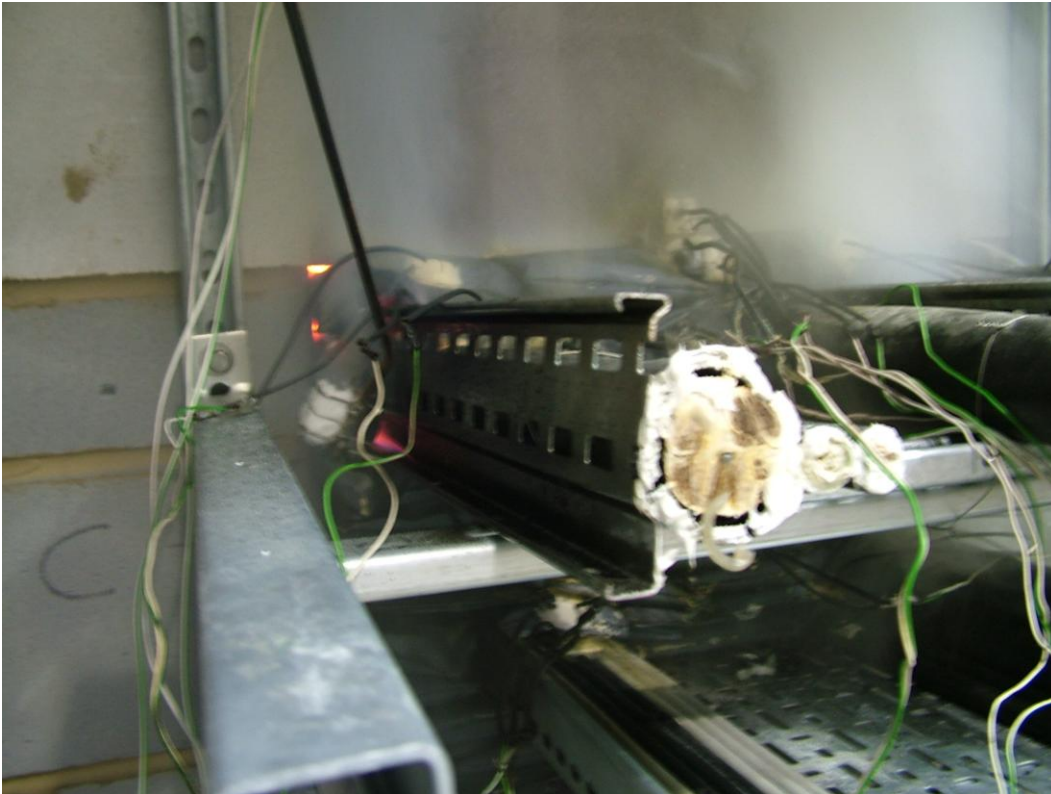

Photo 2.2.8 after 101 minutes

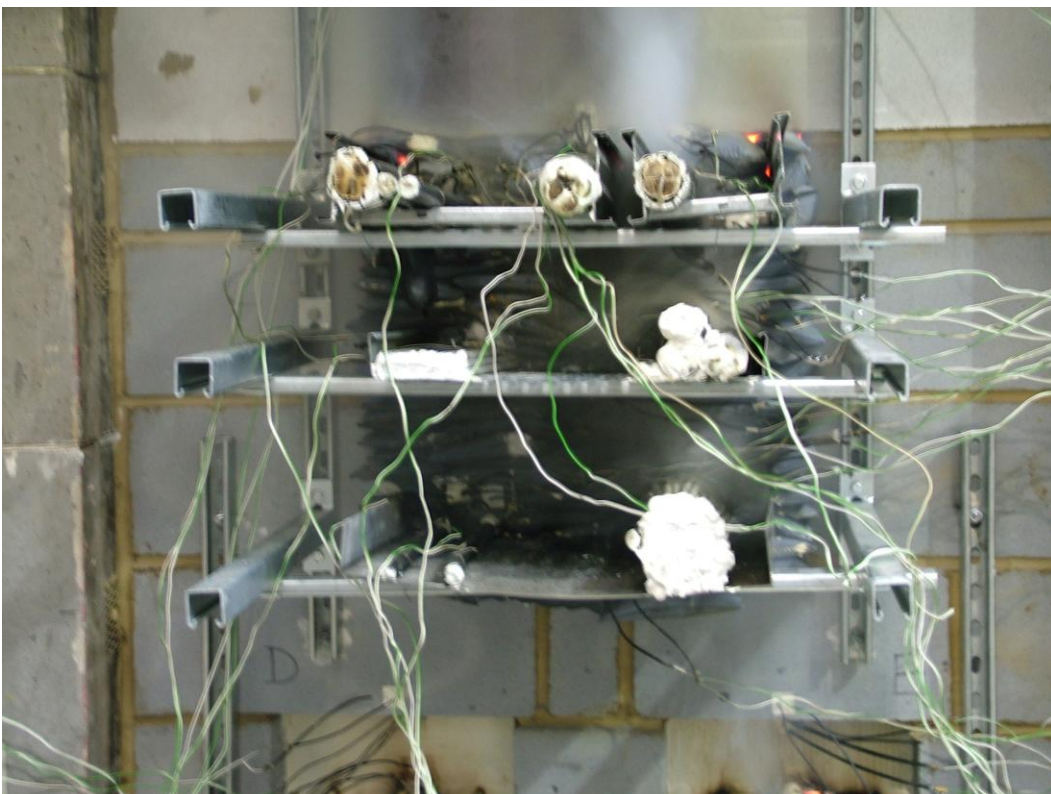
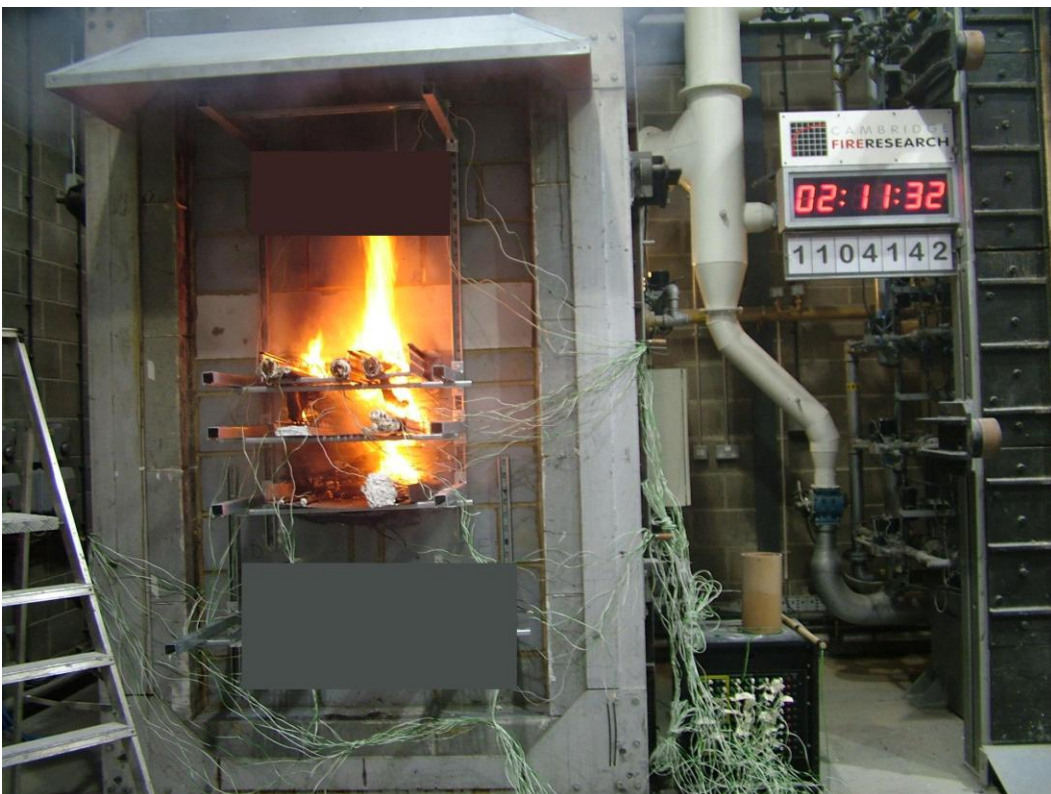

Photo 2.2.9 after 124 minutes



Photo 2.2.10



APPENDIX 3 POSITIONING OF INSTRUMENTATION

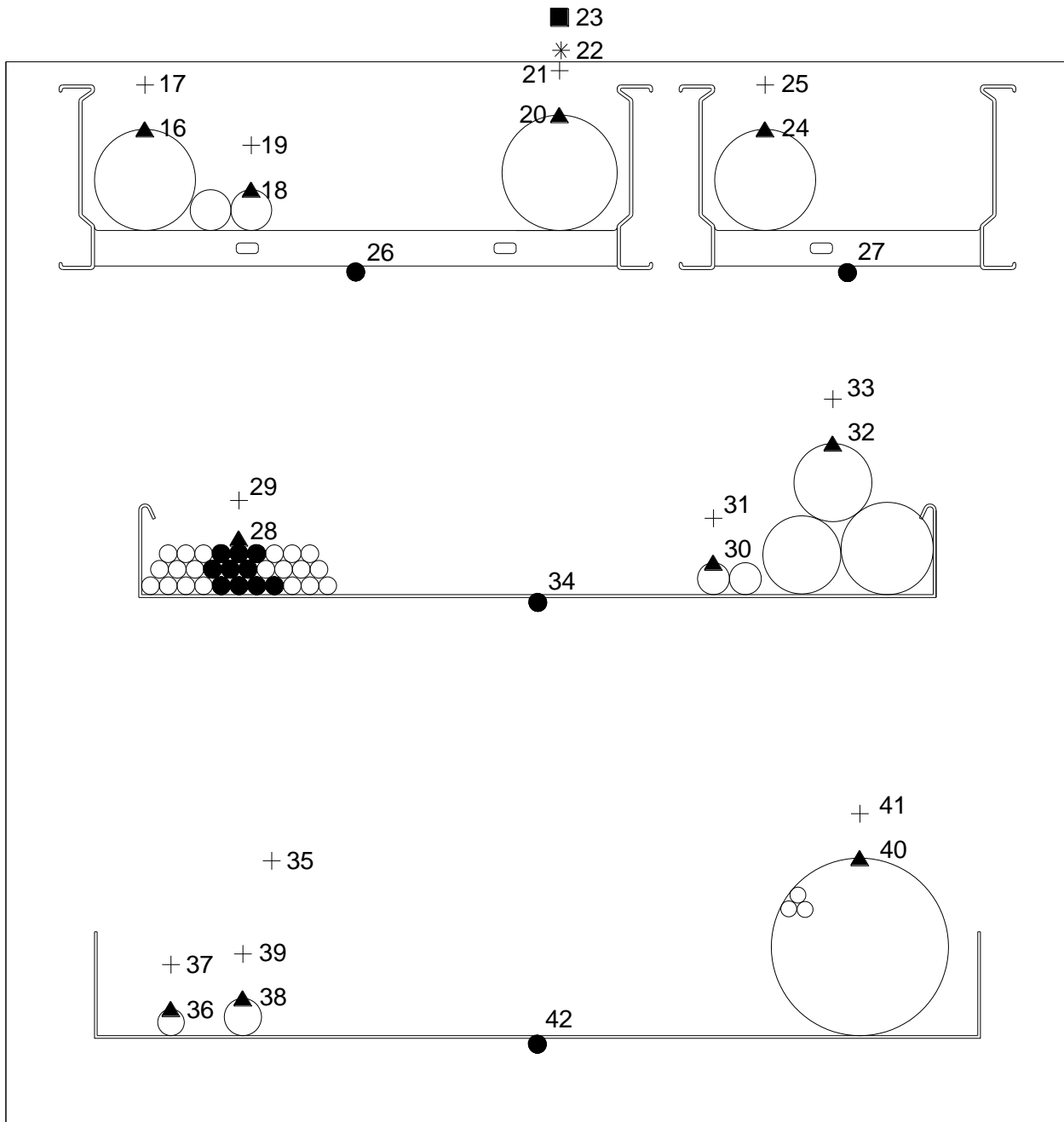

KEY:

- ▲ Position A, on the cables, 25 mm from where they emerge from pillows
- + Position B, on the pillows, 25 mm above the cables
- * Position B, on the pillows, 25 mm from the face of supporting construction
- Position D, on the ladders and trays, 25 mm from where they emerge from pillows
- Position E, on the supporting construction, 25 mm above the top edge of the penetration

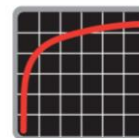

APPENDIX 4 RECORDED THERMOCOUPLE DATA

Time min	Chan 15 °C	Chan 16 °C	Chan 17 °C	Chan 18 °C	Chan 19 °C	Chan 20 °C	Chan 21 °C
0	17	17	17	17	17	17	17
1	16	17	17	17	17	16	18
2	15	21	22	18	20	24	25
3	16	19	20	19	20	20	24
4	16	19	21	20	19	19	22
5	16	22	25	32	29	44	28
6	16	35	32	40	42	48	38
7	16	39	35	39	47	52	45
8	15	39	38	39	49	53	51
9	16	43	42	40	52	56	55
10	16	45	45	43	54	56	61
11	15	45	47	45	54	58	66
12	15	46	48	50	56	60	72
13	16	47	52	55	58	62	78
14	16	52	58	61	60	67	84
15	15	56	66	67	63	66	91
16	15	60	74	74	66	66	96
17	16	67	80	80	68	64	99
18	15	76	83	85	70	65	103
19	16	83	86	90	73	67	105
20	15	89	88	96	75	66	107
21	15	95	91	103	76	68	108
22	15	99	96	109	77	70	109
23	16	101	99	116	79	71	111
24	16	104	100	121	80	75	112
25	16	107	103	126	81	73	112
26	16	110	103	131	82	73	112
27	16	114	102	136	83	75	113
28	16	118	100	141	84	75	113
29	16	122	98	146	85	77	115
30	16	127	98	150	86	78	118
31	16	130	99	154	88	81	119
32	16	134	100	157	89	87	121
33	16	138	102	158	90	89	123
34	16	141	104	158	91	92	124
35	16	144	105	158	92	98	130
36	16	148	100	157	93	100	134
37	16	151	104	156	94	104	137
38	16	155	107	156	95	104	137
39	16	157	110	156	97	105	139
40	15	160	111	157	97	103	142
41	16	164	112	157	99	104	146
42	15	166	114	159	101	104	153
43	16	170	116	160	103	106	159
44	16	172	118	162	105	106	164
45	15	174	119	163	106	106	167
46	15	178	121	164	107	108	125
47	16	181	123	166	107	109	127
48	16	184	125	167	108	110	139
49	16	188	126	168	109	111	147
50	16	191	127	169	109	112	154

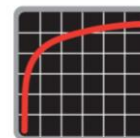

Time min	Chan 15 °C	Chan 16 °C	Chan 17 °C	Chan 18 °C	Chan 19 °C	Chan 20 °C	Chan 21 °C
51	16	195	129	170	109	112	157
52	16	197	130	172	109	113	158
53	16	201	132	173	110	114	160
54	16	204	134	173	111	115	159
55	16	207	135	174	112	116	154
56	16	210	136	174	112	118	149
57	16	213	138	175	112	119	147
58	16	217	139	177	112	120	145
59	16	220	141	180	113	121	144
60	16	225	142	181	113	123	142
61	16	228	143	181	113	125	141
62	16	229	143	181	113	126	140
63	16	235	145	183	114	127	140
64	15	238	146	183	114	128	141
65	16	240	148	184	114	130	142
66	16	242	148	184	114	131	141
67	16	245	149	185	116	132	142
68	16	248	149	187	117	134	142
69	16	251	150	188	117	135	142
70	16	253	151	188	118	135	142
71	16	255	152	188	118	136	143
72	16	256	153	190	119	137	143
73	16	260	154	192	120	138	144
74	16	264	156	194	120	139	143
75	16	265	156	196	120	140	143
76	16	269	158	196	121	141	143
77	16	271	158	198	121	142	143
78	16	274	159	200	123	143	144
79	16	278	160	199	126	145	144
80	16	283	162	201	127	146	144
81	16	286	162	202	129	146	144
82	16	287	162	203	130	147	144
83	16	290	164	204	132	147	143
84	16	291	164	205	133	147	143
85	16	294	164	205	135	147	143
86	16	297	163	207	136	148	145
87	16	300	164	208	137	149	146
88	16	304	165	209	139	150	148
89	16	305	166	211	139	151	148
90	16	309	167	214	139	151	147
91	16	309	169	214	140	151	147
92	16	311	169	215	142	152	149
93	16	311	168	216	143	153	150
94	16	309	167	216	144	154	150
95	16	313	167	217	145	154	151
96	16	314	167	218	144	154	150
97	16	315	168	218	146	154	150
98	16	315	170	219	147	155	151
99	16	318	170	220	149	156	152
100	16	317	169	220	151	157	152



Time	Chan 15	Chan 16	Chan 17	Chan 18	Chan 19	Chan 20	Chan 21
min	°C	°C	°C	°C	°C	°C	°C
101	16	318	169	222	151	157	152
102	16	319	169	222	153	157	153
103	16	322	170	223	153	156	153
104	16	320	173	223	153	156	152
105	16	323	173	225	154	156	152
106	16	327	172	226	153	157	153
107	16	330	173	228	152	156	153
108	16	331	174	226	154	150	154
109	16	332	174	226	157	148	154
110	16	330	176	228	157	147	155
111	16	332	176	231	155	144	154
112	16	331	176	231	156	144	154
113	16	332	175	233	157	141	155
114	16	338	176	233	159	139	157
115	16	341	179	233	161	137	157
116	16	341	180	234	163	136	159
117	16	341	184	237	162	138	160
118	16	339	181	237	164	138	161
119	16	339	180	241	161	135	161
120	16	346	188	244	162	137	161
121	16	342	183	246	162	137	162
122	16	340	181	245	166	137	163
123	16	344	180	248	163	136	165
124	16	345	179	248	163	136	165
125	16	346	182	251	161	137	166
126	16	346	181	251	162	138	167
127	16	343	181	253	163	139	169
128	16	340	183	254	164	139	171
129	16	342	183	255	164	140	171
130	16	345	185	257	164	141	173
131	16	347	123	258	168	142	174
132	16	334	92	316	109	169	222
133	16	332	80	258	93	74	112
134	16	338	82	239	90	72	97
135	16	358	96	250	97	85	92
136	16	379	109	268	104	90	93
137	16	375	134	129	90	83	93
138	16	387	215	180	86	70	93
139	16	397	262	204	84	68	93
140	16	405	292	242	86	66	95
141	16	412	307	252	88	65	95
142	16	418	321	271	91	64	95
143	16	421	332	282	95	67	95
144	16	423	342	289	100	70	96
145	16	432	355	299	107	72	103
146	16	433	366	304	114	73	114
147	16	435	376	308	124	77	130
148	16	436	387	310	138	82	149
149	16	441	396	314	168	105	182
150	16	445	405	319	196	126	209

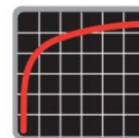

Time	Chan 15	Chan 16	Chan 17	Chan 18	Chan 19	Chan 20	Chan 21
min	°C	°C	°C	°C	°C	°C	°C
151	16	447	411	320	214	137	229
152	16	450	416	323	225	140	245
153	16	453	425	326	234	144	258
154	16	453	432	330	240	147	265
155	16	310	250	269	107	127	282
156	16	360	202	165	101	95	281
157	16	404	226	221	114	98	282
158	16	421	284	274	133	116	283
159	16	434	345	295	155	134	284
160	16	443	378	307	192	140	286
161	16	447	399	317	216	144	288
162	16	451	414	326	231	148	292
163	16	455	425	330	243	149	295
164	16	458	433	333	251	151	298
165	16	459	439	337	257	156	300
166	16	460	446	340	262	160	304
167	16	460	450	342	266	157	307
168	16	464	453	344	270	159	310
169	16	463	456	345	272	161	312
170	16	361	460	347	276	162	313
171	16	341	464	348	278	162	314
172	16	347	467	349	281	162	317
173	16	339	469	352	284	163	319
174	16	338	472	353	288	166	322
175	16	338	473	353	292	166	326
176	17	345	474	355	295	170	327
177	16	344	475	355	296	164	329
178	16	342	475	354	298	164	330
179	16	351	475	354	300	166	331
180	16	357	478	353	301	167	336
181	16	345	480	356	305	172	341
182	16	346	479	358	307	175	345

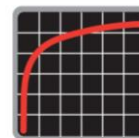

Time min	Chan 22 °C	Chan 23 °C	Chan 24 °C	Chan 25 °C	Chan 26 °C	Chan 27 °C	Chan 28 °C
0	17	17	17	17	17	17	17
1	16	16	16	17	21	17	15
2	19	17	19	20	30	21	15
3	20	16	17	19	30	22	15
4	20	16	17	19	28	22	16
5	22	17	29	24	41	30	16
6	30	19	31	31	55	41	18
7	34	21	32	35	69	49	18
8	36	21	32	40	79	55	19
9	37	23	35	44	85	61	20
10	40	23	36	48	89	67	22
11	42	24	38	52	91	72	23
12	45	26	39	57	93	79	25
13	51	27	41	61	95	85	28
14	59	28	42	67	96	88	31
15	68	32	44	76	95	90	34
16	82	32	46	76	94	92	36
17	87	36	48	80	91	92	38
18	88	36	48	83	89	92	40
19	90	37	50	85	86	93	42
20	90	38	52	88	84	94	43
21	90	40	54	88	83	93	46
22	91	40	57	88	82	93	48
23	92	41	60	89	82	94	50
24	93	43	62	88	82	95	52
25	92	44	64	89	81	96	54
26	92	45	68	89	82	97	57
27	92	44	72	88	82	99	59
28	93	46	76	89	83	99	62
29	93	45	79	89	82	100	64
30	93	47	83	90	82	101	66
31	93	49	86	90	82	100	68
32	93	50	91	90	82	100	70
33	93	52	94	92	81	101	71
34	93	53	97	91	83	101	74
35	93	53	100	90	83	103	76
36	93	51	103	90	84	104	77
37	93	54	109	91	85	104	78
38	93	55	114	91	86	105	80
39	93	54	119	91	87	106	82
40	92	55	124	93	88	108	83
41	93	54	130	94	90	109	84
42	93	56	133	94	92	111	86
43	94	56	137	94	93	112	87
44	94	60	141	94	94	110	88
45	94	59	144	93	94	109	89
46	95	60	148	94	93	109	90
47	95	61	152	94	93	110	91
48	94	61	155	97	94	110	91
49	93	59	158	97	95	113	92
50	93	60	162	97	95	112	92

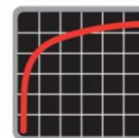

Time	Chan 22	Chan 23	Chan 24	Chan 25	Chan 26	Chan 27	Chan 28
min	°C	°C	°C	°C	°C	°C	°C
51	93	62	165	96	96	112	92
52	92	62	169	97	96	112	93
53	92	62	172	97	97	113	93
54	92	63	173	96	98	112	95
55	93	65	176	96	99	114	95
56	93	64	177	95	100	114	96
57	93	65	180	95	101	115	96
58	93	65	182	94	102	116	97
59	94	66	185	95	102	116	98
60	94	67	187	96	104	117	99
61	94	66	190	98	105	118	99
62	95	69	192	98	106	119	100
63	95	69	193	98	107	118	101
64	96	71	195	98	108	119	102
65	97	72	197	100	109	120	77
66	97	71	200	100	109	122	80
67	99	73	201	100	110	122	104
68	100	73	204	100	111	124	109
69	101	73	206	100	112	125	108
70	102	74	207	101	113	127	111
71	104	75	208	102	114	127	113
72	105	76	210	103	115	127	115
73	107	77	212	103	115	126	116
74	108	78	213	103	116	126	117
75	108	78	217	105	116	129	119
76	110	78	217	104	118	130	119
77	111	79	218	104	119	130	120
78	113	80	220	103	120	131	121
79	115	81	223	103	121	130	122
80	116	83	225	105	122	128	124
81	117	82	226	106	123	128	125
82	118	83	228	107	124	128	126
83	120	84	231	109	125	128	127
84	122	85	232	108	126	129	129
85	124	86	233	108	127	129	130
86	126	87	234	107	127	130	132
87	127	86	235	107	128	131	133
88	129	87	237	109	128	131	134
89	130	88	240	111	129	132	135
90	129	84	243	115	129	134	136
91	131	86	243	114	131	135	138
92	134	90	243	112	133	134	139
93	136	91	245	113	134	133	140
94	137	92	248	116	134	132	141
95	137	91	249	120	135	132	141
96	138	91	251	126	136	136	142
97	139	91	252	128	137	135	143
98	141	93	254	130	138	136	144
99	144	95	255	130	139	135	146
100	145	95	258	132	140	135	147

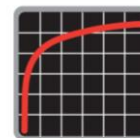

Time	Chan 22	Chan 23	Chan 24	Chan 25	Chan 26	Chan 27	Chan 28
min	°C	°C	°C	°C	°C	°C	°C
101	146	96	260	133	140	135	147
102	148	97	263	132	140	136	148
103	148	97	266	134	139	136	149
104	150	98	268	136	140	137	150
105	150	98	270	139	141	138	150
106	152	99	271	139	140	138	151
107	153	101	272	139	140	139	152
108	153	100	272	138	140	139	154
109	154	100	272	137	141	139	155
110	156	103	274	138	142	141	156
111	157	103	279	141	142	140	157
112	158	104	279	143	142	142	158
113	159	105	278	143	143	144	159
114	160	107	278	142	143	144	160
115	161	107	278	140	143	143	161
116	162	107	278	140	143	144	163
117	163	108	279	141	143	144	164
118	163	107	279	141	144	144	165
119	163	107	282	145	144	147	165
120	164	108	282	145	145	144	166
121	165	109	282	145	145	144	167
122	167	112	282	145	146	143	167
123	167	112	283	147	145	142	168
124	167	111	283	147	145	141	168
125	169	113	285	151	145	141	169
126	170	114	284	150	145	141	170
127	169	113	284	152	145	141	170
128	170	114	285	154	146	141	171
129	171	115	287	156	148	143	172
130	173	117	287	155	149	143	173
131	175	119	287	154	150	144	174
132	182	135	319	133	193	98	154
133	101	81	273	96	140	107	103
134	97	80	276	88	121	125	99
135	92	75	270	86	121	134	103
136	103	83	284	93	131	144	114
137	102	84	117	97	92	101	122
138	104	82	117	97	75	77	113
139	103	81	117	96	75	72	114
140	104	81	121	96	81	85	121
141	106	80	105	95	73	78	113
142	108	80	113	95	78	87	121
143	111	79	116	97	83	103	132
144	115	78	161	97	91	123	143
145	134	78	241	99	99	141	153
146	150	78	275	101	103	151	161
147	163	80	291	108	108	157	167
148	173	83	300	128	127	158	171
149	183	88	306	172	146	159	174
150	194	103	312	211	156	162	177

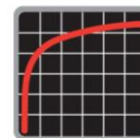

Time min	Chan 22 °C	Chan 23 °C	Chan 24 °C	Chan 25 °C	Chan 26 °C	Chan 27 °C	Chan 28 °C
151	205	118	316	233	162	164	179
152	215	128	318	247	166	166	181
153	224	141	321	260	170	168	183
154	233	148	321	270	174	167	185
155	242	157	333	299	129	172	164
156	249	158	330	295	135	172	166
157	255	164	328	297	149	171	173
158	260	168	327	299	158	169	180
159	265	172	326	301	165	168	185
160	269	177	328	304	169	167	188
161	273	182	329	307	173	168	190
162	277	185	333	312	177	169	192
163	280	190	337	317	180	171	193
164	283	192	343	323	183	173	194
165	287	201	347	327	186	171	196
166	291	210	351	329	188	169	196
167	294	207	354	333	189	171	199
168	296	212	360	337	189	170	199
169	300	216	366	340	191	170	200
170	302	219	368	344	192	171	201
171	304	218	374	351	192	172	202
172	307	222	383	357	192	173	204
173	310	225	384	362	193	174	205
174	313	228	388	368	193	175	206
175	316	233	392	371	195	178	206
176	319	236	391	374	196	178	207
177	322	244	396	377	200	178	207
178	325	246	399	377	196	177	206
179	327	248	403	381	197	179	207
180	330	255	411	388	198	182	206
181	334	260	411	389	200	184	206
182	337	264	413	389	203	185	207

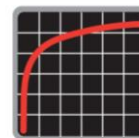

Time min	Chan 29 °C	Chan 30 °C	Chan 31 °C	Chan 32 °C	Chan 33 °C	Chan 34 °C	Chan 35 °C
0	17	17	17	17	17	17	17
1	16	17	16	16	16	16	16
2	16	22	19	18	17	18	16
3	16	20	18	17	17	18	16
4	16	19	17	17	16	18	16
5	22	38	23	20	19	21	18
6	28	43	30	26	28	27	22
7	30	45	34	29	34	31	23
8	31	45	37	31	35	34	24
9	33	47	39	34	38	35	24
10	37	50	41	37	37	37	25
11	37	52	41	40	39	38	25
12	38	55	43	43	42	40	25
13	40	61	44	45	42	41	26
14	40	66	45	47	42	41	26
15	42	71	45	48	40	40	26
16	43	76	47	49	41	40	26
17	43	80	48	50	42	41	26
18	44	84	49	52	41	41	25
19	44	87	50	53	42	41	27
20	45	89	52	55	43	42	26
21	45	90	52	56	42	41	27
22	46	92	53	58	43	41	27
23	48	95	55	60	43	42	28
24	48	98	56	62	44	42	28
25	50	102	57	65	45	44	28
26	51	105	58	67	47	45	28
27	52	108	59	69	47	46	29
28	53	110	60	72	48	46	30
29	55	113	62	74	49	46	30
30	56	115	62	76	51	47	31
31	58	117	63	79	52	47	31
32	60	119	64	81	53	48	32
33	62	121	65	84	56	49	32
34	65	122	67	87	57	49	33
35	67	124	68	91	58	50	33
36	68	125	69	93	59	51	32
37	69	127	69	94	60	51	34
38	71	129	70	96	59	51	34
39	72	130	72	98	59	52	35
40	73	131	72	100	60	54	36
41	74	132	73	104	63	57	37
42	76	134	73	107	63	58	39
43	77	135	74	110	63	59	42
44	79	136	75	112	63	59	44
45	80	137	76	115	64	59	47
46	81	138	78	117	66	59	51
47	82	139	78	120	69	61	53
48	83	140	78	123	72	61	53
49	83	142	78	126	76	63	53
50	84	143	77	128	76	65	54

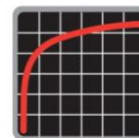

Time min	Chan 29 °C	Chan 30 °C	Chan 31 °C	Chan 32 °C	Chan 33 °C	Chan 34 °C	Chan 35 °C
51	84	144	78	130	73	65	57
52	85	146	78	132	74	68	54
53	86	147	79	135	74	69	57
54	86	148	80	136	73	69	57
55	87	148	80	138	73	68	57
56	87	149	81	141	74	68	61
57	88	150	83	143	76	69	62
58	88	151	84	144	75	69	64
59	89	152	85	147	75	64	64
60	90	153	87	150	76	67	67
61	91	155	88	153	79	71	66
62	91	156	88	155	80	72	67
63	92	157	91	157	79	73	68
64	93	158	92	159	80	74	69
65	94	159	94	161	82	75	69
66	95	160	95	162	82	75	69
67	95	161	97	164	83	76	71
68	96	162	96	166	84	74	73
69	96	163	96	167	85	75	74
70	96	164	96	168	86	77	75
71	97	165	98	168	87	76	71
72	97	166	99	168	89	76	74
73	98	167	100	168	88	77	67
74	98	168	100	169	87	77	77
75	98	169	100	169	89	79	72
76	98	170	100	170	89	80	70
77	98	169	101	171	89	79	78
78	98	170	102	173	89	79	79
79	98	171	104	173	88	79	77
80	98	172	105	175	88	80	77
81	98	172	105	175	88	81	77
82	99	172	106	176	88	82	77
83	98	173	107	177	88	82	78
84	99	174	109	178	87	82	78
85	99	176	110	180	88	83	79
86	98	178	110	181	87	83	77
87	98	178	110	182	86	82	76
88	99	180	111	184	88	85	81
89	99	180	112	185	89	86	80
90	98	179	111	185	91	87	75
91	99	177	111	186	89	87	76
92	99	177	114	187	88	88	79
93	99	178	116	189	88	89	74
94	98	180	116	190	88	91	79
95	98	181	117	191	89	92	73
96	98	181	115	192	90	92	74
97	98	181	117	192	89	91	81
98	99	181	118	192	89	93	82
99	98	183	118	191	89	94	80
100	98	182	121	192	89	95	80

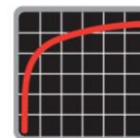

Time	Chan 29	Chan 30	Chan 31	Chan 32	Chan 33	Chan 34	Chan 35
min	°C	°C	°C	°C	°C	°C	°C
101	98	184	122	192	89	97	79
102	98	183	123	191	88	96	83
103	98	182	126	191	88	96	81
104	98	181	126	192	88	96	81
105	98	184	126	194	89	98	80
106	98	185	127	195	89	99	79
107	98	184	127	194	89	98	80
108	98	184	128	194	90	96	80
109	98	183	129	193	89	94	80
110	98	184	131	193	89	96	81
111	98	186	132	196	90	99	79
112	99	187	132	197	91	101	79
113	98	188	133	199	91	102	79
114	98	188	134	199	91	101	80
115	99	186	135	200	90	98	80
116	99	186	138	201	91	97	81
117	99	186	139	203	91	97	81
118	99	187	141	206	90	96	82
119	99	187	142	208	93	99	79
120	99	190	144	211	91	102	78
121	99	190	146	213	92	103	76
122	100	191	148	214	92	101	78
123	100	192	149	216	94	104	76
124	100	192	150	219	94	103	76
125	101	192	152	222	97	105	75
126	101	192	152	223	96	105	76
127	101	192	152	226	97	107	74
128	102	192	153	228	98	107	73
129	102	192	153	231	98	109	76
130	103	192	155	234	99	109	75
131	104	192	158	236	99	108	77
132	106	133	226	280	120	87	68
133	94	101	97	673	102	65	61
134	91	99	91	445	95	59	60
135	90	117	92	678	95	61	61
136	91	152	93	630	97	61	61
137	91	128	91	105	97	62	62
138	92	108	87	103	91	57	63
139	91	111	83	100	90	57	64
140	91	104	81	-34	90	53	63
141	92	102	79	102	92	58	63
142	92	107	80	99	93	55	62
143	92	114	82	104	94	55	64
144	92	133	85	118	94	59	63
145	93	152	86	150	100	65	63
146	94	164	87	187	101	68	63
147	95	175	90	214	101	70	62
148	96	183	92	231	102	71	61
149	97	189	94	242	102	72	61
150	98	194	96	249	105	74	61

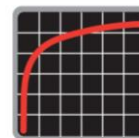

Time	Chan 29	Chan 30	Chan 31	Chan 32	Chan 33	Chan 34	Chan 35
min	°C	°C	°C	°C	°C	°C	°C
151	100	198	100	254	107	75	61
152	101	202	103	258	112	76	62
153	105	206	106	261	118	78	62
154	108	208	114	263	124	79	62
155	111	132	114	142	124	69	64
156	114	133	100	199	109	58	62
157	119	153	99	223	105	61	62
158	126	174	101	243	110	67	62
159	131	184	105	256	119	72	62
160	134	191	112	262	127	75	61
161	137	196	118	267	134	78	61
162	139	201	126	271	142	79	61
163	141	206	134	274	150	81	62
164	143	211	142	276	157	82	63
165	143	216	151	280	162	84	63
166	144	218	161	287	167	87	64
167	146	221	168	292	169	86	65
168	147	223	174	295	172	91	65
169	148	224	179	293	176	98	65
170	149	225	183	282	179	107	65
171	149	226	187	272	181	112	65
172	150	228	191	260	184	115	66
173	152	229	194	241	186	116	67
174	154	231	196	233	189	117	68
175	154	233	197	240	197	121	70
176	156	234	202	235	197	122	70
177	156	235	200	241	201	123	72
178	155	195	121	215	196	85	72
179	156	203	129	217	201	98	71
180	157	211	146	229	210	110	70
181	159	218	162	236	217	117	70
182	161	218	177	234	220	124	69

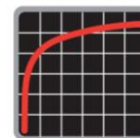

Time min	Chan 36 °C	Chan 37 °C	Chan 38 °C	Chan 39 °C	Chan 40 °C	Chan 41 °C	Chan 42 °C
0	17	17	17	17	17	17	17
1	16	16	16	15	16	16	15
2	15	16	16	16	16	16	16
3	15	16	16	16	16	16	16
4	13	16	18	16	16	16	16
5	27	19	23	18	21	18	18
6	22	22	30	21	23	24	22
7	10	22	33	22	25	28	25
8	0	22	38	23	27	30	27
9	-11	23	45	24	29	33	29
10	-19	25	53	25	31	34	32
11	-30	25	60	26	33	36	33
12	69	27	69	29	35	39	34
13	78	27	78	30	37	39	35
14	85	30	86	31	39	40	36
15	92	32	93	31	41	40	36
16	97	34	100	33	43	40	38
17	102	36	107	34	46	40	38
18	109	36	114	35	49	41	39
19	114	38	121	38	52	41	40
20	117	40	127	38	54	42	41
21	122	40	132	39	57	43	43
22	125	40	137	41	59	44	44
23	129	41	141	41	67	46	46
24	132	41	145	42	71	48	47
25	134	42	148	43	73	53	49
26	137	43	151	43	77	55	50
27	139	45	154	45	83	55	51
28	141	46	156	47	85	56	52
29	144	46	157	48	86	58	53
30	144	47	158	49	87	62	55
31	147	47	159	50	87	63	55
32	148	47	161	51	88	64	57
33	150	49	162	51	91	69	57
34	151	50	163	53	91	68	58
35	153	52	164	54	92	69	59
36	153	53	166	54	92	70	59
37	156	53	167	54	92	71	60
38	156	55	167	55	93	69	61
39	157	56	168	57	93	68	62
40	155	57	170	56	94	71	62
41	155	60	171	58	95	74	63
42	155	61	172	61	96	74	64
43	155	63	174	60	99	76	65
44	157	63	173	60	101	76	65
45	159	64	175	60	102	77	66
46	159	65	174	59	105	79	66
47	158	67	173	60	108	82	67
48	158	68	174	62	109	82	68
49	159	69	175	62	111	83	69
50	157	71	175	64	115	86	69



Time	Chan 36	Chan 37	Chan 38	Chan 39	Chan 40	Chan 41	Chan 42
min	°C	°C	°C	°C	°C	°C	°C
51	157	70	174	64	115	88	70
52	158	72	173	65	118	89	71
53	158	75	175	67	121	90	72
54	159	74	175	67	121	90	72
55	158	74	176	68	122	90	73
56	158	75	177	70	122	91	73
57	160	76	177	70	124	92	74
58	160	77	177	72	125	93	75
59	160	78	176	72	126	94	75
60	158	78	177	73	128	96	76
61	157	80	176	73	130	96	77
62	160	82	175	74	130	96	78
63	158	82	175	75	130	97	78
64	158	83	174	76	131	97	79
65	159	85	172	76	132	97	79
66	160	84	172	78	132	97	80
67	160	84	172	80	132	98	81
68	161	85	171	82	132	98	82
69	160	85	171	83	133	98	82
70	160	88	171	85	133	98	82
71	160	88	171	86	133	98	83
72	161	88	171	86	133	98	84
73	162	87	170	87	134	99	84
74	162	88	171	88	134	98	85
75	162	90	171	89	134	98	85
76	163	90	171	90	135	98	86
77	162	89	171	90	134	97	86
78	164	90	171	91	134	97	87
79	164	89	170	89	135	97	88
80	164	89	170	90	136	98	89
81	164	89	170	89	137	98	89
82	165	88	169	89	138	98	89
83	166	86	170	90	138	98	90
84	167	86	169	90	138	97	90
85	169	86	169	89	138	97	91
86	169	86	170	90	138	97	91
87	167	86	171	91	137	96	92
88	169	87	171	90	140	97	93
89	167	87	170	91	142	97	93
90	167	89	170	92	143	98	94
91	167	88	172	93	144	96	95
92	170	87	172	92	144	97	95
93	169	87	171	90	146	97	96
94	170	87	171	90	148	97	96
95	168	89	171	90	152	97	95
96	164	89	170	91	159	98	96
97	166	87	171	92	162	98	97
98	168	88	172	93	164	98	99
99	169	89	171	92	163	98	99
100	171	90	172	92	163	98	100

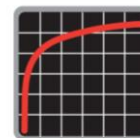

Time	Chan 36	Chan 37	Chan 38	Chan 39	Chan 40	Chan 41	Chan 42
min	°C	°C	°C	°C	°C	°C	°C
101	172	90	171	91	163	98	100
102	174	89	172	91	163	97	101
103	173	89	173	91	164	98	102
104	173	89	173	92	164	97	103
105	175	90	173	91	167	98	104
106	173	90	172	91	168	97	105
107	175	89	174	92	170	97	104
108	177	88	175	92	170	97	105
109	176	88	176	92	171	96	105
110	177	87	175	91	172	96	105
111	177	88	175	90	177	97	105
112	178	89	176	91	179	96	106
113	179	88	177	91	181	97	106
114	178	88	178	92	182	97	107
115	178	88	180	92	182	96	108
116	178	88	180	92	185	97	109
117	173	86	181	92	188	97	110
118	174	85	182	93	189	97	110
119	178	86	181	91	194	99	110
120	179	87	180	91	196	99	110
121	178	88	180	90	197	100	110
122	179	87	181	91	198	101	111
123	179	87	180	90	203	103	111
124	179	86	180	91	204	104	111
125	179	87	181	91	204	107	112
126	180	87	180	90	205	108	112
127	180	88	180	90	205	111	112
128	179	88	180	91	205	113	113
129	183	88	181	92	204	116	113
130	181	90	182	92	204	116	113
131	182	90	184	93	203	117	113
132	66	112	178	102	211	102	93
133	88	88	107	94	95	89	69
134	104	84	125	88	85	83	65
135	126	80	137	83	83	79	63
136	144	81	140	81	83	78	62
137	152	81	139	81	91	78	63
138	157	80	137	82	84	83	61
139	160	79	128	82	84	80	62
140	164	78	128	77	77	77	61
141	167	77	127	76	75	77	59
142	169	78	126	74	74	78	58
143	171	75	124	73	74	75	58
144	172	73	125	71	75	75	58
145	174	74	128	74	78	78	58
146	175	73	133	74	78	79	60
147	177	73	138	73	79	79	65
148	178	73	143	70	81	80	73
149	180	73	148	75	83	80	80
150	180	73	153	81	85	80	88

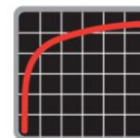

Time	Chan 36	Chan 37	Chan 38	Chan 39	Chan 40	Chan 41	Chan 42
min	°C	°C	°C	°C	°C	°C	°C
151	182	75	157	79	87	81	93
152	181	77	161	83	88	81	97
153	183	78	165	84	91	82	102
154	184	80	168	84	93	82	104
155	182	84	168	85	98	84	79
156	184	83	172	84	97	84	72
157	186	82	175	88	99	81	84
158	187	83	177	90	104	82	96
159	187	85	179	89	109	82	103
160	188	87	180	79	117	84	107
161	188	87	182	89	128	85	110
162	190	88	184	93	141	86	112
163	189	89	186	96	155	89	114
164	189	90	188	97	166	87	115
165	190	91	188	97	177	89	117
166	186	92	189	99	188	89	118
167	187	92	191	102	194	88	119
168	181	92	190	100	200	92	122
169	183	94	192	101	205	89	123
170	187	93	191	101	209	104	122
171	188	94	193	102	211	111	121
172	188	94	194	103	215	116	122
173	187	94	194	105	218	126	123
174	186	94	197	107	220	134	126
175	192	95	198	108	221	146	127
176	194	96	198	109	222	156	129
177	192	96	197	110	223	134	120
178	196	100	190	107	211	122	73
179	198	100	185	107	213	130	66
180	193	100	180	107	217	149	65
181	191	101	179	108	221	169	69
182	187	101	180	108	225	175	85