

HDPE Flap Valves

- DN100-1000

- The Fernco range of Flap Valves are suitable for pipes from DN100 to DN1000
- Co-extrusion seal makes installation quicker and easier with no need for additional tapes or sealants, ensuring optimal performance every time
- HDPE material is reliably strong yet lightweight for installation convenience
- HDPE design for protection against the environment
- Manufactured to class 5 standard of DIN 19569-4 and BS7775
- 316 stainless steel as standard
- Up to 60 year life expectancy with regular inspection and appropriate maintenance



Fernco have a new and improved range of high-quality Flap Valves made from HDPE (High-Density Polyethylene). The Flap Valve acts as a Non-Return Valve for the prevention of backflow associated with drainage systems, rivers and estuaries etc. The lightweight product is easy to install, corrosion resistant and has significant improvements at both low and high heads of pressure.

Flap Valve Standard Range

Wall Mounted	Spigot Mounted	Tidal Wall Mounted	Flange Mounted	Tidal Flange Mounted	Application
FV100	FVS100/FVS110	FVT100	FVF100	FVTF100	DN100 pipe
FV125	FVS110/FVS125	-	FVF125	FVTF125	DN125 pipe
FV150	FVS150/FVS160	FVT150	FVF150	FVTF150	DN150 pipe
FV200	FVS200/FVS225	FVT200	FVF200	FVTF200	DN200 pipe
FV225	FVS225	FVT225	-	-	DN225 pipe
FV250	FVS250/FVS280	FVT250	FVF250	FVTF250	DN250 pipe
FV300	FVS280/FVS300	FVT300	FVF300	FVTF300	DN300 pipe
FV350	FVS350	-	FVF350	FVTF350	DN350 pipe
FV400	FVS400	FVT400	FVF400	FVTF400	DN400 pipe
FV450	FVS450	-	FVF450	FVTF450	DN450 pipe
FV500	FVS500	FVT500	FVF500	FVTF500	DN500 pipe
FV600	FVS600/FVS630	FVT600	FVF600	FVTF600	DN600 pipe
FV700	-	-	-	-	DN700 pipe
FV800	-	-	-	-	DN800 pipe
FV900	-	-	-	-	DN900 pipe
FV1000	-	-	-	-	DN1000 pipe

 Larger sizes available on request



FV150

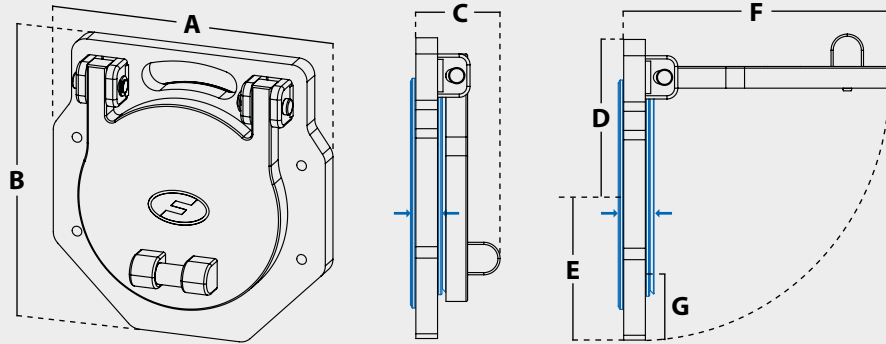

EPDM Co-extrusion seal
(FV150+)

FV100

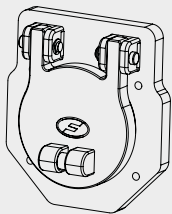

FV450

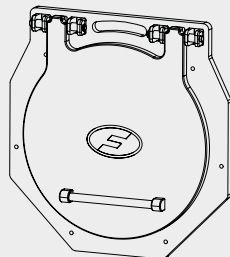

FV600

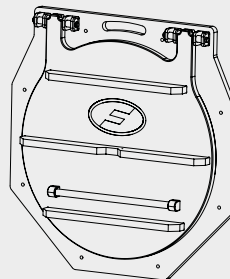

FV700

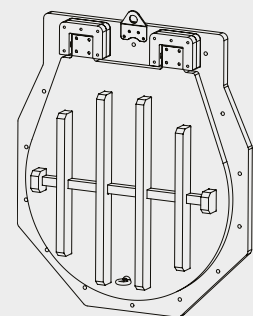

Product Code	DN	A (mm)	B (mm)	C (mm)	D (mm)	E (mm)	F (mm)	G (mm)	Mounting Hole PCD (mm)	Pressure (mwc)	Weight (kg)
FV100	100	212	235	77	129	106	207	56	183	7	1.29
FV125	125	254	268	77	142	127	233	65	225	7	1.68
FV150	150	274	291	79	154	137	248	62	240	7	1.89
FV200	200	341	349	79	179	170	298	71	312	7	2.72
FV225	225	351	367	79	191	176	322	63	315	7	2.96
FV250	250	379	392	79	202	190	346	65	350	7	3.37
FV300	300	429	442	79	228	214	396	65	400	7	4.23
FV350	350	499	517	79	268	249	472	74	460	7	5.69
FV400	400	544	565	79	293	272	522	72	515	7	6.69
FV450	450	594	615	79	318	297	572	72	565	7	7.85
FV500	500	649	667	99*	343	324	622	75	620	7	10.07
FV600	600	754	770	99*	393	377	721	77	725	7	13.55
FV700	700	895	1080**	134	632**	448	961	98	850	7	37.3
FV800	800	995	1180**	134	682**	498	1061	98	950	7	44.2
FV900	900	1095	1280**	134	732**	548	1161	98	1050	7	51.6
FV1000	1000	1195	1380**	134	782**	598	1261	98	1150	7	59.6

*Dimension taken from the back of the wall plate to front plate strengthening ribs.

**These values are taken from the top of the lifting bracket.

Larger sizes available on request

Mounting Sets

Flap Valve	Mounting Holes	Part Code	Description
FV100 - 200	4	FVMS-01	Flap Valve Mounting Set A4 Stainless Steel Bolts and Chemical Anchors 4xM8
FV225 - 300	5	FVMS-02	Flap Valve Mounting Set A4 Stainless Steel Bolts and Chemical Anchors 5xM8
FV350 - 450	6	FVMS-03	Flap Valve Mounting Set A4 Stainless Steel Bolts and Chemical Anchors 6xM8
FV500 - 600	8	FVMS-04	Flap Valve Mounting Set A4 Stainless Steel Bolts and Chemical Anchors 8xM8
FV700 - 1000	14	FVMS-06	Flap Valve Mounting Set A4 Stainless Steel Bolts and Chemical Anchors 14xM12

FVMS-01



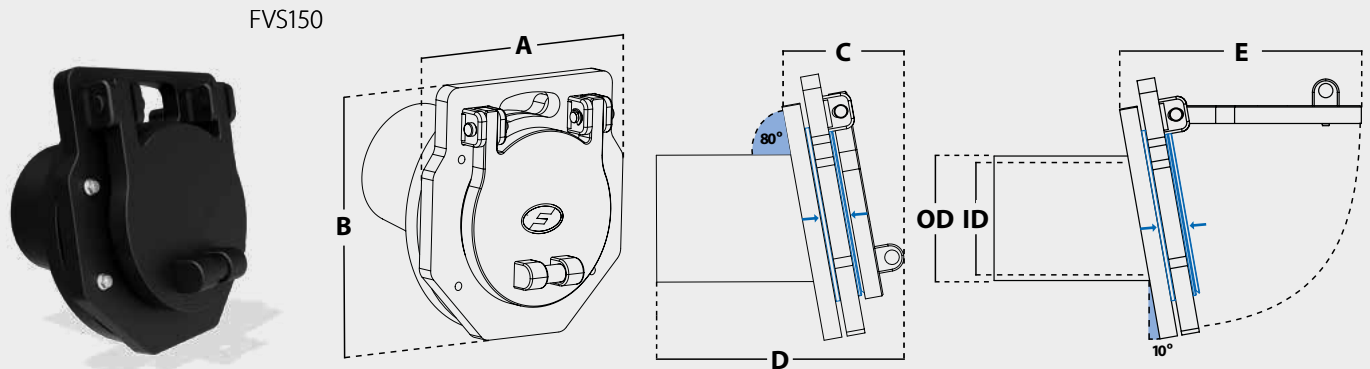

EPDM Co-extrusion seal
(FVS150+)

FVS100

FVS300

FVS450

FVS600

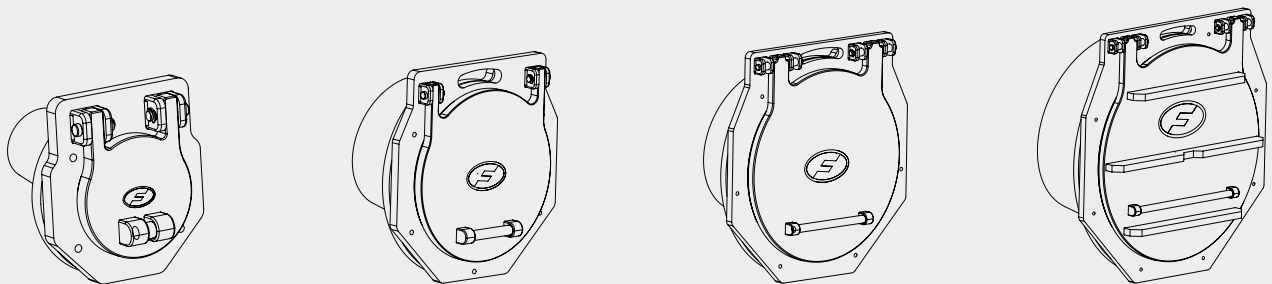

Product Code	DN	Spigot OD (mm)	Spigot ID (mm)	A (mm)	B (mm)	C (mm)	D (mm)	E (mm)	Pressure (mwc)	Weight (kg)
FVS100	100	90	83	212	235	125	264	234	7	2
FVS110	110	110	102	212	235	125	267	234	7	2
FVS125	125	125	115	254	268	130	267	260	7	2.7
FVS150	150	140	123	254	268	130	271	260	7	2.9
FVS160	160	160	148	274	291	135	279	274	7	3.1
FVS200	200	180	159	274	291	135	277	274	7	3.5
FVS225	225	200	184	340	349	144	284	327	7	4.6
FVS250	250	225	211	351	367	146	288	350	7	4.8
FVS280	280	250	235	379	392	150	293	374	7	5.6
FVS300	300	280	263	379	392	151	296	376	7	5.6
FVS350	350	315	300	429	442	157	300	425	7	6.8
FVS400	400	355	333	499	517	167	309	490	7	10.3
FVS450	450	400	375	544	565	173	307	543	7	12.7
FVS500	500	450	422	594	615	178	369	597	7	14.7
FVS525	525	500	469	649	667	195*	378*	648	7	17.8
FVS600	600	560	526	685	698	199*	393*	673	7	20
FVS630	630	630	591	754	770	224*	405*	748	7	25.5

*Dimension taken from end of spigot to front plate strengthening ribs.

Spigot mounted Flap Valves can be connected to a pipe in two ways.

1. By using a Fernco Shear banded coupling to connect the spigot flap valve to the connecting pipe, this method will offer superior stability of the valve. The valve can be sized specific to the connecting pipe's outside diameter and therefore remove the need to seal inside the pipeline and restrict bore.
2. By inserting the spigot inside of the pipe and securing into position using a supplied EPDM sealing tape. For this option simply select the spigot size (column Spigot ID) which will fit inside the pipe.

Please ensure supplied OD and ID measurements are accurate so the correct bush can be specified with the Spigot Flap Valve.



FVT150

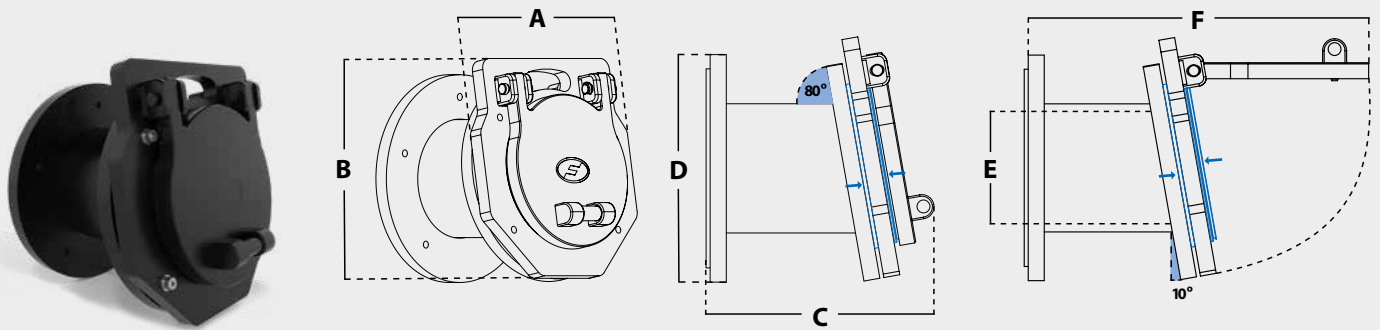

EPDM Co-extrusion seal
(FVT150+)

FVT100

FVT300

FVT500

FVT600

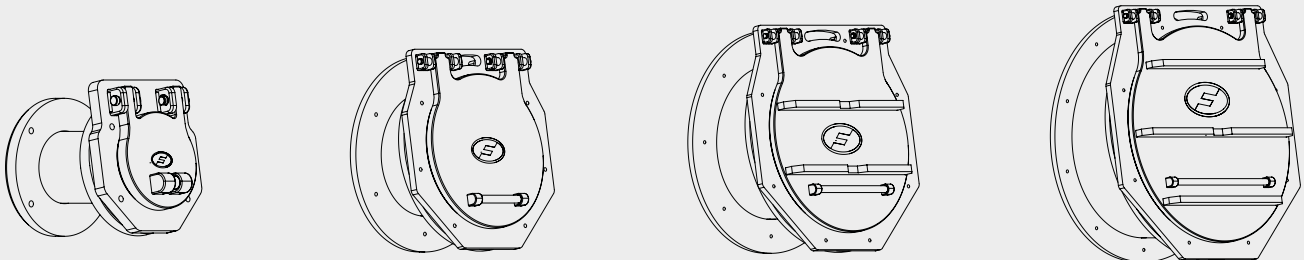

Product Code	DN	A (mm)	B (mm)	C (mm)	D (mm)	E (mm)	F (mm)	Mounting Hole PCD (mm)	Pressure (mwc)	Weight (kg)
FVT100	100	212	235	267	212	102	376	183	7	2.6
FVT150	150	274	291	279	260	148	419	221	7	3.8
FVT200	200	351	267	288	340	211	493	283	7	6.3
FVT225	225	379	392	288	370	235	517	311	7	6.8
FVT250	250	379	392	296	385	263	521	333	7	6.8
FVT300	300	429	442	300	450	300	567	383	7	8.5
FVT400	400	544	565	367	595	422	788	523	7	17.2
FVT500	500	685	698	393*	695	526	868	628	7	23.6
FVT600	600	754	770	405*	780	591	930	705	7	28.8

*Dimension taken from the back of the wall plate to front plate rib.

Mounting Sets

Tidal Wall Mounted Flap Valve	Mounting Holes	Size	Part Code
FVT100	4	M8	FVMS-01
FVT150	5	M8	FVMS-02
FVT200			
FVT225			
FVT250	6	M8	FVMS-03
FVT300			
FVT400	8	M8	FVMS-04
FVT500	10	M8	FVMS-05
FVT600			

FVMS-01



Flange Mounted Flap Valve (FVF)



Tidal Flange Mounted Flap Valve (FVTF)



Tidal flap valves are required when the connecting pipework is subject to a gradient or located in coastal and tidal areas. The Tidal valve's construction, featuring a 10-degree inclination accounts for changes in pressure and current. This ensures the flap door remains securely closed in its natural position, without being impacted by surrounding conditions, ensuring optimal performance and preventing reverse flow.

Pipe DN	Flange Options		Description
	Flange	Tidal Flange (10 °)	
DN100	FVF100-1	FVTF100-1	DN100 BS4504 / ISO 7005 (DIN) PN10/PN16
	FVF100-2	FVTF100-2	DN100 AS2129 Table C/D AS4087 PN14/PN16
DN125	FVF125-1	FVTF125-1	DN125 BS4504 / ISO 7005 (DIN) PN10/PN16
	FVF125-2	FVTF125-2	DN125 AS2129 Table C/D/E AS4087 PN14/PN16
DN150	FVF150-1	FVTF150-1	DN150 BS4504 / ISO 7005 (DIN) PN10/PN16
	FVF150-2	FVTF150-2	DN150 AS2129 Table C/D AS4087 PN14/PN16
DN200	FVF200-1	FVTF200-1	DN200 BS4504 / ISO 7005 (DIN) PN10
	FVF200-2	FVTF200-2	DN200 BS4504 / ISO 7005 (DIN) PN16
	FVF200-3	FVTF200-3	DN200 AS2129 Table C/D AS4087 PN14/PN16
DN250	FVF250-1	FVTF250-1	DN250 BS4504 / ISO 7005 (DIN) PN10
	FVF250-2	FVTF250-2	DN250 BS4504 / ISO 7005 (DIN) PN16
	FVF250-3	FVTF250-3	DN250 AS2129 Table C/D AS4087 PN14/PN16
DN300	FVF300-1	FVTF300-1	DN300 BS4504 / ISO 7005 (DIN) PN10
	FVF300-2	FVTF300-2	DN300 BS4504 / ISO 7005 (DIN) PN16
	FVF300-3	FVTF300-3	DN300 AS2129 Table C/D/E AS4087 PN14/PN16
DN350	FVF350-1	FVTF350-1	DN350 BS4504 / ISO 7005 (DIN) PN10
	FVF350-2	FVTF350-2	DN350 BS4504 / ISO 7005 (DIN) PN16
	FVF350-3	FVTF350-3	DN350 AS2129 Table C/D/E
DN400	FVF400-1	FVTF400-1	DN400 BS4504 / ISO 7005 (DIN) PN10
	FVF400-2	FVTF400-2	DN400 BS4504 / ISO 7005 (DIN) PN16
	FVF400-3	FVTF400-3	DN400 AS2129 Table C/D/E AS4087 PN14/PN16
DN450	FVF450-1	FVTF450-1	DN450 BS4504 / ISO 7005 (DIN) PN10
	FVF450-2	FVTF450-2	DN450 AS2129 Table C/D/E AS4087 PN14/PN16
	FVF450-3	FVTF450-3	DN450 AS2129 Table C/D/E AS4087 PN14/PN16
DN500	FVF500-1	FVTF500-1	DN500 BS4504 / ISO 7005 (DIN) PN10
	FVF500-2	FVTF500-2	DN500 BS4504 / ISO 7005 (DIN) PN16
	FVF500-3	FVTF500-3	DN500 AS2129 Table C/D/E
DN600	FVF600-1	FVTF600-1	DN600 BS4504 / ISO 7005 (DIN) PN10
	FVF600-2	FVTF600-2	DN600 BS4504 / ISO 7005 (DIN) PN16
	FVF600-3	FVTF600-3	DN600 AS2129 Table C/D AS4087 PN14/PN16

Other flange adaptors can be manufactured on request

Product drawings available for approval at quoting stage

HDPE Benefits

- High strength to density ratio due to low relative molecular branching, giving the material stronger intermolecular forces higher tensile strength.
- Exceptionally durable material that is resistant to impact and weather conditions.
- Very low moisture absorption rate, improving suitability in maritime and submerged environments.
- Recyclable material, while having no scrap value, eliminating the risk of theft.
- Resistant to most common chemicals, acids, bases and solvents due to the inherent chemical inertness of the material.
- The material is UV stable meaning it is resistant to degradation from sunlight exposure.
- Non-toxic, inert material that is safe for use in water systems.
- HDPE has an operating temperature of -30 degrees Celsius to 130 degrees Celsius.
- Lighter weight than traditional cast iron or stainless steel flap valved leading to safer and easier installation and lower costs.

Product Characteristics

Handle to aid installation & handling



EPDM Co-extrusion seal

(Flap Valves below DN150 consist of an EN681 EPDM front seal and a rear EPDM sponge gasket)

Cracking Head

Nominal Diameter	Wall/Flange Mounted		Spigot/Tidal Mounted	
	Maximum Opening Pressure (Cracking Head) Above Water* (mm)	Inclination (°)	Maximum Opening Pressure (Cracking head) Above Water* (mm)	Inclination (°)
100	26	0	50	10
125	25	0	50	10
150	24	0	50	10
200	23	0	50	10
225	22	0	52	10
250	22	0	54	10
300	22	0	57	10
350	22	0	61	10
400	22	0	61	10
450	22	0	65	10
500	22	0	69	10
600	22	0	76	10
700	48	0	-	-
800	48	0	-	-
900	48	0	-	-
1000	48	0	-	-

*These values do not take into account any disturbing external factors such as currents or bulky debris.

Product Specification for Flap Valve

Product Code(s)	FVXXX, FVSXXX, FVTXXX, FVFXXX or FVTFXXX
Description	Wall, Spigot, Tidal or Flange Mounted Flap Valves
Size Range	DN100 to DN1000
Materials	HDPE Backplate and Flap EPDM integrated seal conforming to BS EN 681-1:1996 Stainless Steel (316) Glass filled nylon (GFN)
Standards	Fernco Flap Valves exceed the requirements of DIN19569-4, ISO 9001:2015 and BS7775
Recommended Max Temperature	Constant 80°C Intermittent 100°C



Installation



Scan for installation video



Installation Guide - Wall Mounted Flap Valve

- Offer the Flap Valve to the wall in the desired fixing position, ensuring the hinges are at 12 o'clock.
- Mark the drill positions where the wall mounting holes are present, use a spirit level to ensure the Flap Valve is level.
- Remove the Flap Valve and drill holes where marked using a suitable hammer drill. Use the correct size drill bit as indicated in table 1. Ensure the hole depth is consistent with the requirements indicated in table 1.
- Dust and debris must be cleaned from all drilled holes and the wall surface.
- Carefully insert the resin capsules into the drilled holes.
- Attach the threaded rod into the chuck of a suitable hammer drill, drive the threaded rod into the capsule until it reaches the bottom of the hole.
- Detach the drill from the threaded rod and remove excess residue from around the hole. Leave the resin to cure, curing time is indicated in table 2.
- 8/9. Offer the Flap Valve over the threaded rods, tighten the supplied washers and nuts to the recommended torque as given in table 1.

Table 1: Wall Mounting Kit Installation Requirements

Bolt Size	Drill Bit Required	Drilled Depth	Recommended Tightening Torque
M8	10mm	80mm	4Nm
M12	14mm	100mm	8Nm

Table 2: Resin Capsule Cure Time

Temp °C	-15 – -10	-9 – -5	-4 – 0	+1 – +5	+6 – +10	+11 – +20	+21 – +30	+31 – +40
Cure Time	30 h	16 h	10 h	45 min	30 min	20 min	5 min	3 min

*It is important that you confirm the OD and ID of the pipe you are installing onto, to ensure we can specify the correct Flap Valve.



Scan for
installation
video

Installation

Installation Guide - Spigot Mounted Flap Valve using Shearbanded Coupling

1. Ensure the pipe has a straight/flat end face.
2. Clean the outer pipe surface leaving a smooth surface for the coupling to seal onto.
3. Measure the coupling width, mark half this measurement on both the flap valve spigot and connecting pipe.
4. If using a bush slide the bush onto the Flap Valve spigot until the edge of the bush and the marked line are flush.
5. Slide the coupling over the bush until the end faces are flush and hand tighten the end clamp. If no bush is required slide the coupling onto the spigot until the edge of the coupling and marked line are flush then hand tighten the end clamp.
6. Butt the Flap Valve spigot up to the main pipe, the coupling should now be in-line with the line previously marked on the pipe. Ensure the Flap Valve is in the correct orientation (hinge mechanism at 12 o'clock) then hand tighten the end clamp.
7. Tighten all clamp bands to the recommended torque (stated by the coupling label) in sequence across the width of the coupling, starting with the shear band.

1-2



3

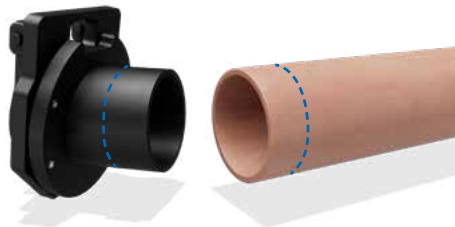

4

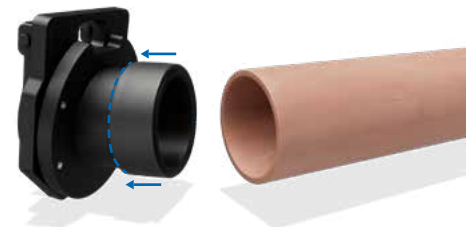

5



6

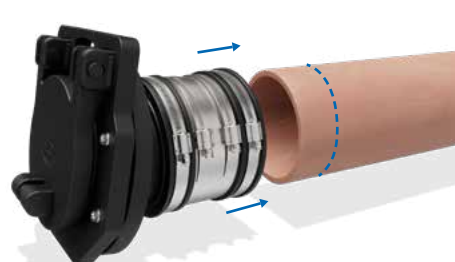

7



Close Up



It is important that you confirm the OD and ID of the pipe you are installing onto, to ensure we can specify the correct Flap Valve.



Scan for installation video

Installation

Installation Guide - Spigot Mounted Flap Valve using Sealing Tape

1. Ensure the pipe end has a straight/flat surface for mounting.
2. Clean away any debris from the internal surface of the pipe.
3. Take the Sealing tape supplied with the Flap Valve, peel away the self-adhesive backing and wrap around the external surface of the Flap Valve spigot.
4. Ensure the outside diameter of the tape is now approximately 5mm larger than the internal diameter of the pipe to ensure a compressive fit.
5. Insert the spigot section of the Flap Valve into the pipe until the pipe end is flush with the Flap Valves back plate. When inserting ensure the Flap Valve hinge mechanism is at 12 o'clock.



Sealing Tape Sizes

Finished Product	Part Code	Description	Quantity (Metres)
EPDM Sealing Strip	FVSMS-01	EPDM Spigot Sealing Strip For Flap Valve Spigots DN100, DN125, DN150	2.05m
EPDM Sealing Strip	FVSMS-02	EPDM Spigot Sealing Strip For Flap Valve Spigots DN200, DN225, DN250	4.52m
EPDM Sealing Strip	FVSMS-03	EPDM Spigot Sealing Strip For Flap Valve Spigots DN300, DN350, DN400	6.14m
EPDM Sealing Strip	FVSMS-04	EPDM Spigot Sealing Strip For Flap Valve Spigots DN450, DN500, DN600	10m

Installation Guide - Flange Mounted Flap Valve

1. Using the corresponding flange installation kit (not provided), attach the Flange Adaptor to the flange. (Please ensure the flange is installed in the correct orientation. The Flap Valve's final position should be with it's hinge mechanism in the 12 o'clock position).
2. Align the mounting holes on the Flap Valve with the corresponding adaptor bolts, and then slide the Flap Valve over.

3. Using the washer and nuts provided tighten the Flap Valve into position. Ensure the is done equally and alternately (recommended torque of 4Nm).

Note: If the connecting pipework is subject to any gradient, then a tidal flange flap valve should be used.

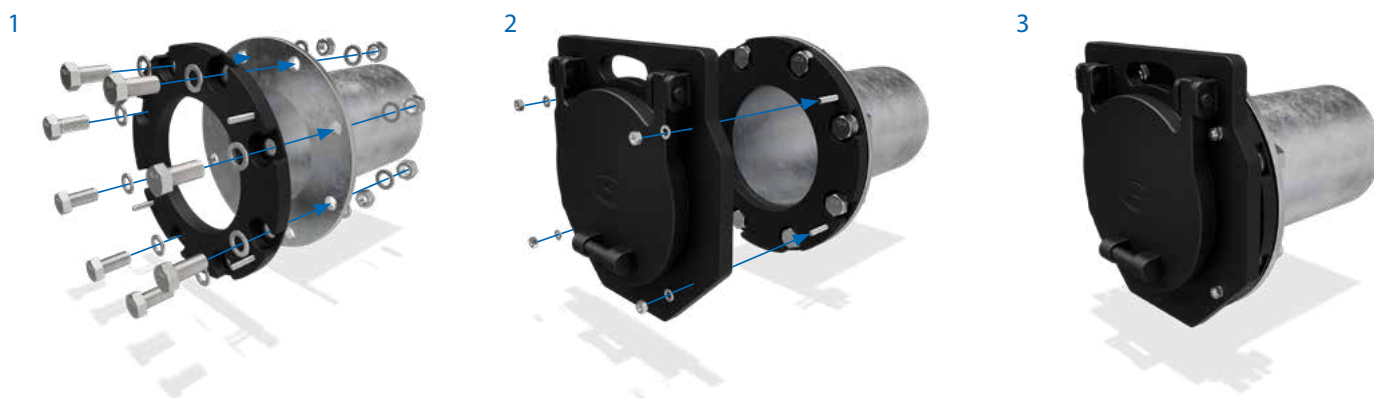

Installation Guide - Tidal Wall Mounted Flap Valve

1. Offer the Flap Valve to the wall in the desired fixing position, ensuring the top fixing is at 12 o'clock.
2. Mark on the wall the drill positions where the wall mounting holes are present, use a spirit level to ensure the Flap Valve is level.
3. Remove the Flap Valve and drill holes where marked using a suitable hammer drill and the correct size drill bit as indicated in table 1. Ensure the hole depth for all holes is consistent as shown in table 1.
4. Dust and debris must be cleaned from all drilled holes and the wall surface.

5. Carefully insert the resin capsules into the drilled holes.
6. Attach the threaded rod into the chuck of a suitable hammer drill, drive the threaded rod into the capsule until it reaches the bottom of the hole.
7. Detach the drill from the threaded rod and remove excess residue from around the hole. Leave the resin to cure, curing time is indicated in table 2.
8. Offer the Flap Valve over the threaded rod, tighten the supplied washers and nuts to the recommended torque as given in the table 1.



Table 1: Wall Mounting Kit Installation Requirements

Bolt Size	Drill Bit Required	Drilled Depth	Recommended Tightening Torque
M8	10mm	80mm	4Nm

Table 2: Resin Capsule Cure Time

Temp °C	-15 – -10	-9 – -5	-4 – 0	+1 – +5	+6 – +10	+11 – +20	+21 – +30	+31 – +40
Cure Time	30 h	16 h	10 h	45 min	30 min	20 min	5 min	3 min

**It is important that you confirm the OD and ID of the pipe you are installing onto, to ensure we can specify the correct Flap Valve.*

General Information

Quality, Standards and Approvals

Fernco has been certified by the British Standards Institution (BSI) as a company of assessed capability, with a quality management system which meets the requirements of BS EN ISO 9001:2015

Fernco UK, part of a global group of companies, are the leaders in wastewater connection innovation; utilising the most advanced methods and techniques for precision-manufactured products, all of which comply with or exceed relevant British and European standards to ensure reliability and sustainability.

Environment

Fernco operate Environmental Management Systems which are certified to ISO 14001: 2015.

Supply

Fernco are proud members of the Builders Merchants Federation (BMF). All Fernco products are supplied through a national and global network of distribution and merchant partners. For stockist details, contact Fernco.

Technical Support

Fernco have a team of product experts on hand to support all customers with technical support and advice.

Contact Fernco Technical Department:

Tel: +44 (0) 1226 344100

Email: technical@fernco.co.uk

Enquiries

UK Sales:

Tel: +44 (0) 1226 340 888

Email: sales@fernco.co.uk

International Sales:

Tel: +44 (0) 1226 344 105

Email: export.dept@fernco.co.uk