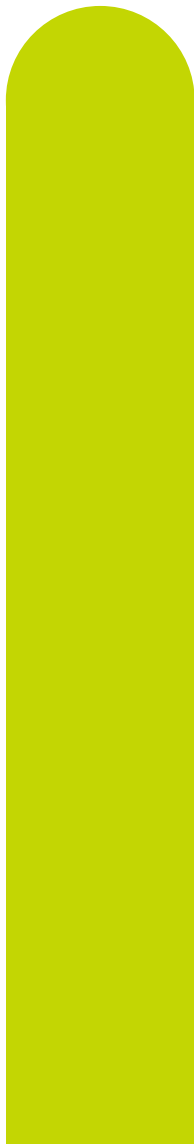


2600

User Manual



2604 Process Controller

HA026761/5
April 2013

© 2013 Eurotherm Limited

All rights are strictly reserved. No part of this document may be reproduced, modified, or transmitted in any form by any means, nor may it be stored in a retrieval system other than for the purpose to act as an aid in operating the equipment to which the document relates, without the prior, written permission of Eurotherm Limited.



Eurotherm Limited pursues a policy of continuous development and product improvement. The specification in this document may therefore be changed without notice. The information in this document is given in good faith, but is intended for guidance only. Eurotherm Limited will accept no responsibility for any losses arising from errors in this document.

MODEL 2604 CONTROLLER

USER MANUAL

List of Chapters

	Warning Back up Battery.....	9
1.	CHAPTER 1 INTRODUCTION	10
2.	CHAPTER 2 INSTALLATION	13
3.	CHAPTER 3 FUNCTION BLOCKS	20
4.	CHAPTER 4 SOFT WIRING	21
5.	CHAPTER 5 ACCESS LEVELS	25
6.	CHAPTER 6 INSTRUMENT CONFIGURATION	27
7.	CHAPTER 7 PROGRAMMER CONFIGURATION	38
8.	CHAPTER 7 DIGITAL PROGRAMMER.....	58
9.	CHAPTER 8 ALARM CONFIGURATION.....	61
10.	CHAPTER 10 LOOP SET UP	74
11.	LOOP SETUP (WIRING PAGE) FOR CASCADE LOOP	93
12.	CHAPTER 12 TUNING.....	103
13.	CHAPTER 13 CONTROLLER APPLICATIONS	114
14.	CHAPTER 12 INPUT OPERATORS.....	124
15.	CHAPTER 13 TIMER, CLOCK, TOTALISER, OPERATION.....	135
16.	CHAPTER 16 ADVANCED FUNCTIONS	145
17.	CHAPTER 17 ANALOGUE OPERATORS	156
18.	CHAPTER 18 LOGIC OPERATORS	158
19.	CHAPTER 19 DIGITAL COMMUNICATIONS	160
20.	CHAPTER 20 MASTER COMMUNICATIONS	163
21.	CHAPTER 21 STANDARD IO	172
22.	CHAPTER 22 MODULE IO.....	183
23.	CHAPTER 21 TRANSDUCER SCALING	212
24.	CHAPTER 22 IO EXPANDER.....	220
25.	CHAPTER 23 DIAGNOSTICS.....	222
26.	CHAPTER 24 CALIBRATION	223
27.	APPENDIX A ORDER CODE	233
28.	APPENDIX B SAFETY AND EMC INFORMATION	235
29.	APPENDIX C TECHNICAL SPECIFICATION	239
30.	APPENDIX D PARAMETER UNITS AND ADDRESSES	249
31.	APPENDIX E CASCADE TRIM MODE - EARLIER CONTROLLERS	253
32.	DECLARATION OF CONFORMITY	254

Contents

1.	CHAPTER 1 INTRODUCTION	9
1.1	about this manual	10
1.1.1	The Structure Of This Manual	10
1.2	What is 2604	11
1.3	general view of 2604 controller	12
2.	CHAPTER 2 INSTALLATION	13
2.1	MECHANICAL INSTALLATION	13
2.1.1	Positioning	13
2.1.2	Outline dimensions Model 2604	13
2.1.3	Mounting the Controller	14
2.1.4	Unplugging and Plugging in the Controller	14
2.2	I/O MODULES	15
2.2.1	To Add or Change Modules	15
2.3	WIRING	16
2.3.1	Electrical Connections	16
2.3.2	Rear Terminal Layout	16
2.4	Rear Terminals	17
2.5	STANDARD CONNECTIONS	18
2.5.1	Power Supply Wiring	18
2.5.2	Relay Output	18
2.5.3	Sensor Input Connections	19
2.5.4	Analogue Input Connections	20
2.5.5	I/O Expander (or Additional Digital Input)	21
2.5.6	Digital I/O	22
2.6	OPTIONAL PLUG IN MODULE CONNECTIONS	23
2.6.1	Digital Communications Connections	23
2.6.2	Devicenet Wiring	25
2.6.3	I/O Modules	27
2.7	TO CONNECT ZIRCONIA (DUAL SIGNAL) PROBE	31
2.7.1	Zirconia Probe Screening	32
2.8	Operator Interface - Overview	33
2.8.1	Readouts and Indicators	33
2.8.2	LED Status Indicators	34
2.8.3	Operator Buttons	35
2.9	Parameters and how to Access Them	36
2.9.1	Pages	36
2.9.2	To Step Through Page Headers	37
2.9.3	Sub-headers	37
2.9.4	To Step Through Parameters	38
2.9.5	To Change Parameter Values	39
2.9.6	Confirmation Mechanism	40
2.10	backpage	41
2.11	backscroll	41
2.12	Jump to Home Display	41
2.13	Invalid key actions	41
2.14	Parameter Tables	42
2.15	parameter availability and alterability	42
2.16	NAVIGATION DIAGRAM	17
3.	CHAPTER 3 FUNCTION BLOCKS	20
3.1	What is a Function Block?	20
3.1.1	Inputs	20
3.1.2	Outputs	20
3.1.3	Settings	20
4.	CHAPTER 4 SOFT WIRING	21
4.1	What is soft wiring?	21
4.1.1	An Example of Soft Wiring	21
4.1.2	Configuration of the Simple PID Loop	22
5.	CHAPTER 5 ACCESS LEVELS	25
5.1	The Different access levels	25
5.2	passcodes	25
5.3	To enter configuration level	26
5.4	To enter new passcodes	26
5.5	to exit configuration level	26
6.	CHAPTER 6 INSTRUMENT CONFIGURATION	27
6.1	what is instrument configuration?	27
6.1.1	To Select the Instrument Configuration Pages	27
6.2	To configure controller options	27

6.2.1	INSTRUMENT Options Page	28
6.2.2	INSTRUMENT Info Page	29
6.2.3	INSTRUMENT Units Page	29
6.2.4	29
6.2.5	INSTRUMENT Display Page	30
6.2.6	INSTRUMENT Page Promote Page	31
6.2.7	INSTRUMENT User Text Page	32
6.2.8	INSTRUMENT Summary Page	33
6.2.9	INSTRUMENT Standby Page	34
6.3	User text examples	35
6.3.1	To Re-Name Loop 1 to Zone 1	35
6.3.2	To Re-Name User Alarm 1 and Provide a Message	35
6.3.3	To Re-Name Module 1 to be called Heat Output	35
6.3.4	To Show User Text in the Summary Page on an Event	36
6.3.5	To Assign Custom Units to the Power Up Display	36
6.3.6	To Customise the Power Up Display	37
7.	CHAPTER 7 PROGRAMMER CONFIGURATION	38
7.1	What is setpoint programming ?	38
7.2	The 2604 setpoint programmer Definitions	39
7.2.1	Run	39
7.2.2	Hold	39
7.2.3	Reset	39
7.2.4	Servo	39
7.2.5	Hot Start	39
7.2.6	Digital Inputs	39
7.2.7	Power Fail Recovery	40
7.2.8	Wait	41
7.2.9	Holdback (Guaranteed Soak)	42
7.2.10	Fine and Coarse Holdback	42
7.3	PROGRAM USER VALUES	43
7.3.1	Program User Value Enumerations	43
7.4	Programmer types	43
7.4.1	Time To Target Programmer	43
7.4.2	Ramp Rate Programmer	43
7.5	Segment Types	44
7.5.1	Profile	44
7.5.2	Go Back Segment	44
7.5.3	End Segment	44
7.6	To enable the programmer function block	45
7.7	To Configure Program Type	45
7.7.1	PROGRAM EDIT Options Page	46
7.8	PROFILE LOCK	47
7.9	Programmer wiring	48
7.9.1	Programmer Function Block	48
7.9.2	PROGRAM EDIT Wiring Page	49
7.10	TO CREATE OR EDIT A PROGRAM	50
7.10.1	Parameters Common To A Program	50
7.10.2	PROGRAM EDIT Program Page	50
7.10.3	Parameters Common To Each Segment	51
7.10.4	PROGRAM EDIT Segment Page	51
7.10.5	Run Parameters	53
7.11	Programmer Wiring Examples	56
7.11.1	One Profile, Three Loops	56
7.11.2	Two Profiles, Two Loops	57
8.	CHAPTER 7 DIGITAL PROGRAMMER	58
8.1	WHAT IS THE DIGITAL PROGRAMMER?	58
8.2	TO EDIT THE DIGITAL PROGRAMMER	59
8.2.1	Digital Program Edit Page	59
8.2.2	Digital Program 1 to 4 Page	60
8.3	POWER FAIL RECOVERY	60
9.	CHAPTER 8 ALARM CONFIGURATION	61
9.1	DEFINITION OF ALARMS AND EVENTS	61
9.1.1	Customisable Parameter Names	61
9.2	Types of alarm used in 2604 controller	61
9.2.1	Full Scale High	61
9.2.2	Full Scale Low	61
9.2.3	Deviation High Alarm	62
9.2.4	Deviation Low Alarm	62
9.2.5	Deviation Band	62
9.2.6	Rate Of Change Alarm - Negative Direction	63
9.2.7	Rate Of Change Alarm - Positive Direction	63
9.3	Blocking Alarms	64

9.3.1	Full Scale Low With Blocking	64
9.3.2	Full Scale High Alarm With Blocking.....	64
9.3.3	Deviation Band With Blocking	64
9.4	Latching alarms	65
9.4.1	Latched Alarm (Full Scale High) With Automatic Reset	65
9.4.2	Latched Alarm (Full Scale High) With Manual Reset	65
9.4.3	Grouped Alarms.....	65
9.5	HOW ALARMS ARE INDICATED	66
9.5.1	Alarm Delay Time.....	66
9.6	To configure Loop 1 alarm type.....	67
9.7	alarm tables	68
9.7.1	ALARMS (Summary Page).....	68
9.7.2	ALARMS <i>LP1</i> (2 or 3) Page Parameters.....	69
9.7.3	ALARMS (PV Input Page) Parameters	70
9.7.4	ALARMS (An Input Page) Parameters	70
9.7.5	ALARMS (Module 1,3, 4, 5 & 6 Page) Parameters	70
9.7.6	ALARMS (User 1 to 8 Page) Parameters	71
9.8	Alarm wiring examples	72
9.8.1	Control Loop With High and Low Alarms	72
9.8.2	Loop Alarm Inhibited if Programmer not in Run.....	73
10.	CHAPTER 10 LOOP SET UP	74
10.1	WHAT IS LOOP SET UP.....	74
10.1.1	LOOP SET UP (Options page)	74
10.2	SINGLE LOOP CONTROL.....	78
10.2.1	LOOP SET UP (Wiring page) SINGLE LOOP	78
10.3	SETPOINT DEFINITION	79
10.3.1	Setpoint Function Block.....	79
10.3.2	Setpoint Parameters.....	80
10.3.3	<i>LP1</i> SETUP (SP Aux) Page	80
10.4	PID CONTROL	81
10.4.1	Proportional Term.....	81
10.4.2	Integral Term	81
10.4.3	Derivative Term.....	81
10.4.4	High and Low Cutback.....	81
10.4.1	PID Block Diagram.....	82
10.4.1	Remote (External) OP Feedback	82
10.4.2	Analogue Value.....	82
10.5	GAIN SCHEDULING	83
10.5.1	To Configure Gain Scheduling:-.....	83
10.5.2	PID Parameters.....	84
10.5.3	PID (Aux) Parameters.....	85
10.6	OUTPUT PARAMETERS	86
10.6.1	Table of Output Parameters.....	86
10.7	MOTORISED VALVE CONTROL.....	87
10.7.1	Motor Parameters	87
10.8	DIAGNOSTICS	88
10.8.1	Diagnostic Page	88
10.9	DISPLAY	89
10.9.1	Display Page.....	89
10.10	CASCADE CONTROL.....	90
10.10.1	Overview	90
10.10.2	Full Scale Cascade Mode	90
10.10.3	Trim Mode.....	91
10.10.4	Auto/Manual Operation in Cascade.....	91
10.10.5	Cascade Controller Block Diagrams.....	92
11.	LOOP SETUP (WIRING PAGE) FOR CASCADE LOOP	93
11.1.1	Cascade Parameters.....	94
11.1.2	Cascade Wiring Example	95
11.2	RATIO CONTROL.....	96
11.2.1	Overview	96
11.2.2	Basic Ratio Control	96
11.2.3	Controller Configured For Ratio	96
11.2.4	Ratio Parameters.....	97
11.2.5	Ratio Wiring Example.....	98
11.3	OVERRIDE CONTROL	99
11.3.1	Overview	99
11.3.2	Simple Override.....	99
11.3.3	Controller Configured For Override	99
11.3.4	Override Parameters.....	100
11.3.5	Override Wiring Example.....	101
11.4	LOOP2 SET UP.....	102
11.5	LOOP3 SET UP.....	102

12.	CHAPTER 12 TUNING.....	103
12.1	WHAT IS TUNING	103
12.2	AUTOMATIC TUNING	103
12.2.1	One-shot Tuning.....	103
12.3	TO AUTOTUNE CONTROL LOOP <i>LP1</i>	104
12.3.1	Carbon Potential Control	105
12.3.2	AutotuneParameters	105
12.3.3	How Tuning State is Displayed.....	106
	MANUAL TUNING.....	107
12.3.4	Setting the cutback values	108
12.3.5	Integral action and manual reset	108
12.3.6	Valve Position Control.....	108
12.4	TUNING WHEN GAIN SCHEDULING IS USED	109
12.4.1	Tuning Procedure.....	109
12.5	CASCADE TUNING.....	110
12.5.1	To Tune a Full Scale Cascade Loop.....	110
12.5.2	To Tune a Trim mode Cascade Loop.....	112
13.	CHAPTER 13 CONTROLLER APPLICATIONS	114
13.1	ZIRCONIA - CARBON POTENTIAL CONTROL.....	114
13.1.1	Temperature Control	114
13.1.2	Carbon Potential Control	114
13.1.3	Sooting Alarm	114
13.1.4	Automatic Probe Cleaning.....	114
13.1.5	Endothermic Gas Correction	114
13.1.6	Example of Carbon Potential Controller Connections	115
13.2	TO VIEW AND ADJUST ZIRCONIA PARAMETERS	115
13.2.1	Zirconia Parameters.....	116
13.2.2	Wiring Page	117
13.3	ZIRCONIA WIRING EXAMPLE.....	117
13.3.1	The Zirconia Function Block.....	117
13.3.2	Configuration of a Carbon Potential Control Loop.....	118
13.3.3	Probe Impedance.....	119
13.4	HUMIDITY CONTROL.....	120
13.4.1	Overview	120
13.4.2	Example Of Humidity Controller Connections	120
13.4.3	Temperature Control Of An Environmental Chamber	120
13.4.4	Humidity Control Of An Environmental Chamber	120
13.5	TO VIEW AND ADJUST HUMIDITY PARAMETERS	121
13.5.1	Humidity Options Parameters	121
13.5.2	Wiring Page	121
13.6	HUMIDITY WIRING EXAMPLE.....	122
13.6.1	The Humidity Function Block.....	122
13.6.2	Configuration of a Humidity Control Loop.....	122
14.	CHAPTER 12 INPUT OPERATORS.....	124
14.1	WHAT ARE INPUT OPERATORS.....	124
14.2	CUSTOM LINEARISATION	125
14.2.1	Compensation for Sensor Non-Linearities	125
14.2.2	To Create a Linearised Input.....	126
14.2.3	Input Operators Custom Linearisation Parameters.....	127
14.3	THERMOCOUPLE/PYROMETER SWITCHING.....	128
14.3.1	To Set Up Thermocouple/Pyrometer Switching Points.....	129
14.3.2	Input Operators Switch Over Parameters.....	129
14.4	the monitor block	130
14.4.1	Input Operators Monitor Parameters	130
14.5	BCD INPUT	131
14.5.1	Main Features.....	131
14.5.2	BCD Parameters.....	131
14.6	INPUT OPERATORS WIRING EXAMPLES	132
14.6.1	Switch Over Loop With Custom Linearised Input	132
14.6.2	Configuring the BCD Input to Select a Program	133
14.6.3	Holdback Duration Timer.....	134
15.	CHAPTER 13 TIMER, CLOCK, TOTALISER, OPERATION.....	135
15.1	WHAT ARE TIMER BLOCKS?	135
15.2	TIMER TYPES	136
15.2.1	On Pulse Timer Mode	136
15.2.2	Off Delay Timer Mode	137
15.2.3	One Shot Timer Mode	138
15.2.4	Minimum On Timer Mode.....	139
15.3	TO VIEW AND ADJUST TIMER PARAMETERS	140
15.3.1	Timer Parameters.....	140
15.4	THE CLOCK.....	141

15.4.1	Clock Parameters.....	141
15.5	TIME BASED ALARMS.....	142
15.5.1	Timer Alarm Parameters.....	142
15.6	TOTALISERS.....	143
15.6.1	Totaliser Parameters.....	143
15.7	APPLICATION EXAMPLE.....	144
15.7.1	Compressor Timer.....	144
16.	CHAPTER 16 ADVANCED FUNCTIONS.....	145
16.1	PATTERN GENERATOR.....	145
16.1.1	Example: Programmer Event Outputs.....	145
16.2	ANALOGUE SWITCHES.....	147
16.2.1	To Set up an Analogue Switch.....	147
16.2.2	Analogue Switch Parameters.....	148
16.3	USER VALUES.....	149
16.3.1	To Access User Values.....	149
16.3.2	User Values Parameter Table.....	149
16.4	USER MESSAGES.....	150
16.4.1	To Configure A User Message.....	151
16.5	USER SWITCHES.....	152
16.5.1	To Configure User Switches.....	152
16.6	CUSTOM ENUMERATIONS.....	153
16.6.1	To Configure Custom Enumerations.....	153
17.	CHAPTER 17 ANALOGUE OPERATORS.....	156
17.1	WHAT ARE ANALOGUE OPERATORS?.....	156
17.1.1	Analogue Operations.....	156
17.2	TO CONFIGURE ANALOGUE OPERATORS.....	157
17.2.1	Analogue Operator Parameters.....	157
18.	CHAPTER 18 LOGIC OPERATORS.....	158
18.1.1	Logic Operations.....	158
18.2	TO CONFIGURE LOGIC OPERATORS.....	158
18.2.1	Logic Operator Parameters.....	159
19.	CHAPTER 19 DIGITAL COMMUNICATIONS.....	160
19.1	WHAT IS DIGITAL COMMUNICATIONS?.....	160
19.2	TO CONFIGURE COMMUNICATIONS PARAMETERS.....	160
19.2.1	H Module Parameters.....	161
19.2.2	J Module Parameters.....	161
19.3	DIGITAL COMMUNICATIONS DIAGNOSTICS.....	162
20.	CHAPTER 20 MASTER COMMUNICATIONS.....	163
20.1	INTRODUCTION.....	163
20.1.1	Broadcast Communications.....	163
20.1.2	Direct read/write.....	163
20.2	WIRING CONNECTIONS.....	164
20.2.1	Example Wiring Diagrams for Different Slaves.....	165
20.3	cross-board version.....	167
20.4	Basic Navigation.....	167
20.5	To Configure Parameters.....	168
20.6	To Configure Slaves.....	169
20.7	Parameter Tables.....	169
20.8	additional notes.....	171
20.8.1	IEEE in 2000 Series.....	171
20.8.2	Configuration mode.....	171
21.	CHAPTER 21 STANDARD IO.....	172
21.1	WHAT IS STANDARD IO?.....	172
21.2	PV Input.....	173
21.2.1	To Configure Input Channel Type.....	173
21.2.2	Standard IO <i>PV Input</i> Parameters.....	174
21.2.3	PV Input Scaling.....	175
21.2.4	Offset.....	175
21.2.5	To Scale a Linear PV Input.....	176
21.2.6	To View and Change Input Filter Time.....	176
21.3	ANALOGUE INPUT.....	177
21.3.1	To Scale the Analogue Input.....	177
21.3.2	Standard IO <i>Analogue Input</i> Parameters.....	177
21.3.3	Sensor Break Value.....	178
21.4	THE FIXED RELAY OUTPUT PARAMETERS.....	178
21.4.1	Fixed Relay Output Scaling.....	178
21.4.2	To Set up and Scale the Fixed Relay Output.....	179
21.4.3	Standard IO <i>AA Relay</i> Parameters.....	180
21.5	STANDARD IO DIG I/O PARAMETERS.....	181

21.5.1	Standard <i>Digital IO</i> Parameters	181
21.6	STANDARD IO DIAGNOSTIC PARAMETERS	182
21.6.1	Standard IO Diagnostic Parameters Table	182
22.	CHAPTER 22 MODULE IO.....	183
22.1	WHAT IS MODULE IO?.....	183
22.2	MODULE IDENTIFICATION	184
22.2.1	Idents Page.....	184
22.3	MODULE IO PARAMETERS.....	185
22.3.1	DC Control and DC Retransmission	186
22.3.2	Relay Output.....	187
22.3.3	Triac Output.....	188
22.3.4	Triple Logic Output and Single Isolated Logic Output	189
22.3.5	Triple Logic and Triple Contact Input	190
22.3.6	Transmitter Power Supply	190
22.3.7	Transducer Power Supply	190
22.3.8	Potentiometer Input.....	191
22.3.9	PV Input.....	192
22.3.10	DC Input.....	193
22.3.11	Dual PV Input.....	194
22.3.12	Dual DC Output Module	196
22.3.13	High Resolution Retransmission Output.....	198
22.4	MODULE SCALING.....	203
22.4.1	The PV Input	203
22.4.2	To Scale a Linear PV Input:-	203
22.4.3	Output modules.....	204
22.4.4	To Scale A Control Output:-	205
22.4.5	Retransmission Output	206
22.4.6	To Scale a Retransmission Output	206
22.4.7	To Scale the Potentiometer input	207
22.5	MODULE IO WIRING EXAMPLES	209
22.5.1	To Configure Module 1 Channel A to Run a Program.....	209
22.5.2	To Operate a Relay from a Digital Input.....	209
22.5.3	Zirconia Probe Impedance Measurement.....	209
23.	CHAPTER 21 TRANSDUCER SCALING	212
23.1	WHAT IS TRANSDUCER SCALING?	212
23.2	SHUNT CALIBRATION	212
23.2.1	To Calibrate a Strain Gauge Bridge Transducer	213
23.3	LOAD CELL CALIBRATION	214
23.3.1	To Calibrate a Load Cell.....	214
23.4	COMPARISON CALIBRATION	215
23.4.1	To Calibrate a Controller Against a Second Reference.....	216
23.5	AUTO-TARE CALIBRATION	217
23.5.1	To Use the Auto-Tare Feature	217
23.6	TRANSDUCER SCALING PARAMETERS	218
23.6.1	Transducer Scaling Parameter Table	218
23.6.2	Parameter Notes	219
24.	CHAPTER 22 IO EXPANDER.....	220
24.1	WHAT IS IO EXPANDER?	220
24.2	TO CONFIGURE IO EXPANDER	220
24.2.1	IO Expander parameters.....	221
25.	CHAPTER 23 DIAGNOSTICS.....	222
25.1	WHAT IS DIAGNOSTICS?	222
25.1.1	Diagnostics parameters.....	222
26.	CHAPTER 24 CALIBRATION	223
26.1	USER CALIBRATION	223
26.2	PRECAUTIONS	223
26.3	PV INPUT.....	224
26.3.1	To Calibrate mV Range.....	224
26.3.2	Thermocouple Calibration.....	226
26.3.3	Voltage Calibration	226
26.3.4	High Z Voltage Calibration.....	226
26.3.5	RTD Calibration.....	227
26.3.6	Analogue Input Calibration	228
26.3.7	To Restore Factory Calibration Values	229
26.4	MODULE I/O	230
26.4.1	DC Output Module.....	230
26.4.2	PV Input Module	232
26.4.3	Dual PV Input Module.....	232
26.4.4	DC Input Module	232

27.	APPENDIX A ORDER CODE	233
27.1	hardware code	233
27.2	Configuration coding (optional)	234
27.3	Quick start code example:	234
28.	APPENDIX B SAFETY AND EMC INFORMATION.....	235
28.1	Safety	235
28.1.1	Electromagnetic compatibility.....	235
28.2	Service and repair	235
28.2.1	Electrostatic discharge precautions.....	235
28.2.2	Cleaning	235
28.3	Installation Safety Requirements.....	236
28.3.1	Safety Symbols	236
28.3.2	Personnel	236
28.3.3	Enclosure of live parts	236
28.3.4	Isolation	236
28.3.5	Wiring	237
28.3.6	Power Isolation.....	237
28.3.7	Earth leakage current.....	237
28.3.8	Overcurrent protection.....	237
28.3.9	Voltage rating.....	237
28.3.10	Conductive pollution.....	237
28.3.11	Over-temperature protection	237
28.3.12	Grounding of the temperature sensor shield	237
28.4	Installation requirements for EMC	238
28.4.1	Routing of wires	238
29.	APPENDIX C TECHNICAL SPECIFICATION.....	239
29.1	all analogue, dual and pv inputs.....	239
29.2	Precision PV input / Module.....	239
29.3	dual (probe) input module	240
29.4	Analogue input.....	240
29.5	analogue input module	240
29.6	Standard digital I/O.....	241
29.7	Digital input modules	241
29.8	Digital output modules.....	241
29.9	Analogue output Modules	241
29.10	Transmitter PSU	241
29.11	Transducer PSU.....	241
29.12	Dual DC Output.....	242
29.13	high resolution DC Output	242
29.14	Potentiometer input	242
29.15	Digital communications	242
29.16	Alarms.....	242
29.17	User messages	242
29.18	Control functions	242
29.19	Setpoint programmer.....	243
29.20	Advanced functions.....	243
29.21	General specification.....	243
29.22	graphical representation of errors	244
29.22.1	mV Input.....	244
29.22.2	Mid range high impedance Input	245
29.22.3	High Level Input.....	246
29.22.4	RTD (Pt-100) Input type.....	247
29.22.5	Thermocouple Input type.....	248
30.	APPENDIX D PARAMETER UNITS AND ADDRESSES	249
30.1	COMMONLY USED PARAMETERS.....	249
30.2	PARAMETER UNITS.....	252
30.3	MODULE STATUS MESSAGES.....	252
31.	APPENDIX E CASCADE TRIM MODE - EARLIER CONTROLLERS	253
31.1	CASCADE PARAMETERS.....	253
32.	DECLARATION OF CONFORMITY	254



Warning

Back up Battery

This instrument is fitted with a battery designed to retain configuration and other settings in the event of a failure of the instrument power supply.

This battery has an expected life of 10 years minimum at a nominal ambient working temperature (e.g. 25°C).

The battery life may be reduced if it is consistently operated in an elevated ambient temperature environment.

Maintenance Schedule

A battery failure is only evident following a failure of the instrument power supply.

The battery should be replaced at regular intervals. Between 6 and 10 years is recommended depending on usage and operating temperature. The battery is not user serviceable, contact your local service centre to make suitable arrangements.

On older instruments contact your supplier to have the battery replaced prior to failure. The age of the instrument is shown on the side label. This contains a serial number, where the last four characters either show the week number and year of manufacture WW YY, or a date in the format UK YYWW.

It is important to maintain a record of instrument configurations or use Eurotherm iTools to make clone copies of fully working instruments. This is described in the iTools Help Manual HA028838 which may be downloaded from www.eurother.co.uk. Store this securely as a back up to be used to restore the configuration.

1. CHAPTER 1 INTRODUCTION

Thank you for selecting the 2604 High Performance Programmer/Controller. This chapter provides an overview of your controller including how to change modules and the principle of operation of the user interface.

1.1 ABOUT THIS MANUAL

This manual is intended for those who wish to configure the controller.

Installation and operation of the controller is described in the Installation and Operation Handbook, Part No. HA026491 supplied with the controller.

Access to the parameters in the controller is achieved through five levels of security. The levels of access are:-

Level 1	Operation only. This level allows, for example, parameters to be changed within safe limits or programmers to be run, held or reset.
Level 2	Supervisory level. This level allows, for example, parameter limits to be pre-set or programs to be edited or created. (Default Passcode = 2)
Level 3	Commissioning level. This level is intended for use when commissioning the instrument. It allows, for example, calibration offsets to be adjusted to match transducer and transmitter characteristics. (Default Passcode = 3)
View Config	It is possible also to read the configuration of the controller at any level but the configuration cannot be changed. (Passcode = 2604)
Config	Configuration of the controller allows you to set up the fundamental characteristics of the controller so that it can be made to match the requirements of the process. (Default Passcode = 4)

1.1.1 The Structure Of This Manual

This chapter provides an overview of the controller including the principle of the key handling and parameter navigation diagram.

Chapter 2 describes the principle of function blocks.

Chapter 3 explains how to wire function blocks using software wiring.

The remaining chapters provide the parameter tables with explanations of their meanings. These chapters follow the order in which the features appear in the pull out navigation at the end of this chapter.



1.2 WHAT IS 2604

The 2604 is a modular, fully configurable, high accuracy, high stability temperature and process controller which is available in a single, dual or three loop format.

It is supplied in accordance with an ordering code which can be found printed on a label on the side of the instrument case. A description of the order code is given in Appendix A of this guide and should be checked with that shown on the label.

It has a dual 7-segment display of process value and setpoint with a LCD panel for display of information and user defined messages.

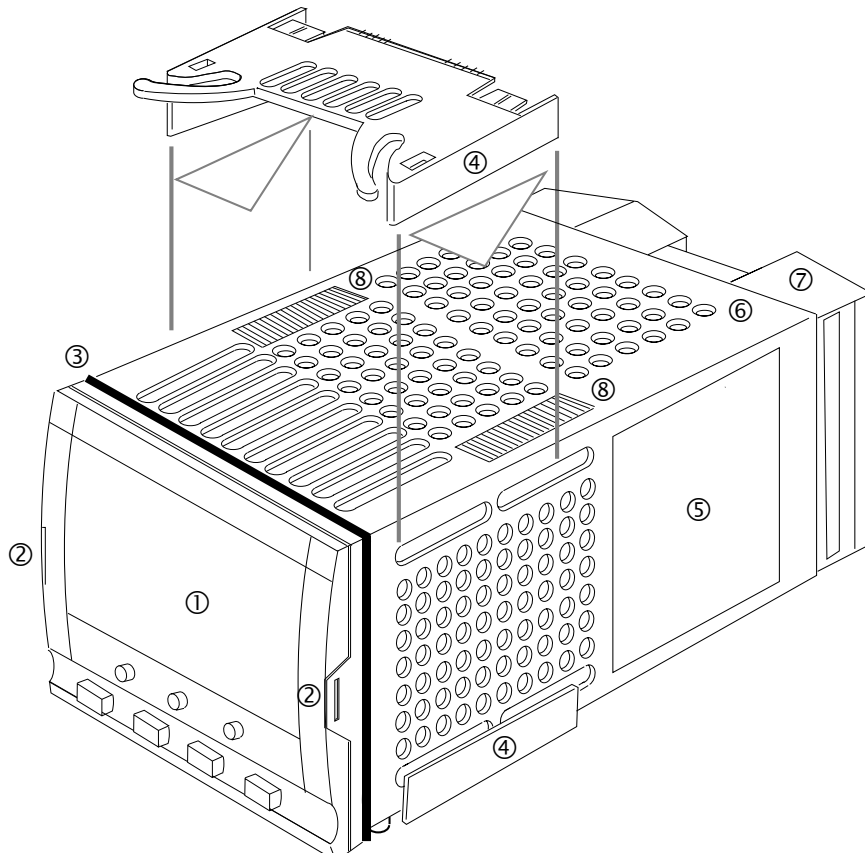
Figure 1-1: General View of 2604 Controller Display

Features include:

- Advanced ramp/dwell programmer with storage of up to 50 programs.
- Application specific controllers such as Carbon Potential, Temperature/Humidity and Melt Pressure
- A wide variety of inputs which can be configured, including thermocouples, Pt100 resistance thermometers and high level process inputs.
- Each loop can be defined to be PID, On/Off or motorised valve position and can control using a variety of strategies including single, cascade, override and ratio control.
- PID control outputs can be relay, logic, triac or dc with motorised valve position outputs being relay triac or logic.
- Auto tuning and PID gain scheduling are available to simplify commissioning and optimise the process

Configuration of the controller is explained in this manual. Configuration is achieved either via the front panel operator interface or by using 'iTools' - a configuration package which runs under the Windows 95, 98, 2000, ME, XP or NT (service pack 4 or later).

1.3 GENERAL VIEW OF 2604 CONTROLLER



KEY

- ① Display screen
- ② Latching ears
- ③ Panel sealing gasket
- ④ Panel retaining clips
- ⑤ Label
- ⑥ Sleeve
- ⑦ Terminal covers
- ⑧ Ratchets

Figure 1-2: General View of 2604 Controller

2. CHAPTER 2 INSTALLATION

This section has been re-produced from the 2604 User Handbook as a reference for installation and wiring of the controller.

2.1 MECHANICAL INSTALLATION

2.1.1 Positioning

The controller can be mounted vertically or on a sloping panel of maximum thickness 15mm (0.6in). Adequate access space must be available at the rear of the instrument panel for wiring and servicing purposes. The outline dimensions are shown in figure F-1.

Take care not to cover ventilation holes in the top, bottom and sides of the instrument.

Before proceeding please read Appendix B 'Safety and EMC Information'.

2.1.2 Outline dimensions Model 2604

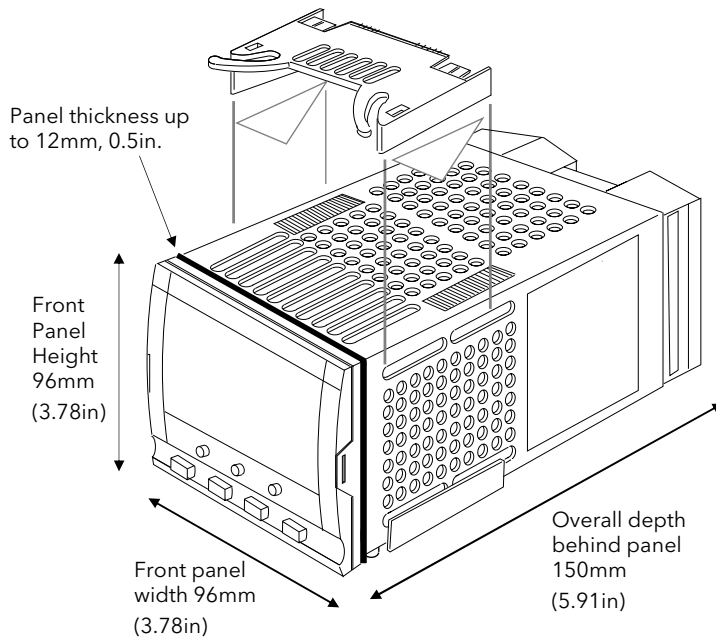


Figure 2-1: Outline Dimensions

2.1.3 Mounting the Controller

1. Prepare the panel cut-out to the size shown in Figure F-2. Ensure that there is sufficient spacing between instruments as shown by the minimum dimensions given in Figure F-2. Ensure also that the controller is not mounted close to any device which is likely to produce a significant amount of heat which may affect the performance of the controller.
2. Insert the controller through the panel cut-out.
3. Spring the upper and lower panel retaining clips into place. Secure the controller in position by holding it level and pushing both retaining clips forward.

Note:- If the retaining clips subsequently need removing, in order to extract the controller from the control panel, they can be unhooked from the side with either your fingers or a screwdriver.

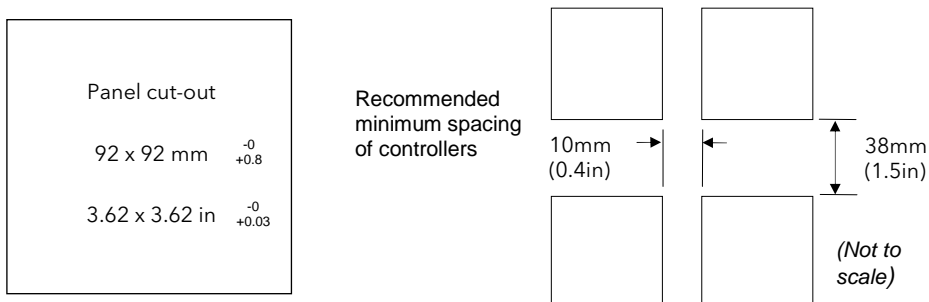


Figure 2-2: Panel Cut-out and Minimum Spacing Requirements

2.1.4 Unplugging and Plugging in the Controller

If required, the controller can be unplugged from its sleeve by easing the latching ears outwards and pulling the controller forward out of the sleeve. When plugging the controller back into its sleeve, ensure that the latching ears click into place.

It is recommended that the power to the controller is switched off when un-plugging or plugging the controller into its sleeve. This is to prevent premature wear on the controller connectors when current is flowing through them.

2.2 I/O MODULES

The 2604 controller has the facility to fit optional plug in modules. The connections for these modules are made to the inner three connector blocks as shown below.

The modules are:

- Communications modules.
- I/O modules

A list of available modules is given in **Error! Reference source not found.**

These modules are fitted simply by sliding them into the relevant position as shown below.

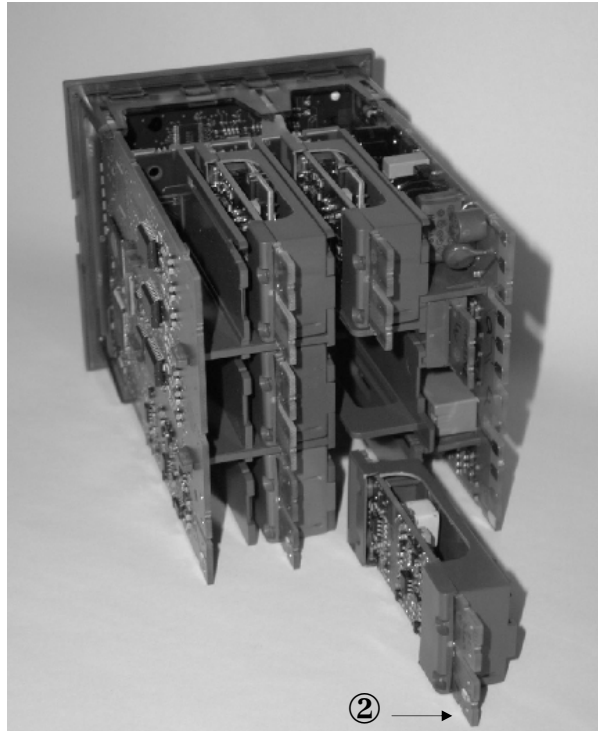




Figure 2-3: View of the Plug-in Modules

2.2.1 To Add or Change Modules

Should it be necessary to add, remove or change the position of modules the following procedure is recommended.

Remove the controller from its sleeve.

It is recommended that the controller is switched off before it is removed from its sleeve.

1. To remove the controller from its sleeve, push both latching ears ② (**Error! Reference source not found.**) outwards and ease the controller forwards from its sleeve. It should not be necessary to use any tools for this.
2. To remove a module it may be gripped by the rear terminals and pulled out from its location.
3. To fit a new module gently insert it into the required location ensuring that the raised section on the plastic cover of the module slides into the slot in the retaining housing.
4. Slide the controller back into its sleeve and turn power back on.
5. After a brief initialisation period, the message **!Module Changed** will appear on the display.
6. Press  and  together, as instructed, to acknowledge.
7. If the message **Bad Ident** is displayed this indicates that the wrong type of module has been installed, for example an unisolated logic output module from 2400 series.

2.3 WIRING

WARNING



You must ensure that the controller is correctly configured for your application. Incorrect configuration could result in damage to the process being controlled, and/or personal injury. It is your responsibility, as the installer, to ensure that the configuration is correct. The controller may either have been configured when ordered, or may need configuring now.

Before proceeding further, please read Appendix B, Safety and EMC information.

2.3.1 Electrical Connections

All electrical connections are made to the screw terminals at the rear of the controller. They accept wire sizes from 0.5 to 1.5 mm² (16 to 22 AWG) and should be tightened to a torque of 0.4Nm (3.5lbin). If you wish to use crimp connectors, the correct size is AMP part number 349262-1. The terminals are protected by a clear plastic hinged cover to prevent hands, or metal, making accidental contact with live wires.

2.3.2 Rear Terminal Layout

The rear terminal layout is shown in Figure F-3, which identifies terminal designations and their functions. Refer to the individual diagrams to wire the controller to your requirements.

The two outer terminal strips have fixed hardware for all versions of the instrument, as follows:-

- A Process Variable input which can be configured for:-
 - Thermocouple, RTD, Pyrometer, Voltage (e.g. 0-10Vdc) or Milliamp (e.g. 4-20mA) plus vacuum - log10
- Seven Digital I/O, configurable as input or output
 - Inputs are logic (-1 to 35Vdc) or contact closure, and can be configured for:- Manual, Remote, Run, Hold, Reset, etc,
 - Outputs are open collector requiring an external power supply, and can be configured as event, status time proportioning or valve position outputs.
- One digital input
- An I/O expander which allows additional digital I/O via an external unit, or an extra digital input
- A changeover relay which can be configured as an alarm or event output. It cannot be configured as a time proportioning output
- An analogue input for volts (e.g. 0-10Vdc) or Milliamp (e.g. 4-20mA) signals to a second PID loop, setpoint, etc,. (This input can be characterised to match a particular curve from a transmitter. It cannot accept thermocouple inputs directly)
- Power supply to the unit. The supply may be 100 - 230Vac 50 or 60 Hz,

The three central terminal strips are for optional plug in modules, as follows:-

- Terminals marked 2A to 2D are reserved for a Memory Module only. No connections should be made to these terminals
- Terminals marked HA to HF are connections for optional RS232, RS485, or RS422 communications modules
- Terminals marked JA to JF are connections for an optional slave communications module or second communications port used to communicate with other instruments

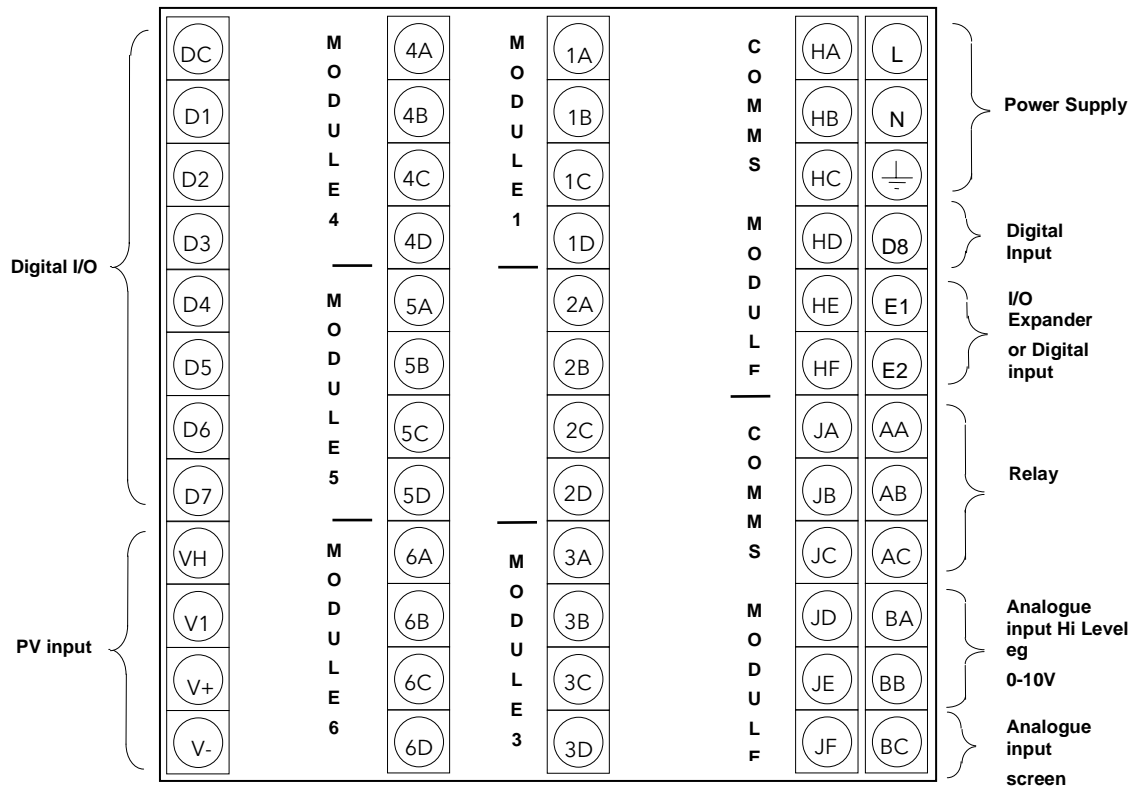
The modules fitted into the above two communications slots can be inter-changed

For a full list of available modules refer to the Ordering code - Appendix A and the Technical Specification - Appendix C.



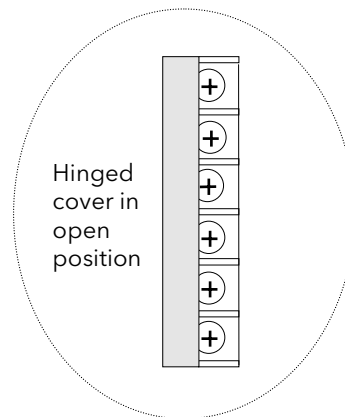
Warning:- Take care that mains supplies are connected only to the power supply terminals (100 to 230Vac only), the fixed relay terminals or to relay or triac modules. Under no circumstances should mains supplies be connected to any other terminals.

2.4 REAR TERMINALS



The functionality of the two outer rows of terminals is common to all instrument variants, as follows:-

PV input	VH, VI, V+, V-
Analogue input	BA, BB
I/O expander	E1, E2
Fixed changeover relay	AA, AB, AC
Digital I/O channels	D1 to D8 and DC
Power supply	L, N, Earth



* Terminals 2A, 2B, 2C, 2D must not be wired to.

Figure 2-4: Rear Terminal Connections

2.5 STANDARD CONNECTIONS

2.5.1 Power Supply Wiring

Controllers supplied with the VH Supply Voltage option are suitable for connection to a power supply of between 100 and 230Vac, $\pm 15\%$, 48 to 62 Hz.

Controllers supplied with the VL Supply Voltage option are suitable for connection to a power supply of 24Vac -15%, +10%, 48 to 62Hz or 24Vdc -15%, +20%.

It is the users responsibility to provide an external fuse or circuit breaker. Suitable fuses are :

For 100 to 230 volt supply Fuse type T (EN60127 time-lag type) rated at 1A ,250V

24 volt supply Fuse type T (EN60127 time-lag type) rated at 4A, 250V

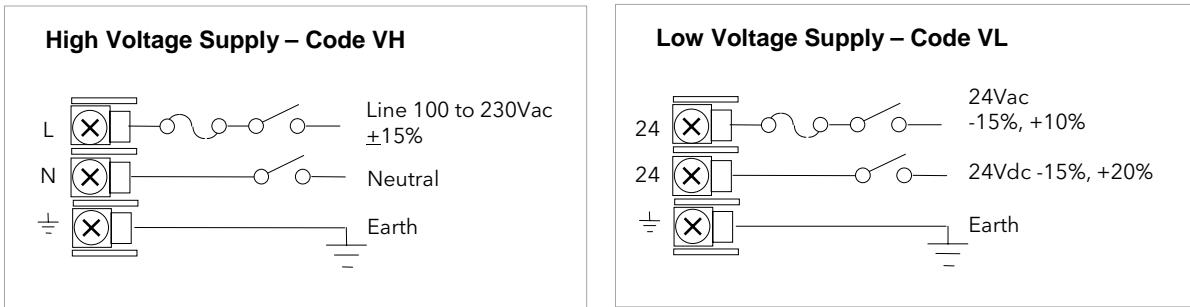


Figure 2-5: Supply Voltage Connections

2.5.2 Relay Output

A single changeover relay is provided as standard. It can be configured as a control output or an alarm or event output.

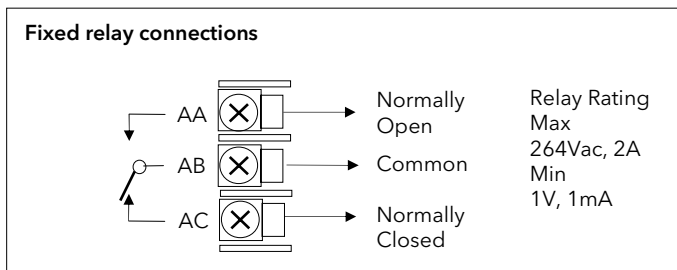
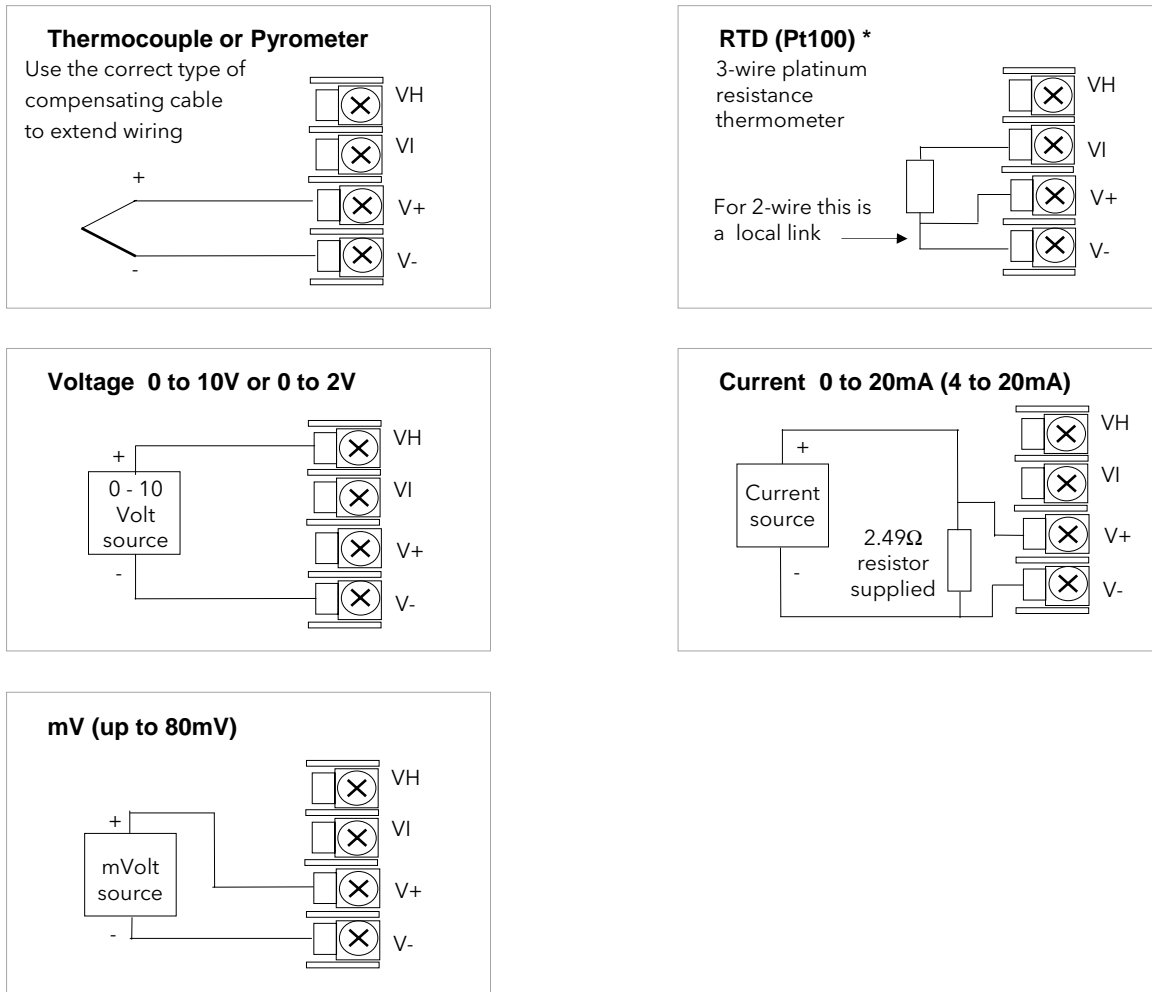


Figure 2-6: Wiring Connections For Fixed Relay Output

2.5.3 Sensor Input Connections

The fixed PV input can accept a range of sensors including Thermocouple, RTD (Pt100), Pyrometer, Voltage (e.g. 0-10Vdc) or Milliamp (e.g. 4-20mA) signals. These sensors are used to provide inputs to Control Loop 1.



* Note: This connection is shown for 2600 and 2700 series controllers. It is not the same as 2400 and 2200 series controllers.

Figure 2-7: Wiring Connections For PV Input

2.5.4 Analogue Input Connections

The analogue input is supplied as standard and is intended to accept 0 to 10 Vdc from a voltage source. A milli-amp current source can be used by connecting a 100Ω resistor across terminals BA and BB. This input can be used as a remote setpoint input, remote setpoint trim or as a high level PV input to a control loop. This input is not isolated from the digital IO.

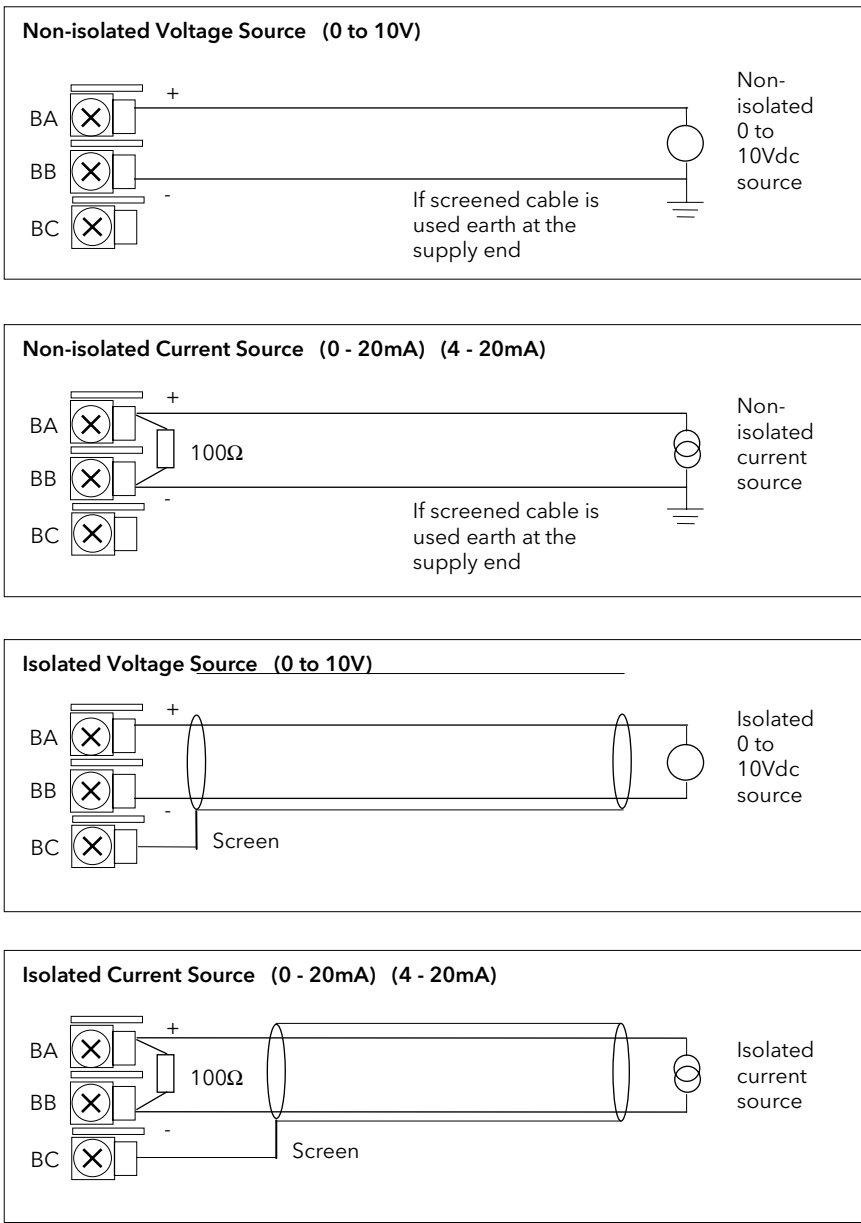


Figure 2-8: Wiring Connections For Analogue Input

2.5.5 I/O Expander (or Additional Digital Input)

An I/O expander (Model No 2000IO) can be used with the 2604 to allow the number of I/O points to be increased by a further 20 digital inputs and 20 digital outputs. Data transfer is performed serially via a two wire interface from instrument to expander.

If the expander unit is not required it is possible to use terminals E1 & E2 as a secondary digital input. These terminals are not part of the digital I/O terminals D1 to D8 and if used in this way connect a 2K2, ¼ W limiting resistor in series with the input, see Figure F-8.

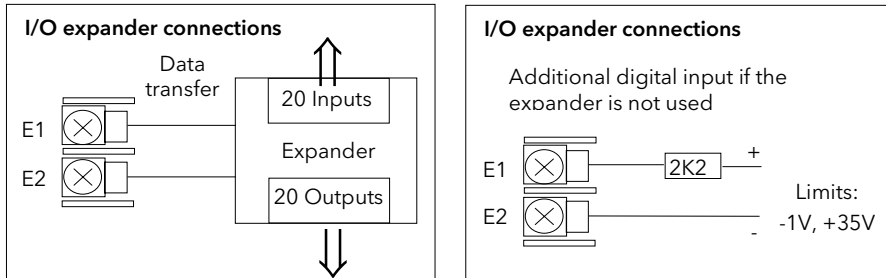


Figure 2-9: Wiring Connections for the I/O Expander

For details of the IO Expander refer to the Operating Instructions HA026893. The connections for this unit are reproduced below for convenience.

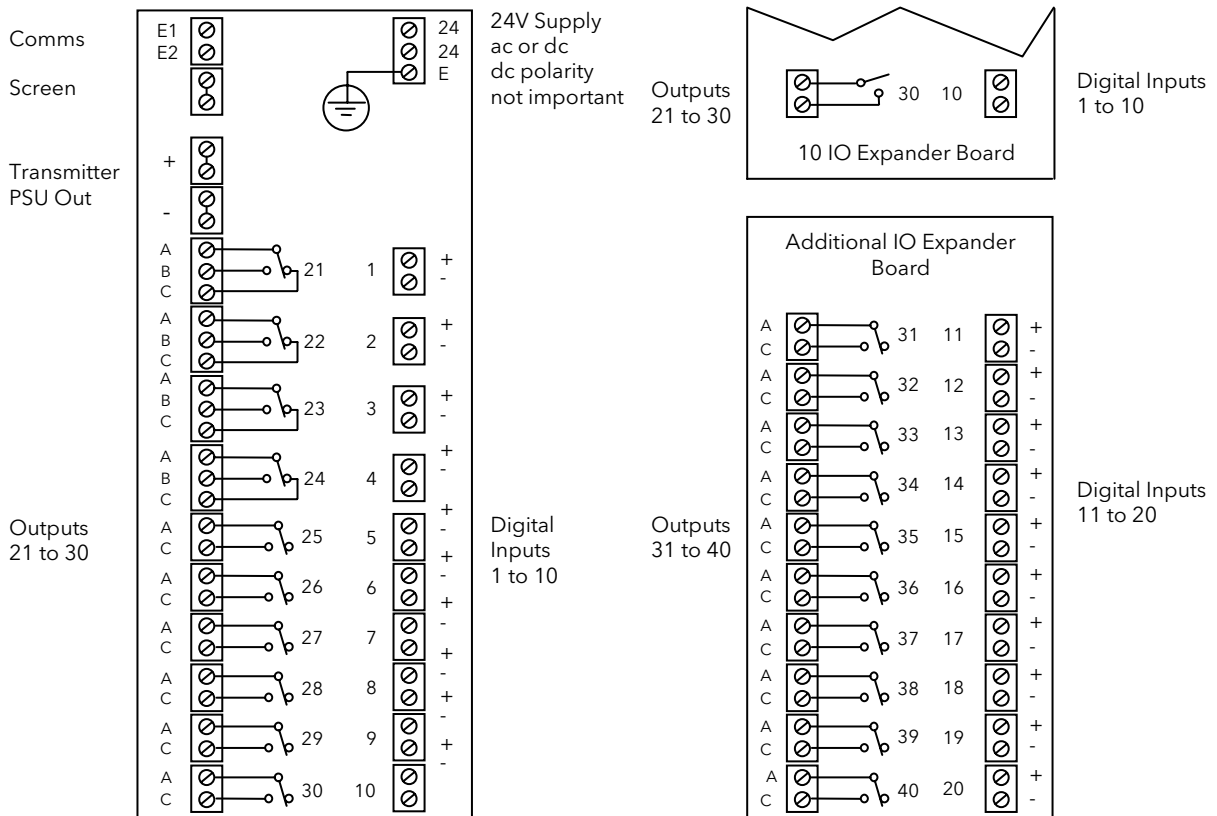


Figure 2-10: IO Expander Connections

2.5.6 Digital I/O

Eight digital I/O connections are provided as standard. They can be individually configured as:

1. Inputs Run, Hold, Reset, Auto/Manual, etc, - logic or contact closure.
2. Outputs Configurable as Control outputs, Programmer Events, Alarms, etc.

Digital IO is not isolated from instrument ground.

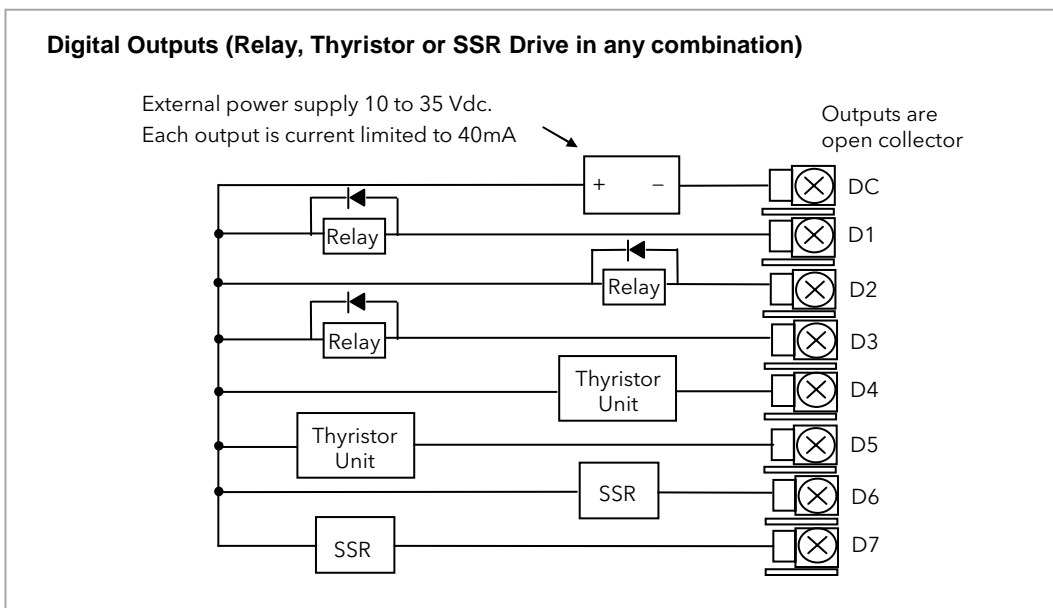
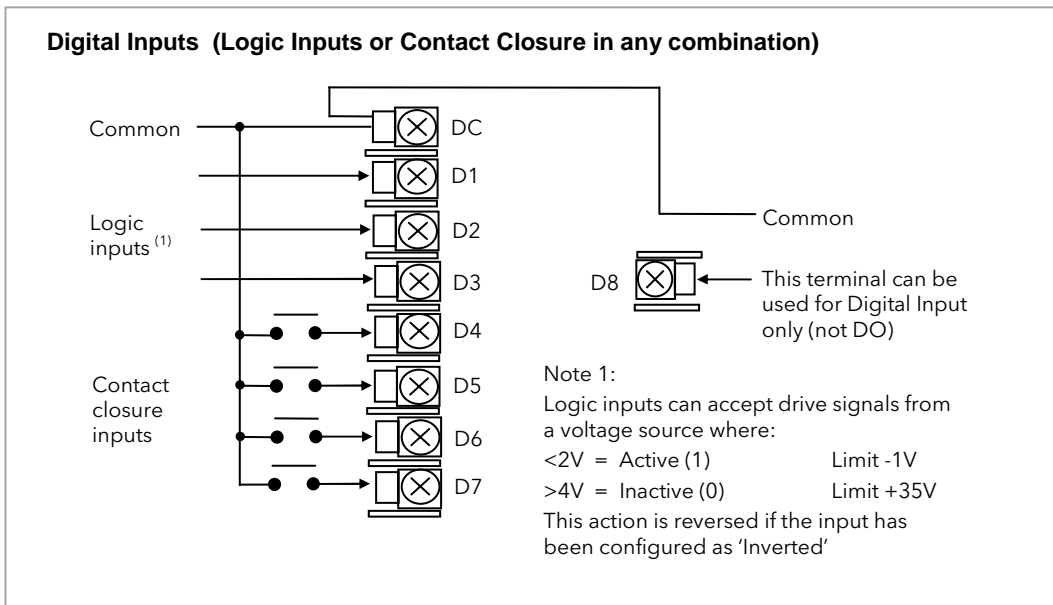


Figure 2-11: Wiring Connections for Digital I/O

2.6 OPTIONAL PLUG IN MODULE CONNECTIONS

2.6.1 Digital Communications Connections

Digital Communications modules can be fitted in two positions in the 2604 controller. The connections being available on HA to HF and JA to JF depending on the position in which the module is fitted. The two positions could be used, for example, to communicate with a configuration package, such as 'iTools', on one position and to a PC running a supervisory package on the second position.

The connections shown in the following diagrams show RS232, 2-wire RS485, 4-wire RS422 and master/slave comms to a second controller.

The diagrams show connections for 'bench top test' wiring. For a full description of the installation of a communications link, including line resistors, see Communications Handbook, Part No. HA026230, and EMC Installation Guide, part no. HA025464.

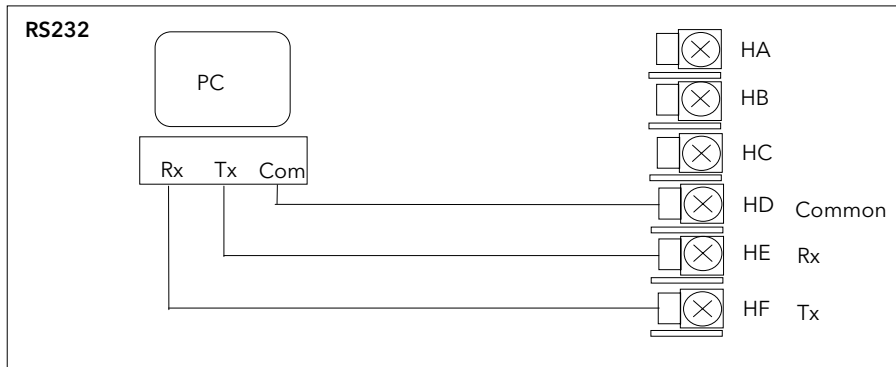


Figure 2-12: RS232 Communications Connections

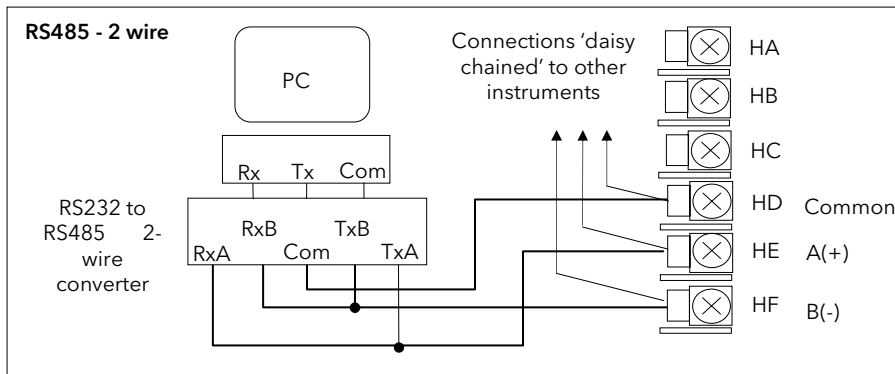


Figure 2-13: RS485 2-Wire Communications Connections

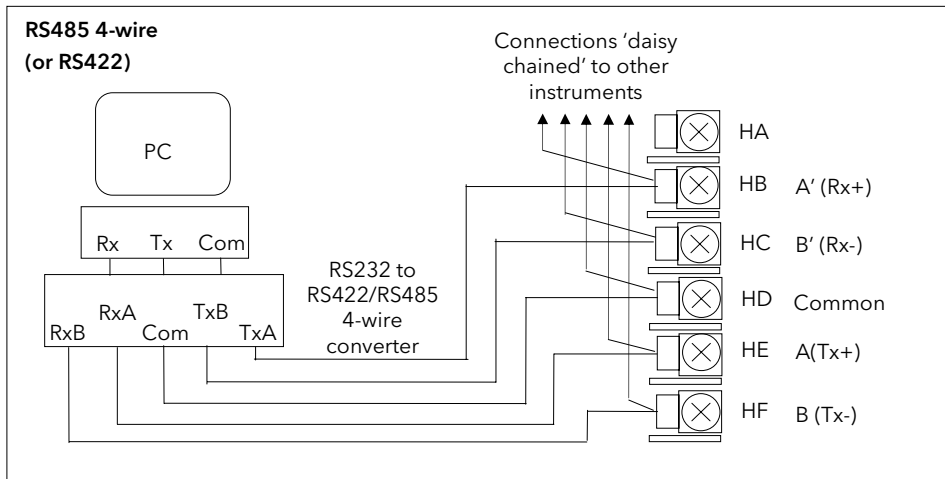


Figure 2-14: RS485 4-Wire Communications Connections

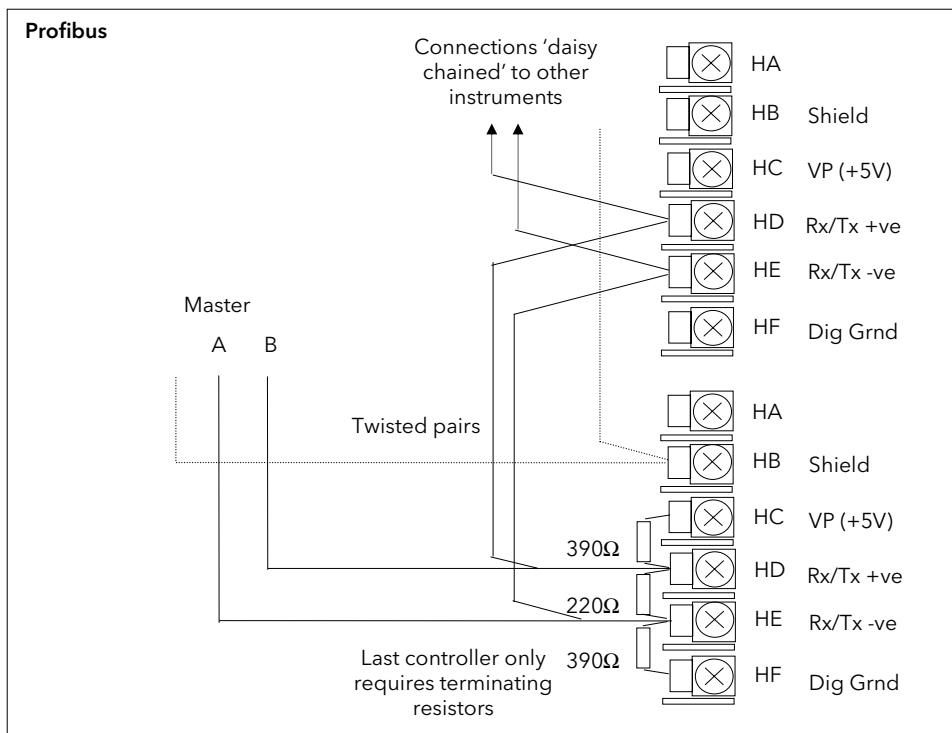


Figure 2-15: Profibus Wiring Connections

2.6.2 Devicenet Wiring

This section covers the DeviceNet digital communications option.

2.6.2.1 DeviceNet Terminal Functions

Terminal Reference	CAN Label	Color Chip	Description
HA	V+	Red	DeviceNet network power positive terminal. Connect the red wire of the DeviceNet cable here. If the DeviceNet network does not supply the power, connect to the positive terminal of an external 11-25 Vdc power supply.
HB	CAN_H	White	DeviceNet CAN_H data bus terminal. Connect the white wire of the DeviceNet cable here.
HC	SHIELD	None	Shield/Drain wire connection. Connect the DeviceNet cable shield here. To prevent ground loops, the DeviceNet network should be grounded in only one location.
HD	CAN_L	Blue	DeviceNet CAN_L data bus terminal. Connect the blue wire of the DeviceNet cable here.
HE	V-	Black	DeviceNet network power negative terminal. Connect the black wire of the DeviceNet cable here. If the DeviceNet network does not supply the power, connect to the negative terminal of an external 11-25 Vdc power supply.
HF			Connect to instrument earth

Note: Power taps are recommended to connect the DC power supply to the DeviceNet trunk line. Power taps include:



A Schottky Diode to connect the power supply V+ and allows for multiple power supplies to be connected.

2 fuses or circuit breakers to protect the bus from excessive current which could damage the cable and connectors.

The earth connection, HF, to be connected to the main supply earth terminal.

2.6.2.2 Wiring Interconnections for DeviceNet Communications

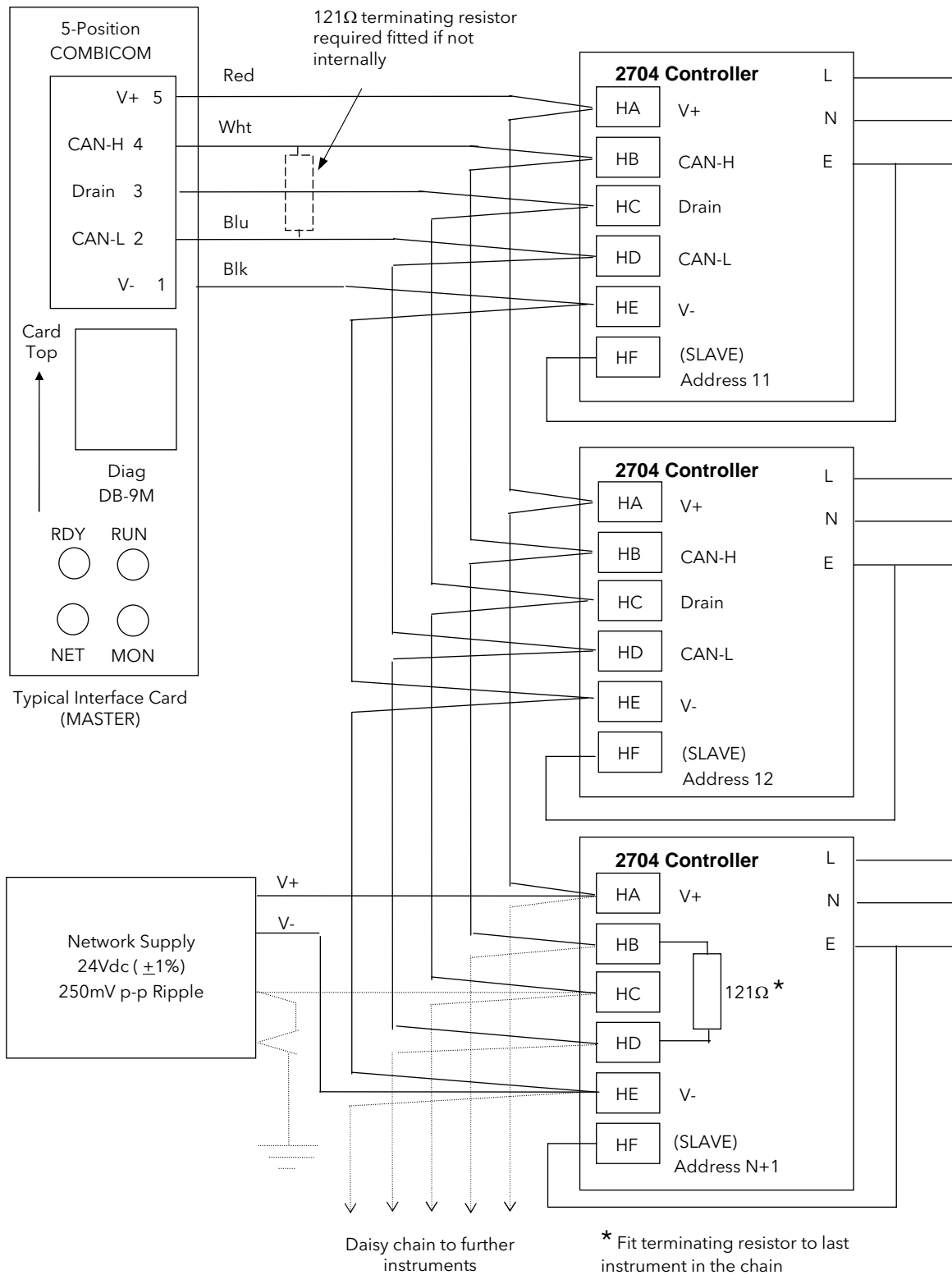
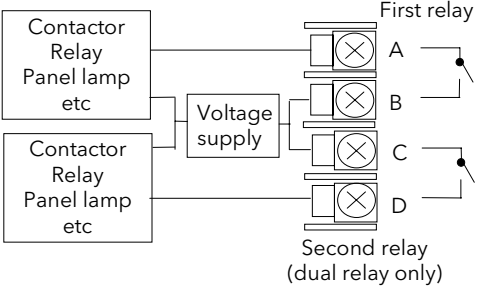
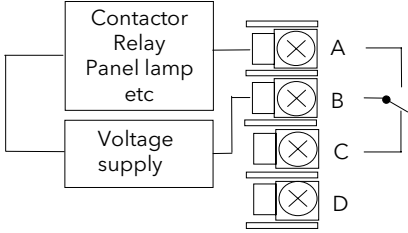
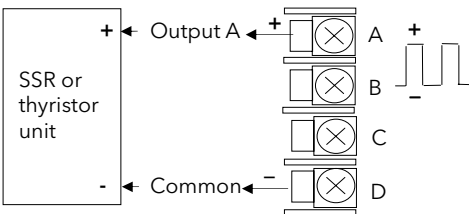
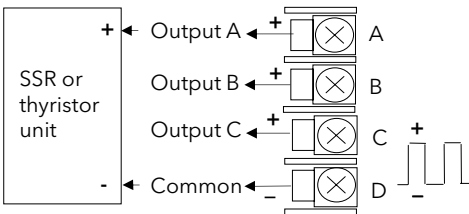


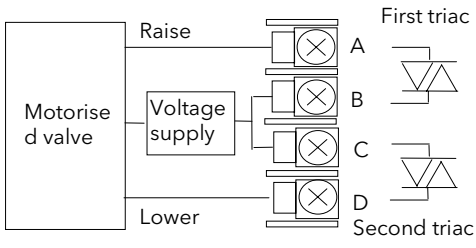
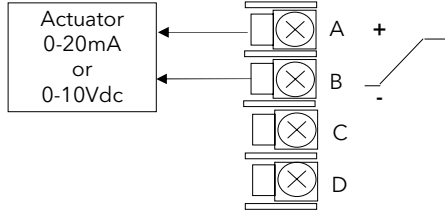
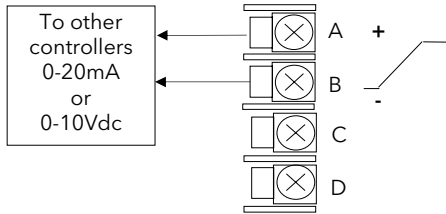
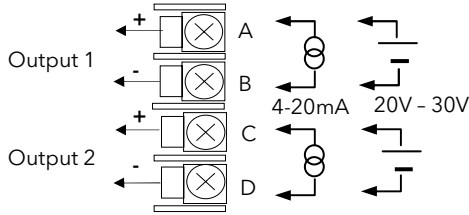
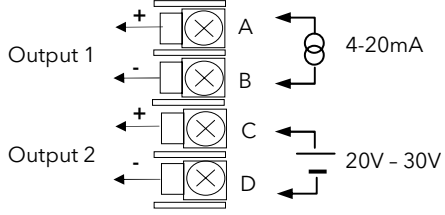
Figure 2-16: Devicenet Wiring

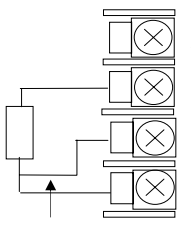
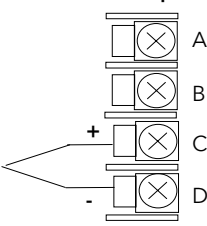
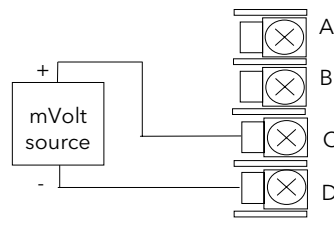
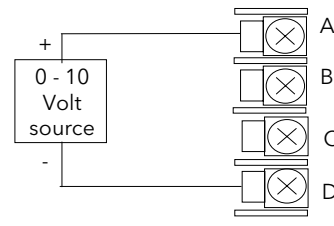
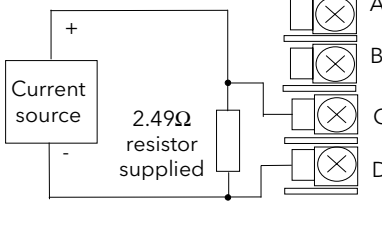
2.6.3 I/O Modules

The 2604 controller contains five positions in which 4-terminal I/O modules can be fitted. These positions are marked Module 1, Module 3, Module 4, Module 5, Module 6, in Figure F-3. Module 2 is reserved for the Memory Module which can only be fitted in this position. To find out which modules are fitted check the ordering code which is found on a label on the side of the instrument.

Any module, listed in this section, can be fitted in any position, except the PV input - limited to positions 3 and 6 only; and the Analogue Input module - cannot be fitted in slot 5. Care should be taken, therefore, to ensure that modules are fitted as expected from the order code. The instrument can be interrogated in 'View Config' level to locate the positions in which the modules are fitted. See Chapter 4, Access Levels. If modules have been added, removed or changed it is recommended that this is recorded on the instrument code label.

I/O Module	Typical usage	H/W Code	Connections and examples of use
<p>Note: The order code and terminal number is pre-fixed by the module number. Module 1 is connected to terminals 1A, 1B, 1C, 1D; module 3 to 3A, 3B, 3C, 3D, etc.</p>			
<p>Relay (2 pin) and Dual Relay max 264Vac, 2A, min 12V, 100mA</p>	<p>Heating, cooling, alarm, program event, valve raise, valve lower</p>	<p>R2 and RR</p>	
<p>Change Over Relay max 264Vac, 2A, min 12V, 10mA</p>	<p>Heating, cooling, alarm, program event, valve raise, valve lower</p>	<p>R4</p>	
<p>Isolated Single Logic Output 18Vdc at 24mA max</p>	<p>Heating, Cooling, Program events</p>	<p>LO</p>	
<p>Triple Logic Output (18Vdc at 8mA max. per channel)</p>	<p>Heating, cooling, program events</p>	<p>TP</p>	

I/O Module	Typical usage	H/W Code	Connections and examples of use
<p>Triac and Dual Triac</p> <p>(0.7A, 30 to 264Vac combined rating)</p>	<p>Heating, cooling, valve raise, valve lower</p>	<p>T2 and TT</p>	 <p>Note: Dual relay modules may be used in place of dual triac.</p> <p>Note:- The combined current rating for the two triacs must not exceed 0.7A.</p>
<p>DC Control</p> <p>(10Vdc, 20mA max)</p>	<p>Heating, cooling</p> <p>e.g. to a 4-20mA process actuator</p>	<p>D4</p>	
<p>DC Re-transmission</p> <p>(10Vdc, 20mA max)</p>	<p>Logging of PV, SP, output power, etc.,</p> <p>(0 to 10Vdc, or 0 to 20mA)</p>	<p>D6</p>	
<p>Dual DC Output</p> <p>(each channel can be 4-20mA or 24Vdc power supply)</p>	<p>Control output 12 bit resolution</p> <p>Can only be fitted in slots 1,4 or 5</p>	<p>DO</p>	
<p>High Resolution DC Output</p> <p>(one 15 bit 4-20mA plus one 24V power supply)</p>	<p>Retransmission in 'feedback mode'</p> <p>Can only be fitted in slots 1,4 or 5</p>	<p>HR</p>	

I/O Module	Typical usage	Order Code	Connections and examples of use
<p>PV Input (Modules 3 & 6 only)</p> <p>and</p> <p>Analogue Input (Modules 1, 3, 4 & 6 only)</p>	<p>Second or third PV input</p> <p>mV, V, mA, TC, RTD (Pt100) Zirconia probe</p> <p>Second or third PV input</p> <p>mV, mA, TC, RTD (Pt100)</p>	<p>PV</p> <p>AM</p>	<div style="display: flex; justify-content: space-around;"> <div style="text-align: center;"> <p>3-wire RTD</p>  </div> <div style="text-align: center;"> <p>Thermocouple</p>  </div> </div> <p>For 2-wire this is a local link</p> <div style="text-align: center;"> <p>AM (up to 100mV)</p>  </div> <div style="text-align: center;"> <p>Voltage 0 to 10V or 0 to 2V</p>  </div> <div style="text-align: center;"> <p>Current 0 to 20mA (4 to 20mA)</p>  </div>
<p>Triple Logic Input</p>	<p>Events</p> <p>e.g. Program Run, Reset, Hold</p>	<p>TL</p>	<p>Logic inputs</p> <p>Input 1 → [X] A</p> <p>Input 2 → [X] B</p> <p>Input 3 → [X] C</p> <p>Common → [X] D</p> <p><5V OFF >10.8V ON</p> <p>Limits: -3V, +30V</p>
<p>Triple Contact Input</p>	<p>Events</p> <p>e.g. Program Run, Reset, Hold</p>	<p>TK</p>	<p>External Switches or Relays</p> <p>Input 1 → [X] A</p> <p>Input 2 → [X] B</p> <p>Input 3 → [X] C</p> <p>Common → [X] D</p> <p>Contact inputs</p> <p><100Ω ON >28KΩ OFF</p>

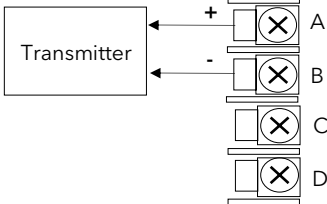
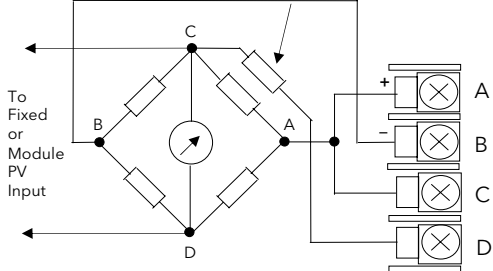
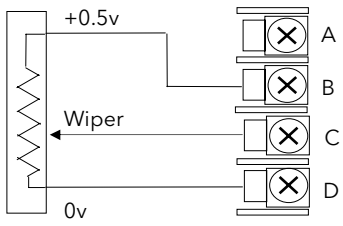
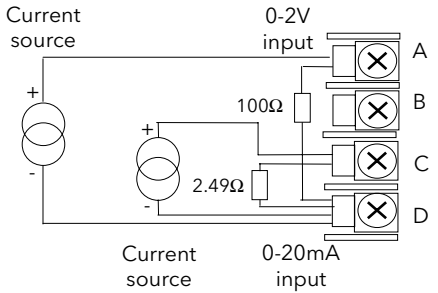
I/O Module	Typical usage	Order Code	Connections and examples of use
<p>24V Transmitter Supply</p> <p>(20mA)</p>	<p>To power an external transmitter</p>	<p>MS</p>	
<p>Transducer Power Supply</p>	<p>Provide 5V or 10Vdc to power Strain Gauge Transducer + Shunt Contact</p>	<p>G3 or G5</p>	<p>External calibration resistor (may be fitted in transducer).</p>  <p>Note: To minimise noise pick up it is recommended that screened cables are used for strain gauge power supply connections.</p>
<p>Potentiometer Input</p> <p>(100Ω to 15KΩ)</p>	<p>Motorised valve position feedback</p> <p>Remote SP</p>	<p>VU</p>	
<p>Dual PV Input</p> <p>(Modules 3 & 6 only)</p>	<p>To accept two inputs from a high level and a low level source. The two inputs are not isolated from each other.</p>	<p>DP</p>	 <p>The common connections to terminal D must be returned separately to D as shown in the dual current example above.</p>

Figure 2-17: Wiring Connections for IO Modules

2.7 TO CONNECT ZIRCONIA (DUAL SIGNAL) PROBE

A dual signal probe, such as a Zirconia probe, will normally be connected to a Dual PV Input module (Code DP). The module presents two channels, A and C, where A is the voltage input and C is the mV, thermocouple, RTD or mA input.

Example 1 shown below uses the Dual PV Input module with both channels configured. In this configuration the module runs at 4.5Hz. The two channels are un-isolated from one-another but isolated from the rest of the instrument.

Example 2 uses two modules. The modules can either be two PV Input modules (code PV) or a Dual PV Input module (code DP) with Channel C configured as 'None' plus a PV Input module. This combination runs at 9Hz and may be used if the loop is unusually fast.

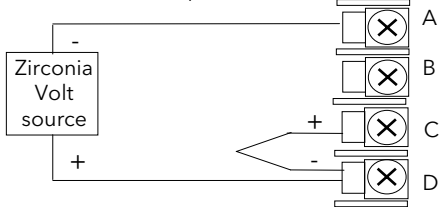
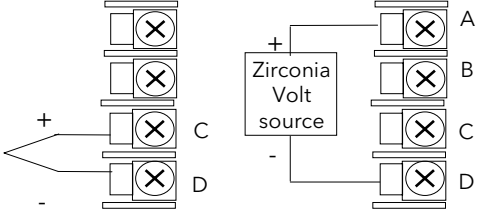
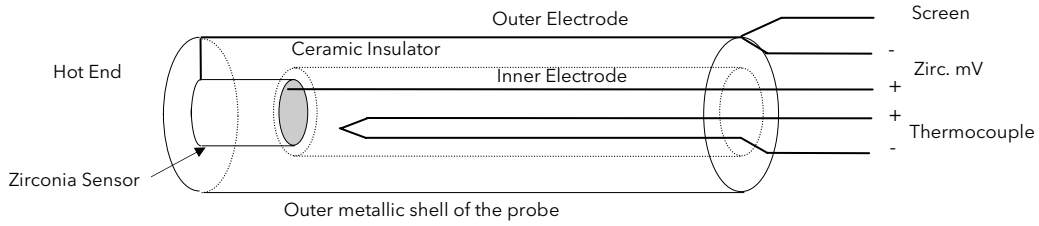
I/O Module	Typical usage	Order Code	Connections and examples of use
Dual PV Input	Zirconia probe	DP	<p>Example 1:- Using the Dual PV Input Module. Channel C is shown configured for thermocouple. The temperature sensor of a zirconia probe is connected to this input, terminals C & D. The Volt Source is connected to the A channel, terminals A & D.</p>  <p>Note: The +ve of the volt source must be connected to the -ve of the thermocouple.</p>
Two PV Input Modules	PV		<p>Example 2:- Using Two Modules The temperature sensor of the zirconia probe can be connected to the precision PV input of one I/O module, connections C & D, with the Volt Source connected to the second module, terminals A & D.</p> 

Figure 2-18: Wiring Connections for Zirconia Probe

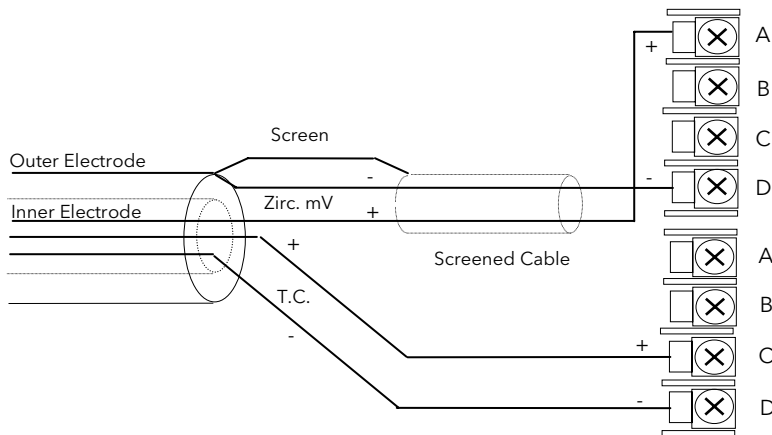
2.7.1 Zirconia Probe Screening

2.7.1.1 Zirconia Carbon Probe Construction



2.7.1.2 Screening connections when two modules are used

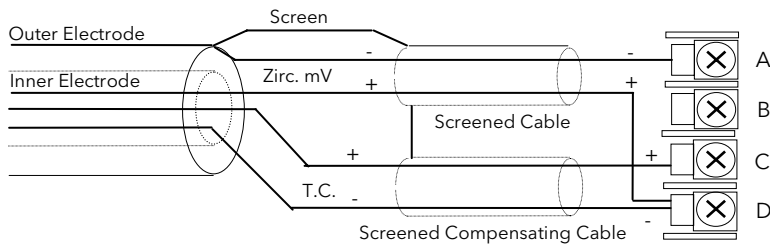
The zirconia sensor wires should be screened and connected to the outer shell of the probe if it is situated in an area of high interference.



2.7.1.3 Screening connections when a dual input module is used

Both the thermocouple and the zirconia sensor wires must be screened and connected to the outer shell of the probe if it is situated in an area of high interference.

Note the reverse connection of the zirconia sensor .



2.8 OPERATOR INTERFACE - OVERVIEW

The front panel of the 2604 consists of two 5 digit numeric readouts, one alpha numeric readout, eight LED status indicators and seven operator push-buttons. See below

- The upper numeric readout normally indicates the current process value from the plant.
- The centre readout is slightly smaller than the upper display and normally shows the setpoint.
- The lower readout is an alpha numeric LCD display which provides access to instrument operating and configuration parameters.
- The eight LED status indicators are illuminated to show controller operating mode such as a loop view, auto/manual or programmer run/hold.
- The seven operator buttons allow adjustments to be made to the controller.

2.8.1 Readouts and Indicators

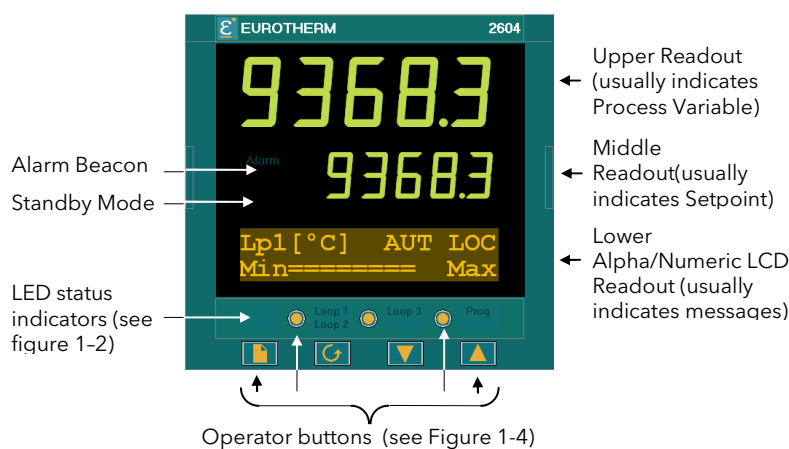


Figure 2-19: Operator Interface

[Units] If units have been selected in configuration level they will be displayed in the lower readout.

The choices are:-

°C/°F/°K

V, mV, A, mA

PH

mmHg, psi, bar, mbar, mmWg, inWg, inWW, PSIG

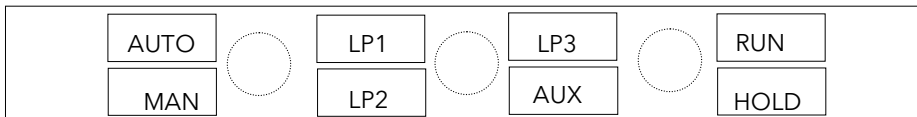
Ohms

%, %RH, %O2, %CO2, %CP,

PPM

Custom units are also possible

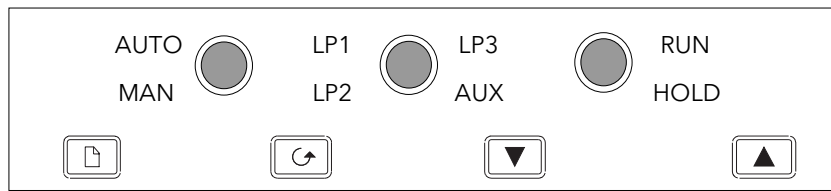
2.8.2 LED Status Indicators



Indicator	Function
AUTO	The selected loop is in automatic (closed loop) control
MAN	The selected loop is in manual (open loop) control
LP1	Indicates which control loop is selected
LP2	
LP3	
AUX	Indicates that the selected loop has a second control function. For example, if a loop is configured as cascade or override then a second press of the loop button will cause the AUX indicator to illuminate together with the loop indicator. If the loop is configured as Ratio this display is also used to show the ratio parameters even though ratio only uses one control loop.
RUN	Indicates a program is activated
HOLD	Indicates a program is held at its current levels
ALARM BEACON	This is a red LED which will flash when any new alarm occurs. It will be accompanied by a message displayed on the lower readout. The beacon will be permanently lit when an alarm is acknowledged but is still present.
STANDBY BEACON	This is a green LED which will be lit when the controller is in Standby mode. When the controller is in standby mode all interfaces to the plant are switched to a rest condition. For example, all control outputs = 0. When this beacon is lit the controller is no longer controlling the process. This beacon will be lit when:- The controller is in configuration mode Standby mode has been selected through the user interface or via an external digital input During the first few seconds after start up

Figure 2-20: Status Indicators

2.8.3 Operator Buttons











	<p>Auto/Manual button</p>	<p>The Auto/Manual button only operates from the loop view. When pressed, this toggles between automatic and manual mode:</p> <ul style="list-style-type: none"> • If the controller is in automatic mode the AUTO light will be lit. • If the controller is in manual mode, the MAN light will be lit.
	<p>Loop select button</p>	<p>Repeat pressing to select:- Loop1 ▶ Loop2 ▶ Loop 3 ▶ Back to Loop1 If a loop is cascade, ratio or override the AUX indicator will illuminate as well as the loop indicator.</p> <p>When this loop overview is selected pressing  will scroll through up to 10 parameters. These parameters can be chosen by the user in configuration level.</p>
	<p>Run/Hold button</p>	<ul style="list-style-type: none"> • Press once to start a program (RUN light on.) • Press again to hold a program (HOLD light on) • Press again to cancel hold and continue running (HOLD light off and RUN light ON) • Press and hold in for two seconds to reset a program (RUN and HOLD lights off) <p>The RUN light will flash at the end of a program. The HOLD light will flash during holdback.</p>
<p>The above three buttons (Function Keys 1 to 3) can be disabled, see Section 5.2.3.</p>		
	<p>Page button</p>	<p>Press to select a new list of parameters.</p>
	<p>Scroll button</p>	<p>Press to select a new parameter in a list.</p>
	<p>Down button</p>	<p>Press to decrease a parameter value.</p>
	<p>Up button</p>	<p>Press to increase a parameter value.</p>

Figure 2-21: Operator Buttons

2.9 PARAMETERS AND HOW TO ACCESS THEM

Parameters are settings, within the controller, which determine how the controller will operate. They are accessed using the lower alpha-numeric display and can be changed by the user to suit the process. Selected parameters may be protected under different security access levels.

Examples of parameters are:-

Values - such as setpoints, alarm trip levels, high and low limits, etc.,
or

States - such as auto/manual, on/off, etc. These are often referred to as enumerated values.

2.9.1 Pages

The parameters are organised into different pages. A page shows information such as page headers, parameter names and parameter values.

Parameters are grouped in accordance with the function they perform. Each group is given a '**Page Header**' which is a generic description of the parameter group. Examples are 'The Alarm Page', 'The Programmer Page', etc,. A complete list of pages are shown in the navigation diagram, Section 1.14.

The 2604 contains a set of default pages for most applications. It is possible to configure different start up pages as the Home page, but the principle of navigation is the same as the default pages.

Note:-

A page only appears on the controller if the function has been ordered and has been enabled in Configuration mode. For example, if a programmer is not configured the RUN page and the EDIT PROGRAM pages will not be displayed.

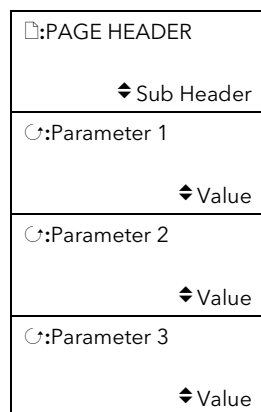


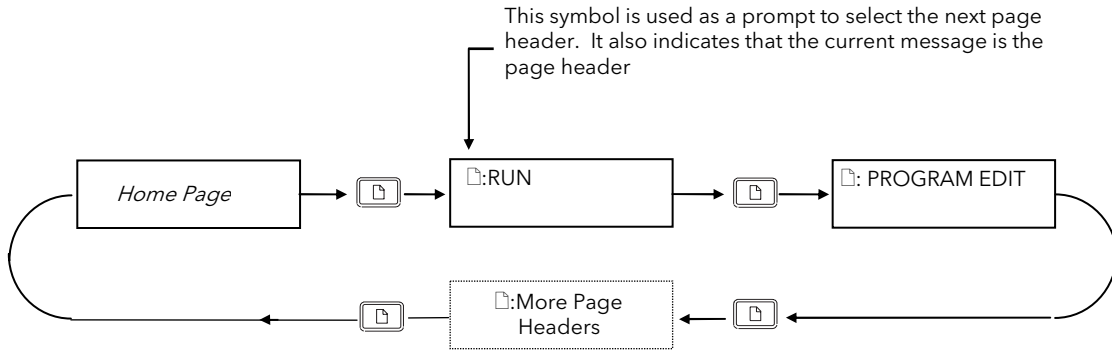


Figure 2-22: Page Concept

2.9.2 To Step Through Page Headers

Press  - (The Page Button).

At each press the first line of the alpha-numeric display will change to the name of the **page header**. This is a continuous list which will eventually return to the starting point, as shown below. If the page button, , is held down continuously the pages auto advance.






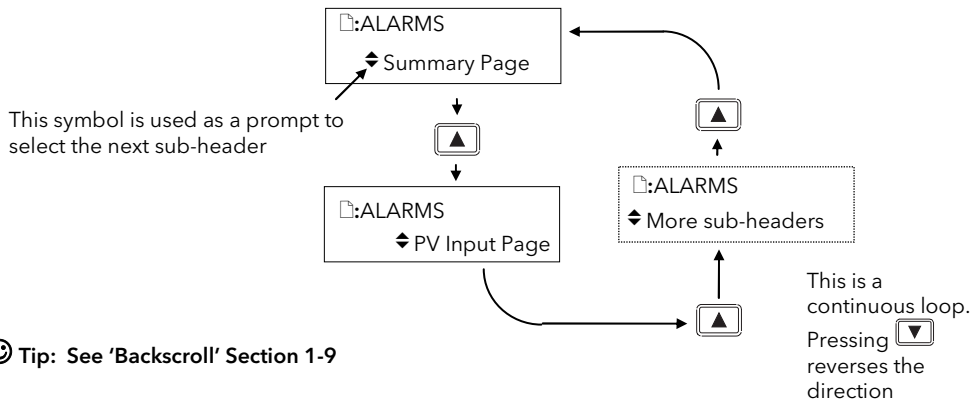
☺ Tip: See 'Backpage' Section 1-8

Figure 2-23: Stepping Through Page Headers

2.9.3 Sub-headers

The page header shown in Figure 1-11 contains sub-headers.. The sub-header appears in the lower right hand corner of the alpha-numeric display.

The sub-header can be changed using the  or  buttons, as prompted by the  symbol. This is a continuous list which will return to the first sub-header.




☺ Tip: See 'Backscroll' Section 1-9

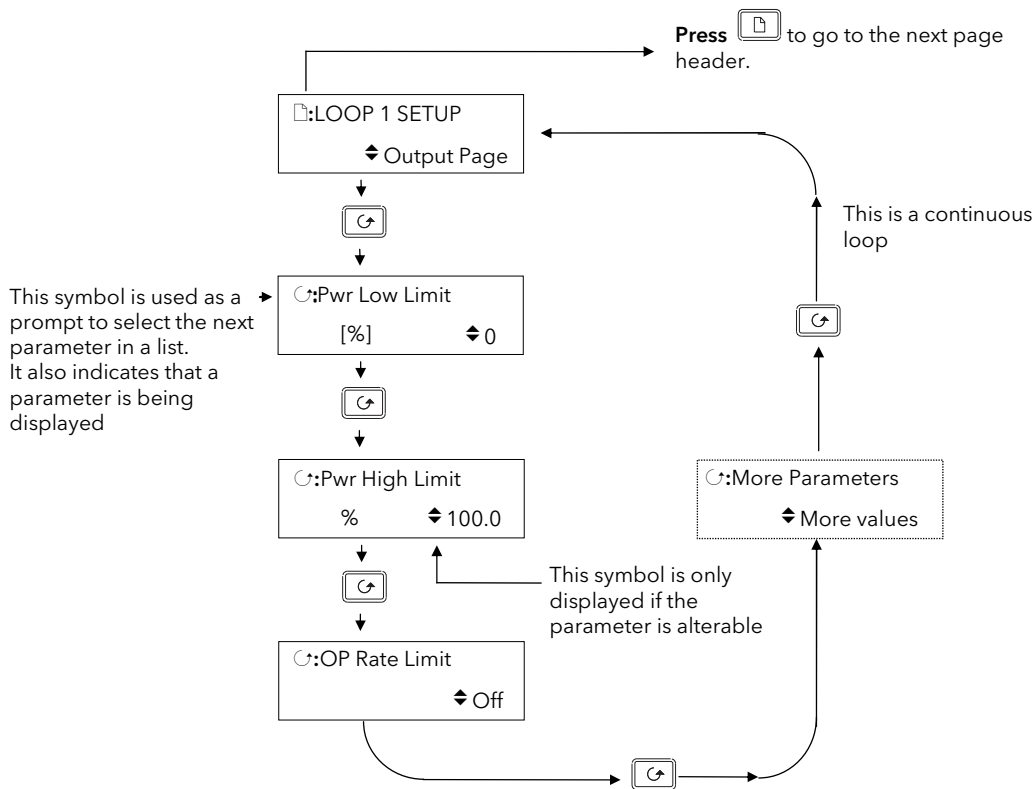
Figure 2-24: Sub-header Selection

2.9.4 To Step Through Parameters

When the page header (and sub-header) which contains the required parameter has been selected :-

Press  - (The Scroll Button)

This will access the first parameter on the page. At each subsequent press the next parameter in the list is displayed. This is a continuous list which will eventually return to the list header. If the scroll button, , is held down the parameters auto advance.



😊 Tip: See 'Backscroll' Section 1-9



Figure 2-25: Parameter Selection

😊 Tip:- To return to the Page Header at any time press .

2.9.5 To Change Parameter Values

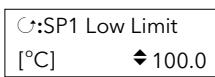
When the required parameter has been selected its value is shown in the lower part of the alpha-numeric readout.



To change a parameter value press  or  - (The Raise or Lower Buttons)

If an attempt is made to change a read only parameter, the parameter value will be replaced by ----- as long as the  or  buttons are held. For many parameters an upper and lower limit can be set. When changing a parameter value its new value must be within these limits.

Parameter values can be displayed in different ways depending upon the parameter type. Figure 1-13 below shows the different types of parameter and how their values are changed.

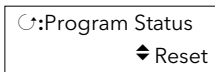
1. Numerical Values





Press  to increase the value
 Press  to decrease the value
 (◊ shown only if parameter alterable)

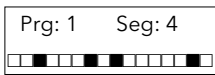
Note:
 Units are displayed automatically if applicable




2. Enumerated Values



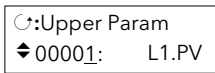
Press  to show next state
 Press  to show previous state



3. Digital Values (e.g. programmer event outputs)




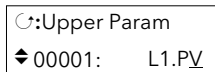
Press  to step along the values. The selected value flashes.
 Press  or  to turn the value on [■] or off [□]
 Tip: See 'Backscroll' Section 1.8 to step back



4. Parameter Addresses



Press  or  to change the **Parameter address**. A cursor flashes under the parameter address indicating that it can be changed.
 The parameter name for that address (if it exists) is shown in the lower right of the readout.

Press  to change from parameter address to parameter name



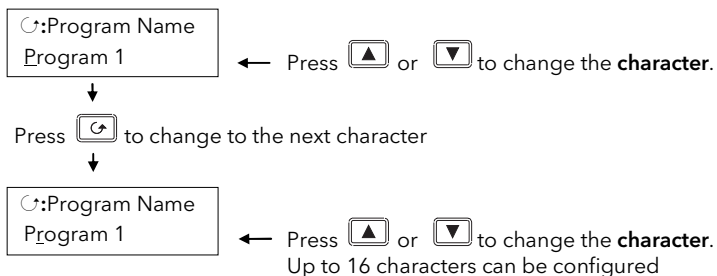
Press  or  to change the **parameter name**. A cursor flashes under the parameter name indicating that it can be changed.

Note:- The parameter addresses are only available in configuration level, but are included here to illustrate the principle of operation.

Figure 2-26: Changing a Parameter Value

5. Text (User definable)

The first character alternates between the character and _ indicating that it can be changed



Tip: See 'Backscroll' Section 1.8 to if you need to re-enter a previously entered character.

6. Time

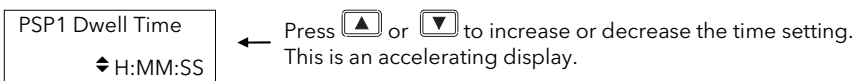


Figure 2-27: Changing a Parameter Value (continued)

2.9.6 Confirmation Mechanism




When the [Up] or [Down] key is released, the display will blink after a period of 1.5 seconds, indicating that the new parameter value has been accepted. If any other key is pressed during the 1.5 second period the parameter value is accepted immediately.

There are exceptions for specific parameters. Examples of these are:-

Output Power adjustment when in Manual mode. The value is written continuously as the value is changed.




Alarm Acknowledge. If the Alarm Acknowledge is changed from 'No' to 'Acknowledge' a confirmation message appears. Press [Enter] key to confirm the change. If no key is pressed for 10 seconds the value is restored to its previous value.

2.10 BACKPAGE

When stepping through list headers, a backpage short cut is provided by holding down  and pressing . Each press of  will step back one position of the list header in a continuous loop.



This function is provided as a short cut and is not necessary to navigate through the pages.

2.11 BACKSCROLL

When stepping through parameters in a list, a backscroll short cut is provided by holding down  and pressing . Each press of  will step back to the previous parameter, until the page header is reached.

This function is provided as a short cut and is not necessary to navigate through the parameters.




2.12 JUMP TO HOME DISPLAY

Press  and  together to return the display to the configured HOME screen.

2.13 INVALID KEY ACTIONS

At any time some state transitions may be invalid, due, for example, to contention with digital inputs or to the current operating state of the instrument.

Examples are:-

1. Digital inputs have priority over the operator buttons.
2. If a parameter value cannot be changed the  prompt is not shown
3. If the  or  button is pressed for a read only parameter a number of dashes, ----, is displayed.

2.14 PARAMETER TABLES

Subsequent chapters in this manual refer to parameter tables. These tables provide the full list of parameters available in 'Config' level in a particular page. The table below is an example.

- Column 1 gives the name of the parameter as it appears on the display.
- Column 2 is a description and possible usage of the parameter
- Column 3 is the range of values which can be set. . This may be a numerical value, eg -n to +n, or the condition (enumeration) of a parameter, eg the parameter 'Program Status' has enumerations 'Run', 'Hold', 'Reset'.
- Column 4 is the default value (if applicable) of the parameter set during manufacture
- Column 5 is the access level required to change the parameter value.
 - L1 means that the value is only shown in Level 1
 - L2 means that the value is only shown in Level 1 and Level 2
 - L3 means that the value is always available in the instrument operating mode Conf means Configuration Level
 - R/O is Read Only
 - Access Levels are described in Chapter 4.

Table Number: Description of the page				Page Header
1	2	3	4	5
Parameter Name	Parameter Description	Value	Default	Access Level
Program Number	The number of the selected program			L3
Segment Number	The currently running segment number			L3
PSP1 Type	Program Setpoint 1 type			L3
PSP1 Working SP	Program Setpoint 1 working setpoint			L3
PSP1 Target	Program Setpoint 1 target setpoint			L3
PSP1 Dwell Time	Program Setpoint 1 dwell time			L3
This is a continuous loop which returns to the list header				

Notes:-

1. A parameter only appears if it is relevant to the configuration of the controller. For example, a programmer configured as Time to Target will not display the Rate parameter.
2. Throughout this handbook parameter names shown in *italics* are customisable by the user when in configuration access level. The name of the parameter may vary, therefore, from instrument to instrument.

2.15 PARAMETER AVAILABILITY AND ALTERABILITY

A parameter which appears on a page is described as available. Parameters are not available if they are not appropriate for a particular configuration or instrument status. For example, relative cool gain does not appear in a heat only controller, and integral time does not appear in an On/Off controller.

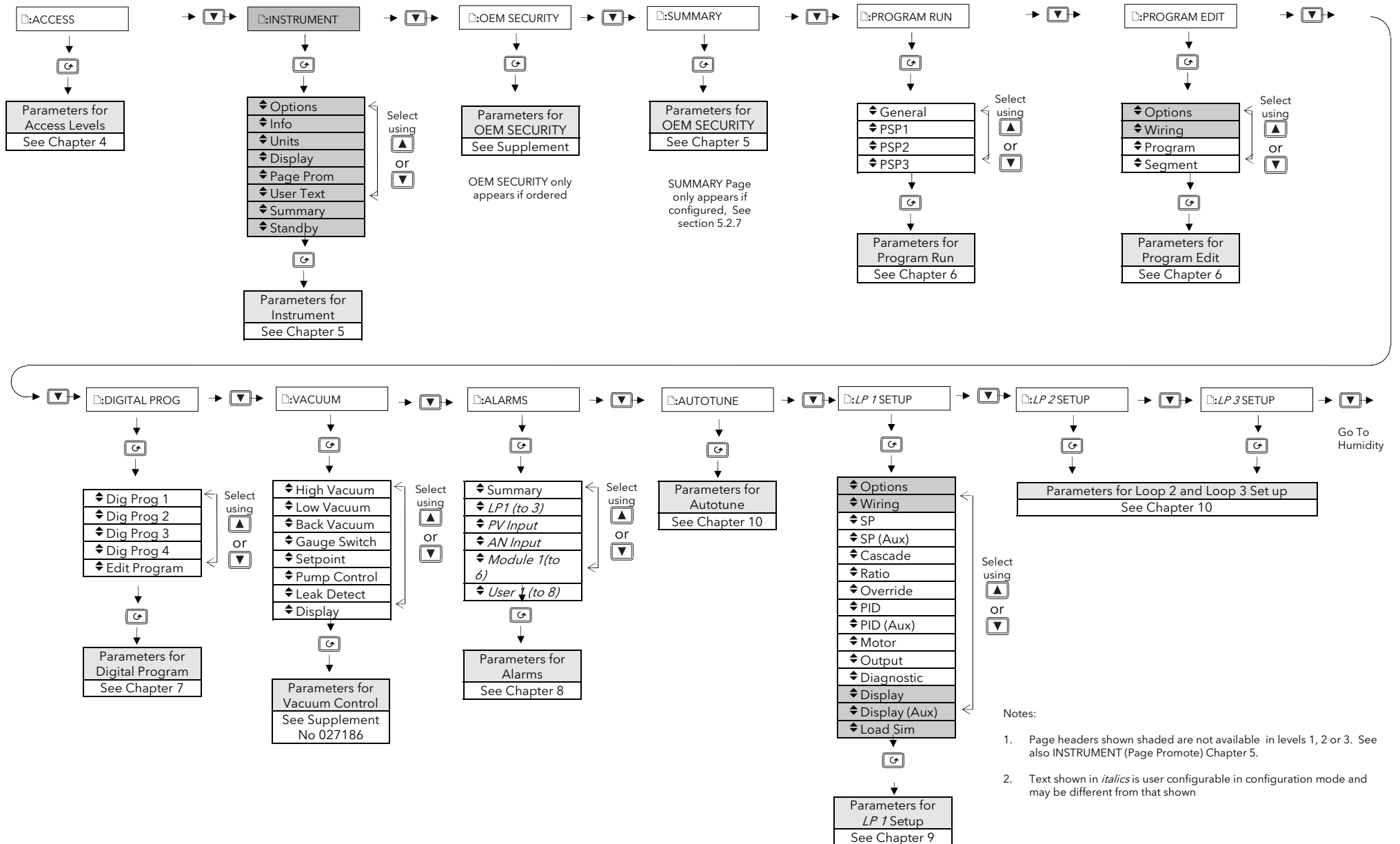
A parameter described as alterable is, generally, preceded by the \blacklozenge symbol which indicates that its value can be changed. A parameter which is not alterable may be viewed (subject to availability), but may be changed by an instrument algorithm.

A parameter is alterable only if the following conditions are satisfied:-

- The parameter is READ/WRITE
- The parameter does not conflict with the status of the instrument. For example, the proportional band will not be alterable if autotune is active
- The instrument keys must be enabled. Keys can be disabled by a logic input, turned off in configuration level or via digital communications. A logic input can be configured to disable front panel keys; this will not remove remote control of the user interface via digital communications.

The Navigation Diagram which follows shows all pages which are available at Config Level.

2.16 NAVIGATION DIAGRAM



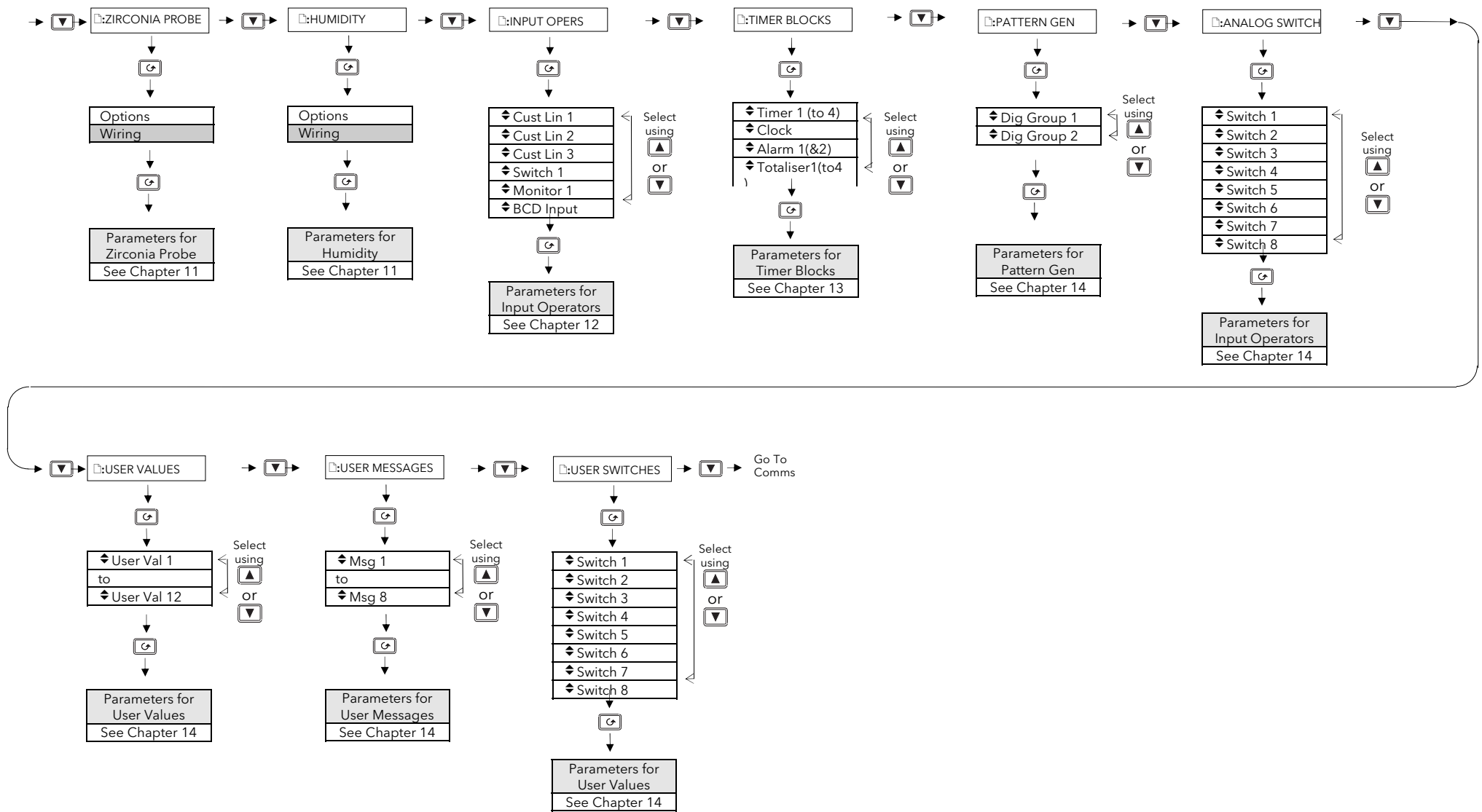
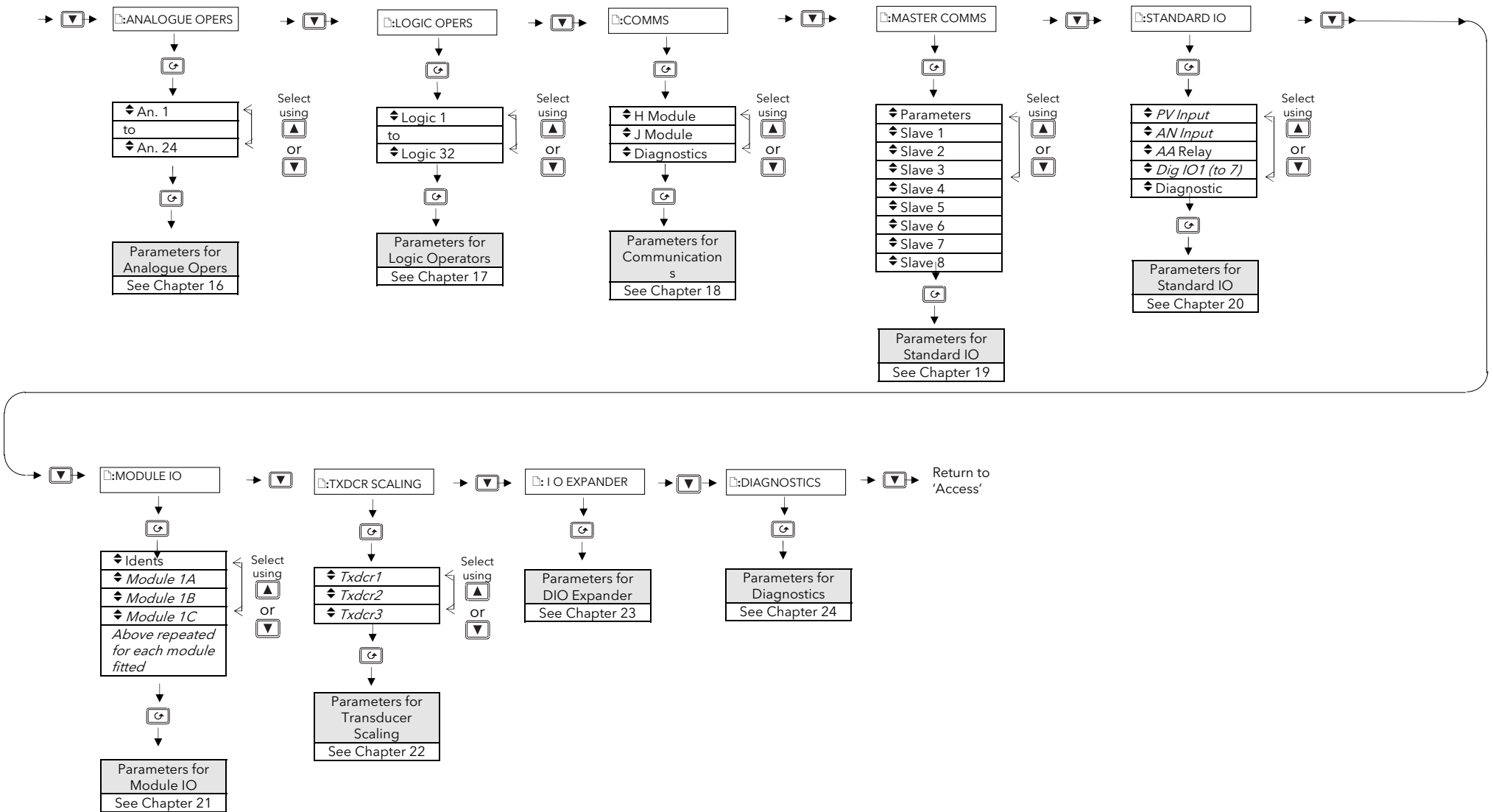


Figure 1-13: Navigation Diagram



3. CHAPTER 3 FUNCTION BLOCKS

3.1 WHAT IS A FUNCTION BLOCK?

A function block is a software device which performs a control strategy. Examples are PID Controller, Setpoint Programmer, Cascade Controller, Timer, etc. A function block may be represented as a 'box' which takes in data at one side (as 'Inputs'), manipulates the data internally (using parameter 'Settings') and 'outputs' data at the other side to interface with analogue or digital IO and other function blocks. Figure 2-1 shows a representation of a PID function block as used in the 2604 controller.

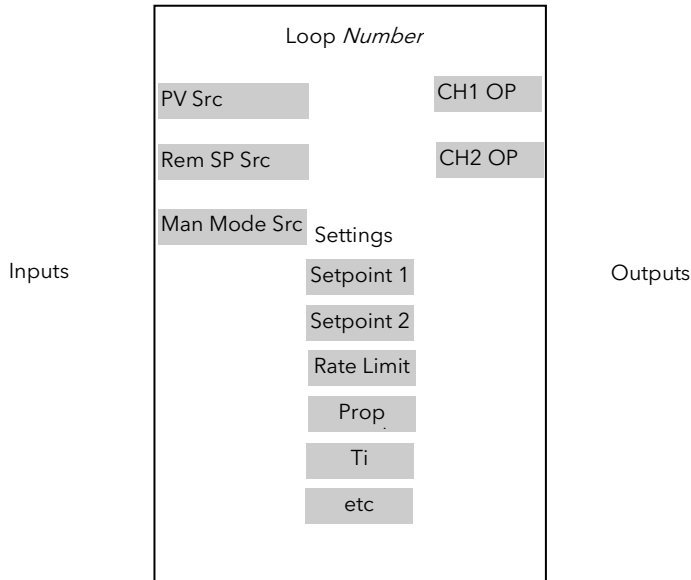


Figure 3-1: A Simple PID Function Block

3.1.1 Inputs

Inputs are provided to the function block from field sensors or from other function blocks within the controller. Each field input is served by an analogue or digital input block which processes the signal (depending upon the type of input) and makes it available to the function block in a useable form.

Each input 'wire' (see Chapter 3) is labelled as 'Src' since it defines the source of the signal by holding its Modbus address.

3.1.2 Outputs

In a similar way the function block makes available signals to other blocks, plant actuators and other devices. Each output interfaces with analogue or digital output drivers which provide signals to the plant such as relay, 4-20mA, 0-10V outputs, etc

3.1.3 Settings

The purpose of a particular function block is defined by its internal parameters. Some of these parameters are available to the user so that they can be adjusted to suit the characteristics of the plant.

Examples of parameters available to the user are shown in Figure 2-1 as 'Settings'. In this manual these parameters are shown in tables an example of which is shown in Section 1.12.

4. CHAPTER 4 SOFT WIRING

4.1 WHAT IS SOFT WIRING?

Soft Wiring (sometimes known as User Wiring) refers to the connections which are made in software between function blocks. This chapter describes the principles of soft wiring through the operator interface of the instrument. iTools configuration software, available from your supplier, enables you to configure this feature using a PC.

In general every function block has at least one input and one output. Input parameters are used to specify where a function block reads its incoming data (the 'Input Source'). The input source is usually soft wired to the output from a preceding function block. Output parameters are usually soft wired to the input source of subsequent function blocks.

It is possible to wire from any parameter using its Modbus address. In practice, however, it is unlikely that you will wish to wire from many of the available parameters. A list of commonly wireable parameters has, therefore, been produced and these are displayed in the controller with both their Modbus address and a mnemonic of the parameter name. An example is shown in the Section 3.1.2.1. i.e. 05108:PVIn.Val. The full list of these commonly wired parameters is given in Appendix D.

The function blocks used in this manual are drawn as follows:

1. Input parameters defined by 'Src' on the left of the function block diagram
2. Typically wired output parameters on the right hand side
3. Other parameters, which are not normally wired to, are shown as settings

A parameter which is not wired to can be adjusted through the front panel of the controller provided it is not Read Only (R/O) and the correct access level is selected.

All parameters shown in the function block diagrams are also shown in the parameter tables, in the relevant chapters, in the order in which they appear on the instrument display.

Figure 3-1 shows an example of how a PID function block (Loop 1) might be wired to other function blocks to produce a simple single loop controller. The 'PV Src' input is soft wired to the output value from the PV Input block on terminals V- to VH.

The channel 1 (heat) output from the PID block is soft wired to the input source ('Wire Src') of Module 1A, fitted as an output module.

Also in this example, a digital input to the 'Man Mode Src', allows the loop to be placed into manual depending upon the state of the digital input. The digital input is DIO1 connected to terminal D1 on the controller.

For further information on the configuration of the fixed IO and IO modules see Chapters 17 and 18 respectively.

Further examples of function block wiring are given in specific chapters throughout this manual.

4.1.1 An Example of Soft Wiring

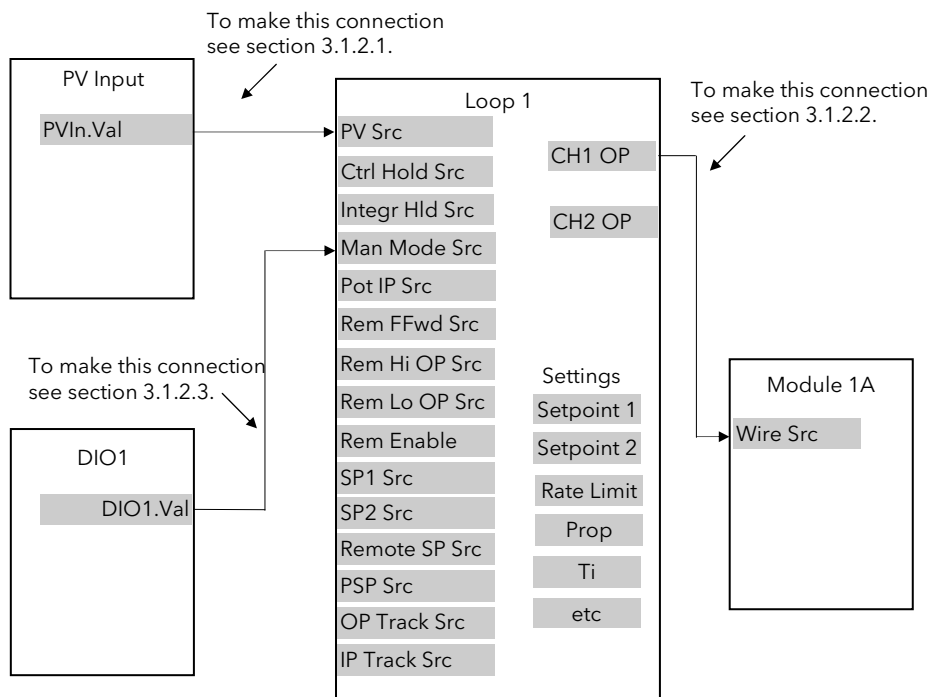


Figure 4-1: A Simple Wiring Example of a PID Function Block

4.1.2 Configuration of the Simple PID Loop










The following description explains how the wiring connections are made to produce the simple PID controller shown in Figure 3-1.

4.1.2.1 To connect the PV input to the Loop






The example is to connect the output from the 'PV Input' to the 'PV Source' of Loop 1.












Firstly, enter Configuration mode. This is further explained in Chapter 4.

Then:-

Do This	This Is The Display You Should See	Additional Notes
From any display press  as many times as necessary to select the module page header, i.e. STANDARD IO Press  or  to select the required Module Page, i.e. PV Input Page	<p style="text-align: center;">Select the wire source</p> <div style="border: 1px solid black; padding: 5px; width: fit-content; margin: auto;"> ST:STANDARD IO ◆ PV Input Page </div>	
Press  as many times as necessary to select PV Input. Val	<div style="border: 1px solid black; padding: 5px; width: fit-content; margin: auto;"> PV Input. Val 1 </div>	This selects the parameter to be wired from. Val denotes the output value.
Press  to copy this parameter. This button becomes a 'copy' button in this mode.	<div style="border: 1px solid black; padding: 5px; width: fit-content; margin: auto;"> Address 05108 Copied </div>	This display confirms that the parameter with Modbus address 05108 (ie PV Input.Val) has been copied. This display appears for as long as the A/M button is depressed
Press  as many times as necessary to select the loop set up page header i.e. LP1 SETUP Press  or  to select the Wiring Page	<p style="text-align: center;">Select the wire destination</p> <div style="border: 1px solid black; padding: 5px; width: fit-content; margin: auto;"> LP1 SETUP ◆ Wiring Page </div>	
Press  to select PV Src	<div style="border: 1px solid black; padding: 5px; width: fit-content; margin: auto;"> PV Src ◆ ----: None </div>	PV Src of LP1.is the parameter to be <u>wired to</u> . The flashing last character is the modbus address of the parameter to be <u>wired from</u> . If the address is known it can be entered directly here.




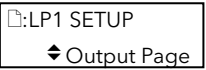

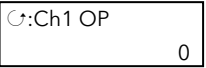

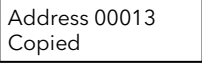



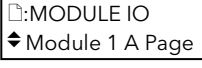

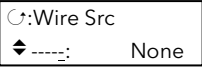
At this point you have three choices:

1. If the modbus address is known, enter it here by pressing the  or  button
2. If the modbus address is not known press . The display transfers to the name of the parameter. Press  or  to scroll through a list of parameter names. See Appendix D for the list of these parameters.
3. Paste the parameter (already copied) as follows


Press the Loop Select button,     to paste the copied parameter ie 05108 to the PV Src of LP1. This button becomes a 'paste' button in this mode	<p style="text-align: center;">Paste the wire source</p> <div style="border: 1px solid black; padding: 5px; width: fit-content; margin: auto;"> Paste 05108? →Cancel →OK </div>	The Loop Select button becomes a 'paste' button in this mode
Press  to confirm Press  to cancel as instructed	<div style="border: 1px solid black; padding: 5px; width: fit-content; margin: auto;"> PV Src ◆ 05108:PVIn.Val </div>	The parameter with Modbus address 05108 is pasted to PV Src. The last character flashes to indicate that you can change the modbus address if required, using the  or  button
Press  .	<div style="border: 1px solid black; padding: 5px; width: fit-content; margin: auto;"> PV Src ◆ 05108:PVIn.Val </div> <p style="text-align: center;">The connection is now made</p>	The display transfers to the name of the parameter. The last character flashes to indicate that you can change the parameter by name if required, using the  or  button


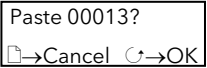


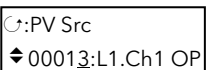



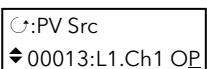


4.1.2.2 To connect the Loop to the Output Module

The example is Loop 1 Channel 1 output to Module 1A input.

Do This	This Is The Display You Should See	Additional Notes
<p>From any display press  as many times as necessary to select the Loop 1 Set Up page header, i.e. LP1 SETUP</p> <p>Press  or  to select the Output Page</p>	<p>Select the wire source</p> 	
<p>Press  as many times as necessary to select CH1 OP</p>		This selects the parameter to be wired from.
<p>Press  to copy this parameter.</p> <p>This button becomes a 'copy' button in this mode.</p>	<p>Copy the wire source</p> 	<p>This display confirms that the parameter with Modbus address 00013 (ie CH1 OP) has been copied.</p> <p>This display appears for as long as the A/M button is depressed</p>
<p>Press  as many times as necessary to select the Module IO page header i.e. Module IO</p> <p>Press  or  to select the Module 1 A Page</p>	<p>Select the wire destination</p> 	
<p>Press  to select Wire Src</p>		<p>This is the parameter to be <u>wired to</u>.</p> <p>The flashing last character is the modbus address of the parameter to be <u>wired from</u>.</p>

At this point you have three choices:

1. If the modbus address is known, enter it here by pressing the  or  button
2. If the modbus address is not known press . The display transfers to the name of the parameter. Press  or  to scroll through a list of parameter names
3. Paste the parameter (already copied) as follows

<p>Press the Loop Select button, , to paste the copied parameter ie 00013 to the Wire Src of Module 1A.</p> <p>This button becomes a 'paste' button in this mode</p>	<p>Paste the wire source</p> 	The Loop Select button becomes a 'paste' button in this mode
<p>Press  to confirm</p> <p>Press  to cancel as instructed</p>		<p>The parameter with Modbus address 00013 is pasted to Wire Src of module 1A.</p> <p>The last character flashes to indicate that you can change the modbus address if required, using the  or  button</p>
<p>Press </p>	 <p>The connection is now made</p>	<p>The display transfers to the name of the parameter.</p> <p>The last character flashes to indicate that you can change the parameter by name if required, using the  or  button</p>

 **Tip:**

You can page back by holding down the  button and pressing  button.

You can scroll back by holding down the  button and pressing  button.

4.1.2.3 To connect Digital Input DIO1 to Loop 1 Manual Input

The following description is given as a quick summary of the previous two examples.

1. Select the Wire Source 05402:DIO1.Val
2. Copy
3. Select the Wire Destination LP1 Man Mode Src
4. Paste

The source and destination of parameters is given in the **Parameter Tables** listed in following chapters.

5. CHAPTER 5 ACCESS LEVELS

5.1 THE DIFFERENT ACCESS LEVELS

There are five access levels:

Access Level	What you can do	Password Protection
Level 1	This is sometimes referred to as Operator Level since it allows operators to view and adjust parameters within limits set in higher levels. Any page available in levels 2 or 3 may be configured to appear in level 1. This is done from the configuration level using the page promote feature.	No
Level 2	This is sometimes referred to as Supervisor level since all the parameters relevant to a particular configuration are visible. All alterable parameters can be adjusted.	Yes
Level 3	These are parameters which are generally required when commissioning the controller. Any page at this level can also be configured to appear at level 2.	Yes
Config	This level allows access to configure the fundamental characteristics of the controller and it is this level which is described in this manual	Yes
View Config	This is a read only level which allows you to view the configuration of the controller. It is not possible to change parameter values in this level. It is not possible to read passcodes in this level.	Yes

5.2 PASSCODES

On switch on the controller defaults to Level 1 which is not protected by a passcode. A limited set of parameters can be changed in this level. The parameter tables in each chapter list those parameters which can be changed.

Level 2, level 3 and Configuration level are protected by passcodes. The default passcodes set in a new controller are:

Level 2	Passcode '2'
Level 3	Passcode '3'
Config	Passcode '4'
View Config	Passcode 2604 (Fixed)




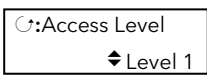


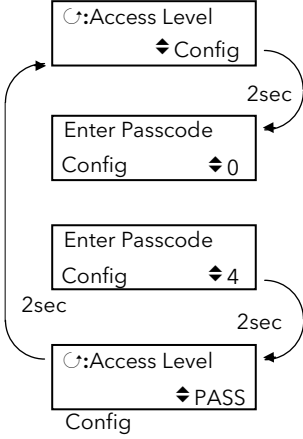


These passcodes with the exception of View Config can be changed in configuration level.

If a passcode of 'None' has been entered for any level (apart from View Config, which is fixed) it will not be necessary to enter a passcode to enter that level.

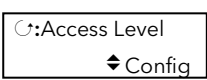

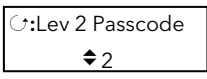



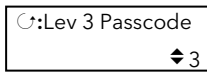



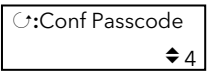


5.3 TO ENTER CONFIGURATION LEVEL

Note:-

In configuration mode the controller enters a standby state in which all outputs are frozen. If the controller is connected to a process it will not control the process when in this mode.

Do This	This Is The Display You Should See	Additional Notes
From any display press  as many times as necessary until the ACCESS page header is displayed		
Press  to select Access Level		
Press  or  to select the required access level. E.g. Config		<p>The default passcode of a new controller is 4 to enter config level. If a new passcode has been previously entered it will be in the form 0 to 9999.</p> <p>If an incorrect passcode is entered, the display returns to 0.</p> <p>Note: In the special case that the passcode has been configured as 'None', the display will blink momentarily when Config Level is selected and Config Level will be entered immediately</p>
Press  or  to enter the passcode.		
When the correct passcode is entered the display momentarily changes to PASS , then back to the start level to confirm correct entry.		

5.4 TO ENTER NEW PASSCODES

Do This	This Is The Display You Should See	Additional Notes
From the previous display		When the controller is in configuration level the upper display will show CONF The middle display will change depending on the parameter selected
Press  to select Lev 2 Passcode		The display will blink to accept the new passcode
Press  or  to select a new passcode for level 2		
Press  to select Lev 3 Passcode		The display will blink to accept the new passcode
Press  or  to select a new passcode for level 3		
Press  to select Conf Passcode		The display will blink to accept the new passcode
Press  or  to select a new passcode for configuration level		

5.5 TO EXIT CONFIGURATION LEVEL

To exit configuration level it is only necessary to select the level which you wish to go to. When entering a new level from a higher level it is not necessary to enter the passcode for this level. It is only necessary to enter the passcode when going from a lower level of access to a higher level.




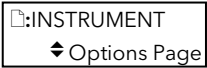
6. CHAPTER 6 INSTRUMENT CONFIGURATION

6.1 WHAT IS INSTRUMENT CONFIGURATION?

Instrument configuration allows you to set up features such as:-

1. The number of loops
2. To enable/disable. PID Loops, Programmer, Zirconia, Humidity, Input Operators, Timer Blocks, Analogue and Logic Operators, Transducer Scaling
3. Displayed Units
4. The format of the upper, middle and lower readouts
5. The functions of the keys (buttons)
6. Promotion of selected parameters to different levels
7. User text
8. Format of the Summary Page
9. Standby Behaviour

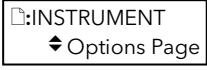



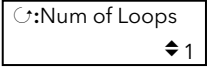



6.1.1 To Select the Instrument Configuration Pages

Do This	This Is The Display You Should See	Additional Notes
<ol style="list-style-type: none"> 1. From any display press  as many times as necessary until the INSTRUMENT page header is displayed 2. Press  or  to select the sub header, e.g. Options Page 		<p>The choice of page headers is:-</p> <ul style="list-style-type: none"> Options Page Info Page Units Page Display Page Page Prom Page User Text Page Summary Page Standby Page


Note:-

It is only possible to configure chargeable options if they have been ordered. An example of a chargeable option is the number of loops. For other chargeable options see Order Code, Appendix A.



6.2 TO CONFIGURE CONTROLLER OPTIONS

Do This	This Is The Display You Should See	Additional Notes
<ol style="list-style-type: none"> 1. Select INSTRUMENT (Options Page) as shown in the previous section 		
<ol style="list-style-type: none"> 2. Press  to select the first parameter in the list for this page. This is 'Num of Loops' 3. Press  or  to select the required number of loops 		<p>1, 2 or 3 loops can be selected if the option has been supplied</p> <p>A full list of parameters available in this page is shown in the following table on the next page.</p> <p>Parameters are selected using  and their values may be changed using  or </p> <p style="text-align: center;">↓</p>




6.2.1 INSTRUMENT Options Page

Table Number: 5.2.1.		These parameters allow you to enable or disable instrument options which have been ordered		INSTRUMENT (Options Page)	
Parameter Name Press  to select	Parameter Description	Value	Further Information	Access Level	
Num of Loops *	To configure the number of loops	1, 2 or 3	Chapter 9	Config	
Programmer *	To enable or disable the programmer	Disabled Enabled	Chapter 7	Config	
Digital Prog *	To enable or disable the digital programmer	Disabled Enabled	Chapter 8		
Zirconia *	To enable or disable a zirconia block	Disabled Enabled	Chapter 8	Config	
Humidity	To enable or disable the humidity block	Disabled Enabled	Chapter 12	Config	
Input Opers	To enable or disable the Input Operators	Disabled Enabled	Chapter 12	Config	
Timer Blocks	To enable or disable the Timer Blocks	Disabled Enabled	Chapter 14	Config	
Patter Gen	To enable or disable the Pattern Generator	Disabled Enabled	Chapter 15		
Analog Switch	To enable or disable analog switches	Disabled Enabled	Chapter 15		
An/Logic Opers *	To enable or disable the Analogue and Logic Operators	Disabled Enabled	Chapter 15	Config	
Txdcr Scaling	To enable or disable transducer scaling	Disabled Enabled	Chapter 22		
IO Expander	To enable or disable the IO Expander	Disabled Enabled	Chapter 23		
Master Comms	To enable or disable master communications	Disabled Enabled	Chapter		
Load Sim A Technical Note, Ref TIN123 is available for further information.	To enable or disable load simulation. This allows a simulation of a control loop to be enabled for test and demonstration purposes	Disabled Enabled	Technical note TIN123		

* These are options which can only be activated if they have been ordered, see 'Ordering Code' Appendix A.

Further pages are available under the INSTRUMENT heading as sub-headers. These are selected using  or . They are:-

- Options Page
- Info Page
- Units Page
- Display Page
- Page Prom Page
- User Text Page
- Summary Page
- Standby Page

The following tables list the parameters available in each of these pages. Parameters are selected as above using  and their values can be changed using  or .

6.2.2 INSTRUMENT Info Page


Table Number: 5.2.2.		These parameters, all available in Level 3, give you information about the controller		INSTRUMENT (Info Page)
Parameter Name Press \odot to select	Parameter Description	Value	Default	Access Level
Inst Type	Instrument type	2604	2604	R/O
Inst Serial No	Instrument serial number	Numeric		R/O
Inst Version	Software version	e.g. V5.00		R/O
CBC Version	Software version number of the 'cross board'	e.g. 45 (version no 4.5)		R/O
Feature Code 1	Codes required to upgrade	Numeric		R/O
Feature Code 2	chargeable features	Numeric		R/O
Inst 2 nd Lang	Instrument language for user interface			R/O
Alt Protocol	Alternative digital communications protocol	EI Bisynch Modbus Profibus Devicenet		R/O
ROM Size	ROM Size	eg 256K Word		R/O
RAM Size	RAM Size	eg 32K Bytes		R/O

6.2.3 INSTRUMENT Units Page

Table Number: 5.2.3.		These parameters allow you to configure instrument units		INSTRUMENT (Units Page)
Parameter Name Press \odot to select	Parameter Description	Value	Default	Access Level
Temp Units	Temperature Units	None °C, °F, °K		
Custom Units 1	An index of customised display units selected from 'User Text' See section 0.		01:Usr01	Conf
Custom Units 2		01:Usr01	01:Usr01	Conf
Custom Units 3		to	01:Usr01	Conf
Custom Units 4		50:Usr50	01:Usr01	Conf
Custom Units 5			01:Usr01	Conf
Custom Units 6			01:Usr01	Conf

6.2.4

6.2.5 INSTRUMENT Display Page

Table Number: 5.2.4. These parameters allow you to configure the display		INSTRUMENT (Display Page)		
Parameter Name Press  to select	Parameter Description	Value	Default	Access Level
Language	Display language	See note 1		Conf
Startup Text 1	Text which may be used to override the default message	01:Usr01 to 50:Usr50	Default Text	L3
Startup Text 2	Up to 50 text strings are available	01:Usr01 to 50:Usr50	Default Text	L3
Upper Param	To define which parameter will be displayed in the upper readout in operation level	See note 2		Conf
Middle Param	To define which parameter will be displayed in the middle readout in operation level	See note 2		Conf
Home Page	Defines which page is displayed in the lower readout after initialisation	See Note 3		L3
Home Timeout	To set a timeout for the display to return to the Home page.	None 9:99:99.9	0:10:00	Conf
All Loops Name	All loops summary page name	01:Usr01 to 50:Usr50	Default Text	Conf
Disable Keys	Yes will disable all front panel buttons when in operation levels	No Yes	No	Conf
Function Key 1	Function key 1 is Auto/Manual or disabled	Auto/Manual Disabled	Auto/Man	Conf
Function Key 2	Function key 2 is Loop Select key or disabled	View Loop Disabled	View Loop	Conf
Function Key 3	Function key 1 is Program Run/Hold or disabled	Run/Hold Disabled	Prog Run/Hold	Conf
Disable Keys S	Disable all keys source	Keys may be wired to an external source. E.g. a digital input for remote panel operation. The source is defined by a Modbus address. See also Chapter 3	None	Conf
Page Key Src	Page key source		None	Conf
Scroll Key Src	Scroll key source		None	Conf
Lower Key Src	Lower key source		None	Conf
Raise Key Src	Raise key source		None	Conf
Func Key 1 S	Function key 1 source		None	Conf
Func Key 2 S	Function key 2 source		None	Conf
Func Key 3 S	Function key 3 source		None	Conf
Func1 Pressed	State of function key 1	No	No	Conf
Func2 Pressed	State of function key 2	Yes	No	Conf
Func3 Pressed	State of function key 3	Note 4	No	Conf

Note 1:-

The 2604 stores the user interface in 2 languages. English is always available plus French, German or Spanish.

Note 2:-

Any parameter can be displayed in the upper and lower readout and wired to front panel buttons. For convenience the most often used parameters have been provided in the controller together with their Modbus addresses. A list of these parameters together with their Modbus addresses is given in Appendix D.

Note 3:-

The first page to be displayed when the instrument is switched on can be chosen from:-

Summary Page

Run Page

Loop 1, Loop 1 Aux., Loop 2, Loop 2 Aux., Loop 3, or Loop 3 Aux.

Access Page




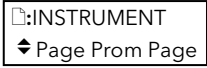



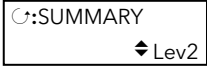
Cycle Each Loop

Note 4:-

These parameters are generally only used over digital communications

6.2.6 INSTRUMENT Page Promote Page

Any page shown un-shaded in the Navigation Diagram, Figure 1-14, can be promoted to Level 1, Level 2 or Level 3 as follows:-

Do This	This Is The Display You Should See	Additional Notes
1. From any display press  as many times as necessary until the INSTRUMENT page header is displayed 2. Press  or  to select Page Prom Page		
3. Press  to select the pages which you wish to promote to Levels 1, 2 or 3. 4. Press  or  to select Lev1 , Lev2 , or Lev3 .		In this view the Summary page will only be displayed at Level 2 (and Level 3). It will not be shown at Level 1

All pages listed in the Navigation Diagram section 1.14. are available in Level 3, but they can be promoted to any level using the procedure above.




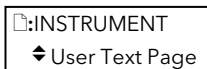



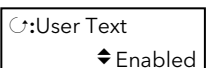



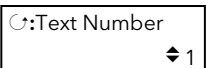



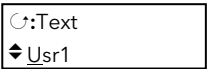



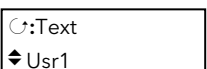
By default the pages shown in the following table are available in Level 1. Any page available in a lower level is automatically available in a higher level.

Parameter Name	Default Level
SUMMARY	Lev1
PROGRAM RUN (General)	Lev1
PROGRAM RUN (PSP1)	Lev1
PROGRAM RUN (PSP2)	Lev1
PROGRAM RUN (PSP3)	Lev1
PROGRAM EDIT (segment)	Lev1
ALARMS (All pages)	Lev1

6.2.7 INSTRUMENT User Text Page

This page allows you to configure up to 50 User Text strings of up to 16 characters. Any string can be used to provide a name for particular parameters. For example Loops can be given names which are more meaningful to the user, such as 'Zone 1', 'Level Controller', etc.


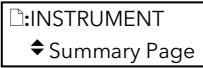



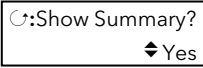



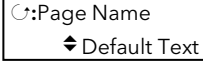



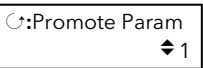



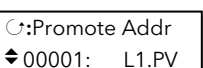



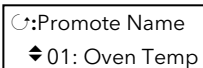



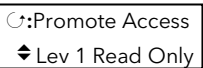



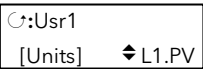

To enter User Text:-

Do This	This Is The Display You Should See	Additional Notes
1. From any display press  as many times as necessary until the INSTRUMENT page header is displayed 2. Press  or  to select User Text Page		
3. Press  to select User Text 4. Press  or  to enable User Text		If Disabled no further pages are available
5. Press  to select Text Number 6. Press  or  to select the Text Number		Up to 50 Text Numbers are available
7. Press  to select Text 8. Press  or  to change the first (flashing) character to the first character of your text.		Repeat this step for all characters - up to 16
9. Press  to select the next character up to 16 characters 10. Press  or  to change the (flashing) character.		

6.2.8 INSTRUMENT Summary Page

This page allows you to configure a page consisting of a list of 10 parameters which are in common use on a particular installation. The first parameter in the list - 'Show Summary' must be enabled so that the Summary list can be shown in operating levels.

To configure Summary pages:-

Do This	This Is The Display You Should See	Additional Notes
1. From any display press  as many times as necessary until the INSTRUMENT page header is displayed		The level at which the Summary Page is shown is selected by the Page Promote section 5.2.5.
2. Press  or  to select Summary Page		
3. Press  to select Show Summary?		If Yes is selected the Summary Page will be shown in the Main Menu see Navigation Diagram, section 1.14
4. Press  or  to select Yes or No		If 'No' is selected the Summary page will not be shown.
5. Press  to select Page Name		Up to 50 user defined text Names are available.
6. Press  or  to select a name for the page from 'User Text'		The previous section explains how User Text is set up.
7. Press  to select Promote Param		This selects the first parameter which will appear on the summary page. Up to 10 parameters may be listed.
8. Press  or  to select '1' (if necessary)		
9. Press  to Promote Addr		The Modbus address is shown on the left of the lower readout. The mnemonic is shown on the right.
10. Press  or  to select the parameter from its Modbus address		Only the more typical names (listed in Appendix D) are displayed
11. Press  to select Promote Name		Every parameter promoted to the Summary page can be given a user defined name chosen from 'User Text'
12. Press  or  to choose between default text or user text configured as in section 5.2.5.		The text 'Oven Temp' is used in this example.
13. Press  to select the Promote Access level		This sets the level to which the parameter is promoted. The choices are:- Lev 1 Read Only Lev 1 Alterable Lev 2 Read Only Lev 2 Alterable
14. Press  or  to select the Access Level		
15. If a parameter has been selected to appear on the Summary page, then pressing  will show how that parameter will appear.		The actual value of the parameter is shown in this display together with its allocated units. If more parameters have been chosen to appear on the Summary page they will be listed in turn after each press of 




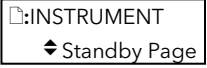



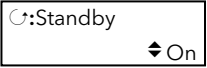



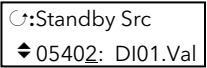
Repeat the above steps for 10 parameters which are to be promoted to the Summary page header.

6.2.9 INSTRUMENT Standby Page




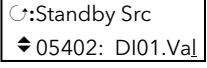
The standby state of the controller occurs when it is in configuration mode or during the first few seconds after switch on.

The INSTRUMENT Standby Page allows you to wire to a parameter such as a digital input which when true will switch the controller to Standby Mode.

6.2.9.1 Example:- To Wire Standby to Fixed Digital Input 1.

Do This	This Is The Display You Should See	Additional Notes
1. From any display press  as many times as necessary until the INSTRUMENT page header is displayed 2. Press  or  to select Standby Page		
3. Press  to select Standby 4. Press  or  to select On or Off		'On' enables the feature 'Off' disables the feature.
5. Press  to select Standby Src 6. Press  or  to edit the Modbus Address of the parameter to be wired to		The Modbus Address of Fixed Digital Input number 01 is 05402

If the Modbus Address is not known it is possible to select the required parameter from a list of commonly used parameters. This list is shown in Appendix D

7. Press  again. 8. Then press  or  to scroll through a list of commonly used parameters		If the Modbus Address is not known the parameter can be selected its mnemonic. See Appendix D for a list of these commonly used parameters.
--	---	---

 **Tip:** See 'Copy and Paste' Section 3.1.2.

6.3 USER TEXT EXAMPLES

6.3.1 To Re-Name Loop 1 to Zone 1

First enable User Text since its factory default is disabled. A library of User Text can then be created from which the new loop name can be selected.

6.3.1.1 Implementation

1. In INSTRUMENT/User Text Page (Section 5.2.6),
 - set User Text = Enabled
 - set 'Text Number' = 1 (or any unused text no.)
 - set 'Text' = Zone 1
 - This defines Text Number 1 to be Zone 1.
2. In LOOP 1 SETUP /Display Page
 - set 'Loop Name' = 01:Zone 1
 - This replaces the default name (LP1) with Zone 1

6.3.2 To Re-Name User Alarm 1 and Provide a Message

User alarms can be re-named and also provide a diagnostic message to the user.

6.3.2.1 Implementation

1. In INSTRUMENT/User Text Page (Section 5.2.6),
 - set User Text = Enabled
 - set 'Text Number' = 2 (or any unused text no.)
 - set 'Usr2' = High Temp
 - This defines Text Number 2 to be High Temp.
 - set 'Text Number' = 3 (or any unused text no.)
 - set 'Usr3' = Check Chiller
2. In ALARMS/User 1 Page
 - set 'Name' = 02:High Temp
 - This replaces the default name with High Temp
 - Set 'Message' =03:Check Chiller

6.3.3 To Re-Name Module 1 to be called Heat Output

Individual modules can be re-named to simplify plant diagnostics.

6.3.3.1 Implementation

1. In INSTRUMENT/User Text Page (Section 5.2.6),
 - set User Text = Enabled
 - set 'Text Number' = 4 (or any unused text no.)
 - set 'Usr4' = Heat Output
 - This defines Text Number 4 to be Heat Output.
2. In MODULE IO/Module 1A Page
 - set 'Module Name' = 04:Heat Output
 - This replaces the default name with Heat Output

6.3.4 To Show User Text in the Summary Page on an Event

This example will display the text 'Test 1' in the Summary Page when the Digital Input 1 becomes true.

6.3.4.1 Implementation

1. In INSTRUMENT/User Text Page (Section 5.2.6),
 - set User Text = Enabled
 - set 'Text Number' = 5 (or any unused text no.)
 - set 'Usr5' = Test 1
2. In STANDARD IO /Dig IO1 Page
 - set Channel Type = Digital Input
 - This page also allows you to set the input for inverted operation
3. In INSTRUMENT/Summary Page (Section 5.2.7)
 - set 'Show Summary?' = Yes
 - set 'Promote Param' = 1 (or the text no. above)
 - set 'Promote Addr' = 05402:DIO1.Val
 - This connects digital input 1 to the first parameter of the Summary display

In Operation Level, the text in the Summary page will show: C:Test 1
0 or 1

In place of 0 or 1, you may wish to display On or Off. This can be achieved by using a Logic or Analogue Operator. The implementation using Logic Operator 1 is as follows:

1. In INSTRUMENT/User Text Page (Section 5.2.6),
 - set User Text = Enabled
 - set 'Text Number' = 5 (or any unused text no.)
 - set 'Usr5' = Test 1
2. In STANDARD IO /Dig IO1 Page
 - set Channel Type = Digital Input
 - This page also allows you to set the input for inverted operation
3. In LOGIC OPERS/Logic 1 Page
 - set 'Operation = OR
 - set 'Input 1 Src = 05402:DIO1.Val
 - set 'Input 2 Src = 05402:DIO1.Val
 - This connects digital input 1 to logic operator 1. Note: it is necessary to wire to both inputs of a logic (or analogue operator)
4. In INSTRUMENT/Summary Page (Section 5.2.7)
 - set 'Show Summary?' = Yes
 - set 'Promote Param' = 1 (or the text no. above)
 - set 'Promote Addr' = 07176:LgOp1.OP
 - The logic operator is defined simply to provide On/Off annunciation in the display Summary page.

See Appendix D for list of Modbus addresses.

6.3.5 To Assign Custom Units to the Power Up Display

Most commonly used units can be selected for display on the user interface. In addition to the standard selection up to six custom units can be created. In this example the units of the PV Input will be Gal/m

6.3.5.1 Implementation

1. In INSTRUMENT/User Text Page (Section 5.2.6),
 - set User Text = Enabled
 - set 'Text Number' = 6 (or any unused text no.)
 - set 'Usr6' = Gal/m
 - This defines Text Number 6 to be Gal/m.
2. In INSTRUMENT/Units Page (Section 5.2.3),
 - set 'Custom 1 Units' = 06:Gal/m
 - This sets Custom Units 1 to Gal/m
3. In STANDARD IO/PV Input Page (Table 17.2.1.)
 - set 'Units' = Custom 1

6.3.6 To Customise the Power Up Display

In this example the users company name will be used provide the start up message when the controller is switched on. The company name will be CML Controls and is based in Scotland.

6.3.6.1 Implementation

1. In INSTRUMENT/User Text Page (Section 5.2.6),
 - set User Text = Enabled
 - set 'Text Number' = 7 (or any unused text no.)
 - set 'Usr7' = CML Controls
 - This defines Text Number 7 to be CML Controls
 - set 'Text Number' = 8 (or any unused text no.)
 - set 'Usr8' = Scotland
2. In INSTRUMENT/Display Page (Section 5.2.4),
 - set 'Startup Text 1' = 07: CML Controls
 - set 'Startup Text 2' = 08: Scotland

7. CHAPTER 7 PROGRAMMER CONFIGURATION

This chapter explains how to configure and use a Setpoint Programmer and describes in more detail other features such as:-

- Program **User Values**
- **Pattern Generator**
- **Program, Segment** and other **User Defined Names**
- The strategy adopted by the controller following a **power fail**
- Other parameters applicable to **configuration of programmers**
- A description of **Holdback**

Customisable Parameter Names

Throughout this chapter parameter names shown in *italics* are customisable by the user when in configuration access level. The name of the parameter may vary, therefore, from instrument to instrument.

Typical customisable parameter names are:

- Program names
- Profile Setpoint names
- User Value names

7.1 WHAT IS SETPOINT PROGRAMMING ?

Many applications need to vary the process value over time. Such applications need a controller which varies a setpoint as a function of time. The 2604 controller will program up to three separate profiles. These may be temperature, pressure, light level, humidity, etc., depending on the application, and are referred to as **Profiled Setpoints (PSPs)**. A setpoint program containing three profile setpoints is shown in Figure 6-1.

The **Program** is divided into a flexible number of **Segments** - each being a single time duration, - and containing details for each profiled setpoint. The total number of segments available is **100 per program** with a **maximum of 500** in any instrument.

A controller containing functionality to control profile setpoints against time is referred to as a **Programmer**. The 2604 programmer works on a single timebase for all programs.

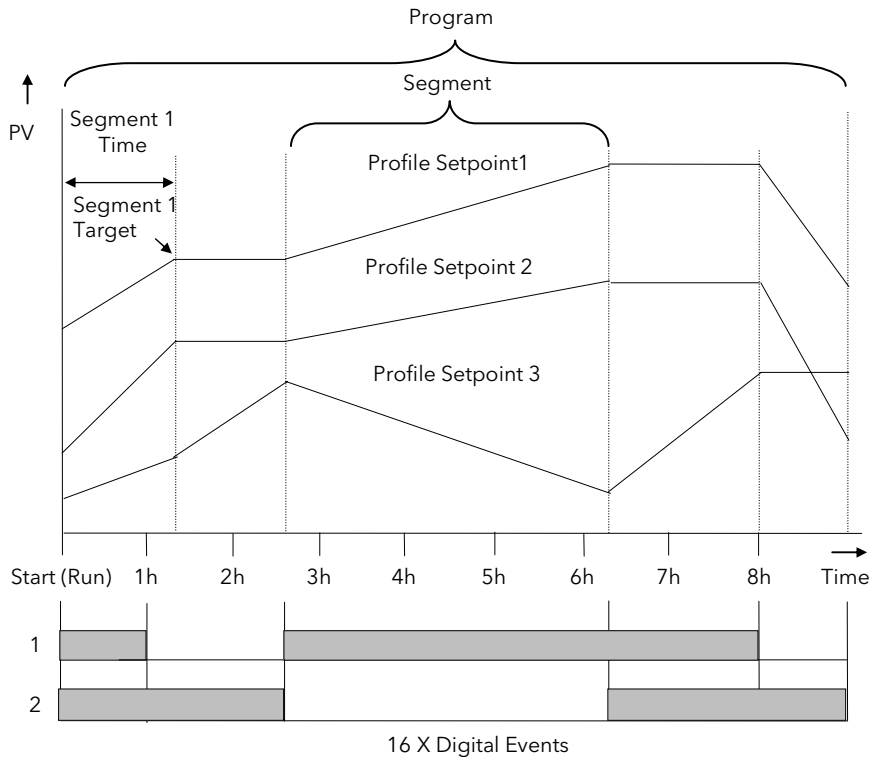


Figure 7-1: A Setpoint Program

The profiled setpoints may be used as either **control loop setpoints** or independent parameters for **retransmission** or for use in **derived calculations**.

The 2604 may store up to **20 programs** as standard, with up to 50 if purchased.

7.2 THE 2604 SETPOINT PROGRAMMER DEFINITIONS

7.2.1 Run

In run the programmer varies the setpoint in accordance with the profile set in the active program.

7.2.2 Hold

In hold the programmer is frozen at its current point. In this state you can make temporary changes to program parameters such as a target setpoint, ramp rates and dwells (if programmer configured for ramp rate) or segment duration (if programmer configured as Time to Target). Such changes will only remain effective until the end of the currently running segment, when they will be overwritten by the stored program values.

7.2.3 Reset

In reset the programmer is inactive and the controller behaves as a standard controller, with the setpoint determined by the raise/lower buttons.

7.2.4 Servo

When a program is run the setpoint can start from the initial controller setpoint or from the current process value. Whichever it is the starting point is called the servo point. This can be set in the program.

The usual method is to servo to the process value because this will produce a smooth and bumpless start to the process.

If, however, it is essential to guarantee the time period of the first segment it may be better to set the controller to servo to setpoint.

7.2.5 Hot Start

Hot start can occur in any segment type, for any PSP but is most useful to ramp segments. When run is initiated it allows the program to automatically advance to the correct point in the profile which corresponds to the operating temperature of the process. Hot start is enabled in configuration level and specifies which programmed variable to use when deciding the correct segment.

7.2.6 Digital Inputs

Digital inputs are available on the controller which can be configured for the following programmer functions:

Run	Allows the program to be run from an external source such as a pushbutton or other event
Hold	Allows the program to be held from an external source such as a pushbutton or other event
Reset	Allows the program to be reset from an external source such as a pushbutton or other event
Run/Hold	Allows the program to be run or held from a single external input source
Run/Reset	Allows the program to be run or reset from a single external input source
Advance Segment	Selects the next segment from an external input source
Program Number	Selects the next program from an external input source. When this event occurs, the controller display will change to programmer view. Subsequent changes of this input source will cause the program number to increment.
Holdback disabled	Disables holdback from an external input source
BCD Program switch	Allows different programs to be selected using an external BCD switch

For more information on digital inputs refer to Chapters 17 and 18.

7.2.7 Power Fail Recovery

In the event of power fail to the controller, a strategy may be set in configuration level, which defines how the controller behaves on restoration of the power. These strategies include:

<p>Continue</p>	<p>The program runs from the last setpoint. This may cause full power to be applied to the process for a short period to heat the process back to its value prior to the power failure</p>	
<p>Ramp back</p>	<p>The PV will ramp back to its original value at the rate last encountered. In a Dwell segment, the period continues when the PV recovers to the SP value. The power fail time + the recovery time is added to the dwell time set.</p>	
	<p>A special case exists if no ramps have been encountered. The diagram shows the behaviour following a power fail in segment 3.</p>	
<p>Reset</p>	<p>The process is aborted by resetting the program</p>	
<p>Hold Program</p>	<p>The programmer will enter the HOLD state. The operator may then change the state to Reset or Run. On exiting from Hold into Run the program will continue, it will not ramp back.</p>	
<p>Test Time</p>	<p>This option makes use of the real time clock in the controller to determine how long the power has been off. Two time periods can be set which allows three strategies:</p> <ol style="list-style-type: none"> 1. If the power is off for less than the first period, the programmer will continue from its last operating point 2. If the power is off for a time between the two time boundaries, the controller will servo to the PV and ramp back to the operating point using the previous ramp rate. 3. If the power is off for longer than the second time boundary, the programmer will reset. <p>☺ The programmer takes about 25 seconds to start running after power is applied to the 2604. This delay should be taken into consideration when setting up the Test Time recovery parameter.</p>	

7.2.8 Wait

Three wait conditions are provided at the end of each segment which may be wired, in configuration level, using a 'Toolkit Block' expression or by a digital input. Each segment may then select No-Wait, Wait on Event A, Wait on Event B or Wait on Event C. When all profile segments are complete, and the configured wait event is active, the program waits until the wait event becomes in-active before progressing to the next segment.

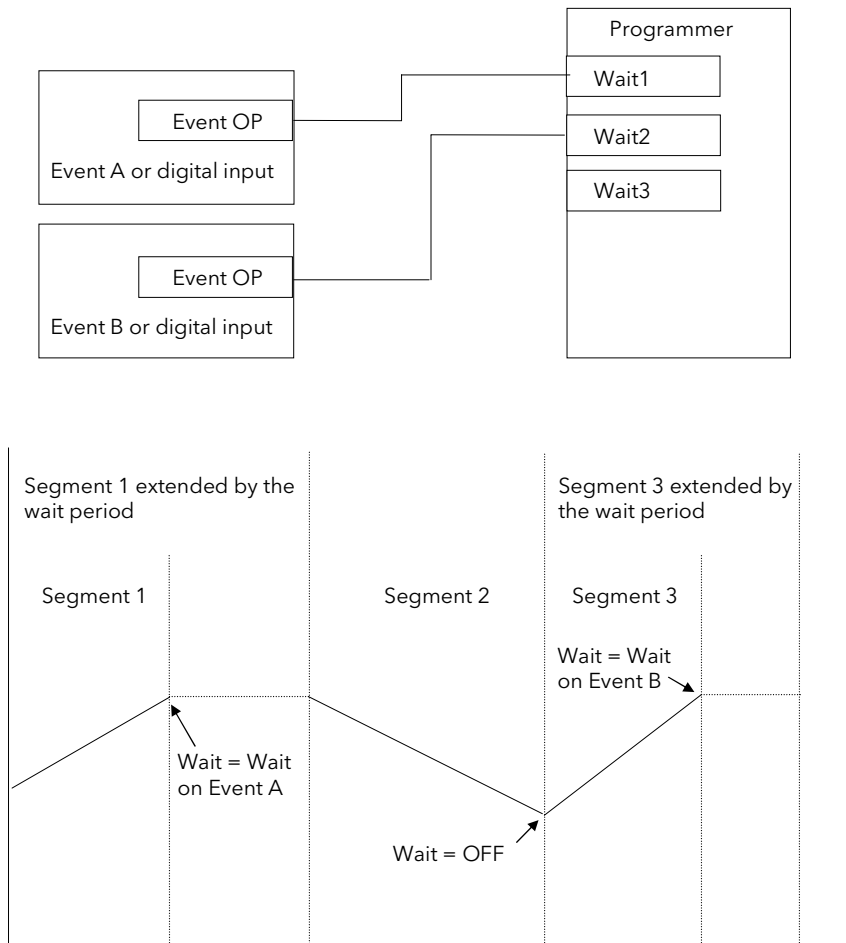


Figure 7-2: Wait Events

7.2.9 Holdback (Guaranteed Soak)

Holdback freezes the program if the process value does not track the setpoint by an amount which can be set by the user. It may operate in any type of segment

In a **Ramp** segment it indicates that the process value is lagging the setpoint by more than a pre-set amount and that the program is waiting for the process to catch up.

In a **Dwell** segment it will freeze the dwell time if the difference between SP and PV exceeds pre-set limits.

In both cases it guarantees the correct soak period for the product.

Holdback may be configured in three modes:

- OFF - holdback does not operate
- Applied to the complete program. Holdback operates the same way in every segment
- To each individual segment. A different holdback type can be applied to each segment

Holdback Mode defines how holdback operates. It may apply when:

- The PV is below the SP by a pre-set value (Lo),
- The PV is above the SP by a pre-set value (Hi)
- The PV is below or above the SP by a pre-set value (Band).

In addition two levels of holdback are available per profile setpoint, per program. These are defined as 'Fine' and 'Course'.

Example:

Holdback, operating in each segment, is often used in a temperature control application as detailed below:-

During a ramp up period the holdback type may be set to deviation low. If the Process Value lags the programmed rate of rise, holdback will stop the program until the PV catches up. This prevents the set program from entering the next segment until the PV has attained the correct temperature.

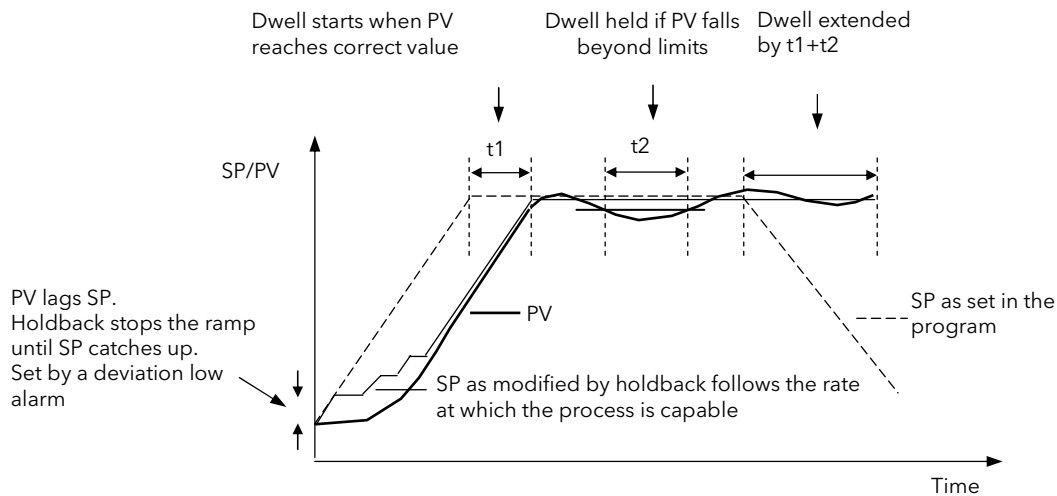


Figure 7-3: Effect of Holdback to Produce Guaranteed soak

During a dwell period the holdback type may be set to deviation band. This guarantees that the dwell or soak period operates only when the process value is within both high and low deviation limits.

During a ramp down period the holdback type may be set to deviation high. If the process cannot cool at the rate set by the ramp down rate the program will be held until the process catches up.

When a profile is placed into holdback the other profiles are (normally) not held. They continue and rendezvous at the end of the segment.

Each segment may consist of up to three profiles. Two levels of holdback value, course and fine, may be applied for each profile of each segment in the PROGRAM EDIT Program page.

7.2.10 Fine and Coarse Holdback

Fine and Coarse Holdback values are only displayed when 'Holdback Mode' = 'Per Segment' or 'Per Program'. They allow you to apply one value of holdback to selected segments/program and another value to other segments/program. For example, you could apply 'Fine Holdback' to one or more Dwell segments and 'Coarse Holdback' to one or more Ramp segments

7.3 PROGRAM USER VALUES

Program User Values provide multiplexor facilities for the user. Each user value provides storage for a number of event values (currently 100). Each user value will normally be soft wired (see Chapter 3) to call up another feature.

The following example shows how the programmer user values may be used to call up different sets of pre-configured digital output values for different segments in a programmer. This would make use of the Pattern Generator described in Chapter 15, and assumes that a user value has been wired to a Pattern Generator.

Program Segment 1	Program Segment 2	Program Segment 3	Program Segment x
User Value 1 Value 1	User Value 1 Value 6	User Value 1 Value 11	User Value 1 Value 15
Pattern Generator output 1	Pattern Generator output 6	Pattern Generator output 11	Pattern Generator output 15

In each segment a different pattern of digital outputs is set up from the single value set in the User Value for each segment.

7.3.1 Program User Value Enumerations

Each program user value may be allocated a name chosen from 'User Text' library. This means that a name can be allocated to Value 1 to Value x in the above table, and can be used to describe the functions carried out in each segment. For example, if User Value 1 is called 'Carburise' the Pattern Generator will set the digital pattern required for carburising and this message can be made to appear in the PATTERN GEN (Dig Group x) page during that segment.

An example which shows how to apply an Enumeration to a Programmer User Value is given in Chapter 14.

7.4 PROGRAMMER TYPES

The programmer can be configured as **Time to Target** or **Ramp Rate**. A time to target programmer requires fewer settings and is simple to use since all segments are the same. A time to target programmer can, in general contain more segments than a ramp rate.

7.4.1 Time To Target Programmer

Each segment consists of a **single duration parameter** and a set of **target values** for the profiled variables.

1. The **duration** specifies the time that the segment takes to change the profiled variables from their current values to the new targets.
2. A **dwll** type segment is set up by leaving the target setpoint at the previous value.
3. A **Step** type segment is set up by setting the segment time to zero.

7.4.2 Ramp Rate Programmer

Each segment can be specified by the operator as **Ramp Rate, Dwell or Step**.

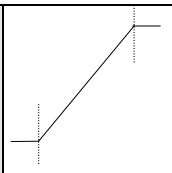
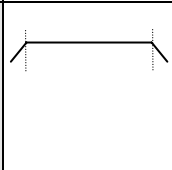
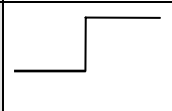
1. Each profiled setpoint must complete its segment before the programmer will move to the next segment. If one ramp reaches its target setpoint ahead of the other variables, it will dwell at that value until the other variables have completed. The program will then move to the next segment.
2. The duration parameter for a segment is read only unless the segment contains only dwells. In this case the dwell period can be changed when the program is in Hold..
3. The duration is determined by the longest profile setting.

7.5 SEGMENT TYPES

A segment type can be defined as **Profile, Go Back** or **End**.

7.5.1 Profile

A profile segment may be set as:-

<p>Ramp</p> 	<p>The setpoint ramps linearly, from its current value to a new value, either at a set rate (called ramp-rate programming), or in a set time (called time-to-target programming). You must specify the ramp rate or the ramp time, and the target setpoint, when creating or modifying a program.</p>
<p>Dwell</p> 	<p>The setpoint remains constant for a specified period at the specified target. When creating programs the target is inherited from the previous segment. When editing an existing program it is necessary to re-enter the target value. This allows the dwell target to be matched to a go-back segment.</p>
<p>Step</p> 	<p>The setpoint steps instantaneously from its current value to a new value at the beginning of a segment.</p>

7.5.2 Go Back Segment

Go Back allows segments in a program to be repeated by a set number of times. It is the equivalent of inserting 'sub-programs' on some controllers. Figure 6-4 shows an example of a program which is required to repeat the same section a number of times and then continue the program.

A Go Back segment is used to save the total number of segments required in a program and to simplify setting up. When planning a program it is advisable to ensure that the end and start setpoints of the program are the same otherwise it will step to the different levels. A Go Back segment is defined when editing a program.

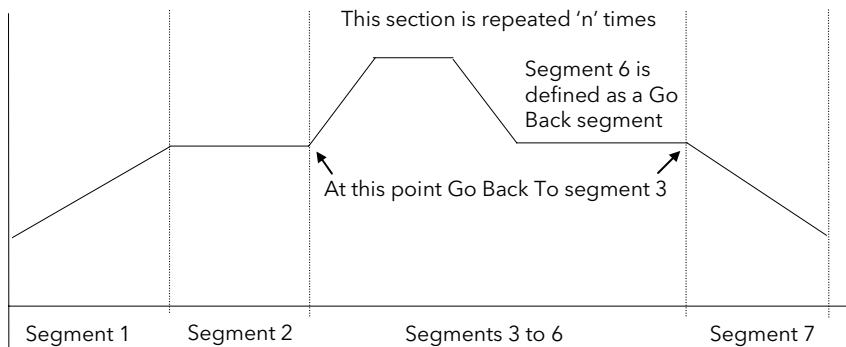


Figure 7-4: An Example of a Program with Repeating Section

Note 1. If a second or more 'Go Back' segments are created, they cannot return to a segment before the previous 'Go Back' segment as shown below.

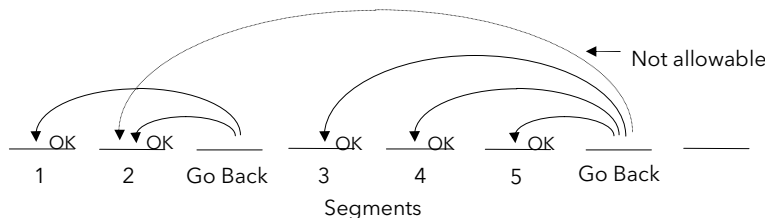


Figure 7-5: Permitted Go Back Segments

7.5.3 End Segment

The last segment in a program is normally defined as an End segment

The program either ends, repeats or resets in this segment. You specify which is the case when you create, or modify, the program. When the program ends, the programmer is put into either, a continuous dwell state with all outputs staying unchanged, or the reset state.

7.6 TO ENABLE THE PROGRAMMER FUNCTION BLOCK

If the instrument has been supplied as a programmer it will only be necessary to complete this step if the programmer feature has subsequently been disabled.

In configuration level:-

Do This	This Is The Display You Should See	Additional Notes
1. Select INSTRUMENT (Options Page)		
2. Press to select Num of Loops		1, 2 or 3 loops can be selected if the option has been supplied
3. Press or to select the required number of loops		
4. Press to select Programmer		If the Programmer is set to Disabled the Programmer pages do not appear.
5. Press or to select Enabled		


7.7 TO CONFIGURE PROGRAM TYPE

The programmer is supplied as a **Time to Target** programmer. This section describes how to configure a **Ramp Rate** type.

In configuration level:-

Do This	This Is The Display You Should See	Additional Notes
1. From any display press as many times as necessary to select PROGRAM EDIT (Options Page)		
2. Press to select Program Type		The Program Type may be:- Time to Target - Each segment is a single duration. Or Ramp Rate - Segments are Ramp, Dwell or Step. Time to Target is the default
3. Press or to select Time to Target or Ramp Rate		If programs have already been set up using the previous Program Type all segment data will be deleted and will need to be re-entered in Operation level.
4. Press to select confirm		The Program Type requires a few seconds to re-configure during which time 'INITIALISING' is displayed. The Program Type is then confirmed The table on the next page lists all parameters in the Options page. Press to select each parameter in turn. If the parameter is preceded by , press to change its value.

7.7.1 PROGRAM EDIT Options Page

Table Number: 6.7.1. These parameters allow you to configure Program Type and Options		PROGRAM EDIT (Options Page)	
Parameter Name Press  to select	Parameter Description	Value	Default
Program Type	Programmer type	Time to Target Ramp Rate	
Num of PSPs	Number of programmer setpoints	1, 2 or 3	
Prog Usr Val1?	Enables user value 1	No Yes	No
<i>UVal1</i> Low Lim ⁽¹⁾	User value 1 low limit	0 to 100 limited by UVal1 Hi Lim	Only shown if Prog Usr Val1 = Yes
<i>UVal1</i> Hi Lim ⁽¹⁾	User value 1 high limit	0 to 100	
Usr Val1 Name ⁽¹⁾	Name from user text for programmer user value 1	01:Usr1 to 50:Usr50	Default text
Usr Val1 Enum ⁽¹⁾	First user string from for programmer user value 1 custom enumeration	01:Usr1 to 50:Usr50	Default Text
Prog Usr Val2?	Enables user value 2	No Yes	No
<i>Uval2</i> Low Lim ⁽¹⁾	User value 2 low limit	0 to 100 limited by Uval2 Hi Lim	Only shown if Prog Usr Val2 = Yes
<i>Uval2</i> Hi Lim ⁽¹⁾	User value 2 high limit	0 to 100	
Usr Val2 Name ⁽¹⁾	Name from user text for programmer user value 2	01:Usr1 to 50:Usr50	Default text
Usr Val2 Enum ⁽¹⁾	First user string from for programmer user value 2 custom enumeration	01:Usr1 to 50:Usr50	Default Text
Wait Events?	Activates the Wait events option	No Yes	
Hot Start	Activates the hot start option	No Yes	
Recovery Type	Defines the power recovery strategy	Ramp Back Reset Continue	Continue
Reset Time	Power recovery reset time (Only if 'Recovery Type' = 'Test Time')	0:00:00 to 23:59:59	
Servo Time	Power recovery servo time (Only if 'Recovery Type' = 'Test Time')	0:00:00 to 23:59:59	
Num of Prg DOs	Defines the number of digital event outputs used	None to 16	
<i>PSP1</i> Units	Units to be displayed for PSP1	See Appendix D.2.	
<i>PSP1</i> Resol	PSP1 decimal point resolution	XXXXX XXXX.X XXX.XX XX.XXX	
<i>PSP1</i> Low Lim	PSP1 low limit	Display range	
<i>PSP1</i> High Lim	PSP1 high limit	Display range	
<i>PSP1</i> Reset Val	Safe state target setpoint	Prog SP lo lim to Prog SP hi lim	
PSP1 Name	To choose a name for PSP1 from user text	Default Text to 50:User50	Default Text
The above parameters are repeated for PSP2 and PSP3 if these have been configured using Num of PSPs			
Profile Lock	Prevents a program from being selected See also section 6.8. below	Unlocked Profile Locked Fully Locked	
Mimic Page	The program mimic page may be turned off or configured to appear in the Main Menu or in the Summary Page	Off Main Page Summary Page	

Note (1) - Parameters only available if the relevant User Value = 'Yes'

7.8 PROFILE LOCK

Profile Lock is a configuration parameter which allows programs to be created but which prevents them from being changed in operation levels.

If more than one program was created prior to 'Profile Lock' being selected, then the user can select these programs (using 'Program Number') but cannot create any more.

The options are:-

Fully Locked	No parameter or the profile can be changed in operation levels
Profile Locked	The profile of the program is locked but changes can be made to certain parameters such as Target setpoints, rates, dwells or segment duration.

7.9 PROGRAMMER WIRING

7.9.1 Programmer Function Block

The programmer function block, below, shows an example of soft wiring to other functions.. The connections can be made using the copy and paste method described in section 3.1.2. with the exception of the Prg.DO1 to Prg.DO16 event outputs. These can be found by searching through the list of parameters or by entering the Modbus address directly. The Modbus addresses for these parameters are 05869 to 05883 inclusive.

The parameters which can be wired are listed in Table 6.9.2.. These parameters can be wired to any other parameter by Modbus address or using the shorter list of parameter names

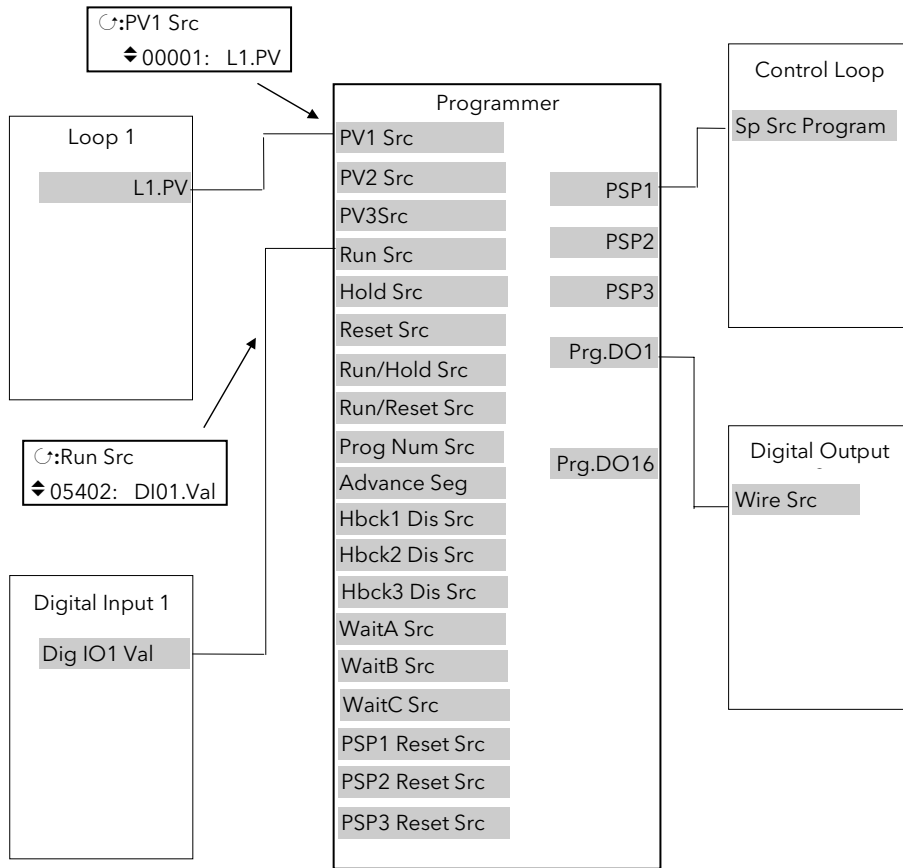



Figure 7-6: Programmer Function Block and Wiring Example

7.9.2 PROGRAM EDIT Wiring Page

Table Number: 6.9.2.		These parameters allow you to soft wire programmer functions	PROGRAM EDIT (Wiring Page)
Parameter Name Press  to select	Parameter Description	Default Wiring Value Modbus Address:Parameter Mnemonic	
PV1 Src	PV 1 source	00001:LP1 PV	
PV2 Src	PV 2 source	01025:LP2 PV	
PV3 Src	PV 3 source	02049:LP3 PV	
Prog Num Src	Program number source	Not wired by default	
Run Src	Run source	05494:DIO5	
Hold Src	Hold Source	05642:DIO6	
Reset Src	Reset Source	05690:DIO7	
Run/Hold Src	Run/Hold Source	Not wired by default	
Run/Reset S	Run/Reset Source	Not wired by default	
Advanc Prog	Advance Program source	Not wired by default	
Advanc Seg	Advance segment source	12609:DI8	
FineHbck1 Sr	Fine holdback 1 source	Not wired by default	
CorseHbck1	Course holdback 1 source	Not wired by default	
Hbck1 Dis Src	Holdback 1 disable source	Not wired by default	
FineHbck2 Sr	Fine holdback 2 source	Not wired by default	
CorseHbck2	Course holdback 2 source	Not wired by default	
Hbck2 Dis Src	Holdback 2 disable source	Not wired by default	
FineHbck3 Sr	Fine holdback 3 source	Not wired by default	
CorseHbck3	Course holdback 3 source	Not wired by default	
Hbck3 Dis Src	Holdback 3 disable source	Not wired by default	
WaitA Src	Wait A source	Not wired by default	
WaitB Src	Wait B source	Not wired by default	
WaitC Src	Wait C source	Not wired by default	
PSP1 Reset Src	PSP1 reset source ⁽¹⁾	00001:LP1 PV	
PSP2 Reset Src	PSP2 reset source ⁽¹⁾	01025:LP2 PV	
PSP3 Reset Src	PSP3 reset source ⁽¹⁾	02049:LP3 PV	

Note 1:- The PSP Reset Source defines the programmer starting conditions. To servo to setpoint, wire the relevant reset source into the SP. To servo to PV, wire the relevant reset source into the PV.

The value which is wired into the Reset Source is the value which appears at the programmer output.

7.10 TO CREATE OR EDIT A PROGRAM

A program can be created or edited in any access level (unless the list has been hidden).

1. First define the parameters associated with the overall program. These parameters will be found under the page header **'PROGRAM EDIT (Program)'**
2. Then set up the parameters which define each individual segment. These parameters will be found in the page **'PROGRAM EDIT (Segments)'**



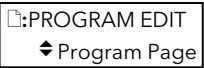


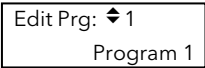





The procedure is described in the following sections and in the 2604 User Guide

Notes:-

1. A running program cannot be edited, it must be put into **Reset** or **Hold** mode.
2. Changes can be made to any segment of a currently running program as follows:-
 - To the currently running segment - use the PROGRAM RUN page. These changes are always temporary and apply to the current run only
 - To any segment - use the PROGRAM EDIT page. These changes are always permanent and will apply to subsequent runs.
3. Other programs can be created or edited when another program is running.

7.10.1 Parameters Common To A Program

To set up parameters common to a program:-

Do This	This is the Display You Should See	Additional Notes
1. From the PROGRAM EDIT press  or  to select 'Program Page'		
2. Press  to select the first parameter 'Edit Prg:  1'		The text <i>Program 1</i> may be a user defined name from User Text The following table lists further parameters in this page. Press  to select each parameter in tune. If the parameter is preceded by  , press   to change its value 

7.10.2 PROGRAM EDIT Program Page




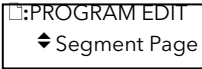

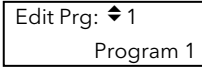




Table Number: 6.10.2		These parameters affect the overall program.			PROGRAM EDIT (Program Page)
Parameter Name	Parameter Description	Value	Default	Access Level	
Edit Prg:  1	Selects the program number to be edited. If 'Profile Lock' ≠ 'Unlocked', only those programs which were created prior to setting the 'Profile Lock' parameter can be selected.	1 to 20 or 1 to 50	<i>Program 1</i> Name may be chosen from User Text	L1	
Hbk Mode	Holdback mode None = no holdback Per prog = applied over the whole program Per seg = active in every segment	None Per Program Per Segment	None	L1	
<i>PSP1</i> Hbk Type	Holdback type for <i>PSP1</i> (per program) These are deviations between SP and PV Fine and course holdback allows two levels of holdback to be applied to different segments, see also section 6.2.10.	Off Fine Lo Fine Hi Fine Band Course Lo Course Hi Course Band	Off	L1 Only displayed if Per Program configured	

Table Number: 6.10.2		These parameters affect the overall program.		PROGRAM EDIT (Program Page)	
Parameter Name	Parameter Description	Value	Default	Access Level	
PSP1 FineHbk	Fine holdback value for PSP1	Display Range	0	L3. Only shown if 'HBk Mode' ≠ Off	
PSP1 CourseHbk	Course holdback value for PSP1	Display Range	0		
The above three parameters are repeated for PSP2 and for PSP3 if these are configured					
Hot Start PSP	Allows hot start to be applied to each PSP. See also section 6.2.5.	None PSP1 PSP2 PSP3	None	L1	
Rate Units	Rate units for a Ramp Rate Programmer	Per Second Per Minute Per Hour		L3. Only displayed if the programmer is Ramp Rate	
Program Cycles	The number of times a program repeats.	Cont. to 999	Cont.	L1	
End Action	Defines the action in the end segment. Dwell - the program will dwell indefinitely at the conditions set in the end segment. Reset - the program will reset to the start conditions.	Dwell Reset		L1	
Program Name	Allows a user defined name to be given to the program number	User string Each character can be set in turn		L1	

7.10.3 Parameters Common To Each Segment

To set up each segment:-

Do This	This is the Display You Should See	Additional Notes
1. From the PROGRAM EDIT press  or  to select ' Segment Page '		
2. Press  to select the first parameter ' Edit Prg: ◆ 1 '		The text <i>Program 1</i> may be a user defined name from User Text The following table lists further parameters in this page. Press  to select each parameter in tune. If the parameter is preceded by ◆, press   to change its value 

7.10.4 PROGRAM EDIT Segment Page


Table Number: 6.10.4.		These parameters allow you to set up each segment in the program		PROGRAM EDIT (Segment Page)	
Parameter Name	Parameter Description	Value	Default	Access Level	
Edit Prg: ◆ 1 (to 20 or 50)	Selects the program number and name	1 to 20 (or 50)		L1	
Segment Number	Selects the segment number to be edited	1 to 100		L1	
Segment Type	Segment type Profile = a normal segment End Segment = the last segment in the program (press  to confirm) Go Back = repeat part of prog. Not shown for segment 1.	Profile End Segment Go Back	Profile	L1	

Table Number: 6.10.4. These parameters allow you to set up each segment in the program		PROGRAM EDIT (Segment Page)		
Parameter Name	Parameter Description	Value	Default	Access Level
<i>PSP1</i> Type	Profile setpoint 1 type	Step Dwell Ramp		L1. Only shown for Ramp Rate programmer and not End
<i>PSP1</i> Target	Profile setpoint 1 target value	SP1 lo limit to SP1 hi limit	0	L2
<i>PSP1</i> Dwell Tm	Profile setpoint 1 dwell time	d : h : m : s		L1. Only shown for Ramp Rate programmer a Dwell segment and not End
<i>PSP1</i> Rate	Profile setpoint 1 rate			L2. Only shown for Ramp Rate programmer a ramp segment and not End
<i>PSP1</i> Hbk Type	Profile setpoint 1 holdback type	Off Fine Lo Fine Hi Fine Band Course Lo Course Hi Course Band	Off	L2. Only shown if 'Hbk Mode' is configured per segment
The above five parameters are repeated if <i>PSP2</i> and <i>PSP3</i> are configured				
Seg Duration	Duration for Time to Target programmer	d : h : m : s		L2. Does not appear for Ramp Rate Programmer or End segment
Wait Event	Wait if selected event is true	No wait Event A Event B Event C	No Wait	L2. Only shown if 'Wait Events' configured
Prog User Val 1	Allows a programmer user value to be chosen. See also section 6.3.	0 - 100	0	L1. Only shown if 'Prog User Val 1' is configured
Prog User Val 2	Allows a programmer user value to be chosen. See also section 6.3.	0 - 100	0	L1. Only shown if 'Prog User Val 2' is configured
PID Set	Selects a set of PID values	PID Set 1 to PID Set 3		L2. Only shown if 'PID sets' configured
Prog DO Values	Sets programmer event outputs on or off <input type="checkbox"/> <input type="checkbox"/> <input type="checkbox"/> <input type="checkbox"/> <input type="checkbox"/> <input type="checkbox"/> <input type="checkbox"/> <input type="checkbox"/> <input type="checkbox"/> <input type="checkbox"/> <input type="checkbox"/> <input type="checkbox"/> <input type="checkbox"/> <input type="checkbox"/> <input type="checkbox"/> <input type="checkbox"/> depends on number of events configured in PROGRAM (Options Page)	<input type="checkbox"/> = Off <input checked="" type="checkbox"/> = On	<input type="checkbox"/>	L2. Only shown if 'Num of Prg DOs' is configured
Go Back Seg	Go back defines the point in the program where the repeat segments are entered.	1 to no. of segments		L2. Only shown if segment. type is 'Go Back'
Go Back Cycles	Sets up the number of times the segments are repeated	1 to 999	1	

7.10.5 Run Parameters

The Run list appears differently depending on the access level.

A program will only run when the controller is in operation levels 1, 2 or 3. If a program is running and the controller is put into Configuration level the program will reset.

The first set of tables below show the parameters which appear in levels 1, 2 or 3.

The second set of tables show the parameters when in configuration level.


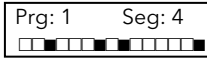
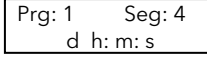
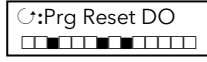
Table Number: 6.10.5a.		These parameters show the overall status of a running program		PROGRAM RUN (General Page)	
Parameter Name	Parameter Description	Value	Default	Access Level	
These displays may be promoted by the user as an over-view of the program status		Program Number Segment Number Program Name		R/O	
		Digital outputs states. Only appears if digital outputs are configured		L1. Can be changed in Hold	
		Program Time Remaining			R/O
Fast Run	Allows the program to fast run (X10)	No Yes		L3. Alterable in reset or complete	
Program Status	Displays the status of the program	Reset Run Hold Complete		L1.	
Prog Time Elap	Program time elapsed	d: h: m: s		R/O	
Prog Cycle Rem	Remaining number of cycles	1 to 999		R/O	
Total Segments	Number of segments in the running program	0 to 100		R/O	
Segment Number	The currently running segment number	1 to 100		R/O	
Segment Type	Running program segment type Profile = normal segment Go Back = repeat part of prog	Profile End Segment Go Back		R/O	
Seg Time Rem	Time remaining in the current segment	d: h: m: s		L1. Read or alterable if Time To Target prog and in Hold	
Wait Status	Wait Status	No Wait Event A Event B Event C		R/O	
Wait Condition	Wait condition for the running segment	No Wait Event A Event B Event C		L1. Alterable in Hold	
PID Set	PID values used in running program	PID Set 1 to PID Set 3		R/O - Only shown if configured	
Goback Rem	Number of repeat cycles remaining	1 to 999		R/O	
End Action	The state required in the end segment	Dwell Reset		R/O	
Prog Reset DO	These are the digital events in Reset 			R/O Only shown if configured.	

Table Number: 6.6.5b. These parameters refer to Profiled Setpoint number 1 for a running program. Repeated for PSP2 and PSP3		PROGRAM RUN (PSP1 Page)		
Parameter Name	Parameter Description	Value	Default	Access Level
Seg Time Rem	Segment time remaining	h: m: s		
PSP1 Type	Running segment type for profiled setpoint 1	Step Dwell Ramp		R/O - shown in Ramp Rate prog.
PSP1 WSP	Working setpoint for profiled setpoint 1	Display range ¹		L1. Alterable in Hold
PSP1 Target	Running segment target for profiled setpoint 1	Display range ¹		L1. Alterable in Hold
PSP1 Dwell Tm	Time remaining in running segment for profiled SP 1	Display range		L1. Alterable in Hold
PSP1 Rate	Running segment rate for profiled setpoint 1	Display range ¹		L1. Not in Time To Target prog
PSP1 HBk Appl	Holdback applied for profiled setpoint 1	No Yes		R/O - shown if configured

¹ Range limited by user defined upper and lower limits

Table Number: 6.10.5c. These parameters are displayed when the controller is in configuration level		PROGRAM RUN (General Page)		
Parameter Name	Parameter Description	Value	Default	Access Level
State of programs 1 to 50				Conf
State of digital outputs in program 1				Conf
State of program 1				Conf
Fast Run	Allows the program to fast run	No Yes	No	Conf
Program Status	Displays the status of the program	Reset Run Hold Complete		Conf
Prog Run	Programmer run status wire source	1 = running		Conf
Prog Hold	Programmer hold status wire source	1 = holding		Conf
Prog Reset	Programmer reset status wire source	1 = reset		Conf
Prog End	Programmer end status wire source	1 = end		Conf
New Seg	New segment wire source	1 = new segment for 100ms		Conf
Prog Time Elap	Program time elapsed	h: mm: ss		Conf
Prog Cycle Rem	Remaining number of cycles	1 to 999		Conf
Total Segments	Number of segments in the running program	0 to 100		Conf
Segment Number	The currently running segment number	1 to 100		Conf
Segment Type	Running program segment type Profile = normal segment End Segment = End of prog Go Back =repeat part of prog	Profile End Segment Go Back	Profile	Conf
Seg Time Rem	Time remaining in the current segment	d: h: m: s		Conf
Wait Status	Wait Status	No Wait	No Wait	Conf

Table Number: 6.10.5c		These parameters are displayed when the controller is in configuration level		PROGRAM RUN (General Page)	
Parameter Name	Parameter Description	Value	Default	Access Level	
		Event A Event B Event C			
Wait Condition	Wait condition for the running segment	No Wait Event A Event B Event C	No Wait	Conf	
Prog User Val 1	Active Programmer User Val 1			Conf	
Prog User Val 2	Active Programmer User Val 2			Conf	
Goback Rem	Number of repeat cycles remaining	1 to 999		Conf	
End Action	The state required in the end segment	Dwell Reset		Conf	
Prog Reset DO	These are the digital events in Reset □□■□□□■□□□□□□□			Conf Only shown if configured.	
Reset UsrVal1	Reset prog user 1 values			Conf	
Reset UsrVal1	Reset prog user 1 values			Conf	

Table Number: 6.10.5d		These parameters are associated with Profiled Setpoint number 1 Repeated for PSP2 and PSP3		PROGRAM RUN (PSP1 Page)	
Parameter Name	Parameter Description	Value	Default	Access Level	
Seg Time Rem	Segment time remaining	h: m: s		Conf R/O	
PSP1 Type	Running segment type for profiled setpoint 1	Step Dwell Ramp		Conf R/O - shown in Ramp Rate prog.	
PSP1 WSP	Working setpoint for profiled setpoint 1	Display range ¹		Conf R/O	
PSP1 Target	Running segment target for profiled setpoint 1	Display range ¹		Conf R/O	
PSP1 Dwell Tm	Time remaining in running segment for profiled SP 1	Display range		Conf R/O	
PSP1 Rate	Running segment rate for profiled setpoint 1	Display range ¹		Conf R/O Not in Time To Target prog	
PSP1 HBk Appl	Holdback applied for profiled setpoint 1	No Yes		Conf R/O shown if configured	

1. Range limited by user defined upper and lower limits.

7.11 PROGRAMMER WIRING EXAMPLES

7.11.1 One Profile, Three Loops

This example explains how to configure a programmer to allow one profile to generate a setpoint for three control loops.

The 2604 program block can generate up to three profiled variables, which can then be internally wired to any parameter source. In most cases the PSPs are used to allow control loop setpoints to follow a pre-determined ramp/dwell sequence, but they can also be used, for example, to retransmit a setpoint to a slave device.

In this example PSP1 is soft wired to the program setpoints of each control loop. Also, the PV of loop1 is wired to the PV1 source, to provide holdback, and the PSP1 reset source, to provide servo start. This configuration is supplied from the factory by defining the hardware code field, in the 2604 order code, for loops/programs to be '321' or '351'.

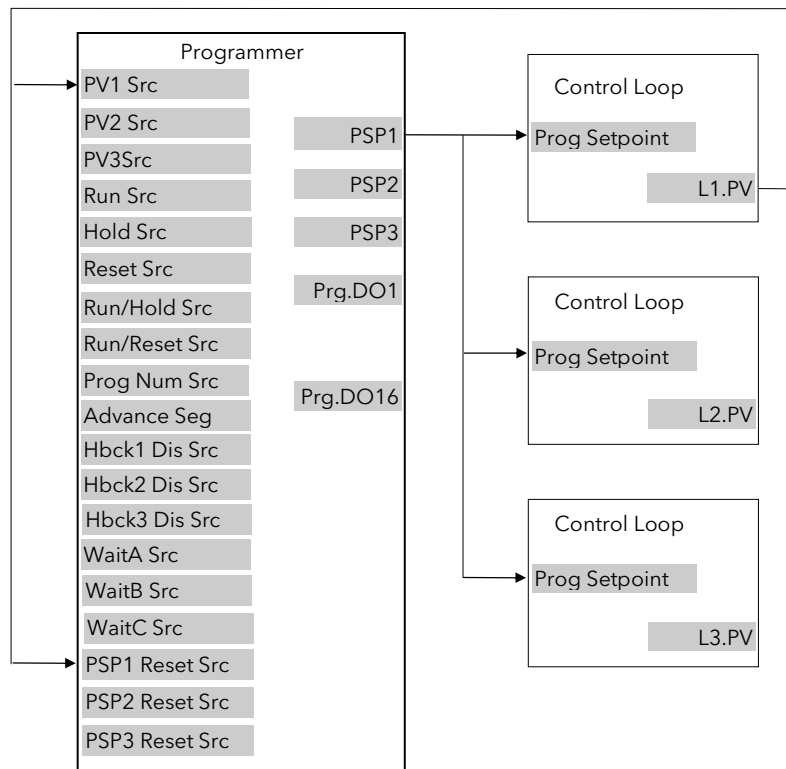



Figure 7-7: Example Programmer Wiring One Profile Three Loops

7.11.1.1 Implementation

1. In INSTRUMENT/Options Page set 'Num of Loops' = 3
set 'Programmer = Enabled'
2. In PROGRAM EDIT/Options Page set 'Num of PSPs' = 1
(Note: other parameters such as number of digital event outputs, SP range and power failure recovery are also set in this page)
3. In PROGRAM EDIT/Wiring Page Set 'PV1 Src' = 00001:L1.PV
This connection is required so that the programmer can use Loop 1 PV to calculate holdback.
4. In PROGRAM EDIT/Wiring Page Set 'PSP1 Reset Src' = 00001:L1.PV
This connection is required so that the programmer can use Loop 1 PV to servo start.
5. In LP1 SETUP/Options Page Set 'Prog Setpoint' = PSP1
Connects PSP1 to become the program SP for Loop 1
6. In LP2 SETUP/Options Page Set 'Prog Setpoint' = PSP1
Connects PSP1 to become the program SP for Loop 2
7. In LP3 SETUP/Options Page Set 'Prog Setpoint' = PSP1
Connects PSP1 to become the program SP for Loop 3

See Appendix D for list of Modbus addresses.

 **Tip:-** See 'Copy and Paste' description in Chapter 3.

7.11.2 Two Profiles, Two Loops

This example explains how to configure a 2604 programmer to generate two setpoints which are then used to profile the setpoint for two independent control loops.

In this example PSP1 and PSP2 are soft wired to the program setpoints of loop 1 and loop 2 respectively. Also, the PV of loop1 is wired to the PV1 source, to provide holdback, and the PSP1 reset source, to provide servo start. The latter is repeated for Loop 2. This configuration is supplied from the factory by defining the hardware code field, in the 2604 order code, for loops/programs to be '222' or '252'.

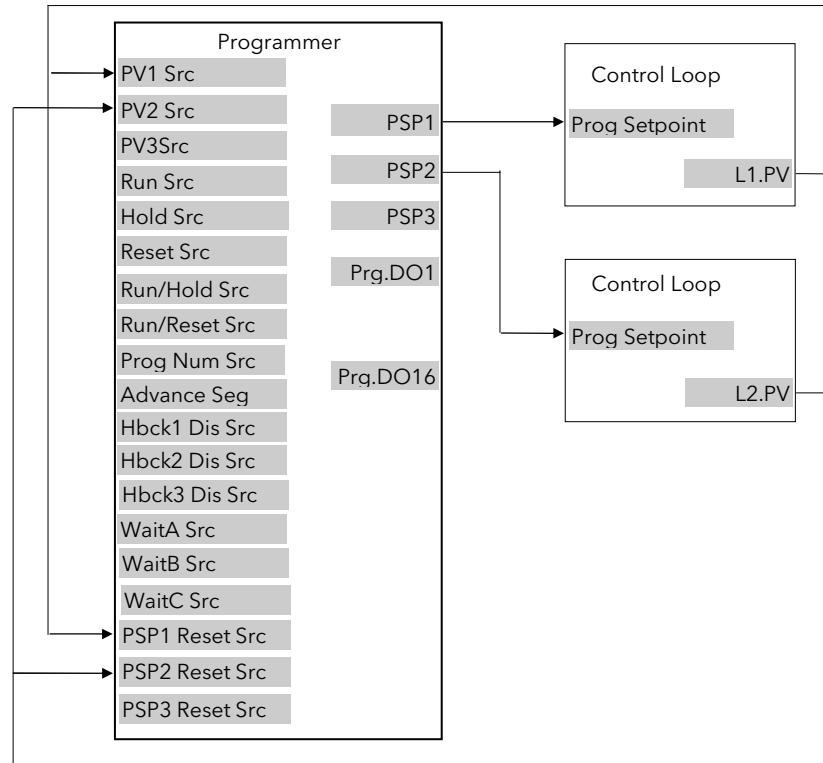


Figure 7-8: Example Programmer Wiring Two Profiles Two Loops

7.11.2.1 Implementation

1. In INSTRUMENT/Options Page set 'Num of Loops' = 2
set 'Programmer = Enabled'
2. In PROGRAM EDIT/Options Page set 'Num of PSPs' = 2
(Note: other parameters such as number of digital event outputs, SP range and power failure recovery are also set in this page)
3. In PROGRAM EDIT/Wiring Page Set 'PV1 Src' = 00001:L1.PV
This connection is required so that the programmer can use Loop 1 PV to calculate holdback for PSP1.
4. In PROGRAM EDIT/Wiring Page Set 'PV2 Src' = 01025:L2.PV
This connection is required so that the programmer can use Loop 2 PV to calculate holdback for PSP2.
5. In PROGRAM EDIT/Wiring Page Set 'PSP1 Reset Src' = 00001:L1.PV
This connection is required so that PSP1 can use Loop 1 PV to servo start.
6. In PROGRAM EDIT/Wiring Page Set 'PSP2 Reset Src' = 01025:L2.PV
This connection is required so that PSP2 can use Loop 2 PV to servo start.
7. In LP1 SETUP/Options Page Set 'Prog Setpoint' = PSP1
Connects PSP1 to become the program SP for Loop 1
8. In LP2 SETUP/Options Page Set 'Prog Setpoint' = PSP2
Connects PSP2 to become the program SP for Loop 2

See Appendix D for list of Modbus addresses.

☺ **Tip:-** See 'Copy and Paste' description in Chapter 3.

8. CHAPTER 7 DIGITAL PROGRAMMER

8.1 WHAT IS THE DIGITAL PROGRAMMER?

The digital programmer provides a timed control of a single digital output. It may be used during any segment of a Setpoint Programmer or it may be used independently of the Setpoint Programmer.

A sequence of eight Off and On times may be set for the output and up to four Digital Programs can be set. Figure 7-1 shows an example of a timed digital output program.

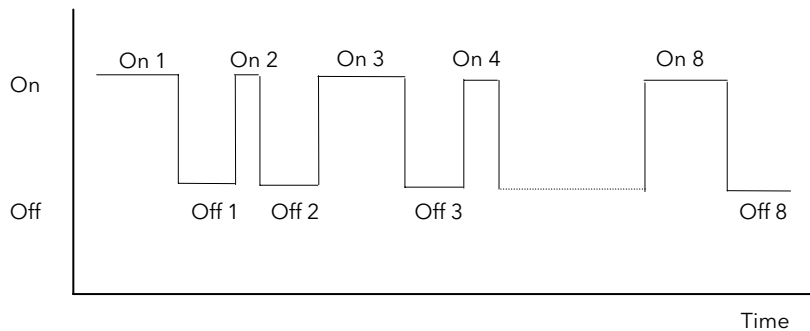





















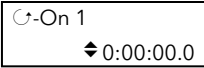






Figure 8-1: An Example of a Programmed Digital Output

Step	Time	Description
On 1	1:00:00.0	On starting the sequence the output will be ON for 1 hour
Off 1	0:30:00.0	The output switches OFF for 30 minutes
On 2	0:05:00.0	The output switches ON for 5 minutes
Off 2	0:30:00.0	The output switches OFF for 30 minutes
On 3	1:00:00.0	The output switches ON for 1 hour
Off 3	0:25:00.0	The output switches OFF for 25 minutes
On 4	0:10:00.0	The output switches ON for 10 minutes
Off 4	0:00:00.0	
On 5	0:00:00.0	
Off 5	0:00:00.0	The step is omitted for any time set to zero
On 6	0:00:00.0	
Off 6	0:00:00.0	
On 7	0:00:00.0	
Off 7	0:00:00.0	
On 8	1:10:00.0	The output switches ON for 1 hour 10 minutes
Off 8	0:40:00.0	The output switches OFF for 40 minutes and is then reset to the start of the sequence


The sequence may be run by:

1. Setting the 'Prog Status' parameter to 'Run'
2. Wiring the 'Run/Hold Src' to:
 - a. A digital input controlled an external source such as a push-button
 - b. A programmer 'User Value'

8.2 TO EDIT THE DIGITAL PROGRAMMER

Do This	This Is The Display You Should See	Additional Notes
1. From any display press  to select 'DIGITAL PROG' 2. Press  or  to select 'Edit Program' if necessary		
3. Press  to select the first parameter in the list. This is 'Prog Hi Limit' 4. Press  or  to set an upper limit on the number of programs required		Up to four digital programs can be chosen; 0, 1, 2, or 3
5. Press  again to select 'Prog Select' 6. Press  or  to change the program number if required		Up to four digital programs can be chosen; Prog 1 Prog 2 Prog 3 Prog 4
7. Press  to select 'Prog Enum' 8. Press  or  to choose an enumeration		The name of the program can be chosen from User Values
9. Press  to select 'On 1' 10. Press  or  to increase or decrease the on time for the first output in the sequence 11. Repeat for the eight On and Off periods which make up the sequence		Tip  To enter a large time period press  and  together. This will underline the mins and hours sections independently each time the se buttons are pressed. The hours/mins can then be raised or lowered using  or  only. The full list of parameters is shown in the following table 

8.2.1 Digital Program Edit Page

Table Number: 7.2.1. These parameters edit the digital programmer		DIGITAL PROG (Edit Program Page)		
Parameter Name Press  to select	Parameter Description	Value	Default	Access Level
Prog Hi Limit	Program select upper limit	0 to 3		L3
Prog Select	Program select	Prog 1 to Prog 4		L3
Prog Enum	User string for first custom enumeration	Not enumerated Usr01 to Usr 50	Not enumerated	L3
On 1	On period 1	0:00:00.0 to 99:59:59.9 If this setting is exceeded HHHH is displayed. To reduce the value Press	0:00:00.0	L3
Off 1	Off period 1		0:00:00.0	L3
On 2	On period 2		0:00:00.0	L3
Off 2	Off period 2		0:00:00.0	L3
On 3	On period 3		0:00:00.0	L3
Off 3	Off period 3		0:00:00.0	L3
On 4	On period 4		0:00:00.0	L3
Off 4	Off period 4		0:00:00.0	L3

On 5	On period 5	and hold ▼ button	0:00:00.0	L3
Off 5	Off period 5		0:00:00.0	L3
On 6	On period 6		0:00:00.0	L3
Off 6	Off period 6		0:00:00.0	L3
On 7	On period 7		0:00:00.0	L3
Off 7	Off period 7		0:00:00.0	L3
On 8	On period 8		0:00:00.0	L3
Off 8	Off period 8		0:00:00.0	L3

8.2.2 Digital Program 1 to 4 Page

Table Number: 7.2.2. These parameters are associated with Digital Programs 1 to 4		DIGITAL PROG (Dig Prog x Page)		
Parameter Name	Parameter Description	Value	Default	Access Level
Reset Src	Reset wire source	Modbus address	None	Conf
Run/Hold Src	Run/Hold (equivalent to Prog Status) wire source	Modbus address	None	Conf
OP Enable Src	Output wire source	Modbus address	None	Conf
Reset Disable	When Reset Disable = Off the program is in reset	Off On	Off	L3
Prog Status	Program status	Hold Run		L3
OP Enable	Enables the output	Off On	Off	L3
Reset on PFail	Power fail recovery see 7.3	Off On	Off	L3
Program Cycles	Number of cycles for the sequence	Continuous to 999	Continuous	L3
Seg Time Rem	Segment time remaining	0:00:00.0 to 99:59:59.9		L3
Output	Shows the current state of the output	Off On		L3
Output (Inv)	Shows the current inverted state of the output	Off On		L3
Prg End	Program complete Off = prog running` On = prog complete	Off On		L3 R/O

8.3 POWER FAIL RECOVERY

In the event of a power fail to the controller, the parameter, 'Reset on PFail', defines how the controller behaves on restoration of the power.

If this parameter = 'On' then 'Prog Status' = 'Hold' and 'Reset Disable' = 'Off' at power up.

If Prog Status and Reset Disable have been soft wired they override this state.

9. CHAPTER 8 ALARM CONFIGURATION

9.1 DEFINITION OF ALARMS AND EVENTS

Alarms are used to alert an operator when a pre-set level or condition has been exceeded. They are normally used to switch an output - usually a relay - to provide interlocking of the machine or plant or external audio or visual indication of the condition.

Soft Alarms are indication only within the controller and are not attached to an output (relay).

Events - can also be alarms - but are generally defined as conditions which occur as part of the normal operation of the plant. They do not generally require operator intervention. An example might be to open/close a vent during a programmer cycle.

The controller does not display the alarm status on the front panel.

For the purposes of the operation of this controller, alarms and events can be considered the same.

9.1.1 Customisable Parameter Names

Throughout this chapter parameter names shown in *italics* are customisable by the user. The name of the parameter may vary, therefore, from instrument to instrument.

Typical customisable parameter names are:

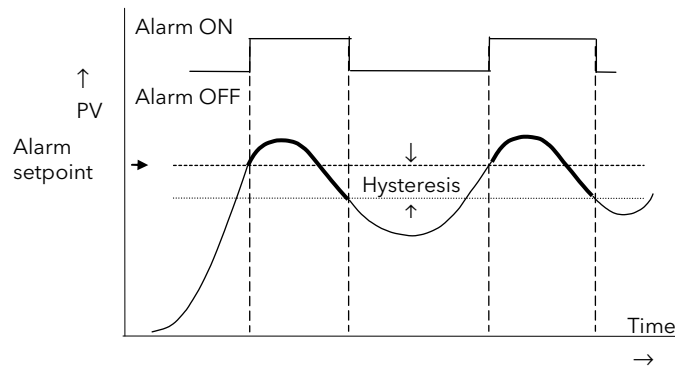
- Alarm names
- Loop names
- Module and Input names
- Custom units
- Promoted parameters

9.2 TYPES OF ALARM USED IN 2604 CONTROLLER

This section describes graphically the operation of different types of alarm used in the 2604 controller. The graphs show measured value plotted against time. The measured value may be any analogue value available in the controller.

9.2.1 Full Scale High

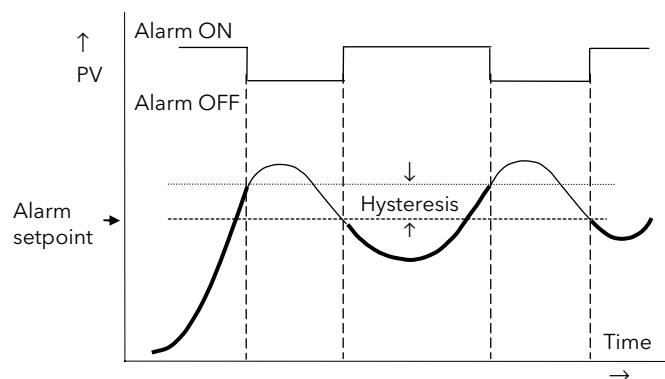
The Process Variable (PV) exceeds a set high level



Hysteresis is the difference between the alarm ON value and the alarm OFF value. It is used to prevent relay chatter.

9.2.2 Full Scale Low

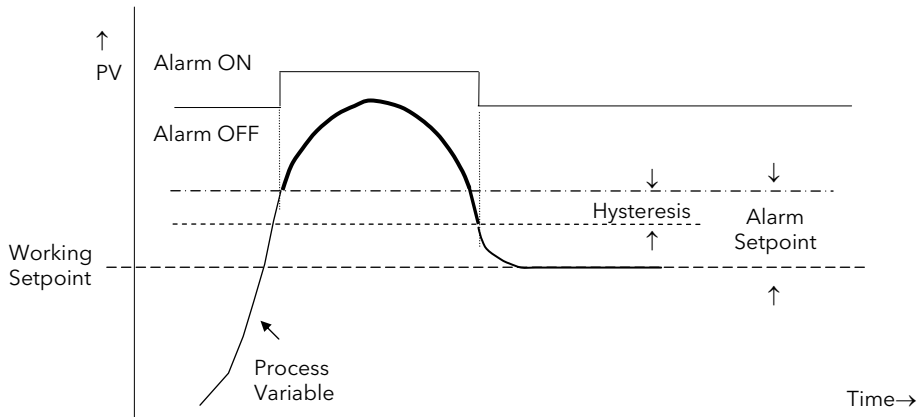
The Process Variable (PV) exceeds a set low level



9.2.3 Deviation High Alarm

The alarm occurs when the difference between the process variable and the setpoint is positive by greater than the alarm setpoint.

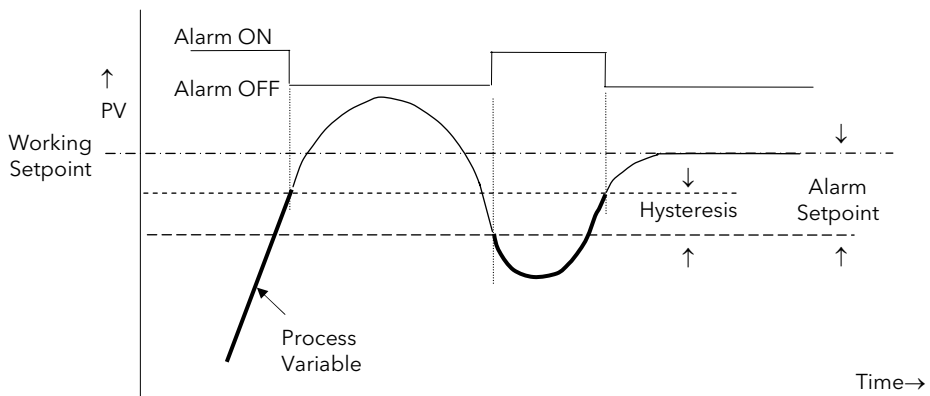
Note: For User Analogue Value the deviation is the difference between the two user wired analogue inputs.



9.2.4 Deviation Low Alarm

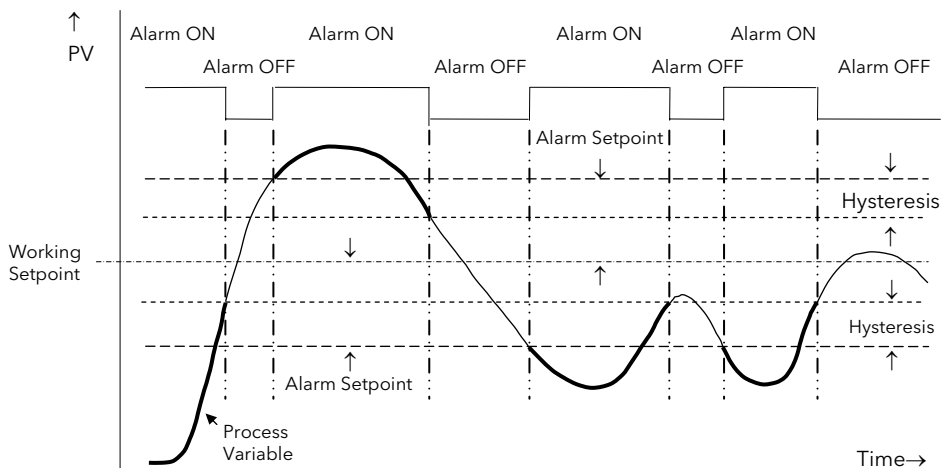
The alarm occurs when the difference between the process variable and the setpoint is negative by greater than the alarm setpoint.

Note: For User Analogue Value the deviation is the difference between the two user wired analogue inputs.



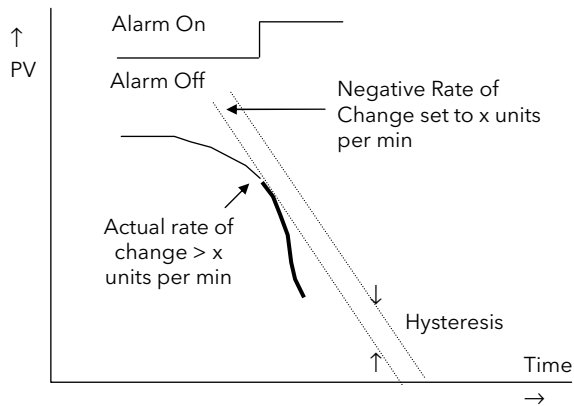
9.2.5 Deviation Band

A deviation band alarm monitors the process variable and the working setpoint and continuously compares the difference against the alarm setpoint. If the difference is either negative by less than, or positive by greater than the alarm setpoint, the alarm state will be active.



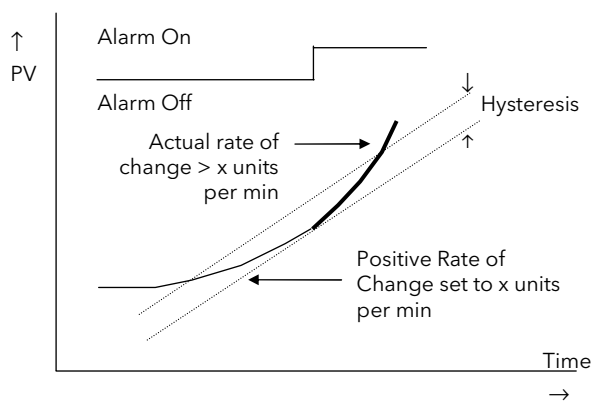
9.2.6 Rate Of Change Alarm - Negative Direction

The Process Value falls faster than the alarm setting.



9.2.7 Rate Of Change Alarm - Positive Direction

The Process Value rises faster than the alarm setting.



Notes:

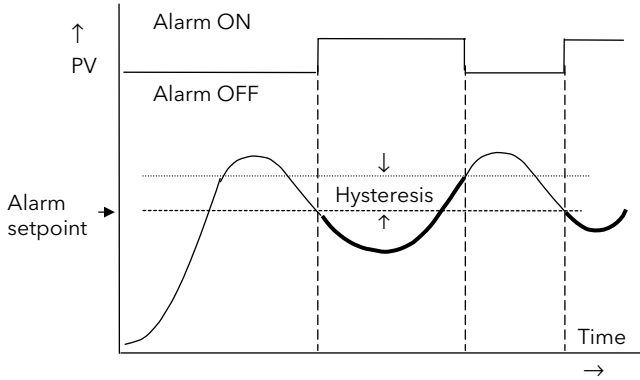
1. Separate alarms are required for positive and negative rates of change
2. An alarm is indicated during the period that the actual rate of change is greater than the set rate of change.
3. There may be a small delay before the instrument displays an alarm condition since the instrument requires several samples. This delay increases if the set value and actual value are close together
4. A hysteresis value of, say, 1 unit per second will prevent the alarm from 'chattering' if the rate of change varies by this amount

9.3 BLOCKING ALARMS

A Blocking Alarm only occurs **after** it has been through a start up phase. It is typically used to prevent alarms from being indicated until the process has settled to its normal working conditions.

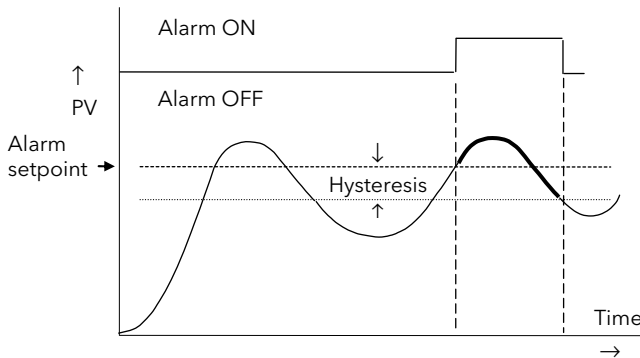
9.3.1 Full Scale Low With Blocking

The alarm only occurs **after** the start up phase when low alarm has first entered a safe state. The next time a low alarm occurs will cause the alarm to become active.



9.3.2 Full Scale High Alarm With Blocking

The alarm only occurs **after** the start up phase when high alarm has first entered a safe state. The next time a high alarm occurs will cause the alarm to become active.

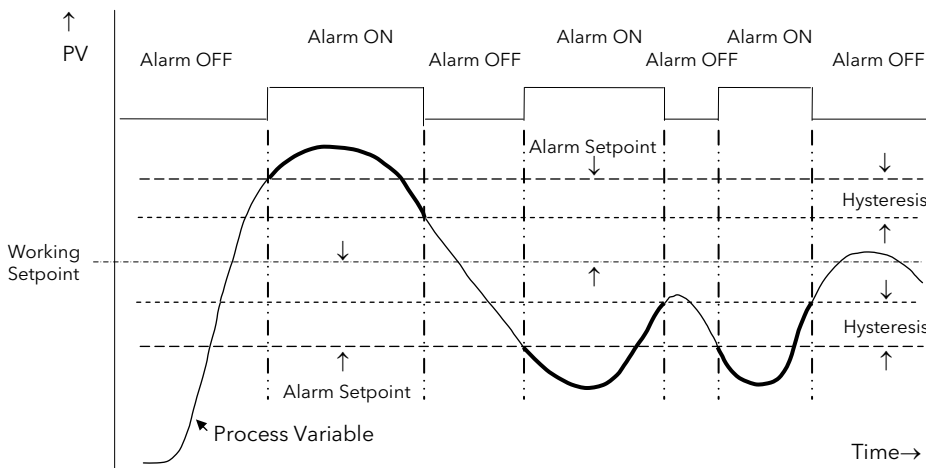


i.e. If the controller is powered up with $PV > \text{'Hi Alarm SP'}$ no alarm is indicated. The PV must reduce below the 'High Alarm SP' and increase again to $> \text{'Hi Alarm SP'}$. The alarm condition will then be indicated.

If the controller is powered up with $PV < \text{'Hi Alarm SP'}$ an alarm is indicated as soon as $PV > \text{'Hi Alarm SP'}$

9.3.3 Deviation Band With Blocking

The alarm only occurs **after** the start up phase when low deviation alarm has first entered a safe state. The next time an alarm occurs, whether high band or low band will cause the alarm to become active.



9.4 LATCHING ALARMS

The alarm is indicated until it is acknowledged by the user. Acknowledgement of an alarm can be through the controller front buttons, from an external source using a digital input to the controller or through digital communications.

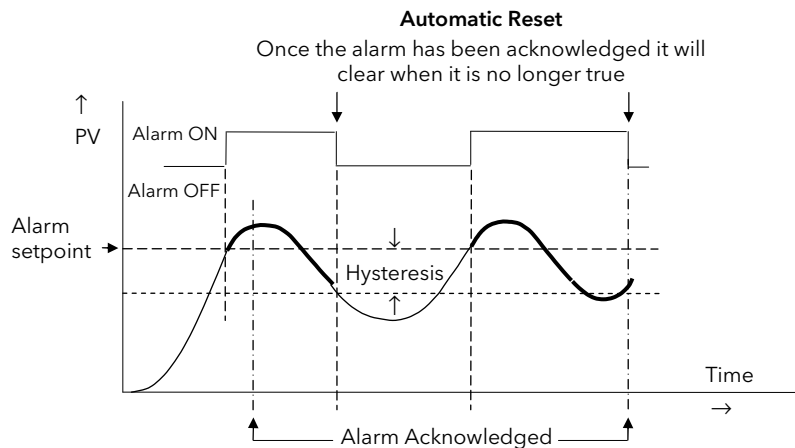
There are two ways that the alarm can be acknowledged:

1. **Automatic Reset.** The alarm continues to be active until both the alarm condition is removed AND the alarm is acknowledged. The acknowledgement can occur **BEFORE** the alarm condition is removed.
2. **Manual Reset.** The alarm continues to be active until both the alarm condition is removed AND the alarm is acknowledged. The acknowledgement can only occur **AFTER** the alarm condition is removed.

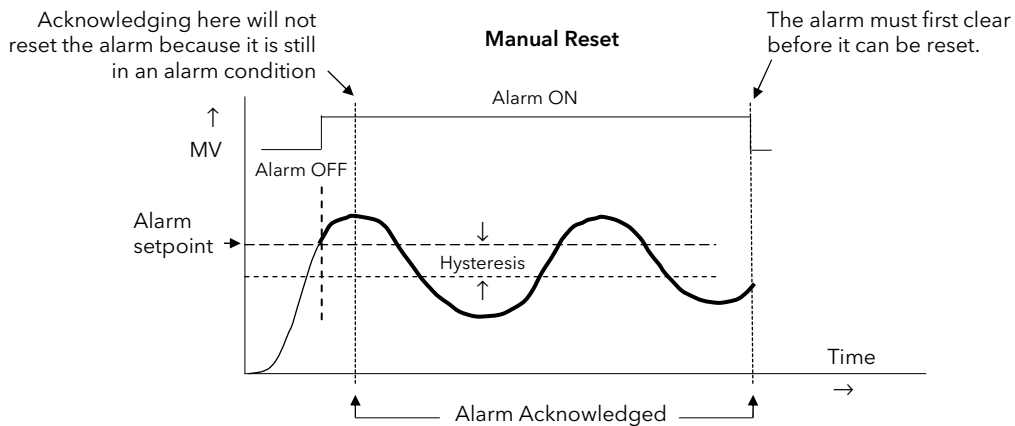
These are shown below for a Full Scale High Alarm

9.4.1 Latched Alarm (Full Scale High) With Automatic Reset

The alarm is displayed until it is acknowledged



9.4.2 Latched Alarm (Full Scale High) With Manual Reset



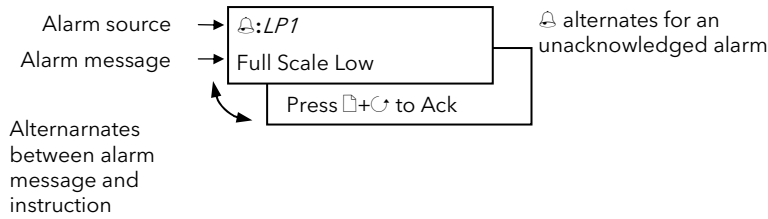
9.4.3 Grouped Alarms

Alarms can be associated with different aspects of the process. They are grouped in accordance with the functions they perform as follows:

Loop Alarms	Alarms associated with each control loop. Examples are: High, Low, Deviation and Rate of Change. Two alarms are available for each loop. On a new controller these are the only alarms which are configured - those listed below must be enabled in configuration level if they are required.
PV Input Alarms	Alarms which operate on the PV input. Examples are: High and Low. Two alarms are available with this input.
Analogue Input Alarms	Alarms which operate on the analogue input. Examples are: High and Low. Two alarms are available with this input.
Module Alarms	Alarms which operate on each plug in module. These can be input or output alarms depending upon the function of the module fitted. These alarms are associated with modules 1, 3, 4, 5, & 6, since module 2 is reserved as an extra memory module
User Alarms	Eight undedicated alarms which can be wired to any variable.

9.5 HOW ALARMS ARE INDICATED

Alarms are indicated when the controller is in normal operating level. When an alarm occurs a message will appear on the lower display which will indicate the source and the type of alarm. The format of this alarm message is:



In addition to the message the red ALM beacon will flash

When the alarm has been acknowledged the ALM beacon will illuminate permanently if the alarm condition is still present and the readout will revert to its previous display. If the alarm is no longer present when acknowledged the ALM beacon will extinguish and the message disappears.



If a relay has been connected to the output of the alarm, it will change state to allow an external beacon or audible device to be activated. By default the relay will de-energise when an alarm occurs and energise when the alarm is acknowledged, subject to the latching configuration.

9.5.1 Alarm Delay Time

A delay time can be set for each alarm between the occurrence of the alarm and the indication of the alarm in the controller. This is useful to prevent spurious alarms from being indicated in some noisy or rapidly changing processes.






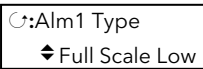



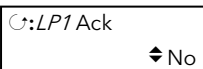



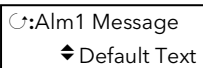



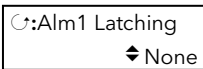







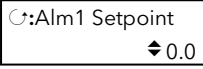



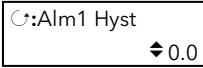



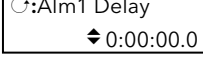



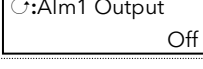

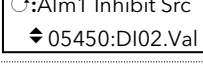


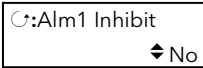



Delay time can only be set in Configuration level.

If delay time has been configured for the alarm the user may be aware that the occurrence of an alarm may not necessarily correspond with the display of the alarm

9.6 TO CONFIGURE LOOP 1 ALARM TYPE

There are two alarms associated with each loop. They are shown on the display as Alm1 and Alm2.

The procedure described below is the same for all alarms.

Do This	Instrument Display	Additional Notes
16. From any display press  as many times as necessary until the ' ALARMS ' page header is displayed		Text shown in <i>italics</i> is user definable and will appear if:- 1. User text is enabled in INSTRUMENT page, see section 5.2.5. 2. The text has been assigned to this parameter
17. Press  or  to select ' LP1 Page '		
18. Press  to select ' Alm1 Type '		The choices are:- Off Full Scale Low Full Scale High Deviation Band Deviation High Deviation Low Rate of Change
19. Press  or  to configure the alarm type		
20. Press  to select ' LP1 Ack '		The choices are:- N - No acknowledge Acknowledge - Alarm will need to be acknowledged in operation level. This parameter is also available in Level 1
21. Press  or  to select Acknowledge or No		
22. Press  to select ' Alm1 Message '		Default text - 'Full Scale Low', as set in 2 above, will be displayed in operation level when this alarm occurs. A choice of up to 50 messages may be substituted for the default message from the User Text 'library' configured in INSTRUMENT page, see section 5.2.5.
23. Press  or  to select a message which will appear on the display when the alarm occurs		
1. Press  to select Alm1 Latching		The choices are:- None Auto Manual Event
2. Press  or  to select the latching type		
3. Press  to select Alm1 Blocking		The choices are:- No Yes
4. Press  or  to select the latching type		
5. Press  to select Alm1 Setpoint		This parameter can also be changed in Level 1
6. Press  or  to set the alarm threshold value		
7. Press  to select Alm1 Hyst		This parameter can also be changed in Level 3
8. Press  or  to set the alarm hysteresis		
9. Press  to select Alm1 Delay		The alarm will not be displayed until the time set here has been exceeded.
10. Press  or  to set the alarm delay time		
11. Press  to select Alm1 Output		This indicates the state of the alarm. It is also shown in Level 1.
12. Press  to select Alm1 Inhibit Src		
13. Press  or  to select the source		No → the event is ignored Yes → the alarm waits for the event to become true.
14. Press  to select Alm1 Inhibit		
15. Press  or  to select No or Yes		

9.7 ALARM TABLES

The following alarm pages are available:-

Summary	A summary of all alarms. This table is also available in Level 3 but can be promoted to Level 1, see section 5.2.5.
Alarms Loop 1	See section 8.6 above
Alarms Loop 2	These are the same as loop 1
Alarms Loop 3	These are the same as loop 1
PV Input	High and Low Alarms are available for the fixed PV Input.
Analogue Input	High and Low Alarms are available for the fixed Analogue Input.
Module 1, 3, 4, 5 & 6	High and Low Alarms are available each module.
User 1 to 8	These are alarms which are user defined

Alarms for these pages are configured as in section 8.6

9.7.1 ALARMS (Summary Page)

Table Number: 8.7.1. These parameters indicate alarm status		ALARMS (Summary Page)			
Alarm parameters in this table only appear if the alarm is enabled. The last three parameters in the table always appear.					
Parameter Name	Parameter Description	Value		Default	Access Level
<i>LP1 Ack1</i>	Loop 1 alarm 1 acknowledge	No	Yes		L1
<i>LP1 Ack2</i>	Loop 1 alarm 2 acknowledge	No	Yes		L1
<i>LP2 Ack1</i>	Loop 2 alarm 1 acknowledge	No	Yes		L1
<i>LP2 Ack2</i>	Loop 2 alarm 2 acknowledge	No	Yes		L1
<i>LP3 Ack1</i>	Loop 3 alarm 1 acknowledge	No	Yes		L1
<i>LP3 Ack2</i>	Loop 3 alarm 2 acknowledge	No	Yes		L1
<i>PV Alm AckH</i>	PV Input high alarm acknowledge	No	Yes		L1
<i>PV Alm AckL</i>	PV Input low alarm acknowledge	No	Yes		L1
<i>An Alm AckH</i>	Analogue Input high alarm acknowledge	No	Yes		L1
<i>An Alm AckL</i>	Analogue Input low alarm acknowledge	No	Yes		L1
<i>Module 1A 1 AckH</i>	Module 1 high alarm acknowledge	No	Yes		L1
<i>Module 1A 1 AckL</i>	Module 1 low alarm acknowledge	No	Yes		L1
The above two alarms are repeated for Module 3, 4, 5 and 6 if the modules are fitted					
User 1 Ack	User defined alarm 1 acknowledge	No	Yes		L1
The above alarm is repeated for up to eight user alarms if they have been configured					
New Alarm	Set to true on a new alarm	No	Yes		R/O
Ack All Alms?	Acknowledges all alarms (Global acknowledge)	No	Yes		L3
Ack All Src	Global Acknowledge Source	Modbus Address			Conf

9.7.2 ALARMS LP1 (2 or 3) Page Parameters

Table Number: 8.6.2.		These parameters configure the Loop 1 alarms. Alarm 1 parameters only appear if 'Alm 1 Type' ≠ 'None' Alarm 2 parameters only appear if 'Alm 2 Type' ≠ 'None'		ALARMS (LP1) Page	
Parameter Name	Parameter Description	Value	Default	Access Level	
Alm1 Type	Alarm 1 Type	Off Full Scale Low Full Scale High Deviation Band Deviation High Deviation Low Rate of Change	As order code	Conf	
LP1 Ack	Group alarm acknowledge for loop 1. Acknowledges both loop alarms.	No Acknowledge	No	L1	
Alm1 Message	Alarm 1 message. Use △ or ▽ to choose from User Text library set up in section 5.2.6.	Default Text or User defined Text 01 to 50	Default Text	Conf	
Alm1 Latching	Alarm 1 latching. Use △ or ▽ to choose latching type	None Auto Manual Event	None	Conf	
Alm1 Blocking	Alarm 1 blocking. Use △ or ▽ to enable/disable	No Yes	No	Conf	
Alm1 Setpoint	Alarm 1 Setpoint	Controller range	0.0	L1	
Alm1 Hyst	Alarm 1 hysteresis	Controller range		L3	
Alm1 Delay	Alarm 1 delay	0:00:00.0	0.0	Conf	
Alm1 Output	Alarm 1 output	Off On	Off	R/O	
Alm1 Inhibit Src	Alarm 1 inhibit source	Modbus address	None	Conf	
Alm1 Inhibit	Alarm 1 inhibit	No Yes	No	L3	

Alm2 parameters are the same as Alm1 when 'Alm2 Type' ≠ 'None'

9.7.3 ALARMS (PV Input Page) Parameters

Table Number: 8.7.3.		These parameters set up the alarms associated with the PV input signal. They are only displayed if enabled using the parameter FS Hi Alarm or FS Lo Alarm		ALARMS (PV Input)	
Parameter Name	Parameter Description	Value	Default	Access Level	
FS Hi Alarm	Full scale high alarm enable/disable	Disabled Enabled	Disabled	Conf	
<i>PV Alm Ack</i>	Group acknowledge. Acknowledges both Hi and Lo alarms	No Acknowledge		L1	
FS Hi Message	Full scale high message. Use \triangle or ∇ to choose from the User Text messages set up in section 5.2.6.	Default Text or User defined Text 01 to 50	Default Text	Conf	
FS Hi Blocking	Full scale high blocking. Use \triangle or ∇ to enable/disable	No Yes		Conf	
FS Hi Latching	Full scale high latching. Use \triangle or ∇ to choose latching type	None Auto Manual Event		Conf	
FS Hi Setpoint	Full Scale High Alarm (1) Setpoint	Controller range		L1	
FS Hi Hyst	Full Scale High alarm (1) hysteresis	Controller range		L3	
FS Hi Delay	Full Scale High alarm (1) delay	0:00:00.0		Conf	
FS Hi Output	Full Scale High alarm (1) output	Off On	Off	R/O	
FS Lo Alarm	Full scale Low alarm enable/disable	Disabled Enabled	Disabled	Conf	
FS Lo parameters are the same as FS Hi parameters if 'FS Lo Alarm' = 'Enabled'					
Inhibit Src	Alarm inhibit source	Modbus Address		Conf	
Inhibit	Alarm inhibit value	No Yes	No	L3	

9.7.4 ALARMS (An Input Page) Parameters

The parameters for the Analogue Input Alarms are identical to the PV Input Alarms

9.7.5 ALARMS (Module 1,3, 4, 5 & 6 Page) Parameters

The parameters for the Module Alarms are identical to the PV Input Alarms. Module alarm pages only appear if suitable modules are fitted.

9.7.6 ALARMS (User 1 to 8 Page) Parameters

Table Number: 8.7.6. These parameters set up user defined alarms.		ALARMS (User 1 (to 8) Page)		
Parameter Name	Parameter Description	Value	Default	Access Level
Type	Alarm Type	Off Full Scale Low Full Scale High Deviation Band Deviation High Deviation Low Rate of Change	As order code	Conf
User 1 Ack	Group alarm acknowledge for user alarm 1	No Acknowledge	No	L1
Src A	Alarm source A	Modbus address	None	Conf
Src B	Alarm source B	Modbus address	None	Conf
Name	User defined alarm name. Use \triangle or ∇ to choose from User Text library set up in section 5.2.6.	Default Text or User defined Text 01 to 50	Default Text	Conf
Message	User defined message. Use \triangle or ∇ to choose from User Text library set up in section 5.2.5.	Default Text or User defined Text 01 to 50	Default Text	Conf
Latching	Indicates if the alarm has been configured as latching	None Auto Manual Event		R/O at L3
Blocking	Indicates if the alarm has been configured as blocking	No Yes		R/O at L3
Setpoint	Alarm Setpoint	Controller range		L1
Hyst	Alarm hysteresis	Controller range		L3
Delay	Alarm delay	0:00:00.0		Conf
Output	Alarm output	Off On	Off	R/O at L1
Val A	Used if the user alarm is deviation. Normally internally wired to the PV	Disp min to disp max		R/O at L3 if wired to PV source
Val B	Used if the user alarm is deviation. Normally internally wired to the SP	Disp min to disp max		R/O at L3 if wired to PV source
Inhibit Src	Alarm inhibit source	Modbus address		Conf
Inhibit	Alarm inhibit	No Yes	No	L3

The above table is repeated for:

User alarm 2 User alarm 5
 User alarm 3 User alarm 6
 User alarm 4 User alarm 7
 User alarm 8

9.8 ALARM WIRING EXAMPLES

9.8.1 Control Loop With High and Low Alarms

In this example two alarms are added to the loop wiring example shown in Section 3.1. Alarm 1 is configured as a high alarm and operates the fixed relay 'AA'. This relay is inhibited until a digital input, 'DIO1' becomes true. Alarm 2 is configured as a low alarm and operates a relay module in slot 3.

----- = Connections made in example shown in Section 3.1

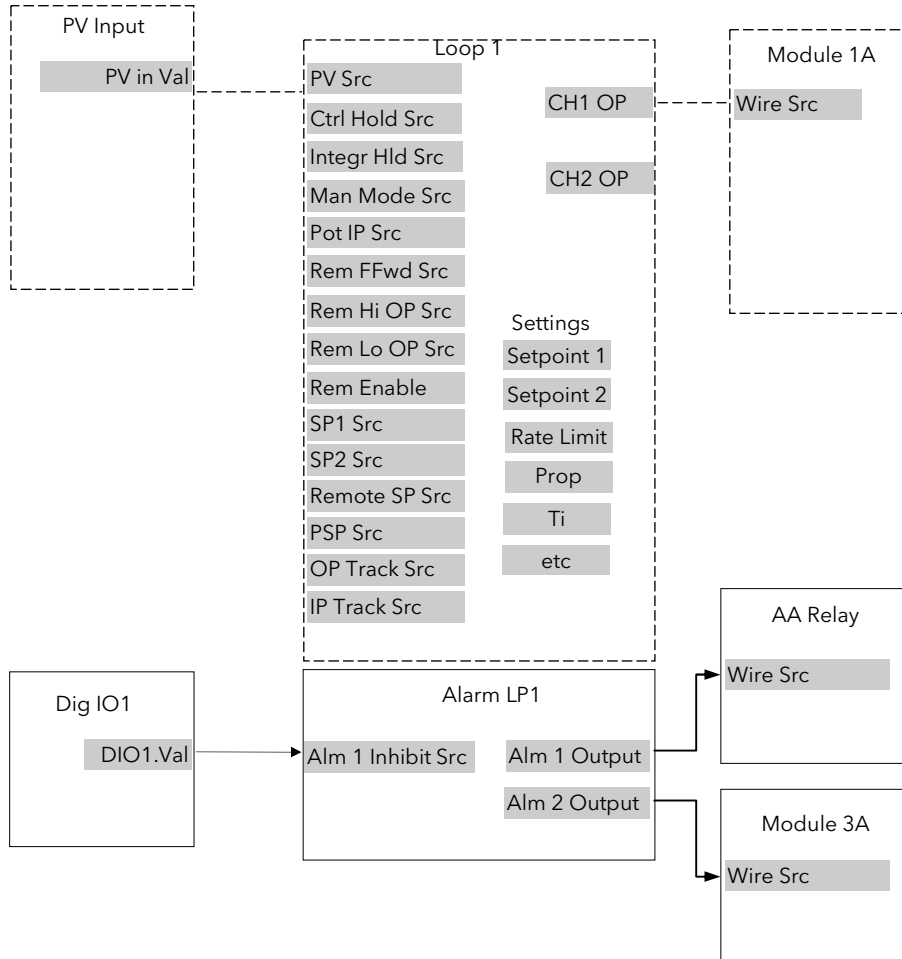


Figure 9-1: Loop Alarm Wiring

9.8.1.1 Implementation

- | | |
|---------------------------------|--|
| 1. In ALARMS/LP1 Page | set 'Alm1 Type' = Full Scale High |
| 2. In ALARMS/LP1 Page | set 'Alm2 Type' = Full Scale Low
(Note: other parameters such as alarm message, alarm latching, alarm blocking are also set in this page) |
| 3. In ALARMS/LP1 Page | Set 'Alm1 Inhibit Src' = 05402:DO1.Val
This connects the alarm 1 inhibit to fixed digital input 1 |
| 4. In STANDARD IO/AA Relay Page | Set 'Wire Src' = 11592:L1Alm1.OP
This connects Alarm 1 output to operate the AA relay |
| 5. In MODULE IO/Module 3A Page | Set 'Wire Src' = 11602:L1Alm2.OP
This connects Alarm 2 output to operate the relay fitted in module position 3. |

See Appendix D for list of Modbus addresses.

© Tip:- See 'Copy and Paste' description in Chapter 3.

9.8.2 Loop Alarm Inhibited if Programmer not in Run

In this example the alarm is gated as in the previous example. To determine if the programmer is in Run mode an Analogue Operator (An Oper 1) is used.

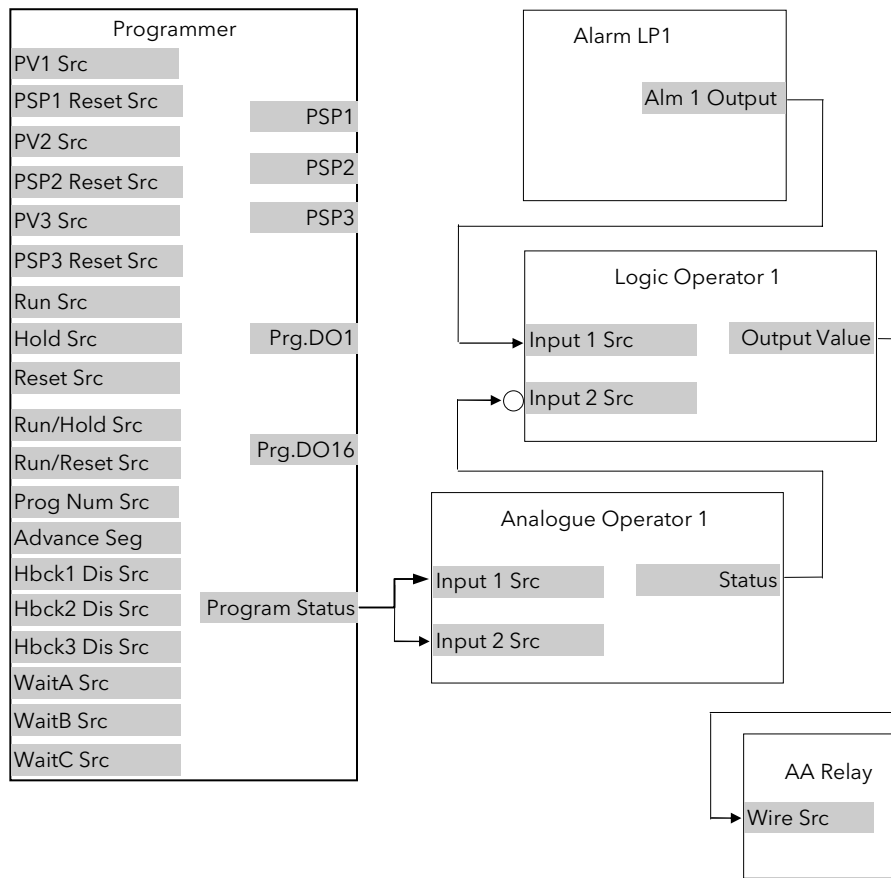


Figure 9-2: Loop Alarm Inhibited if Programmer not in Run

9.8.2.1 Implementation

1. In LOGIC
OPERS/Logic 1 Page
 - set 'Operation' = AND
 - set 'Invert' = Invert Input 1
 - Invert input 1 is necessary because the previous operation results in 0 for a true state
 - Set 'Input 1 Src' = 06239:-----
 - This is the Status of the Logic Operator
 - Set 'Input 2 Src' = 11592: L1Alm1.OP
 - This sets the logic operator such that both inputs must be true before the output status is true

2. In ANALOGUE
OPERS/Analogue 1
 - set 'Operation' = Select Max
 - set 'Input 1 Src' = 05844:-----
 - This is the Programmer Status
 - set 'Input 2 Src' = 05844
 - It is necessary to connect both inputs of an analogue operator
 - set 'Input 1 Scalar' = 1
 - set 'Input 1 Scalar' = 2
 - set 'Low Limit' = +1
 - set 'High Limit' = +1
 - (Note: when Programmer Status = Run the result of the calculation is 0)

3. In STANDARD IO/AA
Relay Page
 - Set 'Wire Src' = 07176:LgOp1.OP
 - This connects Logic Operator 1 output to operate the AA relay

10.CHAPTER 10 LOOP SET UP

In the controller LOOP SET UP appears after AUTOTUNE in the operator display. In this manual, however, an explanation of how to set up each loop is given before the tuning procedure. Also the order in which each sub-header appears in this chapter is not necessarily the same as the order in which they appear in the controller because single loop control is explained before dual loops.

10.1 WHAT IS LOOP SET UP

The 2604 controller can have up to three control loops. Each loop operates independently and can be configured for On/Off, PID or Valve Positioning control. Additionally, each loop can have an auxiliary loop associated with it, and this allows other control strategies to be implemented such as cascade, ratio and override control. The LOOP SETUP pages allow you to configure the type of control most suited to your process. The pages are divided into a number of sub-headers - briefly described below:-

LP1 (2 or 3) SETUP ▶	SP Page	Allows you to configure the setpoint parameters for a particular loop
Note: Text shown in <i>italics</i> is user definable in configuration mode and may be different from that shown	(SP(Aux))Page	Allows you to configure the setpoint parameters for an auxiliary loop
	Cascade Page	These parameters only appear if the control loop is configured for cascade control.
	Ratio Page	These parameters only appear if the control loop is configured for ratio control.
	Override Page	These parameters only appear if the control loop is configured for override control.
	PID Page	These parameters allow you to set up the three term or PID values for the selected loop. See also Chapter 11 'Controller Applications'
	PID (Aux) Page	These parameters allow you to set up the three term or PID values for the selected auxiliary loop. See also Chapter 10 'Tuning'
	Motor Page	Allows you to set up the values for a valve positioning output when the selected loop is configured for motorised valve control. See also Chapter 11 'Controller Applications'
	Output Page	Allows you to set up the values for the output when the selected loop is configured for analogue or digital control outputs.
	Diagnostic Page	These parameters are for diagnostic purposes on the selected loop.
(Diag Aux) Page	These parameters are for diagnostic purposes on the selected auxiliary loop.	

10.1.1 LOOP SET UP (Options page)

Table Number: 9.1.1. This page determines the control action ^(x) See notes for further parameter descriptions		LP1 SETUP Options Page		
Parameter Name	Parameter Description	Value	Default	Access Level
Loop Type	To configure loop type	Single Cascade Override Ratio	As order code	Conf
Control Type ⁽¹⁾	Control type	See note 1	As order code	Conf
Control Action ⁽²⁾	Control action	Reverse Direct	Reverse	Conf
Aux Ctl Action ⁽²⁾	Control action of the auxiliary loop	Reverse Direct	Reverse	Conf
Cool Type ⁽³⁾	Cooling action	Linear Oil Water Fan Proportional		Conf
Prog Setpoint ⁽⁴⁾	Loop 1 PSP select	PSP1 PSP2 PSP3 None		Conf

Deriv Type ⁽⁵⁾	Derivative type	PV Error	PV	Conf
FF Type ⁽⁶⁾	Feedforward type	None Remote FeedFwd SP Feedforward PV Feedforward		Conf
Force Man Mode ⁽⁷⁾	Forced manual output mode.	Off Track Step		Conf
Rate Lim Units ⁽⁸⁾	Rate limit units	Per Second Per Minute Per Hour	Per minute	Conf
Bumpless PD	Initialises the manual reset on Auto/Manual transfer	Yes No	Yes	Conf
Ti/Td Units	Integral and Derivative time units	sec min	sec	Conf
OnOff SBk Type	Sensor break action. Only appears if On Off control is configured	-100 0 100		Conf
Prop Bnd Units	Proportional band units	Eng Units and %		Conf
Enable Pwr Fbk	Power feedback enable	Off On		Conf
Rem SP Config	Remote setpoint configuration	SP Only LSP Trim RSP Trim	SP Only	Conf
SBrk Type	Sensor break type	Output Hold		Conf
Manual Track ⁽⁹⁾	Manual track	Off Track		Conf
Remote Track ⁽¹⁰⁾	Remote tracking	Off Track		Conf
Program Track ⁽¹¹⁾	Programmer track	Off Track		Conf
Start SRL Mode ⁽¹²⁾	Defines Setpoint Rate Limit action on power up.	None Hold Clear Hold	None	Conf
Start Rem Mode ⁽¹³⁾	Defines Local/Remote action on power up.	No Change Local Remote	No Change	Conf
Startup Mode ⁽¹⁴⁾	Manual mode on power up	Continue SBrk Output	Continu e	Conf
Start WSP Mode ⁽¹⁵⁾	Defines the Working SP action on power up.	None PV Target SP		Conf
Ramp from working SP		Yes No		

Notes

1. Control Types

PID-Ch1 Only	Channel 1 PID only. Use for single channel control only
OnOff-Ch1 Only	Channel 1 On/Off. Use for On/Off control.
VP-Ch1 Only	Channel 1 Motorised valve position output - boundless mode.
VPB-Ch1 Only	Channel 1 Motorised valve position output - bounded mode.
PID-Ch1 PID-Ch2	Both output channels PID. Use for heat/cool type applications
PID-Ch1 OnOff-Ch2	Channel 1 PID control, channel 2 On/Off. Use for single channel PID control plus On/Off Control
OnOff-Ch1&2	Both output channels On/Off. Use for On/Off control

2. Control Action

Direct The output will increase positively if the $PV > SP$.

Reverse The output will increase positively if $PV < SP$.

3. Cool Type

Linear The control output follows linearly the PID output signal, i.e. 0% PID demand = 0 power output, 50% PID demand = 50% power output, 100% PID demand = 100% power output.

Oil, Water, Fan The control output is characterised to compensate for the non-linear effect of the cooling medium - oil, water and blown air. Typically used in extrusion processes.

Proportional The control output is proportional to the error

4. Prog Setpoint

When the programmer is running, this parameter determines from which setpoint profile the loop obtains its setpoint. If None is selected this parameter can be soft wired.

5. Deriv Type

Derivative on PV defines that derivative action responds to changes to PV only

Derivative on Error defines that derivative action responds to changes to differences between SP and PV.

6. FF Type

Feedforward control is used typically to overcome time delays or to compensate for the effect of external influences such as control signals from other loops in the process. This is added directly to the output of the PID algorithm, before output limiting and dual output conversions are performed. Trim Limit applied to the PID calculated output is possible when Feedforward is enabled.

7. Force Manual Mode

Force Manual Mode allows you to select how the loop behaves on auto/ manual transfer.

Off	Transfer between auto/manual/auto takes place bumplessly
Track	Transfer from auto to manual, the output reverts to the <u>previous</u> manual value. Transfer from manual to auto takes place bumplessly
Step	Transfer from auto to manual, the output goes to a pre-set value. This value is set by the parameter 'Forced OP' in <i>LPx</i> SETUP/Output Page, section 9.6. Transfer from manual to auto takes place bumplessly

8. Rate Limit Units

Rate limit can be applied to the SP, such that the change in PV takes place at a controlled rate. It is used where a full programmer is not justified and is typically used to protect the process from sudden changes in the PV.

9. Manual Track

When the controller is switched into Manual mode the working setpoint tracks the value of the PV so that on return to Auto mode is bumpless.

10. Remote Track

When the controller is switched into Remote SP mode the local setpoint tracks the value of the remote SP so that the return to Local SP is bumpless.

11. Program Track

When the controller is running a program the local setpoint tracks the value of the program setpoint. If the controller is switched to Local SP the transfer takes place bumplessly.

12. Start SRL Mode

Defines Setpoint Rate Limit action on power up.

None = No Change. Setpoint Rate Limit starts up in the same mode as power off

Hold = Setpoint Rate Limit is in hold mode on power up

Clear Hold = Setpoint Rate Limit is active on power up

13. Start Rem Mode

Defines Local/Remote action on power up.

No Change = The controller powers up in the same mode as power off

Local = The controller starts up in Local setpoint mode

Remote = The controller starts up in Remote setpoint mode

14. Manual Mode on Power up

This parameter provides the choice between 'Continue' and 'SBrk Output' as the start up control mode.

Selecting Continue ensures that on power up the loop control action will remain at its last state. Selecting 'SBrk Output' forces the relevant loop into the manual mode with 'SBrk OP' (Loopx → SETUP → Output) applied to the output.

15. Start WSP Mode

Defines the Working SP action on power up.

None = No Change. The controller powers up in the same mode as power off

PV = The controller servos to PV on power up

Target SP = The controller servos to the target setpoint on power up

10.2 SINGLE LOOP CONTROL

Single loop control is configured when 'Loop Type' (Options Page) = 'Single'. A block diagram of a simple single loop, single output controller is shown below:

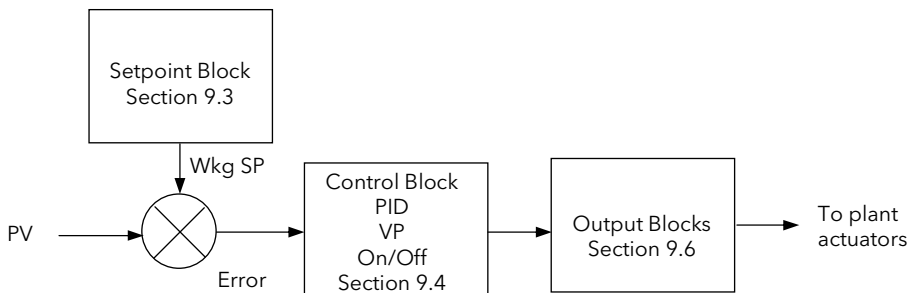


Figure 10-1: Single Loop Controller

10.2.1 LOOP SET UP (Wiring page) SINGLE LOOP

Table Number: 9.2.1.		These parameters allow you to soft wire between function blocks.		LP1 SETUP Wiring Page	
Parameter Name	Parameter Description	Value	Default	Access Level	
PV Src	Process variable source	Modbus address	05108: PVIn.Val	Conf	
Manual OP Sr	Target OP power source	Modbus address		Conf	
OPRtLim En S	OP rate limit enable source	Modbus address		Conf	
OPRtLim Src	OP rate limit source	Modbus address		Conf	
Ctrl Hold Src	Freeze control flag source	Modbus address		Conf	
Integr Hld Src	Integral hold flag source	Modbus address		Conf	
Man Mode Src	Auto/manual select source	Modbus address		Conf	
Pot IP Src	Pot position source	Modbus address		Conf	
Rem FFwd Src	Remote feedforward source	Modbus address		Conf	
Rem Hi OP Src	Remote high power limit source	Modbus address		Conf	
Rem Lo OP Src	Remote low power limit src	Modbus address		Conf	
The above two parameters do not appear if Control Type (Table 9.1.1.) = On/Off					
Rem SP Ena Src	Remote setpoint enable source	Modbus address		Conf	
Remote SP Src	Remote setpoint source	Modbus address		Conf	
SP Select Src	Internal setpoint select src	Modbus address		Conf	
SP1 Src	Setpoint 1 source	Modbus address		Conf	
SP2 Src	Setpoint 2 source	Modbus address		Conf	
Rt Lim Dis Src	SP rate limit disable src	Modbus address		Conf	
Rt Lim Src	SP rate limit src	Modbus address		Conf	
Rt Lim Hld Src	SP rate limit hold source	Modbus address		Conf	
Prog SP Src	LP1 PSP wire source	Modbus address		Conf	
PID Set Src	PID Set Source	Modbus address		Conf	
RemSchedIP	Remote scheduling input source	Modbus address		Conf	
Power FF Src	Power feedforward source	Modbus address		Conf	
Track Enab Src ⁽¹⁾	OP track enable source	Modbus address		Conf	
Track Src	Track output source	Modbus address		Conf	
Ext FBack Src	External feedback source	Modbus address		Conf	
Prop Band S	Proportional band source	Modbus address		Conf	
Integral Src	Integral term source	Modbus address		Conf	
Derivative Src	Derivative term source	Modbus address		Conf	
Aux Prop Sr	Auxiliary loop proportional band source	Modbus address		Conf	
Aux Integral	Auxiliary loop integral term source	Modbus address		Conf	
Aux Derivative	Auxiliary loop derivative term source	Modbus address		Conf	

10.3 SETPOINT DEFINITION

The controller setpoint is the **Working Setpoint (WSP)** which may be sourced from a number of alternatives. This is the value ultimately used to control the process variable in a loop.

LSP derives from a parameter called the local setpoint which is the value the operator can alter. This local SP may be derived from one of two setpoints, **Setpoint 1 (SP1)** or **Setpoint 2 (SP2)**. Either of these setpoints may be selected by a parameter in the controller or soft wired to a digital input.

In remote mode, the working setpoint is modified by the **Remote SP + Local Trim**, when 'Enable Rem SP' is set to 'Yes'. When 'Remote Track' (*LP1 SETUP/Options Page*) is set to 'Track' the transition to the 'Active Local SP' (SP1 or SP2) takes place bumplessly and the Active Local SP tracks the value of the Remote SP.

In a controller/programmer the Working SP is derived from the output of the programmer function block. In this case the setpoint varies in accordance with fixed rates of change stored within a program.

10.3.1 Setpoint Function Block

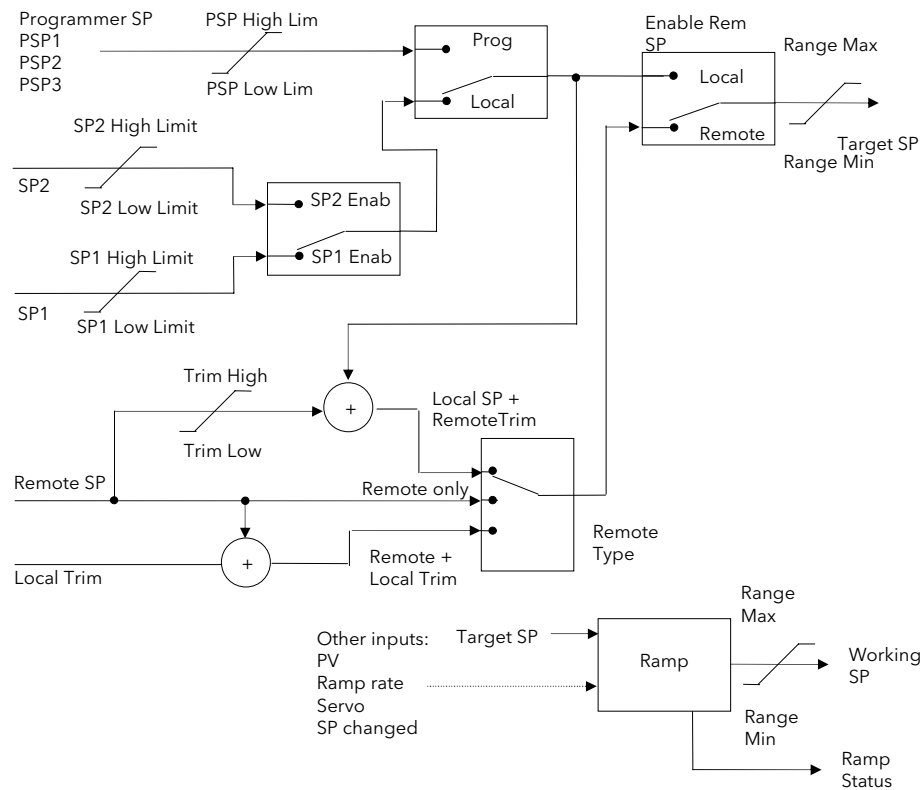


Figure 10-2: Setpoint Function Block

10.3.2 Setpoint Parameters

Table Number: 9.3.2. This list allows you to configure SP parameters. Other parameters are available in operation levels.		LP1 SETUP (SP Page)		
Parameter Name	Parameter Description	Value	Default	Access Level
Range Min	PV low limit	Min to max disp. limit	-200 *	Conf
Range Max	PV high limit		1372 *	Conf
SP Select	Internal setpoint select	Setpoint 1 Setpoint 2		L1
SP1 Low Limit	Setpoint 1 low limit	Range units	-200 *	L3
SP1 High Limit	Setpoint 1 high limit		1372 *	L3
Setpoint 1	Setpoint 1 value			L1
SP2 Low Limit	Setpoint 2 low limit		-200 *	L3
SP2 High Limit	Setpoint 2 high limit		1372 *	L3
Setpoint 2	Setpoint 2 value			L1
Disable Rt Lim	Setpoint Rate limit disable	No Yes		L3
Rt Lim Hold	SP rate limit hold	No Yes	No	L3
Rate Limit Val	Rate of change of setpoint	Off to range		L3
Trim Lo Lim	Local setpoint trim low limit	Range units		L3
Trim Hi Lim	Local setpoint trim high limit	Range		L3
Local SP Trim	Applies a trim value to the remote setpoint	units		L1
Enable Rem SP	Remote setpoint enable	No Yes		L1
Remote SP	Remote setpoint value	Range units		L1
HBk Type	SP rate limit holdback type	Off Low High Band		L3
HBk Value	SP rate limit holdback value	Display range		R/O
HBk Status	SP rate limit holdback status	Off Holdback		L3

* If temp units = °C

10.3.3 LP1 SETUP (SP Aux) Page

Table Number: 9.3.3 This list allows you to configure auxiliary loop setpoint limits. It only appears if cascade or override control is configured, see sections 9.10. and 9.12. Other parameters are available in operation levels.		LP1 SETUP (SP Aux) Page		
Parameter Name	Parameter Description	Value	Default	Access Level
Range Min	Auxiliary PV low limit	Min to max display limit	-200 *	Conf
Range Max	Auxiliary PV high limit		1372 *	Conf
SP Low Limit	Auxiliary setpoint 1 low limit	Range units	-200 *	L3
SP High Limit	Auxiliary setpoint 1 high limit		1372 *	L3
OVR SP Trim	Override loop setpoint trim			L3. Only appears when Override control is configured
Local SP	The setpoint which the controller reverts to when not in cascade, ratio or override			L1
Working SP	The current value of the setpoint in use			L1

* If temp units = °C

This table does not appear if the Loop Type is Ratio or Single.

10.4 PID CONTROL

PID control, also referred to as 'Three Term Control', is a technique used to achieve stable straight line control at the required setpoint. The three terms are:

P Proportional band

I Integral time

D Derivative time

The output from the controller is the sum of the contributions from these three terms. The combined output is a function of the magnitude and duration of the error signal, and the rate of change of the process value. It is possible to set P, PI, PD or PID control.

10.4.1 Proportional Term

The proportional term delivers an output which is proportional to the size of the error signal. An example of this is shown in Figure 9.3, for a temperature control loop, where the proportional band is 10°C and an error of 3°C will produce an output of 30%.

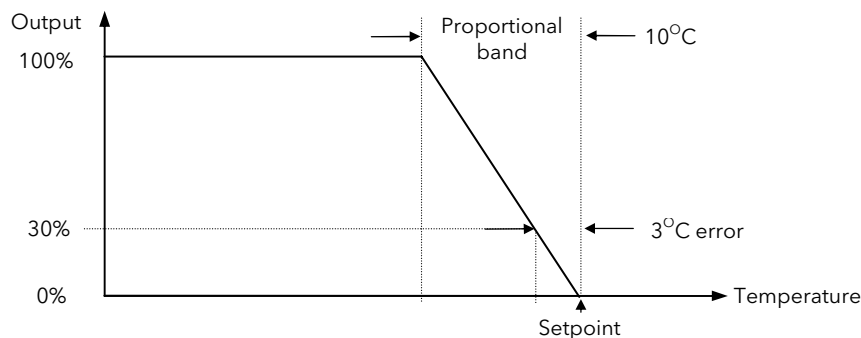


Figure 10-3: Proportional Action

Proportional only controllers will, in general, provide stable straight line control, but with an offset corresponding to the point at which the output power equals the heat loss from the system.

10.4.2 Integral Term

The integral term removes steady state control offset by ramping the output up or down in proportion to the amplitude and duration of the error signal. The ramp rate (reset rate) is the integral time constant, and must be longer than the time constant of the process to avoid oscillations.

10.4.3 Derivative Term

The derivative term is proportional to the rate of change of the temperature or process value. It is used to prevent overshoot and undershoot of the setpoint by introducing an anticipatory action. The derivative term has another beneficial effect. If the process value falls rapidly, due, for example, an oven door being opened during operation, and a wide proportional band is set the response of a PI controller can be quite slow. The derivative term modifies the proportional band according to this rate of change having the effect of narrowing the proportional band. Derivative action, therefore, improves the recovery time of a process automatically when the process value changes rapidly.

Derivative can be calculated on change of PV or change of Error. For applications such as furnace control, it is common practice to select Derivative on PV to prevent thermal shock caused by a sudden change of output following a change in setpoint.

10.4.4 High and Low Cutback

While the PID parameters are optimised for steady state control at or near the setpoint, high and low cutback parameters are used to reduce overshoot and undershoot for large step changes in the process. They respectively set the number of degrees above and below setpoint at which the controller will start to increase or cutback the output power.

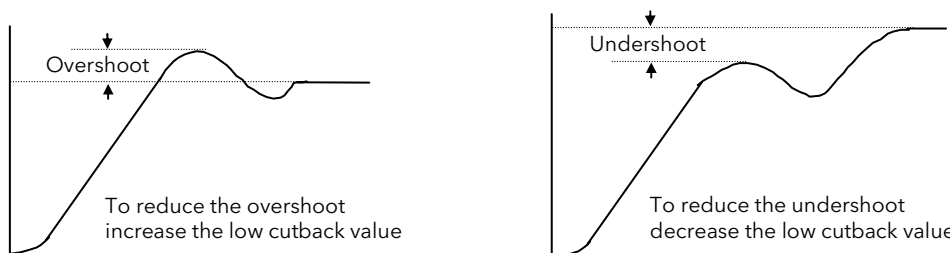


Figure 10-4: High and Low Cutback

10.4.1 PID Block Diagram

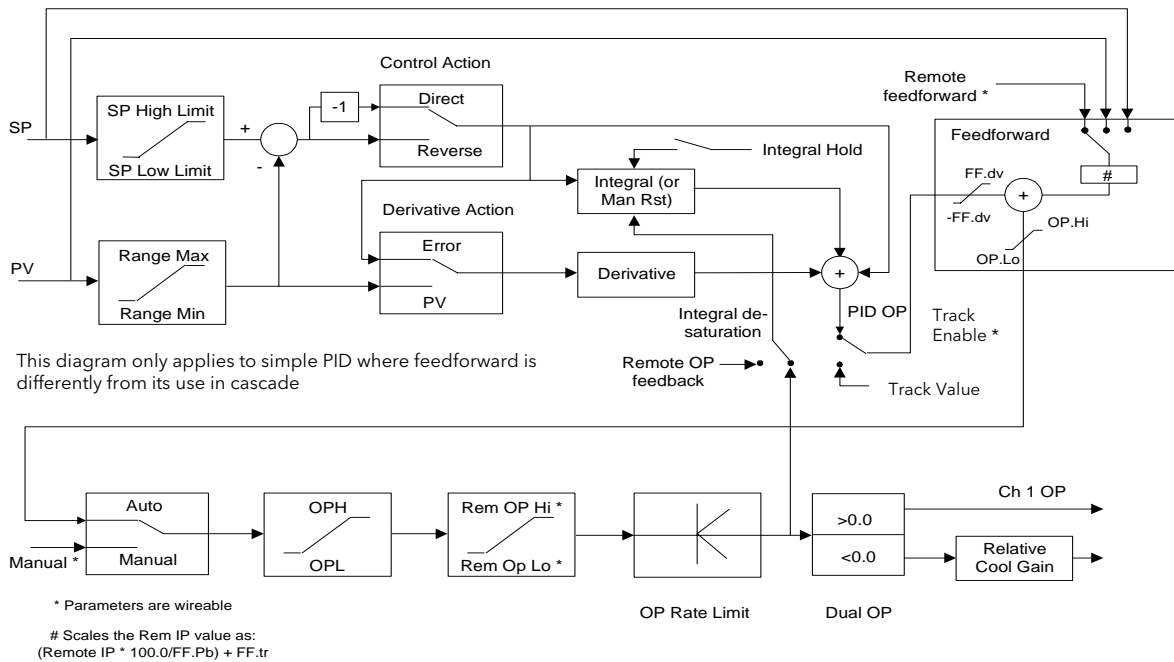


Figure 9-4a: Block Diagram

10.4.1 Remote (External) OP Feedback

The Remote OP Feedback shown in the PID block diagram, allows an external source of output to stop integral wind up in some applications such as cascade control. The integral will calculate a PID output to match the external value when manual to auto bumpless transfer is activated.

If 'Ena OP Track' (LP1 SETUP/Output) = 'Yes', the output will be replaced by the 'OP Track Value'. The feedback signal is used for the integral de-saturation. When the 'Remote OP Feedback' is wired the feedback signal is forced to a remote output feedback. When not wired the default internal OP is used for the integral calculation.

10.4.2 Analogue Value

The Analogue Value is a customisable parameter available in the PID (and PID Aux) pages which provides the user with additional flexibility when designing a control strategy. This parameter is called **Analogue Value (An Value 1 to 3)**. It is available for each PID set if Gain Scheduling has been configured and for each loop configured. It can be 'soft wired' in configuration mode to perform a specific function relevant to the particular process being controlled. Examples include: Output Power Limit, SP Feedforward Trim, etc.,

10.5 GAIN SCHEDULING

Gain scheduling is the automatic transfer of control between one set of PID values and another. Gain scheduling may be used in very non-linear systems where the control process exhibits large changes in response time or sensitivity, see Figure 9-5 below. This may occur, for example, over a wide range of PV, or between heating or cooling where the rates of response may be significantly different. The number of sets depends on the non-linearity of the system. Each PID set is chosen to operate over a limited (approximately linear) range.

In the case of the 2604 controller, this is done at a presettable strategy defined by the parameter 'Schedule Type' found in the *Loop SETUP/PID* page in configuration level. The choices are:

- PV The transfer between one set and the next depends on the value of the PV
- SP The transfer between one set and the next depends on the value of the SP
- Error The transfer between one set and the next depends on the value of the error
- OP The transfer between one set and the next depends on the value of the OP demand
- Set The PID set can be selected manually
- Rem The transfer between one set and the next depends on the value from a remote source for example, a digital input
- Sched IP To a parameter chosen by the user.

The 2604 controller has six sets of PID values - the maximum number which you may wish to use is set up in *Loop SETUP/PID* 'Num of Sets' parameter. You can select the active set from:

1. A digital input
2. A parameter in the *Loop Setup(PID)* page
3. Or you can transfer automatically in gain scheduling mode.

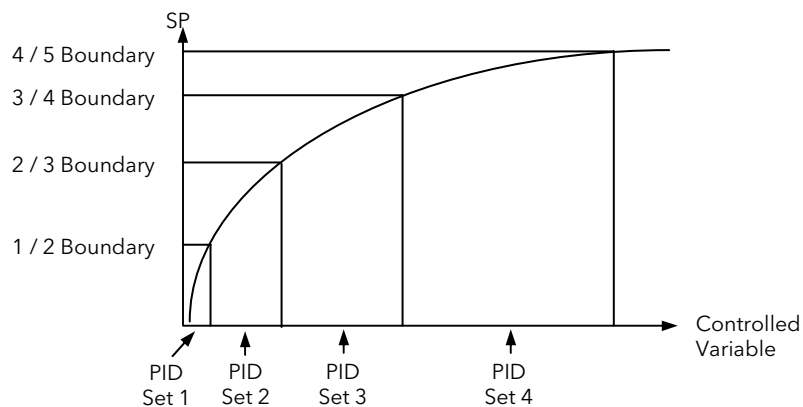


Figure 10-5: Gain Scheduling in a Non-Linear System

10.5.1 To Configure Gain Scheduling:-

Do This	This Is The Display You Should See	Additional Notes
1. From any display press as many times as necessary to select ' LP1 SETUP '		Alternatives are <i>LP2</i> and <i>LP3</i> . These only appear in the list if configured
2. Press or to ' PID Page '		
3. Press as many times as necessary to select ' Schedule Type '.		The choices are shown in the table in 9.4
4. Press or to select the gain scheduling type to use		The following table lists further parameters in this page. Press to select each parameter in turn. If the parameter is preceded by , press to change its value

Gain scheduling is uni-directional acting on the magnitude of the scheduling variables.

The PID, Cutback Low and High, Manual Reset, Cool Gain, Analogue Value, Output High and Low values must now be set up for each gain scheduling set.

Tuning the PID parameters when using gain scheduling is described further in Chapter 10.

10.5.2 PID Parameters

Table Number: 9.5.2. These parameters allow you to configure PID sets		LP1 SETUP (PID Page)		
Parameter Name	Parameter Description	Value	Default	Access Level
FF Offset	Feedforward offset value			R/O L3
FF Prop Band	Feedforward proportional band			R/O L3
FF Trim Lim	Feedforward trim limit			R/O L3
Remote FFwd	Remote feedforward	±100		L3
The above four parameters are only shown if FF Type (LP1 SETUP/Options) = Remote, SP or PV FF				
Rem Sched IP	Remote input Only shown if Schedule Type (below) = Rem Sched IP	Display range		L3
Loop Brk Time	Loop break time	Off On		L3
AutoDroop Comp Note 1	Manual reset when Integral turned off	Manual Calc		L3
Control Hold	Control hold flag. Freezes the control output	No Yes		L3
Integral Hold	Integral hold flag	No Yes		L3
Schedule Type	Scheduling type	Off Set SP PV Error OP Rem Sched IP Wired	Off	Conf
Num of Sets	Number of PID sets to use	1 to 6	1	Conf
Active PID Set	The PID set in current use	PID Set 1 to 6		R/O L1
Active An Val	Displays the current analogue value being used			R/O L1
1/2 Boundary	Sets the level at which PID set 1 changes to PID set 2	Range units		L3
2/3 Boundary	Sets the level at which PID set 2 changes to PID set 3	Range units		L3
3/4 Boundary	Sets the level at which PID set 3 changes to PID set 4	Range units		L3
4/5 Boundary	Sets the level at which PID set 4 changes to PID set 5	Range units		L3
5/6 Boundary	Sets the level at which PID set 5 changes to PID set 6	Range units		L3
The boundary parameters do not appear if 'Schedule Type' = 'Set'				
Prop Band 1	Proportional Band Set 1	1 to 9999.9 eng units	20	L1
Integral 1	Integral Time Set 1	Off to 999.9 secs or mins	360	L1
Derivative 1	Derivative Time Set 1		60	L1
Cutback Low 1	Cutback Low Set 1	Auto to display range		L1
Cutback High 1	Cutback High Set 1			L1
Manual Reset 1 Note 1	Manual Reset Set 1 (only applies to a PD controller)	Off, -100.0 to +100.0		L1
Cool Gain 1	Relative cool gain set 1 Only present if ch 1 and ch 2 are configured in the same loop	0.1 to 10	1	L1
An Value 1	Analogue value (set 1)			L3
OP Hi Limit 1	Output high limit 1	± 100		
OP Lo Limit 1	Output low limit 1	± 100		
The above ten parameters are repeated for sets 2 to 6 if the number of PID sets has been configured to 2 to 6 respectively.				

Note 1: Autodroop Compensation is used when the integral term is set to 'Off'. Under these conditions the controller will reach a steady state but is likely to control with an error.

When 'Autodroop Compensation' = 'Manual' the 'Manual Reset' parameter can be adjusted to compensate. The effect is to add or subtract a small amount of power manually into the load or actuator.

When 'Autodroop Compensation' = 'Calc' a value is calculated for the 'Manual Reset' which automatically sets the power level. Note that this is a 'snapshot' taken at a particular control point. If the SP is changed, however, the 'Manual Reset' will re-calculate.

Autodroop Compensation may be used in systems which have a very long time of response where it may not be possible to set a long enough integral time constant. Such systems usually operate at a fixed set of conditions so that a once only calculation or manual setting of the 'Manual Reset' can be acceptable.

☺ Manual Reset should be set to 0 when the integral term is set to a value.

10.5.3 PID (Aux) Parameters

Table Number: 9.5.3.		These parameters allow you to set up the PID sets.(Override & Cascade only)		LP1 SETUP PID(Aux) Page	
Parameter Name	Parameter Description	Value	Default	Access Level	
Rem Sched IP	Remote input Only shown if Schedule Type = Rem Sched IP	Display range		L3	
Control Hold	Aux. Control hold flag. Freezes the control output	No Yes		L3	
Integral Hold	Aux. Integral hold flag	No Yes		L3	
Schedule Type	Scheduling type	As main loop	Off	Conf	
Num of Sets	Number of PID sets to use	1 to 3	1	Conf	
Active PID Set	The PID set in current use	PID set 1 - 3		L1	
Active An Val	Active analogue value			R/O L3	
1/2 Boundary	Sets the level at which PID set 1 changes to PID set 2	Range units		L3	
2/3 Boundary	Sets the level at which PID set 2 changes to PID set 3	Range units		L3	
The boundary parameters do not appear if 'Schedule Type' = 'Set'					
Prop Band 1	Proportional Band Set 1	1 to 9999.9 eng units	20	L1	
Integral 1	Integral Time Set 1	Off to 999.9 secs or mins	360	L1	
Derivative 1	Derivative Time Set 1		60	L1	
Cutback Low 1	Cutback Low Set 1	Auto to display limit		L1	
Cutback High 1	Cutback High Set 1			L1	
Manual Reset 1	Manual Reset Set 1 (only applies to a PD controller)	Off, -100.0 to +100.0		L1	
Cool Gain 1	Relative cool gain set 1 Only present if ch 1 and ch 2 are configured in the same loop	0.1 to 10	1	L1	
An Value 1	Analogue value Set 1	Disp range		L3	
OP Hi Limit 1	Output high limit 1	± 100			
OP Lo Limit 1	Output low limit 1	± 100			
The above ten parameters are repeated for set 2 and again for set 3 if the number of PID sets has been configured to 2 or 3 respectively.					

This table does not appear if the Loop Type is Single or Ratio.

These tables are repeated for *Loop 2* and *Loop 3* if these have been configured

10.6 OUTPUT PARAMETERS

Typically the output(s) of the PID function block are wired to:

- The standard relay or logic outputs, configured for on/off or time proportioning pulses
- Relay, triac or logic output module, configured for on/off or time proportioning pulses
- Analogue output module, configured for Volts or mA

10.6.1 Table of Output Parameters

Table Number: 9.6.1		This list allows you to set up the parameters which control the output to the plant		LP1 SETUP (Output Page)	
Parameter Name	Parameter Description	Value	Default	Access Level	
Loop Mode	Allows the controller to be switched into manual	Auto Manual			
OP Low Limit	Sets a low limit on an analogue output signal	-100% to 100%		L3	
OP High Limit	Sets a high limit on an analogue output signal	-100% to 100%	100	L3	
OP Rate Limit	Sets the rate at which the output value changes	Off to 99.99 %/sec		L3	
OP Rate Lim En	Output rate limit enable	Off On	Off	L3	
Forced OP	Sets the output value when the controller is in manual - alternative to bumpless transfer	-100% to 100%		L3	
SBrk OP	Sets the level of the output in sensor break	-100% to 100%		L3	
CH1 OP	Reads the current value of channel 1 output	-100% to 100%		R/O	
Ch1 Hysteresis	Only shown if the output relay 1 is configured as on/off. It sets the difference between relay on and relay off.	Off to 9999.9		L3	
Ch1 Min Pulse	Output minimum on time (on/off control)			L3	
The above three parameters are repeated for channel 2					
Deadband On/Off control only	Deadband between ch1 and ch2. Only applies if both ch1 and ch2 are configured	Off to 100.0		L3	
Target OP	Target output power	-100 to 100%		L1	
Rem Lo OP Lim	Remote low power limit	-100% to 100%		L3	
Rem Hi OP Lim	Remote high power limit	-100% to 100%		L3	
Power FF Val	Current value of power feedforward			L3	
Ena OP Track	Output track enable	No Yes		L3	
OP Track Value	Track input			L3	
Ena Aux OP Trk	Auxiliary Output track enable	No Yes		L3	
Aux OP Track	Auxiliary Track input	Display range		L3	

10.7 MOTORISED VALVE CONTROL

The 2604 controller can be used for motorised valve control as an alternative to the standard PID control algorithm. This algorithm is designed specifically for positioning motorised valves. It operates in boundless or bounded mode as configured by the 'Control Type' parameter in Table 9.1.1. Boundless VP control does not require a position feedback potentiometer for control purposes. Bounded VP control requires a feedback potentiometer as part of the control algorithm. Note, however that a potentiometer may be used with boundless mode but it is used solely for indication of the valve position and is not used as part of the control algorithm. The control is performed by delivering a 'raise' pulse, a 'lower' pulse or no pulse at all in response to the control demand signal via raise and lower relay or triac outputs.

10.7.1 Motor Parameters

Table Number: 9.7.1.		This list allows you to set up the motor interface parameters for a valve positioning output. This page only appears if a motor valve positioning output is configured. See Section 9.1.1. (Control Type)		LP1 SETUP (Motor Page)	
Parameter Name	Parameter Description	Value	Default	Access Level	
Travel Time	This parameter is set to match the time taken for the motor to travel from fully closed to fully open	0:00:00.1	0:01:00:0	L3	
Inertia	This parameter is set to match the inertia (if any) of the motor	Off to 0:00:00.1	0:00:20:0	L3	
Backlash	This parameter compensates for any backlash which may exist in the linkages	Off to 0:00:00.1	0:00:20:0	L3	
Min Pulse Time	Sets the minimum on time of the signal which drives the motor	Auto to 0:00:00.1	Auto = 0:00:00:2	L3	
VP Pot Lo Lim ⁽¹⁾	Adjusts the valve position low limit in bounded mode set by the potentiometer	0 to 100%	0%	L3	
VP Pot Hi Lim ⁽¹⁾	Adjusts the valve position high limit in bounded mode set by the potentiometer	0 to 100%	100%	L3	
VP SBrk OP	Sets the action of the valve in boundless mode Only appears in boundless mode, i.e. 'Control Type' = VP-Ch1 Only	VP Pos Lo to VP Pos Hi		L3	
VP SBrk Action	Sets the action of the valve if the potentiometer becomes disconnected in bounded mode	Rest Up Down		L3	
Valve Position	Indicates the position of the valve	0 to 100%		R/O	
Enable Pot Cal ⁽¹⁾	Pot input calibration enable	Off On	Off	L3	

Note 1

These three parameters are only displayed if the potentiometer is soft wired, i.e. 'Pot IP Src' is wired to a parameter.


10.8 DIAGNOSTICS

Diagnostic parameters are available at all levels, are read only and provide information on the current operating conditions of the controller.






10.8.1 Diagnostic Page

Table Number: 9.8.1. This list allows you to interrogate operating conditions of the loop		LP 1 SETUP (Diagnostic Page)		
Parameter Name	Parameter Description	Value	Default	Access Level
LP1 PV	Process Variable	Display range		L1
LP1A PV	Auxiliary Process Variable			L1
Working SP	The value of the working setpoint			L1
Working OP	The value of the working output	-100 to 100		L1
Error	Value of main loop error (PV - SP)	Display range		L1
Aux Error	Value of the auxiliary loop error (PV - SP)	-9999 to 9999		R/O
P OP	Proportional component of the output	-999 to 9999		R/O
Aux P OP	Proportional component of the auxiliary loop output	-999 to 9999		R/O
I OP	Integral component of the output	-999 to 9999		R/O
Aux I OP	Integral component of the auxiliary loop output	-999 to 9999		R/O
D OP	Derivative component of the output	-999 to 9999		R/O
Aux D OP	Derivative component of the auxiliary loop output	-999 to 9999		R/O
FF OP	Feedforward component of output	-9999 to 9999		R/O
SRL Complete	Setpoint rate limit complete			R/O
VP Velocity	VP output velocity	-100 to 100		R/O
Loop Brk Stat	Loop break status flag	No Yes		R/O
Ext FBack	External Feedback			R/O
Aux Ext FBack	Auxiliary External Feedback			R/O

10.9 DISPLAY

In operator levels the LOOP button (section 1.4.3) allows the operator to choose an overview of *LP1*, *LP2* or *LP3* (if these loops have been enabled). Pressing the  button when the loop overview is being displayed will scroll through a list of up to 10 parameters which may be in common use for the particular application. This section shows how to 'promote' these parameters.

10.9.1 Display Page

Table Number: 9.9.1.		This list configures which parameters will be shown in operator level when the     button is pressed		LP 1 SETUP (Display Page)	
Parameter Name	Parameter Description	Value	Default	Access Level	
Loop Name	Loop name chosen from User Text, see Section 5.2.6.	Default Text or 01 to 50 User Text	Default Text	Conf	
Param Promote	Selects the parameter which is to be promoted to the Loop Summary.	1 to 10		Conf	
Param Address	The modbus address of the parameter selected by 'Param Promote'. See Appendix D.1.	Modbus address		Conf	
Param Name	A name can be selected from User Text (see 5.2.6.) and replaces the number of the 'Param Promote' parameter.	Default Text or 01 to 50 User Text		Conf	
Param Access	Sets the read/write access level of the 'Param Promote' parameter.	Lev 1 Read Only Lev 1 Alterable Lev 2 Read Only Lev 2 Alterable		Conf	
Parameters which have been promoted using 'Param Promote' are listed at the end of this table as a preview of those which will appear in the Summary page in operation levels. For example:- If 'Param Address' = '10247:Sum.PrNam' the following will be displayed:-					
					Prg:  Reset Program 1

10.10 CASCADE CONTROL

10.10.1 Overview

Cascade control is classified as an advanced control technique used, for example, to enable processes with long time constants to be controlled with the fastest possible response to process disturbances, including setpoint changes, whilst still minimising the potential for overshoot. It is a combination of two PID controllers, where the output signal from one (the master) forms the setpoint for the other (the slave). For cascade control to be effective the slave loop should be more responsive than the master.

10.10.2 Full Scale Cascade Mode

An example of Full Scale Cascade Mode is shown in Figure 9-6. A controller, the slave, regulates the fuel flow to a furnace. A second controller, the master, measures the temperature but, instead of regulating the valve, it regulates the setpoint of the flow controller. In full scale mode the scaling is such that the master is allowed to adjust the slave by 0-100%.

Remote feedforward is a user defined, wireable parameter. It may be used if there is a requirement for some additional parameter, for example an analogue input, to trim the master PID output value before the slave setpoint is applied. An application may be a liquid temperature control system using cascade control of heater temperature where variations in control rate can be directly fed forward into the slave loop, modifying heater temperature and giving rapid compensation

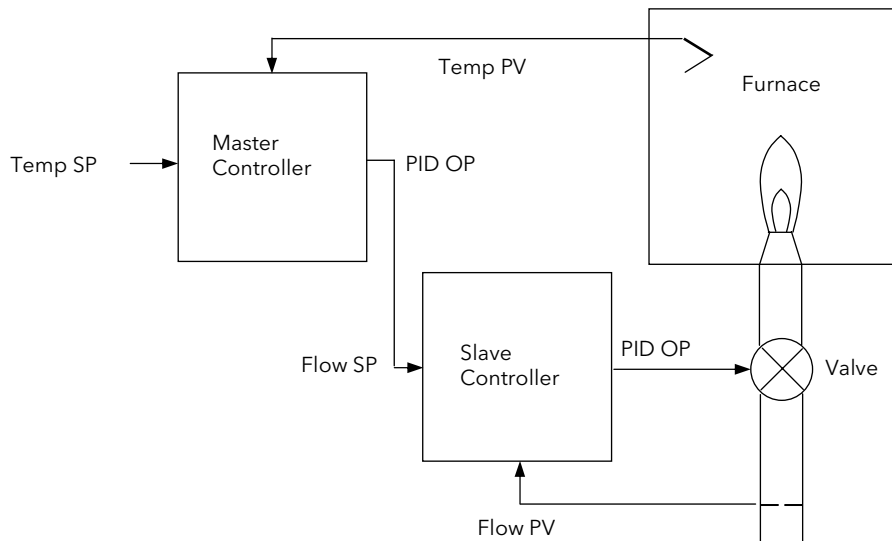


Figure 10-6: Full Scale Cascade Control

10.10.3 Trim Mode

In this example the slave controls the temperature within a furnace. The master is measuring the temperature of the workpiece and controlling the temperature of the slave. In this case the master trims the setpoint of the slave rather than controlling it directly. By limiting the amount of trim the temperature of the furnace will remain within bounds.

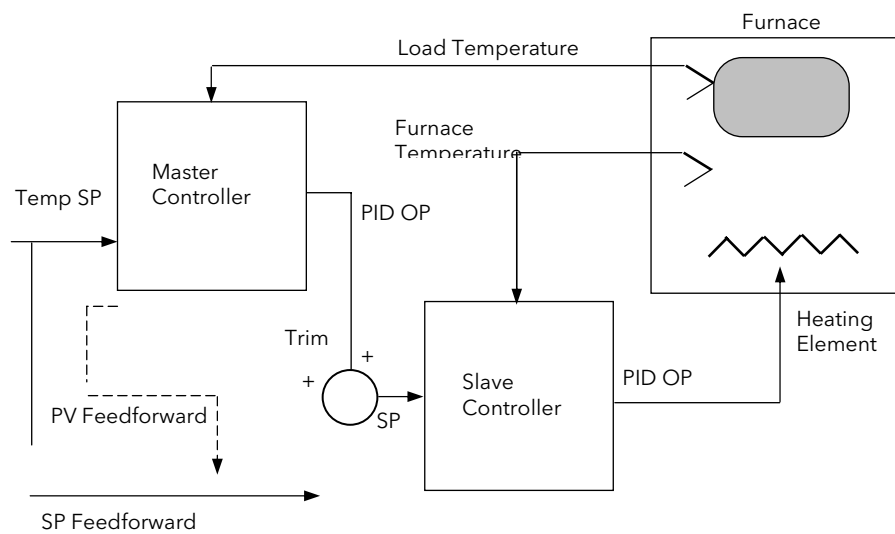
Feedforward allows either the master PV, master SP or a user defined variable (CSD FFwd Src) to be fed forward so that it directly influences the slave setpoint.

A typical application for SP feedforward could be in a heat treatment furnace, where it can be used to extend the life of heating elements by limiting their maximum operating temperature.

An application using PV feedforward could be in autoclaves or reactor vessels where it is sometimes required to protect the product from excessive temperature gradients (also referred to as Delta T Control). The effect of this is to limit the furnace temperature to a band around the target temperature.

Feedforward can also be a user defined variable in trim mode in the same way as full scale mode

The implementation of cascade control in the 2604 is available as a standard option. ie it is not necessary to order a dual loop controller to perform cascade control.



SP Feedforward or PV
Feedforward may be selected

Figure 10-7: Cascade Trim Control

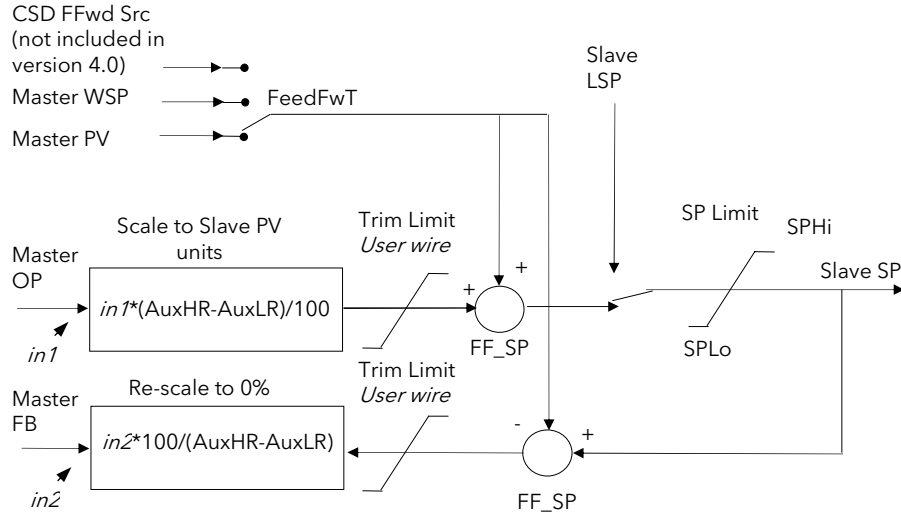
10.10.4 Auto/Manual Operation in Cascade

Auto/Manual operates on both master and slave loops.

When the controller is placed in manual the slave working setpoint will track the value of the slave process value continually, therefore ensuring bumpless transfer.

When cascade is deactivated the master loop will monitor the setpoint of the slave loop and provide a smooth transition of output power when the loop moves back to cascade mode.

10.10.5 Cascade Controller Block Diagrams



Note:
This diagram applies to controllers with software version 4.0 or greater
For earlier versions, see Appendix E

Figure 10-8: Cascade Controller in Trim Mode

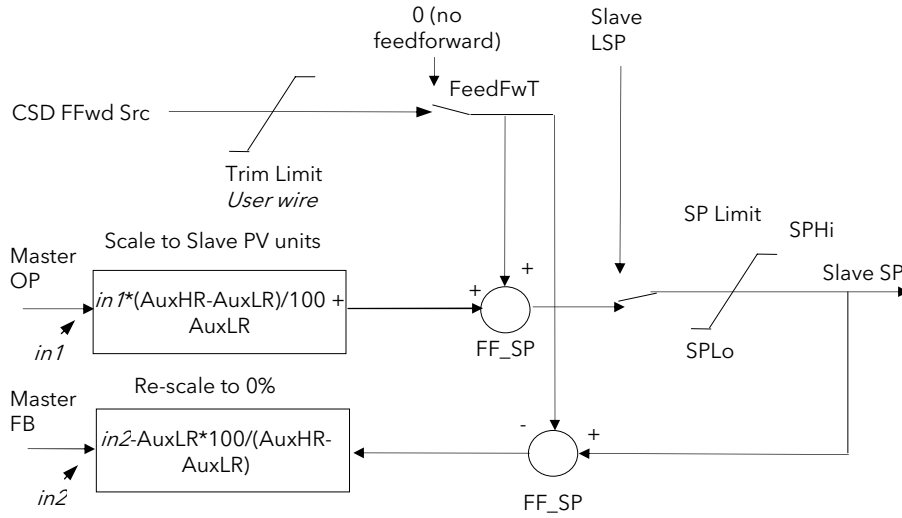


Figure 10-9: Cascade Controller in Full Scale Mode

11. LOOP SETUP (WIRING PAGE) FOR CASCADE LOOP

A controller is configured for cascade operation if 'Loop Type' = 'Cascade' in 'LOOP SETUP(Options)' page, (Table 9.1.1.).

Table Number: 9.10.6.		These parameters allow you to soft wire between function blocks.		LP1 SETUP Wiring Page	
Parameter Name	Parameter Description	Value	Default	Access Level	
PV Src	Process variable source	Modbus address	05108: PVIn.Val	Conf	
Aux PV Src	Auxiliary PV source	Modbus address		Conf	
Manual OP Sr	Target OP power source	Modbus address		Conf	
OPRtLim En S	OP rate limit enable source	Modbus address		Conf	
Aux LSP Src	Auxiliary local SP source	Modbus address		Conf	
Casc Disable S	Cascade disable source	Modbus address		Conf	
Casc FFwd Src	Casc. feedforward source	Modbus address		Conf	
The above parameter does not appear if FF Type (Table 9.1.1.) = None					
Casc TrimHi Src	Casc. FF trim high limit source	Modbus address		Conf	
Casc TrimLo Src	Casc. FF trim low limit source	Modbus address		Conf	
Ctrl Hold Src	Freeze control flag source	Modbus address		Conf	
AuxCtrlHold Src	Aux. freeze control flag src	Modbus address		Conf	
Integr Hld Src	Integral hold flag source	Modbus address		Conf	
Aux I Hold Src	Aux. Integral hold flag src	Modbus address		Conf	
Man Mode Src	Auto/manual select source	Modbus address		Conf	
Pot IP Src	Pot position source	Modbus address		Conf	
Rem FFwd Src	Remote feedforward src	Modbus address		Conf	
Rem Hi OP Src	Remote hi power limit src	Modbus address		Conf	
Rem Lo OP Sr	Remote lo power limit src	Modbus address		Conf	
The above two parameters do not appear if Control Type (Table 9.1.1.) = On/Off					
Rem SP Ena S	Remote SP enable source	Modbus address		Conf	
Remote SP Sr	Remote setpoint source	Modbus address		Conf	
SP Select Sr	Internal SP select source	Modbus address		Conf	
SP1 Src	Setpoint 1 source	Modbus address		Conf	
SP2 Src	Setpoint 2 source	Modbus address		Conf	
Rt Lim Dis Src	SP rate limit disable source	Modbus address		Conf	
RtLim Src	SP rate limit source	Modbus address		Conf	
Rt Lim Hld Src	SP rate limit hold source	Modbus address		Conf	
Prog SP Src	LP1 PSP wire source	Modbus address		Conf	
PID Set Src	PID Set Source	Modbus address		Conf	
Aux PID Set Src	Auxiliary PID Set Source	Modbus address		Conf	
Power FF Src	Power feedforward source	Modbus address		Conf	
Track Enab Src	OP track enable source	Modbus address		Conf	
Track Src	Track output source	Modbus address		Conf	
Aux Trk En S	Aux. OP track enable src	Modbus address		Conf	
Aux Trk Src	Aux. track output source	Modbus address		Conf	
Ext FBack Src	External feedback source	Modbus address		Conf	
AuxExtFBck Src	Auxiliary external feedback source	Modbus address		Conf	
Prop Band Src	Proportional band source	Modbus address		Conf	
Integral Src	Integral source	Modbus address		Conf	
Derivative Src	Derivative source	Modbus address		Conf	
Aux Prop Src	Auxiliary loop proportional band source	Modbus address		Conf	
Aux Integral Src	Auxiliary loop integral source	Modbus address		Conf	
Aux Derivative Src	Auxiliary loop derivative source	Modbus address		Conf	

11.1.1 Cascade Parameters

Table Number: 9.10.7.		This list only appears if cascade is configured, (see section 9.1) and allows you to set up parameters specific to cascade controllers.		<i>LP1 SETUP</i> (Cascade Page)	
Parameter Name	Parameter Description	Value	Default	Access Level	
Cascade Mode	Cascade mode	Full Scale FF Full Scale Trim PV FF Trim SP FF		Conf	
Disable CSD	Cascade disable status. (It is sometimes useful to disable cascade when starting a process. This also returns the controller to single loop control using the local SP.)	Off On		L1.	
CSD TrimLo	Cascade low trim limit				
CSD TrimHi	Cascade high trim limit				
CSD FF Value	Cascade feedforward value i.e. The value being fed forward	Range of signal being fed forward		L3	
Work FF Value	Working feedforward value			R/O	
Master FB	Cascade master PID feedback value	Range of slave loop		R/O	

11.1.2 Cascade Wiring Example

This example shows how to configure Loop 1 to be a simple cascade controller. The master PV is connected to the Main PV input and the slave PV is connected to a PV Input module fitted in Slot 3. The control output is a 4-20mA signal which uses a DC control module fitted in Slot 1.

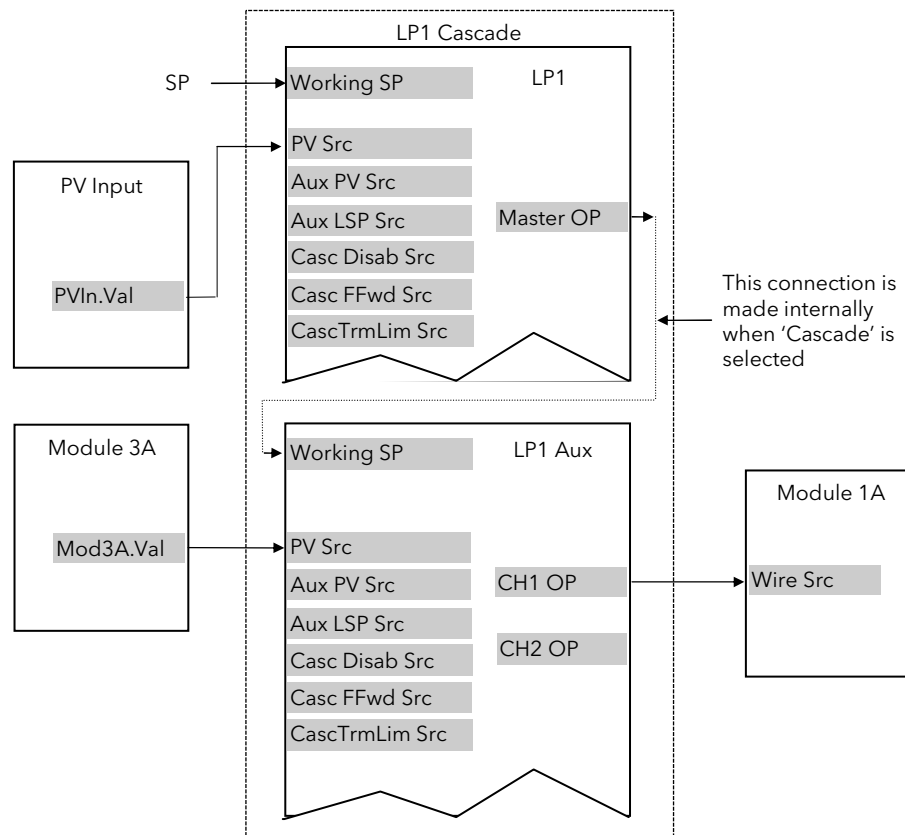


Figure 11-1: Wiring for Simple Cascade Control Loop

11.1.2.1 Implementation

1. In LP1 SETUP / Options set 'Loop Type' = Cascade
2. In LP1 SETUP / Wiring set 'PV Src' = 05108: PVIn.Val (Appendix D)
This connects the PV input to the master PV of the cascade loop
3. In LP1 SETUP / Wiring Page set 'Aux PV Src' = 04468: Mod3A.Val (Appendix D)
This connects the PV input from Module 3 to the slave PV of the cascade loop
4. In MODULE IO / Module 1 A Page set 'Wire Src' = 00013: L1.Ch1.OP (Appendix D)
This connects channel 1(heat) control to the DC output module

See Appendix D for list of Modbus addresses.

☺ **Tip:-** See 'Copy and Paste' description in Chapter 3.

11.2 RATIO CONTROL

11.2.1 Overview

Ratio Control is a technique used to control a process variable at a setpoint which is calculated as a proportion of a second (lead) input. The ratio setpoint determines the proportion of the lead value that is to be used as the actual control setpoint. The ratio setpoint can be applied as either a multiplier or as a divisor to the second input.

A typical application is in gas fired furnaces where in order to achieve efficient combustion, the gas and air flow supplied to the burners needs to be maintained at a constant ratio.

11.2.2 Basic Ratio Control

The 2604 contains a ratio control function block which can be used in any control loop. Figure 9.11 shows a block diagram of a simple ratio controller. The lead PV is multiplied or divided by the ratio setpoint to calculate the desired control setpoint. Prior to the setpoint calculation, the ratio setpoint can be offset by the ratio trim value and must obey the overall ratio setpoint operating limits. Another useful feature is the automatic calculation of the actual measured ratio which is then available to be displayed on the controller front panel.

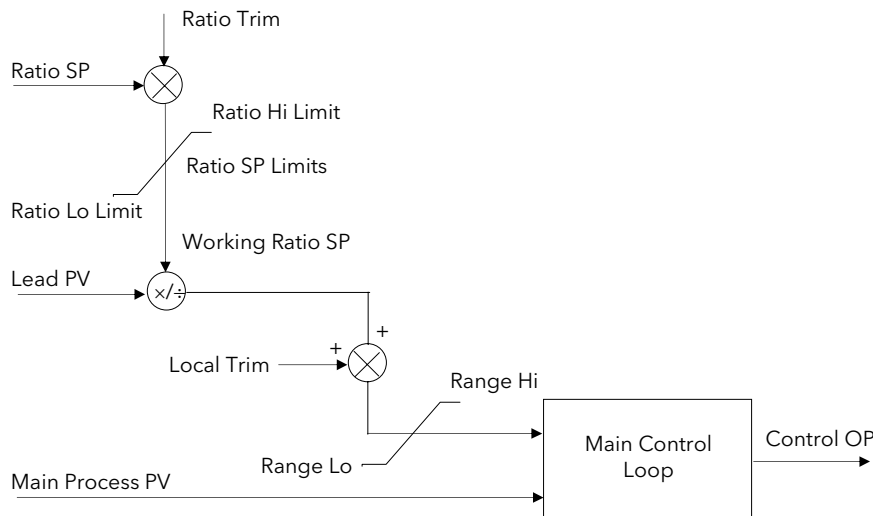


Figure 11-2: Simple Ratio Control Block Diagram

The measured ratio is calculated from the Lead PV and the Process PV. It is also possible to enable 'Ratio Track'. If 'Enable Ratio' is set to 'Off' and Ratio Track is set to 'On', then the Ratio SP will track the measured ratio. This feature allows the user to set the Ratio SP according to the condition of the process.

11.2.3 Controller Configured For Ratio

A controller is configured for ratio operation if 'Loop Type' = 'Ratio' in 'LOOP SETUP(Options)' page.

Table Number: 9.11.3. These parameters allow you to soft wire between function blocks.			LP1 SETUP Wiring Page	
Parameter Name	Parameter Description	Value	Default	Access Level
PV Src	Process variable source	Modbus address	05108: PVIn.Val	Conf
Manual OP Sr	Target OP power source	Modbus address		Conf
OPRtLim En S	OP rate limit enable src	Modbus address		Conf
Lead PV Src	Lead PV source	Modbus address		Conf
Ratio SP Src	Ratio setpoint source	Modbus address		Conf
Ratio Trim Src	Ratio trim source	Modbus address		Conf
Ratio Enab Src	Ratio enable source	Modbus address		Conf
Ctrl Hold Src	Freeze control flag source	Modbus address		Conf
Integr Hld Src	Integral hold flag source	Modbus address		Conf
Man Mode Src	Auto/manual select source	Modbus address		Conf
Pot IP Src	Pot position source	Modbus address		Conf
Rem FFwd Sr	Remote feedforward src	Modbus address		Conf

Rem Hi OP Src	Remote high power limit src	Modbus address		Conf
Rem Lo OP Src	Remote low power limit src	Modbus address		Conf
The above two parameters do not appear if Control Type (Table 9.1.1.) = On/Off				
Rem SP Ena S	Remote SP enable source	Modbus address		Conf
Remote SP Sr	Remote setpoint source	Modbus address		Conf
SP Select Sr	Internal SP select source	Modbus address		Conf
SP1 Src	Setpoint 1 source	Modbus address		Conf
SP2 Src	Setpoint 2 source	Modbus address		Conf
Rt Lim Dis Src	SP rate limit disable src	Modbus address		Conf
Rt Lim Src	Rate limit source	Modbus address		Conf
Rt Lim Hld Src	SP rate limit hold source	Modbus address		Conf
Prog SP Src	LP1 PSP wire source	Modbus address		Conf
PID Set Src	PID Set Source	Modbus address		Conf
Power FF Src	Power feedforward source	Modbus address		Conf
Track Enab Src	OP track enable source	Modbus address		Conf
Track Src	Track output source	Modbus address		Conf
Ext FBack Src	External feedback source	Modbus address		Conf
Prop Band Src	Proportional band source	Modbus address		Conf
Integral Src	Integral source	Modbus address		Conf
Derivative Src	Derivative source	Modbus address		Conf
Aux Prop Src	Auxiliary loop proportional band source	Modbus address		Conf
Aux Integral Src	Auxiliary loop integral source	Modbus address		Conf
Aux Derivative Src	Auxiliary loop derivative source	Modbus address		Conf

11.2.4 Ratio Parameters

Table Number: 9.11.4.		This list only appears if ratio is configured (see section 9.1.1.) and allows you to set up parameters specific to ratio controllers.		LP1 SETUP (Ratio Page)
Parameter Name	Parameter Description	Value	Default	Access Level
Ratio Resol	Ratio display resolution	XXXXX XXXX.X XXX.XX XX.XXX		Conf
Ratio Type	Ratio type	Divide Multiply		Conf
Lead PV	The value of the lead process variable			L1
Measured Ratio	Measured Ratio			R/O
Work Ratio SP	Ratio working setpoint			R/O
Ratio Lo Lim	Ratio setpoint low limit			L3
Ratio Hi Lim	Ratio setpoint high limit			L3
Ratio SP	Ratio setpoint			L1
Ratio Trim	Ratio trim value			L1
Enable Ratio	Ratio enable	Off On		L1
Ratio Track	Ratio track mode	Off On		Conf

11.2.5 Ratio Wiring Example

This example shows how to configure Loop 1 to be a simple ratio controller. The main PV is connected to the PV Input (rear terminals V+ & V-) and the lead PV is connected to the Analogue Input (rear terminals BA & BB). The control output is a valve position signal which uses a dual triac control module fitted in Slot 1.

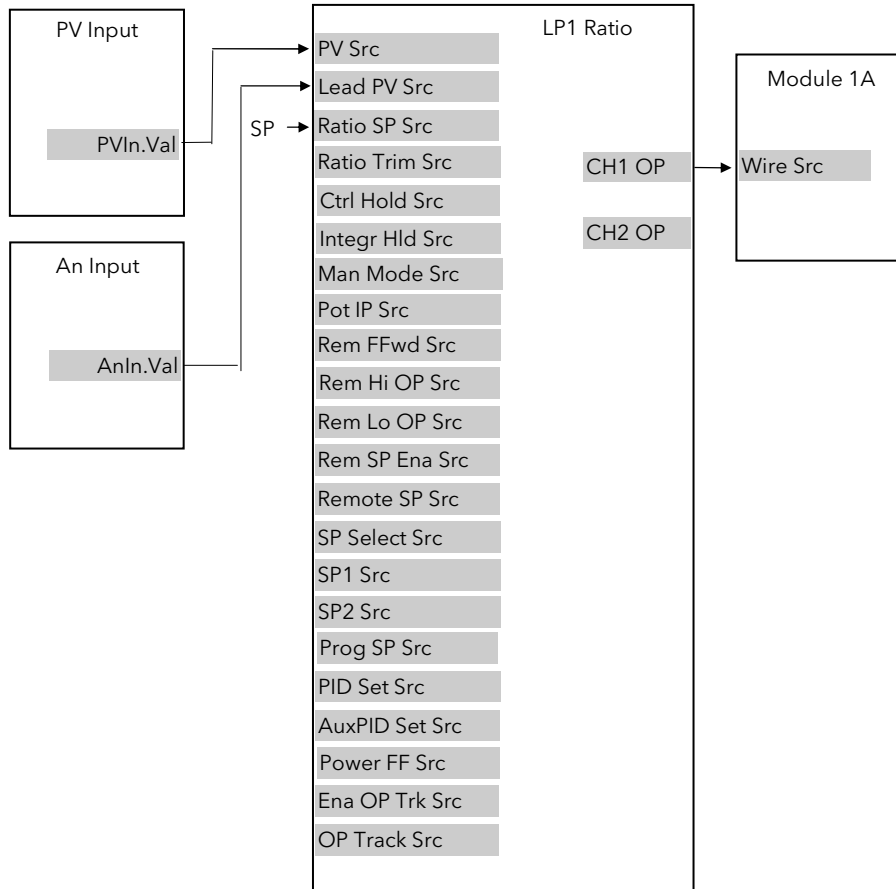


Figure 11-3: Wiring for Simple Ratio Control Loop

11.2.5.1 Implementation

1. In LP1 SETUP / Options set 'Loop Type' = Ratio
2. In LP1 SETUP / Ratio Page set 'Enable Ratio' = On
Set other parameters as required
3. In LP1 SETUP / Wiring set 'PV Src' = 05108: PVIn.Val
(Appendix D)
This connects the PV input to the main PV of the ratio loop
4. In LP1 SETUP / Wiring Page set 'Lead PV Src' = 05268: AnIn.Val (Appendix D)
This connects the lead PV input of the ratio loop from Analogue Input
5. In MODULE IO / Module 1 A Page set 'Wire Src = 00013: L1.Ch1.OP
(Appendix D)
This connects channel 1(heat) control to the Dual Triac output module

See Appendix D for list of Modbus addresses.

☺ **Tip:-** See 'Copy and Paste' description in Chapter 3.

11.3 OVERRIDE CONTROL

11.3.1 Overview

Override Control allows a secondary control loop to override the main control output in order to prevent an undesirable operating condition. The override function can be configured to operate in either minimum, maximum or select mode.

A typical example can be implemented in a heat treatment furnace with one thermocouple attached to the workpiece, and another situated close to the heating elements. Control of the furnace during the heating up period is regulated by the override (heating element) temperature controller which provides a safeguard against overheating. Control of the furnace will switch over to the workpiece temperature controller at some point when the temperature is near to its target setpoint. The exact point of switchover is determined automatically by the controller, and will be dependent on the selected PID terms.

11.3.2 Simple Override

Override control is available with analogue, time proportioning and ON/OFF control outputs. It is not available with valve position outputs. Figure 9.13 shows a simple override control loop. The main and override controller outputs are fed to a low signal selector. The override controller setpoint is set to a value somewhere above the normal operating setpoint, but below any safety interlocks.

There is only one Auto Manual switch for both loops. In manual mode the control outputs of both loops track the actual output, ensuring bumpless transfer when auto is selected. The transfer between main and override PID control is also bumpless.

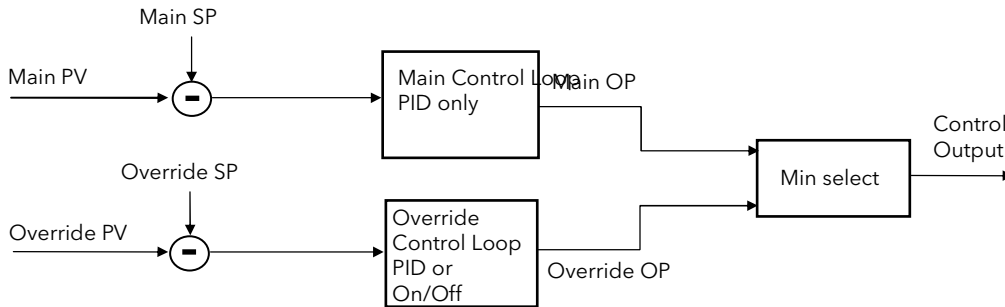


Figure 11-4: Simple Override Control (Select Minimum)

11.3.3 Controller Configured For Override

A controller is configured for override operation if 'Loop Type' = 'Override' in 'LOOP SETUP(Options)' page, (Table 9.1.1.).

Table Number: 9.12.3. These parameters allow you to soft wire between function blocks.			LP1 SETUP Wiring Page	
Parameter Name	Parameter Description	Value	Default	Access Level
PV Src	Process variable source	Modbus address	05108: PVIn.Val	Conf
Aux PV Src	Auxiliary PV source	Modbus address		Conf
Manual OP Sr	Target OP power source	Modbus address		Conf
OPRtLim En S	OP rate limit enable src	Modbus address		Conf
OPRtLim Src	OP rate limit src	Modbus address		Conf
Aux LSP Src	Auxiliary local SP source	Modbus address		Conf
Ctrl Hold Src	Freeze control flag source	Modbus address		Conf
AuxCtrlHold Sr	Aux freeze control flag src	Modbus address		Conf
Integr Hld Sr	Integral hold flag source	Modbus address		Conf
Aux I Hold Sr	Aux. Integral hold flag src	Modbus address		Conf
Man Mode Sr	Manual mode source	Modbus address		Conf
Active Lp Sr	Active loop source	Modbus address		Conf
OVR Disab Sr	Override disable source	Modbus address		Conf
OVR Trim Src	Override trim source	Modbus address		Conf

Pot IP Src	Pot position source	Modbus address		Conf
Rem FFwd Sr	Remote feedforward src	Modbus address		Conf
Rem Hi OP Src	Remote hi power limit src	Modbus address		Conf
Rem Lo OP Sr	Remote lo power limit src	Modbus address		Conf
The above two parameters do not appear if Control Type (Table 9.1.1.) = On/Off				
Rem SP Ena Src	Remote SP enable source	Modbus address		Conf
Remote SP Src	Remote setpoint source	Modbus address		Conf
SP Select Src	Internal SP select source	Modbus address		Conf
SP1 Src	Setpoint 1 source	Modbus address		Conf
SP2 Src	Setpoint 2 source	Modbus address		Conf
Rt Lim Dis Src	SP rate limit disable src	Modbus address		Conf
RtLim Src	SP rate limit src	Modbus address		Conf
Rt Lim Hld Src	SP rate limit hold source	Modbus address		Conf
Prog SP Src	LP1 PSP wire source	Modbus address		Conf
PID Set Src	PID Set Source	Modbus address		Conf
Aux PID Set Src	Auxiliary PID Set Source	Modbus address		Conf
Power FF Src	Power feedforward source	Modbus address		Conf
Track Enab Src	OP track enable source	Modbus address		Conf
Track Src	Track input source	Modbus address		Conf
Ext FBack Src	External feedback source	Modbus address		Conf
AuxExtFBck Src	Auxiliary external feedback source	Modbus address		Conf
Prop Band Src	Proportional band source	Modbus address		Conf
Integral Src	Integral source	Modbus address		Conf
Derivative Src	Derivative source	Modbus address		Conf
Aux Prop Src	Auxiliary loop proportional band source	Modbus address		Conf
Aux Integral Src	Auxiliary loop integral source	Modbus address		Conf
Aux Derivative Src	Auxiliary loop derivative source	Modbus address		Conf

11.3.4 Override Parameters

Table Number: 9.12.4.		This list only appears if override is configured (see section 9.1.1.) and allows you to set up parameters specific to override controllers		LP1 SETUP (Override Page)	
Parameter Name	Parameter Description	Value	Default	Access Level	
Override Type	Override type See Note 1	Minimum Maximum Select		Conf	
OVR Target SP	Override target setpoint	Display range			
Disable OVR	Disable override control. See Note 2.	No Yes		L1	
Active Loop	Displays the loop which is controlling at any time			L1	
OVR SP Trim	Override loop setpoint trim	Range limit		L1	
Main OP	Override main output	-100 to 100		R/O	
Override OP	Override output	-100 to 100		R/O	

Note 1:-

Minimum selects the lowest output power from the two loops to be the control output.

Maximum selects the highest output power from the two loops to be the control output.

Select allows either the main output or the override output to be used as the control output depending on the state of a digital input or via digital communications.

Note 2:-

The main control loop is active when Override control is disabled.

11.3.5 Override Wiring Example

This example shows how to configure Loop 1 to be a simple override furnace temperature controller. The main PV is connected to the PV Input (rear terminals V+ & V-) and the override PV is connected to a PV Input module fitted in slot 3 (rear terminals 3C & 3D). The control output is an analogue control module fitted in Slot 1.

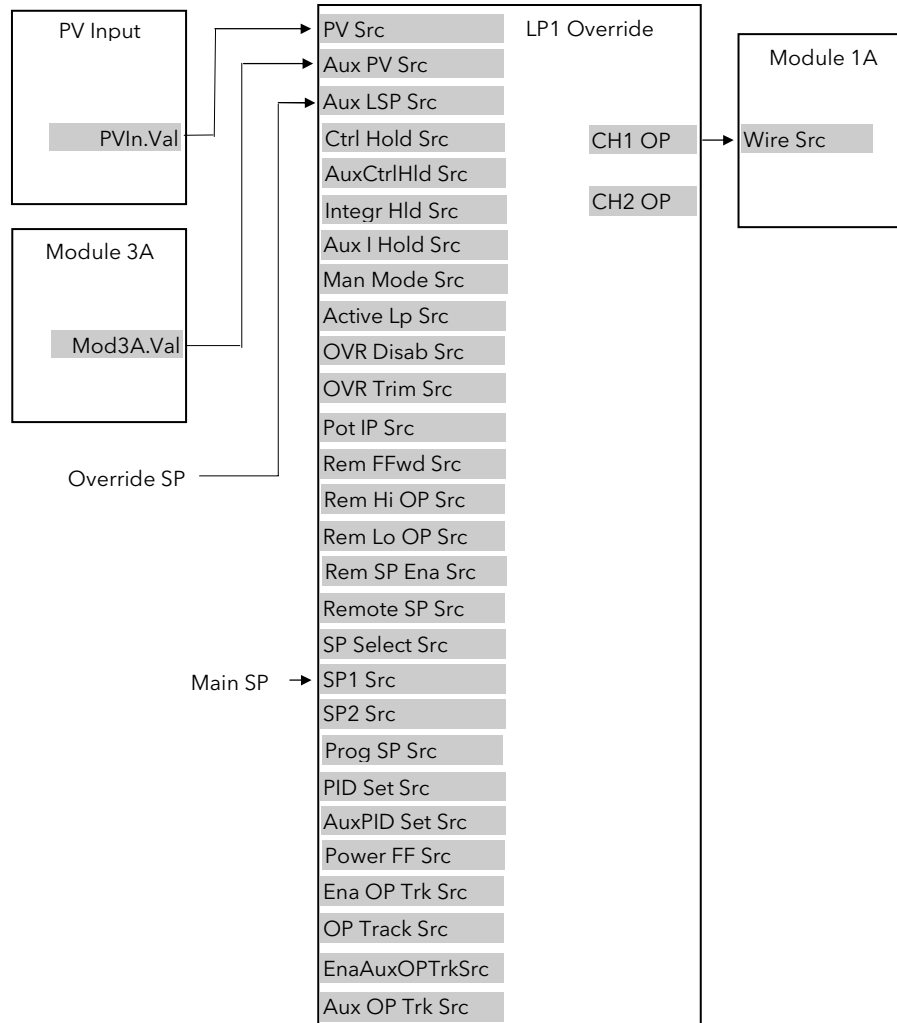


Figure 11-5: Wiring for Simple Override Control Loop

11.3.5.1 Implementation

- In LP1 SETUP / Options Page
 - set 'Loop Type' = Override
 - This action also connects the main SP and override SP to SP1 and SP2 respectively.*
- In LP1 SETUP / Override Page
 - set 'Override Type' = Minimum
 - Set other parameters as required
- In LP1 SETUP / Wiring
 - set 'PV Src' = 05108: PVIn.Val (Appendix D)
 - This connects the PV input to the main PV of the override loop*
- In LP1 SETUP / Wiring Page
 - set 'Aux PV Src' = 04468: Mod3A.Val (Appendix D)
 - This connects the override PV input of the override loop from Analogue Input*
- In MODULE IO / Module 1 A Page
 - set 'Wire Src' = 00013: L1.Ch1.OP (Appendix D)
 - This connects channel 1(heat) control to the Analogue output module*

See Appendix D for list of Modbus addresses.

Tip:- See 'Copy and Paste' description in Chapter 3.

11.4 LOOP2 SET UP

All pages listed in the previous sections are repeated for Loop 2.

11.5 LOOP3 SET UP

All pages listed in the previous sections are repeated for Loop 3.

12.CHAPTER 12 TUNING

This chapter describes how to tune your controller to match the characteristics of the process under control.

There are five topics:

- WHAT IS TUNING?
- AUTOMATIC TUNING
- MANUAL TUNING
- GAIN SCHEDULING
- TUNING OF CASCADE LOOPS

This chapter should be read in conjunction with Chapter 9, Loop Set Up.

12.1 WHAT IS TUNING

In tuning, you match the characteristics of the controller to those of the process being controlled in order to obtain good control. Good control means:

- Stable, 'straight-line' control of the PV at setpoint without fluctuation
- No overshoot, or undershoot, of the PV setpoint
- Quick response to deviations from the setpoint caused by external disturbances, thereby rapidly restoring the PV to the setpoint value.

Tuning involves calculating and setting the value of the parameters listed in Table 10-1. These parameters appear in the *Loop Setup* (PID) list, see Chapter 9.

Parameter	Meaning or Function
Proportional band	The bandwidth, in display units or %, over which the output power is proportioned between minimum and maximum.
Integral time	Determines the time taken by the controller to remove steady-state error signals.
Derivative time	Determines how strongly the controller will react to the rate-of-change of the measured value.
High Cutback	The number of display units, above setpoint, at which the controller will increase the output power, in order to prevent undershoot on cool down.
Low cutback	The number of display units, below setpoint, at which the controller will cutback the output power, in order to prevent overshoot on heat up.
Cool gain	Only present if cooling has been configured and a module is fitted. Sets the cooling proportional band, which equals the proportional band value divided by the cool gain value.

Table 12-1: Tuning Parameters

12.2 AUTOMATIC TUNING

The 2604 controller uses a one-shot tuner which automatically sets up the initial values of the parameters listed in Table 10-1 on the previous page.

12.2.1 One-shot Tuning

The 'one-shot' tuner works by switching the output on and off to induce an oscillation in the measured value. From the amplitude and period of the oscillation, it calculates the tuning parameter values.

If the process cannot tolerate full heating or cooling being applied during tuning, then the levels can be restricted by setting the autotune high power limit ('Tune OH') and autotune low power limit ('Tune OL') in the AUTOTUNE parameters page (Table 10.3.2.). These limits are only applied during the autotune process. However, the measured value *must* oscillate to some degree for the tuner to be able to calculate values.


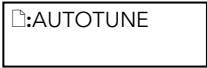

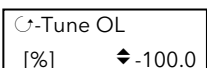


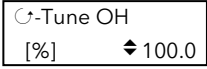

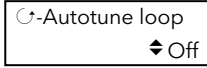


Under normal control the output power limits may be set by 'OP Low Limit' and 'OP High Limit' found in *LPx SETUP/Output* lists. If these limits are set to a lower value than the autotune limits, then the autotune high and low power limits will be clipped to the output limits as soon as Autotune is run.

A One-shot Tune can be performed at any time, but normally it is performed only once during the initial commissioning of the process. However, if the process under control subsequently becomes unstable (because its characteristics have changed), you can re-tune again for the new conditions.

It is best to start tuning with the process at ambient conditions and with the SP close to the normal operating level. This allows the tuner to calculate more accurately the low cutback and high cutback values which restrict the amount of overshoot, or undershoot.

12.3 TO AUTOTUNE CONTROL LOOP LP1

In most cases it will only be necessary to carry out the Autotune procedure when commissioning your controller.

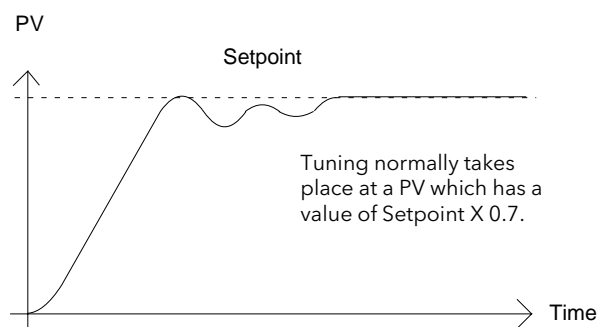
Do This	This Is The Display You Should See	Additional Notes
Set the setpoint to the value at which you will normally operate the process .		
1. From any display press  as many times as necessary to select 'AUTOTUNE'		Autotune page is at Level 3 by default, but can be promoted to L1 or L2. See 5.2.5.
2. Press  to select 'Tune OL'.		
3. Press  or  to select the minimum power limit during tuning		
4. Repeat 2 and 3 for 'Tune OH'		
5. Press  to select 'Autotune Loop'		The choices are:- LP1 LP1A LP1 Cascade
6. Press  or  to choose the loop to tune		These are repeated for Loops 2 and 3

The following now takes place:-

1. The controller induces an oscillation in the PV by first turning the output (power) on, and then off. The power is limited by 'Tune OL' and 'Tune OH'. These two parameters are defaulted to 0 and should be set to values which do not overload the process during tuning. These values are limited by the overall 'OP Low Limit' and 'OP High Limit' set in the Output Page. The first cycle is not complete until the measured value has reached the required setpoint.
2. After two cycles of oscillation the tuning is completed and the tuner switches itself off.
3. When the controller is autotuning the status of autotune is shown periodically on the relevant loop summary
4. The parameter 'Tune SP' is the setpoint value which the controller uses to tune. In a cascade loop this may be derived from the master or slave loops.
5. The parameter 'Stage Time' shows the time spent in any individual stage of the tuning process. If the time in any stage exceeds two hours the auto tune is aborted.
6. The controller then calculates the tuning parameters listed in Table 10-1 and resumes normal control action.

If you want 'Proportional only', 'PD', or 'PI' control, you should set the Integral time parameter or derivative time parameter to OFF before commencing the tuning cycle. These parameters are found in the Loop Setup (PID) pages, see Chapter 9. The tuner will leave them off and will not calculate a value for them.

Typical automatic tuning cycle



Calculation of the cutback values

Low cutback and *High cutback* are values that restrict the amount of overshoot, or undershoot, that occurs during large step changes in PV (for example, under start-up conditions).

If either low cutback, or high cutback, is set to 'Auto' the values are fixed at three times the proportional band, and are not changed during automatic tuning.

12.3.1 Carbon Potential Control

If the loop is configured for carbon potential control it is necessary to set the proportional band from 'Engineering Units' to 'Percentage' before initiating self tune. This is because the controller requires an error of at least one unit to be able to tune. In the case of carbon potential this signal is very often <1.

To set Proportional Band in Percentage:-

In LPxSET UP/Options Page

Scroll to 'Prop Bnd Units'

Press  or  button to select 'Percentage'

For further information see Chapter 9.

12.3.2 AutotuneParameters

Table Number: 10.3.2. These parameters allow you to autotune the loop		AUTOTUNE		
Parameter Name	Parameter Description	Value	Default	Access Level
Tune OL	Auto tune low power limit. Sets a minimum output limit during tuning	-100 to 100%	0	L1
Tune OH	Auto tune high power limit Sets a maximum output limit during tuning	-100 to 100%	0	L1
Autotune Loop	Selects the loop number to tune	LP1 LP1A LP1(CSD) Repeated for LP2 & LP3		L1
Autotune State	Shows the current state of autotune	Not Tuning Measuring Noise Tuning at SP Tuning to SP Finding Minimum Finding Maximum Storing Time End Calculating PID ABORTED	Not Tuning	L1 R/O
Tune OP	Tune output	-100 to 100		R/O L1
CSD Tune State	Cascade tuning state	Off Initialising Tuning Slave Waiting Waiting Again Tuning Master	Off	L1
Tune SP	The SP selected by the controller at which to tune	Display range		R/O L3
Stage Time	Time spent in an individual stage	0:00:00.0		R/O L3

12.3.3 How Tuning State is Displayed

The loop can only be tuned in operator level. When it is tuning the middle readout cycles between:-

- the parameter it is set up to display (normally SP)
- tune and
- the loop name, as follows:-

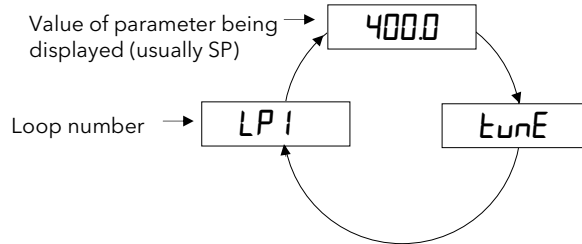


Figure 12-1: Display of Tuning State (Middle Display)

When the Loop View is selected the lower readout cycles between the power output bar graph and the current Tuning State message, as shown below:-

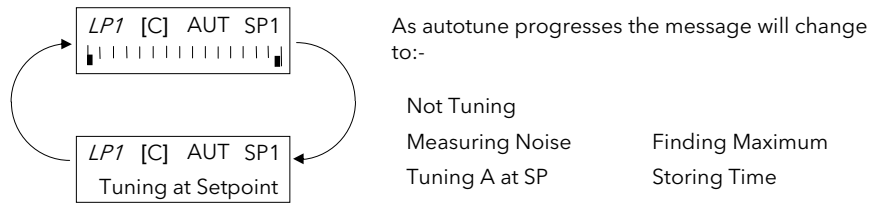

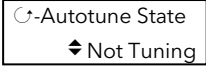


Figure 12-2: Display of Tuning State (Lower Display)

Its state is also displayed in the AUTOTUNE page as the parameter 'Autotune State'. To display this parameter:-

Do This	This Is The Display You Should See	Additional Notes
1. From the AUTOTUNE page header, press  until 'Autotune State' is displayed		This parameter displays the state of Autotuning. The choices are: Not Tuning Measuring Noise Tuning A at SP Tuning to SP Finding Minimum Finding Maximum Storing Time Calculating PID End ABORTED

MANUAL TUNING

If for any reason automatic tuning gives unsatisfactory results, you can tune the controller manually. There are a number of standard methods for manual tuning. The one described here is the Ziegler-Nichols method.

With the process at its normal running conditions:

1. Set the Integral Time and the Derivative Time to OFF.
2. Set High Cutback and Low Cutback to 'Auto'.
3. Ignore the fact that the PV may not settle precisely at the setpoint.
4. If the PV is stable, reduce the proportional band so that the PV just starts to oscillate. If PV is already oscillating, increase the proportional band until it just stops oscillating. Allow enough time between each adjustment for the loop to stabilise. Make a note of the proportional band value 'B' and the period of oscillation 'T'.
5. Set the proportional band, integral time and derivative time parameter values according to the calculations given in Table 10-2.

Type of control	Proportional band (P)	Integral time (I)	Derivative time (D)
Proportional only	2xB	OFF	OFF
P + I control	2.2xB	0.8xT	OFF
P + I + D control	1.7xB	0.5xT	0.12xT

Table 12-2: Tuning Values

Note:-

The parameters listed in the above table will be found under the heading **LPx SETUP** where x = 1, 2 or 3 and LPx can be a user defined name.

12.3.4 Setting the cutback values

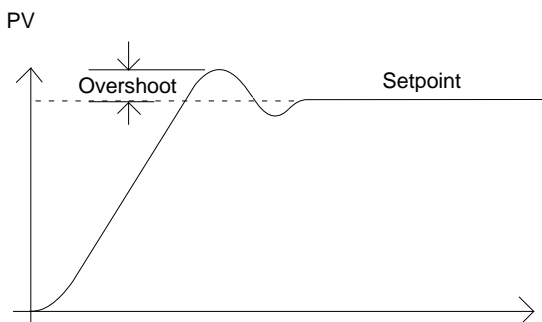
The above procedure sets up the parameters for optimum steady state control. If unacceptable levels of overshoot or undershoot occur during start-up, or for large step changes in PV, then manually set the cutback parameters.

Proceed as follows:

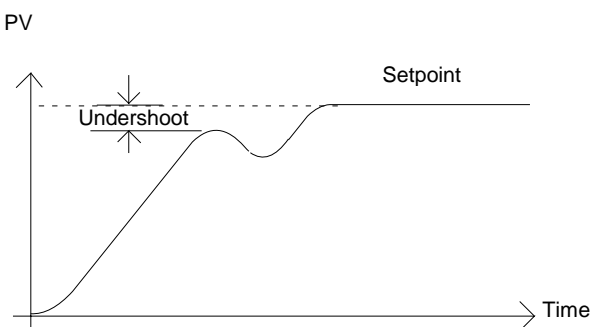
1. Set the low and high cutback values to three proportional bandwidths (that is to say, $Lcb = Hcb = 3 \times P$).
2. Note the level of overshoot, or undershoot, that occurs for large PV changes (see the diagrams below).

In example (a) increase Low Cutback by the overshoot value. In example (b) reduce Low Cutback by the undershoot value.

Example (a)



Example (b)



Where the PV approaches setpoint from above, you can set High Cutback in a similar manner.

12.3.5 Integral action and manual reset

In a full three-term controller (that is, a PID controller), the integral term automatically removes steady state errors from the setpoint. If the controller is set up to work in two-term mode (that is PD mode), the integral term will be set to 'OFF'. Under these conditions the measured value may not settle precisely at setpoint. The parameter 'Manual Reset' in the *Loop Setup* (PID) page is used to compensate for no integral term by providing a small output bleed, and must be set manually in order to remove the steady state error.

12.3.6 Valve Position Control

See section 9.7 'MOTORISED VALVE CONTROL', for an explanation of the additional parameters required for motorised valves and how to set the values of these parameters.

12.4 TUNING WHEN GAIN SCHEDULING IS USED

Gain scheduling is described in section 9.5. It is the automatic transfer of control between one set of control values and another set in non-linear control systems. Up to six sets can be configured and each set is configured to operate over a selected input range where the control operates over a reduced and approximately linear range.

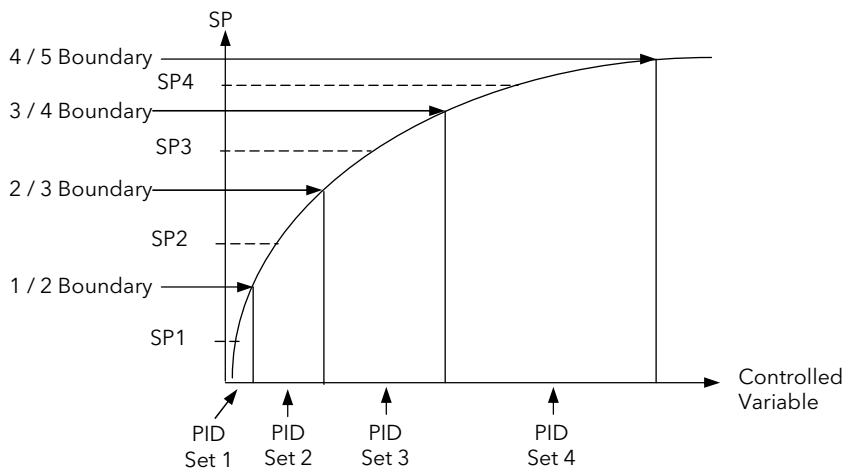


Figure 12-3: Gain Scheduling

12.4.1 Tuning Procedure

In normal operating mode 'Schedule type' will be set to PV, SP, OP, Error, Rem Sched IP or Soft Wired as dictated by the requirements of the process.

1. Select the number of PID sets required from 1 to 6.
2. Set the Boundaries over which each PID set is required to operate
3. Go to Configuration level (if not already selected)
4. Set 'Schedule Type' (*LPx-SETUP/PID* page) = 'Set'
5. Go to Level 3
6. Select 'Active PID Set' = 'PID Set 1'
7. Set the Setpoint to control at a point approximately midway between 0 and 1/2 Boundary
8. Select Autotune as described in section 10.3. At the end of tune the values will be automatically stored into PID Set 1. It is possible to limit the output power in each set.
9. Repeat the above for all PID sets. For each set, adjust the SP approximately midway between the two boundaries (Figure 10-1)
10. When all PID sets have been determined, go back to configuration level and re-set 'Schedule Type' to the type required for the process

Note: It is possible to tune each set when Gain Scheduling is selected, but this is not recommended since it is possible that, at the end of tune, the values could be stored into the incorrect PID set. This might occur, for example, if the system is highly oscillatory and the values for, say, PID set 2 are stored when the excursion is in PID set 1.

12.5 CASCADE TUNING

Cascade control uses a combination of two PID controllers, where the output of one (the master) provides the setpoint for the second (the slave). Cascade control was described in more detail in section 9.10. Figure 10.1 shows a cascade controller applied to the control of a furnace load.

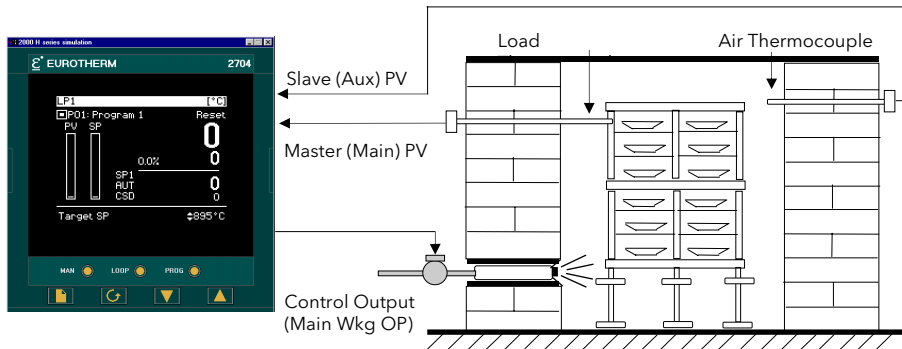


Figure 12-4: Cascade Control of a Furnace Load

When tuning a cascade loop it is necessary that both master and slave loops are tuned. It is recommended that each loop is tuned independently using the procedure below.

Because the slave loop is used by the master loop it must be tuned first.

12.5.1 To Tune a Full Scale Cascade Loop

Step 1. Configure the loop as cascade full scale as follows:-

In *LP1 SETUP/Options* Set 'Loop Type' = Cascade

In *LP1 SETUP/Cascade* Set 'Cascade Mode' = Full Scale
Set 'Disable CSD' = Yes

In *LP1 SETUP/SP* Set 'Setpoint 1' = the normal operating setpoint value for the main loop

In *LP1 SETUP/SP(Aux)* Set 'Local SP' = the normal operating setpoint value for the slave loop (when cascade is disabled)

Step 2. Start the controller in Level 3 as follows:

In *ACCESS* Select Level 3

Step 3. Set tune output high and low limits as follows:

Note: For the slave tune you may wish to restrict the ability of the tuner to disturb the process. Tune OH should, therefore, be set to a value that will only enable the tune to achieve the local setpoint which you have chosen.

In *AUTOTUNE* Set 'Tune OL' to a value which will limit the minimum output demand during tuning. This may be 0.0 for a heat only loop.

Set 'Tune OH' to a value which will limit the maximum output demand during tuning.

Step 4. Start tune on the slave loop as follows:

In *AUTOTUNE* Set 'Autotune Loop' to *LP1A*

Step 5. You may monitor the progress of the tune by viewing the following parameters:

In *AUTOTUNE* 'Autotune State' This indicates which step is being performed

'Tune OP' The output demand of the autotune. For a slave loop this will be the same as the working output power.

'Tune SP' The setpoint about which the loop is being tuned

'Stage Time' The length of time this particular step has been running. The tune step will abort after two hours

Step 6. On completion of the slave loop tuning:

Keep the loop in Cascade Disabled, and allow the slave loop to control the process. You must allow the slave loop to control at its Local SP. Wait for the master loop to settle to a steady state value. (Note, it is unlikely that the master loop steady state is the same as the slaves).

When the master PV is at a steady value proceed with tuning the master loop. (Note, if the master loop has not settled satisfactorily you may not be able to tune the master loop at all, since it is necessary to restrict the disturbance of the slave when tuning the master.

Step 7. Tune the master loop

In AUTOTUNE

Set 'Tune OL' and 'Tune OH'

The values chosen should be symmetrical and chosen such that the slave stays in control (typically ± 0.5 * slave proportional band).

This amount, however, may not be sufficient to disturb the master to achieve a successful tune. If the proportional band of the master is in engineering units, the tune hysteresis of the master will be ± 1 engineering unit. For a temperature loop, therefore, the master must be disturbed by at least 1 degree.

Tune OL and Tune OH are set in %. Although it is the master which is being tuned, it is the slave working SP which has to be modified in order to achieve a change in the output and hence measure a disturbance in the master PV. Therefore, Tune OL and Tune OH relate to a percentage of the slave range by which the slave working SP will be changed.

For example, if the slave has a range of -200 to +1372 the slave range is 1572 and Tune OL and Tune OH are 1%, then the slave working setpoint will be modified by ± 15.72 degrees.

In AUTOTUNE

Set 'Autotune Loop' to *LP1*

In LP1 SETUP/Cascade

Set 'Disable CSD' to 'No'

This is to re-enable cascade mode and must be done before the time out period of 1 min

Step 8: Return to control

The slave and master loops should now be tuned. Try changing the main setpoint and observe the response. If the master PV response is oscillatory then you may not have restricted the disturbance of the slave enough. Try decreasing the values of 'Tune OL' and 'Tune OH' and retune the master.

12.5.2 To Tune a Trim mode Cascade Loop

This example uses SP feedforward where the value of the MasterWSP is 50, the slave range is 0-200 and the Trim limits are 25%.

The slave setpoint calculation is shown in the diagram below which has been reproduced from the previous chapter.

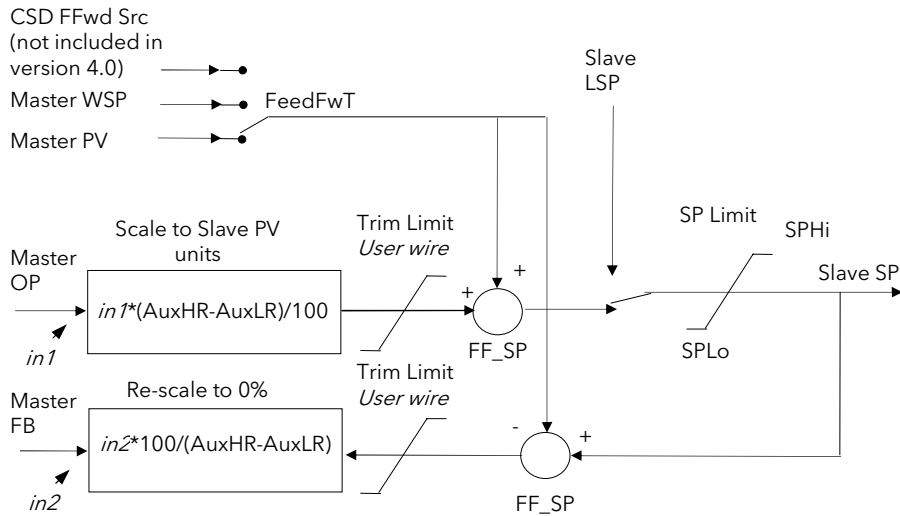


Figure 12-5: Cascade Controller in Trim Mode

The formula in the box "Scale to Slave PV units" simply normalises the masterOP to the slave range, for example, here a masterOP of 0% will produce a trim value of 0 units and an output of 100% a trim value of 200 units. A 50% master OP will produce 100. So if masterOP is 10% this will provide a trim value of 20 that will be added to the fed forward SP providing a working slave setpoint of 70.

It should also be noted if masterOP is 20% this should provide a trim value of 40, but because the trim limit is set a 25, instead of the slave setpoint going to 90 it will be limited to 75.

The feedback path via the parameter MasterFB ensures that the master loop will not go into integral saturation whilst the slave setpoint is being limited.

12.5.2.1 Tuning the Loop

Details of configuration

Master(LP1) loop range	= 0-100
Slave loop(LP1A) range	= 0-200
Cascade mode	= Trim SPFF(Setpoint feedforward)
CSDTrim lo	= -50(slave SP trim lo limit)
CSDTrim hi	= +50(slave SP trim hi limit)

Step 1. Tune slave

Disable cascade and tune the slave at a setpoint that you expect the slave to be operating at. In this case it is done at 70.

After tune is complete you must allow the slave to settle at its setpoint with no oscillations. This is very important.

Step 2 Tune Master

The master OP is normalised to the slave range. So in this configuration, if the master OP is 0%, the slave SP is also 0. If the master OP is 50% the SP is 100 and if the OP is 100% the setpoint is 200.

You need to inspect the value of the slave proportional band calculated by the slave autotune. In this case it was 36 (eng units).

To tune the master loop the autotune limits need to be set so that the slave SP is allowed to alter by half its proportional band. In this case, ± 18 units. To achieve this 'Tune OP low' is set to -9% and 'Tune OP high' to 9%. With a master SP of 70 this allows the slave to go to a high value of 88 and a low value of 52. Please note, during autotune the 9% is applied in addition to the Slave PV, not the slave setpoint when the master loop tune starts, therefore it is important that the slave has settled at its local SP.

After you have set the tune limits start the master(LP1) autotune and only after that enable cascade mode. When complete the controller can be operated in cascade mode.

Step 3 Normal Operation

Adjust the master SP to the required process value and observe control response.

13.CHAPTER 13 CONTROLLER APPLICATIONS

The 2604 controller contains control blocks specifically designed to suit a number of different applications.

Examples are:-

Carbon Potential, Oxygen or Dew Point control using Zirconia probes

Humidity control using wet and dry platinum resistance thermometers

About this chapter

This chapter gives general descriptions (which are not intended to be of a particular installation) of the use of the 2604 controller in the above applications.

- ◇ Brief description and terminology applications using zirconia probes
- ◇ An example wiring diagram for carbon potential control
- ◇ Viewing and adjusting the parameters for a carbon potential controller
- ◇ An example of soft wiring for a carbon potential control loop
- ◇ Brief description of humidity control
- ◇ An example wiring diagram for humidity control
- ◇ Viewing and adjusting the parameters for a humidity controller
- ◇ An example of soft wiring for a humidity control loop

13.1 ZIRCONIA - CARBON POTENTIAL CONTROL

A dual loop 2604 controller is required to control temperature of the process on one loop and carbon potential on the other. The controller is often a programmer which generates temperature and carbon potential profiles synchronised to a common timebase. In this section it is assumed that a programmer is used.

13.1.1 Temperature Control

The sensor input of the temperature loop may come from the zirconia probe but it is common for a separate thermocouple to be used. The controller provides a heating output which may be connected to gas burners or thyristors to control electrical heating elements. In some applications a cooling output may also be connected to a circulation fan or exhaust damper.

13.1.2 Carbon Potential Control

The zirconia probe generates a millivolt signal based on the ratio of oxygen concentrations on the reference side of the probe (outside the furnace) to the amount of oxygen in the furnace.

The controller uses the temperature and carbon potential signals to calculate the actual percentage of carbon in the furnace. This second loop generally has two outputs. One output is connected to a valve which controls the amount of an enrichment gas is supplied to the furnace. The second output controls the level of dilution air.

13.1.3 Sooting Alarm

In addition to other alarms which may be detected by the controller (see also Chapter 8 'Alarm Configuration'), the 2604 can trigger an alarm when the atmospheric conditions are such that carbon will be deposited as soot on all surfaces inside the furnace.

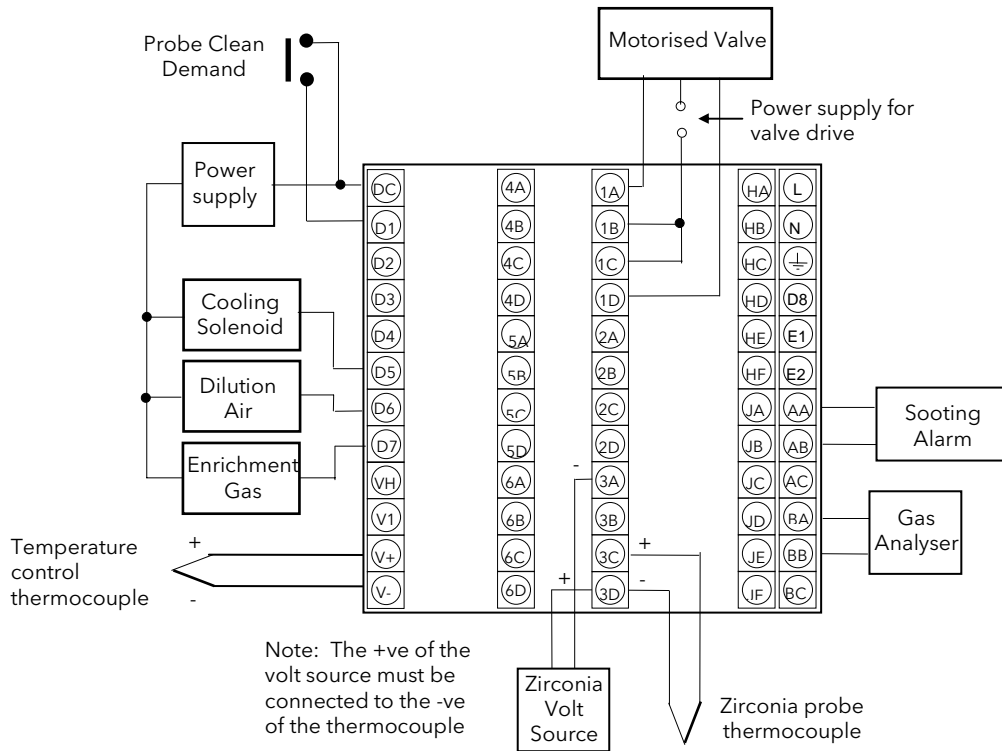
13.1.4 Automatic Probe Cleaning

The 2604 has a probe clean and recovery strategy that can be programmed to occur between batches or manually requested. A short blast of compressed air is used to remove any soot and other particles that may have accumulated on the probe. Once the cleaning has been completed the time taken for the probe to recover is measured. If the recovery time is too long this indicates that the probe is ageing and replacement or refurbishment is due. During the cleaning and recovery cycle, the %C reading is frozen thereby ensuring continuous furnace operation.

13.1.5 Endothermic Gas Correction

A gas analyser may be used to determine the CO concentration of the endothermic gas. If a 4-20mA output is available from the analyser, it can be fed into the 2604 to automatically adjust the calculated % carbon reading. Alternatively, this value can be entered manually.

13.1.6 Example of Carbon Potential Controller Connections



The above diagram is a generalised connection diagram, for further information refer to Appendix F 'Installation', and to the instructions supplied by the probe manufacturer.

In the above example the following modules are fitted. This will change from installation to installation:

- Module 1 Dual triac or relay to drive motorised valve
- Module 3 Dual PV Input Module
- Standard Digital I/O Used as logic input for manual probe clean and outputs for solenoid valve drives
- Standard PV Input For the temperature control thermocouple input
- Standard Analogue Input For gas analyser
- Standard Relay Output For sooting alarm

Figure 13-1: An Example of 2604 Wiring for Carbon Potential Control

13.2 TO VIEW AND ADJUST ZIRCONIA PARAMETERS

Do This	This Is The Display You Should See	Additional Notes
1. From any display press as many times as necessary to select 'ZIRCONIA PROBE' 2. Press to if necessary select 'Options Page'.		This page is only available if 'Zirconia' is Enabled in the INSTRUMENT (Options) page The page choices are:- Options Configure and adjust zirconia parameters. Wiring Soft wires zirconia parameters
3. Press as many times as necessary to scroll to the required parameter in the list 4. If the parameter is preceded by it is alterable. Press or to change its value		The first parameter is Zirconia Value. This is read only and is the value derived from the temperature and remote gas inputs The next parameter allows you to choose the type of probe which is to be used with the controller

13.2.1 Zirconia Parameters

Table Number: 11.2.1.		This table allows you to view or adjust zirconia probe parameters		ZIRCONIA PROBE (Options Page)	
Parameter Name	Parameter Description	Value	Default	Access Level	
Zirconia Value	Zirconia control process value The O2 or dew point value derived from temperature and remote gas ref inputs	Range units		R/O	
Probe Type	Zirconia probe equation	See note 1 for types supported		Conf	
Units	Zirconia display units	See Appendix D.2.		Conf	
Resolution	Zirconia display resolution	XXXXX to XX.XXX		Conf	
Oxygen Exp (Note 2)	Oxygen units Only available for 'Probe Type' = 'Log Oxygen'	0 to 19		Conf	
The following 10 parameters are not relevant to 'Probe Type' = 'Oxygen'					
H-CO Reference	Gas reference	0.0 to 999.0	20.0	L3	
Rem Gas Ref IP	Remote gas reference	0.0 to 999.0		L3	
Enable Rem H-CO	Remote gas enable. This can be an internal value from the user interface or remote from an external source.	Internal Remote	Internal	L3	
Working H-CO	Working gas reference or process factor	0.0 to 999.0		L3 R/O	
Process Factor	Process Factor is used in some zirconia probes to provide compensation for the varying abilities of different alloys to absorb carbon. Applies to MMI probes only	0.0 to 999.0		L3	
Clean Mode	Clean probe input	Off On	Off	L3	
Clean Freq	Zirconia probe cleaning interval	Off to 99:54:00.0	4:00:00:0	L3	
Clean Duration	Sets the cleaning time	0:00:06.0 to 1:39:54.0	0:10:00:0	L3	
Max Recvy Time	Maximum recovery time after purging	0:00:06.0 to 1:39:54.0	0:10:00:0	L3	
Min Recvy Time	Minimum recovery time after purging	0:00:06.0 to 1:39:54.0	0:10:00:0	L3	
Min Cal Temp	Minimum calculation temp.	-999.0		L3	
Probe Offset	Zirconia mV offset	to	0.0	L3	
Temp Offset	Sets the temperature offset for the probe	2000.0	0.0	L3	
The following 4 parameters are not relevant to 'Probe Type' = 'Oxygen'					
Next Clean	Time to next cleaning. (counts down to 0:00:00.0)	0:00:00.1		R/O L1	
Clean State	The burn off state of the zirconia probe	Inactive Cleaning Recovering		R/O L1	
Clean Output	Clean valve output	Off/On	Off	R/O L3	
Probe Status	Probe requires cleaning	Good/Bad		R/O L1	
Probe SBrk	Probe sensor break	No/Yes		R/O L1	
The following parameter is not relevant to 'Probe Type' = 'Oxygen'					
Sooting Alarm	Probe sooting alarm output	Good/Bad		R/O L1	
SootVal Scalar	Sooting value scalar	0.0 to 100.0	1.0	L3	
Probe IP	Zirconia probe mV input	-100 to 2000		R/O	
Temp IP	Zirconia probe temp input val	Temp range		R/O L3	
PV Invalid	PV Invalid	No/Yes		L3	
This is a boolean which is true when the temperature is below that set by 'Min Cal Temp'. It may have been wired in configuration mode, for example, to disable the gas valve.					

The following parameter is not relevant to 'Probe Type' = 'Oxygen'				
PV Frozen	PV Frozen	No/Yes		L3
This is a boolean which freezes the PV during a purging cycle. It may have been wired in configuration mode, for example, to disable control output during purging				

Note 1 Probe types supported: Probe mV, Bosch Carbon, Barber-Colman, MMI Carbon, MMI Dewpoint, AACC, Drayton, ACP, SSI, MacDhui, Oxygen, Log Oxygen, Bosch Oxygen, Dewpoint.

Note 2 To configure Oxygen in ppm, select 'Probe Type' = 'Oxygen' and 'Oxygen Exp' = '4'

13.2.2 Wiring Page

Table Number: 11.2.2.		These parameters configure zirconia probe block wiring.		ZIRCONIA PROBE (Wiring Page)	
Parameter Name	Parameter Description	Value	Default	Access Level	
mV Src	Zirconia probe mV input source	Modbus address		Conf	
Temp Src	Zirconia probe temperature input source	Modbus address		Conf	
Clean Src	Zirconia clean probe input source Not available for Oxygen Probe Types	Modbus address		Conf	
Rem Gas Src	Remote gas reference/Process factor source Not available for Oxygen Probe Types	Modbus address		Conf.	

13.3 ZIRCONIA WIRING EXAMPLE

13.3.1 The Zirconia Function Block

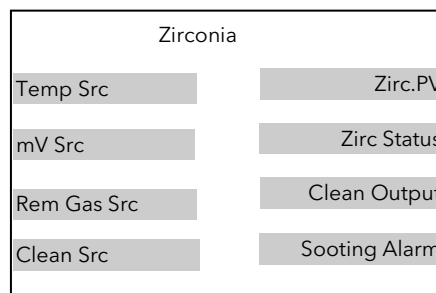


Figure 13-2: Zirconia Function Block

13.3.1.1 Main Features

Calculation of PV: The Process Variable can be carbon potential, Dewpoint or Oxygen concentration. The PV is derived from the probe temperature input, the probe mV input and remote gas reference input values. Various probe makes are supported.

Endothermic Gas Correction: This enables the user to set the percentage of carbon monoxide (%CO) present in the Endothermic Gas. This value can be measured via a gas analyser and fed into the controller as an analogue value.

Probe Clean: As these sensors are used in furnace environments they require regular cleaning. Cleaning (Burn Off) is performed by forcing compressed air through the probe. Cleaning can be initiated either manually or automatically using a timed period. During cleaning the PV output is frozen.

Health Alarm (Zirconia Probe Status): After cleaning an alarm output is generated if the PV does not return to 95% of its value within a specified time. This indicates that the probe is deteriorating and should be replaced.

Sooting Alarm: An output is generated which indicates that the furnace is about to soot.

13.3.2 Configuration of a Carbon Potential Control Loop

This example assumes that the probe temperature (Type K) input is connected to module 3 and the milli-volt input to module 6. Loop 1 normally controls temperature, so the carbon loop will be Loop 2. Carbon control and alarm outputs are relays and configured as On/Off.

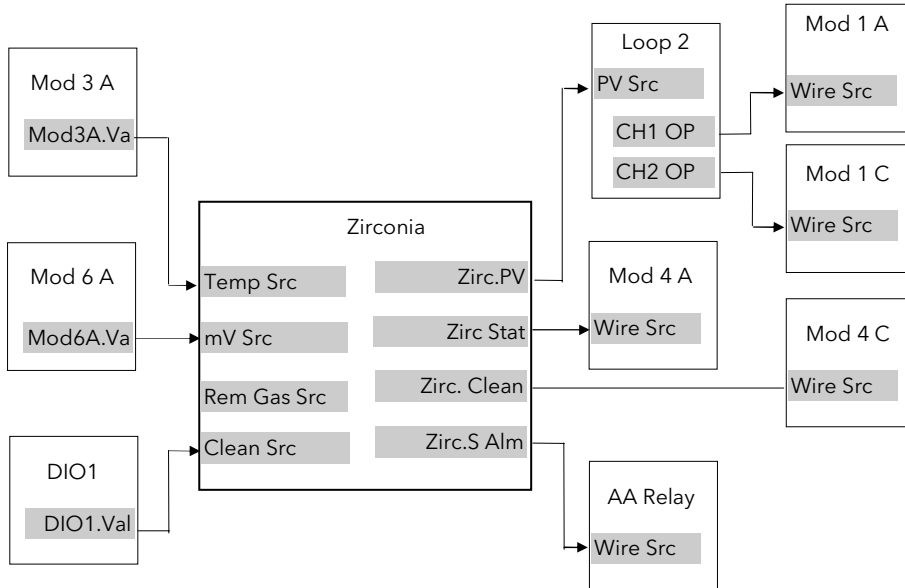


Figure 13-3: Zirconia Wiring for Carbon Potential

13.3.2.1 Implementation

1. In INSTRUMENT/Options Page
 - set 'Num of Loops' = 2
 - set 'Zirconia' = Enabled
2. In MODULE IO/Module 3A Page
 - set 'Channel Type' = Thermocouple
 - set 'Linearisation' = K-Type
 - set 'Units' = °C/°F/°K
 - set 'Resolution' = XXXXX
 - set 'SBrk Impedance' = Low
 - set 'SBrk Fallback' = Up Scale
 - set 'CJC Type' = Internal

This configures Module 3 to measure temperature.
3. In MODULE IO/Module 6A Page
 - set 'Channel Type' = HZVolts
 - set 'Linearisation' = Linear
 - set 'Units' = mV
 - set 'Resolution' = XXXXX
 - set 'SBrk Impedance' = Off
 - set 'SBrk Fallback' = Up Scale
 - set 'Electrical Lo' = 0.00
 - set 'Electrical Hi' = 2.00
 - set 'Eng Val Lo' = 0.00
 - set 'Eng Val Hi' = 2000

This configures Module 6 to measure probe mV.
4. In STANDARD IO/Dig IO1 Page
 - set 'Channel Type' = Digital Input

This configures DIO1 to be a digital input.
5. In ZIRCONIA PROBE/Options Page
 - set 'Probe Type' = *Type of probe in use*
 - set 'Units' = %CP
 - set 'Resolution' = XXX.XX

	set 'H-CO Reference' = <i>Required Value</i> <i>This value defines the % carbon monoxide (%CO) in the gas used for carburising</i>
	This configures the zirconia probe
6. In ZIRCONIA PROBE/Wiring Page	set 'Clean Src' = 05402:DI01.Val set 'mV Src' = 04948:Mod6A set 'Temp Src' = 04468:Mod3A This connects inputs to the Zirconia block
7. In LP2 SETUP/Options Page	set 'Loop Type' = Single set 'Control Type' = OnOff→Ch1&2
8. In LP2 SETUP/Wiring Page	set 'PV Src' = 11059:Zirc.PV This connects the PV to Loop 2 PV
9. In MODULE IO/Module 1A Page	set 'Channel Type' = On/Off set 'Wire Src' = 01037:L2.Ch1OP This connects LP2 Ch1 output to module 1
10. In MODULE IO/Module 1C Page	set 'Channel Type' = On/Off set 'Wire Src' = 01038:L2.Ch2OP This connects LP2 Ch2 output to module 1
11. In MODULE IO/Module 4A Page	set 'Channel Type' = On/Off set 'Wire Src' = 11066:Zirc.Stat This connects the health (probe status) to module 4A
12. In MODULE IO/Module 4C Page	set 'Channel Type' = On/Off set 'Wire Src' = 11067: Zirc.Clean This connects the clean outputs to module 4C
13. In STANDARD IO/AA Relay Page	set 'Channel Type' = On/Off set 'Wire Src' = 11068: Zirc.SAlm This connects the sooting alarm to the fixed relay output

See Appendix D for list of Modbus addresses.

© **Tip:- See 'Copy and Paste' description in Chapter 3.**

13.3.3 Probe Impedance

Probe impedance can be read by the parameter 'SBrk Trip Imp'. This parameter is found in the Standard IO or Module IO, PV or Analogue Inputs. It is, however, normal to use the Dual PV Input module for use with a Zirconia probe, so the 'SBrk Trip Imp' parameter will be found in MODULE IO/Module 3 or 6 page.

The units for this parameter is % and depends upon the setting of the 'SBrk Impedance' parameter found in the same page, as follows:-

If 'SBrk Impedance' = 'Low'	then a 'SBrk Trip Imp' reading of 100% is approximately 100KΩ
If 'SBrk Impedance' = 'High'	then a 'SBrk Trip Imp' reading of 100% is approximately 500KΩ

For a Zirconia probe the normal setting for 'SBrk Impedance' = 'High'

The wiring example in section 20.5.3. 'Zirconia Probe Impedance Measurement' shows how this may be implemented.

13.4 HUMIDITY CONTROL

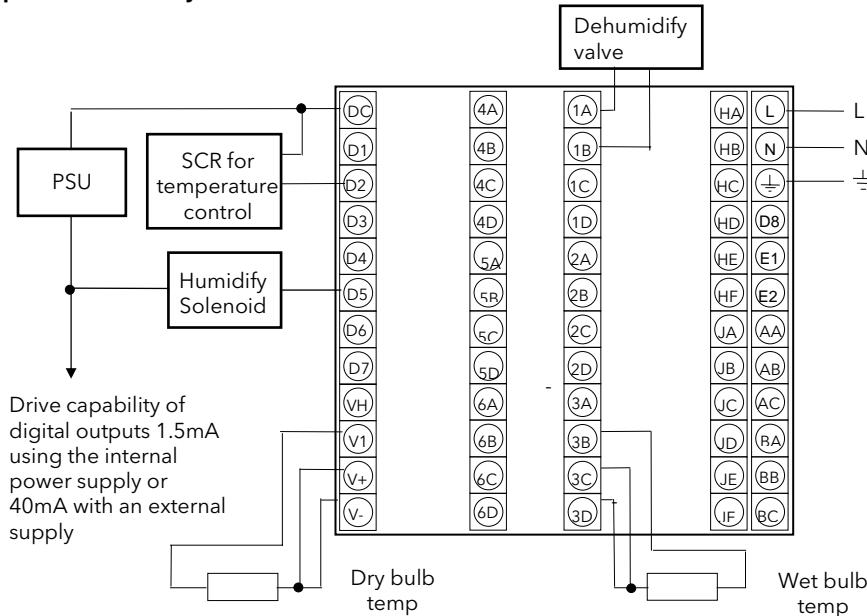
13.4.1 Overview

Humidity (and altitude) control is a standard feature of the 2604 controller. In these applications the controller may be configured to generate a setpoint profile (see Chapter 6 'Programmer Configuration').

The controller may be configured to measure humidity using either the traditional Wet/Dry bulb method (figure 11.4) or it may be interfaced to a solid state sensor.

The controller output may be configured to turn a refrigeration compressor on and off, operate a bypass valve, and possibly operate two stages of heating and/or cooling

13.4.2 Example Of Humidity Controller Connections



In the above example the following modules are fitted. This will change from installation to installation:

- Module 1 Analogue or relay to drive dehumidify valve
- Module 3 PV input module for wet bulb temperature RTD
- Standard Digital I/O Used as logic outputs for humidify solenoid valve and temperature control SCR
- Standard PV Input For the dry bulb RTD used for the temperature control and humidity calculation

Figure 13-4: Example of Humidity Controller Connections

13.4.3 Temperature Control Of An Environmental Chamber

The temperature of an environmental chamber is controlled as a single loop with two control outputs. The heating output time proportions electric heaters, usually via a solid state relay. The cooling output operates a refrigerant valve which introduces cooling into the chamber. The controller automatically calculates when heating or cooling is required.

13.4.4 Humidity Control Of An Environmental Chamber

Humidity in a chamber is controlled by adding or removing water vapour. Like the temperature control loop two control outputs are required, i.e. Humidify and Dehumidify.

To humidify the chamber water vapour may be added by a boiler, an evaporating pan or by direct injection of atomised water.



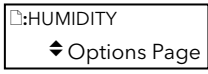




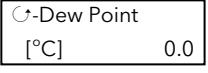
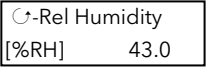
If a boiler is being used adding steam increases the humidity level. The humidify output from the controller regulates the amount of steam from the boiler that is allowed into the chamber.

An evaporating pan is a pan of water warmed by a heater. The humidify output from the controller humidity regulates the temperature of the water.

An atomisation system uses compressed air to spray water vapour directly into the chamber. The humidify output of the controller turns on or off a solenoid valve.

Dehumidification may be accomplished by using the same compressor used for cooling the chamber. The dehumidify output from the controller may control a separate control valve connected to a set of heat exchanger coils.

13.5 TO VIEW AND ADJUST HUMIDITY PARAMETERS

Do This	This Is The Display You Should See	Additional Notes
1. From any display press  as many times as necessary to select 'HUMIDITY' 2. Press  to if necessary select 'Options Page'.		This page is only available if 'Humidity' is Enabled in the INSTRUMENT (Options) page. Page choices are:- Options Configure and adjust humidity parameters. Wiring Soft wires humidity parameters
3. Press  as many times as necessary to scroll to the required parameter in the list 4. If the parameter is preceded by  it is alterable. Press  or  to change its value		The first parameter is read only and indicates the measured value of dew point
		The next parameter is also read only and is the measurement of relative humidity

The full list of parameters available under these list headers is shown in the following tables. They are selected and altered as described above



13.5.1 Humidity Options Parameters

Table Number: 11.5.1. These parameters allow you to view or adjust the parameters for humidity control		HUMIDITY		
Parameter Name	Parameter Description	Value	Default	Access Level
Dew Point	Wet/Dry temperature measurement of dew point	-999.9 to 999.9		L1 R/O
Rel Humidity	Relative Humidity	0.0 to 100.0		L1 R/O
Resolution	Display resolution	XXXXX XXXX.X XXX.XX XX.XXX X.XXXX		L3
Atm Pressure	Atmospheric Pressure	0.0 to 2000.0	1013 mbar	L3
PMetric Const	Psychrometric Constant	0.0 to 10.0	6.66	L3
Wet Bulb Offs	Wet bulb temperature correction	-100.0 to 100.0	0.0	L3
Humidity SBrk	Sensor break action for humidity control	No Yes		L1 R/O
Dry Bulb Temp	Dry Bulb Temperature	Range units		L1 R/O
Wet Bulb Temp	Wet Bulb Temperature	Range units		L1 R/O

13.5.2 Wiring Page

Table Number: 11.5.2. These parameters configure humidity block wiring.		HUMIDITY (Wiring Page)		
Parameter Name	Parameter Description	Value	Default	Access Level
Dry Bulb Src	Dry bulb temperature source	Modbus address.		Conf
Wet Bulb Src	Wet bulb temperature source			Conf
Atm Press Src	Atmospheric pressure source			Conf
PMetric Cst Src	Psychrometric Constant source		6.66	Conf

13.6 HUMIDITY WIRING EXAMPLE

13.6.1 The Humidity Function Block

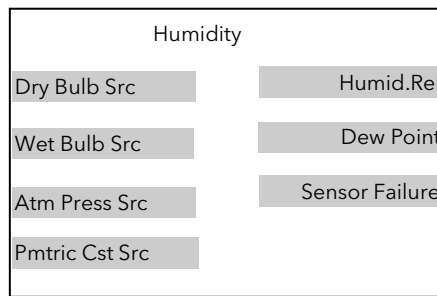


Figure 13-5: Humidity Function Block

13.6.1.1 Main Features

Calculation of PV: The Process Variable can be Relative Humidity or Dewpoint. The PV is derived from the wet and dry bulb inputs and atmospheric pressure.

Pressure Compensation: This value can be measured via a transmitter and fed into the controller as an analogue value. Alternatively, it can be set as a fixed parameter.

13.6.2 Configuration of a Humidity Control Loop

This example assumes that the dry temperature (Pt100) input is connected to the main PV and the wet input (Pt100) to module 3. Loop 1 normally controls temperature, so the humidity loop will be Loop 2. Humidity control outputs are relays and configured as time proportioning.

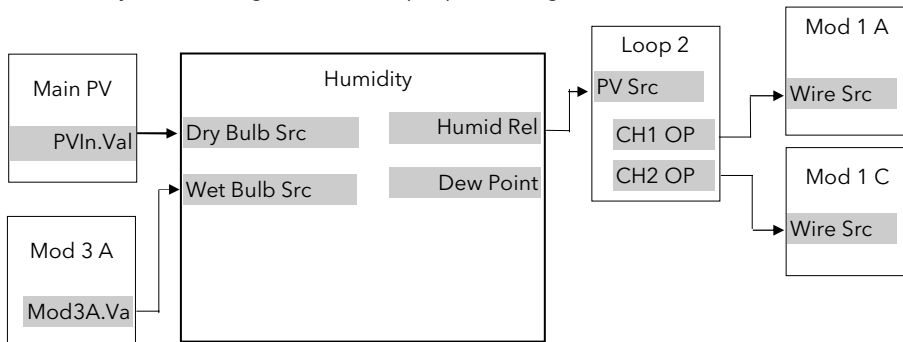


Figure 13-6: Humidity Control Loop

13.6.2.1 Implementation

1. In INSTRUMENT/Options Page
 - set 'Num of Loops' = 2
 - set 'Humidity' = Enabled
2. In STANDARD IO/PV Input Page
 - set 'Channel Type' = RTD
 - set 'Linearisation' = PT100
 - set 'Units' = °C/°F/°K
 - set 'Resolution' = XXXX.X
 - set 'SBrk Impedance' = Low
 - set 'SBrk Fallback' = Up Scale
 - This configures the PV Input to measure dry temperature
3. In MODULE IO/Module 3A Page
 - set 'Channel Type' = RTD
 - set 'Linearisation' = PT100
 - set 'Units' = °C/°F/°K
 - set 'Resolution' = XXXX.X
 - set 'SBrk Impedance' = Off
 - set 'SBrk Fallback' = Up Scale
 - This configures Module 3 to measure wet temperature
4. In HUMIDITY/Options Page
 - set 'Atm Pressure' = 1013.0 (for sea level)
5. In HUMIDITY/Wiring Page
 - set 'Dry Bulb Src = 05108:PVIn.Val
 - set 'Wet Bulb Src = 04468:Mod3A.Val
 - This connects the sensors to the humidity block
6. In LP2 SETUP/Options Page
 - set 'Control Type' = PID→Ch1 PID→Ch2
7. In LP2 SETUP/Wiring Page
 - set 'PV Src' = 11105:Humid.Rel
 - Note: For Dewpoint select 11106
 - This connects the %RH output to Loop 2 PV
8. In LP2 SETUP/Output Page
 - set 'OP Low Limit' = -100.0
 - set 'OP High Limit' = 100.0
9. In MODULE IO/Module 1A Page
 - set 'Channel Type' = Time Proportion
 - set 'Wire Src' = 01037:L2.Ch1OP
 - This connects LP2Ch1 output to Module 1A
10. In MODULE IO/Module 1C Page
 - set 'Channel Type' = Time Proportion
 - set 'Wire Src' = 01038:L2.Ch2OP
 - This connects L21Ch2 output to Module 1C

See Appendix D for list of Modbus addresses.

© **Tip:- See 'Copy and Paste' description in Chapter 3.**

14.CHAPTER 12 INPUT OPERATORS

14.1 WHAT ARE INPUT OPERATORS

The 2604 controller can have three control loops. Each loop can be independently configured to the process to be controlled. This has been described in Chapters 10 and 11 for PID, Cascade, Ratio, Override, Humidity Control, etc. It is also possible to apply custom linearisation to the inputs of each loop. This is a 16 point straight line linearisation and the parameters can be made available at Levels 1, 2 and 3 so that scaling can be carried out during commissioning. There are three Custom linearisation pages.

Also included in this section are parameters which allow you to switch inputs between different measuring transducers when the process is required to operate over a range which is too great for a single transducer. A typical application may be to switch between a thermocouple and pyrometer or between two different thermocouple types in a high temperature furnace.

The page headers are:

INPUT OPERS ▶	Cust Lin 1 Page	These parameters set up the custom linearisation for input 1
	Cust Lin 2 Page	These parameters set up the custom linearisation for input 2
	Cust Lin 3 Page	These parameters set up the custom linearisation for input 3
	Switch 1 Page	These parameters provide switch over between thermocouple types or pyrometer
	Monitor 1 Page	Logs maximum and minimum, counts time above threshold
	BCD Input Page	Monitors the Digital Inputs when configured for BCD switch

The Input Operators page is only available if Input Operators has been enabled in configuration level.

Note:

In addition to linearising the controller inputs channels, it is equally valid to customise other sources such as Output Channels. This allows you, for example, to compensate for non linear control valve characteristics.

14.2 CUSTOM LINEARISATION

The linearisation uses a 16 point straight line fit.

Figure 12.1 shows an example of a curve to be linearised and is used to illustrate the terminology used for the parameters found in the **INPUT OPERS (Cust Lin 7 Page)**.

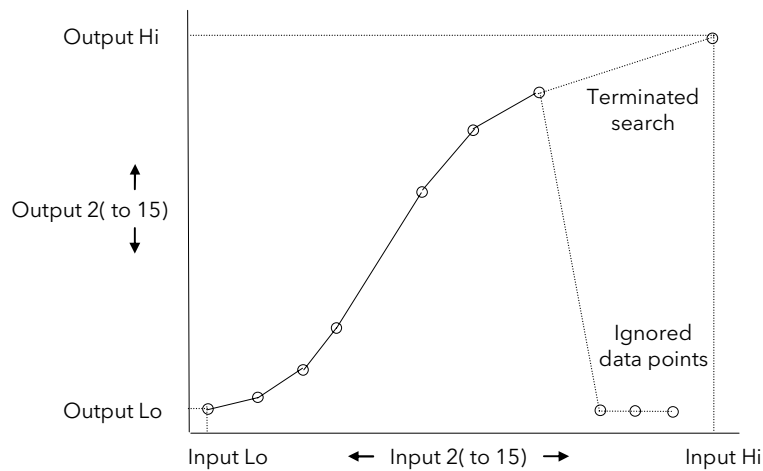


Figure 14-1: Linearisation Example

Notes:

1. The linearisation block works on rising inputs/rising outputs or rising inputs/falling outputs. It is not suitable for outputs which rise and fall on the same curve.
2. Input Lo/Output Lo and Input Hi/Output Hi are entered first to define the low and high points of the curve. It is not necessary to define all 15 intermediate points if the accuracy is not required. Points not defined will be ignored and a straight line fit will apply between the last point defined and the Input Hi/Output Hi point.

14.2.1 Compensation for Sensor Non-Linearities

The custom linearisation feature can also be used to compensate for errors in the sensor or measurement system. The intermediate points are, therefore, available in Level 1 so that known discontinuities in the curve can be calibrated out. Figure 12.2 shows an example of the type of discontinuity which can occur in the linearisation of a temperature sensor.

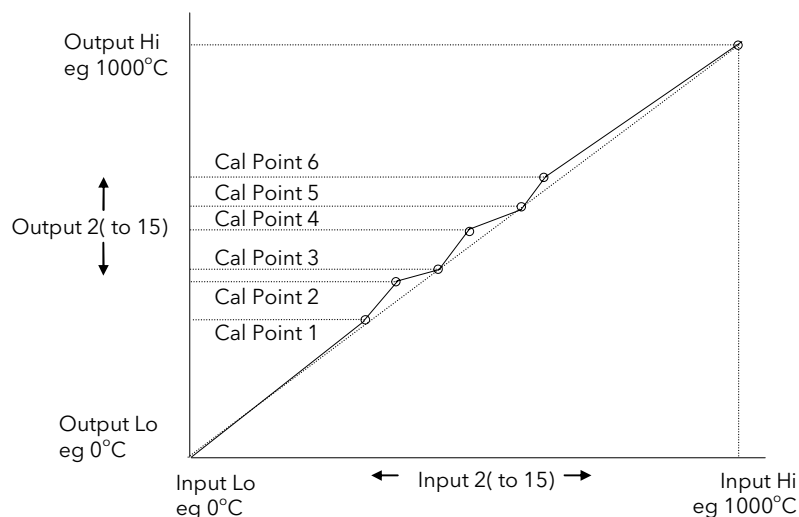







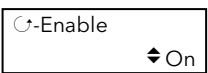



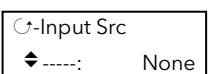




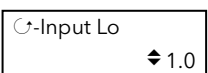



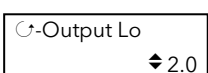


Figure 14-2: Compensation for Sensor Discontinuities

The calibration of the sensor uses the same procedure as described above. Adjust the output (displayed) value against the corresponding input value to compensate for any errors in the standard linearisation of the sensor.

14.2.2 To Create a Linearised Input

Do This	This Is The Display You Should See	Additional Notes
1. From any display press  as many times as necessary to select 'INPUT OPERS' 2. Press  or  to choose a Custom Linearisation page		This page is only available if 'Input Opers' is Enabled in the INSTRUMENT (Options) page. Three Custom Linearisation pages are available. Each can be soft wired to operate on a particular physical input. See section 12.7 for an example
3. Press  to show the first parameter 'Enable' 4. Press  or  to 'On'		
5. Press  to 'Input Src' 6. Press  or  to choose the modbus address of the input source		This parameter allows you to soft wire the custom linearisation block to an input source using the modbus address of that source. The address can be chosen by its numerical value or press  again to choose it by its mnemonic (Appendix D)
7. Press  as many times as necessary to scroll to 'Input Lo' 8. Press  or  to adjust the value		Intermediate parameters are shown in the following table. Input Lo is shown in Figure 12-1 and defines the lowest point which you wish to set
9. Press  as many times as necessary to scroll to 'Output Lo' 10. Press  or  to adjust the value		'Output Lo' is the output value from the block corresponding to 'Input Lo'. The resolution of this parameter is set by the parameter 'Output Resol'

Now set up the high calibration point followed by up to 15 intermediate points.



The full list of parameters is shown in the following table

14.2.3 Input Operators Custom Linearisation Parameters

Table Number: 12.2.3.		This page allows you to set up a customised linearisation curve		INPUT OPERS (Cust Lin 1)	
Parameter Name	Parameter Description	Value	Default	Access Level	
Enable	To enable custom linearisation	Off On	Off	L3	
Input Src	Custom linearisation input source	Modbus address		Conf	
Output Units	Custom linearisation output units	See Appendix D.2.		Conf	
Output Resol	Custom linearisation output resolution	XXXXX XXXX.X XXX.XX XX.XXX X.XXXX		Conf	
Input Value	The current value of the input	Range		R/O L1	
Output Value	The current value of the output	Range		R/O L1	
Output Status	The conditions are OK The conditions are bad or out of range	Good Bad		R/O L1	
Input Lo	Adjust to the low input value	Range		L3	
Output Lo	Adjust to correspond to the low input value	Range		L3	
Input Hi	Adjust to the high input value	Range		L3	
Output Hi	Adjust to correspond to the high input value	Range		L3	
Input 2	Adjust to the first break point	Range		L1	
Output 2	Adjust to correspond to input 2	Range		L1	
The above two parameters are repeated for all intermediate break points, ie 3 to 14					
Input 15	Adjust to the last break point	Range		L1	
Output 15	Adjust to correspond to input 15	Range		L1	

The above table is repeated for:

- INPUT OPERS (Cust Lin 2 Page)
- INPUT OPERS (Cust Lin 3 Page)

14.3 THERMOCOUPLE/PYROMETER SWITCHING

This facility is commonly used in wide range temperature applications where it is necessary to control accurately over the range. A thermocouple may be used to control at lower temperatures and a pyrometer then controls at very high temperatures. Alternatively two thermocouples of different types may be used.

Figure 12-3 shows a process heating over time with boundaries which define the switching points between the two devices. The higher boundary (Switch Hi) is normally set towards the top end of the thermocouple range and the lower boundary (Switch Lo) set towards the lower end of the pyrometer (or second thermocouple) range. The controller calculates a smooth transition between the two devices.

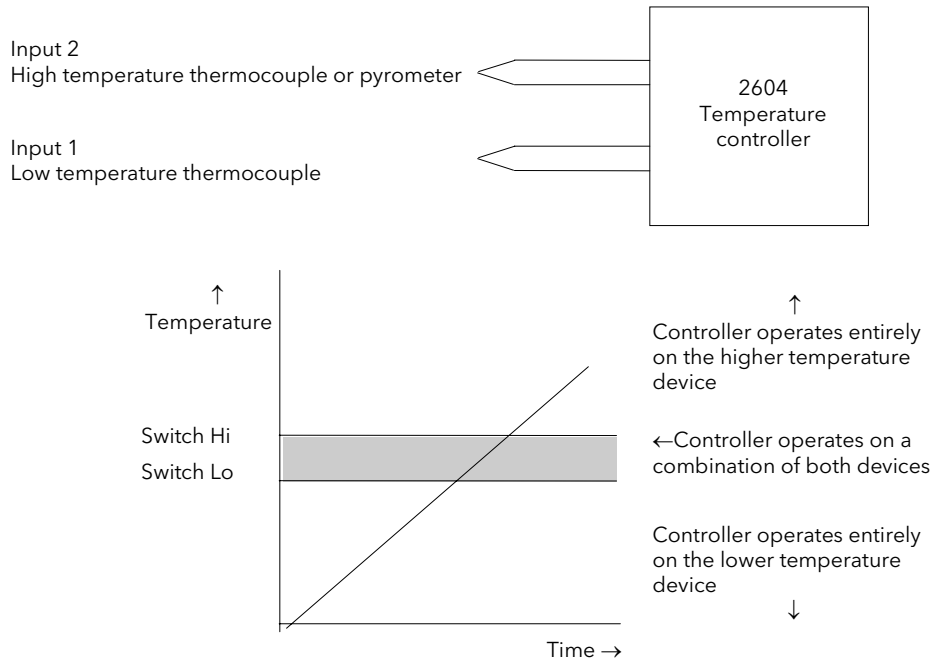


Figure 14-3: Thermocouple to Pyrometer Switching

14.3.1 To Set Up Thermocouple/Pyrometer Switching Points

Do This	This Is The Display You Should See	Additional Notes
1. From any display press as many times as necessary to select 'INPUT OPERS'		This page is only available if 'Input Opers' is Enabled in the INSTRUMENT (Options) page. One 'Switch' page is available
2. Press or to choose 'Switch 1 Page'		
3. Press to the first parameter 'Enable'		
4. Press or to 'Enabled'		
5. Press to 'Input 1 Src'		This parameter allows you to soft wire input 1 to an input source using the modbus address of that source. The address can be chosen by its numerical value or press again to choose it by its mnemonic (Appendix D) Repeat for Input 2
6. Press or to choose the modbus address of the input source		
7. Press as many times as necessary to scroll to 'Switch Lo'		Intermediate parameters are shown in the following table. Switch Lo is shown in Figure 12-3 and defines the point at which the thermocouple begins to transfer to the pyrometer
8. Press or to adjust the value		
9. Press as many times as necessary to scroll to 'Switch Hi'		Switch Hi is shown in Figure 12-3 and defines the point at which the pyrometer only is measuring the process Note 'Switch Lo' and 'Switch Hi' can only be adjusted within the limits set by 'Input Lo' and 'Input Hi'.
10. Press or to adjust the value		

The full list of parameters is shown in the following table. They can be set using the above procedure.

14.3.2 Input Operators Switch Over Parameters

Table Number: 12.3.2. This page allows you to set up and inspect Switch Over parameters		INPUT OPERS (Switch 1 Page)		
Parameter Name	Parameter Description	Value	Default	Access Level
Enable	To enable switch over	Disabled / Enabled	Off	Conf
Active Input	Indicates the input currently selected	Input 1 / Input 2 / Both Inputs		R/O L3
Input 1 Src	Input 1 source	Modbus address		Conf
Input 2 Src	Input 2 source			Conf
Input Lo	Display low limit	Display range		Conf
Input Hi	Display High limit	Display range		Conf
Switch Lo	PV = Input 1 below this value	Display Range		L3
Switch Hi	PV = Input 2 above this value	Display Range		L3
Switch Lo and Hi can be adjusted up to the limit set by 'Input Hi' and 'Input Lo' in configuration level				
Output Value	The current working value	Display Range		R/O L1
Output Status	The conditions are OK or out of range	Good / Bad		R/O L1
Input 1 Value	The current working value (can only be adjusted if Input 1 not wired)	Display Range		R/O L1
Input 1 Status	The conditions are correct or out of range	Good / Bad		R/O L1
Input 2 Value	The current working value (can only be adjusted if Input 2 not wired)	Display Range		R/O L1
Input 2 Status	The conditions are correct or out of range	Good / Bad		R/O L1

14.4 THE MONITOR BLOCK

The Monitor block:

1. Logs the Maximum and Minimum excursions of the PV. These values are reset when:-
 - a) An external logic input, configured as reset, is enabled
 - b) The 'Reset' parameter, see Table 12.4.1, is changed to Yes
2. Counts the time above a threshold
3. Provides a time alarm

14.4.1 Input Operators Monitor Parameters

Table Number: 12.4.1.		This page allows you to set up Monitor parameters.		INPUT OPERS (Monitor 1 Page)	
Parameter Name	Parameter Description	Value	Default	Access Level	
Enable	Monitor enable	Disabled Enabled	Off	Conf	
Input Src	Input source	Modbus addr		Conf	
Reset Src	Reset source	Modbus addr		Conf	
Input	Input value	Range		L1	
Reset	Reset	No = to run Yes = to reset	No	L3	
Maximum	Reads the maximum value recorded by the controller between resets, see 1. above	Range		R/O L1	
Minimum	Reads the minimum value recorded by the controller between resets, see 1. above	Range		R/O L1	
Trigger	PV threshold for timer log	Range		L3	
Day	Reads days above threshold	0 to 32767		R/O L1	
Time	Reads time above threshold	0:00:00.0		R/O L1	
Day Alarm	This sets the alarm threshold for the number of days that the alarm is active	0 to 32767		L3	
Time Alarm	This sets the alarm threshold for the time that the alarm is active	0:00:00.0		L3	
Alarm Output	Displays an alarm when the number of days or time has been exceeded	Off On		R/O L1	

14.5 BCD INPUT

An available option with the 2604 is the Binary Coded Decimal (BCD) function block. This feature is normally used to select a program number by using panel mounted BCD decade switches. A configuration example for this block is given in Section 12.7.2.

14.5.1 Main Features

Calculation of BCD Value: The function calculates a BCD value dependant upon the state of the inputs. Unconnected inputs are detected as off. This value is available as a wireable parameter.

Calculation of Decimal Value: The function calculates a decimal value dependant upon the state of the inputs. Unconnected inputs are detected as off. This value is available as a wireable parameter.

Digit 1 Output: The function calculates the first decade BCD value dependant on the state of inputs 1 to 4. Unconnected inputs are detected as off. This value is available as a wireable parameter.

Digit 2 Output: The function calculates the second decade BCD value dependant on the state of inputs 5 to 8. Unconnected inputs are detected as off. This value is available as a wireable parameter.

2 nd Decade	1 st Decade	BCD	Decimal	2 nd Digit	1 st Digit
0011	1001	39	57	3	9
0010	0110	26	38	2	6

14.5.2 BCD Parameters

Table Number: 12.5.2. This page allows you to configure the BCD input values		INPUT OPERS (BCD Input Page)		
Parameter Name	Parameter Description	Value	Default	Access Level
Enable	BCD enable	Off On	Off	Conf
IP1 Src-LSB	Input 1 source (LSB)	Modbus address		Conf
IP2 Src	Input 2 source	Modbus address		Conf
IP3 Src	Input 3 source	Modbus address		Conf
IP4 Src	Input 4 source	Modbus address		Conf
IP5 Src	Input 5 source	Modbus address		Conf
IP6 Src	Input 6 source	Modbus address		Conf
IP7 Src	Input 7 source	Modbus address		Conf
IP8 Src-MSB	Input 8 source (MSB)	Modbus address		Conf
BCD Value	Reads the value (in BCD) of the switch as it appears on the digital inputs	0-99		R/O L1
Decimal Value	Reads the value(in decimal) of the switch as it appears on the digital inputs	0-255		R/O L1
Digit 1(units)	Units value of the first switch	0-9		R/O L1
Digit 2(Tens)	Tens value of the second switch	0-9		R/O L1

14.6 INPUT OPERATORS WIRING EXAMPLES

14.6.1 Switch Over Loop With Custom Linearised Input

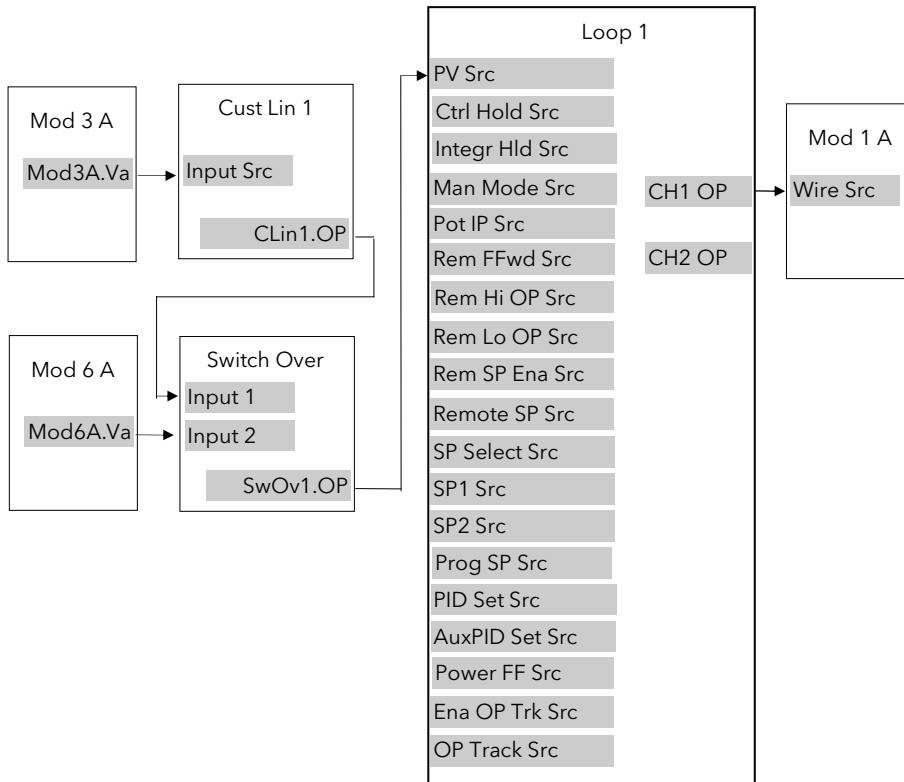


Figure 14-4: Example Wiring, Switch Over Loop with Custom Linearised Input

14.6.1.1 Implementation

1. In INPUT OPERS/Custom Lin 1
 - set 'Input Src' = 04468:Mod3A.Val (Appendix D)
 - This connects the input of the custom linearisation block to the output of Module 3A fitted as a PV input module.
2. In INPUT OPERS/Switch 1 Page
 - set 'Input 1 Src' = 03365:CLin1.OP (Appendix D)
 - This connects input 1 of the switch over block to the output of custom linearisation block 1.
3. In INPUT OPERS/Switch 1 Page
 - set 'Input 2 Src' = 04948:Mod6A.Val (Appendix D)
 - This connects input 2 of the switch over block to the output of module 6A fitted as an analogue input module.
4. In LOOP SETUP/Wiring Page
 - Set 'PV Src' = 03477:SwOv1.OP (Appendix D)
 - This connects the PV input of Loop 1 to the output of the switch over block.
5. In MODULE IO/Module 1A Page
 - Set 'Wire Src' = 00004:L1.Wkg OP (Appendix D)
 - This connects the input of module 1A to channel 1 output of loop 1. This module may be fitted as an analogue, relay, triac or logic output.

See Appendix D for list of Modbus addresses.

© Tip:- See 'Copy and Paste' description in Chapter 3.

14.6.2 Configuring the BCD Input to Select a Program

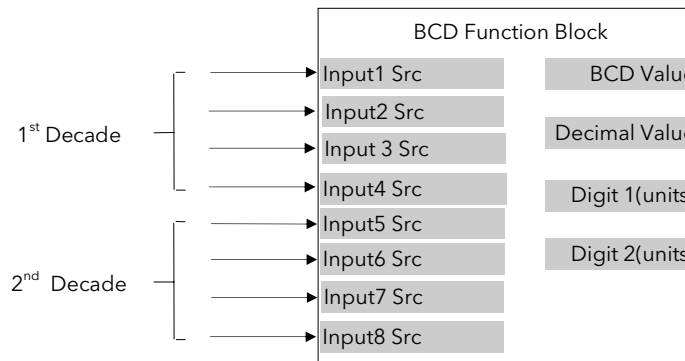


Figure 14-5: BCD Function Block

This example assumes that the digital inputs are connected to the standard IO.

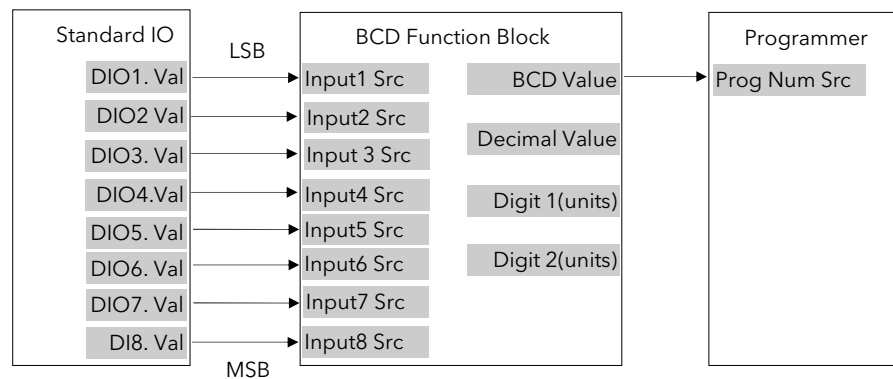


Figure 14-6: Wiring of Digital Inputs to the BCD Function Block

14.6.2.1 Implementation

1. In PROGRAM EDIT/Options Page set 'BCD Prg Num' = Yes
2. In STANDARD IO/DIO1 Page set 'Channel Type' = Digital Input
3. In STANDARD IO/DIO2 Page set 'Channel Type' = Digital Input
4. In STANDARD IO/DIO3 Page set 'Channel Type' = Digital Input
5. In STANDARD IO/DIO4 Page set 'Channel Type' = Digital Input
6. In STANDARD IO/DIO5 Page set 'Channel Type' = Digital Input
7. In STANDARD IO/DIO6 Page set 'Channel Type' = Digital Input
8. In STANDARD IO/DIO7 Page set 'Channel Type' = Digital Input
9. In INPUT OPERS/BCD Input Page set 'Enable' = On
10. In INPUT OPERS/BCD Input Page Set 'Input1 Src' = 05402:DIO1.Val
11. In INPUT OPERS/BCD Input Page Set 'Input2 Src' = 05450:DIO2.Val
12. In INPUT OPERS/BCD Input Page Set 'Input3 Src' = 05498:DIO3.Val
13. In INPUT OPERS/BCD Input Page Set 'Input4 Src' = 05546:DIO4.Val
14. In INPUT OPERS/BCD Input Page Set 'Input5 Src' = 05594:DIO5.Val
15. In INPUT OPERS/BCD Input Page Set 'Input6 Src' = 05642:DIO6.Val
16. In INPUT OPERS/BCD Input Page Set 'Input7 Src' = 05690:DIO7.Val
17. In INPUT OPERS/BCD Input Page Set 'Input8 Src' = 11313:DIO8.Val
18. In PROGRAM EDIT/Wiring Page Set 'Prog Num Src' = 10450

This connects the output of the BCD block to the program number.

14.6.3 Holdback Duration Timer

This procedure describes how to configure a 2604 controller, using the Monitor Block, to accumulate the total time that a program has been in holdback within a segment. A holdback timer can be used to inform the user his application is taking longer to heat up than normal, possibly indicating a problem with the heat source or unusually high losses.

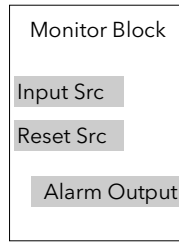


Figure 14-7: Monitor Function Block

The Monitor Block functions are as follows:

1. Logs the maximum and minimum excursions of its input value. These values are reset when:
 - a) the controller power is cycled
 - b) the block is reset
2. Counts the time above a threshold
3. Provides a time alarm

This example assumes that the controller has already been set up as a single loop programmer, and that program digital output 1 is used to enable the timer during certain segments. This is used to reset the monitor at the end of the segment. The maximum expected holdback time is set to 30 minutes. When this time is exceeded the AA relay is switched on.

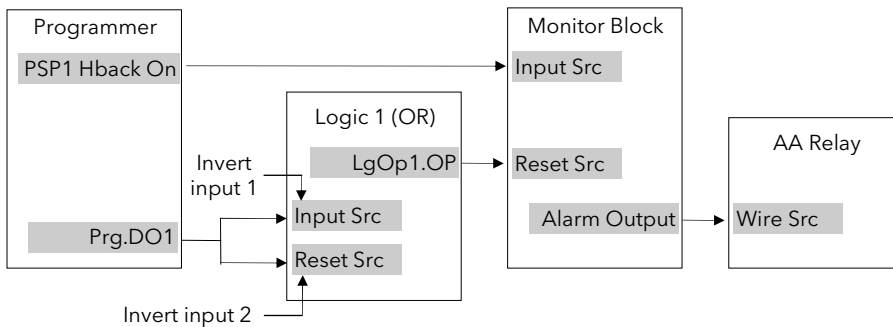


Figure 14-8: Example Wiring, Holdback Duration Timer

14.6.3.1 Implementation

1. In LOGIC OPERATORS/Logic 1 Page
 - set 'Operation' = OR
 - set 'Input 1 Src' = 05869:Prg.DO1
 - set 'Input 2 Src' = 05869:Prg.DO1
 - set 'Invert' = Invert Both
 - This inverts the sense of Program DO1
2. In INPUT OPERS/Monitor 1 Page
 - Set 'Enable' = Enabled
 - Set 'Input Src' = 05804:
 - This connects PSP1 Holdback Status
 - Set 'Reset Src' = 07176:LgOp1.OP
 - This connects Logic 1 Output to the Monitor Reset
 - Set 'Trigger' = 1.0
 - Set 'Day Alarm' = 0
 - Set 'Time Alarm' = 0:30:00:0
3. In STANDARD IO/AA Relay Page
 - Set 'Channel Type' = On/Off
 - Set 'Wire Src' = 03500:
 - This assigns AA Relay to Monitor OP

15.CHAPTER 13 TIMER, CLOCK, TOTALISER, OPERATION

15.1 WHAT ARE TIMER BLOCKS?

Timer Blocks allow the controller to use time/date information as part of the control process. They can be triggered by an event and used to initiate an action. For example, a programmer can be set to RUN at a particular day and time or an action delayed as a result of a digital input signal. The Timer Blocks page is only available if Timer Blocks has been enabled in configuration level. The Timer Blocks fitted in the 2604 controller are:

Four timer blocks	Timer blocks can have four modes of operation which are explained in Section 13.2. The timer type is set in Configuration level. The timer is activated by an event. The event is also defined in Configuration mode or it may be triggered by a parameter in the list. Timing continues for a set time period. The output can be 'wired' in configuration mode to operate a further event.
Clock	This is a real time clock which can be used to operate other time based functions.
Two alarm (clock) blocks	Alarms can be switched on or off at a particular day or time and provide a digital output. The alarm output can be wired in configuration mode to operate an event.
Four totaliser blocks	Totaliser blocks can also be 'wired', in Configuration level, to any parameter. They are used to provide a running total of a parameter and give an output when a pre-set total is reached. An example might be to totalise the flow through a pipe. The output can also be 'wired' in Configuration level to operate an event such as a relay.

Timer Blocks are grouped under page headers as follows:

TIMER BLOCKS ▶	Timer 1 Page	Parameters to set the time period and read elapsed time for timer 1
	Timer 2 Page	Parameters to set the time period and read elapsed time for timer 2
	Timer 3 Page	Parameters to set the time period and read elapsed time for timer 3
	Timer 4 Page	Parameters to set the time period and read elapsed time for timer 4
	Clock Page	To set time and day
	Alarm 1 Page	Parameters to set a time and day alarm and read the alarm output condition for alarm 1
	Alarm 2 Page	Parameters to set a time and day alarm and read the alarm output condition for alarm 2
	Totaliser1 Page	Parameters to read the totalised value, set and monitor an alarm on totalised value.
	Totaliser2 Page	Parameters to read the totalised value, set and monitor an alarm on totalised value.
	Totaliser3 Page	Parameters to read the totalised value, set and monitor an alarm on totalised value.
	Totaliser4 Page	Parameters to read the totalised value, set and monitor an alarm on totalised value.

15.2 TIMER TYPES

Each timer block can be configured to operate in four different modes. These modes are explained below

15.2.1 On Pulse Timer Mode

This timer is used to generate a fixed length pulse from an edge trigger.

- The output is set to On when the input changes from Off to On.
- The output remains On until the time has elapsed
- If the 'Trigger' input parameter recurs while the Output is On, the Elapsed Time will reset to zero and the Output will remain On
- The triggered variable will follow the state of the output

Figure 13.1 illustrates the behaviour of the timer under different input conditions.

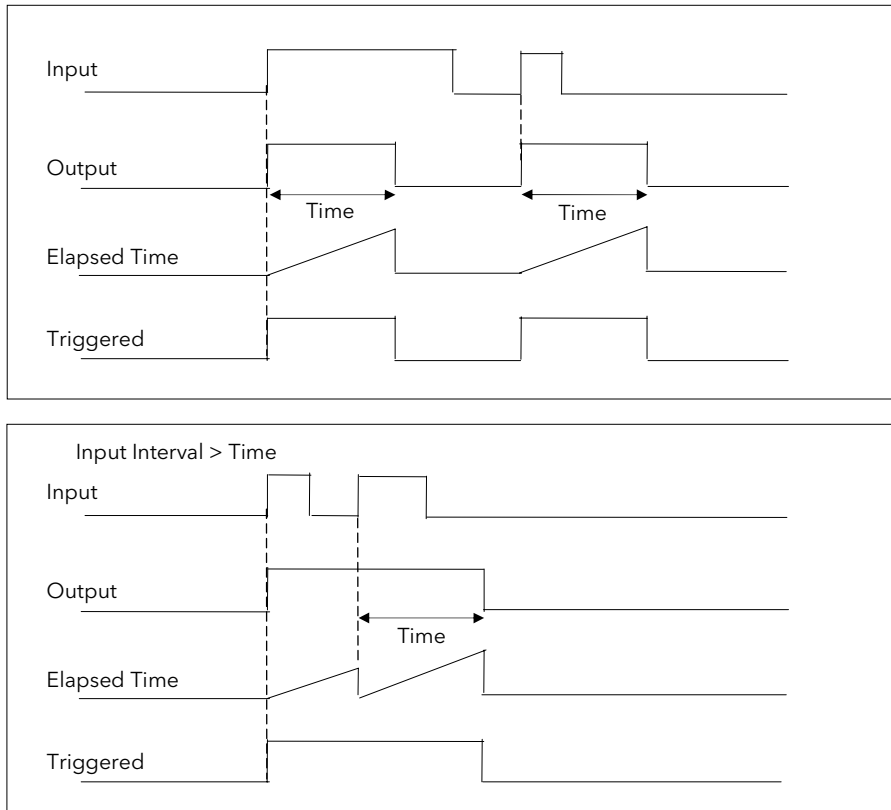


Figure 15-1: On Pulse Timer Under Different Input Conditions

15.2.2 Off Delay Timer Mode

This timer provides a delay between the trigger event and the Timer output. If a short pulse triggers the Timer, then a pulse of one sample time (110ms) will be generated after the delay time.

- The Output is set to Off when the Input changes from Off to On.
- The Output remains Off until the Time has elapsed.
- If the Input returns to Off before the time has elapsed, the Timer will continue until the Elapsed Time equals the Time. It will then generate a pulse of one Sample Time duration.
- Once the Time has elapsed, the Output will be set to On.
- The Output will remain On until the Input is cleared to Off.
- The Triggered variable will be set to On by the Input changing from Off to On. It will remain On until both the Time has elapsed and the Output has reset to Off.

Figure 13.2 illustrates the behaviour of the timer under different input conditions.

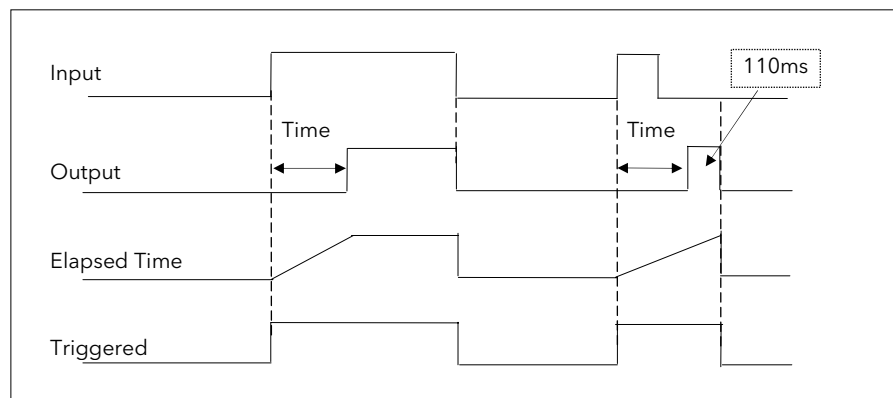


Figure 15-2: Off Delay Timer Under Different Input Conditions

15.2.3 One Shot Timer Mode

This timer behaves like a simple oven timer.

- When the Time is edited to a non-zero value the Output is set to On
- The Time value is decremented until it reaches zero. The Output is then cleared to Off
- The Time value can be edited at any point to increase or decrease the duration of the On time
- Once set to zero, the Time is not reset to a previous value, it must be edited by the operator to start the next On-Time
- The Input is used to gate the Output. If the Input is set, the time will count down to zero. If the Input is cleared to Off, then the Time will hold and the Output will switch Off until the Input is next set.

Note: since the Input is a digital wire, it is possible for the operator to NOT wire it, and set the Input value to On which permanently enables the timer.

- The Triggered variable will be set to On as soon as the Time is edited. It will reset when the Output is cleared to Off (Time reaches zero).

Figure 13.3 illustrates the behaviour of the timer under different input conditions.

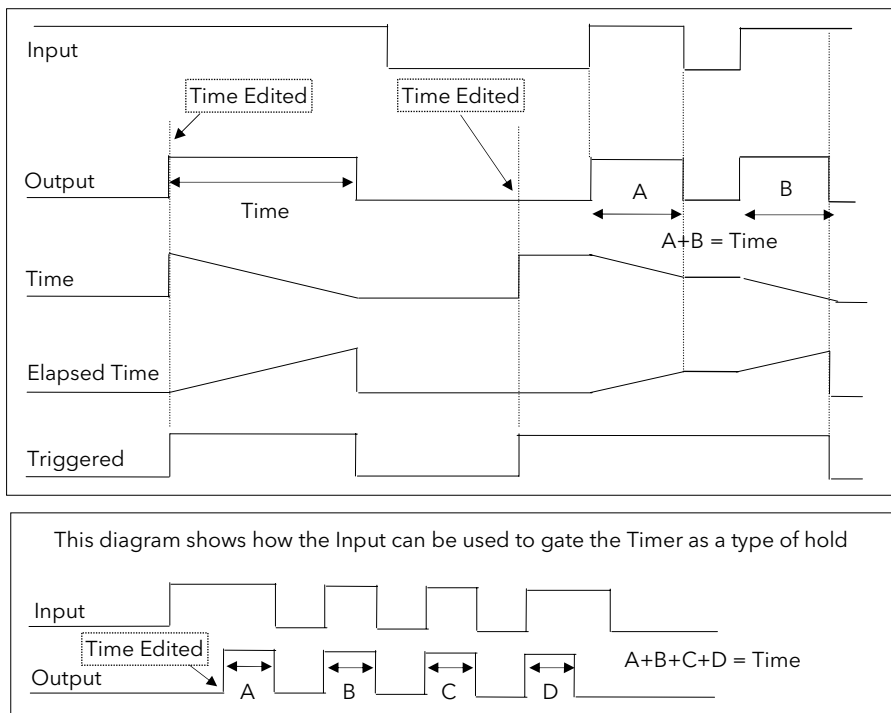


Figure 15-3: One Shot Timer

15.2.4 Minimum On Timer Mode

This timer has been targeted at guaranteeing that the output remains On for a duration after the input signal has been removed. It may be used, for example, to ensure that a compressor is not cycled excessively.

- The output will be set to On when the Input changes from Off to On.
- When the Input changes from On to Off, the elapsed time will start incrementing towards the set Time.
- The Output will remain On until the elapsed time has reached the set Time. The Output will then switch Off.
- If the Input signal returns to On while the Output is On, the elapsed time will reset to 0, ready to begin incrementing when the Input switches Off.
- The Triggered variable will be set while the elapsed time is >0 . It will indicate that the timer is counting.

Figure 13.4 illustrates the behaviour of the timer under different input conditions.

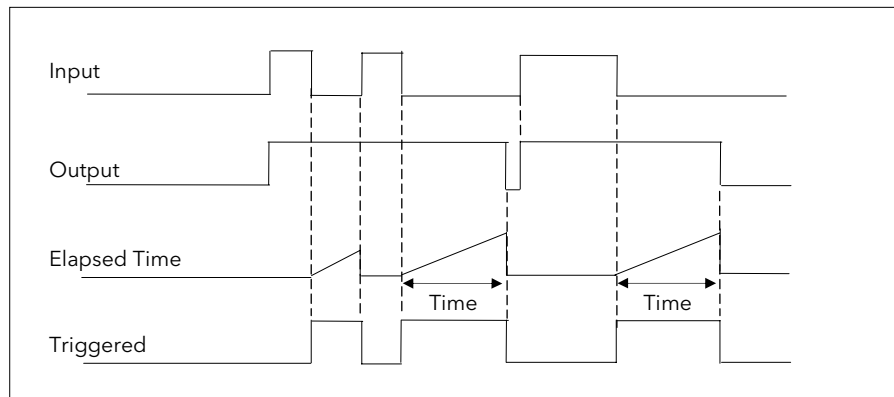







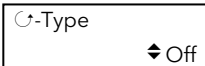


Figure 15-4: Minimum On Timer Under Different Input Conditions

15.3 TO VIEW AND ADJUST TIMER PARAMETERS

Do This	This Is The Display You Should See	Additional Notes																								
1. From any display press  as many times as necessary to select 'TIMER BLOCKS' 2. Press  or  to choose a Timer Page		This page is only available if 'Timer Blocks is Enabled in the INSTRUMENT (Options) page <table border="1"> <tr> <td colspan="2">Choices are:-</td> </tr> <tr> <td>Timer 1</td> <td>To configure</td> </tr> <tr> <td>Timer 2</td> <td>timer types</td> </tr> <tr> <td>Timer 3</td> <td>and</td> </tr> <tr> <td>Timer 4</td> <td>parameters</td> </tr> <tr> <td>Clock</td> <td>To set time and day</td> </tr> <tr> <td>Alarm 1</td> <td>To wire and</td> </tr> <tr> <td>Alarm 2</td> <td>set alarm outputs</td> </tr> <tr> <td>Totaliser 1</td> <td>To wire and</td> </tr> <tr> <td>Totaliser 2</td> <td>set totaliser</td> </tr> <tr> <td>Totaliser 3</td> <td>1, 2, 3 & 4</td> </tr> <tr> <td>Totaliser 4</td> <td>parameters</td> </tr> </table>	Choices are:-		Timer 1	To configure	Timer 2	timer types	Timer 3	and	Timer 4	parameters	Clock	To set time and day	Alarm 1	To wire and	Alarm 2	set alarm outputs	Totaliser 1	To wire and	Totaliser 2	set totaliser	Totaliser 3	1, 2, 3 & 4	Totaliser 4	parameters
Choices are:-																										
Timer 1	To configure																									
Timer 2	timer types																									
Timer 3	and																									
Timer 4	parameters																									
Clock	To set time and day																									
Alarm 1	To wire and																									
Alarm 2	set alarm outputs																									
Totaliser 1	To wire and																									
Totaliser 2	set totaliser																									
Totaliser 3	1, 2, 3 & 4																									
Totaliser 4	parameters																									
3. Press  to show the first parameter in the selected page - in this example 'Type' 4. Press  or  to select the timer type		Choices are: Off Min-On Timer One Shot Timer Off Delay Timer On Pulse timer																								






The full list of parameters is shown in the following table.
 They are selected and adjusted as described in the above procedure



15.3.1 Timer Parameters

Table Number: 13.3.1.	This page allows you to configure timer type and set up Timer Parameters	TIMER BLOCKS (Timer 1 to 4 Page)		
Parameter Name	Parameter Description	Value	Default	Access Level
Type	Timer type	Off On Pulse Timer Off Delay Timer One Shot Timer Min-On Timer	Off	Conf
Input Src	Timer input wire source	Modbus address		Conf
Time	Timer Time	0:00:00.0		L1
Input	Trigger/Gate input. Turn On to start timing	Off On	Off	L1
Triggered	Timer triggered (timing)	Off On		R/O L1
Output	Timer output. Occurs when the timer has timed out	Off On	Off	L1
Elapsed Time	Timer elapsed time	0:00:00.0		R/O L1

The above table is repeated for Timers 2 to 4.

 Tip: To change hours, minutes and seconds individually, press  and  together.
 This will highlight each area individually. Then use  or  to change the highlighted value.

The maximum settable time is 99:59:59.9

15.4 THE CLOCK

A real time clock is provided for use with various timer functions in the controller.

15.4.1 Clock Parameters

Table Number: 13.4.1.		This page allows you to configure the clock		TIMER BLOCKS (Clock Page)	
Parameter Name	Parameter Description	Value	Default	Access Level	
Mode	Real time clock mode	Run Stop Set		Conf	
Time	Real time clock time	HH:MM:SS		L1 R/O when Mode =Set	
Day	Real time clock day	Never Monday Tuesday Wednesday Thursday Friday Saturday Sunday Mon-Fri Mon-Sat Sat-Sun Every Day		L1 R/O when Mode =Set	

15.5 TIME BASED ALARMS

There are two alarms available which allow an output to be turned **on** or **off** at a set time and day.

15.5.1 Timer Alarm Parameters

Table Number: 13.5.1.		This page allows you to set up Timer Alarm Parameters		TIMER BLOCKS (Alarm 1 or 2 Page)	
Parameter Name	Parameter Description	Value	Default	Access Level	
Enable Src	Enable input wire source	Modbus address	None	Conf	
Enable	RTC Alarm 1 Enable Enables the timer alarm	Off On	Off	L1	
On-Day	Sets the day to turn the alarm on	Never Monday Tuesday Wednesday Thursday Friday Saturday Sunday Mon-Fri, Mon-Sat Sat-Sun Every Day	Never	L3	
On-Time	Sets the time of day to turn the alarm on	0:00:00 to 24:00:00	0:00:00	L3	
Off-Day	Sets the day to turn the alarm off	Never Monday Tuesday Wednesday Thursday Friday Saturday Sunday Mon-Fri, Mon-Sat Sat-Sun Every Day	Never	L3	
Off-Time	Sets the time of day to turn the alarm off	0:00:00 to 24:00:00	0:00:00	L3	
Output	Alarm 1 output.	Off On	Off	L1	

15.6 TOTALISERS

There are four totaliser function blocks which are used to measure the total quantity of a measurement integrated over time. A totaliser can, by soft wiring, be connected to any measured value. The outputs from the totaliser are its integrated value, and an alarm state. The user may set a setpoint which causes the alarm to activate once the integration exceeds the setpoint.

The totaliser has the following attributes:-

1. Run/Hold/Reset

In Run the totaliser will integrate its input and continuously test against an alarm setpoint.

In Hold the totaliser will stop integrating its input but will continue to test for alarm conditions.

In Reset the totaliser will be zeroed, and alarms will be reset.

2. Alarm Setpoint

If the setpoint is a positive number, the alarm will activate when the total is greater than the setpoint.

If the setpoint is a negative number, the alarm will activate when the total is lower (more negative) than the setpoint.

If the totaliser alarm setpoint is set to 0.0, the alarm will be off. It will not detect values above or below.

The alarm output is a single state output. It may be cleared by resetting the totaliser, or by changing the alarm setpoint.

3. The total is limited to a maximum of 99999 and a minimum of -9999.

15.6.1 Totaliser Parameters

Table Number: 13.6.1.		This page allows you to set up Totaliser Parameters		TIMER BLOCKS (Totaliser1 (to 4) Page)	
Parameter Name	Parameter Description	Value	Default	Access Level	
Input Src	Totaliser monitored parameter source	Modbus address		Conf	
Reset Src	Totaliser reset source	Modbus address		Conf	
Run Src	Totaliser run source	Modbus address		Conf	
Hold Src	Totaliser hold source	Modbus address		Conf	
Units	Totaliser units	See Appendix D2		Conf	
Resolution	Totaliser resolution	XXXXX XXXX.X XXX.XX XX.XXX X.XXXX	XXXXX	Conf	
Reset	Resets the totaliser	No Yes	No	L1	
Run	Runs the totaliser	Run Reset	Reset	L1	
Hold	Holds the totaliser at its current value Note: The Run & Hold parameters are designed to be wired to (for example) digital inputs. Run must be 'on' and Hold must be 'off' for the totaliser to operate.	Hold Continue	Hold	L1	
Total	This shows the totalised value	99999 to -9999		L1	
Alarm Setpoint	Sets the totalised value at which an alarm will occur			L3	
Alarm Output	This is a read only value which indicates the alarm output On or Off. The totalised value can be a positive number or a negative number. If the number is positive the alarm occurs when Total > + Alarm Setpoint If the number is negative the alarm occurs when Total > - Alarm Setpoint	Off On	Off	L1	
Input Val	Totaliser monitored value	-9999 to 99999		L1	

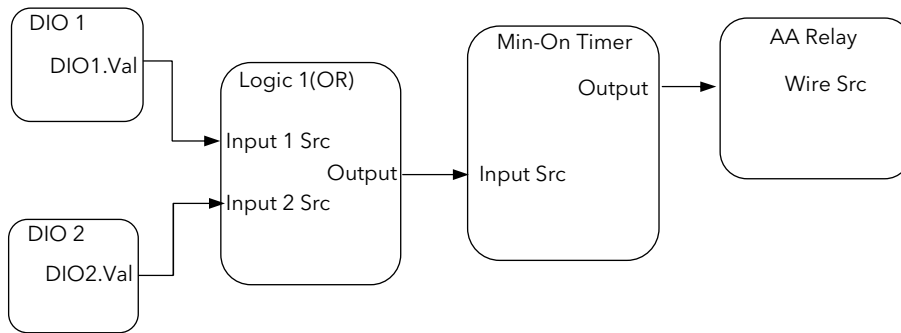
15.7 APPLICATION EXAMPLE

15.7.1 Compressor Timer

This example uses the Min-On Timer to start a compressor in an environmental chamber. The compressor must be kept running for 5 to 15 minutes after the controller stops calling for cooling. If the controller starts to call for cooling again the "compressor timeout" timer deactivates until the cooling turns off again. The same action is required for dehumidification.

15.7.1.1 Implementation

This example assumes that the controller has already been set up as a 2 loop temperature and humidity controller. The controller will call for the compressor to be switched on when either the cool or de-humidify outputs are switched on. The cool output is DIO1 and the de-humidify output is DIO2. The compressor output is the AA Relay.



Enter Config Mode	
In LOGIC OPERS/Logic 1 Page	Set "Operation" = OR Set "Input 1 Src" = 05402 :----- Set "Input 2 Src" = 05450:----- <i>(Connects cool and dehumidify outputs to the logic operator)</i>
In TIMER BLOCKS/Timer 1 Page	Set "Type" = Min-On Timer Set "Input Src" = 07176: LgOp1.OP Set "Time" = 0:10:00:0 <i>(Uses logic 1 to trigger timer)</i>
In STANDARD IO/AA Relay Page	Set "Channel Type" = On/Off Set "Wire Src" = 08963: Tmr1.OP <i>(Assigns AA Relay to Timer1 OP)</i>

16. CHAPTER 16 ADVANCED FUNCTIONS

16.1 PATTERN GENERATOR

The pattern generator allows groups of digital values to be selected from a single input number. This number is displayed as 'Pattern' and may be given a name, using the 'User Text' feature described in section 5.2.6. This is known as a 'User Enumeration'.

An example of an application for the Pattern Generator would be to allow fixed output patterns to be applied in different segments of a program. This may be useful where the same pattern is repeated in different segments or in other programs. It is achieved by soft wiring (see Chapter 3) to the 'Pattern Src' as shown in the example below.

The pattern generator consists of 16 patterns displayed as 'Pattern 0' to 'Pattern 15'. Each pattern consists of up to 16 digital outputs and any two patterns, displayed as 'Dig Group 1' and 'Dig Group 2', can be active at any one time.

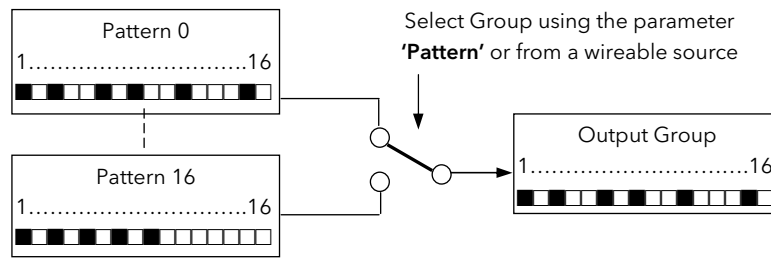


Figure 16-1: Digital Pattern Generator

16.1.1 Example: Programmer Event Outputs

In this example Program User Values are used to select the output pattern. The outputs of the pattern generator are wired to relay outputs of an IO Expander, see also Chapter 22. When Program User Value 1 = 0 then the digital values of pattern 0 will be active. When Program User Value 1 = 1 the digital values of pattern 1 will be active, and so on.

The patterns can also be enumerated so that each can be assigned a name. This will allow the operator to select, say, the "Heating Pattern" to be active within a program segment.

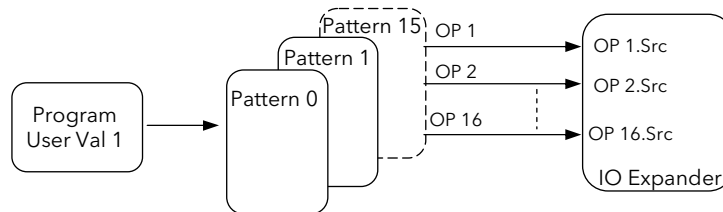


Figure 16-2: Pattern Selected by Programmer User Values

16.1.1.1 To Configure The Pattern Generator

Do This	This Is The Display You Should See	Additional Notes
1. From any display press as many times as necessary to select 'PATTERN GEN'		The PATTERN GEN page is only available if Enabled as described in section 5.2.
2. Press or to choose 'Dig Group 1 (or 2)'		
3. Press to show the first parameter in the selected page - in this example 'Pattern Src'		In this example Programmer User Value 1 is wired to the Pattern Source
4. Press or to select the Modbus address of the parameter you wish to wire to		
5. Press to show 'Pattern'		'Pattern' is read only when wired. It can only be used to select the pattern - 0 to 15- if it is not wired.
6. Press to show 'Patt High Lim'		'Pattern High Lim' can be used to limit the number of patterns in any particular application. A limit of 8 allows patterns 0 to 7
7. Press or to set the high limit value		
8. Press to show 'Pattern Enum'		This parameter allows you to select a name (or 'Enumeration') for the pattern.
9. Press or to select the 'User Text' which contains the appropriate message		See also section 5.3 for User Text examples and section 14.6 for enumeration examples.
10. Press to show 'Width', 'Current OP', Pattern 0'	 	'Width' limits the number of digits in each pattern between 1 and 16 - six in this example. 'Current OP' displays the currently selected output
11. Press or to change to change the first digit in the pattern to On (■) or Off (□)		Pattern 0 allows a set of on/off outputs to be configured for the selected pattern group.

16.1.1.2 Example: To Wire Pattern Generator Outputs to the IO Expander Inputs

Do This	This Is The Display You Should See	Additional Notes																
1. Enable the IO Expander in INSTRUMENT (Options) page		The modbus addresses of the digital outputs are: <table border="1"> <thead> <tr> <th colspan="2">Group 1</th> </tr> </thead> <tbody> <tr> <td>OP 1</td> <td>9973</td> </tr> <tr> <td>to</td> <td>to</td> </tr> <tr> <td>OP16</td> <td>9988</td> </tr> <tr> <th colspan="2">Group 2</th> </tr> <tr> <td>OP 1</td> <td>10037</td> </tr> <tr> <td>to</td> <td>to</td> </tr> <tr> <td>OP16</td> <td>10052</td> </tr> </tbody> </table>	Group 1		OP 1	9973	to	to	OP16	9988	Group 2		OP 1	10037	to	to	OP16	10052
Group 1																		
OP 1	9973																	
to	to																	
OP16	9988																	
Group 2																		
OP 1	10037																	
to	to																	
OP16	10052																	
2. Press as many times as necessary to select the 'IO EXPANDER' page																		
3. Press to select expander type e.g. '10 in 10 out' and confirm as instructed																		
4. Press to Scroll to 'OP 1 Src'																		
5. Press or to select the modbus address of Pattern Generator Digital OP 1																		

Tip:
Use the copy and paste procedure

16.2 ANALOGUE SWITCHES

Analogue Switches allow groups of analogue values to be selected from a single input number. This number may be provided from a user defined analogue source. or, if not wired, the analogue values can be selected from this number. As with the Pattern Generator the switch can be given a user defined name using the 'User Enumeration' feature.

There are 8 Analogue Switches, displayed as 'Switch 1' to 'Switch 7', and each switch can store up to 8 values displayed as 'Value 0' to 'Value 8'.

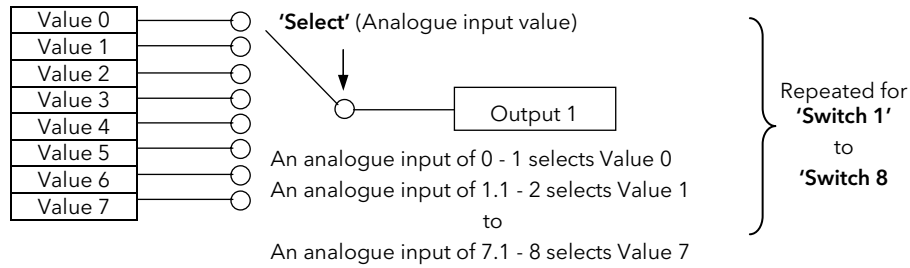


Figure 16-3: Representation of an Analogue Switch

16.2.1 To Set up an Analogue Switch

Do This	This Is The Display You Should See	Additional Notes
1. From any display press as many times as necessary to select 'ANALOG SWITCH'		The ANALOG SWITCH page is only available if Enabled as described in section 5.2.
2. Press or to select the required switch, e.g. 'Switch 1'		
3. Using button to scroll to the required parameter and or buttons to change the value of the parameter, set up the values as required		

The full list of parameters is shown in the following table.

They are selected and adjusted as described in the above procedure



16.2.2 Analogue Switch Parameters

Table Number: 14.2.2.		This page allows you to configure Analogue Switches		ANALOG SWITCH (Switch 1 to 8 Page)	
Parameter Name	Parameter Description	Value	Default	Access Level	
Units	To select units for the Switch	See Appendix D2	None	Conf	
Resolution	Analog switch resolution	XXXXX to X.XXXX	XXXXX	Conf	
Value Lo Limit	Values lower limit	Display range		Conf	
Value Hi Limit	Values higher limit	Display range		Conf	
Select Hi Lim	Select the upper limit of the number of switches required. If set to 5 the first 6 values can be selected	0 to 7	0	Conf	
Select Enum	User string for the enumeration of the switch	01:Usr1 to 50:Usr50	Not Enumerated	Conf	
Select Src	Modbus address for the source of the switch	Modbus address	None	Conf	
Select	Select the switch within the limit set 'Select Hi Lim'	0 to 7	0	L3	
Current OP	Current working output If an out of range 'Select' value is delivered by the 'Select Src' (when wired) 'Current OP' is always set to Value 0. i.e. Value 0 could be configured as the safe state value.			L3 R/O	
Value 0	Analog value 0	Display range		L3	
Value 1	Analog value 1	Display range		L3	
Value 2	Analog value 2	Display range		L3	
Value 3	Analog value 3	Display range		L3	
Value 4	Analog value 4	Display range		L3	
Value 5	Analog value 5	Display range		L3	
Value 6	Analog value 6	Display range		L3	
Value 7	Analog value 7	Display range		L3	

16.3 USER VALUES

User Values are normally used as constants in analogue or digital operations.


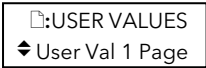



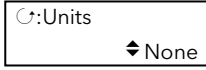


In an analogue operation the User Value may be used as a constant in a calculation.

In a digital operation it may be used to select an event. For example, it could be used to select a pattern from the pattern generator in the same way as the Programmer User Value was used in example 14.1.1.2. In this example the 'Program User Val 1' would be replaced by the 'User (1 to 12) Value'.

Each User Value can be given a user defined name using the 'User Enumeration' feature. This feature is generally intended for use when the User Value is used in a digital operation.

The 2604 controller contains up to 12 user values, which are in a single list under the page header 'USER VALUES'.

16.3.1 To Access User Values

Do This	This Is The Display You Should See	Additional Notes
1. From any display press  as many times as necessary to select 'USER VALUES'		The USER VALUES page is only available if Enabled as described in section 5.2. Up to 12 User Values can be chosen
2. Press  or  to select the required page		
3. Press  to select the first parameter in the list. In this case 'Units'		The choices are given in Appendix D2.
4. Press  or  to select units for the user value		

The list of User Value parameters available under this list header is shown in the following table.

They are selected and adjusted using the procedure described above




16.3.2 User Values Parameter Table

Table Number: 14.3.2. This page allows you to configure User Values		USER VALUES (User Val 1 Page)		
Parameter Name	Parameter Description	Value	Default	Access Level
Units	User value units	See Appendix D.2.		Conf
Resolution	User values resolution	XXXXX XXXX.X XXX.XX XX.XXX		Conf
Low Limit	User values low limit	Display min to display max		Conf
High Limit	User values high limit	Display min to display max		Conf
User 1 Value	User 1 value	User val lo lim to user val hi lim		L1
User Val Enu	Allows a name, chosen from User Text, to be given to the User Value	Not Enumerated 01:Usr1 to 50:Usr50	Not Enumerated	Conf

The above table is repeated for User Values 2 to 12.

Note: It is often required to generate a User Value = 1, and to wire this from a source. A User Value can be used for this but this takes up one or more of the User Values available.

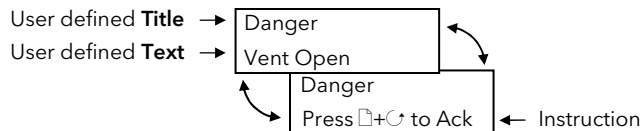
An alternative is to use the parameter 'Const.1' which is a User Value = 1. This parameter is listed in Appendix D.

 **Tip:** When using Custom Enumerations the Resolution should not be set to more than one decimal point since the User Text library is limited to 50 strings. See also Example 3 14.6.1.3.

16.4 USER MESSAGES

When the controller is in normal operating mode a user defined message may be made to appear on the lower display as a result of an event. The event may be derived from any parameter by defining its Modbus address when configuring the User Message feature.

The format of the message is shown below:-



The 'title' of the message is shown in the upper section of the lower display and the 'text' of the message is shown in the lower section. Both of these messages are chosen using User Text (section 5.3).




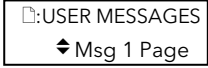



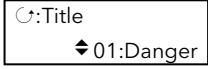



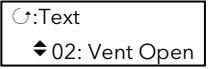



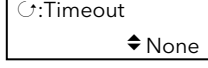



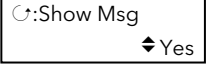



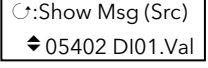
The message alternates with an instruction to acknowledge. When acknowledged the message disappears until the event becomes true once more. A timeout for the message may also be set when configuring the User Message feature.

User messages can only be set up in configuration level. They can, however, be inspected in Level 1.

Up to eight User Messages can be configured. Message 1 has a higher priority than Message 2 and so on.

The following example shows how to configure this user message so that it is displayed when digital input 01 becomes true.

16.4.1 To Configure A User Message




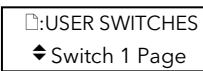



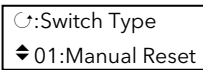








Do This	This Is The Display You Should See	Additional Notes
1. From any display press  as many times as necessary to select ' USER MESSAGES ' 2. Press  or  to select ' Msg 1 (to 8) '		In this example User message 1 is chosen
3. Press  to show the first parameter in the list. In this case ' Title ' 4. Press  or  to choose a user defined text set up as described in section 5.2.6.		In this example User Text 01 configured as 'Danger' is chosen
5. Press  to show ' Text ' 6. Press  or  to choose a user defined text set up as described in section 5.2.6.		In this example User Text 02 configured as 'Vent Open' is chosen
7. Press  to ' Timeout ' 8. Press  or  to set		If 'Timeout' is set to a value of:- 5 sec 10 sec 1 min 5 min or 10 min
9. Press  to ' Show Msg ' 10. Press  or  to choose ' Yes '		the user message will disappear after this period and will only re-appear when the digital input becomes true once more.
11. Press  to ' Show Msg (Src) ' 12. Press  or  to choose the Modbus address of the parameter which will trigger the message when the controller is in operation mode		The parameters ' Show Msg ' and ' Dismissed ' are intended for use over digital communications.

16.5 USER SWITCHES

User Switches are similar to User Values when the User Value is used in a digital operation. They may, however, be configured as Auto Resetting or Manual Resetting and typically utilised in 'User Pages' (see Chapter 15) to perform a specified task. A User Switch can be given a user defined name using the 'User Enumeration' feature described in previous pages.

Up to eight User Switches are available

16.5.1 To Configure User Switches

Do This	This Is The Display You Should See	Additional Notes
1. From any display press  as many times as necessary to select 'USER SWITCHES' 2. Press  or  to select 'Switch 1 (to 8)'		The USER SWITCHES page is only available if Enabled as described in section 5.2.
3. Press  to show the first parameter in the list. In this case 'Switch Type' 4. Press  or  to select the type		In this view the Switch Type is configured as Manual Reset. The alternative choice is Auto Reset.
5. Press  to show 'Switch Enum' 6. Press  or  to choose a user defined text set up as described in section 5.2.6.		The switch enumeration is chosen from User Text as '01:Open'. The Switch State toggles between User Text 01 and the next User Text 02.
7. Press  to 'Switch State' 8. Press  or  to set		In this example User Text 02 is configured as 'closed' so that the switch toggles between Open and Closed.

16.6 CUSTOM ENUMERATIONS

'Custom Enumerations' allow a user to enumerate parameter values with their own text.

Parameters which support custom enumerations are:-

- Program User Values - see section 6.5
- Digital Pattern Generator Inputs - see section 14.1
- Analogue Switches - see section 14.2
- User Switches - see section 14.5
- Digital Programmer Select parameter - see section 7.2.
- Digital IO Status parameters - see section 19.8
- Logic Operator 'Output Value' parameters - see section 17.2.1.

16.6.1 To Configure Custom Enumerations

This consists of two operations:-

1. Define areas of text in the INSTRUMENT/User Text page which are to be used for custom enumerations as follows:-

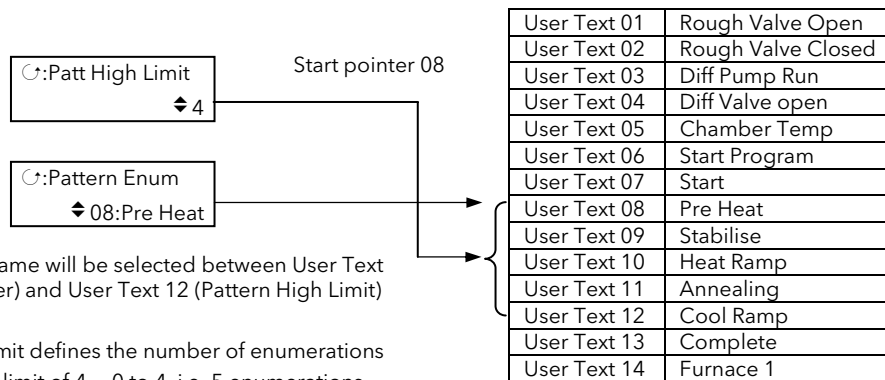
In INSTRUMENT/ User Text page Set User Text = Enabled
 Set 'Text Number' (from 1 to 50) to represent the beginning of the text area
 Configure the 'Text' for the required message using the ▲ or ▼ buttons to change the text and the ↻ button to move to the next character

The full procedure for this is described in section 5.2.6.

User Text 01	Rough Valve Open
User Text 02	Rough Valve Closed
User Text 03	Diff Pump Run
User Text 04	Diff Valve open
User Text 05	Chamber Temp
User Text 06	Start Program
User Text 07	Start
User Text 08	Pre Heat
User Text 09	Stabilise
User Text 10	Heat Ramp
User Text 11	Annealing
User Text 12	Cool Ramp
User Text 13	Complete

← This table shows an example of a text area

2. Set up a pointer which defines the start point from which the text is to be selected and the range of the user text, as follows:-
 - a. Choose the parameter to be enumerated, for example, 'Pattern Enum' in the PATTERN GEN (Dig Group 1 page)
 - b. Define the range of the user text
 - c. Choose the start point from which the user text is to be taken. Using the table below this user Text 08: Pre-Heat



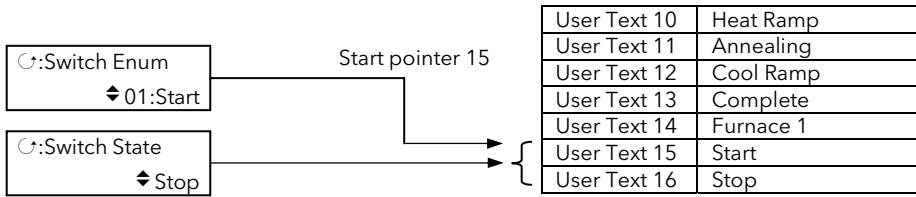
The 'Pattern' name will be selected between User Text 08 (start pointer) and User Text 12 (Pattern High Limit)

Pattern high limit defines the number of enumerations
 A Pattern high limit of 4 = 0 to 4 i.e. 5 enumerations

The following examples show how to apply this to different types of parameter.

16.6.1.1 User Switch

This is an example of a parameter which has just two states.



The enumeration shows two states Start and Stop

The procedure for configuring the above example is as follows

First set up the required user text as described in the previous section

Then:-

In USER SWITCHES/Switch 1 page, Set 'Switch Type' = Auto or Manual Reset

Set 'Switch Enum' = User Text 15 'Start'

Each time the or buttons is pressed the 'Switch State' will toggle between 'Start' or 'Stop'

16.6.1.2 Programmer User Values

In this example four enumerations will be allocated from User Text to Programmer User Value 1.

The User Text example which will be used is shown in this table:-

01 Usr1	Rough Valve Open		
02 Usr2	Rough Valve Closed		
03 Usr3	Diff Pump Run	} Start of enumerated text defined by paragraph 6 below Range of enumerated text defined by Low and High limits in paragraphs 3 & 4 below.	
04 Usr4	Diff Valve open		
05 Usr5	Chamber Temp		
06 Usr6	Start Program		
07 Usr7	Start		
08 Usr8	Pre Heat		

Do This	This Is The Display You Should See	Additional Notes
1. Select 'PROGRAM EDIT' (Options Page)		
2. Scroll to 'Prog Usr Val1?' and select 'Yes'		To enable Programmer User Value 1
3. Scroll to 'UVal 1 Low Lim' and select '0'		Range of enumerations is defined by 'Low Lim' and 'High Lim' If Low lim = 0 and High Lim = 3 range = 4
4. Scroll to 'UVal 1 Hi Lim' and select '3'		If Low lim = 1 and High Lim = 3 range = 3 The starting point is unaffected
5. Scroll to 'UVal 1 Name' and select a name for the Programmer User Value 1 from User Text if required		
6. Scroll to 'UVal 1 Enum' and select a start point from which the user text is to be taken		This defines the start point from which user text is taken

When a program is set up in PROGRAM EDIT (Segments Page) the parameter 'Prog User Val 1' can be give the enumerations 'Diff Pump Run'; 'Diff Valve open'; 'Chamber Temp'; or 'Start Program'.

17.CHAPTER 17 ANALOGUE OPERATORS

17.1 WHAT ARE ANALOGUE OPERATORS?

Analogue Operators allow the controller to perform mathematical operations on two input values. These values can be sourced from any available parameter including Analogue Values, User Values and Digital Values. Each input value can be scaled using a multiplying factor or scalar as shown in Figure 15.1.

The parameters to use, the type of calculation to be performed and the acceptable limits of the calculation are determined in Configuration level. In access level 3 you can change values of each of the scalars. In Access levels 2 & 3, provided the Analogue Operators page has been promoted, the input values and the result of the calculation can be read.

The Analogue Operators page is only available if Analogue and Logic Operators have been enabled in configuration level as described in section 5.2.

Up to 24 separate operations can be performed and a separate page header is provided for each one.

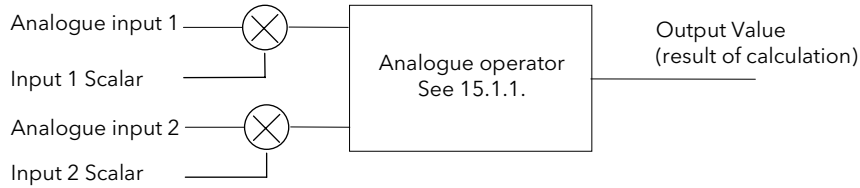









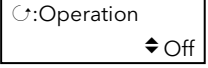
Figure 17-1: Analogue Operators

17.1.1 Analogue Operations

The following operations can be performed:

Off	The selected analogue operator is turned off
Add	The output result is the addition of Input 1 and Input 2
Subtract	The output result is the difference Input 1 and Input 2 where Input 1 > Input 2
Multiply	The output result is the multiplication of Input 1 and Input 2
Divide	The output result is Input 1 divided by Input 2
Absolute Difference	The output result is the absolute difference between Input 1 and 2
Select Max	The output result is the maximum of Input 1 and Input 2
Select Min	The output result is the minimum of Input 1 and Input 2
Hot Swap	Input 1 appears at the output provided input 1 is 'good'. If input 1 is 'bad' then input 2 value will appear at the output. An example of a bad input occurs during a sensor break condition.
Sample and Hold	Normally input 1 will be an analogue value and input B will be digital. The output tracks input 1 when input 2 = 1 (Sample). The output will remain at the current value when input 2 = 0 (Hold). Input 2 can be an analogue value and must change from 0 to 100% to provide a sample and hold at the output.
Power	The output is the value at input 1 raised to the power of the value at input 2. I.e. input 1 ^{input 2}
Square Root	The output result is the square root of Input 1. Input 2 has no effect.
Log	The output is the logarithm (base 10) of Input 1. Input 2 has no effect
Ln	The output is the logarithm (base n) of Input 1. Input 2 has no effect
Exp	The output result is the exponential of Input 1. Input 2 has no effect
10x	The output result is 10 raised to the power of Input 1 value. I.e. 10 ^{input 1} . Input 2 has no effect
Select Logic 1 up to Select Logic 32	Logic Operator 1 to 32 is used to control which Analogue Input is switched to the output of the Analogue Operator. If the output from the logic operator is true input 1 is switched through to the output. If false input 2 is switched through to the output. See example below:-

17.2 TO CONFIGURE ANALOGUE OPERATORS

Do This	This Is The Display You Should See	Additional Notes
<p>5. From any display press  as many times as necessary to select 'ANALOG OPERS'</p> <p>6. Press  or  to choose 'An 1 (to 24) Page'</p>		
<p>7. Press  to show the first parameter in the selected page - in this example 'Operation'</p> <p>8. Press  or  to choose the calculation to be performed by the Operation</p>		<p>The first parameter is 'Operation'.</p> <p>The choices are:</p> <p>Off, Add, Subtract, Multiply, Divide, Absolute Difference, Select Max, Select Min, Hot Swap, Sample Hold, Square Root, Log, Ln, Exp, 10x, Select Logic 1 to Select Logic 32.</p>

Remaining parameters in the Analogue Operators list are accessed and adjusted in the same way. The list of parameters available is shown in the following table



17.2.1 Analogue Operator Parameters

Table Number: 15.2.1. This page allows you to configure Analogue Operators 1 to 24			ANALOGUE OPERS (Analogue 1 Page)	
Parameter Name	Parameter Description	Value	Default	Access Level
Operation	The operation to be performed	See 15.1.1	Off	L1
Input 1 Src	Input 1 source	Modbus address		Conf
Input 1 Scalar	Input 1 scalar	Range depends on Input 1 Src		L3
Input 2 Src	Input 2 source	Modbus address		Conf
Input 2 Scalar	Input 2 scalar	Range depends on Input 2 Src		L3
OP Units	Output units	See Appendix D.2.		Conf
OP Resolution	Output resolution	XXXXX XXXX.X XXX.XX XX.XXX		Conf
Low Limit	Output low limit	Display min to display max		Conf
High Limit	Output high limit	Display min to display max		Conf
Default Enable	Enable fall back	Clip (Bad) Fallback (Bad) Clip (Good) Fallback (Good)		Conf
Default OP	Fall back value	Display min to display max		Conf
Input 1 Value	Input 1 Value	Display min to display max		L1
Input 2 Value	Input 2 Value	Display min to display max		L1
Output Value	output Value	Display min to display max		L1
Status	Status	Good Bad		L1

The above table is repeated for Analogue Operators 2 to 24.

18.CHAPTER 18 LOGIC OPERATORS

Logic Operators allow the controller to perform logical calculations on two input values. These values can be sourced from any available parameter including Analogue Values, User Values and Digital Values.

The parameters to use, the type of calculation to be performed, input value inversion and 'fallback' value are determined in Configuration level. In levels 1 to 3 you can view the values of each input and read the result of the calculation.

The Logic Operators page is only available if Analogue and Logic Operators have been enabled as described in section 5.2.

Up to 32 separate calculations can be performed and a separate page header is provided for each one.

18.1.1 Logic Operations

The following calculations can be performed:

Off	The selected logic operator is turned off
AND	The output result is ON when both Input 1 and Input 2 are ON
OR	The output result is ON when either Input 1 or Input 2 is ON
XOR	Exclusive OR. The output result is true when one and only one input is ON. If both inputs are ON the output is OFF.
Latch	The output is ON when input 1 turns ON. The output remains ON when input 1 turns OFF. The output is reset to OFF by turning input 2 ON.
Equal	The output result is ON when Input 1 = Input 2
Greater	The output result is ON when Input 1 > Input 2
Less than	The output result is ON when Input 1 < Input 2
Greater or Equal	The output result is ON when Input 1 ≥ Input 2
Less or Equal	The output result is ON when Input 1 ≤ Input 2

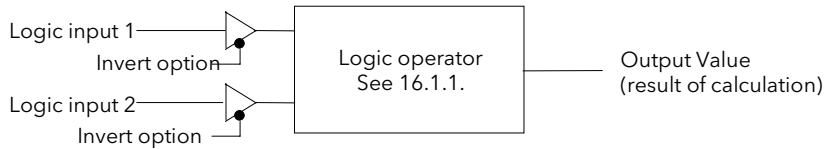


Figure 18-1: Logic Operators

18.2 TO CONFIGURE LOGIC OPERATORS

Do This	This Is The Display You Should See	Additional Notes
1. From any display press as many times as necessary to select ' LOGIC OPERS '		
2. Press or to choose ' Logic 1 (to 32) Page '		
3. Press to show the first parameter in the selected page - in this example ' Operation '		The first parameter is ' Operation '. The choices are: Off, AND, OR, XOR, Latch, Equal, Not Equal, Greater, Less Than, Great or Equal, Less or Equal.
4. Press or to choose the calculation to be performed by the Operation		

Remaining parameters in the Logic Operators list are accessed and adjusted in the same way.

The list of parameters available is shown in the following table



18.2.1 Logic Operator Parameters

Table Number: 16.2.1.		This page allows you to configure Logic Operators 1 to 32		LOGIC OPERS (Logic 1 Page)	
Parameter Name	Parameter Description	Value	Default	Access Level	
Operation	The logical operation to be performed	See Section 16.1.1.	Off	L1	
Input 1 Src	Input 1 source	Modbus address		Conf	
Input 2 Src	Input 2 source	Modbus address		Conf	
Invert	Invert inputs	None Invert Input 1 Invert Input 2 Invert Both		Conf	
Default OP	Fall back value (Does not appear if 'Operation' = Off)	0 or 1		Conf	
Input 1 Value	Input 1 Value	Off On		L3	
Input 2 Value	Input 2 Value	Off On		L3	
Output Value	Output Value	Off On Enumerated if 'OP Enum' = User defined text		L3	
Status	Status	Good Bad		L3	
OP Enum	User string for the first enumeration of the Output Value	Not Enumerated or choose from Usert Text	Not Enumerated	Conf	

The above table is repeated for Logic Operators 2 to 32.

19.CHAPTER 19 DIGITAL COMMUNICATIONS

19.1 WHAT IS DIGITAL COMMUNICATIONS?

Digital Communications (or 'comms' for short) allows the controller to communicate with a PC or a networked computer system. A choice of comms protocol is available and can be selected in configuration level. These are MODBUS (or JBUS), EIBisynch, Profibus and Devicenet.








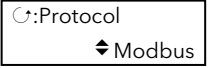



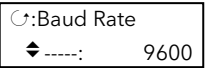
Comms modules can be fitted which use RS232, RS485 or RS422 Transmission Standards. A full description of these standards is given in the 2000 series Communications Handbook, part number HA026230.

Comms modules can be fitted into either or both of two positions referred to as the H slot and the J slot which correspond to the rear terminal connections, see also Installation section of the User Guide. Both slot positions may be used at the same time. An example is to allow a multi-drop connection between a number of controllers and a computer running, say, a SCADA package on one comms position, and a separate PC used for configuration purposes on the second comms position. In this example an RS485 module may be fitted for the multi-drop/SCADA requirement and RS232 in the second position for the single PC/configuration requirement.

Note: When the controller is placed into Configuration Level it is taken 'off line' and placed into a standby state. In this state it no longer monitors or controls the plant.

19.2 TO CONFIGURE COMMUNICATIONS PARAMETERS

The operation of the H and J Modules is the same.

Do This	This Is The Display You Should See	Additional Notes								
9. From any display press  as many times as necessary to select ' COMMS ' 10. Press  or  to choose the required page in this example ' H Module Page '		The choices are: <table border="1"> <tr> <td>H Module</td> <td>A comms module is fitted in the H slot</td> </tr> <tr> <td>J Module</td> <td>A comms module is fitted in the J slot</td> </tr> <tr> <td>Diagnostics</td> <td>Shows comms activity</td> </tr> </table>	H Module	A comms module is fitted in the H slot	J Module	A comms module is fitted in the J slot	Diagnostics	Shows comms activity		
H Module	A comms module is fitted in the H slot									
J Module	A comms module is fitted in the J slot									
Diagnostics	Shows comms activity									
11. Press  to show the first parameter ' Protocol ' 12. Press  or  to choose the comms protocol		The choices are: <table border="1"> <tr> <td>Modbus</td> <td></td> </tr> <tr> <td>EI Bisynch</td> <td></td> </tr> <tr> <td>Devicenet</td> <td></td> </tr> <tr> <td>Profibus</td> <td>if this has been ordered</td> </tr> </table>	Modbus		EI Bisynch		Devicenet		Profibus	if this has been ordered
Modbus										
EI Bisynch										
Devicenet										
Profibus	if this has been ordered									
13. Press  to ' Baud Rate ' 14. Press  or  to change the value		The choices are: <table border="1"> <tr> <td>Modbus</td> <td>4800, 9600, 19,200</td> </tr> <tr> <td>EI Bisynch</td> <td>4800, 9600, 19,200</td> </tr> <tr> <td>Devicenet</td> <td>125K, 250K, 500K</td> </tr> <tr> <td>Profibus</td> <td></td> </tr> </table>	Modbus	4800, 9600, 19,200	EI Bisynch	4800, 9600, 19,200	Devicenet	125K, 250K, 500K	Profibus	
Modbus	4800, 9600, 19,200									
EI Bisynch	4800, 9600, 19,200									
Devicenet	125K, 250K, 500K									
Profibus										

Remaining parameters are listed in the following table.
They are set up using the above procedure



19.2.1 H Module Parameters

Table Number: 17.2.1.		This page allows you to configure Digital Communications fitted in slot H.		COMMS (H Module Page)	
Parameter Name	Parameter Description	Value	Default	Access Level	
Protocol	Comms protocol	Modbus EI Bisynch Devicenet or Profibus ⁽¹⁾		L3	
Baud Rate	Baud rate (not shown if Profibus)	Modbus/ Bisynch: 9600, 19200, 4800 Devicenet: 125K, 250K, 500K	9600	Conf	
Parity	Parity (Modbus only)	None Even Odd	None	Conf	
Address	Mainboard controller address	Devicenet 0-63 Bisynch 1-99 Modbus 1-254 Profibus 0-127	1	L1	
Resolution	Comms resolution (Modbus only)	Full Integer	Full	L3	
Rx Timeout	H Comms timeout value (not shown if Devicenet)	None to 1:00:00		Conf	
H Activity	Comms activity in H module	0 or 1		L3 R/O	

Note 1

Profibus replaces EIBisynch if this option has been ordered. For Profibus instruments, only 'Address', 'Protocol' and 'Rx Timeout' parameters are displayed.

19.2.2 J Module Parameters

Table Number: 17.2.2.		This page allows you to configure Digital Communications fitted in slot J.		COMMS (J Module Page)	
Parameter Name	Parameter Description	Value	Default	Access Level	
Protocol	Comms protocol	Modbus EI Bisynch		L3	
Baud Rate	Baud rate (not shown if Profibus)	Modbus/ Bisynch: 2400, 4800 and 9600	9600	Conf	
Parity	Parity (Modbus only)	None Even Odd	None	Conf	
Address	Mainboard controller address	Bisynch 1-99 Modbus 1-254	1	L1	
Resolution	Comms resolution (Modbus only)	Full Integer	Full	L3	
J Activity	Comms activity in J module	0 or 1		L3 R/O	

19.3 DIGITAL COMMUNICATIONS DIAGNOSTICS

Digital communications diagnostics is available under the Comms page menu. Two parameters are displayed. The H Rx and J Rx messages increments each time a valid message is received via the H Comms Module or J Comms module respectively. The Timed Out messages indicate a comms time out.

They are displayed as follows:

Table Number: 17.3.		This page allows you to monitor the number of times that a particular comms module has received a message		COMMS (Diagnostic Page)	
Parameter Name	Parameter Description	Value	Default	Access Level	
H Rx Messages	Valid H comms messages received			L1	R/O
H Rx Timed Out	H Comms timeout			L1	R/O
J Rx Messages	Valid J comms messages received			L1	R/O
J Rx Timed Out	J Comms timeout			L1	R/O
Network Status ⁽¹⁾	Network status Only shown if the Profibus or Devicenet option is configured in the H Module	Running Initialising Ready Offline Bad GSD (Profibus only)		L1	R/O

Note 1

If Profibus is selected from the previous page, it will be necessary, either to power cycle the controller, or to switch to operation level before this parameter is displayed.

20.CHAPTER 20 MASTER COMMUNICATIONS

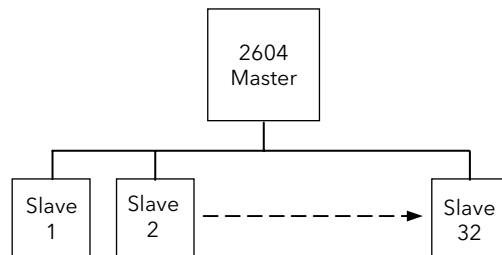
20.1 INTRODUCTION

Software version 5 and above of the 2604 controller supports Master Communications. The objective of the master comms is to allow the 2604 to communicate with any instrument using ModBus interface as a master device, that is, without the need for a supervisory PC. This allows the 2604 to link through digital communications with other products to create a small system solution. There are two methods of communication:-

1. Broadcast Communications
2. Direct Read/Write

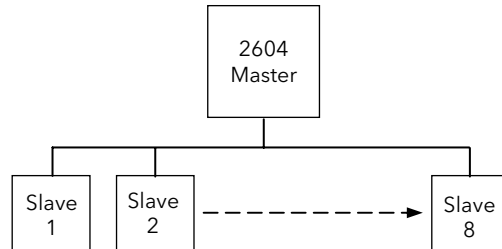
20.1.1 Broadcast Communications

The 2604 master can be connected to up to 32 slaves. The master sends a unit address of 0 followed by the address of the parameter which is to be sent. A typical example might be a multi zone oven where the setpoint of each zone is required to follow, with digital accuracy, the setpoint of a master.



20.1.2 Direct read/write

The 2604 master can be connected to up to eight slaves. Each slave has its own unit address. The master can send data to each slave by sending a unit address followed by the parameter address. It can also request data from a slave. This data may be displayed on the 2604 or used as part of a control strategy.



20.2 WIRING CONNECTIONS

Before proceeding further, please read Appendix B, Safety and EMC information, in the Installation and Operation Handbook.

The Digital Communications module for the master is fitted in Comms Module slot J and uses terminals JA to JF.

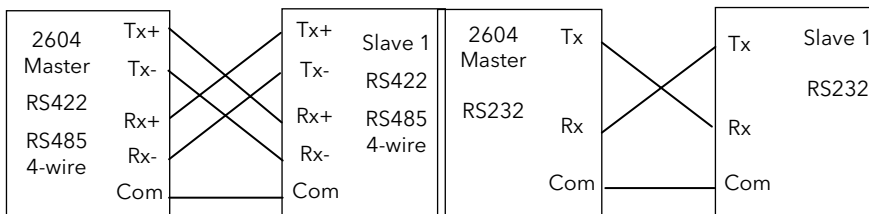
If the slave is a 2604 or 2704, the Digital Communications module can be fitted in either slot J or slot H

☺ Tip: RS422, RS485 4-wire or RS232

Rx connections in the master are wired to Tx connections of the slave

Tx connections in the master are wired to Rx connections of the slave

This is shown diagrammatically below



☺ Tip: RS485 2-wire

Connect A (+) in the master to A (+) of the slave

Connect B (-) in the master to B (-) of the slave

This is shown diagrammatically below

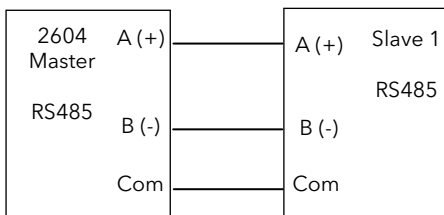


Figure 20-1: Master/Slave Connections

20.2.1 Example Wiring Diagrams for Different Slaves

The following diagrams show connections for a range of different controllers using RS422. These are representative of typical slaves which may be used but could also include third party products using Modbus protocol.

RS422 or RS485 4-wire

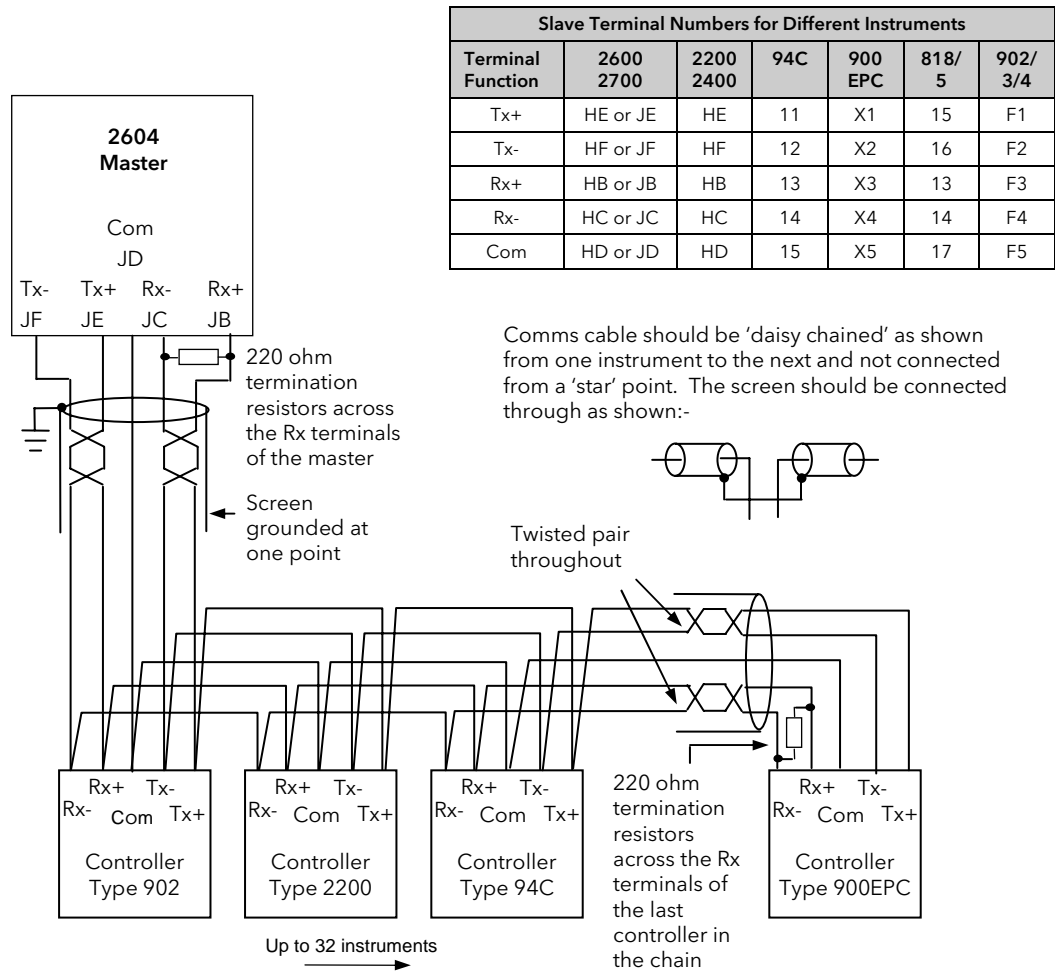


Figure 20-2: Example Wiring RS422 or RS485 4-wire for Different Slaves

RS485 2-wire

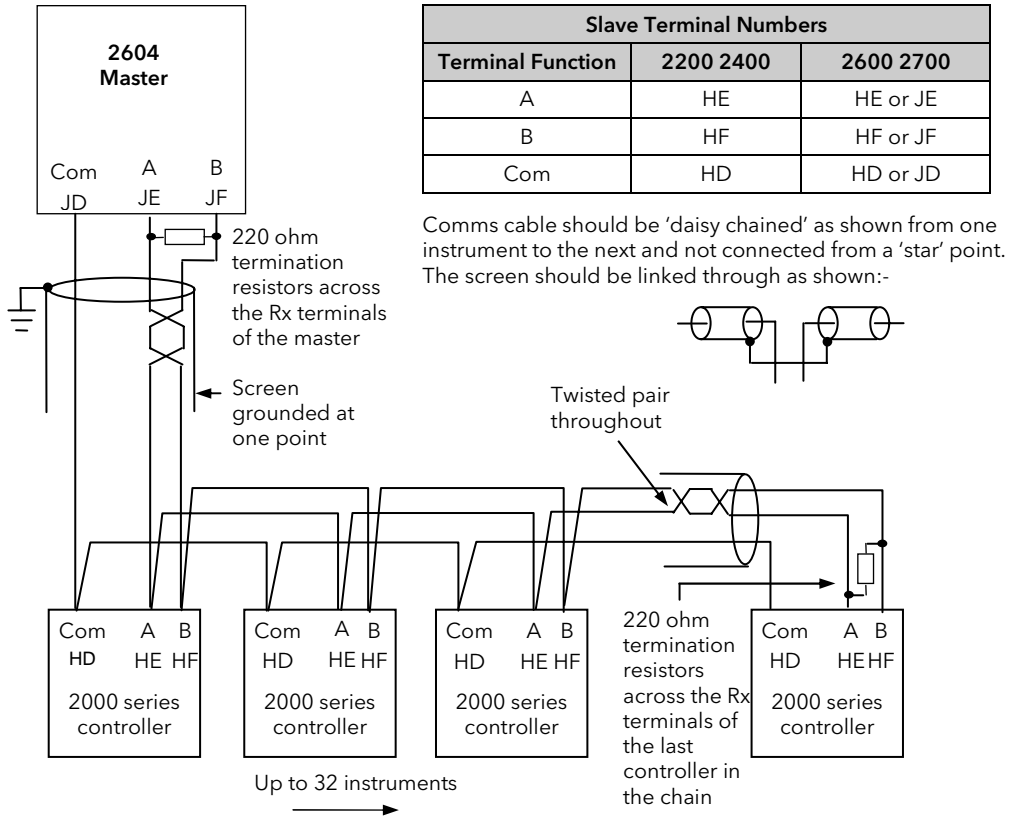


Figure 20-3: Example Wiring RS485 2-wire for 2000 Series Instruments

RS232

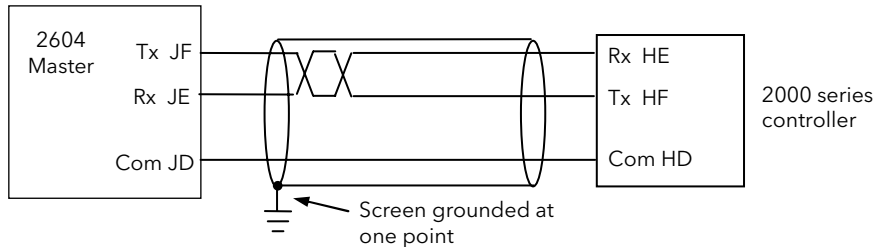


Figure 20-4: Example Wiring RS232 for 2000 Series Instruments

20.3 CROSS-BOARD VERSION

If master comms is fitted as an upgrade, check also the cross-board version before configuring master comms. This parameter can be found in configuration level in 'INSTRUMENT (Info Page) 'CBC Version' and must be greater than 4.7 (displayed as 47).

To configure the controller for master communications it will be necessary to navigate to configuration access level (see Engineering Handbook). A summary of navigation is shown below.










20.4 BASIC NAVIGATION

Parameters are organised into pages. Each page is given a name or header which describes a particular subject - in this case 'MASTER COMMS'

The MASTER COMMS page is divided into sub-headings, for example 'Parameters', 'Slave 1', etc

Parameters for the chosen subject are found in these pages

To change the value of alterable parameters

- press  to access the page
- press  or  to select the header
- press  to access
- press  or  to select the header
- press  again
- press  or 

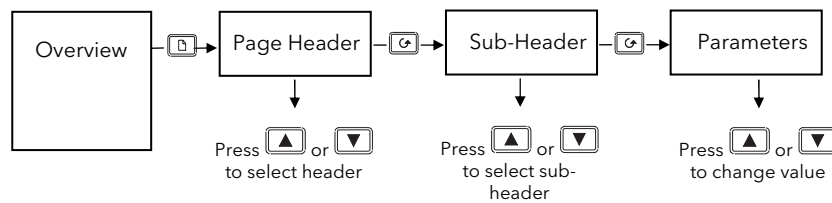









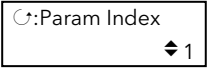



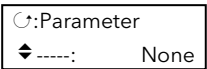
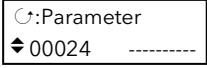






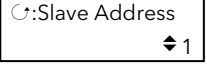



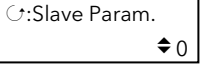



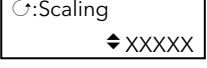



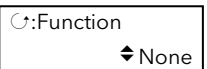



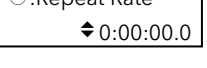
Figure 20-5: Summary of Basic Navigation

Examples are shown in the following two sections

20.5 TO CONFIGURE PARAMETERS

Set controller access level to **'Config'** as described in Chapter 4.





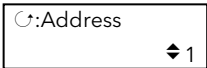


The parameters required to configure a transaction between a local parameter in the master and a parameter in the slave are shown in Table 18-1. To configure these parameters:-

Do This	This Is The Display You Should See	Additional Notes
1. From any display press  as many times as necessary to select 'MASTER COMMS' 2. Press  or  to choose the required page in this example 'Parameters Page'		These parameters configure a transaction between a local parameter in the 2604 and a parameter in a slave.
3. Press  to show the first parameter 'Param Index' 4. Press  or  to index the parameter 1 to 38		
5. Press  to select the 'Parameter' in the master 6. Press  or  to set the Modbus address of the parameter	 	In this example the parameter in the master is Loop 1 Setpoint (LP1_SETUP.SP.SP1) Commonly used parameters (see App. D - Engineering Handbook) are followed by a short description. To edit the parameter using this description press  to scroll to the description followed by  or 
7. Now press  to select the address of the slave in which to send (or receive) the parameter. 8. Press  or  to change the value		In this example the slave address is 1. For broadcast comms set this value to 0
9. Now press  to select 'Slave Parameter' address 10. Press  or  to change the value		Range 0 to 65535. This full range is only necessary for IEEE. It is necessary to give the full IEEE address to get true floating point. For example in Eurotherm controllers PV = 8002 Hex or 32770. (See also section 18.8.1.)
11. Now press  to select 'Scaling' for the parameter 12. Press  or  to change the value		See table 18-1 for choices
13. Now press  to select 'Function' 14. Press  or  to change the value		This sets the function to be read or write. See table 18-1 for full list of choices
15. Now press  to select 'Repeat Rate' 16. Press  or  to change the value		This sets the time between transmissions. 0 = continuous

20.6 TO CONFIGURE SLAVES

The controller must be in 'config' mode.

The parameters required to configure the characteristics of the slaves are shown in Table 18-2. To configure the slave parameters:-

Do This	This Is The Display You Should See	Additional Notes
1. From the MASTER COMMS menu press  or  to select the required slave		Up to eight slaves can be configured
2. Press  to select the first parameter in this list		The slave address is in the range 0 to 254 and does not necessarily have to be the same as the slave number. 0 is reserved for broadcast comms.
3. Press  or  to change the value		
Repeat 3 and 4 to set up following parameters.		See table 18-2 for a description of the parameters and settings

Remaining parameters are listed in the table 18-2.

They are set up using the above procedure



20.7 PARAMETER TABLES

Table Number: 18-1		These parameters configure a transaction between a local parameter in the 2604 and a parameter in a slave.	MASTER COMMS (Parameter Page)	
Parameter Name	Parameter Description	Value	Default	Access Level
Param. Index	Select up to 38 parameters to read or write to.	1 to 38		
Parameter	The address of the parameter in the 2604 which is to be sent to a slave. OR the address in the 2604 in which a parameter sent from a slave is stored.	modbus address shown as 'address' followed by 'name of commonly used parameter'		
Slave Address	The address of the slave where the parameter is to be sent or received. 0 is broadcast mode in which the parameter is sent to all slaves	0 to 254		
Slave Param.	The parameter address in the slave	0 to 65535		
Scaling	Scaling of the parameter in the slave No. of decimal points Time transmitted as seconds Time transmitted as minutes Time transmitted as hours Time transmitted as tenths of seconds Time transmitted as tenths of minutes Time transmitted as tenths of hours IEEE Float 32 bit (see section 18.8.1) Time transmitted as 32 bit msec	XXXXX sss mmm hhh ss.s mm.m hh.h Euro REAL Euro TIME		
Function See Note 1 below	Disables the transaction Set to Read(3) for parameters with modbus function code 3 Set to Read(4) for parameters with modbus function code 4 Set to Write to write at a repeat rate Set to Change Write to write only if the parameter value has changed	None Read(3) Read(4) Write Change Write		

Repeat Rate	Time between transmissions. 0 is continuous	0 to 99:59:59.9		
Status	Set to good on leaving config Slave returned illegal address Slave returned illegal value Slave returned Modbus exception Error in message returned by slave Value read was out of limits or the parameter is unalterable Parameter is OEM secured and will not be transmitted No response from slave The master has no parameter associated with the specified modbus address. Config only Parameter value unchanged since last transmit. Relevant to change write only. The slave does not support block write	Good Addr Error Data Error Error Failed Store Error Secured Timed Out No Parameter Unchanged No Block Write		

Note 1:-

Function codes are a single byte instruction to the slave describing the action to perform.

Function code 3 - Read Output Registers - allows the binary contents of holding registers to be obtained from the addressed slave.

Function code 4 - Read Input Registers - obtains the contents from input registers of the addressed slave.

For the 2000 range of controllers either function code can be used. For other slaves refer to the manufacturers documentation.

Table Number: 18-2		These parameters configure the characteristics of the slaves		MASTER COMMS (Slave 1 to 8 Page)	
Parameter Name	Parameter Description	Value	Default	Access Level	
Address	The modbus address of the slave	0 to 254			
Resolution	To set resolution configured in the slave to Full or Integer	Full Integer	Full		
Timeout(msecs)	Time to wait for a response from a slave	20 to 2000	100mS		
Retries	Number of times to retry before the status goes to 'Timed Out'	1 to 100	1		
Status	Offline and Online are user selectable. If the transaction is not completed in the time set by the 'Timeout' parameter in the specified number of 'Retries' the message 'Timeout' will be displayed. The message 'Recovering' appears fleetingly	Offline Online Timed Out Recovering			
Block Write	Set to the maximum block size supported by the slave. For IEEE this must be set to >0 (see also section 18.8.1)	0 to 100	0		

20.8 ADDITIONAL NOTES

20.8.1 IEEE in 2000 Series

This section applies specifically to 2000 series instruments. If the slave is not a series 2000 instrument, a knowledge of the communications format for the slave is required.

One of the main limitations of Modbus is that only 16 bit integer representations of data can normally be transferred. In most cases, this does not cause a problem, since appropriate scaling can be applied to the values without losing precision. If the slave is a series 2000 instrument, where all values are shown on a 4 digit display, values may be transferred in this way. However this has the significant drawback that the scaling factor to be applied needs to be known at both ends of the communications link.

One further problem is that certain 'time' parameters, notably those used for the programmer function can be returned over the communications link in tenths of seconds, minutes or hours. It is possible, therefore, for long durations to overflow the 16 bit Modbus limit.

To overcome these problems, a sub protocol has been defined, using the upper portion of the Modbus address space (8000h and upwards), allowing full 32 bit resolution floating point and timer parameters. This upper area is known as the IEEE region.

This sub-protocol provides two consecutive Modbus addresses for all parameters. The base address for any given parameter in the IEEE region can easily be calculated by taking its normal Modbus address, doubling it, and adding 8000h. For example, the address in the IEEE region of the Target Setpoint (Modbus address 2) is simply

$$2 \times 2 + 8000h = 8004h = 32772 \text{ decimal}$$

This calculation applies to any parameter in a series 2000 slave that has a Modbus address.

Access to the IEEE area is made via block reads (Functions 3 & 4) and writes (Function 16). Attempts to use the 'Write a Word' (Function 6) operation will be rejected with an error response. Furthermore, block reads and writes using the IEEE region should only be performed at even addresses, although no damage to the instrument will result in attempting access at odd addresses. In general, the 'number of words' field, in the Modbus frame, should be set to 2 times what it would have been for 'normal' Modbus.

The rules governing how the data in the two consecutive Modbus addresses are organised depending on the 'data type' of the parameter.

See also 'Series 2000 Communications Handbook Chapter 7.

20.8.2 Configuration mode

The Master does not communicate in configuration mode.

During configuration, if there is no parameter in the master with the specified Modbus address the Status is set to 'No Parameter' and on exit from configuration mode all parameters defining that transaction are set to their cold start values.

Parameter Name	Cold Start Value
Parameter	None
Slave Address	1
Slave Parameter	0
Repeat Rate	0:00:00.0
Function	None
Scaling	XXXXX
Status	Good

21.CHAPTER 21 STANDARD IO

21.1 WHAT IS STANDARD IO?

Standard IO refers to the fixed Input/Output connections as listed in Table 19-1 below. Parameters such as input/output limits, filter times and scaling of the IO can be adjusted in the Standard IO pages.

This chapter also describes **User Scaling** of the standard IO.

The controller is calibrated for life against known reference standards during manufacture, but user scaling allows you to offset the 'permanent' factory calibration to either:-

1. Scale the controller to your reference standards
2. Match the calibration of the controller to an individual transducer or sensor
3. To compensate for known offsets in process measurements

These offsets can be made to parameters in the Standard IO pages.

STANDARD IO ▶	<i>(PV Input Page)</i>	Allows access to parameters which set up the fixed Process Variable Input connected to terminals VH, VI, V+ and V-. This is, generally, the PV input for a single loop controller.
	<i>(An Input Page)</i>	Allows access to parameters which set up the fixed Analogue Input connected to terminals BA, BB and BC. This is the high level input from a remote source.
	<i>(AA Relay Page)</i>	Allows access to parameters which set up the fixed Relay output connected to terminals AA, AB and AC. This relay may be used as an alarm relay. a time proportioning control output or valve raise or lower..
	<i>(Dig IO1 Page)</i> to <i>(Dig IO7 Page)</i>	Allows access to parameters which set up the fixed digital IO connected to terminals D1 to D7 and DC.
	<i>(Diagnostic Page)</i>	Allows access to parameters which set up the fixed digital Input connected to terminal D8 and DC.

Note:-




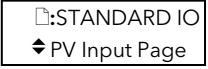







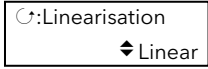



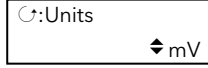



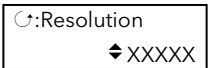
Names shown in *italics* can be customised.

Figure 21-1: Standard I/O

21.2 PV INPUT

The PV Input configures parameters associated with the fixed Process Variable Input connected to terminals VH, VI, V+ and V-. This is the PV input for a single loop controller.

21.2.1 To Configure Input Channel Type

Do This	This Is The Display You Should See	Additional Notes
1. From any display press  as many times as necessary to select 'STANDARD IO' 2. Press  or  to choose 'PV Input Page'		The PV Input is connected to terminals VH, V+, V-.
3. Press  to show the first parameter in the page, this is 'Channel Type' 4. Press  or  to select the channel type		The channel type can be:- RTD Thermocouple Pyrometer 40mV, 80mV (linear mV) mA, Volts (linear mA/volts) HZVolts (high impedance) Log 10 (logarithmic)
5. Press  to 'Linearisation' 6. Press  or  to select		Linearisation allows thermocouple, square root, linear or custom input curves to be configured for the selected channel type
7. Press  to 'Units' 8. Press  or  to select		This allows units to be allocated to the selected input type. A full list is given in Appendix D.2.
9. Press  to 'Resolution' 10. Press  or  to select		Configures the number of decimal points displayed

Remaining parameters in the Analogue Operators list are accessed and adjusted in the same way.

The list of parameters available is shown in the following table



21.2.2 Standard IO PV Input Parameters

Table Number: 19.2.2.		This page allows you to configure the PV Input Parameters		STANDARD IO (PV Input Page)	
Parameter Name	Parameter Description	Value	Default	Access Level	
Channel Type	Input/Output type	RTD, Thermocouple, Pyrometer 40mV, 80mV, mA, Volts, HZVolts, Log 10		Conf	
Linearisation	Input linearisation	See note 1		Conf	
Units	Engineering units	See Appendix D.2.		Conf	
Resolution	Display resolution	XXXXX to X.XXXX or SCI		Conf	
CJC Type	CJC type Only shown if 'Channel Type' = 'Thermocouple'	Internal 0°C 45°C 50°C None	Internal	Conf	
SBrk Impedance	Sensor break enable for certain high output impedance sensors	Off Low High	Off	Conf	
SBrk fallback	Sensor break fallback	Off Down scale Up Scale		Conf	
The following four parameters do not appear for 'Channel Type' = 'Thermocouple' or 'RTD'					
Electrical Lo	Electrical low input level	Input range		L3.	
Electrical Hi	Electrical high input level	Input range		L3	
Eng Value Lo	Low display reading	Display		L3	
Eng Value Hi	High display reading	range		L3	
Filter Time	PV input filter time.	Off to 0:10:00.0		L3	
Emissivity	Emissivity. Only appears if the PV input is configured as a pyrometer	Off to 1.00		L3	
Electrical Val	The current electrical value of the PV input	Input range		R/O L1	
PV Input Val	The current value of the PV input in engineering units.	Display range		R/O L1	
Offset	Transducer scaling offset.	Display range		R/O L3	
CJC Temp	CJC Temperature. Only appears if the PV input is configured for thermocouple	Display Range		R/O L1	
PV In Status	PV input status	See Appendix D3		R/O L1	
SBrk Trip Imp	Sensor break value	0 to 100% See section 19.3.3.		R/O L1	
PV Input Name	User defined name for PV input. Select from User Text Page Section 5.2.6.	User text	Default Text	Conf	
Cal State	Calibration state	See Ch 25		Conf	
Rear Term Temp	Temperature at the rear terminals	Auto See note 2		Conf	

Notes

1. Input Linearisation

J Type, K Type, L Type, R Type, B Type, N Type, T Type, S Type, Platinel II, C Type, PT 100, Linear, Square Root, Custom 1, Custom 2, Custom 3.

2. Rear Terminal Temperature

Auto means that the controller automatically measures the temperature at the rear terminals for use with cold junction compensation. The temperature of the rear terminals can be measured externally, if required, and this measured value can then be entered manually when calibrating CJC.

21.2.3 PV Input Scaling

Scaling of the PV input applies to linear process inputs only, eg linearised transducers, where it is necessary to match the displayed reading to the electrical input levels from the transducer. PV input scaling is not provided for direct thermocouple or RTD inputs.

Figure 19-1 shows an example of input scaling. where an electrical input of 4-20mA requires the display to read 2.5 to 200.0 units.

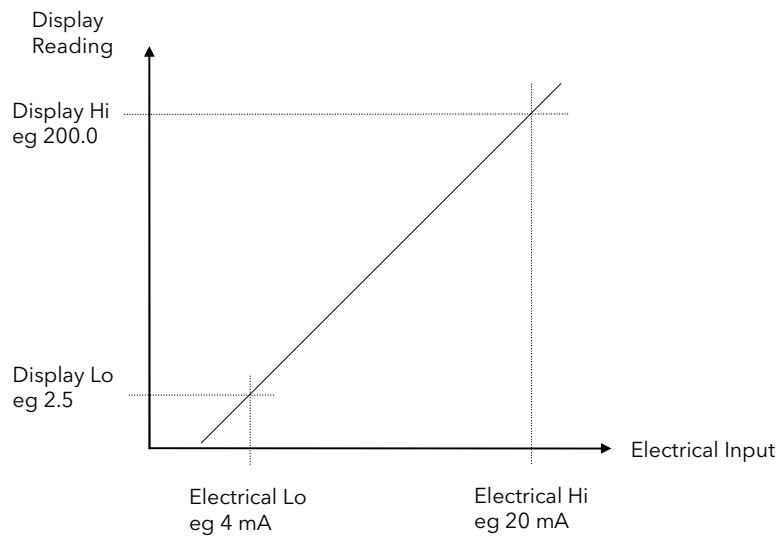













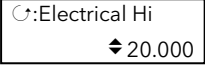







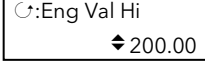
Figure 21-2: Input Scaling (Standard IO)

21.2.4 Offset

Offset has the effect of moving the whole curve, shown in Figure 19-2, up or down about a central point. The 'Offset' parameter is found in the STANDARD IO (PV Input) page.

21.2.5 To Scale a Linear PV Input

Using the example shown in Figure 19-2, proceed as follows: (This may be carried out at Access Level 3)

Do This	This Is The Display You Should See	Additional Notes
1. From any display press  as many times as necessary to select 'STANDARD IO' 2. Press  or  to choose 'PV Input Page'		
3. Press  to scroll to 'Electrical Lo' 4. Press  or  to 4mA		Set this value to the lowest level of the input, eg 4mA. The units displayed here may be mV, V, mA or Ohms depending on the type of input configured.
5. Press  to scroll to 'Electrical Hi' 6. Press  or  to 20mA		Set this value to the highest level of the input, eg 20mA.
7. Press  to scroll to 'Eng Val Lo' 8. Press  or  to 2.5		Set up the displayed value (instrument minimum span) which corresponds to the Electrical Lo input, eg 2.50
9. Press  to scroll to 'Eng Val Hi' 10. Press  or  to 200		Set up the displayed value (instrument maximum span) which corresponds to the Electrical Hi input, eg 200.00




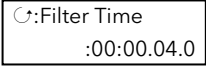
21.2.6 To View and Change Input Filter Time

An input filter provides damping of the input signal. This may be necessary to prevent the effects of excessive noise on the PV input.

The filter may be turned off or set in steps of 0.1sec up to 10mins

If the input is configured to accept process levels, eg 4-20mA, as in the above example, the parameter which follows 'Eng Value Hi' is 'Filter Time'.

For thermocouple and RTD inputs the first parameter to be displayed is the Input Filter Time, since the input scaling parameters do not appear for specific linearised inputs.

Do This	This Is The Display You Should See	Additional Notes
1. From the previous display press  to select 'Filter Time' 2. Press  or  to adjust the Filter Time between Off and 10mins		

21.3 ANALOGUE INPUT

The Analogue Input configures parameters associated with the fixed Analogue Input connected to terminals BA, BB and BC. This is the high level input from a remote source.

21.3.1 To Scale the Analogue Input

The procedure is the same as that described in section 19.2.5. The following table lists the parameters which set up this input

21.3.2 Standard IO *Analogue Input* Parameters

Table Number: 19.3.2.		This page allows you to configure the Analogue Input Parameters		STANDARD IO (<i>An Input Page</i>)
Parameter Name	Parameter Description	Value	Default	Access Level
Channel Type	Input/Output type	Volts mA		Conf
Linearisation	Input linearisation	See note 1		Conf
SBrk fallback	Sensor break fallback	Off Down scale Up Scale		Conf
SBrk Impedance	Sensor break enable for certain high output impedance sensors	Off Low High	Off	Conf
Units	Engineering units	See Appendix D.2.		Conf
Resolution	Display resolution	XXXXX to X.XXXX or SCI		Conf
Electrical Lo	Electrical low input level	Input range. Units depend on configuration		L3.
Electrical Hi	Electrical high input level			L3
Eng Value Lo	Low display reading	Display range. Units depend on configuration		L3
Eng Value Hi	High display reading			L3
Filter Time	PV input filter time	Off to 0:10:00.0		L3
Electrical Val	The current electrical value of the PV input	Input range		R/O
<i>An Input</i> Val	The current value of the Analogue input in engineering units <i>An Input</i> can be a user defined name.	Display range		R/O
Offset	Transducer scaling offset.			
An In Status	Status of the analogue input	OK Diagnostic messages are displayed to show the state of the Input if not OK. See Appendix D3		R/O
SBrk Trip Imp	Sensor break value	0 to 100% See 19.3.3.		R/O
An Input Name	User defined name for the analogue input. Select from User Text Page Section 5.2.6.		Default Text	Conf
Cal State	Calibration state	See Chapter 25		Conf

Notes

1. Input Linearisation

J Type, K Type, L Type, R Type, B Type, N Type, T Type, S Type, Platinel II, C Type, PT 100, Linear, Square Root, Custom 1, Custom 2, Custom 3.

21.3.3 Sensor Break Value

The controller continuously monitors the impedance of a transducer or sensor connected to any analogue input (including plug in modules described in the following chapter). This impedance, expressed as a percentage of the impedance which causes the sensor break flag to trip, is a parameter called 'SBrk Trip Imp' and is available in the parameter lists associated with both Standard and Module inputs of an analogue nature.

The table below shows the typical impedance which causes sensor break to trip for various types of input and high and low 'SBrk Impedance' parameter settings. The impedance values are only approximate ($\pm 25\%$) as they are not factory calibrated.

PV Input (Also applies to PV Input module and Dual PV Input module)		Analogue Input	
mV input ($\pm 40\text{mV}$ or $\pm 80\text{mV}$)		Volts ($\pm 10\text{V}$)	
SBrk Impedance - High	$\sim 10\text{K}\Omega$	SBrk Impedance - High	$\sim 50\text{K}\Omega$
SBrk Impedance - Low	$\sim 3\text{K}\Omega$	SBrk Impedance - Low	$\sim 10\text{K}\Omega$
Volts input (-3V to $+10\text{V}$) and HZ Volts input (-1.5 to 2V)			
SBrk Impedance - High		$\sim 500\text{K}\Omega$	
SBrk Impedance - Low		$\sim 100\text{K}\Omega$	

21.4 THE FIXED RELAY OUTPUT PARAMETERS

The fixed Relay output is connected to terminals AA, AB and AC. This relay may be used as an alarm relay, or a time proportioning control output.

21.4.1 Fixed Relay Output Scaling

If the relay is used as a time proportioning control output this means that the relay will, by default, be fully off for 0% power demand, fully on for 100% power demand and equal on/off times at 50% power demand.

As with input scaling you can change these limits to suit the process. It is important to note, however, that these limits are set to safe values for the process. For example, for a heating process it may be required to maintain a minimum level of temperature. This can be achieved by applying an offset at 0% power demand which will maintain the relay on for a period of time. Care must be taken to ensure that this minimum on period does not cause the process to overheat.

These offsets can be made to parameters in the 'AA Relay' pages. The above example is shown in Figure 19-3.

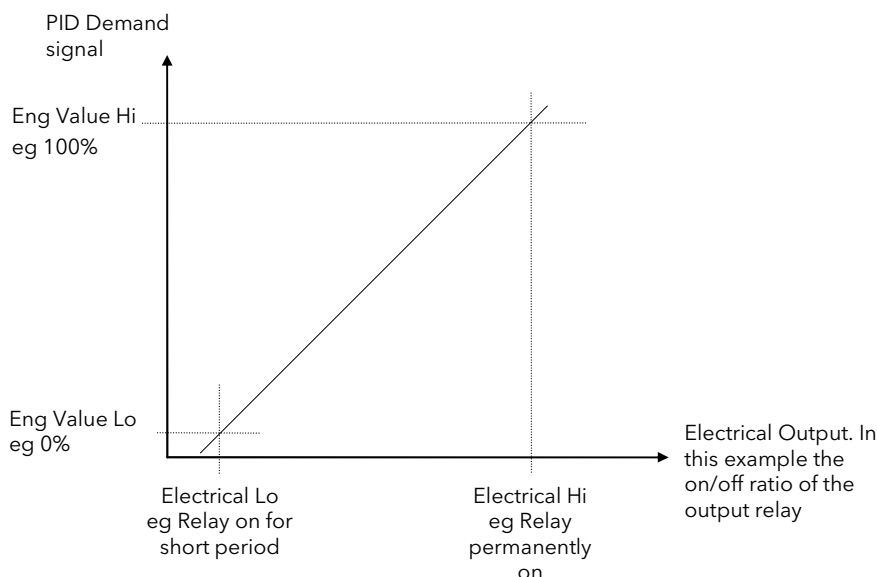



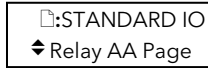



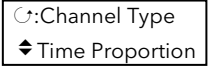



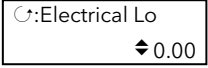



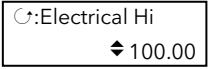







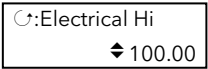


Figure 21-3: Fixed Relay Scaling

21.4.2 To Set up and Scale the Fixed Relay Output

Do This	This Is The Display You Should See	Additional Notes
1. From any display press  as many times as necessary to select 'STANDARD IO' 2. Press  or  to select the 'Relay AA Page'		This procedure can also be done in Level 3. The AA Relay is connected to terminals AA,AB and AC
3. Press  to show the first parameter in the list. This is 'Channel Type' 4. Press  or  to choose the function of the relay		The choices are:- On/Off Time proportion Valve Raise Valve Lower
5. Press  to scroll to 'Electrical Lo' 6. Press  or  to adjust the value		If the relay is wired to the PID output demand signal.set this to a low value, normally 0. If it is set to a higher value the relay will remain on for a period of time even when the PID demand is zero.
7. Press  to select 'Electrical Hi' 8. Press  or  to adjust the value		This parameter is limited by 'Electrical Hi' which may need to be adjusted first. If the relay is wired to the PID output demand signal.set this to a high value, normally 100.
9. Press  to select 'Eng Value Lo' 10. Press  or  to adjust the value		This is the value of the PID demand signal which will cause the relay to switch as set by 'Electrical Lo'
11. Press  to select 'Eng Value Hi' 12. Press  or  to adjust the value		This is the value of the PID demand signal which will cause the relay to switch as set by 'Electrical Hi'

21.4.3 Standard IO AA Relay Parameters

Table Number: 19.4.3		This table shows all parameters for the fixed relay output. They are accessed and adjusted as shown in the previous section.		STANDARD IO (AA Relay)	
Parameter Name	Parameter Description	Value	Default	Access Level	
Channel Type	Function of the relay	On/Off Time Proportion Valve Lower Valve Raise	As order code	Conf	
Wire Src	AA relay source	Modbus address		Conf	
Invert	Relay energised for 100% PID demand Relay de-energised for 100% power demand	Normal Inverted		Conf	
The following five parameters only appear if 'Channel Type' = 'Time Proportion'					
Min Pulse Time	Minimum relay on or off time Applies to time proportioning outputs only.	Auto = 0.05s or 0.1 to 999.9	20sec	L3	
Electrical Lo	Electrical low input level	Input range		L3	
Electrical Hi	Electrical high input level	Input range		L3	
Eng Value Lo	Low display reading	Display range		L3	
Eng Value Hi	High display reading			L3	
AA Relay Value ⁽¹⁾ AA Relay can be user text.	Status of the relay output See note 1	-100 to 100 -ve values not used	(editable if not wired)	R/O L3	
Electrical Val	The current (analogue) value of the output			R/O L3	
Channel Name	A name which replaces AA Relay from User Text			Conf	
Relay AA Val Enu See also 14.6.	Enumeration for the relay AA value on/off only	Not Enumerated	Not	Conf	
Elec Value Enum See also 14.6.	Enumeration for the electrical value on/off only	01:Usr1 to 50:Usr50	Enumerated	Conf	

Note 1: If the relay is wired to a source such as a loop output (Ch1 or Ch2) the 'value' will read in a positive direction only, i.e. it does not signify heating or cooling but just the position of the relay.

If configured for control 0 = Relay off; 100 = on; 1 to 99 = time proportioning

If configured as On/Off 0 = Relay Off; Any other value (+ or -) = Relay On

21.5 STANDARD IO DIG I/O PARAMETERS

This page allows access to parameters which set up the fixed digital IO connected to terminals D1 to D7 and DC.

The standard digital IO1 to 7 can either be input or output and is set up in configuration level. The choices are:-

1. Digital Input IO configured as a digital input
2. On/Off IO configured as a digital output
3. Time Proportion IO configured as a control output
4. Valve Lower IO configured to raise the output of a motor valve controller
5. Valve Raise IO configured to lower the output of a motor valve controller

The parameters which appear in the Dig IO pages depend upon the function ('Channel Type') configured. Choices for 'Channel Type' are shown in the following table.

When the logic outputs are configured as time proportioning outputs, they can be scaled in the same way as relay outputs already described.

21.5.1 Standard *Digital IO* Parameters

Table Number: 19.5.1.		This page allows you to configure the Digital I/O Parameters		STANDARD IO (<i>Dig IO1 to 7</i> Page)	
Parameter Name	Parameter Description	Value	Default	Access Level	
Channel Type	Input/Output type	Digital Input On/Off Time Proportion Valve Lower Valve Raise		Conf	
Wire Src	Source of the signal to operate a digital output. This parameter does not appear for a digital input	Modbus address		Conf	
Invert	Normal/inverted I/O	Normal / Inverted		Conf	
The following five parameters only appear if 'Channel Type' = 'Time Proportioning'					
Min Pulse Time	Minimum logic on or off time.	Auto = 0.05s or 0.1 to 999.9s	20sec	L3	
Electrical Lo	Electrical low input level	Input range		L3	
Electrical Hi	Electrical high input level			L3	
Eng Value Lo	Low display reading	Display range		L3	
Eng Value Hi	High display reading			L3	
<i>Dig IO1</i> Val ⁽¹⁾	If Channel Type = Digital Input this reads the state of the input If configured as an output this reads the desired output value	0 = Off 1 = On or -100 to 100		R/O L1	
Electrical Value ⁽¹⁾	If Channel Type = Digital Input this value does not appear If configured as an output this reads the actual electrical value.	0 or 1		R/O L3	
Channel Name	A name which replaces <i>Dig IOx</i> from User Text			Conf	
Dig IO Enum See also 14.6.	Enumeration for the electrical value on/off output or Digital Input only	Not Enumerated	Not Enumerated	Conf	
Elec Value Enum See also 14.6.	Enumeration for the electrical value on/off only	01:Usr1 to 50:Usr50		Enumerated	Conf

Note 1: Only settings between 0 & 100 are valid for Dig IO-Val. The corresponding Electrical value is shown in the following table:-

Channel Type	Dig IO- Val	Electrical Value
On/Off	0 to 100	0 to 1
Time Proportion	0 to 100	0.00 (off) to 1.00 (on). Time proportions between 0.00/1.00 for other positive settings of Dig IO- Val
Valve Raise/Lower	0 to 100	0.00 to 100.00

21.6 STANDARD IO DIAGNOSTIC PARAMETERS

This page allows you to configure a name for the digital input and to inspect its status or that of the IO Expander if fitted. The parameters are shown in the following table

21.6.1 Standard IO Diagnostic Parameters Table

Table Number: 19.6.1.		This page allows you to inspect Digital Input 8 or IO Expander status		STANDARD IO (Diagnostic Page)	
Parameter Name	Parameter Description	Value	Default	Access Level	
<i>Dig In8</i> Val	Status of digital input 8	Off On		R/O	
Dig In E1 Val	Status of IO expander input	Off On		R/O	
Bad Channels	A bad input or output will be displayed as ■ and will occur if the I/O is either a short or open circuit	□□□□□□□□ to ■■■■■■■■		R/O	
Dig In 8 Name	A name which replaces <i>Dig In8</i> from User Text			Conf	

22.CHAPTER 22 MODULE IO

22.1 WHAT IS MODULE IO?

Additional analogue and digital IO is provided by plug in IO modules, which can be fitted in any of five slots (These are also shown in 'Introduction' Chapter 1).

The type and position of any modules fitted in the controller is shown in the order code printed on the label on the side of the controller. This can be checked against the order code in Appendix A.

The module part number is printed on the side of the plastic case of the module.

Modules are available as single channel, two channel or three channel IO as listed below:-


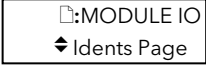

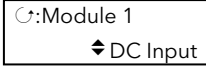

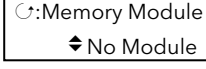
Module	Order Code	Idents Displayed As	Number of Channels	Module Part No.
Change over relay	R4	Form C Relay	1	AH025408U002
2 pin relay	R2	Form A Relay	1	AH025245U002
Dual relay	RR	Dual Relay	2	AH025246U002
Triac	T2	Triac	1	AH025253U002
Dual triac	TT	Dual Triac	2	AH025409U002
DC control	D4	DC Control	1	AH025728U003
DC retransmission	D6	DC Retrains	1	AH025728U002
PV input	PV	PV Input	1	AH026359U002
Triple logic input	TL	Tri-Logic IP	3	AH025317U002
Triple contact input	TK	Tri-Contact IP	3	AH025861U002
Triple logic output	TP	Tri-Logic OP	3	AH025735U002
24V transmitter supply	MS	Transmitter PSU	1	AH025863U002
5VdcTransducer power supply	G3	Transducer PSU	1	AH026306U002
10VdcTransducer power supply	G5	Transducer PSU	1	AH026306U002
Potentiometer input	VU	Pot Input	1	AH025864U002
Analogue input module (2604/2704 dc Input)	AM	DC Input	1	AH025686U004
Dual PV input (Dual Probe Input)	DP	Dual PV In	2	AH026359U003
Isolated single logic output	LO	Sin-Logic OP	1	AH025735U002
Dual DC output	DO	Dual DC Out	2	AH027249U002
High resolution DC retransmission output	HR	HR DC Out	2	AH027249U003

Table 22-1: I/O Modules

Parameters for the above modules, such as input/output limits, filter times and scaling of the IO, can be adjusted in the Module IO pages. The procedures are very similar to those covered in Chapter 19 'STANDARD IO'.

22.2 MODULE IDENTIFICATION

To identify which module is fitted into which slot:-

Do This	This Is The Display You Should See	Additional Notes
1. From any display press  as many times as necessary to access ' MODULE IO '		
2. Press  to show the first parameter in the list. This is ' Module 1 '		The 'Ident' page is read only. If a module is fitted in any module position, it's type, as listed in Table 20-1, is displayed. 'No Module' is displayed if the slot is empty.
3. Press  to show the next module position. This is ' Memory Module ' reserved for future use		

The parameters available in the 'Idents Page' are shown in the following table



22.2.1 Idents Page

Table Number: 20.2.1. This page allows you to read the type of module fitted.			MODULE IO (Idents Page)	
Parameter Name	Parameter Description	Module Message	Default	Access Level
Module 1	Actual module fitted	See note 1		L1 R/O
Memory Module	Memory module position	No Module		L1 R/O
Module 2 to 6	Actual module fitted	See note 1		L1 R/O

The module name is configurable by the user

Note 1:-

Module Messages



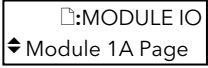

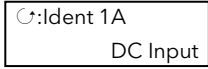



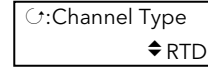



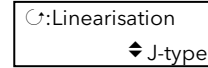
No Module	Bad Ident	Form C Relay	Form A Relay	Transducer PSU
Dual Relay	Dual Triac	DC Control	DC Retrains	Transmitter PSU
Tri-Logic IP	Tri-Contact IP	Tri-Logic OP	Pot Input	Diff Input
DC Input	Dual PV Input	Sin-Logic OP	Triac	
DC Control	HR DC Out	Dual DC Out	PV Input	

These are also listed in Table 20.1.

22.3 MODULE IO PARAMETERS

Each module has a unique set of parameters which depend on the function of the module fitted.

To view and alter parameters associated with each module:-

Do This	This Is The Display You Should See	Additional Notes
<p>1. From any display press  as many times as necessary to access 'MODULE IO'</p> <p>2. Press  to show 'Module 1A Page'</p>		<p>If a module is not fitted in the selected position the page is not displayed (A), (B), (C) refer to the output channel of a single, dual or triple module respectively The name of the module is user configurable</p>
<p>3. Press  to show the first parameter in the list. This is 'Ident 1A'</p>	 <p>Idents Summary of modules fitted <i>Module XA</i> X = Module number <i>Module XB</i> A, B, C = <i>Module XC</i> Single, Two, Three, channels respectively</p> <p>The above is repeated for every module fitted. The name of the module is user configurable</p>	<p>If the channel is not used the message 'No Parameters' is displayed</p>
<p>4. Press  to show the next parameter in the list. This is 'Channel Type'</p> <p>5. Press  or  to configure the function of the channel</p>		<p>The channel type is listed in each parameter table following this section. The channel type depends on the module type - input or output.</p>
<p>6. ' Press  again to scroll to a parameter which you wish to change</p> <p>7. Press  or  to change the parameter value</p>		<p>Tables in the following sections show the parameters available for different module types</p> <p style="text-align: center;">⇓</p>

22.3.1 DC Control and DC Retransmission

Table Number: 20.3.1.		This page allows you to configure a DC Output module for control or retransmission. This does not apply to the Dual DC or High Resolution Retranmission output modules		MODULE IO (Module 1(A))
Parameter Name	Parameter Description	Value	Default	Access Level
Ident	Module identification	DC Output		R/O
Channel Type	I/O type	Volts mA		Conf
Wire Src	Source to which the channel is wired	Modbus address		Conf
Electrical Lo	Electrical low input level	O/P range		L3. See output scaling
Electrical Hi	Electrical high input level	O/P range		
Eng Value Lo	Low display reading	Disp. range		
Eng Value Hi	High display reading	Disp. range		
Electrical Val	The current electrical value of the output in operation mode	0 to 10.00V or 0 to 20mA		R/O L3
<i>Module 1A</i> Val (can be a user defined name).	The current output value in operation mode.	±100.0% -ve values are not used		R/O L3
Cal Trim	Analogue output calibration trim. Only available in calibration mode. See 25.6.1.			Conf
Channel Name	User defined name for the channel. Select from User Text Page Section 5.2.6.		Default Text	Conf
Cal State	Calibration status	See 'Calibration' Chapter		R/O

This module has a single output. Its parameters are displayed under 'channel' (A).

22.3.2 Relay Output

Table Number: 20.3.2.		This page allows you to configure a Relay Output module. Types included:- Form C Relay; Form A Relay; Dual Relay.		MODULE IO (Module 7(A) Page)	
Parameter Name	Parameter Description	Value	Default	Access Level	
Ident	Module identification	Relay		R/O	
Channel Type	Channel/Module Type	On/Off Time Proportion Valve Lower Valve Raise		Conf	
Wire Src	Wire source	Modbus address		Conf	
Invert	Relay energised Relay de-energised	Normal Inverted		Conf	
The following five parameters only appear if Channel Type is set to Time Proportion.					
Min Pulse Time	Minimum relay on or off time	Auto = 0.05s or 0.07 to 150.00	5 sec	L3 Only shown for time proportioning O/Ps	
Electrical Lo	Electrical low input level	O/P range			
Electrical Hi	Electrical high input level	O/P range			
Eng Value Lo	Low display reading	Disp. range			
Eng Value Hi	High display reading	Disp. range			
Elect Val Enum See also 14.6.	Enumeration for the electrical value on/off only	Not Enumerated	Not Enumerated	Conf	
Eng Value Enum See also 14.6.	Enumeration for the engineering value on/off only	01:Usr1 to 50:Usr50		Conf	
Electrical Val	The current electrical value of the output in operation mode	0.00 or 1.00 (time prop)		R/O L3	
<i>Module 1A Val</i> <i>Module 1A can be user text.</i>	The current output value in operation mode.	$\pm 100.0\%$ -ve values are not used		R/O L3	
Channel Name	User defined name for the channel. Select from User Text Page Section 5.2.6.		Default Text	Conf	
The changeover relay and 2 pin relay are single output modules. The parameters above are displayed under 'channel' (A) only. Dual Relay has two outputs. The parameters above are displayed under Channel A and C.					

22.3.3 Triac Output

Table Number: 20.3.3.		This page allows you to configure a Triac Output module. Types included:- Triac; Dual Triac		MODULE IO (Module 7(A) Page)	
Parameter Name	Parameter Description	Value	Default	Access Level	
Ident	Module identification	Triac		R/O	
Channel Type	Channel/Module Type	On/Off Time Proportion Valve Lower Valve Raise		Conf	
Wire Src	Wire source	Modbus address		Conf	
Invert	Invert triac operation	Normal Inverted		Conf	
The following five parameters only appear if Channel Type is set to Time Proportion.					
Min Pulse Time	Minimum triac on or off time	Auto = 0.05s or 0.07 to 150.00	5 sec	L3 Only shown for time prop. O/Ps	
Electrical Lo	Electrical low input level	O/P range			
Electrical Hi	Electrical high input level	O/P range			
Eng Value Lo	Low display reading	Disp. range			
Eng Value Hi	High display reading	Disp. range			
Elect Val Enum See also 14.6.	Enumeration for the electrical value on/off only	Not Enumerated	Not Enumerated	Conf	
Eng Value Enum See also 14.6.	Enumeration for the engineering value on/off only	01:Usr1 to 50:Usr50		Conf	
Electrical Val	The current electrical value of the output in operation mode	0.00 or 1.00 (time prop)		R/O L3	
<i>Module 1A Val</i> <i>Module 1A</i> can be user defined text.	The current output value in operation mode.	±100.0% -ve values are not used		R/O L3	
Channel Name	User defined name for the channel. Select from User Text Page Section 5.2.6.		Default Text	Conf	
The triac output is a single output module. The parameters above are displayed under 'channel' (A) only. Channel (B) and channel (C) show 'No IO Channel'.					
The dual triac has two outputs. The parameters above are displayed under Channel (A) and Channel (C).					

22.3.4 Triple Logic Output and Single Isolated Logic Output

Table Number: 20.3.4.		This page allows you to configure a Logic Output module.		MODULE IO (Module 1(A) Page)	
Parameter Name	Parameter Description	Value	Default	Access Level	
Ident	Module identification	Logic Output		R/O	
Channel Type	Channel/Module Type	On/Off Time Proportion Valve Lower Valve Raise		Conf	
Wire Src	Wire source	Modbus address		Conf	
Invert	Invert logic operation	Normal Inverted		Conf	
The following five parameters only appear if Channel Type is set to Time Proportion.					
Min Pulse Time	Minimum on or off time	Auto = 0.05s or 0.07 to 150.00	Auto	L3 Only shown for time prop. O/Ps	
Electrical Lo	Electrical low input level	O/P range			
Electrical Hi	Electrical high input level	O/P range			
Eng Value Lo	Low display reading	Disp. range			
Eng Value Hi	High display reading	Disp. range			
Elect Val Enum See also 14.6.	Enumeration for the electrical value on/off only	Not Enumerated to	Not Enumerated	Conf	
Eng Value Enum See also 14.6.	Enumeration for the engineering value on/off only	01:Usr1 to 50:Usr50	Not Enumerated	Conf	
Electrical Val	The current electrical value of the output in operation mode	0.00 or 1.00 (time prop)		R/O L3	
<i>Module 1A Val</i> <i>Module 1A</i> can be user defined text.	The current output value in operation mode.	$\pm 100.0\%$ -ve values are not used		R/O L3	
Channel Name	User defined name for the channel. Select from User Text Page Section 5.2.6.		Default Text	Conf	
This module has three outputs. Each output is found under Module 1(A), (B) and (C).					

22.3.5 Triple Logic and Triple Contact Input

Table Number: 20.3.5.		This page allows you to set the parameters for a Triple Logic Input module.		MODULE IO (Module 1(A) Page)	
Parameter Name	Parameter Description	Value	Default	Access Level	
Ident	Module identification	Logic Input		R/O	
Channel Type	Channel/Module Type	Digital Input	Digital Input	Conf	
Invert	Invert input operation	Normal Invert		Conf	
Eng Val Enum See also 15.6	Enumeration for the Module 1A Val	Not Enumerated 01:Usr01 50:Usr50	Not Enumerated	Conf	
<i>Module 1A Val</i> <i>Module 1A</i> can be user defined text.	The current input value.	0 = Off 1 = On		R/O	
Channel Name	User defined name for the channel. Select from User Text Page Section 5.2.6.		Default Text	Conf	

This module has three inputs. Each input is found under Module 1(A), (B) and (C).

22.3.6 Transmitter Power Supply

Table Number: 20.3.6.		This page allows you to set the parameters for a Transmitter Power Supply module.		MODULE IO (Module 1(A) Page)	
Parameter Name	Parameter Description	Value	Default	Access Level	
Ident	Module identification	Transmitter PSU		R/O	
Channel Type	Input/Output type	Transmitter PSU	Transmitter PSU	Conf	
<i>Module 1A Val</i> <i>Module 1A</i> can be user defined text.	The current value in engineering units.			R/O	
Channel Name	User defined name for the channel. Select from User Text Page Section 5.2.6.		Default Text	Conf	

This module has a single output providing 24Vdc at 20mA. Its parameters are displayed under 'channel' (A).

22.3.7 Transducer Power Supply

Table Number: 20.3.7.		This page allows you to set the parameters for a Transducer Power Supply module.		MODULE IO (Module x(A) Page)	
Parameter Name	Parameter Description	Value	Default	Access Level	
Ident	Module identification	Transducer PSU		R/O	
Voltage	Voltage select	5 Volts 10 Volts			
Shunt	Selects calibration resistor fitted internally within the controller or externally (eg in the transducer)	External Internal			
Wire Src	Wire source	Modbus address			
Electrical Value	The current output electrical value in operation mode	0.00 to 10			
<i>Module 1A Val</i>	The current value in engineering units. <i>Module 1A</i> can be a user defined name.			R/O	
Channel Name	User defined name for the channel. Select from User Text Page Section 5.2.6.		Default Text	Conf	

This module has a single output. Its parameters are displayed under 'channel' (A).

22.3.8 Potentiometer Input

Table Number: 20.3.8.		This page allows you to set the parameters for a Potentiometer Input module.		MODULE IO (Module x(A) Page)	
Parameter Name	Parameter Description	Value	Default	Access Level	
Ident	Pot Input			R/O	
Units	Engineering units.	See Appendix D2		Conf	
Resolution	Display resolution	XXXXX to X.XXXX or SCI		Conf	
SBrk Fallback	Sensor break fallback	Off Downscale Upscale		Conf	
Eng Val Lo	Engineering value low	Display range		L3	
Eng Val Hi	Engineering value high			L3	
Filter Time	Input filter time	Off to 0:10:00.0		L1	
<i>Module 1A Val</i>	The current value in engineering units. <i>Module 1A</i> can be a user defined name.			R/O	
Module Status	Module status	See Appendix D3		R/O	
Channel Name	User defined name for the channel. Select from User Text Page Section 5.2.6.		Default Text	Conf	
Cal State	Allows the potentiometer to be calibrated.	Idle Pot Low Pos Pot High Pos Restore Fact	Idle	L3	
This module has a single input. Its parameters are displayed under 'channel' (A).					

22.3.9 PV Input

Table Number: 20.3.9.		This page allows you to set the parameters for a PV Input module. This module can only be fitted in slots 3 or 6.		MODULE IO (Module 3(A) Page)	
Parameter Name	Parameter Description	Value	Default	Access Level	
Ident	Module identification	PV Input		R/O	
Channel Type	Input/Output type	RTD Thermocouple Pyrometer 40mV 80mV mA Volts HZVolts Log10		Conf	
Linearisation	Input linearisation	See note 1		Conf	
Units	Engineering units	See Appendix D.2.		Conf	
Resolution	Display resolution	XXXXX to X.XXXX or SCI		Conf	
SBrk Impedance See section 21.5.3.	Sensor break enable for high output impedance sensors	Off / Low / High	Off	Conf	
SBrk fallback	Sensor break fallback	Off / Down scale / Up Scale		Conf	
CJC Type	CJC type Only shown if Channel Type = thermocouple	Internal 0°C / 45°C / 50°C None	Internal	Conf	
The following four parameters are only shown for 'Channel Type' = mV, Volts, mA, and HZVolts					
Electrical Lo [units]	Electrical low input level	Input range. units depend on channel type		L3. Only shown for mV, V, mA	
Electrical Hi [units]	Electrical high input level				
Eng Val Lo	Low display reading	Display range.			
Eng Val Hi	High display reading				
Filter Time	Input filter time	Off to 0:10:00.0		L1	
Emissivity	Emissivity Ch Type = pyrometer only	Off to 1.00			
Electrical Val [units]	The current electrical value of the input	Input range		R/O L3	
<i>Module 3A Val</i> <i>Module 3A can be</i> <i>user defined text.</i>	The current value in engineering units.			R/O	
CJC Temp	Temperature read at the rear terminals °C Ch Type = thermocouple only			R/O	
Offset	To apply a simple offset over the whole input range	Display range		L3	
Module Status	Module status See Appendix D3	OK or message		R/O	
SBrk Trip Imp	Sensor break value	See section 21.3.12.		R/O	
Channel Name	User defined name for the channel. Select from User Text Page Section 5.2.6.		Default Text	Conf	
Cal State	Calibration state Not shown for Pyrometer or mA inputs	See Chapter 25.		Conf	
Rear Term Temp	Allows a user measured offset to be entered for CJC calibration Ch Type = thermocouple only	Auto to 50.00°C			
This module has a single input. Its parameters are displayed under 'channel' (A).					

Notes

1. Input Linearisation

J Type, K Type, L Type, R Type, B Type, N Type, T Type, S Type, Platinel II, C Type, PT 100, Linear, Square Root, Custom 1, Custom 2, Custom 3.

22.3.10DC Input

Table Number: 20.3.10.		This page allows you to set the parameters for a DC Input module. This module can only be fitted in slots 1, 3, 4 or 6.		MODULE IO (Module x(A) Page)	
Parameter Name	Parameter Description	Value	Default	Access Level	
Ident	Module identification	DC Input		R/O	
Channel Type	Input/Output type	RTD Thermocouple Pyrometer mV mA Volts HZVolts Log10		Conf	
Linearisation	Input linearisation	See note 1		Conf	
Units	Engineering units	See Appendix D.2.		Conf	
Resolution	Display resolution	XXXXX to X.XXXX or SCI		Conf	
SBrk Impedance See section 21.5.3.	Sensor break enable for high output impedance sensors	Off / Low / High	Off	Conf	
SBrk fallback	Sensor break fallback	Off / Down scale / Up Scale		Conf	
CJC Type	CJC type Only shown if Channel Type = thermocouple	Internal 0°C / 45°C / 50°C None	Internal	Conf	
The following four parameters are only shown for 'Channel Type' = mV, V, mA, and HZVolts					
Electrical Lo	Electrical low input level	Input range units depend on channel type		L3. See 'To Scale the PV Input'	
Electrical Hi	Electrical high input level				
Eng Value Lo	Low display reading	Display range			
Eng Value Hi	High display reading				
Filter Time	Input filter time	Off to 0:10:00.0		L3	
Emissivity	Emissivity Pyrometer input only	Off to 1.00		L3	
Electrical Val	The current electrical value of the input	Input range units as configured		R/O	
<i>Module 3A (or 6A) Val</i>	The current value in engineering units. <i>Module 3A</i> can be a user defined name.			R/O	
Offset	Transducer scale offset	Display range	0	L3	
CJC Temp	Temperature read at the rear terminals °C Thermocouple inputs only			R/O	
Module Status	Module status	See Appendix D3		R/O	
SBrk Trip Imp	Current sensor break value Read as a % of the SBrk Impedance configured	See section 21.5.3.		R/O	
Channel Name	User defined name for the channel. Select from User Text Page Section 5.2.6.		Default Text	Conf	
Cal State	Allows input to be calibrated. Not shown for Pyrometer or mA inputs	See Chapter 25	Idle	Conf	
Rear Term Temp	Allows a user measured offset to be entered for CJC calibration Ch Type = thermocouple only	Auto to 50.00°C			
This module has a single input. Its parameters are displayed under 'channel' (A).					

Notes

1. Input Linearisation

J Type, K Type, L Type, R Type, B Type, N Type, T Type, S Type, Platinel II, C Type, PT 100, Linear, Square Root, Custom 1, Custom 2, Custom 3.

22.3.11 Dual PV Input

The dual PV input module accepts two inputs - one from a high level source (channel A) and one from a low level source (channel C). The two inputs are not isolated from each other and have an update rate of 5Hz. One application for the module is for a zirconia probe input.

The module can also be configured for a single input when the update rate becomes 10Hz.

Table Number: 20.3.11A.		This page allows you to set the parameters for Channel A of a Dual PV Input module. This module can only be fitted in slots 3 or 6.		MODULE IO (Module 3(A) Page)	
Parameter Name	Parameter Description	Value	Default	Access Level	
This module has two inputs. Parameters are displayed under 'channel' (A) and 'channel' (C) Channel A is the high level input, channel C is the low level input. This assumes that 'En Dual Mode' = 'Yes' in the Channel C menu. If 'En Dual Mode' = 'No', then this module will behave as a single PV Input module, see table 20.3.9. This table shows Module 3 (or 6)A parameters					
Ident	Channel identification	High Level Inp		R/O	
Channel Type	Input/Output type	HZ Volts Volts	DC Input	Conf	
Linearisation	Input linearisation	See note 1		Conf	
Units	Engineering units	See Appendix D2		Conf	
Resolution	Display resolution	XXXXX to X.XXXX or SCI		Conf	
SBrk Impedance	Sensor break impedance for sensors with high output impedance	Off Low High	Off	Conf	
SBrk Fallback	Sensor break fallback	Off Downscale Upscale		Conf	
Electrical Lo	Electrical low input level	Input range units depend on channel type		L3 See 'To Scale the PV Input' L3	
Electrical Hi	Electrical high input level				
Eng Val Lo	Low display reading				
Eng Val Hi	High display reading				
Filter Time	Input filter time	Off to 0:10:00.0			
Electrical Val	The current electrical value of the input	Input range units as configured		R/O	
Module 3A Val	The current value in engineering units. <i>Module 3 (or 6)A</i> can be a user defined name.			R/O	
Offset	Transducer scale offset	Range limits			
Module Status	Module status	See Appendix D		R/O	
SBrk Trip Imp	Current sensor break value Read as a % of the SBrk Impedance configured	See section 20.5.3.		R/O	
Channel Name	User defined name for the channel. Select from User Text Page Section 5.2.6.		Default Text	Conf	
Cal State	Allows input calibration Only shown when 'En Dual Mode' = 'No' (Table 21.3.11c)	See Chapter 25	Idle	Conf	

Notes

1. Input Linearisation

J Type, K Type, L Type, R Type, B Type, N Type, T Type, S Type, Platinel II, C Type, PT 100, Linear, Square Root, Custom 1, Custom 2, Custom 3.

Table Number: 20.3.11C.		This page allows you to set the parameters for Channel C of a Dual PV Input module. This module can only be fitted in slots 3 or 6.		MODULE IO (Module 3(C) Page)	
Parameter Name	Parameter Description	Value	Default	Access Level	
This module has two inputs. Parameters are displayed under 'channel' (A) and 'channel' (C) Channel A is the high level input, channel C is the low level input. This table shows Module 3 (or 6)C parameters					
Ident	Channel identification	Low Level Inp		R/O	
Channel Type	Input/Output type	DC Input	DC Input	Conf	
En Dual Mode	Enable dual mode See note 2	Yes No			
Linearisation	Input linearisation	See note 1		Conf	
Units	Engineering units	See Appendix D2		Conf	
Resolution	Display resolution	XXXXX to X.XXXX or SCI		Conf	
SBrk Impedance	Sensor break impedance for high impedance output sensors	Off Low High	Off	Conf	
SBrk Fallback	Sensor break fallback	Off Downscale Upscale		Conf	
CJC Type	CJC type Only shown if Channel Type = Thermocouple	Internal 0°C 45°C 50°C None	Internal	Conf	
Filter Time	Input filter time	Off to 0:10:00.0		L3	
Emissivity	Emissivity Only shown if Channel Type = Pyrometer	Off to 1.00		L3	
Electrical Val	The current electrical value of the input	Input range units depend on channel type		R/O	
<i>Module 3A Val</i>	The current value in engineering units. <i>Module 3 (or 6)A</i> can be a user defined name.			R/O	
Offset	Transducer scale offset	Range limits			
CJC Temp	Temperature read at the rear terminals °C Thermocouple inputs only			R/O	
SBrk Trip Imp	Current sensor break value Read as a % of the SBrk Impedance configured	See also section 20.5.3.		R/O	
Channel Name	Channel name		Default Text	R/O	

Note 2:-

The parameters in the above two tables are displayed when '**En Dual Mode**' = '**Yes**'

If '**En Dual Mode**' = '**No**', then the module can be used as a single input with an update rate of 10Hz. Channel C parameters are then not applicable and the list of Channel A parameters becomes identical to the parameter list for the single PV Input module, see section 20.3.9

To calibrate the module it is necessary to set '**En Dual Mode**' = '**Yes**'

22.3.12 Dual DC Output Module

This module (order code DO) can be fitted in slots 4, 5 and 6 with a maximum of three in any single controller. It contains two output channels. Each channel can be either 4-20mA control output, with 12 bit resolution, or a 24Vdc (20 to 30Vdc) transmitter supply. The module provides full 240Vac isolation.

This module may be used if:-

- extra analogue outputs are required to implement the control functionality
- extra precision and stability of control is desired. This because the module is power efficient and, therefore, does not cause significant temperature fluctuation inside the instrument
- extra power sources (fully isolated) are needed for passive current transmitters, active transducers requiring 20V to 30V source or I/Os of open collector type.

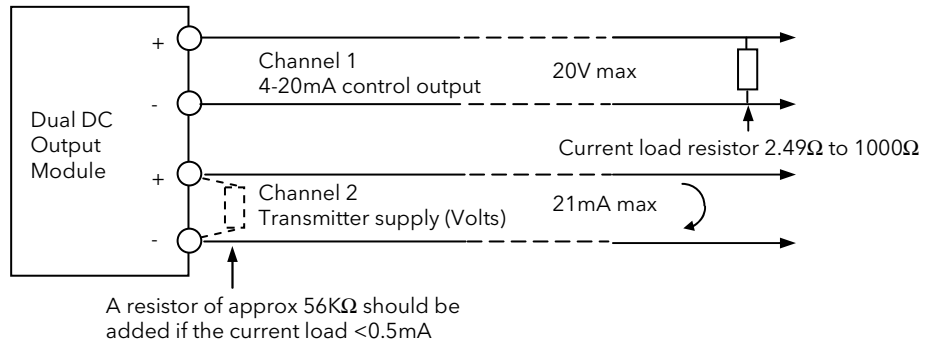
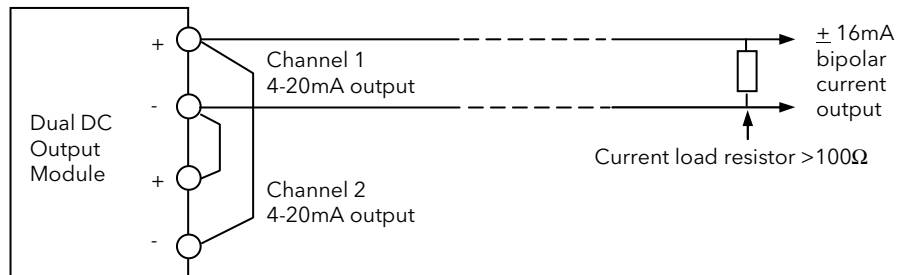


Figure 22-1: Ch1 & Ch2 Configured as Current Control & PSU



Channel 1 & 2 set up:-

Eng Val Lo	-100%	Alternatively one channel can be used with fixed 4mA while the other is varied between 4 and 20mA.
Eng Val Hi	100%	
Elec Lo	4mA	The polarity of the desired signal depends on which channel is fixed
Elect Hi	20mA	

Figure 22-2: Connections to Obtain a Bipolar (16mA) Current Output

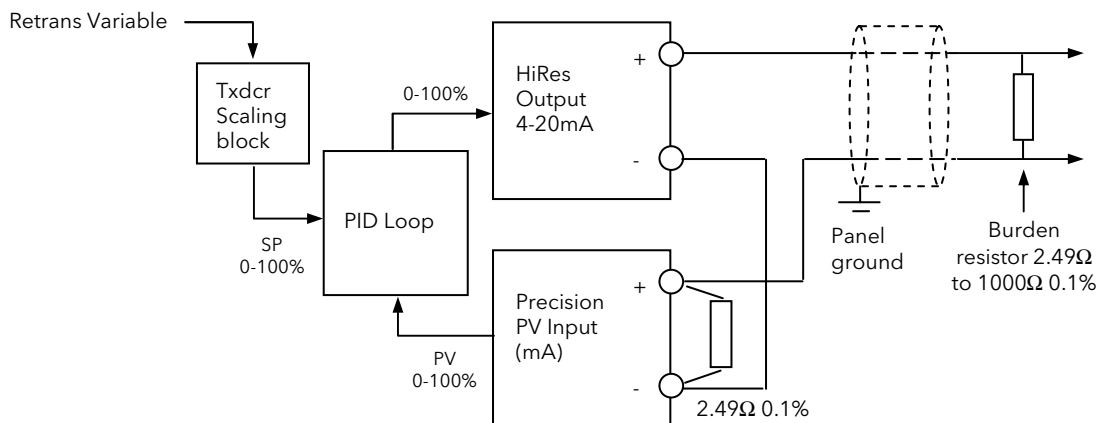
Table Number: 20.3.12.		This page allows you to set the parameters for a Dual DC Output module. This module can only be fitted in slots 4, 5 and 6.		MODULE IO (Module A(C) Page)	
Parameter Name	Parameter Description	Value	Default	Access Level	
This module has two outputs. Parameters are displayed under 'channel' (A) and 'channel' (C) Channel A and channel C can be 4-20mA or PSU outputs.					
Ident	Channel identification	DC Out		R/O	
Channel Type	Output type mA = analogue output Volts = transmitter PSU	mA Volts		Conf	
Wire Src	Source to which the channel is wired	Modbus address		Conf	
Electrical Lo	Electrical low input level	O/P range		L3. See output scaling	
Electrical Hi	Electrical high input level	O/P range			
Eng Value Lo	Low display reading	Disp. range			
Eng Value Hi	High display reading	Disp. range			
Electrical Val	The current electrical value of the output in operation mode	0 to 10.00V or 0 to 20mA		R/O L3	
<i>Module 1A</i> Val (can be a user defined name).	The current output value in operation mode.	±100.0% -ve values are not used		R/O L3	
Module Status	Module status	See Appendix D3		L3	
Channel Name	User defined name for the channel. Select from User Text page, section 5.2.6.		Default text	Conf	
Cal state	Allows the module to be calibrated	Idle Cal Low Confirm Go Now Trim O/P Accept Cal High Restore Factory Save	Idle	Conf	
Cal Trim	Output calibration trim Only appears when Cal State = Now Trim O/P			Conf	

22.3.13 High Resolution Retransmission Output

This module (order code HR) can be fitted in slots 4, 5 and 6 with a maximum of three in any single controller. It contains two output channels. The first channel provides a high resolution, 15 bit, 4-20mA or 0-10Vdc retransmission signal. The second provides 24Vdc (20 to 30Vdc) transmitter supply. The module provides full 240Vac isolation.

This unit has been designed for use as a conditioning circuit for complex passive sensors/transducers such as may be found in a carbon potential control system.

The high resolution is achieved in feedback mode using a PID control loop. The retransmission variable provides the setpoint for the PID loop. The output from the module provides the PV input to the loop which corrects for any variations in the output signal.



Precision PV Input set up:-		PID Loop set up	
Elec Lo	4mA	Proportional band (PB)	125%
Elect Hi	20mA	Integral time (Ti)	0.4sec
Filter time	0.2sec	Derivative time (Td)	Off

All the internal variables of the loop and their limits are set to 0 -100% range.

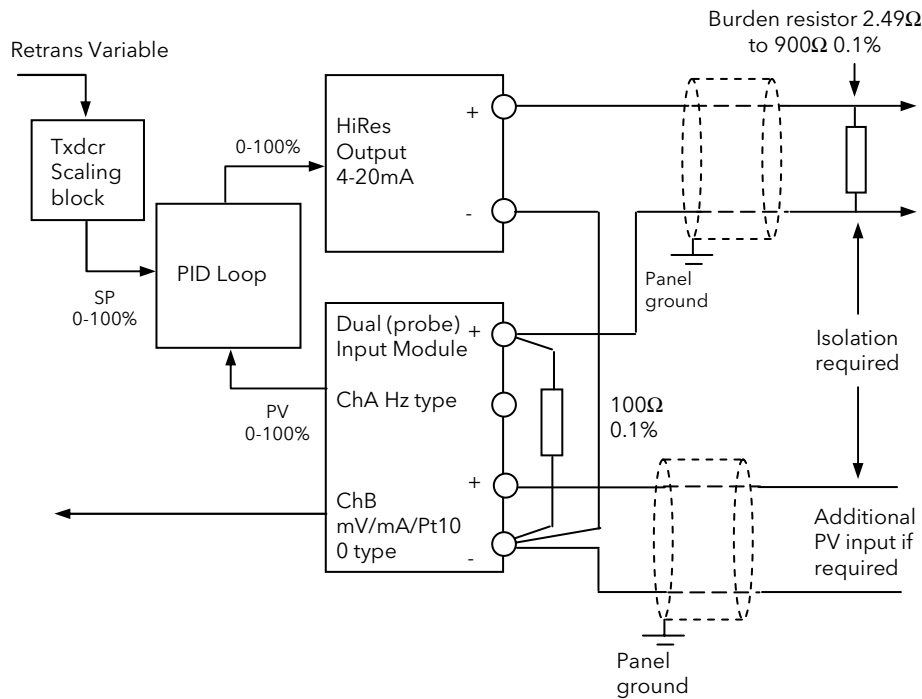
Figure 22-3: Precision 4-20mA Current Loop Retransmission (15bit) using a single precision PV input module.

Notes:

1. To guarantee that the 4-20mA range is fully covered the channel output is calibrated at 3.8mA (cal low) and 20.5mA (cal High).
2. To utilise the full potential for high accuracy/resolution extra care should be taken to ensure low levels of EM interference as follows:-
 - keep connecting cables away from power cables
 - ground 'Dig Common' of the controller to local panel ground
 - use shielded cables with the shield connected to local panel ground

Precise 4-20mA Current Loop Retransmission (14bit)

Using Dual (probe) module and a feedback loop with input from channel A



Channel A Input set up:-

Elec Lo	0.4V
Elec Hi	2V
Filter time	0.4sec

PID Loop set up

Proportional band (PB)	145%
Integral time (Ti)	0.6sec
Derivative time (Td)	Off

All the internal variables of the loop and their limits are set to 0 -100% range.



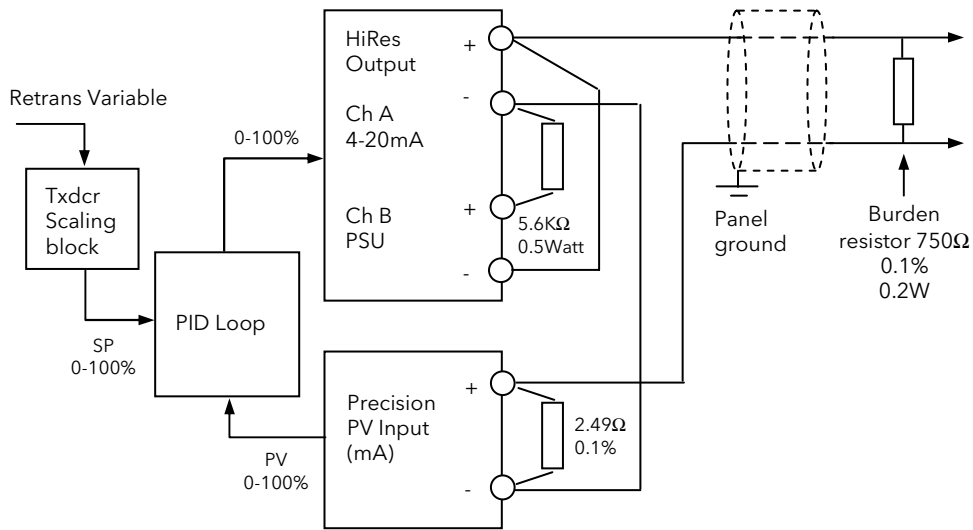
Channel C input and the retransmitted 4-20mA output must be connected together at the (-) terminal of the Dual (probe) input. The receiving instrument 4-20mA input and the other end of the channel C input should be isolated from each other. It is the installers responsibility to ensure the appropriate isolation when using the Dual (probe) module.

Notes:

- To guarantee that the 4-20mA range is fully covered the channel output is calibrated at 3.8mA (cal low) and 20.5mA (cal High).
- To utilise the full potential for high accuracy/resolution extra care should be taken to ensure low levels of EM interference as follows:-
 - keep connecting cables away from power cables
 - ground 'Dig Common' of the controller to local panel ground
 - use shielded cables with the shield connected to local panel ground

Precise 0-10V Voltage Retransmission (15bit)

Using a single precision PV input, PSU output and a feedback loop



Precision PV Input (mA) set up:-

Elec Lo	0mA
Elec Hi	13.333mA
Filter time	0.2sec

PID Loop set up

Proportional band (PB)	125%
Integral time (Ti)	0.4sec
Derivative time (Td)	Off

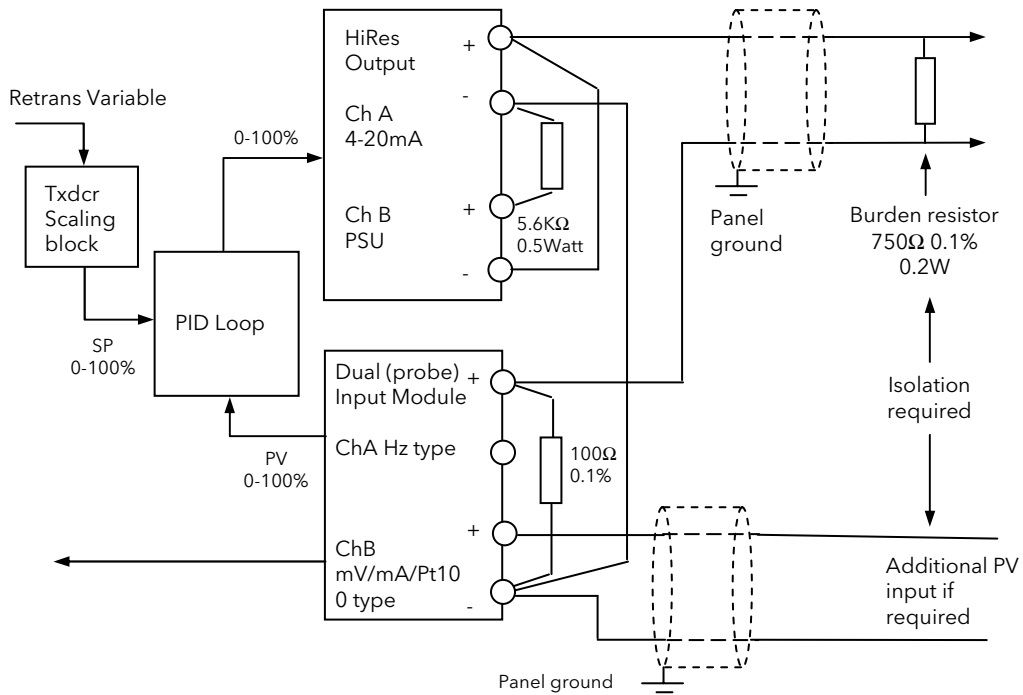
All the internal variables of the loop and their limits are set to 0 -100% range.

Notes:-

2. Range of the retransmitted voltage can be scaled by using different burden resistors:-
 - 150Ω will produce 0-2V range
 - 100Ω will produce 0-1.333V range
3. To guarantee that the 4-20mA range is fully covered the channel output is calibrated at 3.8mA (cal low) and 20.5mA (cal High).
4. To utilise the full potential for high accuracy/resolution extra care should be taken to ensure low levels of EM interference as follows:-
 - keep connecting cables away from power cables
 - ground 'Dig Common' of the controller to local panel ground
 - use shielded cables with the shield connected to local panel ground

Precise 0-10V Voltage Retransmission (14bit)

Using a Dual (probe) input, PSU output and a feedback loop with input from channel A.



Precision PV Input (mA) set up:-

Elec Lo	0V
Elect Hi	13.333V
Filter time	0.4sec

PID Loop set up

Proportional band (PB)	145%
Integral time (Ti)	0.6sec
Derivative time (Td)	Off

All the internal variables of the loop and their limits are set to 0 -100% range.



Channel C input and the retransmitted 4-20mA output must be connected together at the (-) terminal of the Dual (probe) input. The receiving instrument 4-20mA input and the other end of the channel C input should be isolated from each other. It is the installers responsibility to ensure the appropriate isolation when using the Dual (probe) module.

Notes on the previous page apply

Table Number: 20.3.13.		This page allows you to set the parameters for a High Resolution Output module. This module can only be fitted in slots 4, 5 and 6.		MODULE IO (Module 4(C) Page)	
Parameter Name	Parameter Description	Value	Default	Access Level	
This module has two outputs. Parameters are displayed under 'channel' (A) and 'channel' (C) Channel A can be 4-20mA output or transmitter PSU, channel C is the PSU.					
Ident	Channel identification	Hi Res Out		R/O	
Channel Type	Output type	mA (not Ch C) Volts		Conf	
Wire Src	Source to which the channel is wired	Modbus address		Conf	
Electrical Lo	Electrical low input level	O/P range		L3. See output scaling	
Electrical Hi	Electrical high input level	O/P range			
Eng Value Lo	Low display reading	Disp. range			
Eng Value Hi	High display reading	Disp. range			
Electrical Val	The current electrical value of the output in operation mode	0 to 10.00V or 0 to 20mA		R/O L3	
<i>Module 1A Val</i> (can be a user defined name).	The current output value in operation mode.	±100.0% -ve values are not used		R/O L3	
Module Status	Module status	See Appendix D3		L3	
Channel Name	User defined name for the channel. Select from User Text page, section 5.2.6.		Default text	Conf	
Cal state	Allows the module to be calibrated	Idle Cal Low Confirm Go Now Trim O/P Accept Cal High Restore Factory Save	Idle	Conf	
Cal Trim	Output calibration trim Only appears when Cal State = Now Trim O/P			Conf	

22.4 MODULE SCALING

The IO modules are scaled as already described in Chapter 19 for the fixed inputs and outputs. The procedures are repeated below:-

22.4.1 The PV Input

Scaling of the PV input applies to linear process inputs, eg linearised transducers, where it is necessary to match the displayed reading to the electrical input levels from the transducer. PV input scaling is not provided for direct thermocouple or RTD inputs.

Figure 20-4 shows an example of input scaling where an electrical input of 4-20mA requires the display to read 2.5 to 200.0 units.

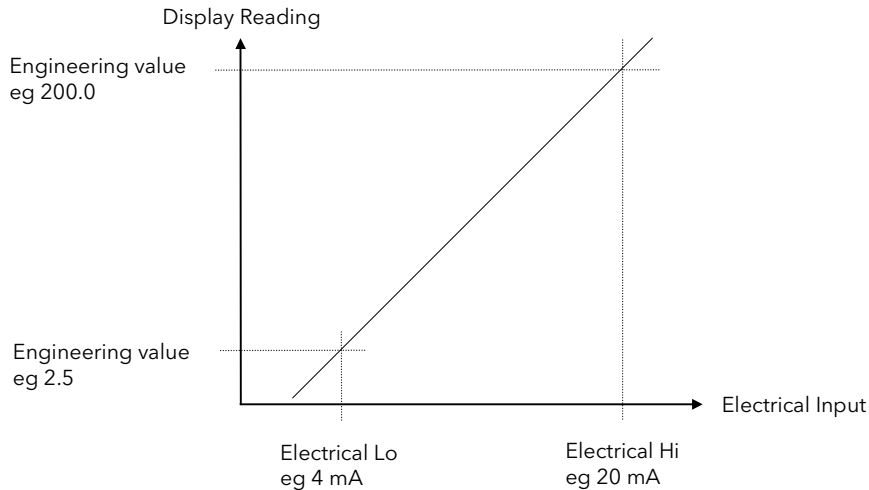


Figure 22-4: Input Scaling (Modules)

22.4.2 To Scale a Linear PV Input:-

Do This	This Is The Display You Should See	Additional Notes
1. From any display press as many times as necessary to select 'MODULE IO'		
2. Press or to choose the slot in which the PV Input module is fitted, e.g. 3A		
3. Press to scroll to 'Electrical Lo'		The next four parameters are only available if the 'Channel Type' = mV, mA, Volts, HZVolts Set this value to the lowest level of the input, eg 4mA. It may be necessary to set 'Electrical Hi' first since this limits the adjustment of 'Electrical Lo'.
4. Press or to set the value		
5. Press to scroll to 'Electrical Hi'		Set this value to the highest level of the input, eg 20mA.
6. Press or to set the value		
7. Press to scroll to 'Eng Val Lo'		Set up the displayed value (instrument minimum span) which corresponds to the Electrical Lo input, eg 2.50 The number of decimal places depends on the 'Resolution' set
8. Press or to set the value		
9. Press to scroll to 'Eng Val Hi'		Set up the displayed value (instrument maximum span) which corresponds to the Electrical Hi input, eg 200.00
10. Press or to set the value		

22.4.3 Output modules

If the output module is DC or if it is a relay, triac or logic used as time proportioning control, it can be scaled such that a lower and upper level of PID demand signal can limit the operation of the output value. This is shown in Figure 20-5 applied to a relay output or any time proportioning output..

By default, the relay will be fully off for 0% power demand, fully on for 100% power demand and equal on/off times at 50% power demand. You can change these limits to suit the process. It is important to note, however, that these limits are set to safe values for the process. For example, for a heating process it may be required to maintain a minimum level of temperature. This can be achieved by applying an offset at 0% power demand which will maintain the relay on for a period of time. Care must be taken to ensure that this minimum on period does not cause the process to overheat

These offsets can be made to parameters in the relevant Module IO pages.

If the output is DC the electrical low and electrical high parameters are analogue values and can be set as in the example given for DC Output Retransmission, section 20.4.5.

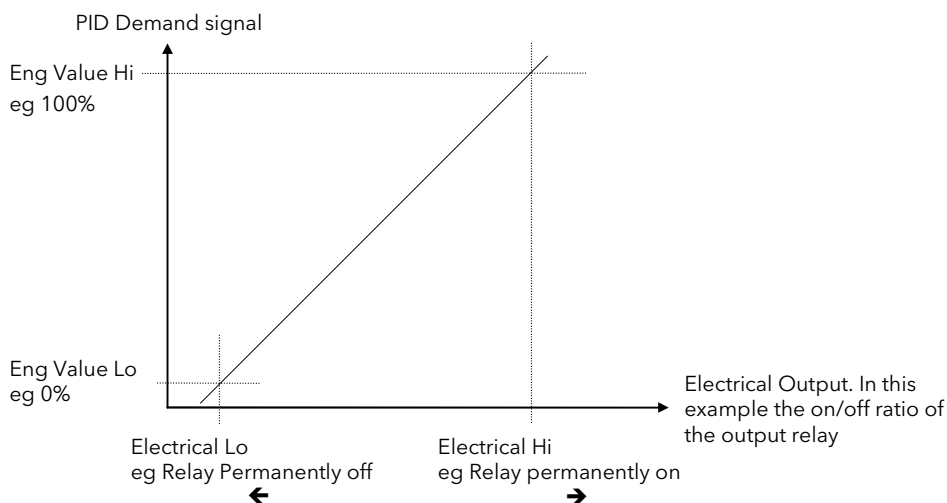











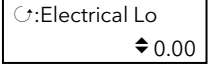



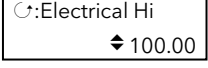







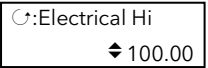


Figure 22-5: Time Proportioning Relay, Triac or Logic Output

22.4.4 To Scale A Control Output:-

Do This	This Is The Display You Should See	Additional Notes
1. From any display press  as many times as necessary to select ' MODULE IO ' 2. Press  or  to choose the slot in which a relay, triac or logic output is fitted		This procedure can also be done in Level 3.
3. Press  to show the first parameter in the list. This is ' Channel Type ' 4. Press  or  to choose the function of the relay		The choices are:- On/Off Time proportion Valve Raise Valve Lower
5. Press  to scroll to ' Electrical Lo ' 6. Press  or  to adjust the value		If the relay is wired to the PID output demand signal set this to a low value, normally 0. If it is set to a higher value the relay will remain on for a period of time even when the PID demand is zero. This parameter is limited by 'Electrical Hi' which may need to be adjusted first.
7. Press  to select ' Electrical Hi ' 8. Press  or  to adjust the value		If the relay is wired to the PID output demand signal set this to a high value, normally 100.
9. Press  to select ' Eng Value Lo ' 10. Press  or  to adjust the value		This is the value of the PID demand signal which will cause the relay to switch as set by 'Electrical Lo'
11. Press  to select ' Eng Value Hi ' 12. Press  or  to adjust the value		This is the value of the PID demand signal which will cause the relay to switch as set by 'Electrical Hi'

22.4.5 Retransmission Output

The retransmission output can be scaled so that the output value corresponds to range of the signal to be retransmitted.

Figure 20-6 shows an example where the retransmitted signal is PV or SP and an electrical output of 4-20mA represents 20.0 to 200.0 units.

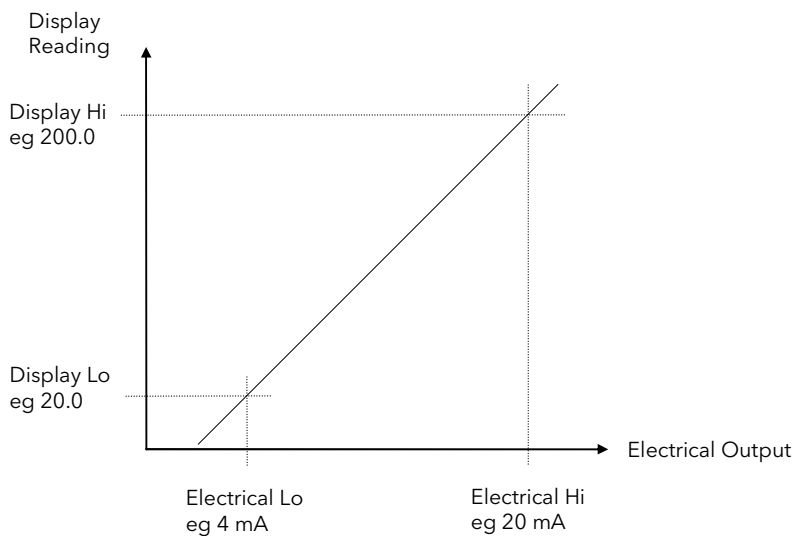


Figure 22-6: Scaling a Retransmission Output

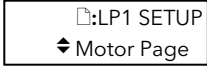



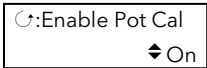












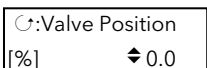





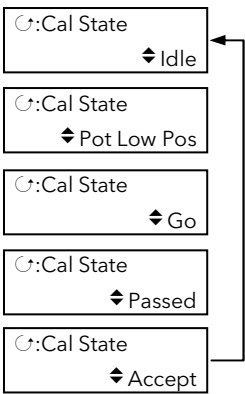


22.4.6 To Scale a Retransmission Output

Do This	This Is The Display You Should See	Additional Notes
1. From any display press as many times as necessary to select 'MODULE IO'		This procedure can also be done in Level 3.
2. Press or to select a slot in which a DC output is fitted		
3. Press to show the first parameter in the list. This is 'Channel Type'		
4. Press or to choose Volts or mA		
5. Press to scroll to 'Electrical Lo'		Using the example in Figure 20-3 set this value to 4mA This parameter is limited by 'Electrical Hi' which may need to be adjusted first.
6. Press or to adjust the value		
7. Press to select 'Electrical Hi'		
8. Press or to adjust 20mA		
9. Press to select 'Eng Value Lo'		The number of decimal places depends on the 'Resolution'
10. Press or to adjust to 20		
11. Press to select 'Eng Value Hi'		The retransmission signal of 4 - 20mA will correspond to a display reading of 20.00 to 200.00
12. Press or to adjust to 200		

22.4.7 To Scale the Potentiometer input

When using the controller in bounded valve position control mode, it is necessary to calibrate the feedback potentiometer to correctly read the position of the valve. The value of the potentiometer input is read by the parameter 'Module xA Val', where x is the number of the slot in which the Pot Input module is fitted.

To calibrate the potentiometer input, it is necessary to carry out this procedure in access level 3:-

Do This	This Is The Display You Should See	Additional Notes
Enable Potentiometer Calibration		
1. From the relevant LOOP SETUP page select ' Motor Page '		<i>LP1</i> is a user definable name and may be different in your controller
2. Press  to scroll to ' Enable Pot Cal ' 3. Press  or  to ' On '		This parameter is only displayed when the 'Pot IP Src', <i>LP1</i> SETUP (Wiring Page), is wired and 'Control Type'. <i>LP1</i> SETUP (Options Page), is set to VP or VPB
Select the slot in which the Pot Input Module is fitted		
1. Press  as many times as necessary to select ' MODULE IO ' 2. Press  or  to select the module in which the potentiometer input is fitted		This example assumes the Pot Input Module is fitted in slot 5
3. Press  to scroll to the required parameters, for example ' Eng Val Lo ' or ' Eng Val Hi '.		' Eng Val Lo ' and ' Eng Val Hi ' will normally be set to 0 and 100 respectively to represent a fully closed to fully open position of the valve These parameters do not limit the travel of the valve but provide an indication of the pot position
Calibrate the Potentiometer Minimum Position		
1. Press  to scroll to ' Cal State '		
2. Press  to return to an Overview page		This is an example of an Overview page. It can only be accessed in level 3
3. Press  to scroll to ' Valve Position ' 4. Press  to close the valve		
5. Press  to return to ' Cal State ' 6. Press  or  to select ' Pot Low Pos ' 7. To confirm, press  or  to select ' Go '. 8. (You can also select ' Abort ' at this point)		To calibrate follow the instructions on the display. When the controller is calibrating the message ' Doing Fine Cal ' appears. When the controller has finished the message ' Passed ' appears. Press  or  to ' Accept '. After approx 3 seconds the display will revert to ' Idle ' completing the procedure. You can also ' Abort ' at this stage.
Calibrate the Potentiometer Maximum Position		
Repeat the above steps to adjust the valve fully open by selecting ' Pot Hi Pos '		



The Potentiometer Input Module can also be used simply so that the resistance value represents an engineering value, such as 35 to 780 mm or 0-1000 Ω . The parameters '**Eng Val Lo**' and '**Eng Val Hi**' are then set to these values.

The procedure to calibrate for these readings is the same as above but, of course, it is not necessary to revert to the Overview display since the potentiometer can be adjusted manually.

When the pot position parameter is highlighted, the units are displayed in the upper right of the display banner.

The units and resolution will have been set in configuration level.

An Out of Range signal will be displayed if the pot measurements lay outside the calibrated range.

22.5 MODULE IO WIRING EXAMPLES

22.5.1 To Configure Module 1 Channel A to Run a Program

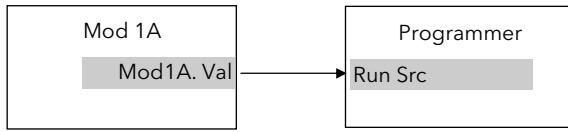


Figure 22-7: External Run/Hold Switch

This example assumes a Triple Logic module fitted in module slot 1. No configuration of the Module 1A function block is required but the output of the block must be wired to the Run Source in the Programmer block.

22.5.1.1 Implementation

- In PROGRAM EDIT/Wiring Page
 - set 'Run Src' = 04148:Mod1A.Val
 - This connects the output of module 1A to the Run Source wire in the Programmer block.

22.5.2 To Operate a Relay from a Digital Input

This example assumes that a Relay Module is fitted in module slot 2, and it is required to operate when Digital Input 1 is true.

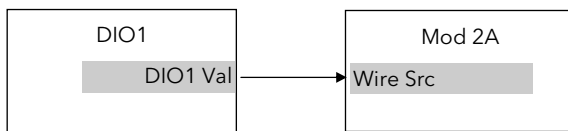


Figure 22-8: To Operate a Relay from a Digital Input

22.5.2.1 Implementation

- In STANDARD IO/Dig IO1 Page
 - set 'Channel Type' = Digital Input
 - This configures DIO1 to be digital input
- In MODULE IO/Module 2 A Page
 - set 'Channel Type' = On/Off
 - set 'Wire Src' = 05402:DIO1.Val
 - This configures Module 2A to On/Off relay and connects DIO1 to operate this relay.

22.5.3 Zirconia Probe Impedance Measurement

The impedance of Zirconia probes can increase with age. The 2604 controller can be used to monitor this impedance using the 'Sensor Break Value' parameter. An alarm on this parameter can be provided if required.

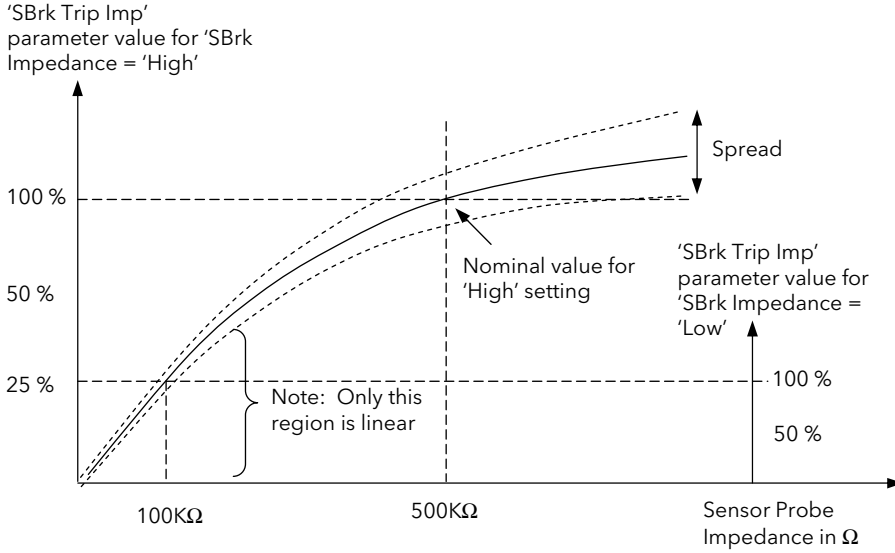
The controller continuously monitors the impedance of a transducer or sensor connected to any analogue input. This impedance, expressed as a percentage of the impedance which causes the sensor break flag to trip, is a parameter called 'SBrk Trip Imp' and is available in the parameter lists associated with both Standard and Module inputs of an analogue nature.

The table below shows the typical impedance which causes sensor break to trip for HZVolts input and High and Low 'SBrk Impedance' parameter settings.

HZ Volts (-1.5 to 2V) (applies to Standard PV Input, PV Input module and Dual PV Input module)	
SBrk Impedance - High	~ 500KΩ
SBrk Impedance - Low	~ 100KΩ

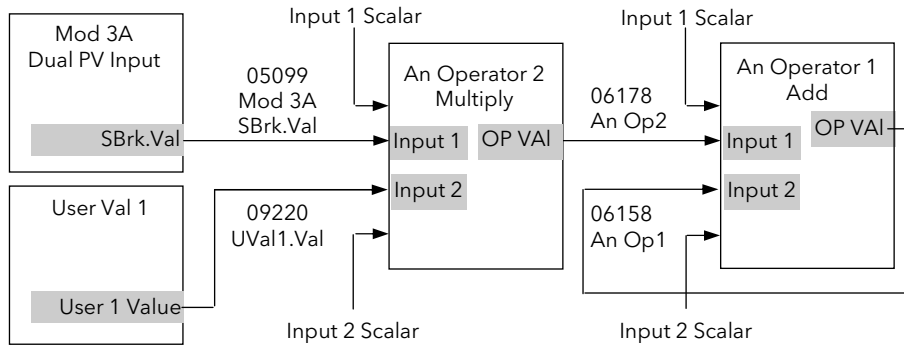
The graph below shows the approximate relationship between the actual sensor impedance, in ohms, and the measured 'SBrk Trip Imp' parameter, in %, for HZ Volts input type using Standard PV Input, PV Input Module and Dual PV Input module.

Please note that the relationship is not linear, particularly above 30% of the parameter value on High setting. Also that the 'SBrk' reading has a large manufacturing spread and is not factory calibrated. It is recommended, therefore, that the 'SBrk Trip Imp' is calibrated against a known resistor in the range 50 to 100kΩ.



22.5.3.1 Implementation

This example assumes the Zirconia inputs is connected to the Dual PV Input module, Mod 3. Analogue Operator 2 acts as a scalar to convert % to a calibrated value of impedance. User Value 1 is used as a convenient way to calibrate the sensor break value against a known resistor. Since the signal can be noisy, Analogue Operator 1 acts as a simple filter.



- In MODULE IO/Module 3A (or 6A) Page set 'SBrk Impedance' = High
- In ANALOGUE OPERS/An 2 Page
 - set Operation = Multiply
 - set Input 1 Src = 05099 (Sensor break value)
 - set Input 1 scalar = 1.0
 - set Input 2 Src = 09220 (User value 1 output)
 - set Input 1 scalar = 1.0
- In ANALOGUE OPERS/An 1 Page
 - set Operation = Add
 - set Input 1 Src = 06178 (Analogue Operator 2 Output value)
 - set Input 1 scalar = 0.01
 - set Input 2 Src = 06158 (Analogue Operator 1 Output value)
 - set Input 1 scalar = 0.99

These settings of input scalar will ensure that the Output Value reaches the same value as Input 1 Value

22.5.3.2 Calibration

- Connect a known value of resistor (between 50 and 100K Ω) in place of the probe
- Adjust User 1 Value so that Analogue Operator 2 Output Value reads the value of the resistor
- The output from Analogue Operator 2 should ramp to the same value. This value can be promoted to a User Screen or used to provide an alarm.

23.CHAPTER 21 TRANSDUCER SCALING

23.1 WHAT IS TRANSDUCER SCALING?

Transducer scaling is a software function block which provides a method of offsetting the calibration of the controller input when compared to a known input source. Transducer scaling is often performed as a routine operation on a machine to take out system errors. In the case of a load cell, for example, it may be necessary to zero the scale when a load is removed.

Transducer scaling can be applied to any input or derived input, i.e. the PV Input, Analogue Input or Modules 1, 3, 4, 5, or 6. In practice, however, it is unlikely that transducer scaling would be required on every input and so the 2604 controller includes three transducer calibration function scaling blocks. These can be wired in configuration level to any three of the above inputs.

Four types of calibration are explained in this chapter:-

1. Shunt Calibration
2. Load Cell Calibration
3. Comparison Calibration
4. Auto-tare

23.2 SHUNT CALIBRATION

Shunt calibration is so called since it refers to switching a calibration resistor across one arm of the four wire measurement bridge in a strain gauge transducer. It also requires the use of a Transducer Power Supply.

The strain gauge transducer is calibrated as follows:

1. Remove any load from the transducer to establish a zero reference.
2. Enter 'Scale Low' and 'Scale High' values which are normally set at 0% and 80% of the span of the transducer.
3. Start the procedure using the low point calibration parameter 'Start Pnt1 Cal', or a digital input wired to this parameter.

The controller will automatically perform the following sequence:

1. Disconnect the shunt resistor
2. Calculate the low point calibration value by continuously averaging two lots of 50 measurements of the input until stable readings are obtained
3. Connect the shunt resistor
4. Calculate the high point calibration value by averaging two lots of 50 measurements of the input

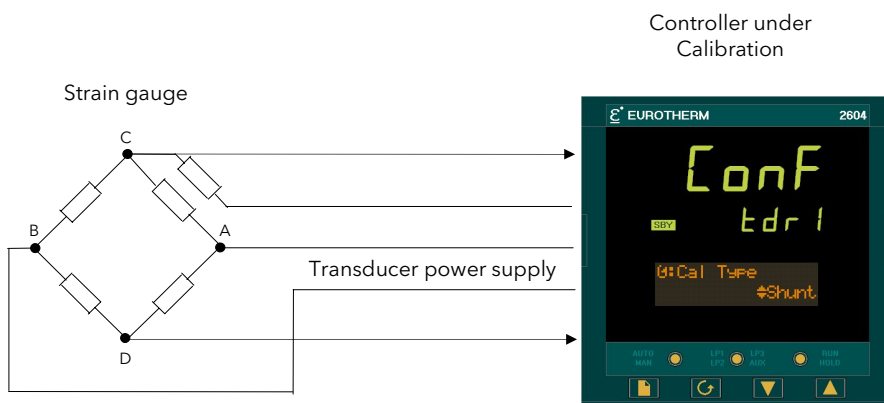

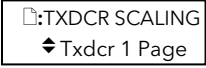



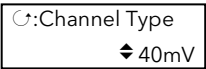





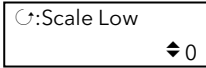



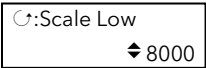



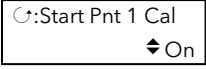


Figure 23-1: Strain Gauge Calibration

23.2.1 To Calibrate a Strain Gauge Bridge Transducer

The controller must have been configured for Cal Type = Shunt, and the transducer connected as shown in Appendix F using the 'Transducer Power Supply'. Then:-

Do This	This Is The Display You Should See	Additional Notes
It is first necessary to enable calibration as follows:-		
1. From any display press  as many times as necessary to select ' TXDCR SCALING '		The choices are : <i>Txdcr 1</i> <i>Txdcr 2</i> <i>Txdcr 3</i>
2. Press  or  to choose ' Txdcr 1 (or 2 or 3) Page '		This text can be user defined
3. Press  to show the first parameter in the page, this is Enable Cal		This parameter remains 'On' once it has been set. It requires to be switched 'Off' manually.
4. Press  or  to On		It may be wired to an external digital input source such as a key switch

Set the strain gauge bridge to its 'zeroed' condition

1. Press  as many times as necessary to scroll to Scale Low		This will normally be zero
2. Press  or  to enter the low end calibration value		
3. Press  to scroll to Scale High		In this example a value of 8000 is chosen which may represent 80% of the 0 -10,000psi range of a pressure transducer.
4. Press  or  to enter the high end calibration value		
5. Press  to scroll to Start Pnt 1 Cal		This parameter can be configured to be initiated from a digital input and wired, for example, to an external switch.
6. Press  or  to enter On		An example of this wiring is given at the end of this chapter

 Tip: To backscroll hold down  and press 

The controller automatically performs the procedure described in Section 21-2. During this time the **Cal Active** parameter will change to **On**. When this parameter value changes back to **Off** the calibration is complete.

The **Shunt State** parameter will also change during the procedure to show when it is being connected (On = connected, Off = disconnected).

Note:-

It is possible to start the calibration procedure before the system has settled at a stable value. The controller continuously takes blocks of 50 samples. When the average value between two consecutive blocks is within the '**Threshold Value**' the controller will then calibrate. The Threshold Value defaults to 0.5 but can be adjusted in configuration level. If the readings are not stable within this period the controller will abort the calibration.

23.3 LOAD CELL CALIBRATION

A load cell with V, mV or mA output may be connected to the PV Input, Analogue Input or Modules 1, 3, 4, 5, 6 supplied as analogue inputs. The wiring connections are shown in the User Guide Chapter 2

The load cell is calibrated as follows:

1. Remove any load and start the procedure using the low point calibration parameter 'Start Pnt1 Cal', or a digital input wired to this parameter. The controller will calculate the low calibration point
2. Place a reference weight on the load cell and turn on the high point calibration parameter 'Start Pnt2 Cal', or a digital input wired to this parameter. The controller will then calculate the high calibration point.

Note:-

If 'Start Pnt1 Cal' = 'On', 'Start Pnt2 Cal' cannot be turned to 'On'.

If 'Start Pnt2 Cal' = 'On', 'Start Pnt1 Cal' cannot be turned to 'On'.

Either must complete before the other can be set to 'On'.

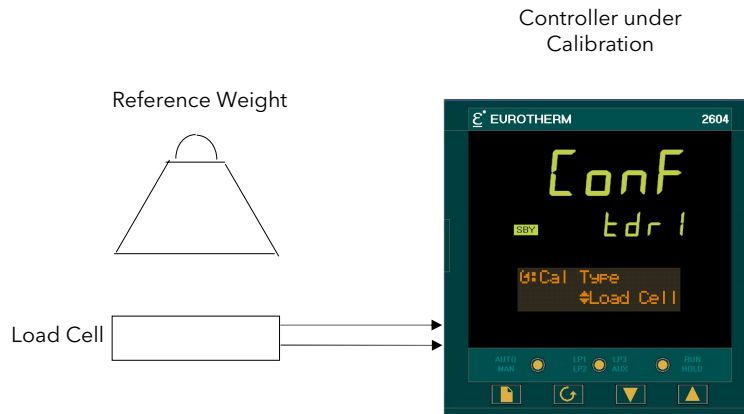

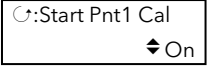



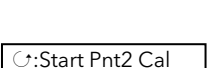




Figure 23-2: Load Cell Calibration

23.3.1 To Calibrate a Load Cell

The controller must have been configured for Cal Type = Load Cell, and the transducer connected as shown in the Appendix F. Then:-

Do This	This Is The Display You Should See	Additional Notes
Enable calibration as described in section 21.2.1.		
Then set the load cell to its 'zeroed' condition		
1. Press  as many times as necessary to scroll to 'Start Pnt1 Cal'		This parameter can be configured so that it is activated from a digital input and wired, for example, to an external switch.
2. Press  or  to 'On'		An example of this wiring is given at the end of this chapter During the time taken for the controller to calculate the low point calibration value, the Cal Active parameter will be On .
When the Calibration Low procedure is complete, place the reference load on the load cell		
3. Press  to scroll to Start Pnt2 Cal		It can be configured to be initiated from a digital input and wired, for example, to an external switch.
4. Press  or  to On		An example of this wiring is given at the end of this chapter

Note:-

'Scale High' is the high calibration point and 'Scale Low' is the low calibration point. These should be set to the range over which calibration is required. 'Threshold Value' applies as in the previous section.

23.4 COMPARISON CALIBRATION

Comparison calibration is most appropriate when calibrating the controller against a second reference instrument.

In this case the process calibration points are not entered ahead of performing the calibration. The input may be set to any value and, when the system is stable, a reading is taken from the reference measurement device and entered into the controller. The controller stores both this new target value and the actual reading taken from its input.

The process is repeated at a different value, with the controller storing both the new target value and the reading taken from its input.

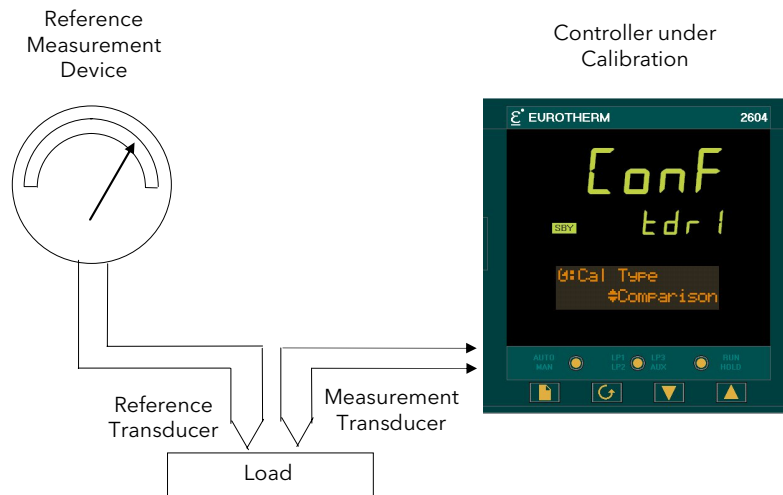

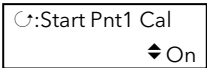



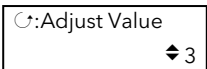


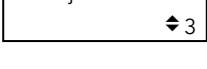



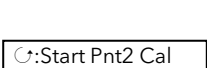



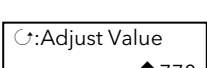


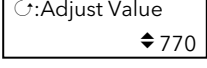




Figure 23-3: Comparison Calibration

23.4.1 To Calibrate a Controller Against a Second Reference

The controller must have been configured for Cal Type = Comparison, and the transducer connected as shown in the Appendix F. Then:-

Do This	This Is The Display You Should See	Additional Notes
Enable calibration as described in section 21.2.1.		
Then allow the process to settle at the low calibration point		
1. Press  as many times as necessary to scroll to 'Start Pnt1 Cal'		This parameter can be configured to be activated from a digital input and wired, for example, to an external switch.
2. Press  or  to 'On'		An example of this wiring is given at the end of this chapter
3. Press  as many times as necessary to scroll to 'Adjust Value'		The confirm message does not appear unless 'Adjust Value' is changed.
4. Press  or  to enter the value indicated on the reference instrument		If the displayed value is acceptable change it momentarily then back to the value to step to the next stage.
5. Press  to confirm or  to cancel as instructed		On confirm the current input value is stored as 'Input Low' and the value entered by the user is stored in the 'Scale Low' parameter.
Allow the Process to settle at the high calibration point		
6. Press  to 'Start Pnt2 Cal'		This parameter can be initiated from a digital input and wired, for example, to an external switch.
7. Press  or  to 'On'		An example of this wiring is given at the end of this chapter
8. Press  as many times as necessary to scroll to 'Adjust Value'		The confirm message does not appear unless 'Adjust Value' is changed.
9. Press  or  to enter the value indicated on the reference instrument		If the displayed value is acceptable change it momentarily then back to the value to step to the next stage.
10. Press  to confirm or  to cancel as instructed		On confirm the current input value is stored as 'Input High' and the value entered by the user is stored in the 'Scale High' parameter.

It is possible to perform either low or high points in isolation, or to calibrate both points consecutively as described above.










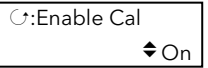
23.5 AUTO-TARE CALIBRATION

The auto-tare function is used, for example, when it is required to weigh the contents of a container but not the container itself.

The procedure is to place the empty container on the weigh bridge and 'zero' the controller. Since it is likely that following containers may have different tare weights the auto-tare feature is always available in the controller at access level 1.




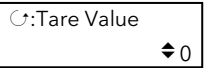




23.5.1 To Use the Auto-Tare Feature

Firstly, enable calibration as follows:-

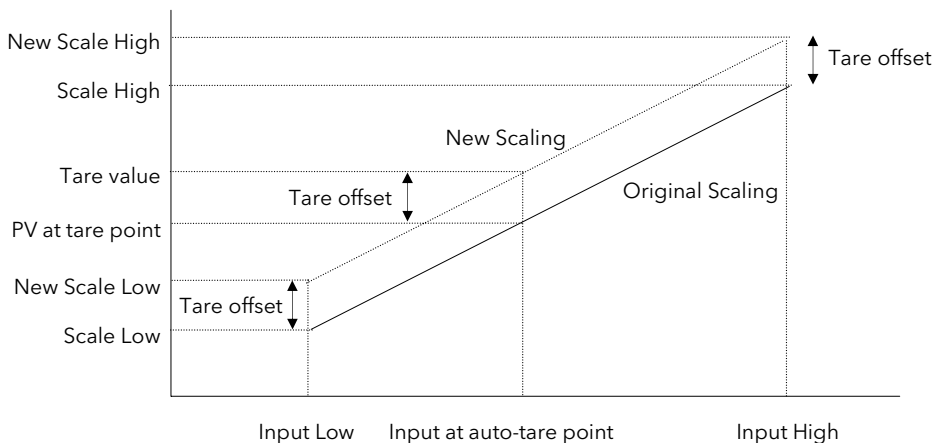
Do This	This Is The Display You Should See	Additional Notes
1. From any display press  as many times as necessary to access the page header menu 2. Press  or  to select 'TXDCR SCALING' 3. Press  or  to select 'Txdcr 1' (or 2 or 3)		The choices are : Txdcr 1 Txdcr 2 Txdcr 3 This can be user defined text
4. Press  to select Enable Cal 5. Press  or  to On (if necessary)		This parameter remains 'On' once it has been set. It requires to be switched 'Off' manually. It may be wired to an external digital input source such as a key switch.

The auto-tare calibration is then performed as follows:-

1. Set the equipment at the normal tare point, eg place the empty container on the weigh bridge

1. Press  to 'Tare Value' 2. Press  or  to enter the required value		This will normally be zero. When once set it will only be necessary to access this parameter again if a new tare value is required.
3. Press  as many times as necessary to scroll to 'Start Tare' 4. Press  or  to 'On'		This parameter can be initiated from a digital input and wired, for example, to an external switch. An example of this wiring is given at the end of this chapter.

The effect of auto-tare is to introduce a DC bias to the measurement, as shown in Figure 21-4 below.



Note:- A Tare calibration will change the values of 'Scale High' and 'Scale Low'.

Figure 23-4: Effect of Auto-Tare

23.6 TRANSDUCER SCALING PARAMETERS

The parameters listed in the table below allow you to soft wire to sources within the controller to provide, for example, operation of calibration procedure via external switches.

23.6.1 Transducer Scaling Parameter Table

Table Number: 21.6.1.		This page shows the Transducer Scaling parameters.		TXDCR SCALING (<i>Txdcr 1</i>)	
Parameter Name	Parameter Description	Value	Default	Access Level	
Cal Type	Type of calibration	Off Shunt Load Cell Comparison	Off	Conf	
Input Src	Pre-scaled value source	Modbus Address	None	Conf	
Enable Cal Src	Enable calibration source			Conf	
Clear Cal Src	Clear calibration source			Conf	
Start Pnt 1 Src	Start calibration point 1 source			Conf	
Start Pnt 2 Src	Start calibration point 2 source			Conf	
Start Tare S	Start auto tare calibration source			Conf	
Range Min	Minimum scale value			Conf	
Range Max	Maximum scale value			Conf	
Txdcr Name	Transducer name	From User Text	Default Text	Conf	
Enable Cal ⁽¹⁾	Enable calibration	Off On	Off	L3	
Start Tare ⁽²⁾	Start auto-tare calibration	Off On	Off	L1	
Start Pnt1 Cal ⁽³⁾	Start the calibration at point 1, normally the low point	Off On	Off	L1	
Start Pnt2 Cal ⁽⁴⁾	Start the calibration at point 2, normally the high point	Off On	Off	L1	
Clear Cal ⁽⁵⁾	Clear previous calibration values	Off On	Off	L3	
Tare Value	Sets the value that the controller will read after an auto-tare calibration	Display range		L3	
Input Low	Sets the scaling input low point			L3	
Input High	Sets the scaling input high point			L3	
Scale Low	Sets the scaling output low point			L3	
Scale High	Sets the scaling output high point			L3	
Threshold Val ⁽⁶⁾	The allowed difference between two consecutive averages during calibration	0 - 99.999 mins		L3	
Shunt State ⁽⁷⁾	Indicates that the shunt resistor is connected or not	Off On		L3 R/O	
Cal Active	Indicates calibration in progress	Off On		L3 R/O	
Input Value	Pre-scaled input value	-100 to 100	0	L1	
Scaled Value	Output from the scaling block.			R/O	
Adjust Value	Sets the value read by the reference source in comparison calibration only			L1	
OP Status	Output status based on input status and scaled PV	Good Bad		R/O	

23.6.2 Parameter Notes

1. Enable Cal This may be wired to a digital input for an external switch. If not wired, then the value may be changed.
When enabled the transducer parameters may be altered as described in the previous sections. When the parameter has been turned On it will remain on until turned off manually even if the controller is powered cycled.
2. Start Tare This may be wired to a digital input for an external switch. If not wired, then the value may be changed.
3. Start Pnt1 Cal This may be wired to a digital input for an external switch. If not wired, then the value may be changed.
It starts the calibration procedure for:
 1. Shunt Calibration
 2. The low point for Load Cell Calibration
 3. The low point for Comparison Calibration
4. Start Pnt2 Cal This may be wired to a digital input for an external switch. If not wired, then the value may be changed.
It starts the calibration procedure for:
 1. The high point for Load Cell Calibration
 2. The high point for Comparison Calibration
5. Clear Cal This may be wired to a digital input for an external switch. If not wired, then the value may be changed.
When enabled the input will reset to default values. A new calibration will overwrite the previous calibration values if Clear Cal is not enabled between calibrations.
6. Threshold Val The input needs to settle within a range which has been set in configuration level. The threshold value sets the required settling time for shunt, load cell and auto-tare calibration.
7. Shunt This parameter is an output from the function block which can be wired to a transducer scale module to close the shunt circuit and introduce the calibration resistor. It may be used in copy and paste wiring.

24.CHAPTER 22 IO EXPANDER

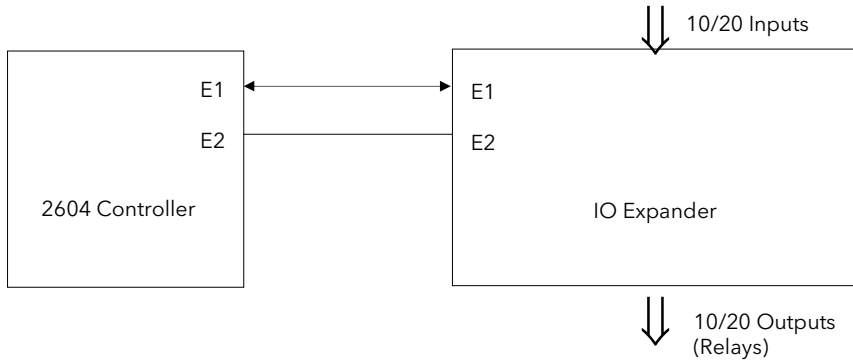
24.1 WHAT IS IO EXPANDER?

The IO Expander is an external unit which can be used in conjunction with the 2604 controller to allow the number of digital IO points to be increased. There are two versions:-

1. 10 Inputs and 10 Outputs
2. 20 Inputs and 20 Outputs

Each input is fully isolated and voltage or current driven. Each output is also fully isolated consisting of four changeover contacts and six normally open contacts in the 10 IO version and four changeover and sixteen normally open contacts in the 20 IO version.

Data transfer is performed serially via a two wire interface as shown in Figure 22-1.



E1 and E2 are the terminal numbers on both Controller and IO Expander. It is recommended that a cable length of 10 metres is not exceeded, however, no shielding or twisted pair cable is required.

Figure 24-1: IO Expander Data Transfer

Wiring connections and further details of the IO Expander are given in the IO Expander Handbook, Part No. HA026893.

When this unit is connected to the controller it is necessary to set up parameters to determine its operation. These parameters can be set up in Operation Level 3 and are repeated here for information.

The IO Expander is enabled in INSTRUMENT/Options Page, see Chapter 5.

24.2 TO CONFIGURE IO EXPANDER









Do This	This Is The Display You Should See	Additional Notes
1. From any display press as many times as necessary to select ' IO EXPANDER '		
2. Press to show the parameter list. This is ' Expander Type '		The choices are:- None 10 in 10 out 20 in 20 out
3. Press or to select the expander type		
4. Press to select ' OP 1 Src '		Parameter ' OP 1 Src ' has been connected to the ' Totaliser 1 Alarm Output '.
5. Press or to change the value or state		The IO Expander output 1 will operate when Totaliser 1 alarm output is exceeded.

Remaining parameters in the Analogue Operators list are accessed and adjusted in the same way.

The list of parameters available is shown in the following table



24.2.1 IO Expander parameters

Table Number: 22.2.1		This page allows you to configure the IO Expander.			IO EXPANDER
Parameter Name	Parameter Description	Value	Default	Access Level	
Expander Type	Expander type	None 10 in 10 out 20 in 20 out	None	Conf	
OP 1 Src	Output 1 source Source of the signal to operate relay 1 in the IO Expander.	Modbus address		Conf	
The above parameter is repeated for 10 or 20 outputs available in the IO Expander					
Status	IO Expander status	Good Bad		L1 R/O	
In Stat 1-10	Status of the first 10 digital inputs □□□□□□□□□□ to ■■■■■■■■■■	= Off ■ = On		L1 R/O	
In Stat 11-20	Status of the second 10 digital inputs □□□□□□□□□□ to ■■■■■■■■■■	= Off ■ = On		L1 R/O	
OP Stat 21-30	Status of the first 10 digital outputs. Press  to select outputs in turn. The flashing underlined output can be changed using  buttons.  □□□□□□□□□□ to  ■■■■■■■■■■	= Off ■ = On		L1	
OP Inv 1-10	To change the sense of the first 10 outputs.	= direct ■ = Inverted		L3	
Out Stat 31-40	Status of the second 10 digital outputs. Press  to select outputs in turn. The flashing underlined output can be changed using  buttons.  □□□□□□□□□□ to  ■■■■■■■■■■	= Off ■ = On		L1	
OP Inv 31-40	To change the sense of the second 10 outputs.	= direct ■ = Inverted		L3	

25.CHAPTER 23 DIAGNOSTICS

25.1 WHAT IS DIAGNOSTICS?

Diagnostics are displayed in Access Level 3 and Configuration level, and provide information on the internal state of the controller. The parameters are intended for use in advanced fault finding situations. Up to eight error messages can be listed and each error message displays a message showing the state of the controller. The error messages are shown in Note 1.

The diagnostic parameters are listed below:-

25.1.1 Diagnostics parameters

Table Number: 23.1.1		This page allows you to inspect diagnostic information			DIAGNOSTICS	
Parameter Name	Parameter Description	Value	Default	Access Level		
Error Count	Number of errors recorded			R/O		
Error 1	Historical errors where 1 is the most recent	See Note 1		R/O		
Error 2				R/O		
Error 3				R/O		
Error 4				R/O		
Error 5				R/O		
Error 6				R/O		
Error 7				R/O		
Error 8				R/O		
Clear Err Log?	Error log reset	No / Yes	No	Conf		
CPU % Free	A measure of the loading on the CPU			R/O		
Con Task Ticks	A measure of the activity of the algorithm			R/O		
UI Task 1 Ticks				R/O		
UI Task 2 Ticks				R/O		
Power FF	Power feedback. Measures the supply voltage to the controller			R/O		
Power Failures	A count of the number of power failures			R/O		

Note 1.

Possible error messages:-

- | | |
|---|----------------------------|
| OK | SPI Locked |
| Bad Ident | SPI Queue Full |
| Bad Fact Cal | HighP Lockout |
| Module Changed | Pro Mem Full |
| DFC1 Error, DFC2 Error, DFC3 Error | Invalid Seg |
| Module N/A | Program Full |
| CBC Comms Error | Invalid Prog |
| Cal Store Error | Bad Logic 1 to Bad Logic 7 |
| CBC Cal Error | CPU Add Err |
| Bad PV Input | Calc CRC Err |
| Bad Mod3 Input, Bad Mod4 Input, Bad Mod6 Input, | Bad Cal Restore |
| Bad An Input | Bad Cust Lin |
| Bad NVOL Check | Bad Instruct |
| Bad X Board | Bad Slot Instr |
| Bad Res Ident | DMA Addr Err |
| Bad SPI SemRel | Reserved Int |
| Bad CW EETrans | Undefined Int |
| Bad Prog Data | SPC Init Err |
| Bad Prog Csum | H Rx Timeout |
| SegPool Over | J Rx Timeout |

26.CHAPTER 24 CALIBRATION

The 2604 controller is calibrated in three ways. These are:-

1. **Factory Calibration.** The controller is calibrated to very high accuracy during manufacture and the calibration values are permanently stored within the controller. Factory calibration is not available to the user, but it is always possible to revert to the factory values if required.
2. **Transducer Scaling.** This is described in Chapter 21. Transducer scaling allows offsets to be entered to compensate for errors or differences in the process measurement system.
3. **User Calibration.** This allows the instrument to be calibrated against a certified field calibration source. This chapter describes User Calibration.

26.1 USER CALIBRATION

The following inputs can be calibrated:

1. **PV Input.** This is the fixed PV input on terminals VH, V1, V+, V-. The PV Input can be configured for Thermocouple, Platinum Resistance Thermometer (RTD), Pyrometer, mV, Volt, High Impedance Input Volts or mA inputs. Pyrometer and mA ranges are included in the mV range. Thermocouple calibration involves calibrating the temperature offset of the CJC sensor only. Other aspects of thermocouple calibration are also included in mV calibration.
2. **Analogue Input.** This is the fixed input on terminals BA, BB, BC, and is intended for volt or current sources.
3. **Analogue I/O Modules.** These are inputs which can be connected to terminals A, B, C, D of the module I/O. Any input type listed above can be connected to these modules.

See also the 'Installation' chapter in the User Guide for details on terminal connections.

26.2 PRECAUTIONS

Before starting any calibration procedure the following precautions should be taken:-

1. When calibrating mV inputs make sure that the calibrating source outputs less than 250mV before connecting it to the mV terminals. If accidentally a large potential is applied (even for less than 1 second), then at least one hour should elapse before commencing the calibration.
2. RTD calibration is incomplete without mV calibration. A strict procedure, presented in section 24.3.5. must be followed to avoid calibration errors being up to an order of magnitude greater than that specified for this input. This particularly concerns the linearity specification.

A pre-wired jig built using a spare instrument sleeve may help to speed up the calibration procedure especially if a number of instruments are to be calibrated. This can be built using a spare instrument sleeve available by quoting Part No. SUB26/SLE.

It is very important that power is turned on only after the controller has been inserted in the sleeve of the pre-wired circuit. Power should also be turned off before removing the controller from its sleeve.

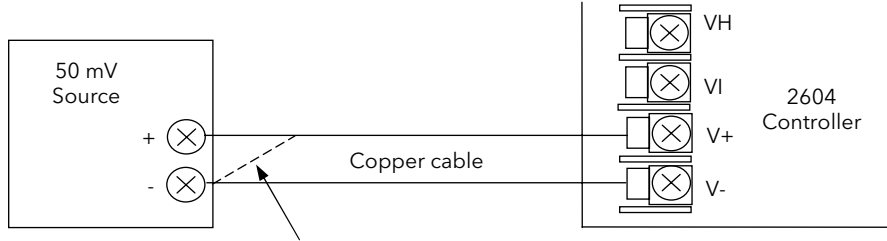
Allow at least 10 minutes for the controller to warm up after switch on.

Failure to observe these precautions will result in the controller not being calibrated to its full capability.

26.3 PV INPUT


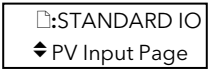



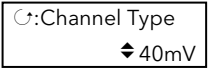



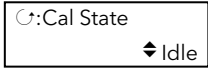
26.3.1 To Calibrate mV Range

Calibration of both 40 and 80 mV ranges for the PV Input is carried out using the same 50 milli-volt source. Pyrometer and mA calibration is included in this procedure. To calibrate thermocouples it is first necessary to calibrate the 40mV and 80mV ranges followed by CJC described in section 24.3.2.



For best results 0mV should be calibrated by disconnecting one of the copper wires from the mV source and short circuiting it to the other wire. This is particularly important to obtain best accuracy for RTD calibration


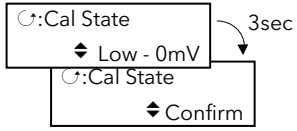


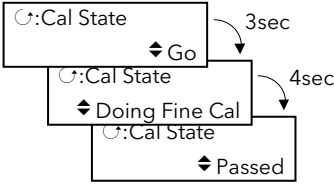

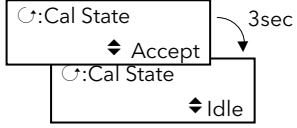

Figure 26-1: Connections for mV Range

Do This	This Is The Display You Should See	Additional Notes
1. From any display press  as many times as necessary until the 'STANDARD IO' page header is displayed.		To choose PV Input
2. Press  or  if necessary to select 'PV Input Page'		
15. Press  to show the first parameter in the page - in this example 'Channel Type'		Alternatively the 80mV range may be chosen
3. Press  or  to choose '40mV'		
4. Press  until the parameter 'Cal State' is displayed		

Do This	This Is The Display You Should See	Additional Notes
---------	------------------------------------	------------------



Calibrate at 0mV

5. Set the mV source to 0mV (or better by linking the two copper wires - Figure 24-1)



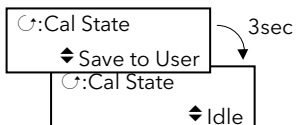

<p>6. Press  to choose 'Low - 0mV'</p>		<p>Calibration commences 3 seconds after (Go) is selected and 4 seconds later progresses to 'Passed'.</p> <p>If the message Failed appears this usually indicates that the input is not connected - press  to Abort</p> <p>Abort can be selected any point in this process.</p>
<p>7. Press  to confirm. The display will change to 'Go'</p>		
<p>8. Press  to choose 'Accept'</p>		<p>3 seconds after selecting 'Accept' the 0mV calibration becomes valid</p> <p>Alternatively press  to 'Abort'</p>

Calibrate at 50mV

9. Set the mV source to 50mV

<p>10. Press  to choose 'High - 50mV'</p>		
<p>11. Repeat steps 7 & 8</p>		

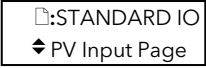



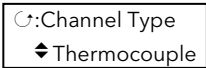



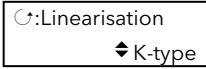





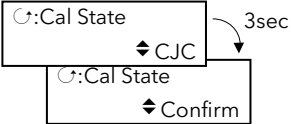
At this point the new calibration values are used by the controller. They will, however, be lost when the power to the controller is turned off. Complete the following step to store the values to the User Calibration area.

<p>12. Press  or  to choose 'Save to User'</p>		<p>3 seconds after selecting 'Save to User' the 0mV and 50 mV calibration values are stored and used by the controller.</p> <p>To return to factory calibration press  to 'Restore Factory', then choose 'Save to User'</p>
--	---	--

26.3.2 Thermocouple Calibration

Thermocouples are calibrated, firstly, by following the previous procedure for the 40mV and 80mV ranges, (both ranges should be calibrated to cover all types of thermocouple) then calibrating CJC.

This can be carried out using an external CJC reference source such as an ice bath or using a thermocouple mV source. Replace the copper cable shown in Figure 24-1 with the appropriate thermocouple compensating cable. Set the mV source to internal compensation for the thermocouple in use and set the output for 0mV. Then:-

Do This	This Is The Display You Should See	Additional Notes
1. Access the PV Input Page from STANDARD IO menu as described in the previous section		To choose PV Input
2. Press  to select ' Channel type ' 3. Press  or  to choose ' Thermocouple '		To configure the input for a thermocouple
4. Press  to select ' Linearisation ' 5. Press  or  to choose the linearisation curve for the thermocouple in use		To choose thermocouple linearisation curve Ensure that ' Rear Term Temp ' is set to ' Auto '. If not it will be necessary to accurately measure the temperature at the rear terminals and set this value accordingly
6. Press  until the parameter ' Cal State ' is displayed		
7. Press  or  to choose ' CJC ' Press  to 'Go'. 8. Then Accept and Save to User as described in Section 24.3.1. steps 8 and 12.		

26.3.3 Voltage Calibration

The procedure is identical to mV calibration with the exception that the low calibration point is 0V and the high point is 8V.

Note:- The voltage input terminals are VH and V- as detailed in the User Guide.

26.3.4 High Z Voltage Calibration

The procedure is identical to mV calibration with the exception that the low calibration point is 0V and the high point is 1V.

Note:- The voltage input terminals are VH and V- as detailed in the User Guide.

26.3.5 RTD Calibration

The two points at which RTD is calibrated are 150.00Ω and 400.00Ω.

Before starting RTD calibration:

- A decade box with total resistance lower than 1K must be connected in place of RTD as indicated on the connection diagram **before the instrument is powered up**. If at any instant the instrument was powered up without this connection then at least 1 hour must elapse from the time of restoring this connection before RTD calibration can take place.
- The instrument should be warmed up (powered up) for at least 10 minutes.

Before using or verifying RTD calibration:

- The above two points must be satisfied if the full accuracy is to be expected - see Note 2.
- The mV ranges must be calibrated - particularly the 0mV point. RTD calibration is incomplete without accurately calibrated mV ranges. Each instrument (or module) is calibrated to high standard in factory before shipment, therefore, the user does not need to perform mV calibration. If for any reasons this calibration was altered then 'Restore Factory' calibration and 'Save' facilities of mV ranges can be used. If on the other hand the RTD linearity is of a particular importance and the mV calibration was not checked/performed for several years than see Note 1.

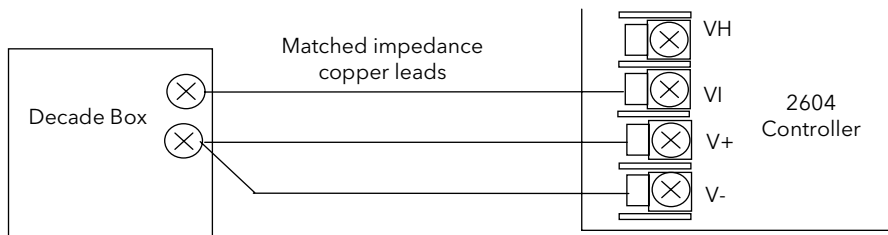


Figure 26-2: Connections for RTD

Note 1: - Proceed with mV calibration as described in section 24.3.1. making sure that 0mV is calibrated by short-circuiting the connecting copper wires and the same 50 mV source is used to calibrate high point on both 40 and 80 mV ranges. Also the calibration of both mV range should take place within short period of each other. As mV calibration requires disconnecting RTD or decade box it may be quicker to do RTD calibration first. However, do remember about 1-hour delay before being able to verify the calibration.

Note 2: - Typical extra errors to expect: ~0.5 °C within the first minute, ~0.2 °C within first 15 minutes, ~0.1 °C within first 1 hour.

Do This	This Is The Display You Should See	Additional Notes
1. For a controller calibrated for RTD type PT100, the views on the display should be as shown.		
2. Press until the parameter 'Cal State' is displayed		
3. Set the decade box for 150.00Ω	<p>Calibrate at 150 ohms.</p>	
4. Repeat procedure 24.3.1. steps 7 to 8	<p>Calibrate at 400 ohms.</p>	'Doing Fine Cal' for RTD takes about 30 seconds. This is about seven times longer than when calibrating mV
5. Set the decade box for 400.00Ω		
6. Repeat procedure 24.3.1. steps 11 to 12		

26.3.6 Analogue Input Calibration

Calibration of the Analogue input is carried out using an 8 volt ($\pm 2\text{mV}$) source. mA calibration is included in Volt calibration and assumes 100 Ω burden resistor across terminals BA & BB.

There are three conditions to be calibrated - **Offset**, **Common Mode Rejection** and **Gain**.

The use of a pre-wired jig is recommended assuming that all three conditions are to be calibrated. The connections for this are shown in Figure 24-3.

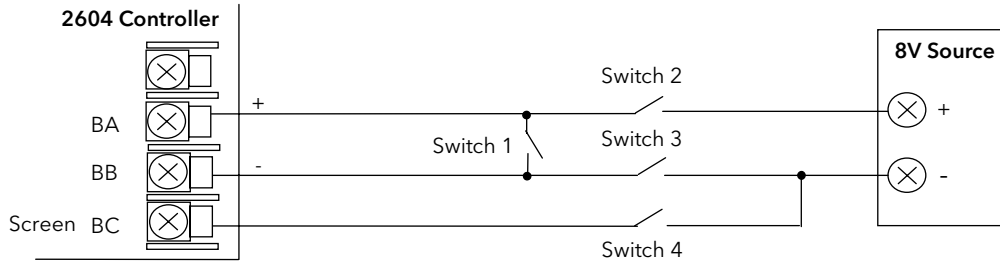


Figure 26-3: Analogue Input Calibration Connections

Do This	This Is The Display You Should See	Additional Notes
1. From any display press as many times as necessary until the 'STANDARD IO' page header is displayed.		
2. Press or if necessary to select 'An Input Page'		
3. Press to show the first parameter in the page - in this example 'Channel Type'		The Channel Type may be mA or Volts. The calibration procedure is the same.
4. Press or to choose 'mA' or 'Volts'		
5. Press until the parameter 'Cal State' is displayed		

To calibrate Offset

Connect + and - terminals together by closing switch 1. Open switches 2, 3 and 4 to allow the short circuited inputs to float.

6. Press or to choose 'Offset'		The procedure is now the same as paragraphs 7 to 12 for mV calibration.
----------------------------------	--	---

To calibrate Common Mode Rejection Ratio

Close switches 2 and 4, while switch 1 remains closed and switch 3 remains open, so that 8V is applied to both + and - input terminals with respect to the Screen terminal.






7. Press or to choose 'CMRR Enhance'		The procedure is now the same as paragraphs 7 to 12 for mV calibration.
--	--	---

To calibrate Gain

Open switches 1 and 4 and close switches 2 and 3 so that 8V is connected to both + and - input terminals while the screen is floating.

8. Press or to choose 'Gain'		The procedure is now the same as paragraphs 7 to 12 for mV calibration.
--------------------------------	--	---

26.3.7 To Restore Factory Calibration Values

Do This	This Is The Display You Should See	Additional Notes
1. Press  until the parameter ' Cal State ' is displayed		
2. Press  or  to choose ' Restore Factory '		The factory calibration values are restored for the input selected, i.e. if the Analogue Input is selected the PV Input and Module input values are not affected.

26.4 MODULE I/O

26.4.1 DC Output Module

The DC output module is calibrated in the factory at 10% and 90% of output level.

This is 1 and 9V for 0 to 10Vdc output and 2mA and 18mA for a 0 to 20mA output.

The factory calibration can be modified by the user by adjusting the 'Cal Trim' parameter, i.e. Actual Output = Factory Cal (Low & High) Value + User Cal (Low & High) Trim Value. The user trim value can be accepted and saved as for input calibration data.

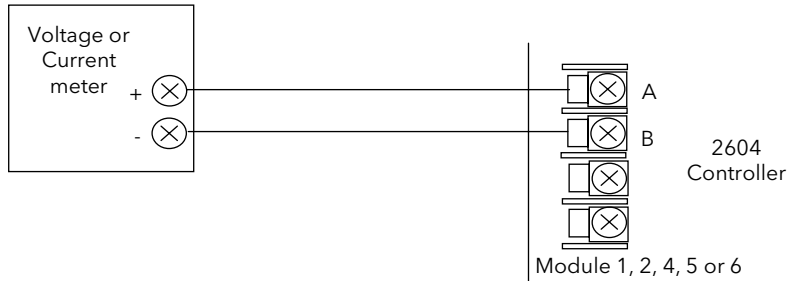



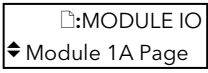



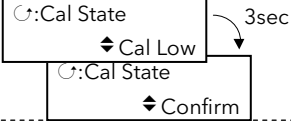

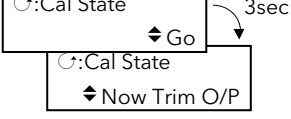

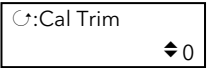




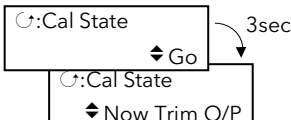


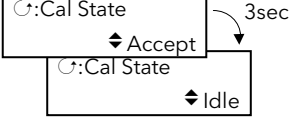

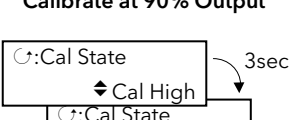




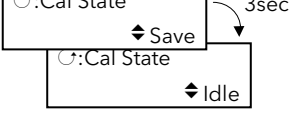

Figure 26-4: DC Module Connections Volts or Current Output

Do This	This Is The Display You Should See	Additional Notes
1. From any display press  as many times as necessary until the MODULE IO page header is displayed 2. Press  or  to choose the module in which the DC Output module is fitted		
3. Press  until the parameter 'Cal State' is displayed		Choices are: Idle Cal Low Cal High Restore Factory Save (only appears after cal procedure complete).

Do This	This Is The Display You Should See	Additional Notes
Calibrate at 10% Output		
4. Press  to choose 'Cal Low'	 <p>The diagram shows a menu box with 'Cal State' at the top, a cursor pointing to 'Cal Low', and a 'Confirm' option at the bottom. A 3-second timer is shown above the menu.</p>	<p>3 seconds after selecting 'Cal Low' the confirm message will appear.</p> <p>The other choice is 'Abort'</p>
5. Press  to choose 'Go'	 <p>The diagram shows a menu box with 'Cal State' at the top, a cursor pointing to 'Go', and a 'Now Trim O/P' option at the bottom. A 3-second timer is shown above the menu.</p>	
6. Press  to scroll to 'Cal Trim'	 <p>The diagram shows a menu box with 'Cal Trim' at the top and '0' at the bottom.</p>	<p>The adjustment is between -9999 and +9999. These numbers do not have units and are used for indication only.</p>
7. Press  or  to achieve the required output value read by the multimeter. 1.00 Vdc or 2.00mA		
8. Press and hold  while pressing  twice to return to 'Cal State'	 <p>The diagram shows a menu box with 'Cal State' at the top, a cursor pointing to 'Go', and a 'Now Trim O/P' option at the bottom. A 3-second timer is shown above the menu.</p>	<p>You can also scroll forward using the  button only. This, however, means that you will need to scroll through all parameters in the list.</p>
9. Press  to choose 'Accept'	 <p>The diagram shows a menu box with 'Cal State' at the top, a cursor pointing to 'Accept', and an 'Idle' option at the bottom. A 3-second timer is shown above the menu.</p>	<p>3 seconds later the calibration is accepted</p>
Calibrate at 90% Output		
10. Press  to choose 'Cal High'	 <p>The diagram shows a menu box with 'Cal State' at the top, a cursor pointing to 'Cal High', and a 'Confirm' option at the bottom. A 3-second timer is shown above the menu.</p>	

11. Repeat steps 6 to 10 to calibrate at 90% output. 9.00Vdc or 18mA

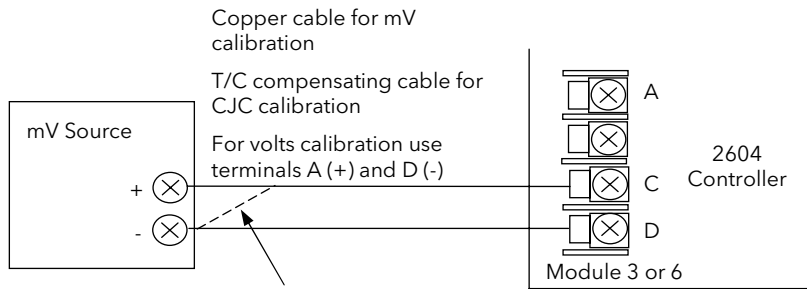
At this point the calibration values are used by the controller. They will, however, be lost when the power to the controller is turned off. From **Cal State/Idle**:

12. Press  or  to choose Save	 <p>The diagram shows a menu box with 'Cal State' at the top, a cursor pointing to 'Save', and an 'Idle' option at the bottom. A 3-second timer is shown above the menu.</p>	<p>The 10% and 90% calibration values are stored and used by the controller.</p> <p>To return to factory calibration press  to 'Restore Factory'. When 'Idle' appears choose 'Save'</p>
--	---	--

26.4.2 PV Input Module

PV Input modules can be fitted in positions 3 and 6. These modules can provide inputs for thermocouple, 3-wire RTD, mV, Volts or mA. The wiring connections for these inputs are shown below.

The calibration procedure is identical to that described in Section 24-3, but the **Cal State** parameter will be found under the page header **MODULE IO/Module 3 A Page** or **Module 6 A Page**.



For best results 0mV should be calibrated by disconnecting one of the copper wires from the mV source and short circuiting it to the other wire. This is particularly important to obtain best accuracy for RTD calibration

Figure 26-5: Volt, mV and Thermocouple Connections to Modules 3 & 6

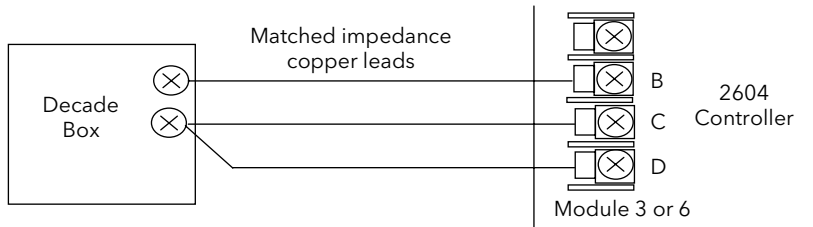


Figure 26-6: 3-Wire RTD Connections to Modules 3 & 6

26.4.3 Dual PV Input Module

The procedure is the same as the PV Input module above, but the parameter **'En Dual Mode'** in the Channel C parameter list must be set to **'No'**. **'Cal State'** is accessed from Channel A when enable dual mode is set to **'No'**.

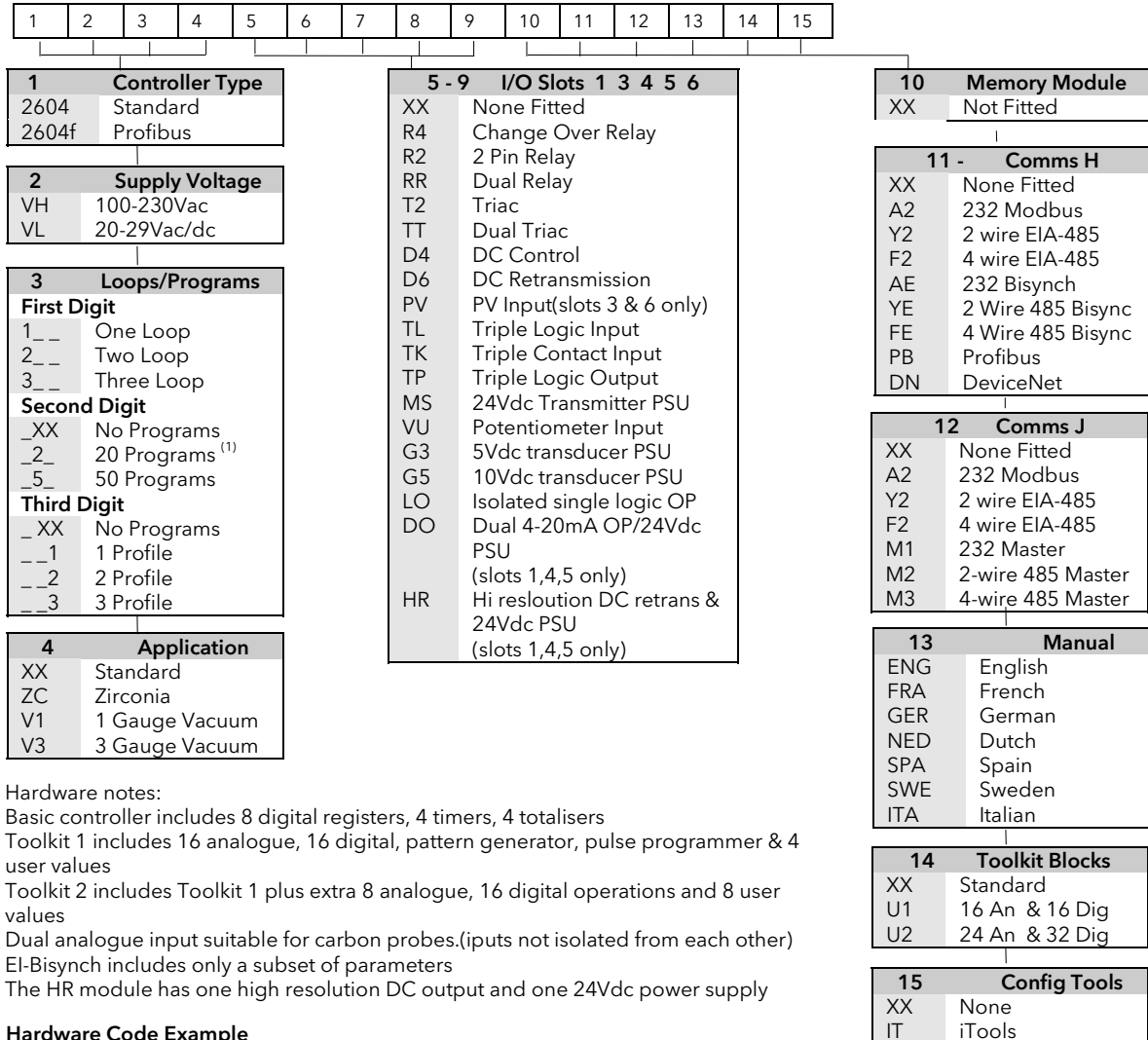
26.4.4 DC Input Module

The procedure is the same as the PV Input module above except that only a single mV range is available.

27.APPENDIX A ORDER CODE

27.1 HARDWARE CODE

The 2604 has a modular hardware construction, which accepts up to six plug-in modules and two comms modules. Eight digital IO and a relay form part of the fixed hardware build.



Hardware notes:

Basic controller includes 8 digital registers, 4 timers, 4 totalisers

Toolkit 1 includes 16 analogue, 16 digital, pattern generator, pulse programmer & 4 user values

Toolkit 2 includes Toolkit 1 plus extra 8 analogue, 16 digital operations and 8 user values

Dual analogue input suitable for carbon probes.(inputs not isolated from each other)

EI-Bisynch includes only a subset of parameters

The HR module has one high resolution DC output and one 24Vdc power supply

Hardware Code Example

2604/VH/323/XX/RR/PV/D4/TP/PV/XX/A2/XX/ENG/U1/IT

Three loop controller with capability to store 20 three profile programs. Supply voltage 85 - 264 Vac.

Modules: 2 x PV input, 1 x Dual relay, 1 x DC control, 1 x Triple logic output, EIA-232 Comms.

16 analogue and 32 digital operations and iTools supplied with controller.

27.2 CONFIGURATION CODING (OPTIONAL)

The controller supplied in accordance with the hardware code on the previous page requires to be configured. Configuration is carried out using iTools. Alternatively, for simple applications the controller may be supplied pre-configured using the following code:-

1	2	3	4	5	6	7	8	9	10	11	12
---	---	---	---	---	---	---	---	---	----	----	----

1 - 3 Loop function

First Digit

XXXX	None
S__	Standard PID
C__	Cascade
R__	Ratio
O__	Override ⁽⁷⁾

Other Digits

_PID	PID control
_ONF	On/Off control
_PIF	PID/OnOff control
_VP1	VP w/o feedback
_VP2	VP with feedback
_VP3	Dual VP w/o feedback
_VP4	Dual VP w/ithfeedback

7 Analogue Input

XXX	None
P2_	PV Loop 2
P3_	PV Loop 3
S1_	SP Loop 1
S2_	SP Loop 2
S3_	SP Loop 3
A1_	Aux PV Loop 1
A2_	Aux PV Loop 2
A3_	Aux PV Loop 3
L1_	Ratio lead PV Loop 1
L2_	Ratio lead PV Loop 2
L3_	Ratio lead PV Loop 3

Input range
Select third digit from table 1

8 - 12 Slot function

Loop number

XXX	Unconfigured
1__	Loop No 1
2__	Loop No 2
3__	Loop No 3

Single relay or triac

_HX	Heat
_CX	Cool

Dual relay or triac

_HC	PID Heat & Cool
_VH	VP Heat
_VC	VP Cool
_AA	FSH & FSH
_AB	FSH & FSL
_AC	DH & DL
_AD	FSH & DH
_AE	FSL & DL
_AF	FSH & FSL
_AG	FSH & DB
_AH	FSL & DB
_AJ	DB & DB
HHX	Heat O/P Ips 1 & 2
CCX	Cool O/P Ips 1 & 2
P12	Prog events 1 & 2
P34	Prog events 3 & 4
P56	Prog events 5 & 6
P78	Prog events 7 & 8

Triple logic output

_HX	Ch1 Heat
_CX	Ch1 Cool
_HC	Ch1 Heat, Ch2 Cool
HHX	Heat O/P Ips 1 & 2
HHH	Heat O/P Ips 1,2 & 3

Single DC outputs

H	PID Heat
C	PID Cool
T	PV Retransmission
S	SP Retransmission

For output range select third digit from table 1

Precision PV input

_PV	PV input Module
_PA	Aux PV Input ⁽⁸⁾
_PL	Ratio lead input

4 - 6 PV Inputs

X	None
J	J Thermocouple
K	K Thermocouple
T	T Thermocouple
L	L Thermocouple
N	N Thermocouple
R	R Thermocouple
S	S Thermocouple
B	B Thermocouple
P	P Thermocouple
C	C Thermocouple
Z	RTD/PT100
A	4-20mA linear
Y	0-20mA linear
V	0-10Vdc linear
W	0-5Vdc linear
G	1-5Vdc linear

Custom (Replace C)

Q	Custom curve
D	D Thermocouple
E	E Thermocouple
1	Ni/Ni18%Mo
2	Pt20%Rh/Pt40%Rh
3	W/W26%Re(Eng)
4	W/W26%Re(Hos)
5	W5%Re/W26%Re(Eng)
6	W5%Re/W26%Re(Hos)
7	Pt10%Rh/Pt40%Rh
8	Exergen K80 IR Pyro

Table 1

A	4-20mA linear
Y	0-20mA linear
V	0-10Vdc linear
W	0-5Vdc linear
G	1-5Vdc linear

Dual 4-20mA/24Vdc Tx OP

HHX	Heat OP Lps 1 & 2
_HC	Heat Cool
_HT	Ch 1 Heat, Ch 2 Tx
TTX	Both chs Txmtr

Changeover Relay

_HX	Heat
_CX	Cool

Potentiometer input

_VF	VP Heat Feedback
_VZ	VP Cool Feedback
_RS	Remote SP

Analogue Input *

R	Setpoint
-----	----------

Aux & lead PV inputs *

L	Ratio lead input
B	Aux PV input

* For input range select third digit from table 1

High Res DC Output

-TA	4-20mA PV retran
-TV	0-10V PV retran
-SA	4-20mA SP retran
-SV	0-10V SP retran

General Notes

1. Loop 1 PV defaults to main input on microboard. Loop 2 and 3 PV inputs must be fitted in I/O slots 3 or 6 or be assigned to the analogue input.
2. This alarm configuration refers to loop alarms only. One selection per loop is allowed. Additional alarms are available for the user to configure.
3. Thermocouple and RTD inputs assume sensor min and max values with no decimal point.
4. Linear inputs are ranged 0-100%, no decimal point.
5. Temperature inputs will be C unless ordered by USA where F will be supplied.
6. Remote setpoints assume loop min & max ranges.
7. VP1 or VP2 not available with override function.
8. For cascade and override inputs only.
9. HR module should be used in feedback mode.

27.3 QUICK START CODE EXAMPLE:

SVP1/SPID/SPID/K/Z/A/S1A/1VH/2PV/2HV/3HC/3PV

This code configures the hardware specified on page A2 to be:

Loop1: Valve position control, Type K input, Ch1 VP output in slot 1, 4-20mA remote setpoint input.

Loop 2: PID control, RTD input in slot 3, 0-10Vdc Ch1 output in slot 4.

Loop 3: PID control, 4-20mA input in slot 6, Logic Ch1/Ch2 output in slot 5.

28.APPENDIX B SAFETY AND EMC INFORMATION

This controller is manufactured in the UK by Eurotherm Controls Ltd.

Please read this section carefully before installing the controller

This controller is intended for industrial temperature and process control applications when it will meet the requirements of the European Directives on Safety and EMC. Use in other applications, or failure to observe the installation instructions of this handbook may impair the safety or EMC protection provided by the controller. It is the responsibility of the installer to ensure the safety and EMC of any particular installation.

28.1 SAFETY

This controller complies with the European Low Voltage Directive 2006/95/EC, amended by 93/68/EEC, by the application of the safety standard EN 61010.

28.1.1 Electromagnetic compatibility

This controller conforms with the essential protection requirements of the EMC Directive 2004/108/EC, amended by 93/68/EEC, by the application of a Technical Construction File.

This instrument satisfies the general requirements for heavy/light industrial and residential/commercial environments as described by EN 50081-1 and EN 50082-1. For more information on product compliance refer to the Technical Construction File.

28.2 SERVICE AND REPAIR

This controller has no user serviceable parts. Contact your supplier for repair.

Caution: Charged capacitors

Before removing an instrument from its sleeve, disconnect the supply and wait at least two minutes to allow capacitors to discharge. Failure to observe this precaution will expose capacitors that may be charged with hazardous voltages. In any case, avoid touching the exposed electronics of an instrument when withdrawing it from the sleeve.

28.2.1 Electrostatic discharge precautions

When the controller is removed from its sleeve, some of the exposed electronic components are vulnerable to damage by electrostatic discharge from someone handling the controller. To avoid this, before handling the unplugged controller discharge yourself to ground.

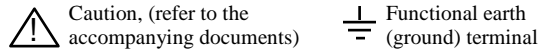
28.2.2 Cleaning

Do not use water or water based products to clean labels or they will become illegible. Isopropyl alcohol may be used to clean labels. A mild soap solution may be used to clean other exterior surfaces of the product.

28.3 INSTALLATION SAFETY REQUIREMENTS

28.3.1 Safety Symbols

Various symbols are used on the instrument, they have the following meaning:



The functional earth connection is not required for safety purposes but to ground RFI filters.

28.3.2 Personnel

Installation must only be carried out by qualified personnel.

28.3.3 Enclosure of live parts

To prevent hands or metal tools touching parts that may be electrically live, the controller must be installed in an enclosure.

28.3.4 Isolation

The fixed digital I/O and analogue input are not isolated. The PV Input and all plug in modules are fully isolated. This is shown in Figure B-1.

The Analogue Input is a self biased differential input suitable for either grounded or floating transducers of low output impedance generating signal in the range of +/-10V or +/-20mA (with a burden resistor of 100 Ohms across + and - terminals).

This input is neither isolated from the instrument ground (which can be earthed via fixed I/O ports) nor isolated from the instrument earth terminal, therefore, under no circumstances should mains potentials be applied to any of its inputs.

In order for the Input to operate safely the common voltage at the inputs measured with respect to instrument ground should not exceed +/-120Vdc or $a_{c,rms}$. For actively enhanced common mode rejection (i.e. operation within the spec.) this voltage should be limited to +/- 40Vdc.

Floating transducers will automatically be biased to +2.5V with respect to instrument ground upon connection.

Note: All the other I/Os are fully isolated from the instrument ground and each other.

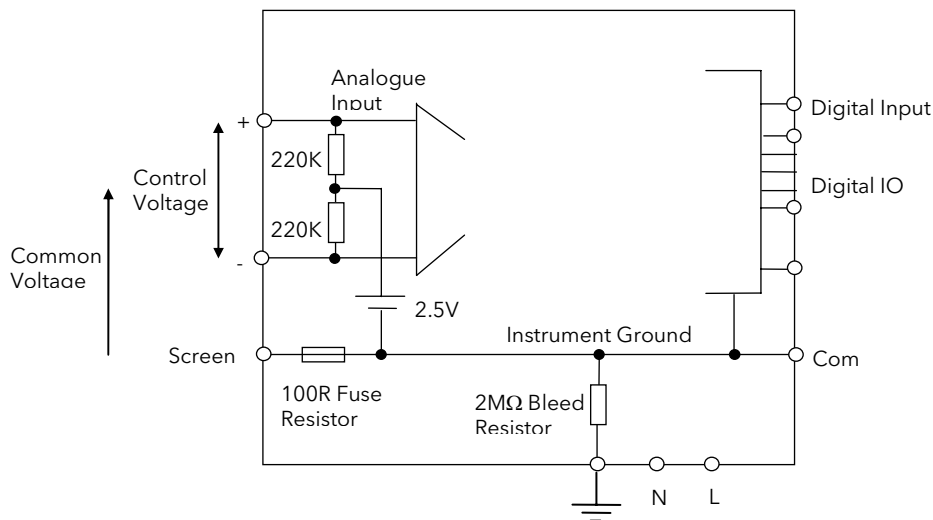


Figure 28-1: Analogue Input and Fixed Digital I/O Equivalent Circuit

28.3.5 Wiring

It is important to connect the controller in accordance with the wiring data given in this handbook. Take particular care not to connect AC supplies to the low voltage sensor input or other low level inputs and outputs. Only use copper conductors for connections (except thermocouple inputs) and ensure that the wiring of installations comply with all local wiring regulations. For example in the UK use the latest version of the IEE wiring regulations, (BS7671). In the USA use NEC Class 1 wiring methods.

28.3.6 Power Isolation

The installation must include a power isolating switch or circuit breaker. This device should be in close proximity to the controller, within easy reach of the operator and marked as the disconnecting device for the instrument.

28.3.7 Earth leakage current

Due to RFI Filtering there is an earth leakage current of less than 0.5mA. This may affect the design of an installation of multiple controllers protected by Residual Current Device, (RCD) or Ground Fault Detector, (GFD) type circuit breakers.

28.3.8 Overcurrent protection

To protect the internal PCB tracking within the controller against excess currents, the AC power supply to the controller and power outputs must be wired through the fuse or circuit breaker specified in the technical specification.

28.3.9 Voltage rating

The maximum continuous voltage applied between any of the following terminals must not exceed 264Vac:

- line or neutral to any other connection;
- relay or triac output to logic, dc or sensor connections;
- any connection to ground.

The controller should not be wired to a three phase supply with an unearthed star connection. Under fault conditions such a supply could rise above 264Vac with respect to ground and the product would not be safe.

Voltage transients across the power supply connections, and between the power supply and ground, must not exceed 2.5kV. Where occasional voltage transients over 2.5kV are expected or measured, the power installation to both the instrument supply and load circuits should include a transient limiting device.

These units will typically include gas discharge tubes and metal oxide varistors that limit and control voltage transients on the supply line due to lightning strikes or inductive load switching. Devices are available in a range of energy ratings and should be selected to suit conditions at the installation.

28.3.10 Conductive pollution

Electrically conductive pollution must be excluded from the cabinet in which the controller is mounted. For example, carbon dust is a form of electrically conductive pollution. To secure a suitable atmosphere in conditions of conductive pollution, fit an air filter to the air intake of the cabinet. Where condensation is likely, for example at low temperatures, include a thermostatically controlled heater in the cabinet.

28.3.11 Over-temperature protection

When designing any control system it is essential to consider what will happen if any part of the system should fail. In temperature control applications the primary danger is that the heating will remain constantly on. Apart from spoiling the product, this could damage any process machinery being controlled, or even cause a fire.

Reasons why the heating might remain constantly on include:

- the temperature sensor becoming detached from the process;
- thermocouple wiring becoming short circuit;
- the controller failing with its heating output constantly on;
- an external valve or contactor sticking in the heating condition;
- the controller setpoint set too high.

Where damage or injury is possible, we recommend fitting a separate over-temperature protection unit, with an independent temperature sensor, which will isolate the heating circuit.

Please note that the alarm relays within the controller will not give protection under all failure conditions.

28.3.12 Grounding of the temperature sensor shield

In some installations it is common practice to replace the temperature sensor while the controller is still powered up. Under these conditions, as additional protection against electric shock, we recommend that the shield of the temperature sensor is grounded. Do not rely on grounding through the framework of the machine.

28.4 INSTALLATION REQUIREMENTS FOR EMC

To ensure compliance with the European EMC directive certain installation precautions are necessary as follows:

- For general guidance refer to EMC Installation Guide, HA025464.
- When using relay or triac outputs it may be necessary to fit a filter suitable for suppressing the emissions. The filter requirements will depend on the type of load.
- If the unit is used in a portable enclosure which is plugged into a standard power socket, then it is likely that compliance to the commercial and light industrial emissions standard is required. In this case to meet the conducted emissions requirement, a suitable mains filter should be installed.

28.4.1 Routing of wires

To minimise the pick-up of electrical noise, the wiring for low voltage dc and particularly the sensor input should be routed away from high-current power cables. Where it is impractical to do this, use shielded cables with the shield grounded at both ends.

29.APPENDIX C TECHNICAL SPECIFICATION

All figures quoted at 0 to 50°C unless otherwise stated.

29.1 ALL ANALOGUE, DUAL AND PV INPUTS

Sample rate	9Hz (110msec.)
Input filtering	OFF to 999.9 seconds of filter time constant (f.t.c.). Default setting is 0.4 seconds unless stated otherwise
User calibration	Both the user calibration and a transducer scaling can be applied.
Sensor break	a.c. sensor break on each input (i.e. fast responding and no dc errors with high impedance sources).
Thermocouple types	Most linearisations including K,J,T,R,B,S,N,L,PlI,C,D,E with linearisation error < $\pm 0.2^{\circ}\text{C}$
General	Resolution (noise free) is quoted as a typical figure with f.t.c. set to the default value = 0.4 second. Resolution generally improves by a factor of two with every quadrupling of f.t.c. Calibration is quoted as offset error + percentage error of absolute reading at ambient temperature of 25°C Drift is quoted as extra offset and absolute reading errors per degree of ambient change from 25°C.

29.2 PRECISION PV INPUT / MODULE

Allocation (isolated)	One standard and up to two additional PV input modules can be fitted in I/O slots 3 and 6
mV input	Two ranges: $\pm 40\text{mV}$ & $\pm 80\text{mV}$, used for thermocouple, linear mV source or 0 - 20mA with 2.49 Ω Calibration: $\pm(1.5\mu\text{V} + 0.05\%$ of reading), Resolution: 0.5 μV for 40mV range & 1 μV for 80mV range Drift: $<\pm(0.05\mu\text{V} + 0.003\%$ of absolute reading) per °C Input impedance: >100M Ω , Leakage: < 1nA
0 - 2V input	-1.4V to +2V, used for zirconia Calibration: $\pm(0.5\text{mV} + 0.05\%$ of reading) Resolution: 60 μV Drift: $<\pm(0.05\text{mV} + 0.003\%$ of reading) per °C Input impedance: >100M Ω , Leakage: < 1nA
0 - 10V input	-3V to +10V, used for voltage input Calibration: $\pm(0.5\text{mV} + 0.1\%$ of reading) Resolution: 180 μV Drift: $<\pm(0.1\text{mV} + 0.01\%$ of reading) per °C Input impedance: 0.66M Ω
Pt100 input	0 to 400ohms (-200°C to +850°C), 3 matched wires - up to 22 Ω in each lead without errors. Calibration: $\pm(0.1^{\circ}\text{C} + 0.04\%$ of reading in °C) Resolution: 0.02°C Drift: $<\pm(0.006^{\circ}\text{C} + 0.002\%$ of absolute reading in °C) per °C Bulb current: 0.2mA.
Thermocouple	Internal compensation: CJC rejection ratio >40:1 typical. CJ Temperature calibration error at 25°C: $<\pm 0.5^{\circ}\text{C}$ 0°C, 45°C and 50°C external compensation available.
Zirconia probes	Most probes supported. Continuous monitoring of probe impedance (100 Ω to 100K Ω)

29.3 DUAL (PROBE) INPUT MODULE

General	The same specification as for the Precision PV Input module applies with the exception of the following: Module offers two sensor/transmitter inputs, which share the same negative input terminal. One low level (mV, 0-20mA, thermocouple, Pt100) and one high level (0-2Vdc, 0-10Vdc) can be connected
Isolation	The two inputs are isolated from the rest of the instrument but not from each other
Sample rate (each input)	4.5Hz (220msec)
Input filtering	Default setting is 0.8 seconds

29.4 ANALOGUE INPUT

No of inputs	One fixed (Not isolated) Can be used with either floating or ground referenced transducers of low impedance.
Input range	-10V to +10V linear or 0 -20 mA with burden resistor of 100 Ω . Calibration: $\pm(1.5\text{mV} + 0.1\%$ of reading) Resolution: 0.9mV Drift: $< \pm(0.1\text{mV} + 0.006\%$ of reading) per $^{\circ}\text{C}$ Input Impedance: 0.46M Ω (floating input), 0.23M Ω (ground referenced input)
Isolation	Not isolated from standard digital I/O . Differential type input with common mode range of $\pm 42\text{Vdc}$ (the average voltage of the two inputs with respect to 'Screen' or 'Common' terminals should be within $\pm 42\text{Vdc}$. CMRR : $>110\text{dB}$ at 50/60Hz, $>80\text{dB}$ at DC
Functions	Process variable, remote setpoint, power limit, feedforward, etc.

29.5 ANALOGUE INPUT MODULE

Allocation	Up to 4 analogue input modules can be fitted in I/O slots 1,3,4 & 6
mV input	100mV range - used for thermocouple, linear mV source, or 0-20mA with 2.49 Ω external burden resistor. Calibration: $\pm 10\mu\text{V} + 0.2\%$ of reading Resolution: 6 μV Drift: $< \pm 0.2\mu\text{V} + 0.004\%$ of reading per $^{\circ}\text{C}$ Input impedance: $>10\text{M}\Omega$, Leakage: $<10\text{nA}$
0 - 2Vdc input	-0.2V to +2.0V range - used for zirconia. Calibration: $\pm 2\text{mV} + 0.2\%$ of reading Resolution: 30 μV Drift: $< \pm 0.1\text{mV} + 0.004\%$ of reading per $^{\circ}\text{C}$ Input impedance: $>10\text{M}\Omega$, Leakage: $<20\text{nA}$
0 - 10Vdc input	-3V to +10.0V range - used for voltage input. Calibration: $\pm 2\text{mV} + 0.2\%$ of reading Resolution: 200 μV Drift: $< \pm 0.1\text{mV} + 0.02\%$ of reading per $^{\circ}\text{C}$ Input impedance: $>69\text{K}\Omega$
Pt100 input	0 to 400ohms (-200 $^{\circ}\text{C}$ to +850 $^{\circ}\text{C}$), 3 matched wires - up to 22 Ω in each lead without errors. Calibration: $\pm(0.4^{\circ}\text{C} + 0.15\%$ of reading in $^{\circ}\text{C}$) Resolution: 0.08 $^{\circ}\text{C}$ Drift: $< \pm(0.015^{\circ}\text{C} + 0.005\%$ of reading in $^{\circ}\text{C}$) per $^{\circ}\text{C}$ Bulb current: 0.3mA.
Thermocouple	Internal compensation: CJC rejection ratio $>25:1$ typical. CJ Temperature calibration error at 25 $^{\circ}\text{C}$: $< \pm 2^{\circ}\text{C}$ 0 $^{\circ}\text{C}$, 45 $^{\circ}\text{C}$ and 50 $^{\circ}\text{C}$ external compensation available.

29.6 STANDARD DIGITAL I/O

Allocation not isolated	1 digital input standard and 7 I/O which can be configured as inputs or outputs plus 1 changeover relay
Digital inputs	Voltage level : input active < 2Vdc, inactive >4Vdc Contact closure : input active <100ohms, inactive >28kohms
Digital outputs	Open collector, 24Vdc at 40mA drive capability, requires external supply
Changeover relay	Contact rating 2A at 264Vac resistive
Functions	Refer to Chapter 17
Operations	1,000,000 operations with addition of external snubber

29.7 DIGITAL INPUT MODULES

Module type	Triple contact input, Triple logic input
Allocation	Can be fitted into slots 1, 3, 4, 5 or 6
Contact closure	Active <100ohms, inactive >28kohms
Logic inputs	Current sinking : active 10.8Vdc to 30Vdc at 2.5mA inactive -3 to 5Vdc at <-0.4mA
Functions	Refer to Chapter 18

29.8 DIGITAL OUTPUT MODULES

Module types	Single relay, dual relay, single triac, dual triac, triple logic module (isolated)
Allocation	Can be fitted into slot 1, 3, 4, 5 or 6 (max. 3 triac modules per instrument)
Relay rating	2A, 264Vac resistive
Logic drive	12Vdc at 9mA
Triac rating	0.75A, 264Vac resistive
Functions	Refer to Chapter 18

29.9 ANALOGUE OUTPUT MODULES

Module types	1 channel DC control, 1 channel DC retransmission (5 max.)
Allocation (isolated)	Can be fitted into slot 1, 3, 4, 5 or 6
Range	0-20mA, 0-10Vdc
Resolution	1 part in 10,000 (2,000-noise free) 0.5% accurate for retransmission 1 part in 10,000 2.5% accurate for control
Functions	Refer to Chapter 18

29.10 TRANSMITTER PSU

Allocation	Can be fitted into slots 1, 3, 4, 5 or 6 (isolated)
Transmitter	24Vdc at 20mA

29.11 TRANSDUCER PSU

Bridge voltage	Software selectable 5 or 10Vdc
Bridge resistance	300Ω to 15KΩ
Internal shunt resistor	30.1KΩ at 0.25%, used for calibration of 350Ω bridge

29.12 DUAL DC OUTPUT

Current Output	4-20mA, 20V output span
Accuracy	1%, 11 bit noise free resolution
Speed	50ms response
Transmitter/logic PSU	20V min at full 22mA current load. 30V max at open circuit short circuit protected at 22-24mA

29.13 HIGH RESOLUTION DC OUTPUT

Current Output	4-20mA, 20V output span
Accuracy	1%, 15 bit noise free resolution
Speed	40ms response
Transmitter/logic PSU	20V min at full 22mA current load. 30V max at open circuit short circuit protected at 21-28mA

29.14 POTENTIOMETER INPUT

Potentiometer resistance	100 Ω to 15K Ω , excitation of 0.5 volts
--------------------------	--

29.15 DIGITAL COMMUNICATIONS

Allocation	2 modules fitted in slots H & J (isolated)
Modbus	RS232, 2 wire or 4 wire RS485, max baud 19.2KB in H module & 9.6KB in J module
Profibus-DP	High speed, RS485, 1.5Mbaud

29.16 ALARMS

No of Alarms	Input alarms (2), loop alarms (2) User alarms (8)
Alarm types	Full scale, deviation, rate of change, sensor break plus application specific
Modes	Latching or non-latching, blocking, time delay
Parameters	Refer to Chapter 8

29.17 USER MESSAGES

No of messages	Maximum 50, triggered by operator or alarm or used for custom parameter names
Format	Up to 16 characters

29.18 CONTROL FUNCTIONS

No of loops	One, two or three
Modes	On/off, PID, motorised valve with or without feedback
Options	Cascade, ratio, override or feed forward
Cooling algorithms	Linear, water, oil or fan
PID sets	3 per loop (Cascade loop includes master and slave parameters)
Manual mode	Bumpless transfer or forced manual output, manual tracking available
Setpoint rate limit	Display units per second, minute or hour

29.19 SETPOINT PROGRAMMER

No of programs	A maximum of 50 programs assignable over 500 segments for a time to target programmer and 400 segments for a ramp rate programmer. A program can consist of up to 3 variables. Programs can be given user defined 16 character names
Event outputs	Up to 16, can be assigned individually to segments or called as part of an event group

29.20 ADVANCED FUNCTIONS

Application blocks	32 digital operations 24 Analogue calculations
Timers	4, On Pulse, Off delay, one shot and min-On
Totalisers	4, trigger level & reset input
Real time clock	Day of week and time
Pattern generators	16 x 16, 2 off

29.21 GENERAL SPECIFICATION

Display range	5 digits including up to 3 decimal places
Power Supply	High Voltage; 100-230Vac, 20 Watts (max) Low Voltage; 24Vac -15/+10%, 48-62Hz. 24Vdc -15/+20% 20 Watts (max)
Operating ambient	0 - 50°C and 5 to 95% RH non condensing
Storage temp	-10 to +70°C
Panel sealing	IP65
Dimensions	96H x 96W x 150D (mm)
EMC standards	EN50081-1 & EN50082-2 generic standards - suitable for domestic, commercial and light industrial as well as heavy industrial environments
Safety standards	Meets EN61010 installation category II, pollution degree 2
Atmospheres	Not suitable for use above 2000m or in explosive or corrosive atmospheres
Inrush Current	High Voltage controller - 30A duration 100µs Low Voltage controller - 15A duration 100µs

29.22 GRAPHICAL REPRESENTATION OF ERRORS

This section shows graphically the effects of adding all contributions of different errors for each input type and range. The errors are a combination of:

Calibration accuracy, Drift with ambient temperature, Linearity error, Leakage

29.22.1 mV Input

Two ranges:

working range	$\pm 40\text{mV}$		
full linear range	$\pm 60\text{mV}$		
noise (resolution)	1 μV - OFF,	0.5 μV - 0.4sec,	0.25 μV - 1.6sec
working range	$\pm 80\text{mV}$		
full linear range	$\pm 105\text{mV}$		
noise (resolution)	2 μV - OFF,	1 μV - 0.4sec,	0.5 μV - 1.6sec

Calibration accuracy @ 25°C

$$< \pm (1.5\mu\text{V} + 0.05\% \text{ of } |\text{reading}|)$$

Drift with ambient temperature

$$< \pm (0.05\mu\text{V} + 0.003\% \text{ of } |\text{reading}|) \text{ per } ^\circ\text{C}$$

Linearity error

$$< \pm 0.002\% \text{ of span (i.e. } < 1\mu\text{V, } < 2\mu\text{V)}$$

Leakage

$$< \pm 1\text{nA (typically } \pm 200\text{pA)}$$

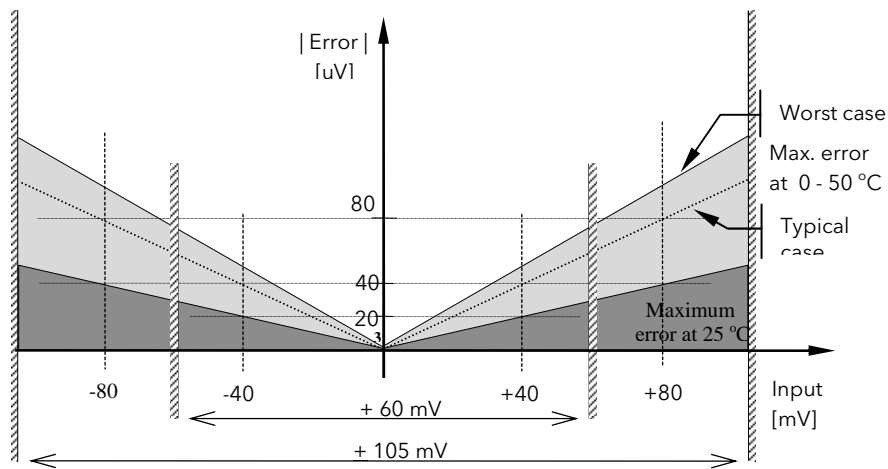


Figure 29-1: Error Graph - mV Input

29.22.2 Mid range high impedance Input

0 - 2V Input type

Range:

working range -1.4V to +2V

full linear range -1.8V to +2.4V

noise (resolution) 100uV - OFF, 50uV - 0.4sec, 35uV - 1.6sec

Calibration accuracy @ 25°C

$< \pm(0.5\text{mV} + 0.05\% \text{ of } |\text{reading}|)$

Drift with ambient temperature

$< \pm(0.05\text{mV} + 0.003\% \text{ of } |\text{reading}|) \text{ per } ^\circ\text{C}$

Linearity error

$< \pm 0.01\% \text{ of span}$ (i.e. $\pm 200\text{uV}$)

Input Impedance & Leakage

$> 100\text{M}\Omega$ $< 1\text{nA}$

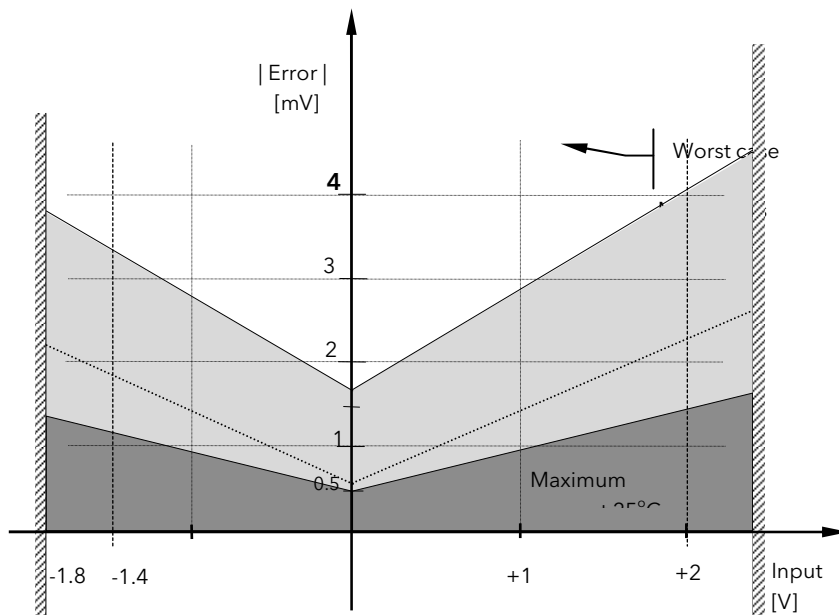


Figure 29-2: Error Graph - 0 - 2V Input

29.22.3 High Level Input

0 - 10V Input type

Range:

working range	-3V to +10V
full linear range	- 5V to +14V
noise (resolution)	300uV - OFF, 150uV - 0.4sec, 100uV - 1.6sec

Calibration accuracy @ 25°C

$$< \pm(0.5\text{mV} + 0.1\% \text{ of } |\text{reading}|)$$

Drift with ambient temperature

$$< \pm(0.01\text{mV} + 0.006\% \text{ of } |\text{reading}|) \text{ per } ^\circ\text{C}$$

Linearity error

$$< \pm 0.02\% \text{ of span (i.e. } \pm 2\text{mV)}$$

Input Impedance

0.66 MΩ

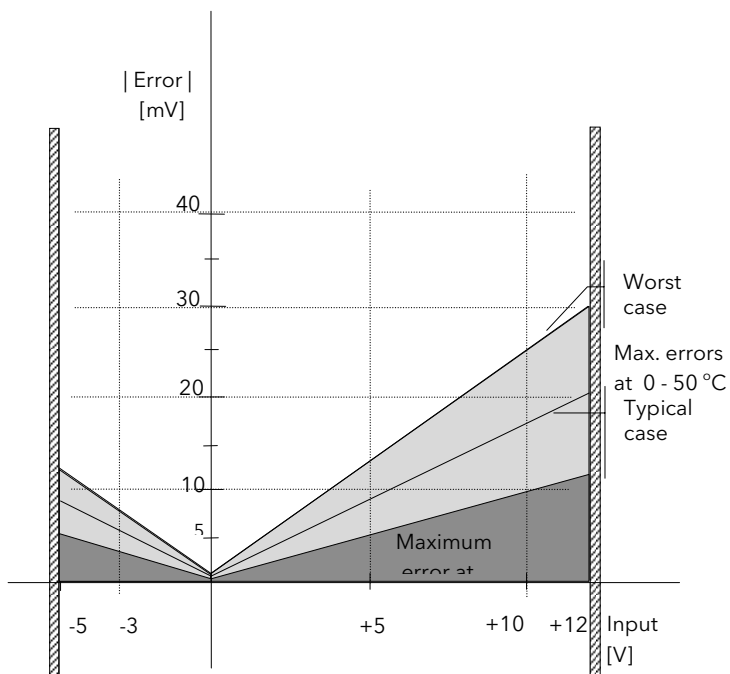


Figure 29-3: Error Graph - 0 - 10V Input

29.22.4 RTD (Pt-100) Input type

Resistance measurement specification in Ohms:

Range

0 to 400 Ω with up to 22 Ω in each connecting lead

Noise (resolution)

8m Ω - 0.4sec, 4m Ω - 1.6sec

Calibration accuracy limits @ 25 $^{\circ}$ C

$< \pm (35\text{m}\Omega @ 110\Omega + 0.03\% \text{ of } |\text{reading} - 110\Omega|)$

Drift with ambient temperature

$\pm (0.002\% \text{ of } |\text{reading}|) \text{ per } ^{\circ}\text{C}$

Linearity error

$< \pm 15 \text{ m}\Omega$

Pt-100 measurement specification in $^{\circ}$ C:

Range

-200 $^{\circ}$ C to +850 $^{\circ}$ C

Noise (resolution)

0.02 $^{\circ}$ C - 0.4sec, 0.01 $^{\circ}$ C - 1.6sec

Calibration accuracy limit @ 25 $^{\circ}$ C

$< \pm (0.1 \text{ } ^{\circ}\text{C} + 0.03\% \text{ of } |\text{reading in } ^{\circ}\text{C}|)$

Drift with ambient temperature

$< \pm (0.0055 \text{ } ^{\circ}\text{C} + 0.002\% \text{ of } |\text{reading in } ^{\circ}\text{C}|) \text{ per } ^{\circ}\text{C} \text{ of ambient change}$

Linearity + Linearisation error

$< \pm 55 \text{ } ^{\circ}\text{mC}$ (i.e. 50 $^{\circ}\text{mC} + 5 \text{ } ^{\circ}\text{mC}$)

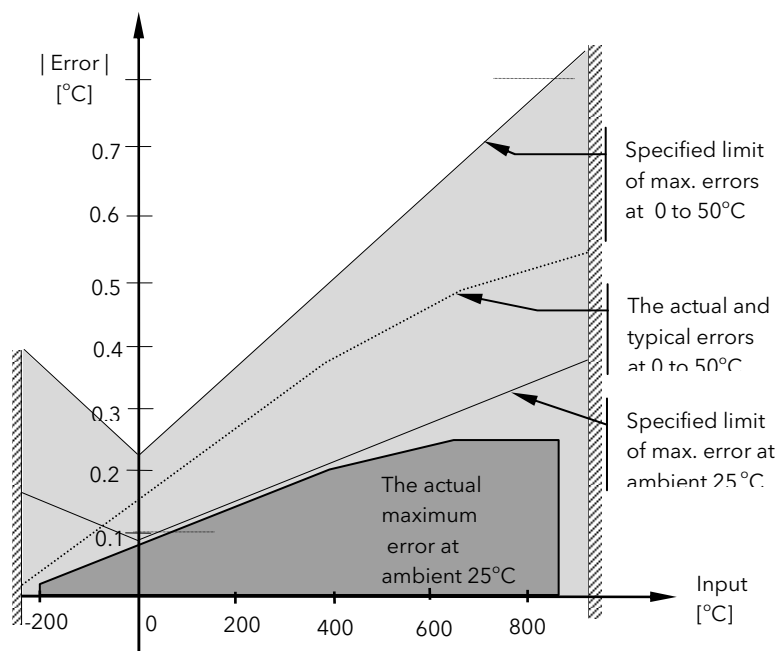


Figure 29-4: Error Graph - RTD Input

29.22.5 Thermocouple Input type

Internal CJT sensing spec

Calibration error @ 25 °C (including temp. difference between top and bottom screws)

$< \pm 0.5^\circ\text{C}$

Total CJT error

$< \pm (0.5^\circ\text{C} + 0.012^\circ\text{C per } 1^\circ\text{C of ambient change})$

(i.e. CJC Rejection for measured temperatures above 0 °C is $> 80 : 1$)

Noise (resolution)

0.01 °C

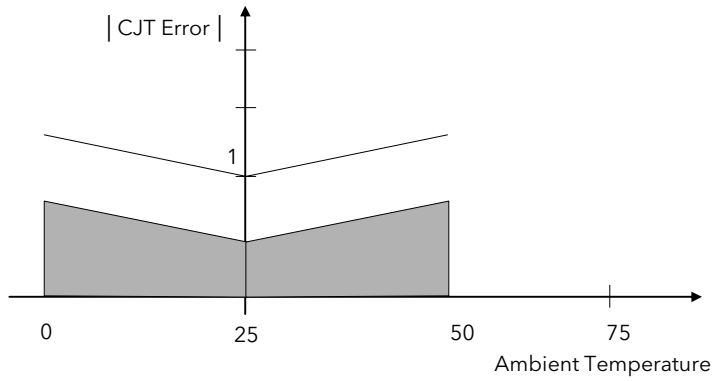


Figure 29-5: Overall CJT Error at Different Ambient Temperatures

30.APPENDIX D PARAMETER UNITS AND ADDRESSES

30.1 COMMONLY USED PARAMETERS

Any parameter can be chosen for Soft Wiring, Parameter Promotion or Customised Display purposes by using its Modbus address. The address of any parameter can be found by using iTools. However, the controller contains a list a commonly used parameters showing both their Modbus addresses and the mnemonic of the the parameter. These parameters are shown in the following table:

Parameter Name	Parameter Description	Refer To Section:-	Modbus Address
None	None		00000
L1.PV	Loop1 PV	Chapter 9	00001
L1.Wkg OP	Loop1 working output	LP1 SETUP	00004
L1.Wkg SP	Loop1 working setpoint	Diagnostic Page	00005
L1.Ch1 OP	Loop1 channel 1 output	Output Page	00013
L1.Ch2 OP	Loop1 channel 2 output	Output Page	00014
L2.PV	Loop2 PV	Chapter 9	01025
L2.Wkg OP	Loop2 working output	LP2 SETUP	01028
L2.Wkg SP	Loop2 working setpoint	Diagnostic Page	01029
L2.Ch1 OP	Loop2 channel 1 output	Output Page	01037
L2.Ch2 OP	Loop2 channel 2 output	Output Page	01038
L3.PV	Loop3 PV	Chapter 9	02049
L3Wkg OP	Loop3 working output	LP3 SETUP	02052
L3Wkg SP	Loop3 working setpoint	Diagnostic Page	02053
L3Ch1 OP	Loop3 channel 1 output	Output Page	02061
L3Ch2 OP	Loop3 channel 2 output	Output Page	02062
CLin1.OP	Custom linearisation 1	Chapter 11 INPUT OPERS Cust Lin 1	03365
CLin2.OP	Custom linearisation 2	Cust Lin 2	03413
CLin3.OP	Custom linearisation 3	Cust Lin 3	03461
SwOv1.OP	Switchover output value	Switch 1 Page	03477
Mod1A.Val	Module 1A output value	Chapter 18 MODULE IO Module 1A page	04148
Mod1B.Val	Module 1B output value	Module 1B page	04196
Mod1C.Val	Module 1C output value	Module 1C page	04244
Mod3A.Val	Module 3A output value	Module 3A page	04468
Mod3B.Val	Module 3B output value	Module 3B page	04516
Mod3C.Val	Module 3C output value	Module 3C page	04564
Mod4A.Val	Module 4A output value	Module 4A page	04628
Mod4B.Val	Module 4B output value	Module 4B page	04676
Mod4C.Val	Module 4C output value	Module 4C page	04724
Mod5A.Val	Module 5A output value	Module 5A page	04788
Mod5B.Val	Module 5B output value	Module 5B page	04836
Mod5C.Val	Module 5C output value	Module 5C page	04884
Mod6A.Val	Module 6A output value	Module 6A page	04948
Mod6B.Val	Module 6B output value	Module 6B page	04996
Mod6C.Val	Module 6C output value	Module 6C page	05044
PVIn.Val	PV input value	Chapter 17 STANDARD IO PV Input page	05108
AnIn.Val	Analogue input value	An Input Page	05268
DIO1.Val	Digital input/output value 1	Dig IO1 Page	05402
DIO2.Val	Digital input/output value 2	Dig IO2 Page	05450
DIO3.Val	Digital input/output value 3	Dig IO3 Page	05498
DIO4.Val	Digital input/output value 4	Dig IO4 Page	05546
DIO5.Val	Digital input/output value 5	Dig IO5 Page	05594
DIO6.Val	Digital input/output value 6	Dig IO6 Page	05642
DIO7.Val	Digital input/output value 7	Dig IO7 Page	05690
Prg.PSP1	Programmer working SP1	Chapter 6 RUN PSP1 Page	05800
Prg.PSP2	Programmer working SP2	PSP2 Page	05801
Prg.PSP3	Programmer working SP3	PSP3 Page	05802

Prg.Uval1	Programmer user value 1	PROGRAM EDIT Segment Page	05808
Prg.Uval2	Programmer user value 2	PROGRAM EDIT Segment Page	05809
Prg.DO1	Programmer digital OP1	Chapter 6 RUN General Page	05869
Prg.DO2	Programmer digital OP2		05870
Prg.DO3	Programmer digital OP3		05871
Prg.DO4	Programmer digital OP4		05872
Prg.DO5	Programmer digital OP5		05873
Prg.DO6	Programmer digital OP6		05874
Prg.DO7	Programmer digital OP7		05875
Prg.DO8	Programmer digital OP8		05876
ProgEnd	End of Program		05892
ProgRun	Program run	05893	
ProgHold	Program hold	05894	
ProgNewSe	Program new segment	05895	
ProgReset	Program reset	05906	

AnOp1.OP	Analogue operator OP1	Chapter 14 ANALOGUE OPERS Analogue 1 Page	06158
AnOp2.OP	Analogue operator OP2	Analogue 2 Page	06178
AnOp3.OP	Analogue operator OP3	Analogue 3 Page	06198
AnOp4.OP	Analogue operator OP4	Analogue 4 Page	06218
AnOp5.OP	Analogue operator OP5	Analogue 5 Page	06238
AnOp6.OP	Analogue operator OP6	Analogue 6 Page	06258
AnOp7.OP	Analogue operator OP7	Analogue 7 Page	06278
AnOp8.OP	Analogue operator OP8	Analogue 8 Page	06298
AnOp9.OP	Analogue operator OP9	Analogue 9 Page	06318
AnOp10.OP	Analogue operator OP10	Analogue 10 Page	06338
AnOp11.OP	Analogue operator OP11	Analogue 11 Page	06358
AnOp12.OP	Analogue operator OP12	Analogue 12 Page	06378
AnOp13.OP	Analogue operator OP13	Analogue 13 Page	06398
AnOp14.OP	Analogue operator OP14	Analogue 14 Page	06418
AnOp15.OP	Analogue operator OP15	Analogue 15 Page	06438
AnOp16.OP	Analogue operator OP16	Analogue 16 Page	06458
LgOp1.OP	Logic operator output 1	Chapter 15 LOGIC OPERS Logic 1 Page	07176
LgOp2.OP	Logic operator output 2	Logic 2 Page	07192
LgOp3.OP	Logic operator output 3	Logic 3 Page	07208
LgOp4.OP	Logic operator output 4	Logic 4 Page	07224
LgOp5.OP	Logic operator output 5	Logic 5 Page	07240
LgOp6.OP	Logic operator output 6	Logic 6 Page	07256
LgOp7.OP	Logic operator output 7	Logic 7 Page	07272
LgOp8.OP	Logic operator output 8	Logic 8 Page	07288
LgOp9.OP	Logic operator output 9	Logic 9 Page	07304
LgOp10.OP	Logic operator output 10	Logic 10 Page	07320
LgOp11.OP	Logic operator output 11	Logic 11 Page	07336
LgOp12.OP	Logic operator output 12	Logic 12 Page	07352
LgOp13.OP	Logic operator output 13	Logic 13 Page	07368
LgOp14.OP	Logic operator output 14	Logic 14 Page	07384
LgOp15.OP	Logic operator output 15	Logic 15 Page	07400
LgOp16.OP	Logic operator output 16	Logic 16 Page	07416

Clk.Alm1	Timer alarm 1	Chapter 12 TIMER BLOCKS Alarm 1 Page	08711
Clk.Alm2	Timer alarm 2	Alarm 2 Page	08716
Tot1.Alm	Totaliser 1 alarm output	Chapter 12 TIMER BLOCKS Totaliser 1 Page	08743
Tot2.Alm	Totaliser 2 alarm output	Totaliser 2 Page	08757
Tot3.Alm	Totaliser 3 alarm output	Totaliser 3 Page	08775

Tot4.Alm	Totaliser 4 alarm output	Totaliser 4 Page	08791
Tmr1.OP	Timer 1 output	Chapter 12 TIMER BLOCKS Timer 1 Page Timer 2 Page Timer 3 Page Timer 4 Page	08963
Tmr2.OP	Timer 2 output		08975
Tmr3.OP	Timer 3 output		08987
Tmr4.OP	Timer 4 output		08999
UVal1.Val	User 1 value	Chapter 13 USER VALUES User Val 1 Page User Val 2 Page User Val 3 Page User Val 4 Page	09220
UVal2.Val	User 2 value		09225
UVal3.Val	User 3 value		09230
UVal4.Val	User 4 value		09235
Pat1.OP1	Pattern 1 output 1	Chapter 15 PATTERN GENERATOR Dig Group 1	09973
Pat1.OP2	Pattern 1 output 2		09974
Pat1.OP3	Pattern 1 output 3		09975
Pat1.OP4	Pattern 1 output 4		09976
Pat1.OP5	Pattern 1 output 5		09977
Pat1.OP6	Pattern 1 output 6		09978
Pat1.OP7	Pattern 1 output 7		09979
Pat1.OP8	Pattern 1 output 8		09980
Pat1.OP9	Pattern 1 output 9		09981
Pat1.OP10	Pattern 1 output 10		09982
Pat1.OP11	Pattern 1 output 11		09983
Pat1.OP12	Pattern 1 output 12		09984
Pat1.OP13	Pattern 1 output 13		09985
Pat1.OP14	Pattern 1 output 14		09986
Pat1.OP15	Pattern 1 output 15		09987
Pat1.OP16	Pattern 1 output 16		09988
Pat2.OP1	Pattern 2 output 1	Chapter 15 PATTERN GENERATOR Dig Group 2	10037
Pat2.OP2	Pattern 2 output 2		10038
Pat2.OP3	Pattern 2 output 3		10039
Pat2.OP4	Pattern 2 output 4		10040
Pat2.OP5	Pattern 2 output 5		10041
Pat2.OP6	Pattern 2 output 6		10042
Pat2.OP7	Pattern 2 output 7		10043
Pat2.OP8	Pattern 2 output 8		10044
Pat2.OP9	Pattern 2 output 9		10045
Pat2.OP10	Pattern 2 output 10		10046
Pat2.OP11	Pattern 2 output 11		10047
Pat2.OP12	Pattern 2 output 12		10048
Pat2.OP13	Pattern 2 output 13		10049
Pat2.OP14	Pattern 2 output 14		10050
Pat2.OP15	Pattern 2 output 15		10051
Pat2.OP16	Pattern 2 output 16		10052
Sum.LP2&3	Summary of loop 2 and loop3		10246
Sum.PrName	Summary of programmer name	Chapter 6 PROGRAM RUN General Page	10247
Sum.D1-16	Summary of digital outputs 1 to 16	Chapter 6 PROGRAM RUN General Page	10248
Sum.TiRem	Summary of program time remaining	Chapter 6 PROGRAM RUN General Page	10249
Const.1	Constant value = 1 May be used in place of a User Value		10464
Zirc.PV	Zirconia Value	Chapter 10 ZIRCONIA PROBE Options Page	11059
Zirc.Stat,	Probe Status		11066
Zirc.Clea	Clean State		11067
Zirc.SAlm	Sooting Alarm		11068

Humid.%RH	Relative Humidity	Chapter 10 HUMIDITY Options Page	11105
Humid.DwP	Dewpoint	Chapter 10 HUMIDITY Options Page	11106
DI8.Val	Status of digital input 8	Chapter 17 STANDARD IO Diagnostic Page	11313
DI-E1.Val	Status of IO expander inputs		11314
L1Alm1.OP	Loop1 alarm 1 output	Chapter 7 ALARMS LP1 Page	11592
L1Alm2.OP	Loop1 alarm 2 output	LP1 Page	11602
L2Alm1.OP	Loop2 alarm 1 output	LP2 Page	11640
L2Alm2.OP	Loop2 alarm 2 output	LP2 Page	11650
L3Alm1.OP	Loop3 alarm 1 output	LP3 Page	11688
L3Alm2.OP	Loop3 alarm 2 output	LP3 Page	11698
U1Alm.OP	User 1 alarm output	User 1 Page	11737
U2Alm.OP	User 2 alarm output	User 2 Page	11753
U3Alm.OP	User 3 alarm output	User 3 Page	11769
U4Alm.OP	User 4 alarm output	User 4 Page	11785
U5Alm.OP	User 5 alarm output	User 5 Page	11801
U6Alm.OP	User 6 alarm output	User 6 Page	11817
U7Alm.OP	User 7 alarm output	User 7 Page	11833
U8Alm.OP	User 8 alarm output	User 8 Page	11849
NewAlarm	New alarm	Summary Page	12162
IOEx.IP1	IO expander input 1		12187
IOEx.IP2	IO expander input 2		12188
IOEx.IP3	IO expander input 3		12189
IOEx.IP4	IO expander input 4		12190
IOEx.IP5	IO expander input 5		12191
IOEx.IP6	IO expander input 6		12192
IOEx.IP7	IO expander input 7		12193
IOEx.IP8	IO expander input 8		12194
IOEx.IP9	IO expander input 9		12195
IOEx.IP10	IO expander input 10		12196

30.2 PARAMETER UNITS

PSP Units are:-

None

°C/°F/°K,

V, mV, A, mA,

PH, mmHg, psi, bar, mbar, %RH, %, mmWG, inWG, inWW, Ohms, PSIG, %O2, PPM, %CO2, %CP, %/sec,

°C°F°K(rel),

Custom 1, Custom 2, Custom 3, Custom 4, Custom 5, Custom 6,

sec, min, hrs,

30.3 MODULE STATUS MESSAGES

OK	Module good
Initialising	Module initialising
Ch A SBreak	Channel A sensor input break
Ch C SBreak	Channel C sensor input break
Ch A Out Range	Channel A out of range
Ch C Out Range	Channel C out of range
Ch A IP Sat	Channel A input saturation
Ch C IP Sat	Channel C input saturation
Ch A Not Calib	Channel A not calibrated
Ch C Not Calib	Channel C not calibrated
Ch Short CCT	Channel terminals shorted

31.APPENDIX E CASCADE TRIM MODE - EARLIER CONTROLLERS

Controllers built after April 2001 with software versions 4.0 or greater use the cascade trim block diagram shown in Section 9.10.5.

Earlier versions used the block diagram shown below.

It is recommended that if this mode is required for your application that the controller should be upgraded to Version 4.0 or greater. These later versions use additional trim limits and scaling to provide improved control in this mode.

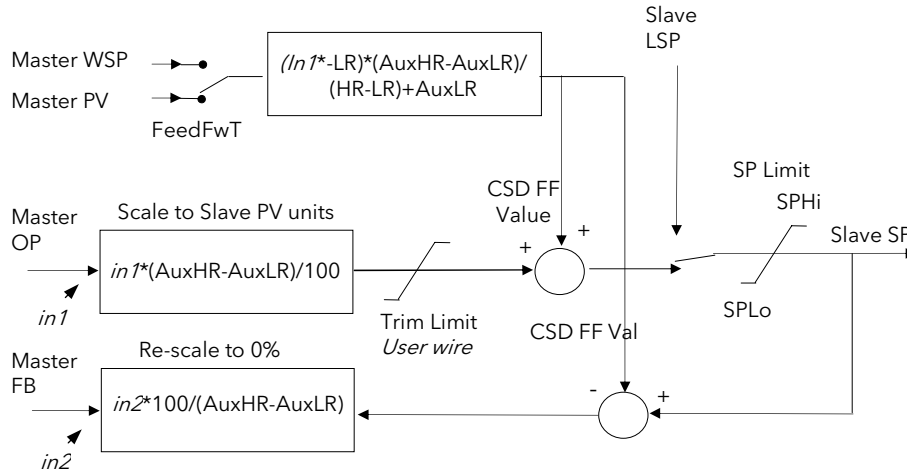


Figure 31-1: Cascade Trim Mode - Software Versions Earlier Than V4.0

31.1 CASCADE PARAMETERS

Table Number: E.1. These parameters allow you to autotune the loop		LPx setup (Cascade Page)		
Parameter Name	Parameter Description	Value	Default	Access Level
Disable CSD	Cascade disable status. (It is sometimes useful to disable cascade when starting a process. This also returns the controller to single loop control using the local SP.)	Off On		L1
CSD FF Value	Cascade feedforward value i.e. The value being fed forward	Range of signal being fed forward		L3
CSD FF Trim Lim	Cascade feedforward trim limit i.e. The amount the master output can be trimmed up and down	Range of slave loop		L3
Work FF Value	Working feedforward value			R/O
The above three parameters only appear if 'FF Type' ≠ 'None'				
Master OP	Cascade master PID output power	Range of slave loop	R/O	

32. DECLARATION OF CONFORMITY



Declaration of Conformity	
Manufacturer:	Eurotherm Limited Faraday Close, Worthing, West Sussex, BN13 3PL, United Kingdom
Product type:	Contoller/Programmer
Models:	2604 Controller 2604f Controller 2704 Controller 2704f Controller 2000IO Digital I/O expander
Safety specification:	EN61010-1: 2001
EMC emissions specification:	EN61326-1: 2006 (Class B) (Ethernet/Devicenet options: Class A)
EMC immunity specification:	EN61326-1: 2006 Industrial Locations

Eurotherm Limited hereby declares that the above products conform to the safety and EMC specifications listed. Eurotherm Limited further declares that the above products comply with the EMC Directive 2004/108/EC, and also with the Low Voltage Directive 2006/95/EC.

Signed: Kevin Shaw Dated: 16th Aug 2011
Signed for and on behalf of Eurotherm Limited.
Kevin Shaw
(R&D Director)

UA249986/510 Issue 4 Aug 11 (CN27403)



Eurotherm: International sales and support www.eurotherm.com

Contact Information

Eurotherm Head Office

Faraday Close,
Durrington,
Worthing, West Sussex,
BN13 3PL

Sales Enquiries

T +44 (01903) 695888
F 0845 130 9936

General Enquiries

T +44 (01903) 268500
F 0845 265982

Worldwide Offices

www.eurotherm.com/global



Scan for local contacts



©Copyright Invensys Eurotherm Limited 2013

Invensys, Eurotherm, the Eurotherm logo, Chessell, EurothermSuite, Mini8, Eycon, Eyris, EPower, EPack nanodac, piccolo, Foxboro, and Wonderware are trademarks of Invensys plc, its subsidiaries and affiliates. All other brands may be trademarks of their respective owners.

All rights are strictly reserved. No part of this document may be reproduced, modified or transmitted in any form by any means, neither may it be stored in a retrieval system other than for the purpose to act as an aid in operating the equipment to which the document relates, without the prior written permission of Invensys Eurotherm Limited.

Eurotherm Limited pursues a policy of continuous development and product improvement. The specifications in this document may therefore be changed without notice. The information in this document is given in good faith, but is intended for guidance only.

Eurotherm Limited will accept no responsibility for any losses arising from errors in this document.

i n v e n s y s
Operations Management