



ENVIROBUILD

**Balcony & Terrace
Surface Finish Systems**



Call us at any point

Take the stress off; the experts at EnviroBuild can assist you with **any part of your project**, so please don't hesitate to give us a call.

We can help with anything from **drawings** and **takeoffs** to offering **site visits** or a **showroom tour**.

+44 (0) 203 959 1220

Our service

Here are just a few of the things we can offer you while working with EnviroBuild.



Site visits



CPDs



Showroom



Drawings



Takeoffs

Contents

Surface Finishes	4
Aluminium Decking & Cladding	4
Porcelain Paving	8
Fibre Cement Decking	10
Composite Decking	12
Floating Floor Systems	14
Flat Roof Decking	14
Open Steel	15
Sloped Open Steel	16
Flat Roof Paving	17
Paving on Steel Balconies	18
Paving with Wind-Uplift Clips	19
Systems Detail	20
Paving Wind-Uplift Adhesive	20
Paving Wind-Uplift & Drainage Trays	21
Decking Drainage	22
Soffit System	24
Edging Detail	26
Non-Combustible Support Pedestals	27
Further Information	28
Aluminium Powder Coating	28
Specifications	29
Miscellaneous	40
The Green Option	40
Our Service	41
Our Clients	42

Aluminium Decking



Fire Resistant
A-Class to EN 13501-1



Qualicoat
Certified powder coat



Legally Compliant
Adheres to BS:8579



-  7016
-  8019

Low-Fix

 800 mm span

 Drainage solutions

 Direct fix



-  7016



Strong-Span

 1200 mm span

 Drainage solutions

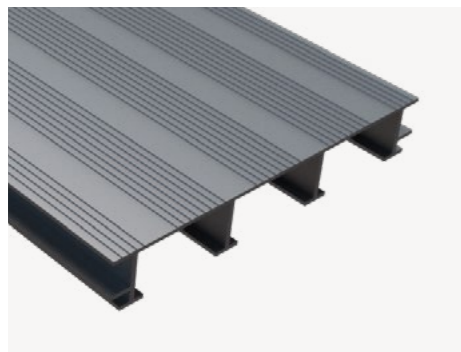
 Direct fix



-  7016
-  7037
-  8019
-  8014

Pro-Grip

 Lowest slip potential

 Lowest price

 Great for terraces

 Bespoke RAL colours available upon request

Technical sheets, pg. 32-35

Case Studies

Latham's Yard

Our Aqua-Channel Aluminium Decking was chosen for this balcony refurb as it's easy to install and has an A-Class fire resistance rating. These deck boards are low-slip and feature a passive drainage system that allows for management of water runoff.



Newfoundwell Project

This high-quality housing development comprises of 92 residential units located on Newfoundwell Road, Drogheda. Strong-Span aluminium decking boards were chosen for this project for their ease of installation to steel beams.



Aluminium Decking (Cont.)



Fire Resistant
A-Class to EN 13501-1



Qualicoat
Certified powder coat



Legally Compliant
Adheres to BS:8579

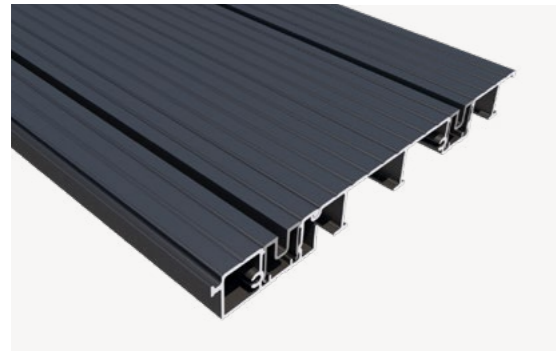

7016

8019

Aqua-Channel

- Built-in drainage system
- Continuous surface
- Direct fix



7016

8019

Cladding

- Easy-install shiplap facade
- Drainage solutions
- Works as soffit boards

See soffit boards on page 24

Bespoke RAL colours available upon request

Technical sheets, pg. 31-33

Case Studies

Bomore Road

The redevelopment of 1 Bomore Road, located in Kensington London, involved the removal of outdated wooden planks to be redesigned and fitted with high quality non-combustible Pro Grip aluminium decking.

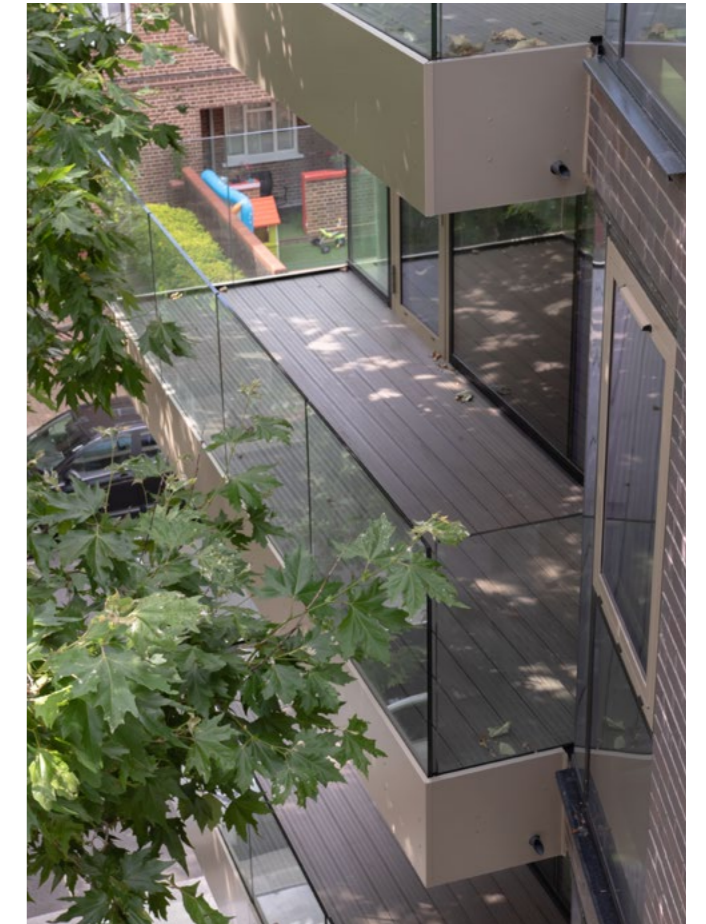

Ensign Court

Pro-Grip aluminium decking was used to furnish the 520 m² of balcony and terrace areas on this build due to being compliant with the latest fire safety laws. The project also utilised fire-rated edging, joists, pedestals and screws.

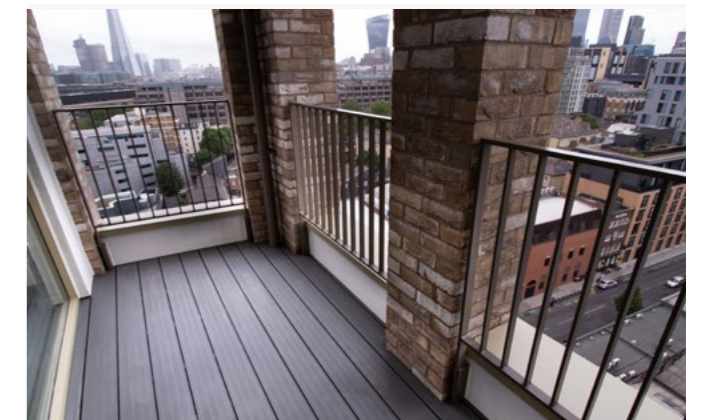

Porcelain Paving



Fire Resistant
A-Class to EN 13501-1



Durable
No scratches or stains



No Sun Fading
Exposure protected



Stone Effect

↔ 600x600 mm

🌀 High definition stone design

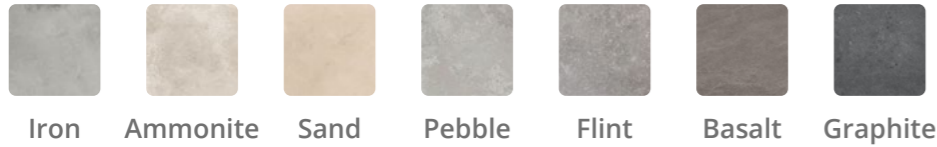

More colours and sizes are available on request



Wood Effect

↔ 1200x300 mm

🌀 Authentic wood texture

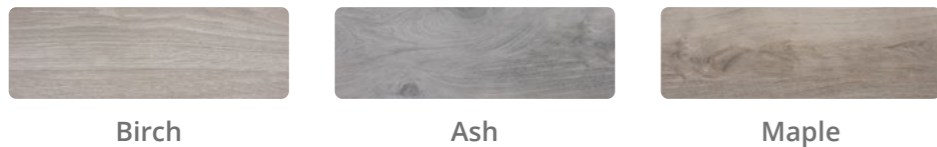

Wind-uplift on steels, pg. 18
Technical sheets, pg. 36-37

Case Studies

Park Heights Rooftop

Park Heights is a prime project at the forefront of Network Homes' transformation of the Stockwell Park Estate. Comprising of 159 high-quality apartments with private balconies, a sky garden and communal terraces across its 20 storeys.

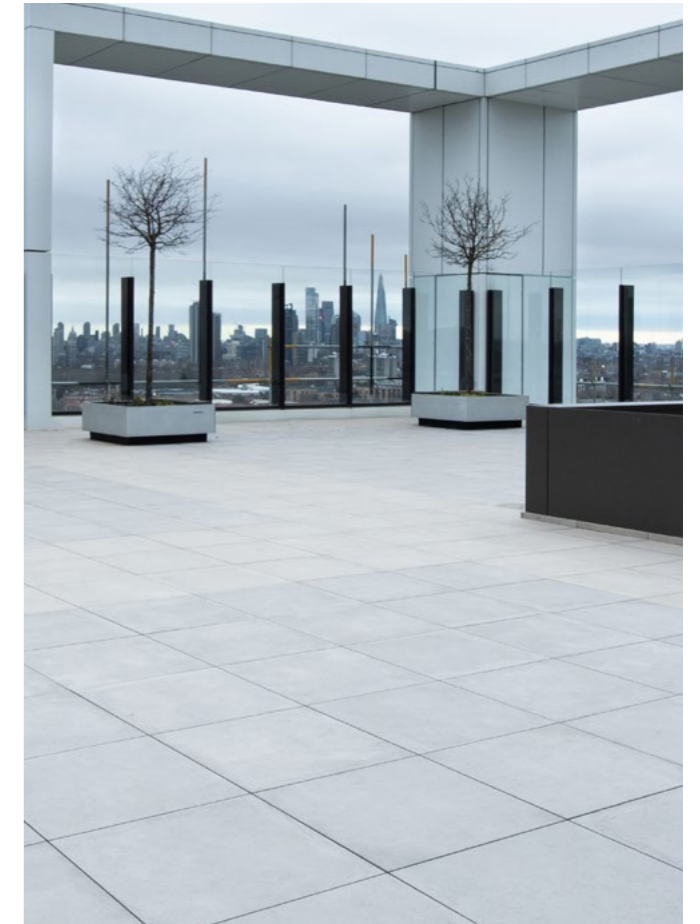

Bomore Road Balconies

1 Bomore Road needed external flooring materials that would suit the existing clean creative of the project plans and comply with contemporary construction requirements, contributing to its unique architectural mix of harshness and harmony.



Fibre Cement Decking



Fire Resistant
A-Class to EN 13501-1



Durable
Anti-rot & anti-decay



Moisture Resistant
No mould or mildew



Fibre Cement Decking

Easy to install and with a stunningly realistic wood finish, it's a must-have for balconies and terraces. The perfect way to enjoy the beauty of wood hassle-free whilst complying with fire safety regulations.

 **Embossed pattern**



Cloud

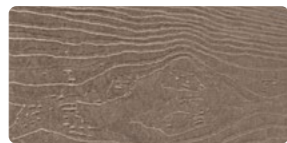

Coffee

Case Study

Elm Park

Elm Park's 535 m² project features apartments with dual balconies, supported by a non-combustible substructure of steel pedestals and aluminium joists. The use of Fibre Cement decking in Cloud enhances both the safety and aesthetics of the units.



Gallery

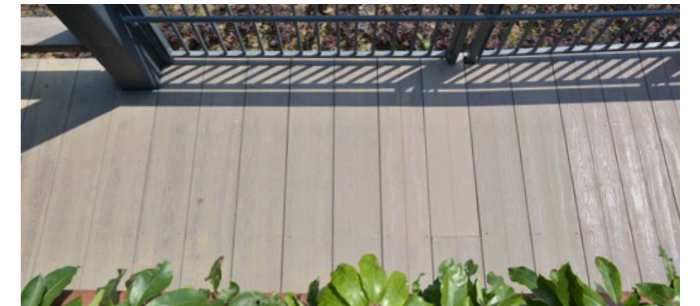

Technical sheets, pg. 38

Composite Decking



Low Maintenance
Easy to care for



Durable
Anti-rot & anti-splinter



Long-lasting
Up to 25 years warranty



Explorer Decking

Designed using the latest technology for a realistic wood-grain texture. The enhanced durability of this dimensional low-maintenance decking solution enables protection against stains and scratches.

Natural embossed pattern



Walnut

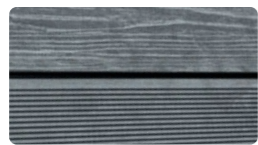

Stone

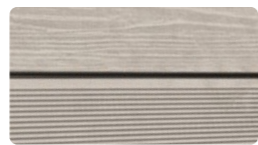

Silver Birch



Oak

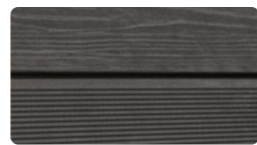

Granite

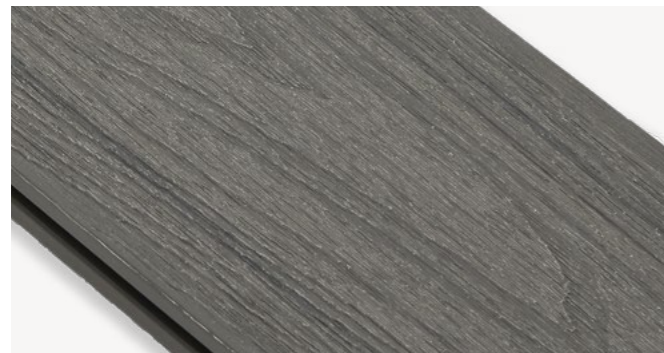

Frontier Decking

Engineered almost entirely from recycled material, this high performance decking includes enhanced fade, stain and mark protection, along with our anti-slip and splinter technology.

Shield protection technology



Iroko



Marble



Teak



Slate

[Technical sheets, pg. 39](#)

Case Study

Clockwork Building

The client was looking for a low maintenance alternative to timber decking on their 480 m² London office space refurbishment project. From design to delivery, the client received the full commercial support required to complete the job on schedule.

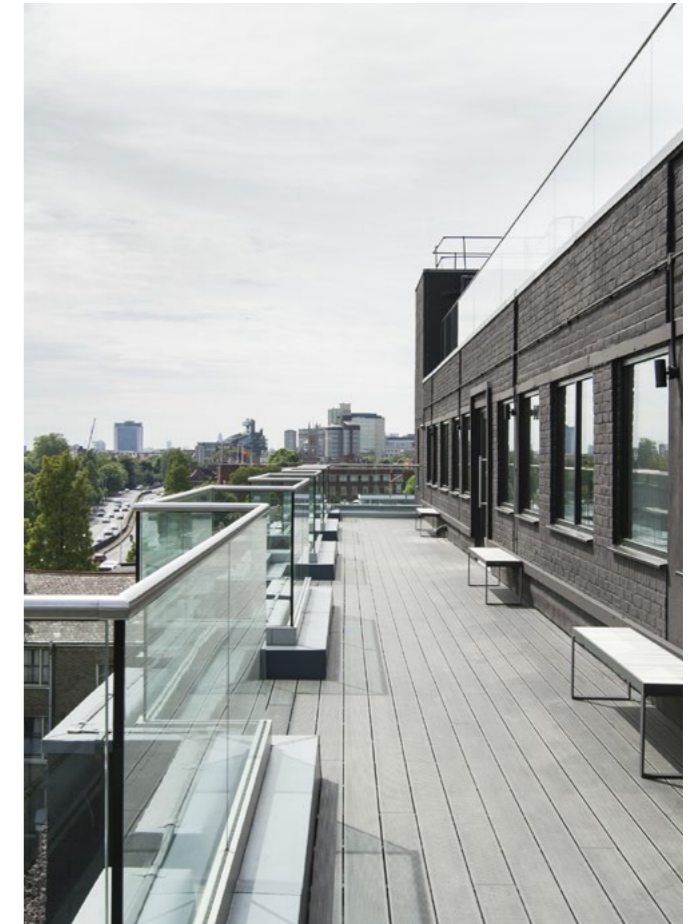

We also sell...



Composite Cladding

Pictured: Belvoir Vue, Belvoir Valley, *(Stone Pioneer)*

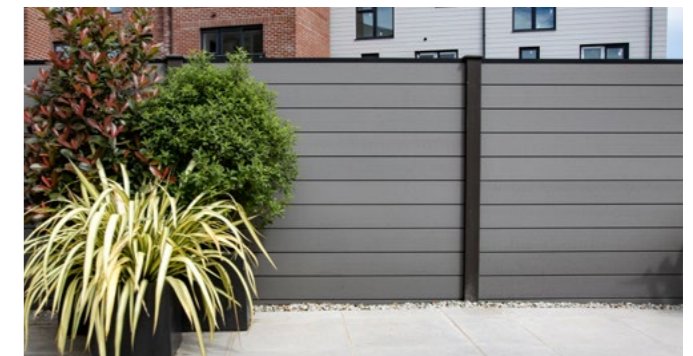

Composite Fencing

Pictured: Taw Wharf, Barnstaple, *(Stone Pioneer)*

Flat Roof Decking

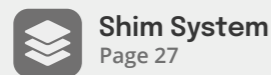
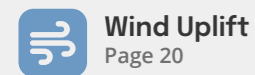
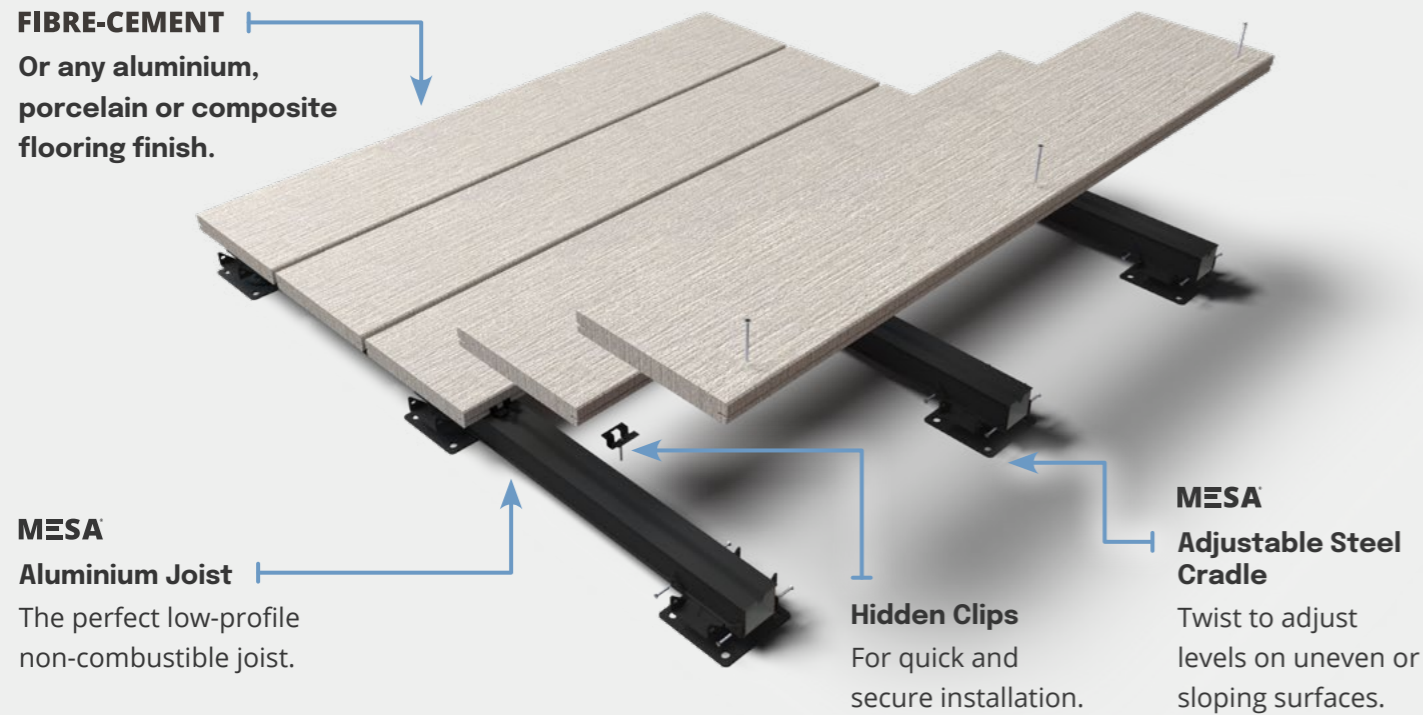

Easily adjustable heights for creating flat systems

Designed to meet the needs of a wide variety of both commercial and residential spaces this non-combustible fire rated system uses adjustable steel pedestals, aluminium joists and protective rubber membranes to provide security, strength and adaptability where it is needed most.

Substructure Detail

Height	28-503 mm
Weight	~11-19 kg/m ²
Suitable For	Balconies, terraces, lightweight areas

Works with

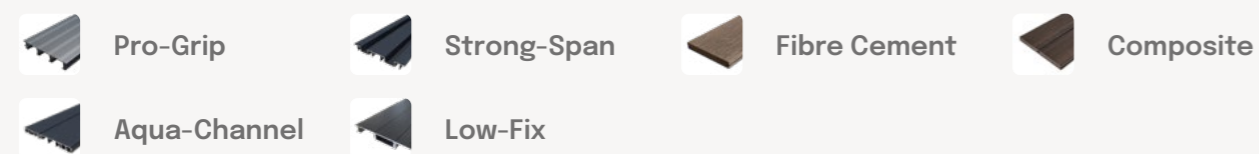

Open Steel

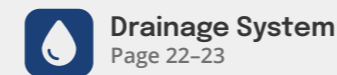
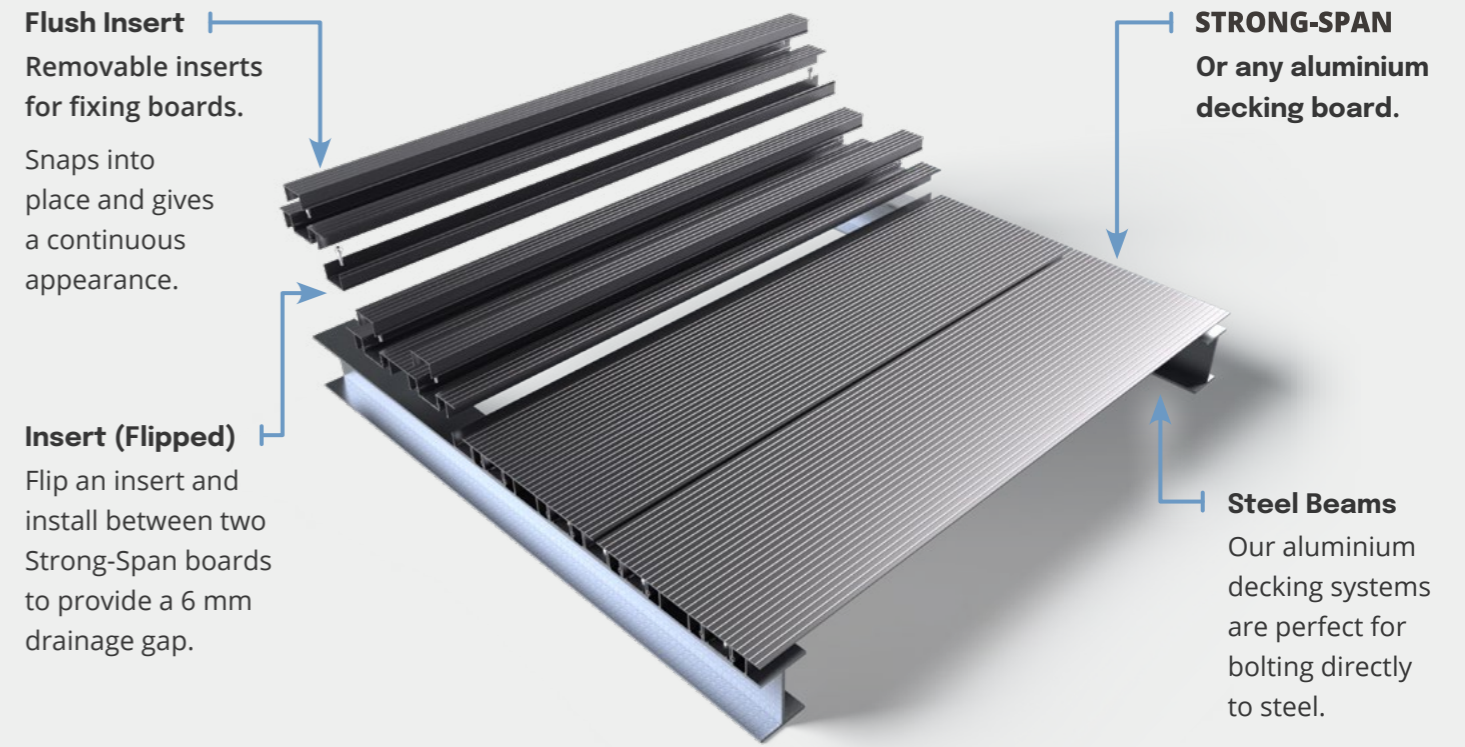

The lightweight time-saving steel beam balcony solution

A simple clip system can be attached to aluminium joists or steel up to 3 mm thick. These clips both hold the boards down and act as spacers for speedy installation. Single boards can be removed easily when craning a balcony.

Substructure Detail

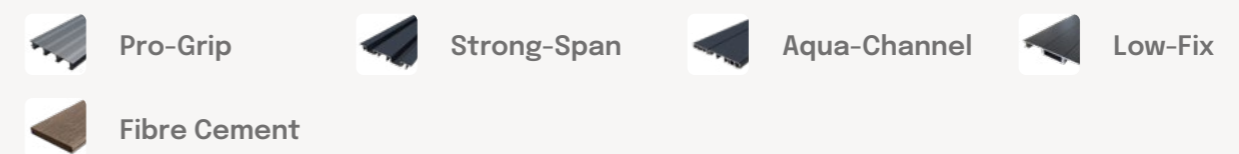

Tolerance	Max +/- 2 mm
Suitable For	Balconies and terraces with steel beam support

Works with

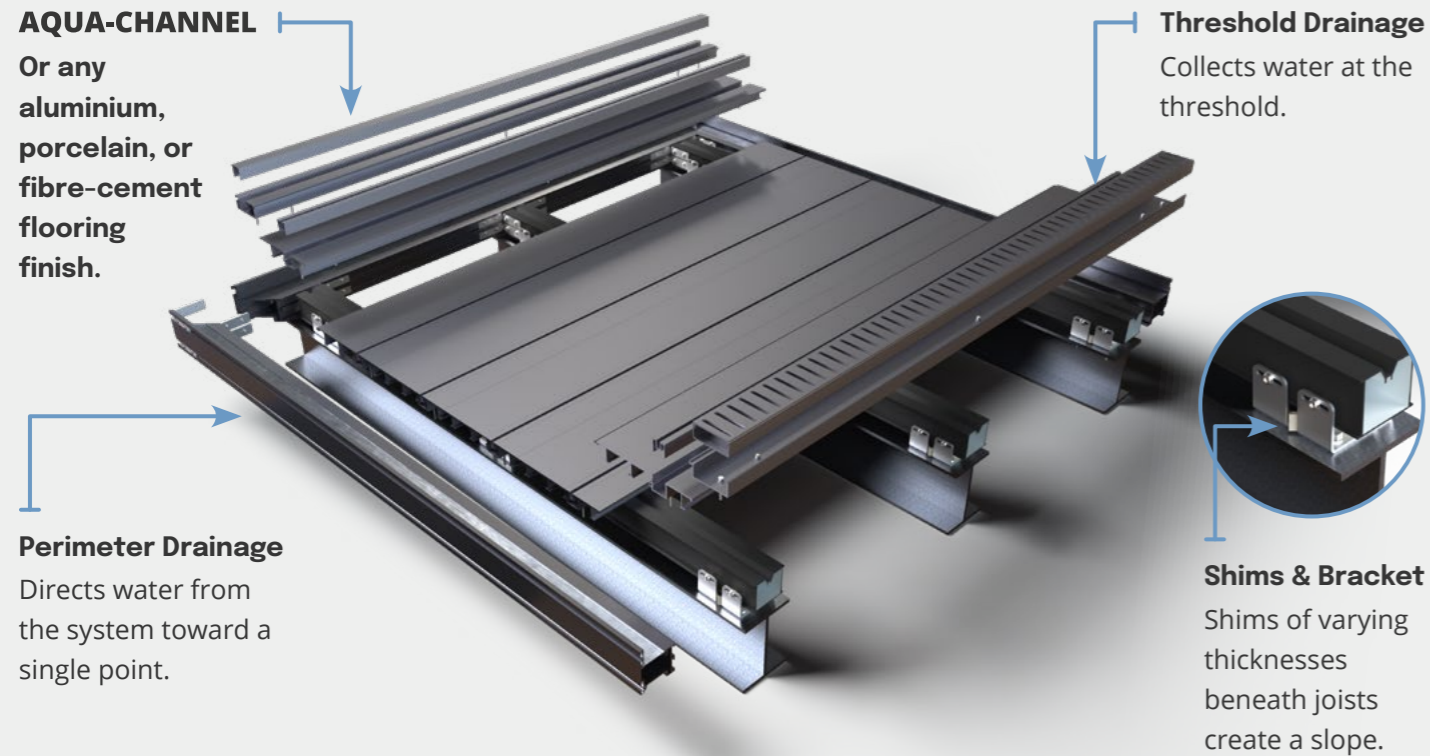

Sloped Open Steel



-  **Drainage System**
Page 22
-  **Wind Uplift**
Page 20
-  **Shim System**
Page 27

Shim system for ultra-low heights

This shim system is designed to provide a great level of control over the build-up height and the drainage slope. Shims of varying thicknesses are layered beneath joists to create a slope and are held in place using joist hangers screwed into the steel beams.

Substructure Detail

Suitable For Full drainage solutions

Works with

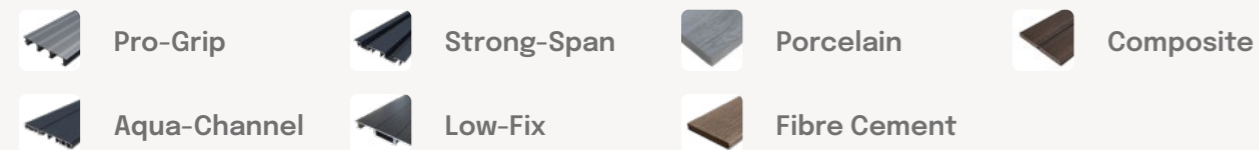

Flat Roof Paving

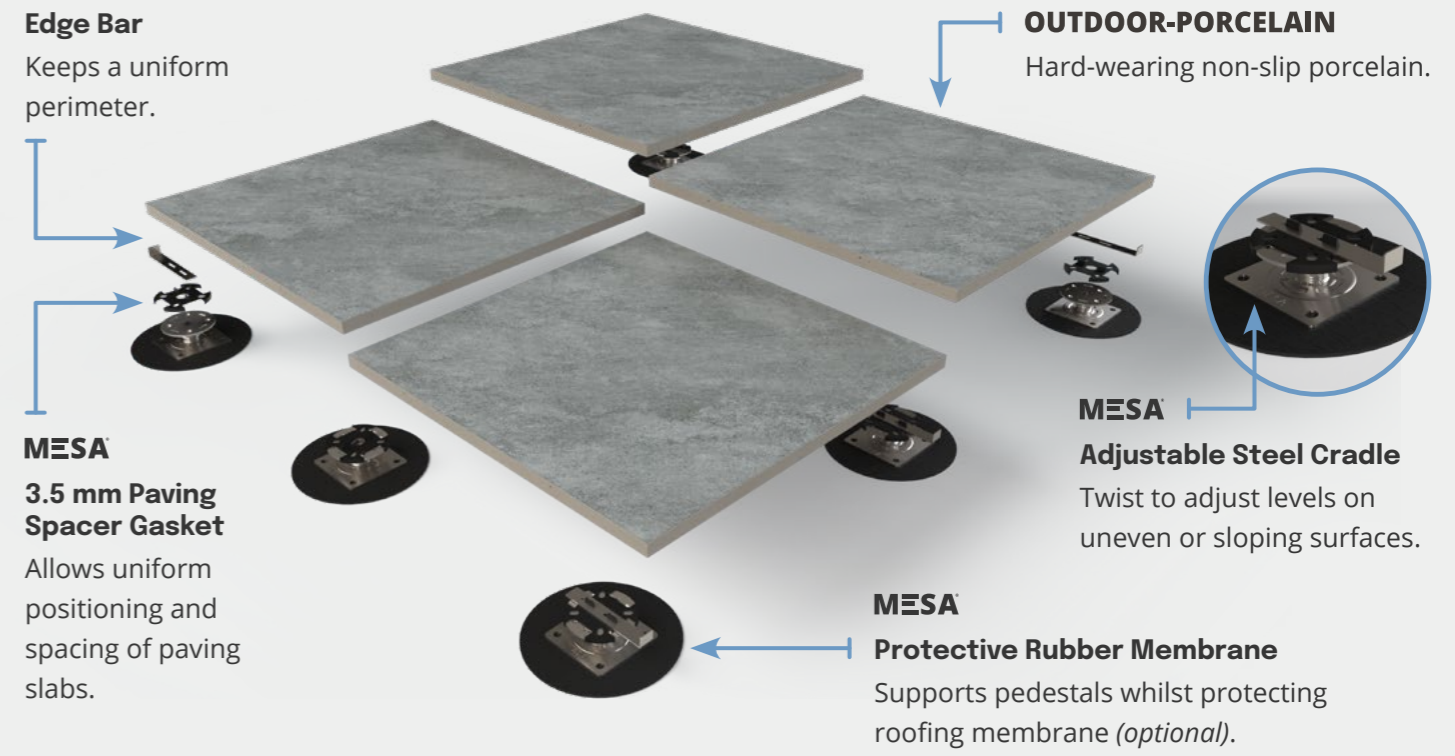

-  **Pedestal System**
Page 27

Fast and secure installation with uniform positioning

This system uses gaskets with adjustable steel pedestals and slip-proof rubber membranes to provide security, strength and adaptability where it is needed most. Paving spacer gaskets and edge bars ensure perfect spacing between slabs and at the perimeter.

Substructure Detail

Height	25-506 mm
Suitable For	Any surfaced area

Works with

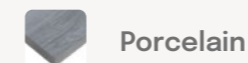

*Porcelain can also work with System 1 on rails

Paving on Steel Balconies

OUTDOOR-PORCELAIN
Or any aluminium, fibre-cement or composite flooring finish.



MESA Adhesive Glue

A thin layer is applied to the steel trays to prevent wind-uplift.

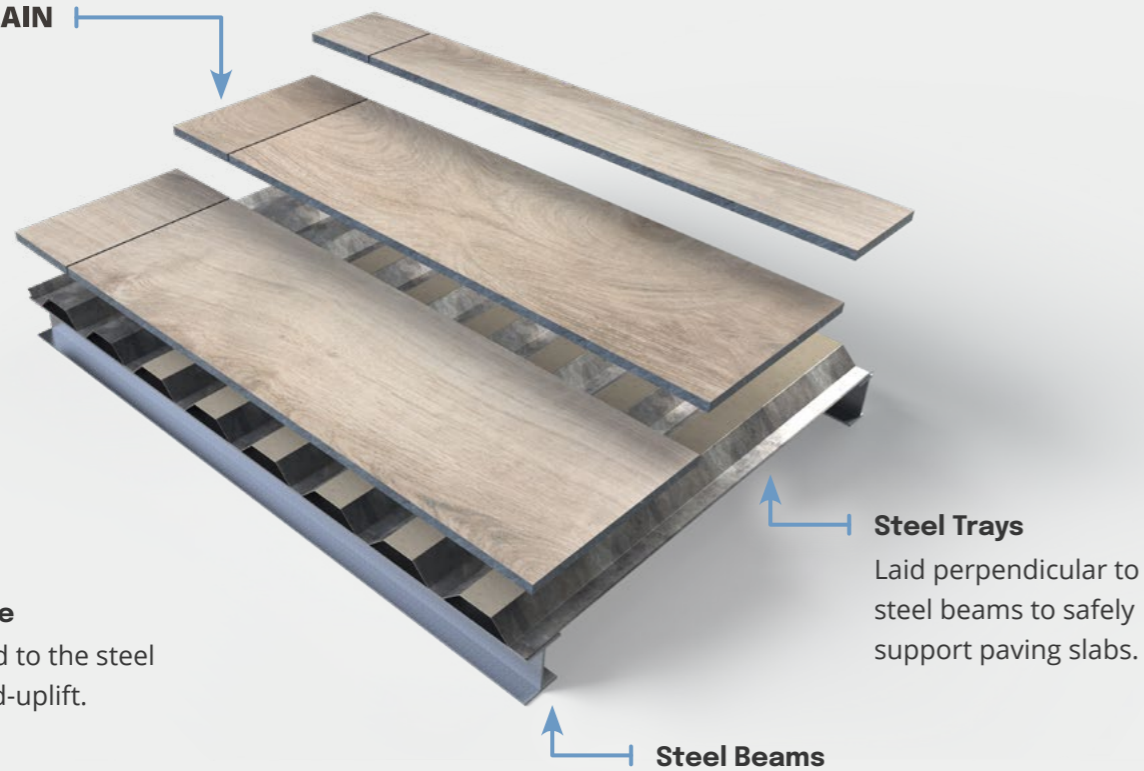

Steel Trays
Laid perpendicular to steel beams to safely support paving slabs.

Steel Beams
This system makes laying porcelain on steel beam balconies possible.

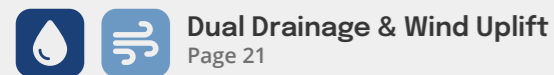

A simple adhesion for avoiding wind-uplift of paving slabs

Non-Combustible Adhesive by MESA is an A2 fire rated epoxy adhesive. The adhesive holds the paving slabs to the joists beneath, preventing the uprooting of slabs in the event of very strong winds.

Substructure Detail

Height	Min. 87 mm
Suitable For	Balconies and terraces with steel beam support

Works with

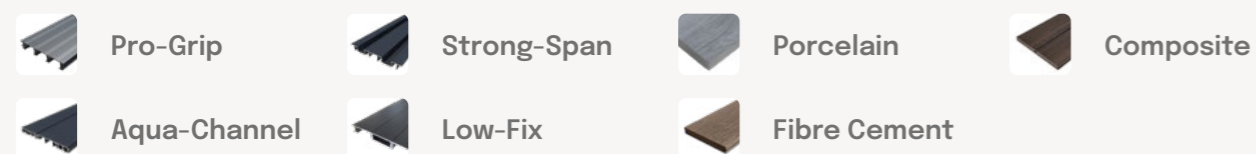

Paving Wind-Uplift Clips

OUTDOOR-PORCELAIN
Paving or Decking Porcelain available.

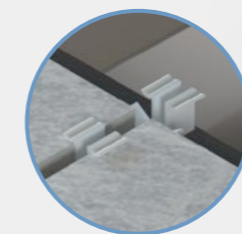

Wind-uplift Clip

A thin layer is applied to the steel trays to prevent wind-uplift.

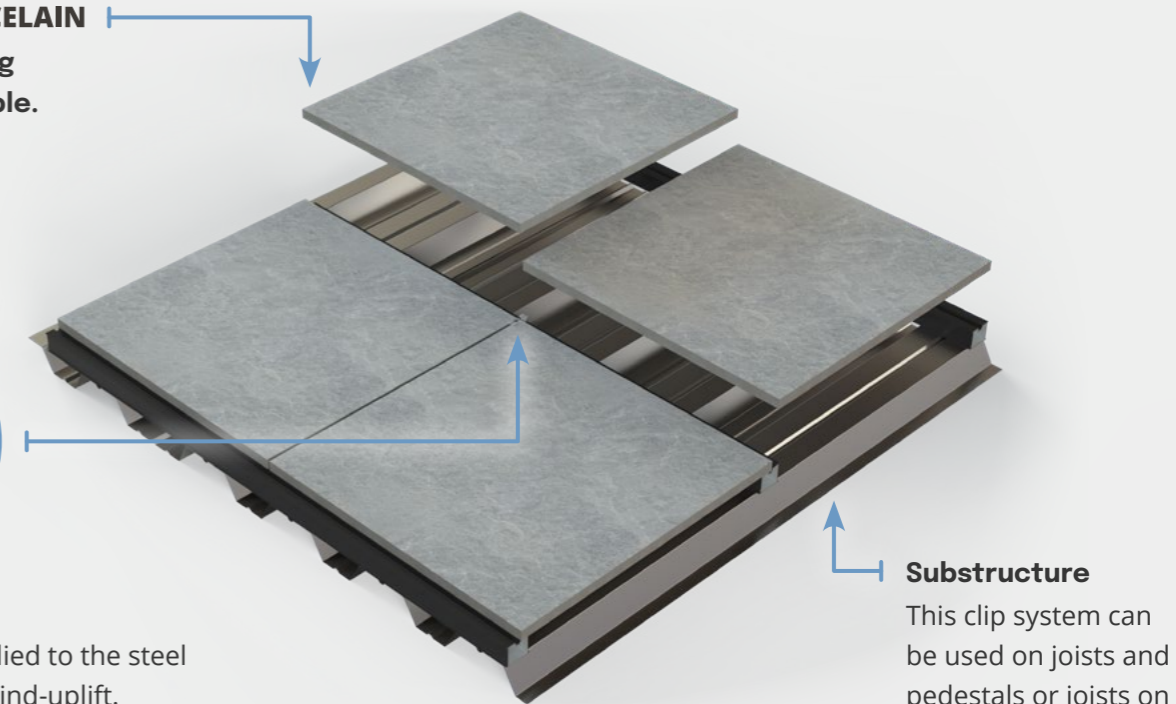

Substructure
This clip system can be used on joists and pedestals or joists on steel trays.

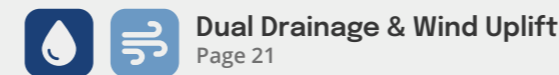

A simple clip system for avoiding wind-uplift of paving slabs

Wind-uplift clips have four arms for holding each paving slab in place, with built-in spacer tabs. The clips are screwed into the joists below, keeping the slabs securely in place. This system also allows for the easy removal of individual slabs.

Substructure Detail

Height	Min. 107 mm
Suitable For	Balconies and terraces with steel beam support

Works with

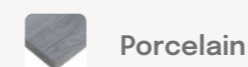

Wind-uplift Paving

Wind-uplift with adhesive

MESA Adhesive Glue

Non-Combustible Adhesive by MESA is an A2 fire rated epoxy adhesive. The adhesive holds the paving slabs to the joists beneath, preventing the uprooting of slabs in the event of very strong winds.

- MESA Non-Combustible Adhesive comes in 2 parts. These need to be mixed in order to activate.
- Part 1 and Part 2 should be mixed in a 1:1 ratio.
- The mixed adhesive should be applied to joists at a maximum thickness of 1 mm.
- Protective gloves/clothing/eye protection/face protection should be worn.

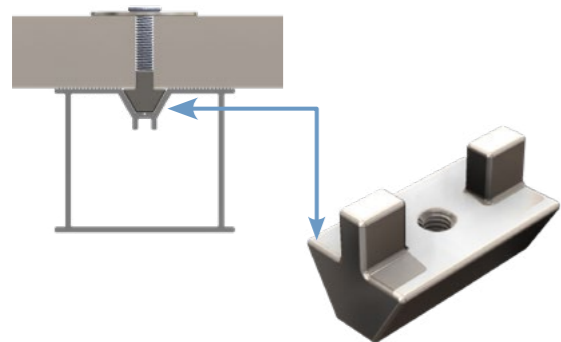

Quick removal of porcelain for service areas

- The clip slots into the aluminium joist.
- The paving slab is held between the clip and a screw and washer on the top surface.
- Used for paving installed above vital substructure components. Unscrew screws and lift the paving slab for access. Other paving slabs can be glued as usual.

Paving Trays

Dual wind-uplift and drainage

Adhesive trays prevent wind-uplift

- MESA Non-combustible Adhesive is spread between the steel trays and the porcelain paving, preventing the wind-uplift.
- Allows any sized porcelain to be used with open steel subframes.
- Steel trays can span 750 mm and work on all commercial balconies and terraces with steel beam support structures.
- For height flexibility, the trays can be used with joists and shims, or they can simply be laid directly to steel.

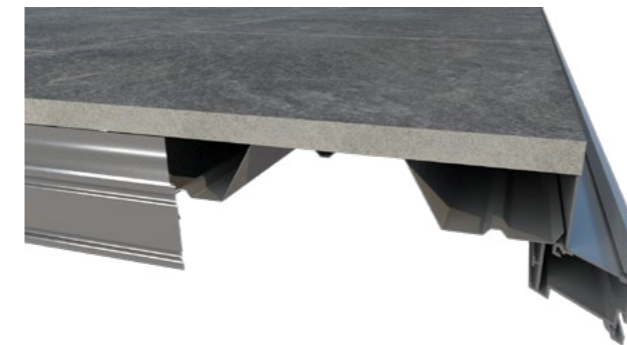
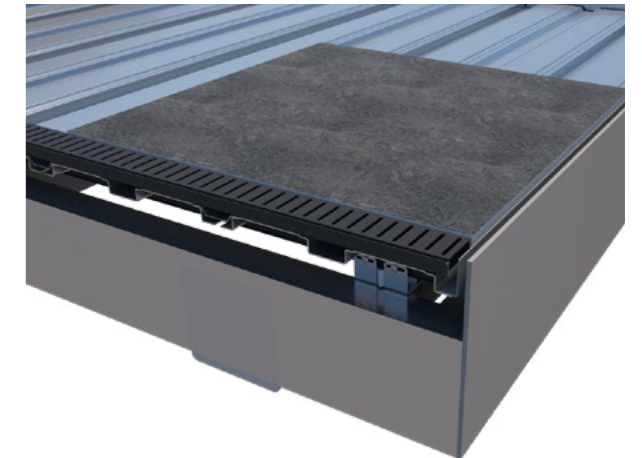

Optional drainage system

- A slope is created using joists, shim brackets and shims of differing heights.
- Steel trays are installed perpendicular to the joists and water can drain into the gaps between pavers and into these trays.
- Water then goes into the drainage perimeter where it collects and is directed to a single drainage point.

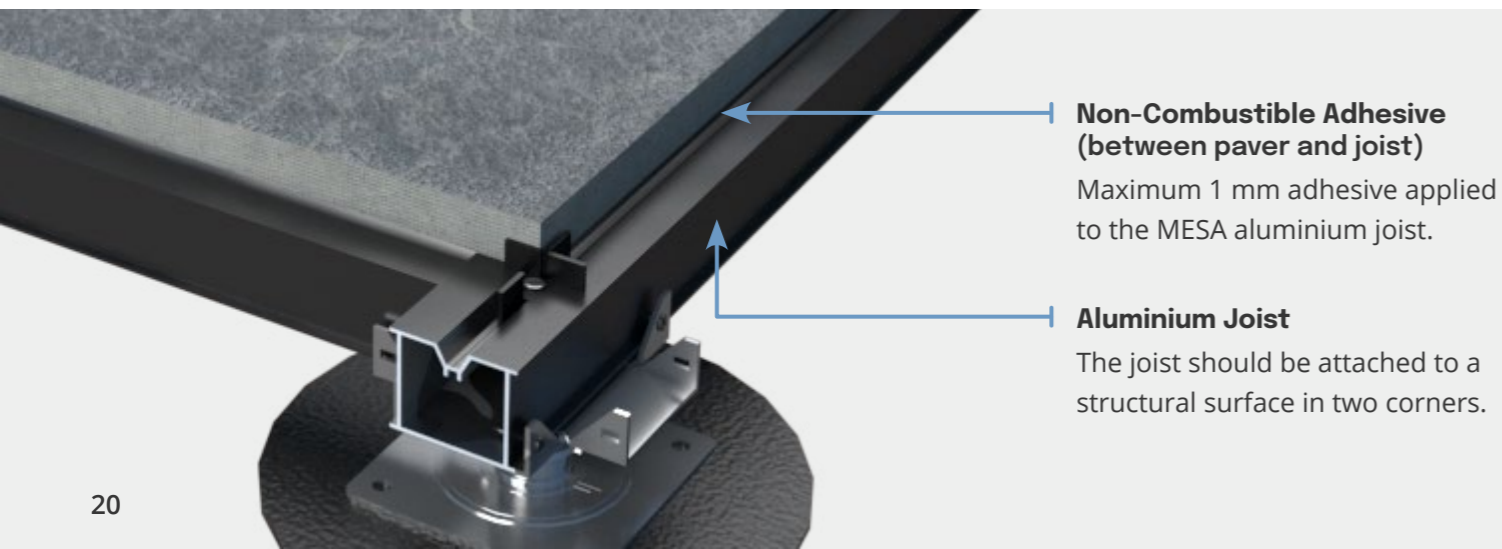

Non-Combustible Adhesive (between paver and joist)
Maximum 1 mm adhesive applied to the MESA aluminium joist.

Aluminium Joist
The joist should be attached to a structural surface in two corners.

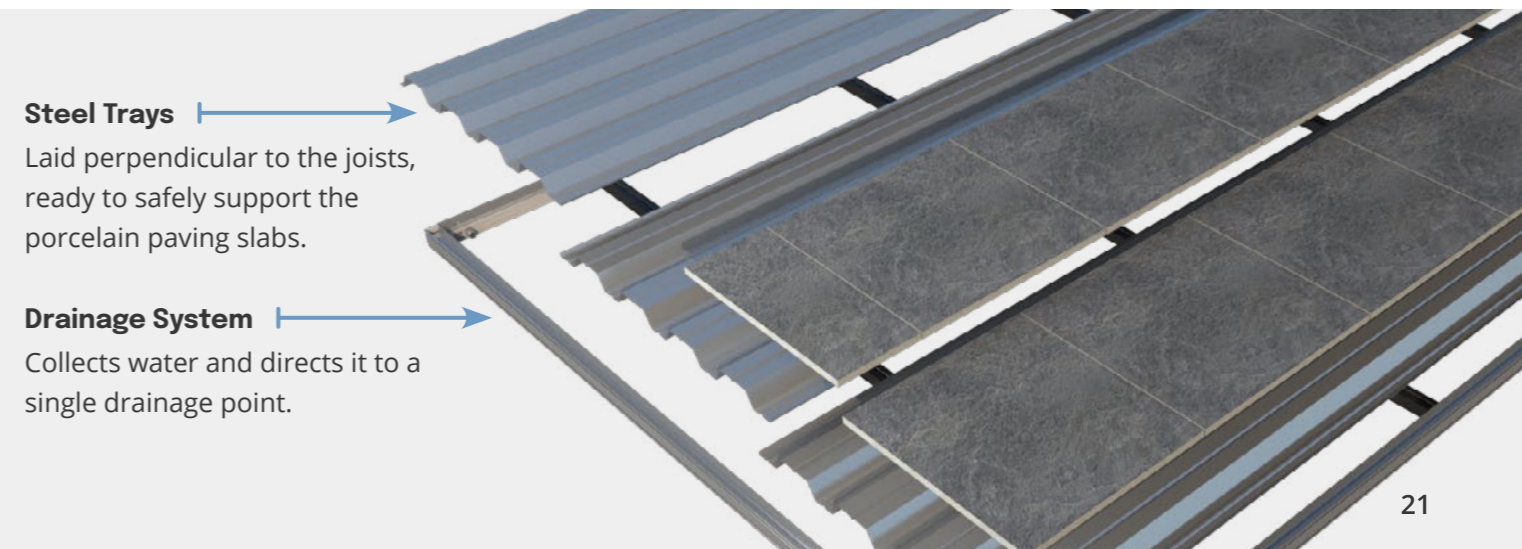

Steel Trays
Laid perpendicular to the joists, ready to safely support the porcelain paving slabs.

Drainage System
Collects water and directs it to a single drainage point.

Decking Drainage

Perimeter water-drainage

Creating bespoke slopes

To allow for drainage, EnviroBuild can provide a bespoke assembly with shims of varying thicknesses beneath joists in order to create slopes and to be compliant with BS 8579 regulations.

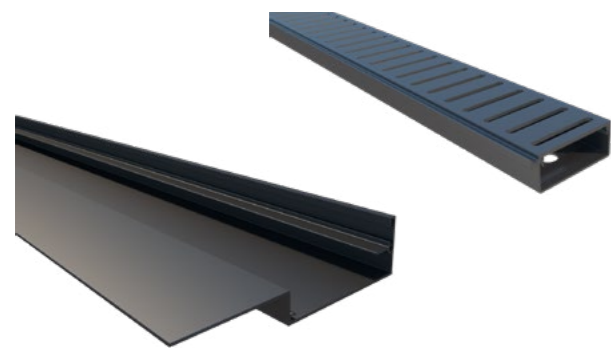

Built-in drainage system

- The threshold drainage piece is installed by the door.
- Water drains along the threshold drainage and into the perimeter drainage.
- Water is drained to a single point and out of the bottom of the balcony.

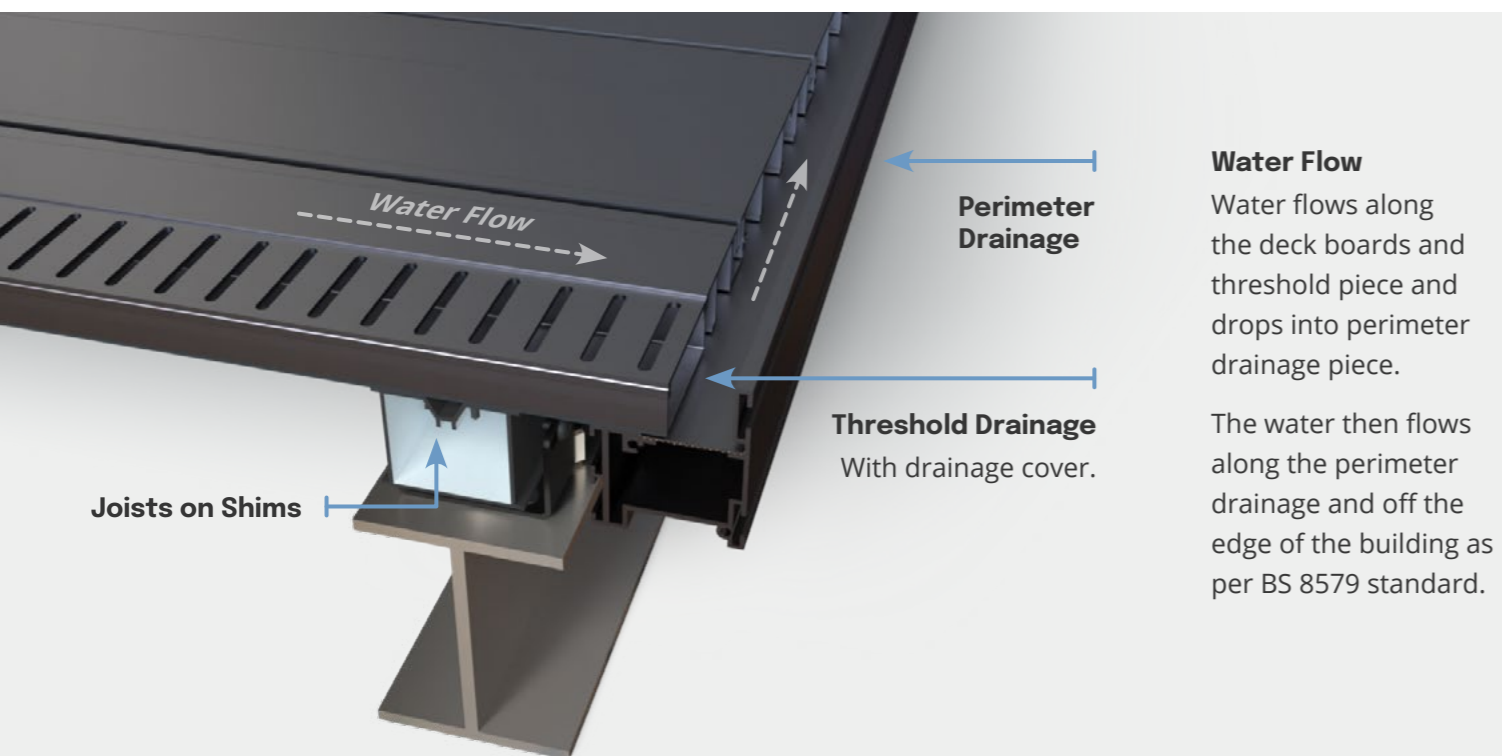

Water Flow

Water flows along the deck boards and threshold piece and drops into perimeter drainage piece.

The water then flows along the perimeter drainage and off the edge of the building as per BS 8579 standard.

Perimeter Drainage

Threshold Drainage
With drainage cover.

Joists on Shims

Decking Drainage

Hopper water-drainage

Collects water between board gaps

The hopper system works with Strong-Span and Low-Fix decking equipped with drainage inserts.

- Water runs from the deck board surface into the board gaps
- The drainage inserts collect the water and channel them toward the hopper.
- The hopper directs water to a final drainage point.
- This system allows for drainage in the middle of the system as well as the perimeter.

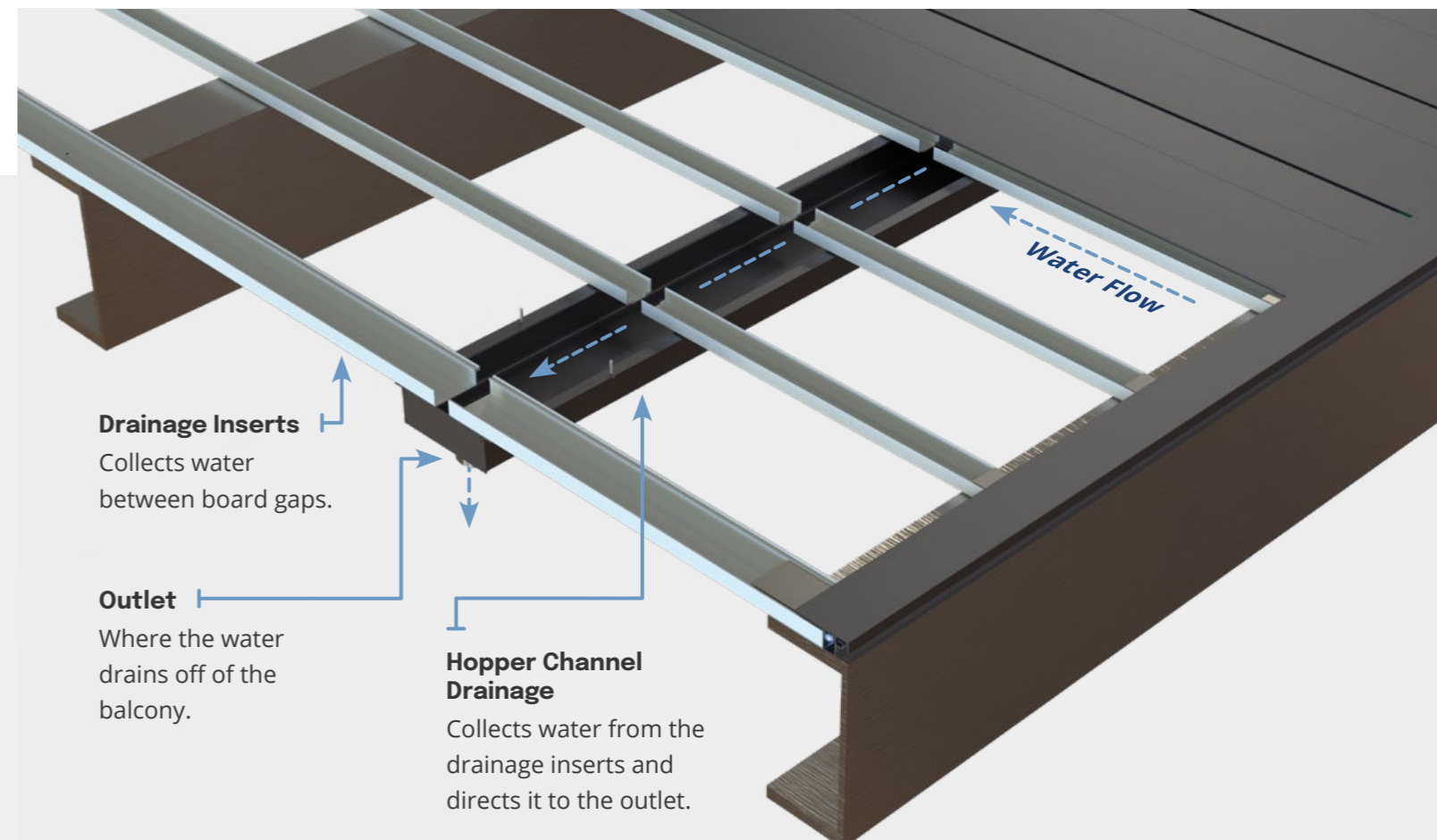

Drainage Inserts

Collects water between board gaps.

Outlet

Where the water drains off of the balcony.

Hopper Channel Drainage

Collects water from the drainage inserts and directs it to the outlet.

Soffit System

Aluminium Soffit Board Assembly

How it works

- The Clip Rail is screwed to the joists.
- The End Piece can simply be clipped into the Clip Rail.
- The first soffit board is screwed to the joist, with each subsequent board being able to clip into the previous board.

Why use EnviroBuild soffits?

- A soffit layer neatly hides any substructure and catches any excess water.
- The soffit layer works with every solution EnviroBuild offers.
- Provides protection against the elements, such as rain, snow, and harsh sunlight, helping to prevent damage to the balcony structure over time

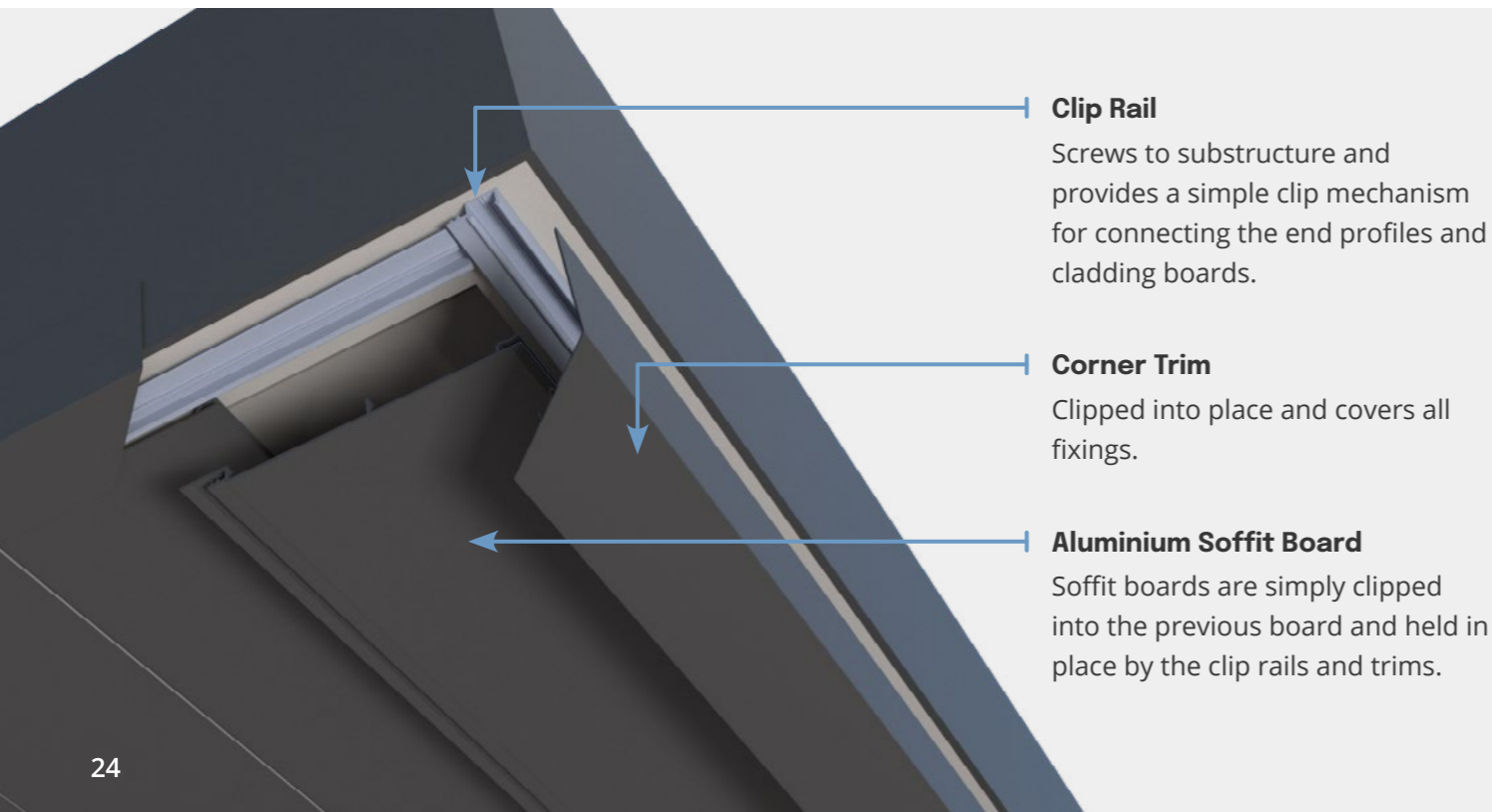
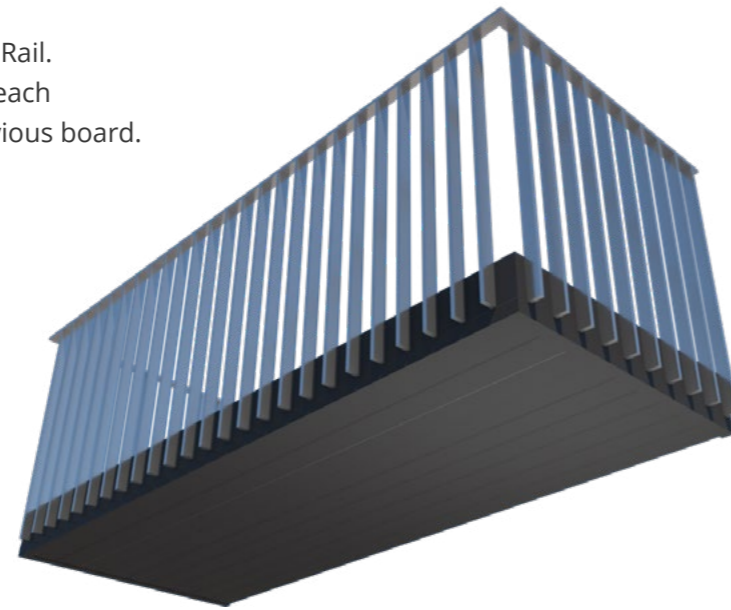

Clip Rail
Screws to substructure and provides a simple clip mechanism for connecting the end profiles and cladding boards.

Corner Trim
Clipped into place and covers all fixings.

Aluminium Soffit Board
Soffit boards are simply clipped into the previous board and held in place by the clip rails and trims.

Soffit Drainage

Soffit water-drainage

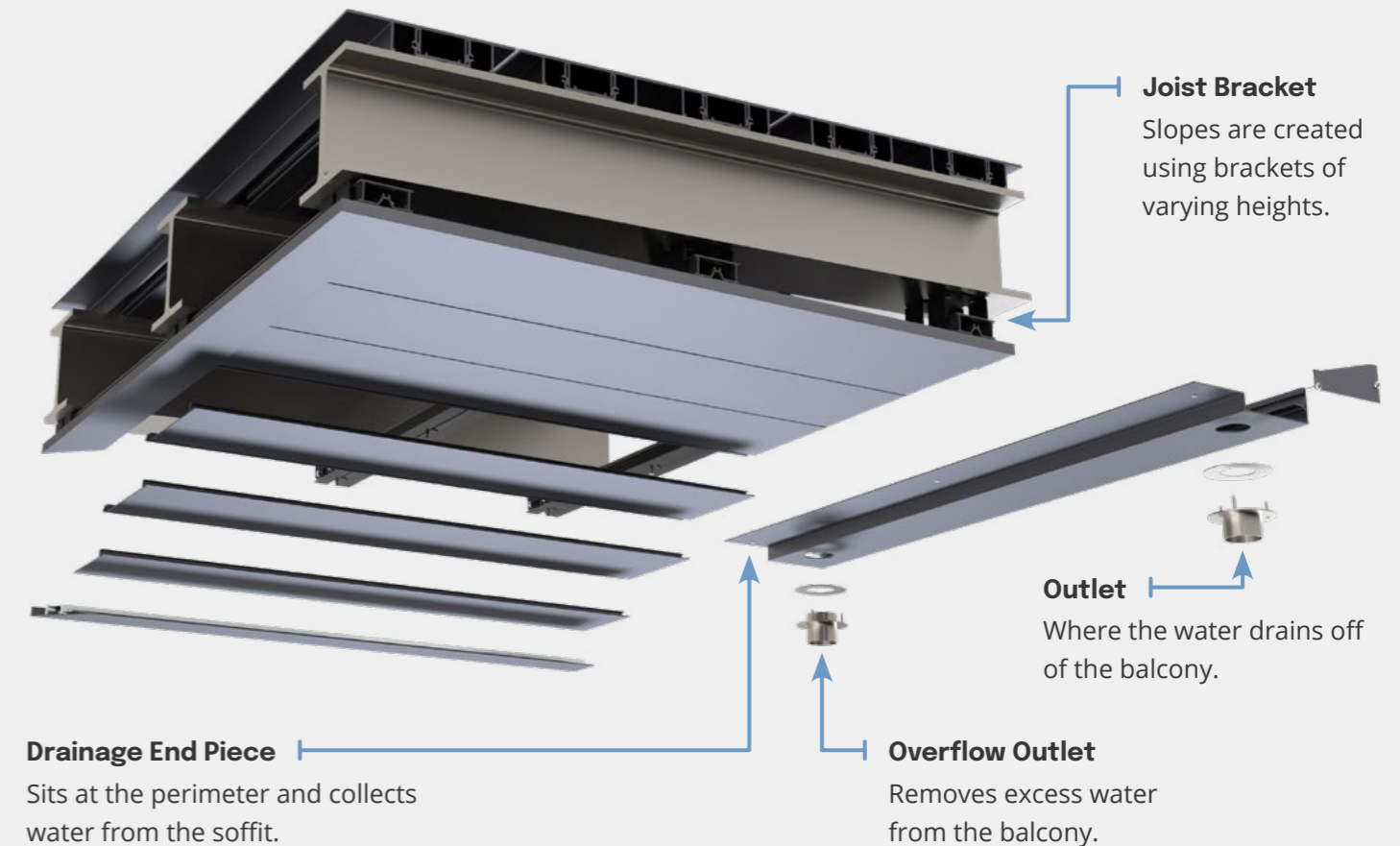

Joist Bracket
Slopes are created using brackets of varying heights.

Outlet
Where the water drains off of the balcony.

Drainage End Piece
Sits at the perimeter and collects water from the soffit.

Overflow Outlet
Removes excess water from the balcony.

Creating Slopes

Joist brackets of varying heights are screwed into the joists at different points for total vertical control. This way, any water can be directed along the soffit and into the outlet.

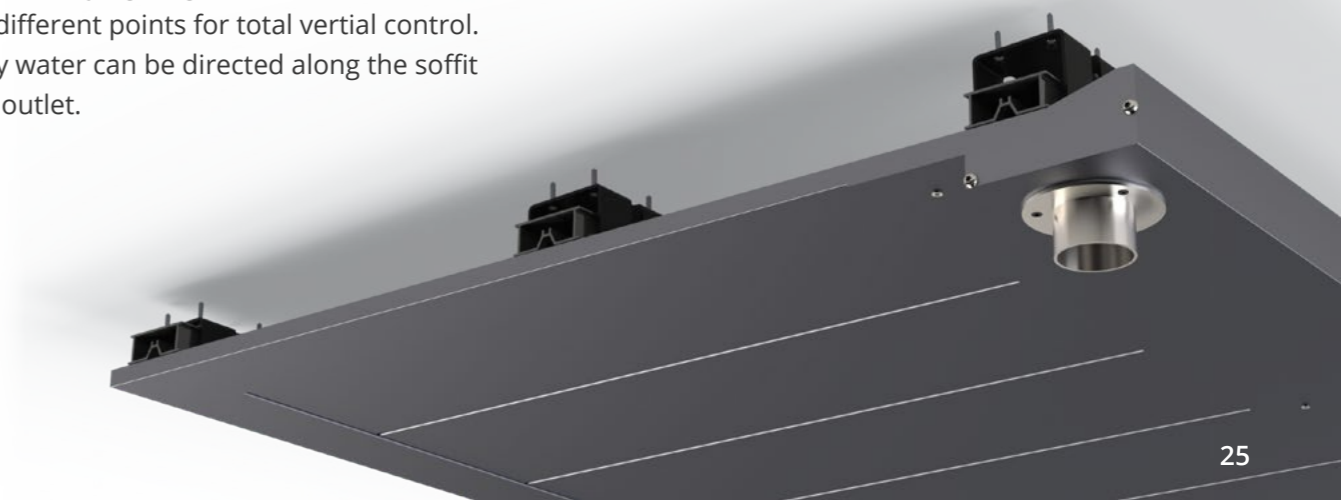

Edging Detail

Decking finish

Creates a seamless finish

- The Clip Rail is screwed to the substructure below (can be screwed into steel beams).
- The edge piece can then simply be clipped onto the clip rail.
- The edge piece neatly hides the cut board ends.

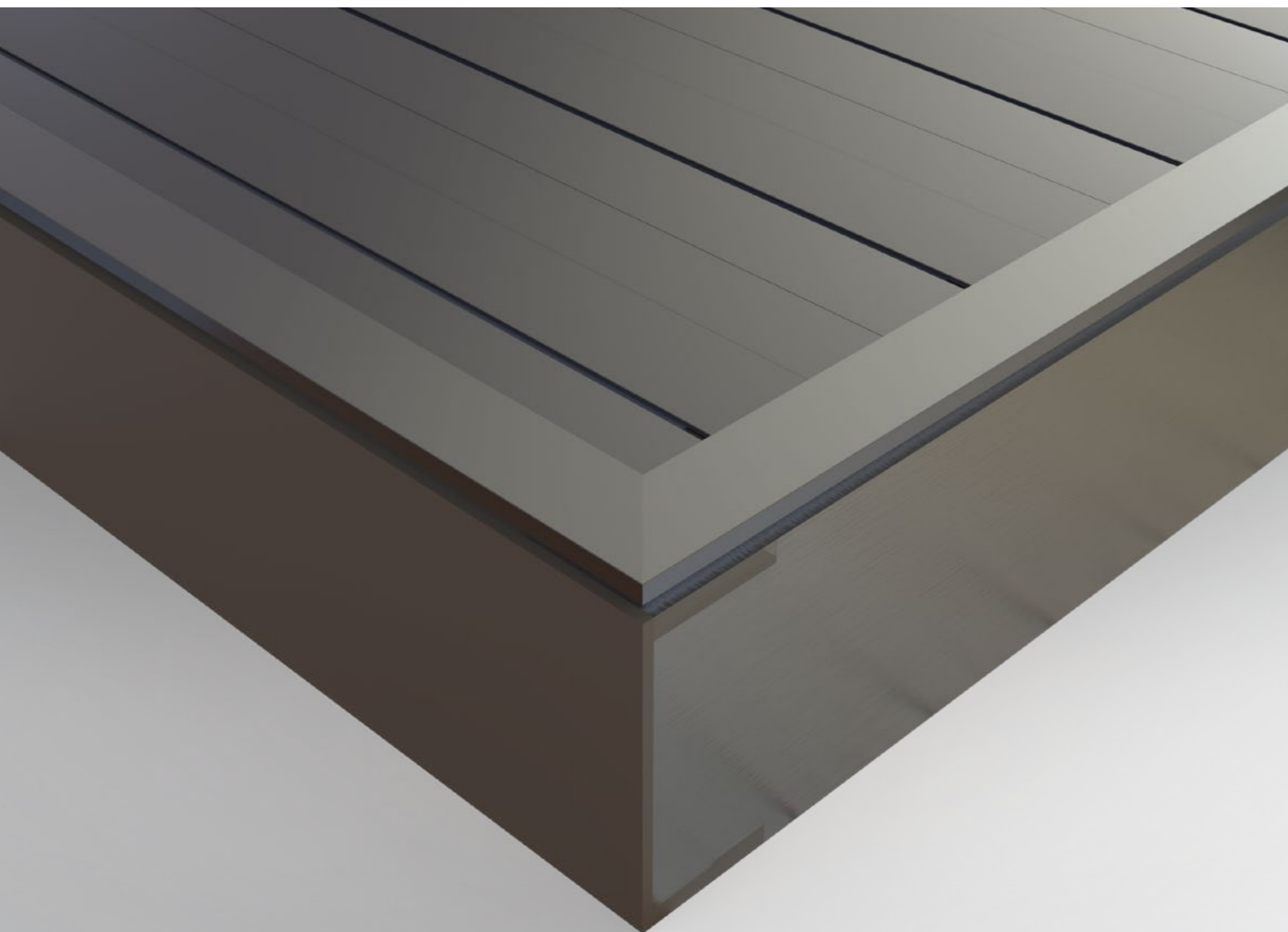
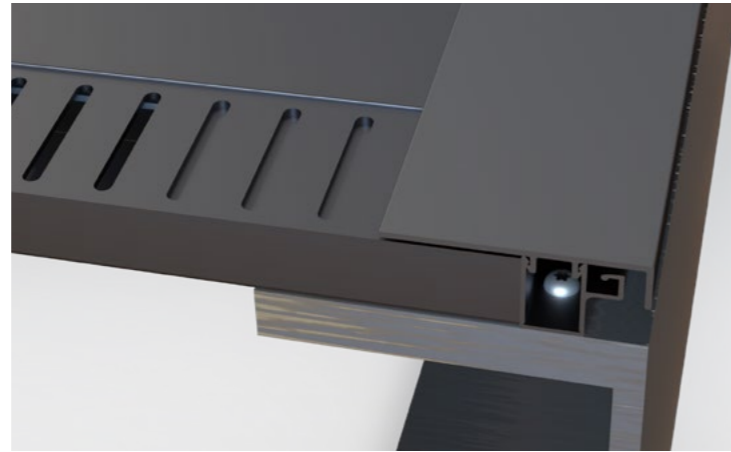

Non-combustible Support

Adjustable Steel Pedestals

With adjustable heights ranging from 5-500 mm by a simple rotation of the head, these supports make even the most challenging installations cost and time effective.

Slope Correcting System

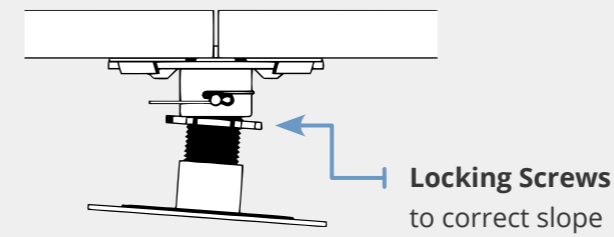



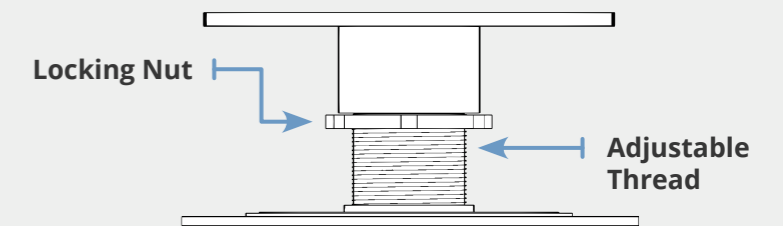

Rotate to Adjust Height



Shim System For Ultra-Low Heights



Pedestal Accessories

-  **Protective Membrane**
Protects roofing membrane.
-  **2.5 mm Paving Spacers**
For MESA joists.
-  **MESA 3.5 mm Paving Spacer Gasket**
2 or 4-way gaskets for quick paving spacing. Fins are removable. (Metal gaskets can also be used).
-  **MESA Paving Edge Bar**
Secure paving slabs to support pedestals.

Aluminium Powder Coating

Qualicoat on all aluminium products

Powder coating enhances the contemporary appearance of the aluminium board, as well as adding an important layer of protection to its outer surface. EnviroBuild's aluminium decking has been engineered in conjunction with the powder coating manufacturer to create a powder with a much

higher slip resistance, meaning the boards have exceptional wet slip resistance compared to off-the-shelf architectural powder coatings.

EnviroBuild's aluminium decking is Qualicoat certified. Qualicoat is the industry leading quality label scheme valid worldwide, whereby the manufacturing process has to meet particular standards which are inspected and tested by laboratories accredited to ISO 17025.



✓ Coated to Qualicoat Standard

At 60-80 microns, the coating on these boards meet the Qualicoat Accreditation standard.



The Qualicoat 'Seaside' Class is also available with added corrosion protection. A deeper acid or alkaline etching removes more trace elements when pre-treating, making the grain boundaries of the boards more resistant.

🕒 High Quality

Manufactured by AkzoNobel, the coating on these aluminium boards is reliable, durable and of the highest possible quality. AkzoNobel was the first to offer an environmental product declaration and meets stringent Qualicoat Class 1 requirements.

🕒 Long Lasting

The Qualicoat Class 1 standard ensures a high level of durability required for long term outdoor use products. In the event that damage occurs, matching touch up pens are available in every colour.

Steel Pedestals Specification

Flat Steel Pedestals

Product	Base LxW (mm)	Head Diameter (mm)	SKU
25-35 mm	100x100	90	PA-SP-M-25
30-40 mm	100x100	90	PA-SP-M-30
40-50 mm	100x100	90	PA-SP-M-40
50-70 mm	100x100	90	PA-SP-M-50
60-90 mm	100x100	90	PA-SP-M-100
90-150 mm	100x100	90	PA-SP-M-90
150-280 mm	100x100	90	PA-SP-M-150
280-500 mm	100x100	90	PA-SP-M-280



Slope Correcting Flat Steel Pedestals

Product	Base LxW (mm)	Head Diameter (mm)	SKU
45-55 mm	100x100	90	PA-SP-M-45
55-70 mm	100x100	90	PA-SP-M-55
70-110 mm	100x100	90	PA-SP-M-70
100-160 mm	100x100	90	PA-SP-M-100
150-260 mm	100x100	90	PA-SP-M-150
250-480 mm	100x100	90	PA-SP-M-250



Joist Pedestals

Product	Base LxW (mm)	Head Diameter (mm)	SKU
10-25 mm*	100x100	100	DA-SP-M-10
25-35 mm	100x100	100	DA-SP-M-25
30-40 mm	100x100	100	DA-SP-M-30
40-50 mm	100x100	100	DA-SP-M-40
50-70 mm	100x100	100	DA-SP-M-50
60-90 mm	100x100	100	DA-SP-M-60
90-150 mm	100x100	100	DA-SP-M-90
150-280 mm	100x100	100	DA-SP-M-150
280-500 mm	100x100	100	DA-SP-M-280



* Installation includes creating a 20 mm hole through the middle of the joist

Aluminium Joists Specification



Specification Table

Profile	20x50, 40x50, 80x50 mm
Length	3600 mm (or bespoke)
Material	T6-6063 Aluminium
Finish	Black powder coat
Reaction to Fire	EN 13501-1: Class A2 (or A1 mill finish)
Linear Mass	20x50: 0.585 kg/m 40x50: 0.747 kg/m 80x50: 1.070 kg/m

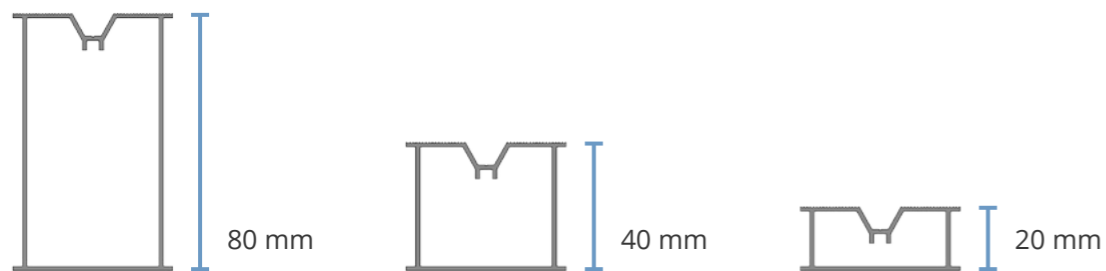

Span Tables (Max. Pedestal Spacing)

20x50 mm

	Deflection (m)		
	1/200	1/360	1/480
2.5 kN/m ²	0.70	0.55	0.50
4 kN/m ²	0.60	0.45	0.45
5 kN/m ²	0.55	0.45	0.40

40x50 mm

	Deflection (m)		
	1/200	1/360	1/480
2.5 kN/m ²	1.20	1.00	0.90
4 kN/m ²	1.05	0.85	0.75
5 kN/m ²	0.95	0.80	0.70

80x50 mm

	Deflection (m)		
	1/200	1/360	1/480
2.5 kN/m ²	2.15	1.75	1.60
4 kN/m ²	1.80	1.50	1.35
5 kN/m ²	1.70	1.40	1.25

A safety factor of 1.5 is included in spacings.
Calculations based on three points of loading.

+44 (0) 203 959 1220

Aluminium Cladding Spec.



Specification Table

Profile	10 x 172 mm
Length	3600 mm (or bespoke)
Material	T6-6063 Aluminium
Finish	Qualicoat 1 textured powder coat
Reaction to Fire	EN 13501-1: Class A2
Linear Mass	0.798 kg/m
Tolerance	TS EN 755-9
Fixtures	Clip rails

Span Table

3 Point Max Span 600 mm

2 Point Max Span 600 mm

Max Cantilever 100 mm





2 kN point load, 7 kN/m², 5 mm deflection



Cladding boards clipped together

Fixings & Finishings

Item

Clip Rail		Clip mechanism for securing boards to
End Profile		Covers fixings at the top and bottom
Butt Joint Cover		Covers fixings at butt joints
Inside Corner Cover		Covers fixings at corners
Outside Corner Cover		Covers fixings at corners

 Anthracite Grey 7016  Grey Brown 8019

Bespoke lengths and colours available upon request



Full Install

Pro-Grip Specification

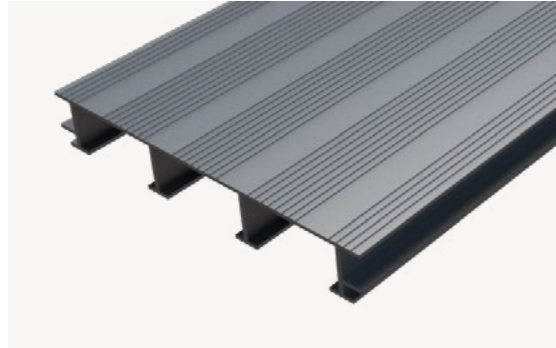

Specification Table

Profile	145 x 21 mm
Length	3600 mm
Weight	8.55 kg/m ²
Material	T6 6063 Aluminium
Finish	Qualicoat 1 textured powder coat
Reaction to Fire	A2 s1 d0 and A2 _{fl} - s1
Warranty	Up to 30 years
Fixtures	Clip system
Pendulum Test Slip Resistance (PTV)	BS EN 14231, Dry: 68, Wet: 46 (Low slip potential)
Micro Roughness Slip Resistance	Rz: 25 µm (Low slip potential)



Span Table





3 Point Max Span	650 mm
2 Point Max Span	500 mm
Max Cantilever	125 mm

2 KN point load, 7 kN/m², 5 mm deflection

Fixings & Finishings

Item

Edge Support		Covers and supports ripped edges of deck boards
Starter Clips		Simple installation for the first deck board
Hidden Fasteners		Creates uniform 6 mm gaps

-  Sepia Brown 8014
-  Grey Brown 8019
-  Dusty Grey 7037
-  Anthracite Grey 7016

Bespoke lengths and colours available upon request



Aqua-Channel Specification



Specification Table

Profile	150 x 21 mm
Length	3600 mm
Weight	9.57 kg/m ² (using gap insert)
Material	T6 6063 Aluminium
Finish	Qualicoat 1 textured powder coat
Reaction to Fire	A2 s1 d0 and A2 _{fl} - s1
Warranty	Up to 30 years
Fixtures	MESA® Self-drilling Countersunk Screws
Pendulum Test Slip Resistance (PTV)	BS EN 14231, Dry: 68, Wet: 41 (Low slip potential)
Micro Roughness Slip Resistance	Rz: 21 µm (Low slip potential)





Span Table

3 Point Max Span	650 mm
2 Point Max Span	575 mm
Max Cantilever	150 mm

2 KN point load, 7 kN/m², 5 mm deflection

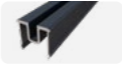
Fixings & Finishings

Item

Start/End Trim		Screwed along channel to substructure and starts/ends the deck
Gap Insert		Snaps into place, gives appearance of 150 mm wide decking
Flush Insert		Snaps into place, gives appearance of continuous deck
Threshold Drainage		Collects water at the threshold
Perimeter Drainage		Collects water at the perimeters

-  Anthracite Grey 7016
-  Grey Brown 8019

Bespoke lengths and colours available upon request



Strong-Span Specification

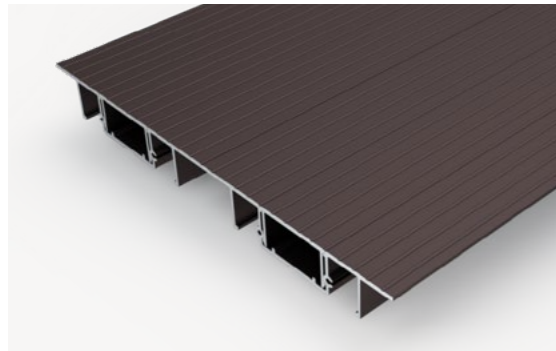

Specification Table

Profile	300 x 30 mm
Length	Bespoke, up to 6500 mm
Weight	15.36 kg/m ² (including insert)
Linear Mass	4.608 kg/m (including insert)
Material	T6 6063 Aluminium
Finish	Qualicoat 1 textured powder coat
Reaction to Fire	A2 s1 d0 and A2 _{fl} - s1
Warranty	Up to 30 years
Fixtures	MESA® Self-drilling Countersunk Screws
Pendulum Test Slip Resistance (PTV)	BS EN 14231, Dry: 68, Wet: 41 (Low slip potential)
Micro Roughness Slip Resistance	Rz: 21 µm (Low slip potential)

Span Table

3 Point Max Span	1200 mm
2 Point Max Span	1050 mm
Max Cantilever	400 mm

2 KN point load, 7 kN/m², 5 mm deflection

Fixings & Finishings

Item

Insert  Snaps into place to cover fixings in board channels

Drainage Channel  The insert is flipped to create drainage channels

 Anthracite Grey 7016

Bespoke lengths and colours available upon request



Full Install

Low-Fix Specification



Specification Table

Profile	200 x 21 mm
Length	3900 mm (or bespoke, up to 6000 mm)
Weight	9.57 kg/m ² (including insert)
Material	T6 6063 Aluminium
Finish	Qualicoat 1 textured powder coat
Reaction to Fire	A2 s1 d0 and A2 _{fl} - s1
Warranty	Up to 30 years
Fixtures	MESA® Self-drilling Countersunk Screws

Span Table

3 Point Max Span	800 mm
2 Point Max Span	700 mm
Max Cantilever	200 mm

2 KN point load, 7 kN/m², 5 mm deflection

Fixings & Finishings

Item

Insert  Snaps into place to cover fixings in board channels

 Anthracite Grey 7016

 Grey Brown 8019

Bespoke lengths and colours available upon request



Full Install

Porcelain Specification (Stone Effect)









Specification Table

Dimensions	600 x 600 mm
Height	20 mm
Weight	44.72 kg/m ² , 16.1 kg (per tile)
Reaction to Fire	EN 13501-1: Class A1
Classification	BI _a Porcelain tiles
Water Absorption	E _b 0.1-0.2% (Oyster), E _b <0.5% (Shore), E _b ≤ 0.15% (All Else)
Flexural Tensile Strength	43 N/mm ² (Oyster), >35 N/mm ² (Shore), 50 N/mm ² (All Else)
Breaking Strength	8500 N (Oyster), >1300 N (Shore), 9000 N (All Else)
Pendulum Test Slip Resistance (PTV)	BS EN 14231, 70

Fixings & Finishings

Item

MESA® Adjustable Pedestals		Twist to adjust levels on uneven or sloping surfaces
Edge Bar		Attaches to spacer gasket and keeps a uniform perimeter
MESA® Spacer Gasket		Sits on adjustable pedestals for uniform positioning
Protective Rubber Membrane		Supports pedestals and protects roofing membrane
MESA® Adhesive		Applied to porcelain to prevent wind-uplift
Steel Tray Roof Profiles		Safely supports paving slabs

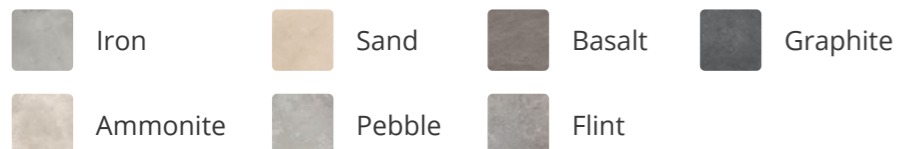

More colours and sizes are available upon request



Porcelain Specification (Wood Effect)





Specification Table

Dimensions	1200 x 300 mm
Height	20 mm
Weight	21.7 kg (per tile)
Reaction to Fire	EN 13501-1: Class A1
Classification	BI _a Porcelain tiles
Water Absorption	E _b ≤ 0.03%
Modulus of Rupture	≥ 35 N/mm ²
Breaking Strength	>1300 N
Pendulum Test Slip Resistance (PTV)	BS EN 14231, Dry: 78, Wet: 71
Micro Roughness Slip Resistance	Rz: 21 µm

Fixings & Finishings

Item

MESA® Adjustable Pedestals		Twist to adjust levels on uneven or sloping surfaces
Edge Bar		Attaches to spacer gasket and keeps a uniform perimeter
MESA® Spacer Gasket		Sits on adjustable pedestals for uniform positioning
Protective Rubber Membrane		Supports pedestals and protects roofing membrane
MESA® Adhesive		Applied to porcelain to prevent wind-uplift
Steel Tray Roof Profiles		Safely supports paving slabs



Fibre Cement Specification



Specification Table

Profile	200 x 25 mm
Length	2440 mm
Weight	40 kg/m ² , 19.5 kg (per board)
Linear Mass	4.608 kg/m (including insert)
Material	Cement, quartz sand, pulp
Finish	3D wood texture
Reaction to Fire	EN 13501-1: Class A1
Fixtures	Sentinel 8 mm clips
Bending Strength	21.95 MPa
Pendulum Test Slip Resistance (PTV)	BS EN 14231, Dry: 63, Wet: 43 (Low slip potential)
Micro Roughness Slip Resistance	Rz: 26 µm (Low slip potential)



Span Table

3 Point Max Span	400 mm
2 Point Max Span	300 mm
Max Cantilever	100 mm

2 KN point load, 7 kN/m², 5 mm deflection

Fixings & Finishings

Item

MESA® Aluminium Joist		Low-profile non-combustible joists
MESA® 4-Way Joist Cradle		Twist to adjust height and support joists in four directions
Hidden Fasteners		Creates uniform 6 mm gaps



Composite Deck Specification



Specification Table

Profile	145 x 21 mm (Explorer), 143 x 22 mm (Frontier)
Length	4000 mm
Weight	17.4 kg/m ² (Explorer), 24.3 kg/m ² (Frontier)
Linear Mass	2.603 kg/m (Explorer), 3.64 kg/m (Frontier)
Material	Wood-polymer composite
Reaction to Fire	Cfl-s1
Fixtures	Clip system
Bending Strength	27.4 MPa (Explorer), 34.5 MPa (Frontier)
Water Absorption	4.32% (Explorer), 0.63% (Frontier)
Pendulum Test Slip Resistance (PTV)	BS EN 14231, Dry: 62, Wet: 49 (Explorer, Texture Side), Dry: 56, Wet: 38 (Explorer, Groove Side), Dry: 46, Wet: 38 (Frontier)
Micro Roughness Slip Resistance	Rz: 27 µm (Explorer, Texture Side), Rz: 24 µm (Explorer, Groove Side), Rz: 18 µm (Frontier)





Span Table

3 Point Max Span	300 mm (Explorer) 350 mm (Frontier)
2 Point Max Span	250 mm (Explorer) 300 mm (Frontier)
Max Cantilever	100 mm (Explorer) 100 mm (Frontier)

2 KN point load, 7 kN/m², 5 mm deflection

Fixings & Finishings

Item

MESA® Aluminium Joist		Low-profile non-combustible joists
MESA® Adjustable Pedestals		Twist to adjust levels on uneven or sloping surfaces
Starter Clips		Simple installation for the first deck board
Hidden Fasteners		Creates uniform 6 mm gaps

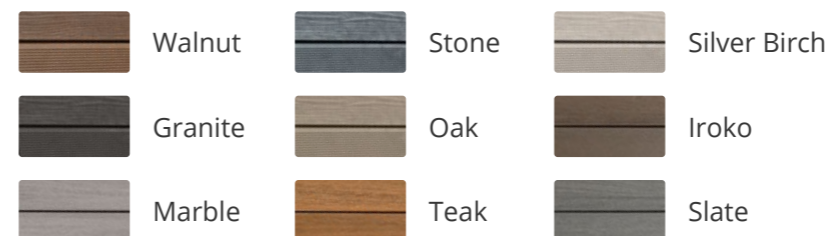

The Green Option

Aluminium CO₂ Reduction

We can lower our embodied carbon by manufacturing the most carbon intensive part of the process through renewable electricity.

Green your aluminium decking* for £1 per m²

& your substructure for 50p per m²

*Pro-Grip & Aqua-Channel

70% reduction in CO₂e (equivalent carbon dioxide) by using green electricity.

Because the Bayer process for manufacture of aluminium oxide from Bauxite, and then the Hall-Heroult process of smelting aluminium is so energy intensive, simply using renewable energy reduces the overall Global Warming Potential by 70%.



We donate 10% of our profits to sustainable causes.

We support Rainforest Trust who work with local communities and governments to protect endangered rainforests and species.

Our Service

Don't hesitate to get in contact

If you need help at any point from concept to installation, from small residential to large commercial projects, our expert team offer a free design and build quotation service, and can advise the best use of our products.

Technical support offering includes



Drawings



Take-offs

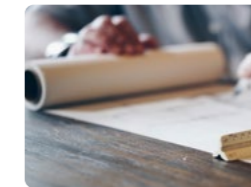

Bespoke Solutions

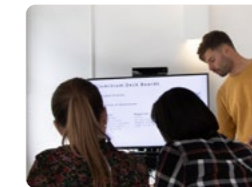

CPDs



Site Surveys

Support and resources

Backing up a wide product offering with comprehensive technical support and commercial resources. EnviroBuild can help with anything from bespoke solutions to install guides and technical sheets.



Free same-day quotation service



Bespoke delivery services including next day



EPDs for our aluminium and composites



Full technical sheets available



Expert team on hand



Our Clients



Get in touch

0203 959 1220

✉ info@envirobuild.com
www.envirobuild.com/commercial



The contents of this literature are provided by EnviroBuild Materials Limited in good faith and considered to be factual and accurate at the date of publication. These do not constitute specific technical recommendations and are provided for general information purposes only. It is for the engineer, architect or other relevant professional engaged to advise on any project to assess and satisfy themselves on the suitability of EnviroBuild Products for their intended use on that project. Please note that information contained in this literature may be subject to change with advances in usability and experience.

