

HYPERION[®] ALUMINIUM



Low-Fix Aluminum Decking

Need Help?

EnviroBuild has a large variety of resources and expert help at hand, ready to answer any questions you may have.

Resource Centre

In our online Resource Centre you can find How-to Videos, Technical Downloads, Case Studies and more. Our Resource Centre is a handy place where you can find everything you'll need for your project. Construction methods may change, refer to the Resource Centre for the latest Installation Guide versions.

<https://www.envirobuild.com/pages/resource-centre>

Contact Us

Our expert team is more than happy to assist you in realising your project, from concept to completion. We can help you with any questions on installation and put you in touch with one of EnviroBuild's trusted installers. If we can help, please don't hesitate to get in touch.

We're available:
Monday to Friday, 8:30am to 5:00pm

Phone:
UK, +44 (0) 203 959 1220
IRE, +353 1 447 0406

Email:
UK, info@envirobuild.com
IRE, ie-info@envirobuild.com

Location:
29 Pear Tree St,
London,
EC1V 3AG

<https://www.envirobuild.com/pages/get-in-touch>

Please Note

It is the customer's responsibility to determine the suitability of Hyperion® Aluminium Decking for their particular private or commercial installation. It is solely the customer's responsibility to consult with their local building control to determine fire classification project requirements.



Cont.

This symbol indicates the section continues onto the following page.

Flat Roof Installation

Flat Roof Installation Overview	4
Flat Roof Subframe Installation	5

Open Steel Installation

Open Steel Installation Overview	6
--	---

Stepwise Installation: Sub-surface Hopper Drainage

Pre-installation	7
Parts and Equipment Check	8
Installing the Decking Surface.....	9
Finishing The Deck Surface.....	10
Installing The Hopper Drainage Channel.....	11

Stepwise Installation: Sloped 40x125mm Boarder Draining

Pre-installation	12
Parts and Equipment Check	13
Joist Bracket Fixing	14
Border Drainage Channel Assembly	15
Support Joist Installation	16
Threshold Drain Installation	17
Deck Board Installation	18

Stepwise Installation: Sloped 40x50mm Boarder Draining

Pre-installation	20
Parts and Equipment Check	21
Joist Bracket Fixing	22
Border Drainage Channel Assembly	23
Border Drainage Channel Installation	25
Support Joist Installation	26
Threshold Drain Installation	27
Deck Board Installation	28

Supporting Information

Frequently Asked Questions	29
----------------------------------	----



Flat Roof Installation Overview

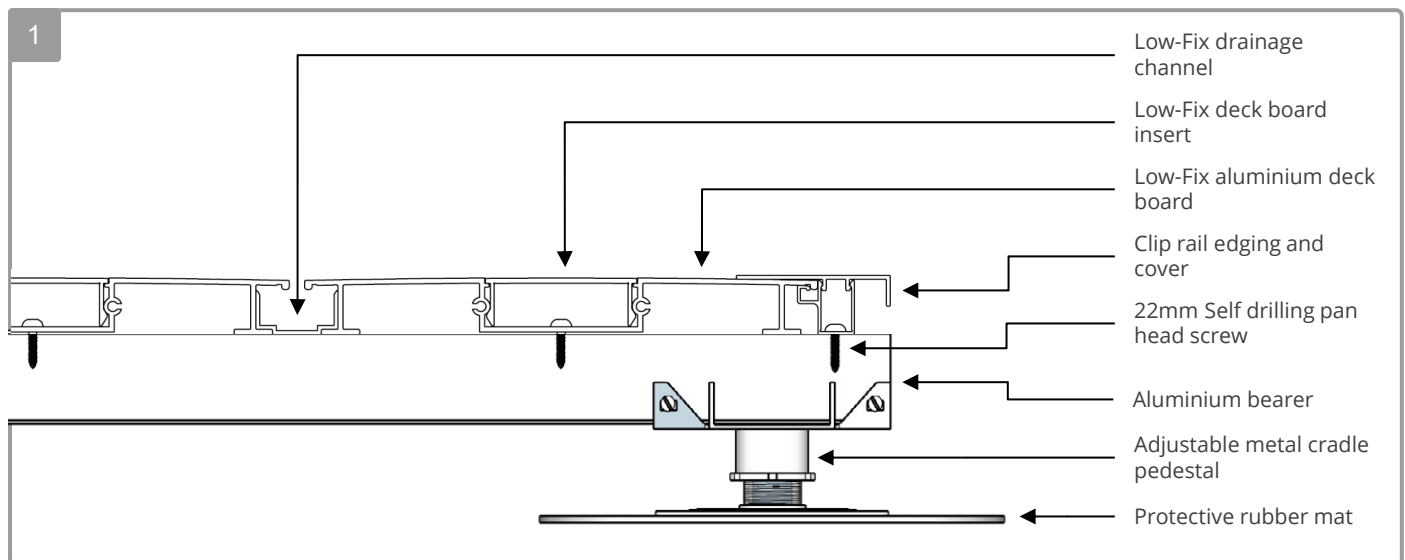

Installation Overview

With solid flat foundations and flat roof areas, a simple system using MESA adjustable steel cradles can be used (*fig. 1*). These pedestal support centres can be placed straight onto the ground with a protective rubber membrane and their heights adjusted by rotating the pedestal top.

- **Aluminium Deck Board**
Beautifully engineered fire-resistant deck boards. They are very simply fixed in place using pan head/hex head screws to joists along their channel. **Any cut edges or drilled holes with exposed metal should be coated to reduce the risk of long term powder coat peeling.**
- **Deck Board Insert**
Flush inserts provide a continuous decking appearance and hide screws from view and protect them from weathering.
- **Drainage Channel**
If surface draining layer is required to collect and direct water, the between-board drainage channels can be installed fitting tightly in-between boards without the need to fix down with screws.
- **Clip-In Edge Trim**
An edging clip rail is screwed to MESA® Aluminium Joists and a cover is simply clipped in place to cover board ends and sides, making this a simple screwless system to install.
- **MESA® Adjustable Steel Cradle**
Twist to adjust levels on uneven or sloping surfaces with minimal effort for fast and effective installation.
- **MESA® Aluminium Joist**
These low-profile joists can be very easily screwed into the cradle of the steel pedestal.
- **Protective Rubber Membrane**
A supportive base used in roofing solutions to prevent damage to roof membranes by steel pedestals.

Recommended Tools

- Power drill
- Cutting saw; with blade suitable for aluminium, preferably a mitre saw (*see 'Frequently Asked Questions', page 21*)
- Pan head screws
- Spirit level
- Safety boots (steel toe caps and pierce resistant soles)
- Safety gloves
- Eye protection
- Safety helmet
- Coating for exposed cut aluminium ends

! A 6 mm thermal expansion gap should be left between lengths of board and a 10-12 mm gap should be allowed around the perimeter to enable water to readily drain away.

Flat Roof Subframe Installation

Substructure Spacing

The height dimension of the aluminium joist will determine how often it must be supported. Ensure that the distances between support centres beneath your joists are no greater than below.

Aluminium Joist Profile	Maximum Support Span
20 x 50 mm	500 mm
40 x 50 mm	1000 mm
80 x 50 mm	1400 mm

- This span table is for 2.0 kN point loads or 5kN/sqm with aluminium joists placed with no more than 600 mm centres under boards
- For more detail on joist support spacing visit our website

Preparing the Area

- Ensure the roofing membrane is 100% water-tight and free from debris.
- Check that the installation area has a drainage slope that complies with building regulations.
- It is recommended to install a gutter or scupper to allow the draining of excess water.

Laying the Pedestals

1. Starting from the edge of the decking area, lay out your pedestals. The height of the steel pedestals can be adjusted by rotating the pedestal head and then locked into position using the locking nut (*fig. 2*). Refer to the Substructure Spacing section above for information on pedestal support spans.
2. Beneath each steel pedestal, lay a rubber membrane (or other sacrificial membrane) to protect the roof.

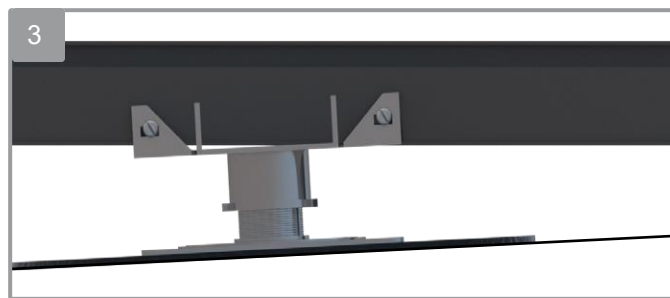
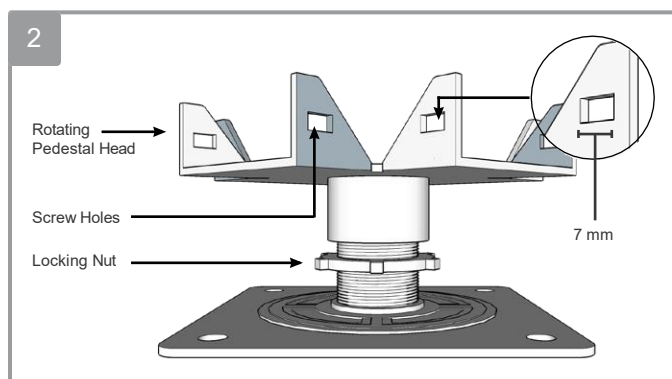

3. Check the slope of the pedestals are around 1:80 using a plum line or spirit level.
4. To adjust for differing gradients in the decking area, steel pedestals can be fixed to the joists at an angle (*fig. 3*). The pedestal should be attached in all 4 possible positions with a 20mm screw

Laying the Joists

5. Place your aluminium joists on top of your steel cradles. Aluminium joists can be laid end to end, supported by a pedestal. Make sure to leave a 6 mm expansion gap between the ends of the joists.
6. Alternatively, a full joist width can be used to support each deck board end at a butt joint. In this case you will need to double up on joists at butt joints. A 6mm spacing is recommended between joists at butt joints.
7. Using Tek screws, the joists can be fixed to the steel pedestals via the screw holes in the pedestal head (*fig. 2*).

Open Steel Installation Overview

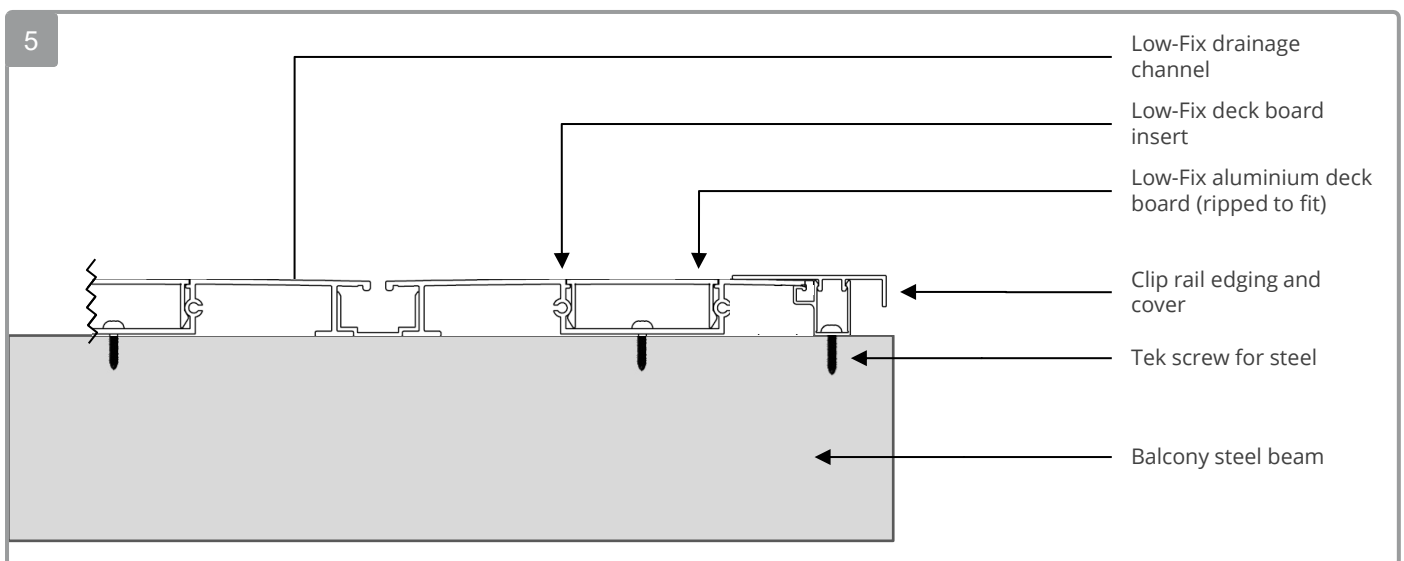
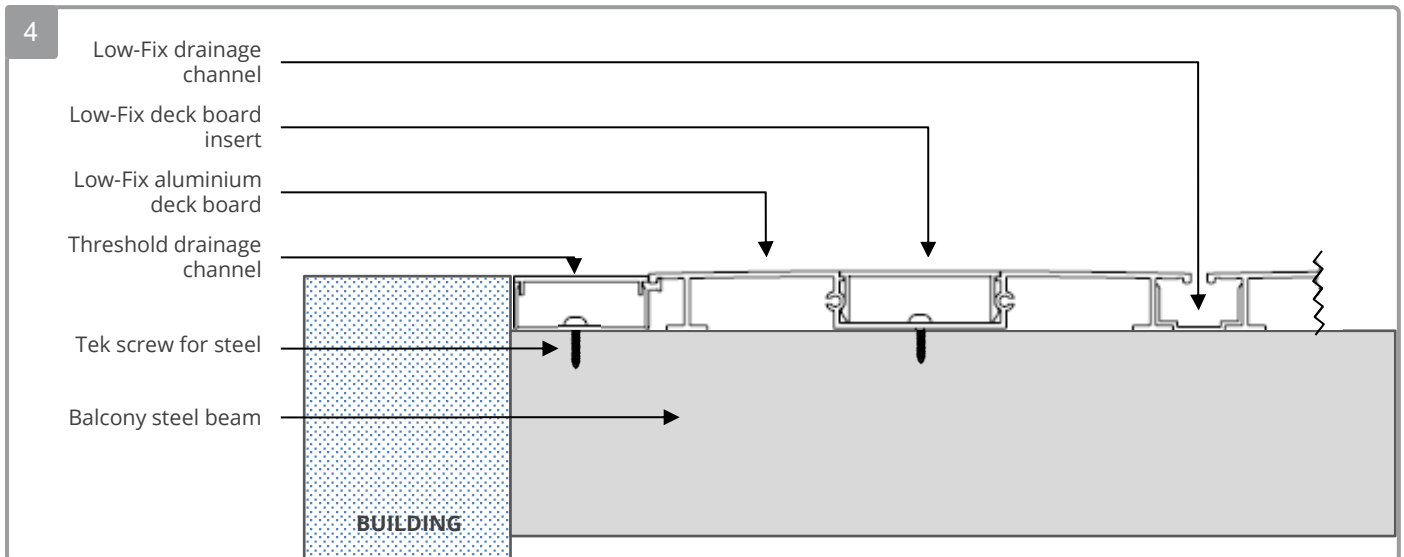

Installation Overview

Aluminium decking boards can be installed directly onto steel beams without the need for steel pedestals or aluminium joists (fig. 8). The same steps (see pages 6–7) can be followed for installing aluminium decking to steel beams, with the exceptions:

- The maximum tolerance for the steel beams is ± 2 mm. This is how high or low a beam can be from an adjacent beam.
- Always pre-drill steel beams when fixing down with appropriate Tek screws (not supplied by EnviroBuild).
- A slope creating system can be provided as detailed in this installation guide, which sits between the decking boards and the steel beams in order to provide a drainage slope.
- Each deck board end should be supported by at least 35 mm on the steel beam.
- At least a 50 mm width is required on the steel beam to support two board ends at butt joints.
- Low-Fix deck board fixing channel can accommodate up to 55mm craning eyelets if required, this allows all boards to be fully installed when craning balcony into position.
- **Any cut edges or drilled holes with exposed metal should be coated to reduce the risk of long term powder coat peeling.**

Installation Steps

1. Starting closest to the building, an optional threshold drainage channel can be fixed down with Tek screws to the balcony steels (fig.04), ensure the grooved lip is facing towards the decking area. With the base of the threshold drainage channel fixed in place, the cover plate can be clipped directly to this.
2. The first Low-Fix decking board can then be slotted to this and fixed down with Tek screws through the centre of the board – 1 screw must be used per supporting steel (fig.04).
3. With the deck board secured in place an optional between-board drainage channel can be slotted to its side and the next deck board fixed in place (this will leave a 6mm gap between boards), this does not need to be fixed down with Tek screws.
4. Continue the rest of the decking surface and rip the last deck board to fit leaving 30mm spacing from the decking edge for the edging cover, do not fix the ripped board down yet (fig.05).
5. Fix down with Tek screws the edging clip rail with its flat outer edge being 15mm from the decking surface edge, then secure the final ripped board so the ripped edge is resting on the clip rail support lip. Clip the edging cover over the top (fig.05).
6. Finally, push in all the deck board inserts, use a rubber mallet if required to help.

Stepwise Installation: Sub-surface Hopper Drainage

Pre-Installation

Low-Fix boards can create a water collecting surface, with interlocking drainage channels which are designed to mitigate the capillary effect.

To avoid water pooling the boards should be installed at a slope, forcing liquids down the continuous surface and into drainage channels either at the decking surface edges or underneath.

Where there is no slope the system remains an effective method of drainage, but water will remain on the boards for longer after rain

The Hopper Drainage Channel system provides a complete sub-surface drainage solution, primarily for use on projecting balconies. The hopper drainage channel sits between balcony steels and collects water from drainage channels sitting between the deck boards.

Water is prevented from flowing over the edges by clip on edging and a silicone based sealant.

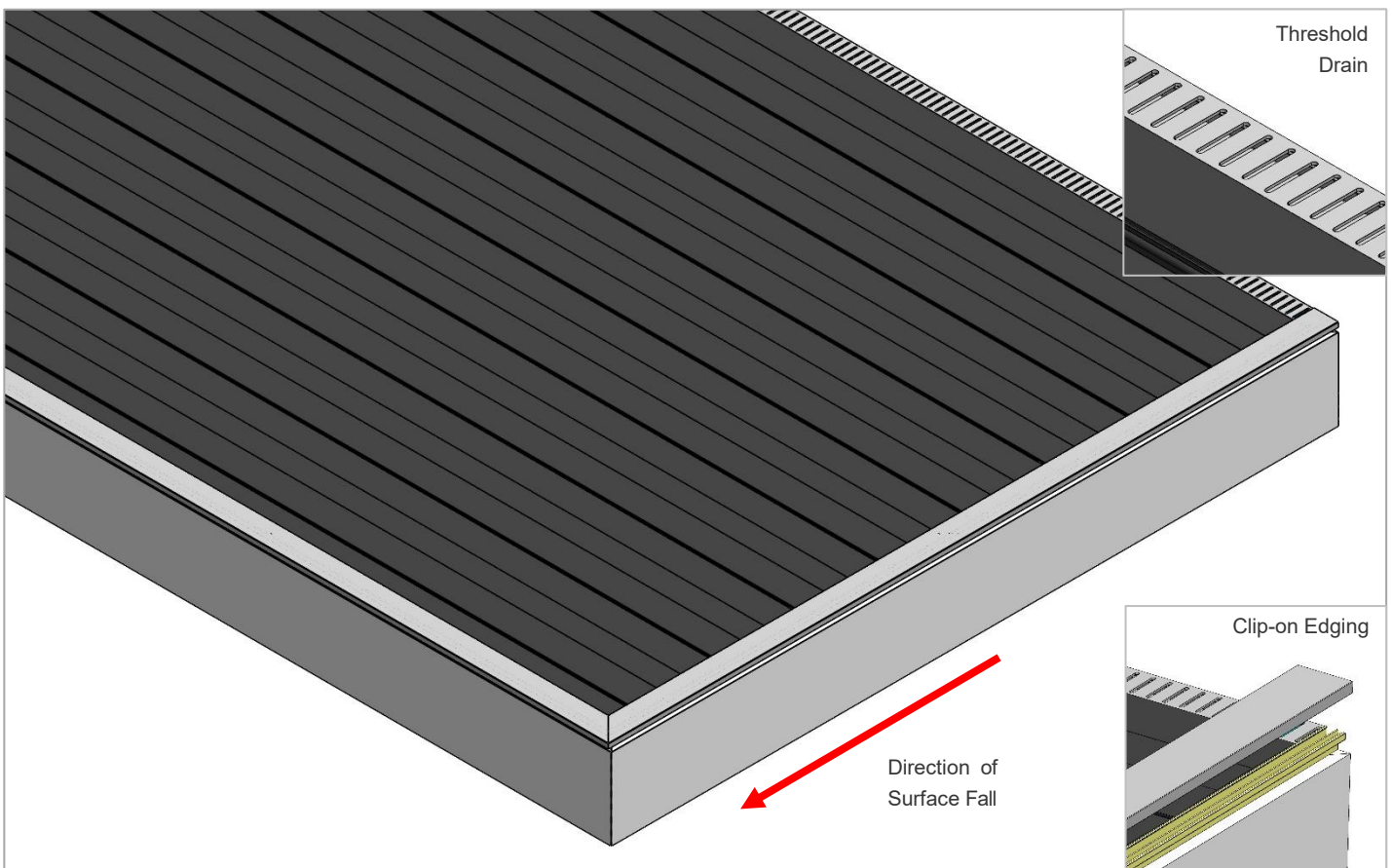

Before starting your installation, a few key considerations should be confirmed:



1. Direction of surface slope - We recommend a 1:80 fall away from the building on the decking layer, which can be designed into the balcony structure.
2. Direction of your boards - The system above shows how to install based on boards running widthways (parallel to the building).
3. Water collection point - Best practice will see water collected at the lowest point of the drainage channel system. This is likely to be the furthest point from the building. Pipes can be connected to outlets up to 70mm diameter.
4. Water overflow point - Opposite to the above an overflow spigot should be placed at the highest point in the drainage channel, to allow water a means of escape if the primary outlet becomes blocked.

Stepwise Installation: Widthways Aqua-Channel Board Installation

Parts and Equipment Check

It is essential to check you have all the parts required before installation, as per below:

Parts Required

Hopper drainage channel	
Hopper channel end plates	
Outlets	
Deck boards	
Deck board inserts	
Between board drainage channels	
Threshold drainage channel and cover	
Between board drainage channel seals	
Edging clip rail and cover	

Equipment Required

Appropriate PPE
Impact driver
Hand drill with 30mm metal drill bit
Chop saw with metal cutting blade
Metal snips
Coating for exposed cut aluminium ends

Installing The Decking Surface

If your balcony construction would not allow the sub-surface hopper to be positioned once the deck surface has been installed then start with Hopper Drainage Channel installation on page 11, otherwise proceed below and the hopper can be installed from the decking underside.

If you are using the optional threshold drainage channel, it should be installed prior to fitting any deck boards, otherwise proceed to step 5 below. This optional piece will only work if there is a route for water to flow directly under the threshold channel:

1. Cut the threshold drainage channel with cover to fit the balcony width; if you are using clip rail edging on balcony sides you will need to leave at least 30mm at either end. **Any cut edges or drilled holes with exposed metal should be coated to reduce the risk of long term powder coat peeling.**
2. Where the sub-surface Hopper drainage channel would sit to collect the deck surface water, drill a hole in the base of the threshold drainage channel, at least 30mm diameter.
3. Align the channel on the balcony steels such that it sits square to the balcony and fix down with Tek screws/bolts suitable for the steels. Use mineral washers to prevent any water egress (fig.01).
4. Insert at each end the drainage seal before clipping on the threshold cover, ensure the seal is pushed down fully in the corners (fig.02).
5. With optional threshold drainage channel fitted, start laying the deck boards: Cut the boards and between board drainage channels to fit the balcony width; if you are using clip rail edging on balcony sides leave at least 30mm at either end.
6. Remove the deck board insert from the board if it is in place and fit the ball edge of the deck board to the upward facing socket on the threshold drainage piece (fig.03). Where there is no threshold leave a 10-12mm gap or as prescribed in Building Regulations.
7. Fix the board down with Tek screws/bolts, pre-drill where required to the steels below through the exposed channel (fig.04). You can use mineral washers to prevent any water egress if desired.
8. Cut the between-board drainage channels so that they leave a 30mm gap (or drill a 20mm hole) over where the Hopper drainage channel would sit below the deck surface (fig.07). In one end of both cut lengths tightly press in the drainage channel seals ensuring the seal is firmly pressed into the corners (fig.05).
9. Slot the between-board drainage channel (inc. seals in place) next to the first fixed board (fig.06) and fix the next board tightly to it, this channel shouldn't need screwing in place, but a screw can be used if desired.
10. Keep fitting the boards and between board drainage channels until enough space remains for one board or less (fig.07).
11. If required, rip a deck board to fit the final space. Ensure to leave a 30mm gap between the board and the balcony edge for the clip rail edging (fig.11)****Special detail on next page.**

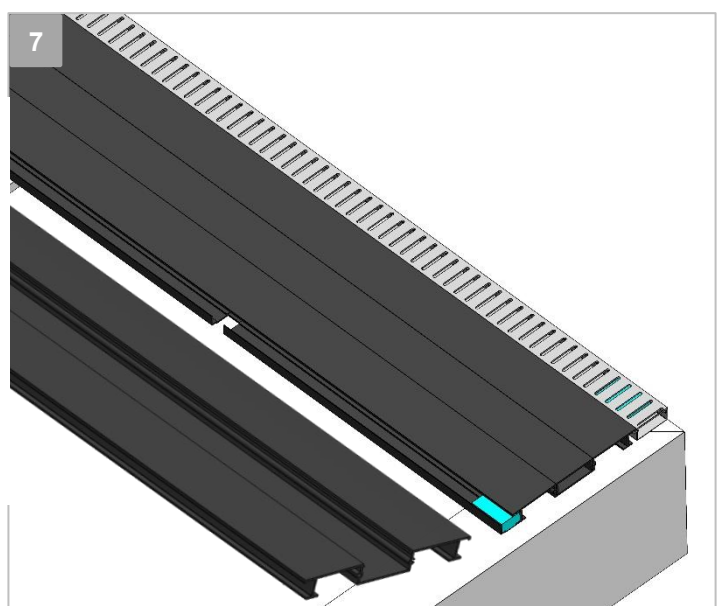
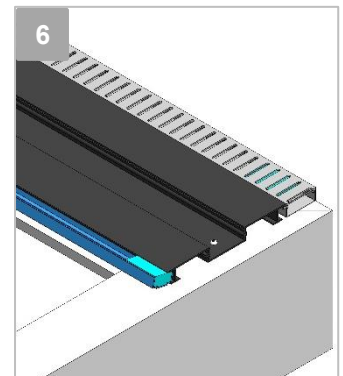
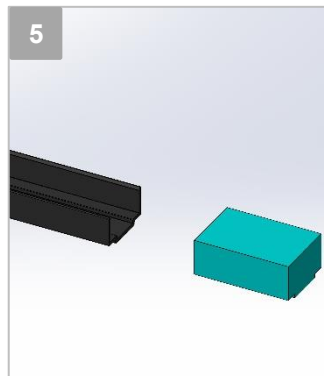
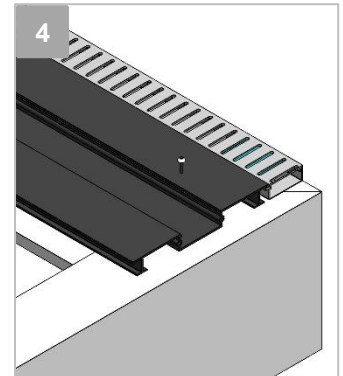
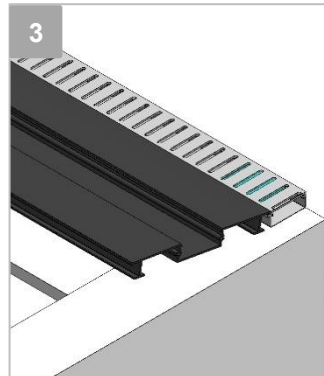
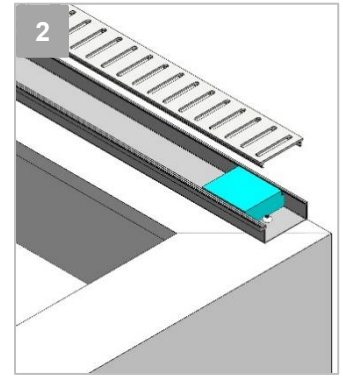
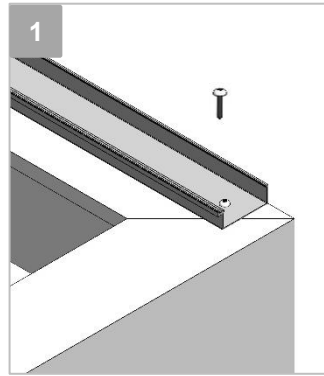

Finishing The Deck Surface

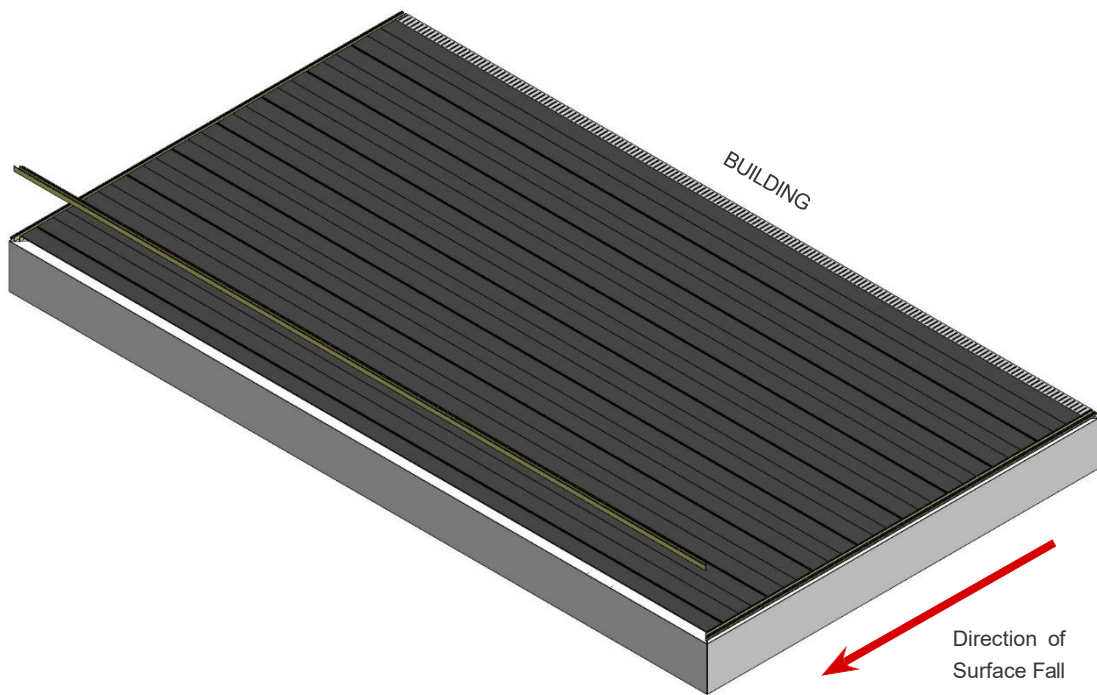

12. With all boards fitted, push in the deck board inserts. Either use a rubber mallet or firmly press into place (fig.08).
13. If you are using the optional clip-on edging to cover cut board edges, then cut the clip rail edging to length to fit the balcony edges (the covers can be mitred if desired).
14. Fix the mill finish clip rail down with suitable Tek screws/bolts, pre-drill where required to the steels below through the exposed channel (fig.09); where the clip rail sits perpendicular to the deck board length, face the protruding side tongue outwards from the balcony (fig.06), for clip rail parallel to the board length the tongue will face towards the boards as it supports their edge (fig.11).
15. With all clip rails fitted, clip in the edging covers. Either use a rubber mallet or firmly press into place (fig.10). To ensure water tightness around the edges put silicon sealant where the underside of the cover meets the boards before clipping the edging in place.

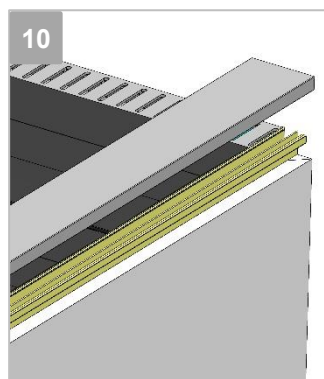
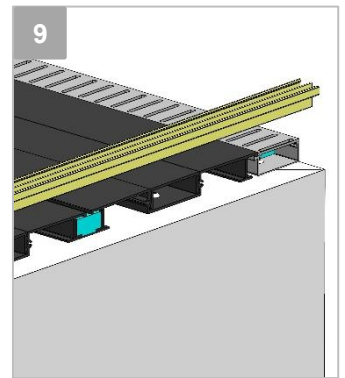
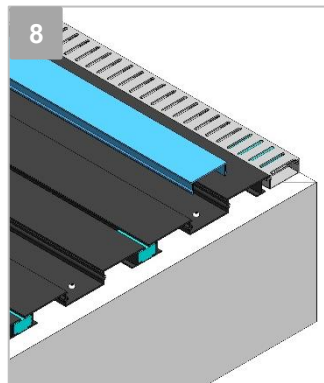

**Special Detail for Ripped Edge Support

Where the ripped board does not allow you to fix through the board fixing channel, the outer edge can be held up by the clip rail support (and clip-on cover holds the board in place), the last between-board drainage channel should be fixed down to the steels and screws should fix the deck board to the between-board channel (fig.11). A rubber washer should be used in these instances

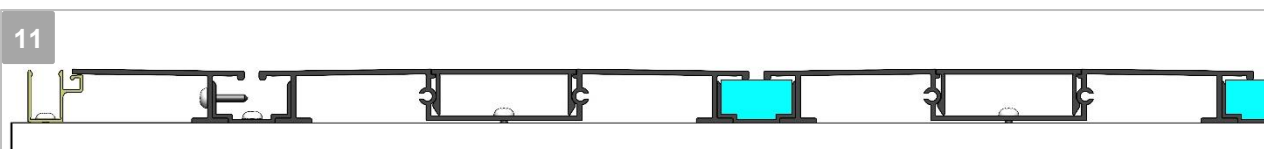

Installing The Hopper Drainage Channel

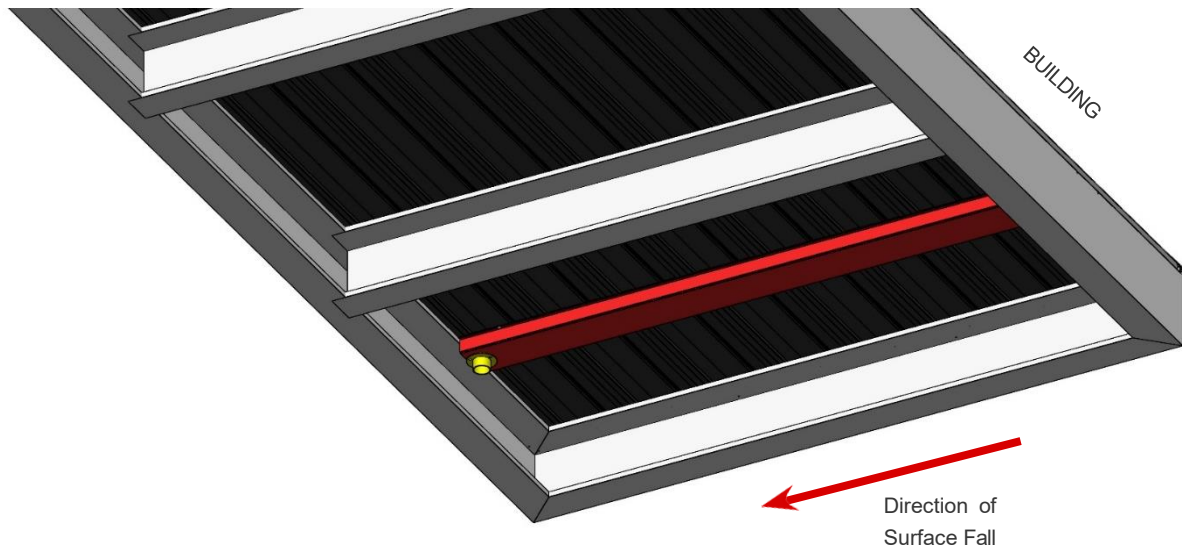

With the deck surface installed you can now fit the Hopper drainage channel to the underside of the deck (unless the balcony steel construction impedes ability to insert full hopper length from underside, these steps need to be carried out prior to fitting the deck board):

1. Cut the Hopper channel to length to fit the balcony, ensuring to leave min. 6mm at each end for the end plates with fixing screws.
2. Drill suitable sized holes in the drainage channel for the outlet and overflow outlet based on the desired drainage system (fig.12).
3. Fit the outlets to the Hopper channel, using silicon sealant if required (where rubber seals are not present).
4. Around the ends of the Hopper channel add silicon sealant (as highlighted in yellow) and screw the end plates to seal each end (fig.13).
5. With the Hopper complete, offer this up to the bottom of the decking surface where gaps have been left in the decking drainage channels (fig.14). For ease, pre-drill and use Tek screws along Hopper side flanges to fix in place (fig.15)- **screwing up into deck board fixing channel bases only.**
6. Finally, connect up the main outlet to the rainwater downpipes.
7. The overflow outlet should be placed 15mm above the usual outlet and be connected to a pipe flowing directly off and away from the building so that blockages are obvious

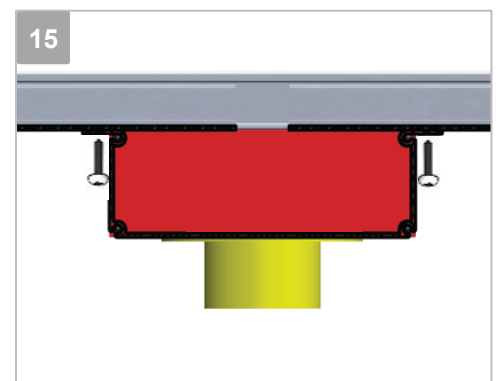
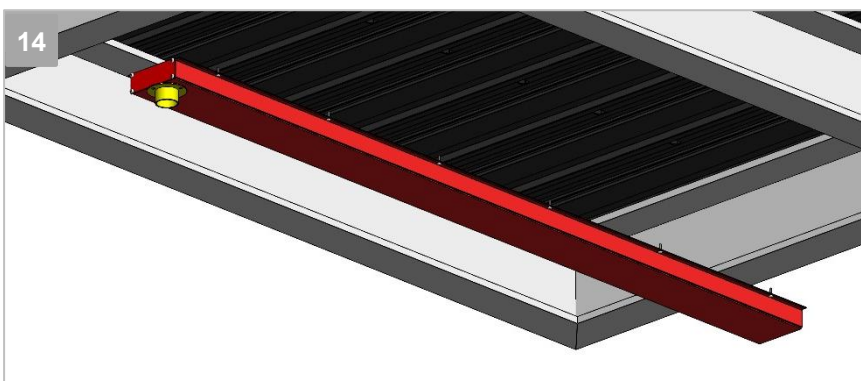
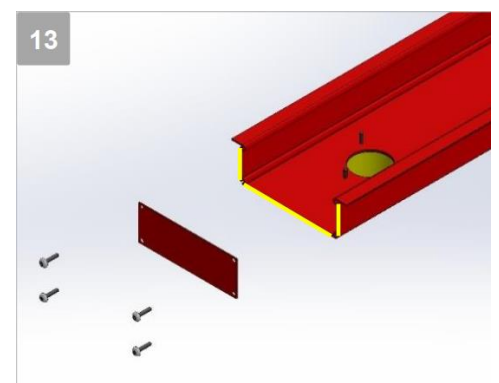
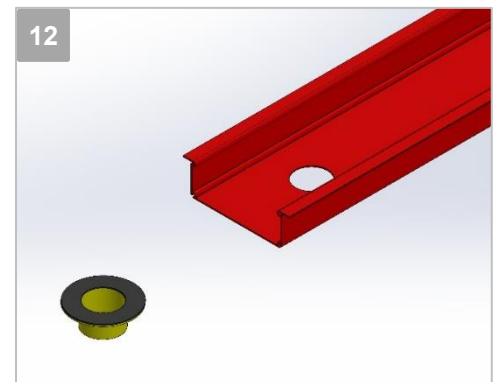

Stepwise Installation: Sloped 40x125mm Border Drainage

Pre-Installation

Low-Fix boards can create a continuous water collecting surface, with drainage channels designed to mitigate the capillary effect.

For perimeter/edge/boarder drainage, the boards should be installed at a slope, forcing liquids down the continuous surface and into drainage channels at the decking surface edge(s).

The 40x125mm Border Drainage Channel system provides a complete perimeter drainage solution, primarily for use on projecting balconies. Slots within the channel allow for easy fixing and assembly, reducing the need to screw down through the channel which can impact water-tightness.

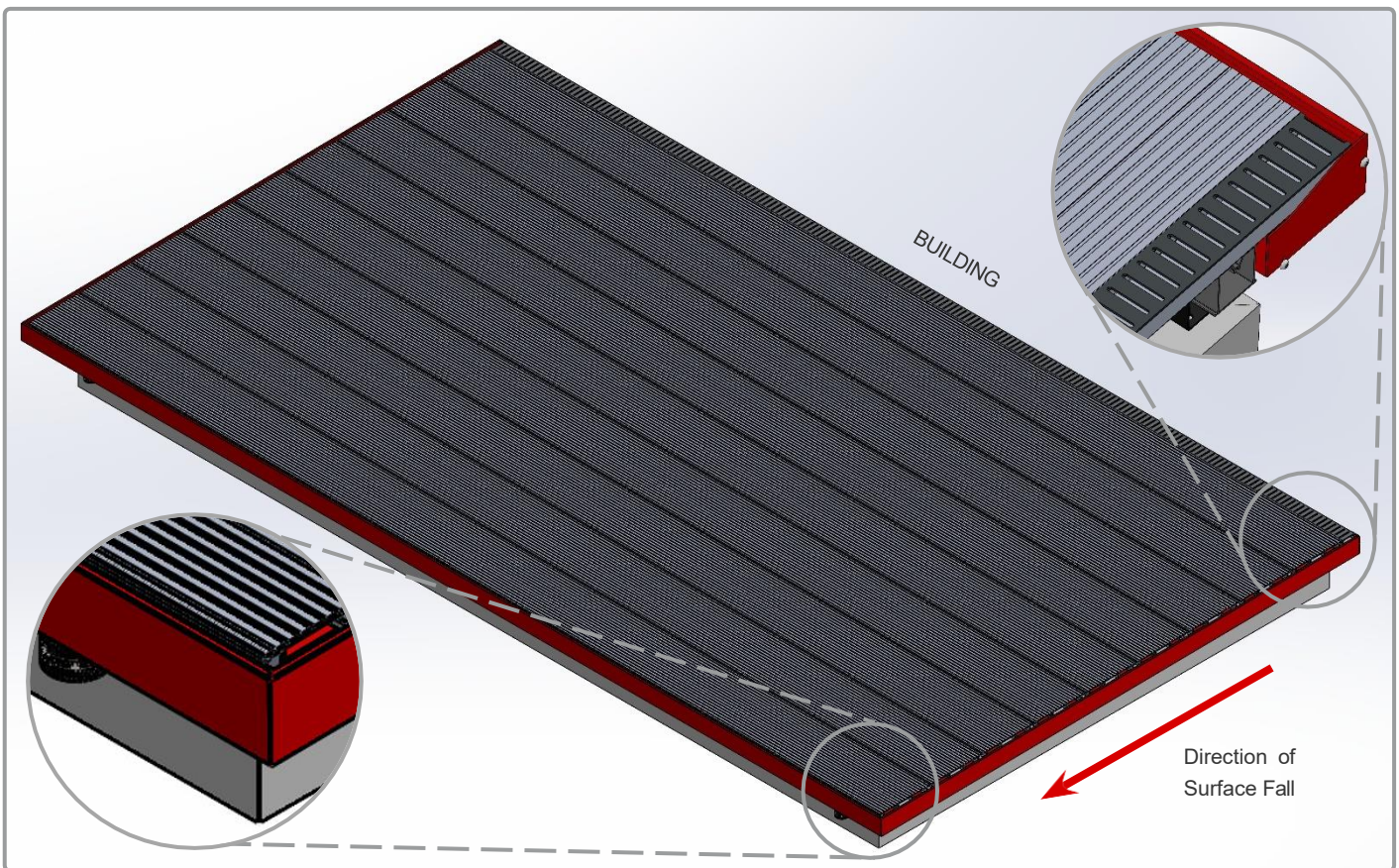

Pre-Installation Checks

Before starting your installation, a few key considerations should be confirmed:











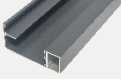



1. Direction of surface slope - We recommend a 1:80 fall away from the building on the decking layer.
2. Direction of your boards - The system above shows how to install based on boards running widthways (parallel to the building). If your balcony is >6.0m wide, we recommend running the boards depthways to avoid the need for butt-gaps, or alternatively longer boards (bespoke order, up to 6.5m) can be purchased on a longer lead time.
3. Water collection point - Best practice will see water collected at the lowest point of the border drainage channel system. This is likely to be the furthest point from the building. Pipes can be connected to 1 1/2" BSP outlet(s).
4. Water overflow point - an overflow outlet should be placed at the highest point in the lowest lying border drainage channel, to allow water a means of escape if the primary outlet becomes blocked.
5. End support joist positions – the support joists nearest to boarder drainage channels running perpendicular to the deck boards should be no more than 200mm from the outer edge of the decking area.

Stepwise Installation: Widthways Low-Fix Board Installation

Parts and Equipment Check

It is essential to check you have all the parts required before installation, as per below:

Parts Required

40x125mm Border drainage channel	
Channel end plates	
40x50mm Aluminium joists	
1.25" Outlet with additional nuts for overflow	
90 degree joining brackets	
Flat joining brackets (only when balcony width is >6.0m)	
Slope-creating joist brackets	
Bracket shims	
Self-drilling fixing screws	
Low-Fix Deck Boards	
Low-Fix Deck Board Inserts	
Between board drainage channels	
Threshold drainage channel and cover (optional)	
35x50mm L brackets	

Equipment Required

Appropriate PPE
Impact driver
Hand drill with 30mm metal drill bit
Chop saw with metal cutting blade
Metal snips
Allen key - 2.5mm

Joist Bracket Fixing

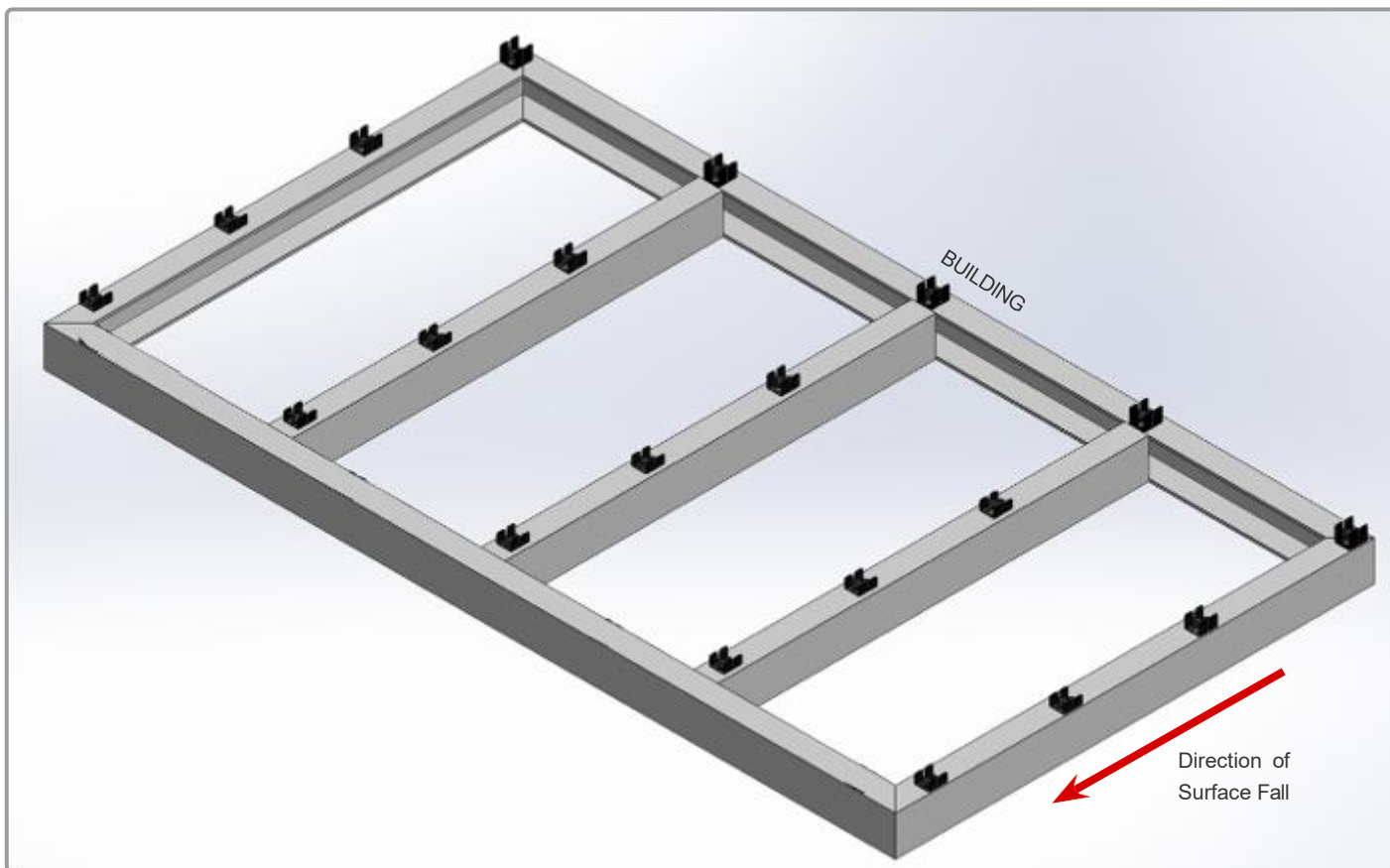

Once you have confirmed where the support joists and border drainage channel will sit, their direction, and the slope of your balcony, arrange joist brackets to support them at appropriate support centres according to joist span tables. Taller brackets should be placed at the higher points of the decking (*fig. 1*).

Fix down the bracket either using self-drilling screws or by pre-drilling and then screwing or bolting (*fig. 2*). Due to a large variance in the material type and thickness for the substrate here, EnviroBuild do not provide fixings. The hole size in the base of the bracket is 6mm.

With all brackets secured, shims can be placed into the bracket in order to set the desired height for the joist, and to create a slope. Use an appropriate combination of 1, 4, and 12mm shims to reach the desired height. Where available sloped metal shims can be placed on top of the stack to create a fixed 1:80mm slope (*fig. 3*).

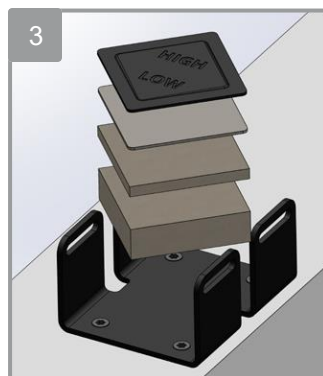
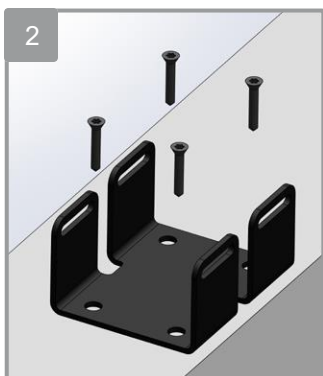
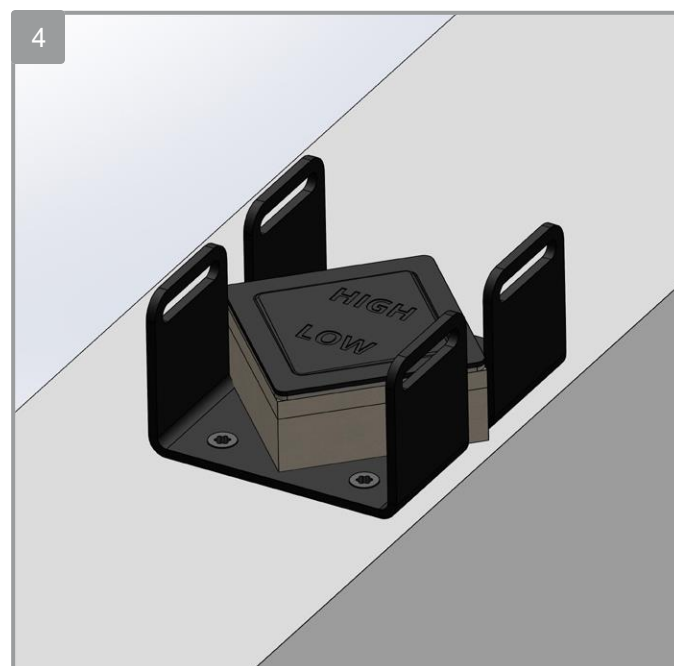
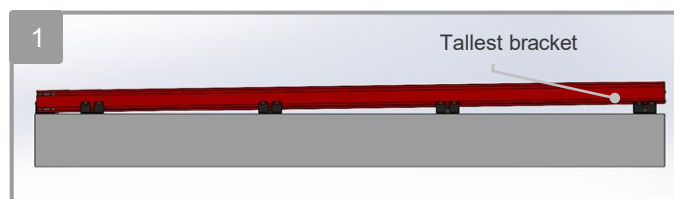

40x125mm Border Drainage Channel Assembly

Constructing the Border Drainage Channel

The next step is to construct the 40x125mm border drainage channel, to be fitted around the decking perimeter:

1. Cut the channel to desired length, and with 45 degree ends to mitre-join at corners (if required for 3-4 drainage sides). **Any cut edges or drilled holes with exposed metal should be coated to reduce the risk of long term powder coat peeling.**
2. Determine where the outlet spigot and overflow spigot will be located and pre-drill a 42-50mm holes for the 1.25" outlets to sit in. (fig. 7).
3. Fit the outlets using silicon sealant if desired, the additional outlet nut can be used to raise the overflow outlet to the desired overflow height in the drainage channel (fig. 8 & 10).
4. Connect the 45 degree channel ends. First take 2 brackets and slide into the fixing slot in the channel (fig. 5 & 6).
5. On the end of the opposing channel, use silicon sealant around all edges of the channel.
6. Slide both ends together and then fix using grub screws provided. Secure the brackets in place so the joint is solid and sealed.
7. Finally, attach end plates to close off open ends of the drainage channel. Screw the plate to the open end of the channel, and use silicon sealant to all edges (fig. 11).
8. It is prudent to check sealed areas at the point with some water to ensure water-tightness.

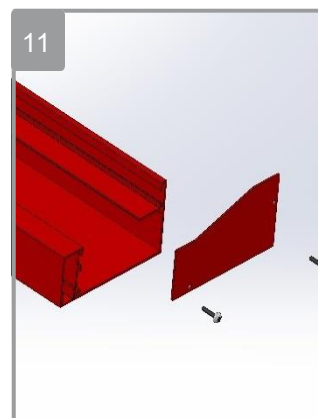
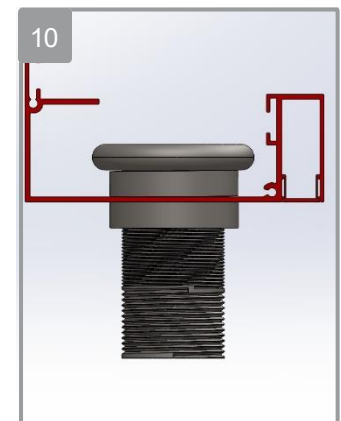
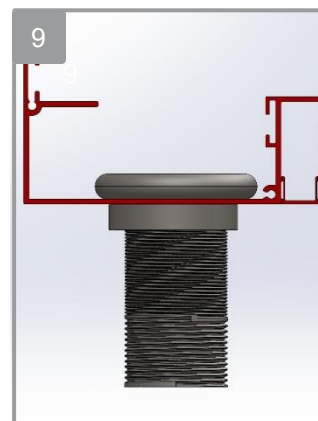
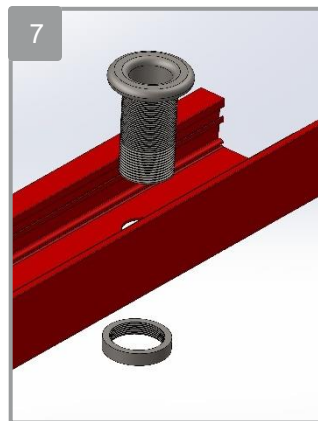
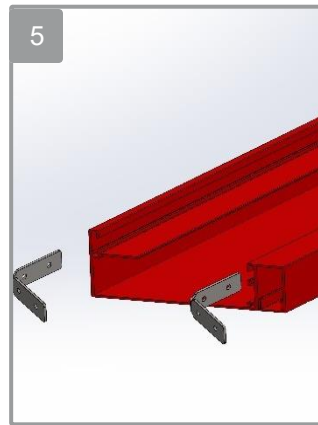

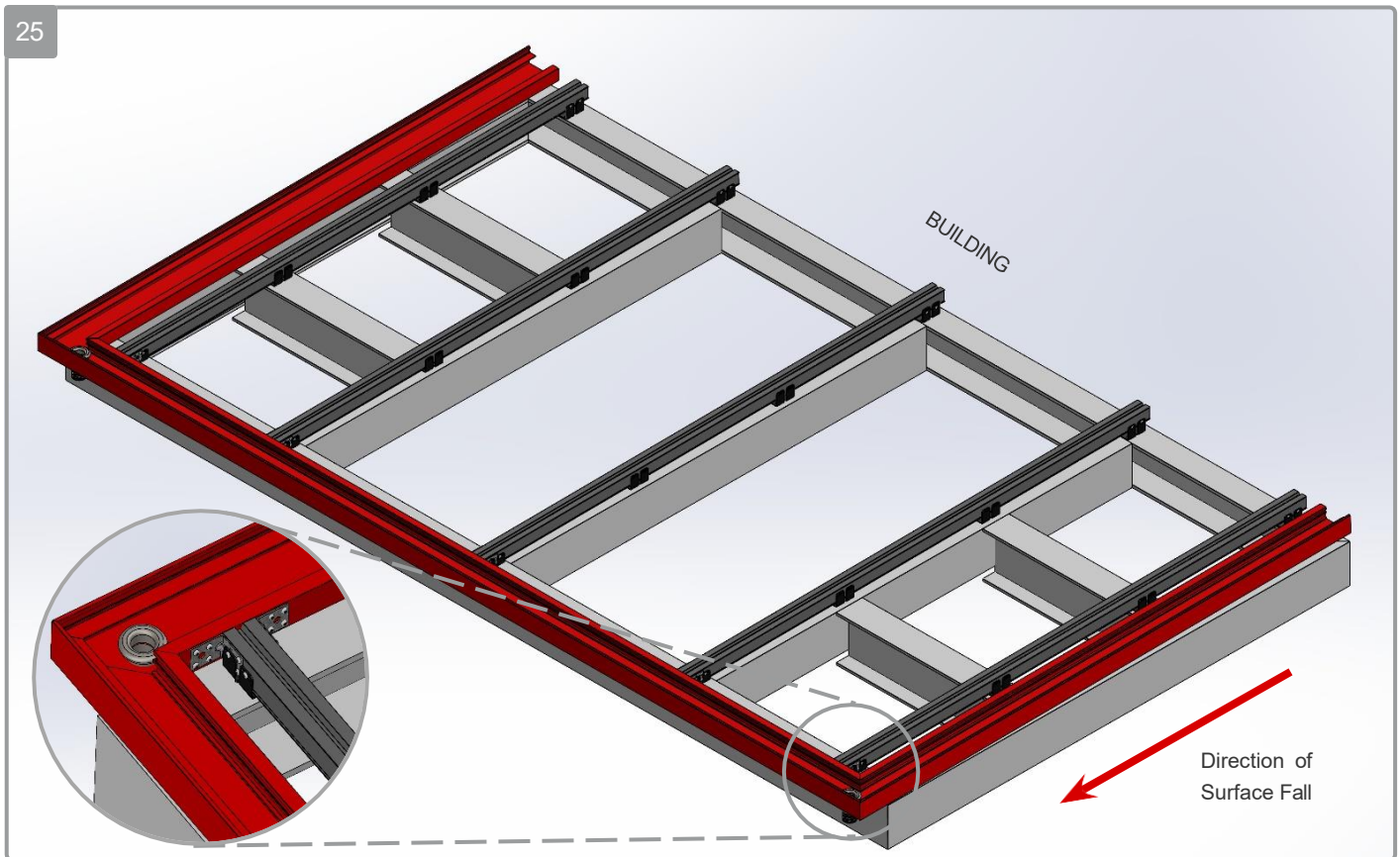

With the border drainage channel assembled (but not fixed in place), the next step is to install the support joists:

1. Cut joists to length and place into joist support brackets.
2. Double check levels and slope.
3. Fit screws through the slotted holes in the joist support brackets to fix the joists in place.
4. Where a perpendicular border drainage channel is being attached to support joists, fix 50x35mm joist L brackets either side of each joist where possible (*fig. 12*).
5. With support joists in place, position the pre-assembled border drainage channel where it would lie, flush to the support joist top surface and support in place while fixing – attached the drainage channel perpendicular to the support joist through the L brackets with Tek screws (*fig. 13*).
6. Parallel drainage channels will need to be fixed up to the deck boards to hold them in place, continue to the next page.

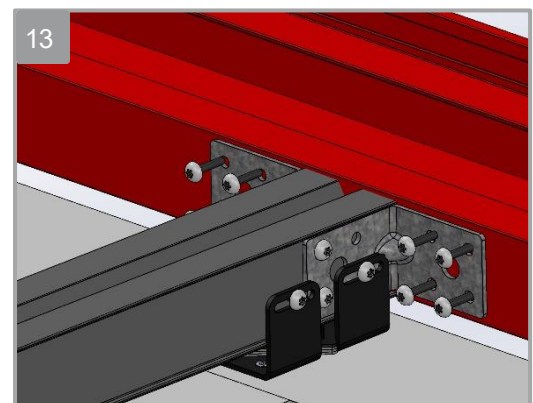
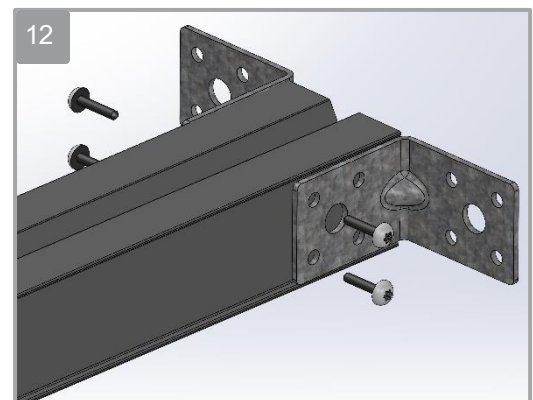

Threshold Drain Installation (optional)

The optional threshold drainage channel should be installed prior to fitting any deck boards (if you are not using this piece go to the next page and start install the deck boards from the front parallel boarder drainage channel edge):

1. Cut the threshold drainage channel to fit, such that it fits within the border drainage channel with a 10mm gap at either end.
2. Align the channel on the joists such that it sits square to the balcony, and fix down with self-drilling screws to the joists below. Use mineral washers to prevent any water egress (*fig. 14*).
3. Clip in the threshold drain cover to finish (*fig. 15*).

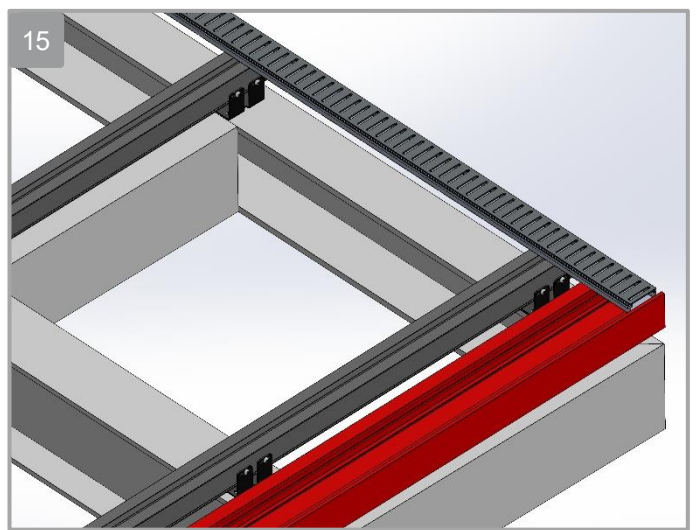
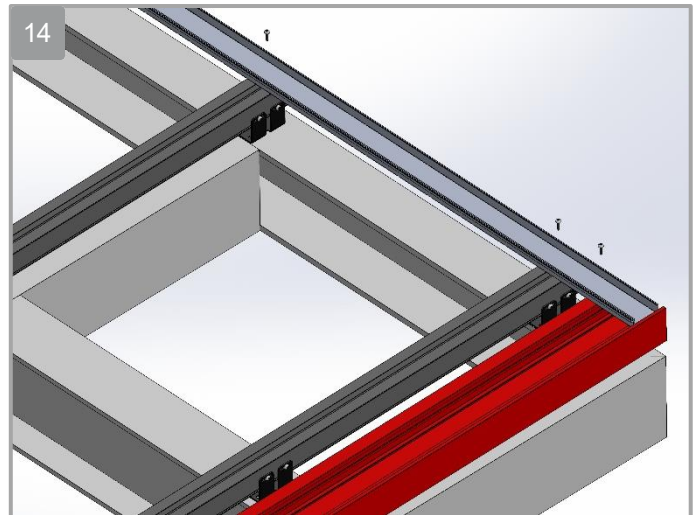

Low-Fix Deck Board Installation

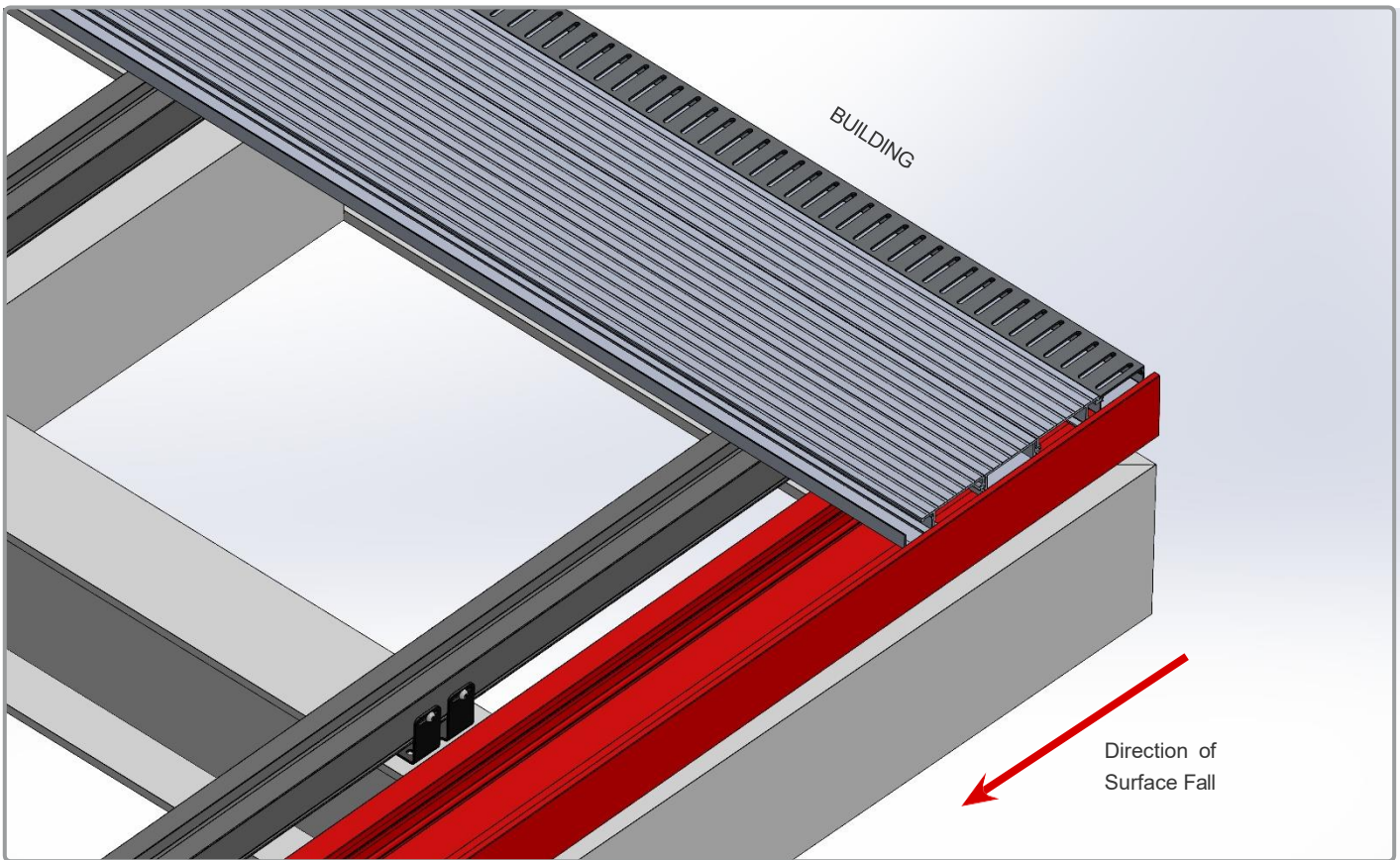

With the (optional) threshold drainage channel fitted, you can start laying the deck boards, if you have not used the threshold drainage channel, start fitting boards from the front parallel drainage channel back towards the building - skip point 2 (*fig. 20*):

1. Cut the deck boards to length to fit the space within the border drainage channel. Leave a 10mm gap at either end for drainage. **Any cut edges or drilled holes with exposed metal should be coated to reduce the risk of long term powder coat peeling.**
2. Fit the ball edge of the deck board to the upward facing socket on the threshold drainage piece (*fig. 16*).
3. Remove the deck board insert from the board if it is in place.
4. Fix the board down with suitable Tek screws, pre-drill where required to the joists below through the exposed channel (*fig. 17*). You can use mineral washers to prevent any water egress if desired.
5. Fix the boards to the perpendicular drainage channel through the exposed channel with suitable Tek screws (*fig. 19*).
6. Slot the between board drainage channel next to the first fixed board and fix the next board tightly to it, this channel shouldn't need screwing in place, but a screw can be used if desired (*fig. 18*).
7. With the board fitted, clip in the deck board inserts. Either use a rubber mallet or firmly press into place (*fig. 18*).
8. Keep fitting the boards until enough space remains for one board or less.

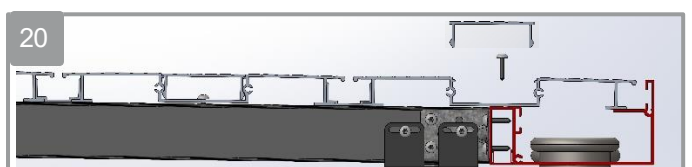
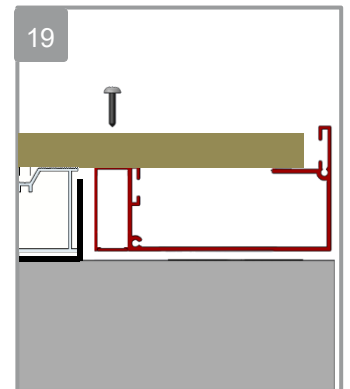
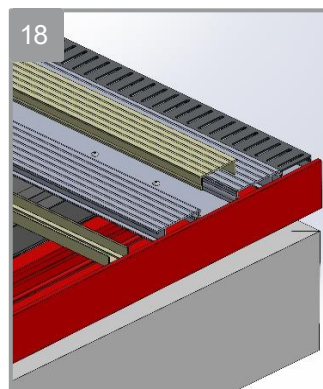
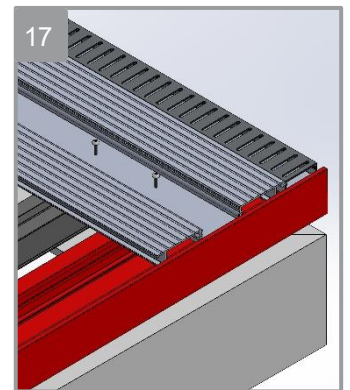
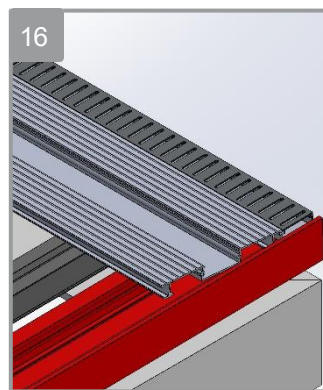

Low-Fix Deck Board Installation - Finishing

In the likely event that you need to rip a board to fit to complete your deck the clip on edging can be used to support and cover the ripped edge, whether starting from the building or balcony front edge:

1. Rip a deck board to fit the final space. Ensure to leave a enough space between the board and the border drainage channel edge to fit the clip rail edging.
2. When finishing in the boarder drainage channel (*fig. 21*), fix the clip rail on the protruding outer ledge – position so your cover sits flush to a perimeter to reduce water egress. There maybe slight variations in height, so washers can be added under the clip rail where the fixing screws are located.
3. When finishing at the building edge (*fig. 22*) fix the clip rail on the support beams so the cover would sit flush with the building to prevent water egress.
4. With all boards fitted, clip in the deck board inserts. Either use a rubber mallet or firmly press into place, use silicon seal if required between the clip rail cover and the balcony perimeter.
5. Your Low-Fix decking system is not complete! Simply connect your outlets to your desired drainage location.

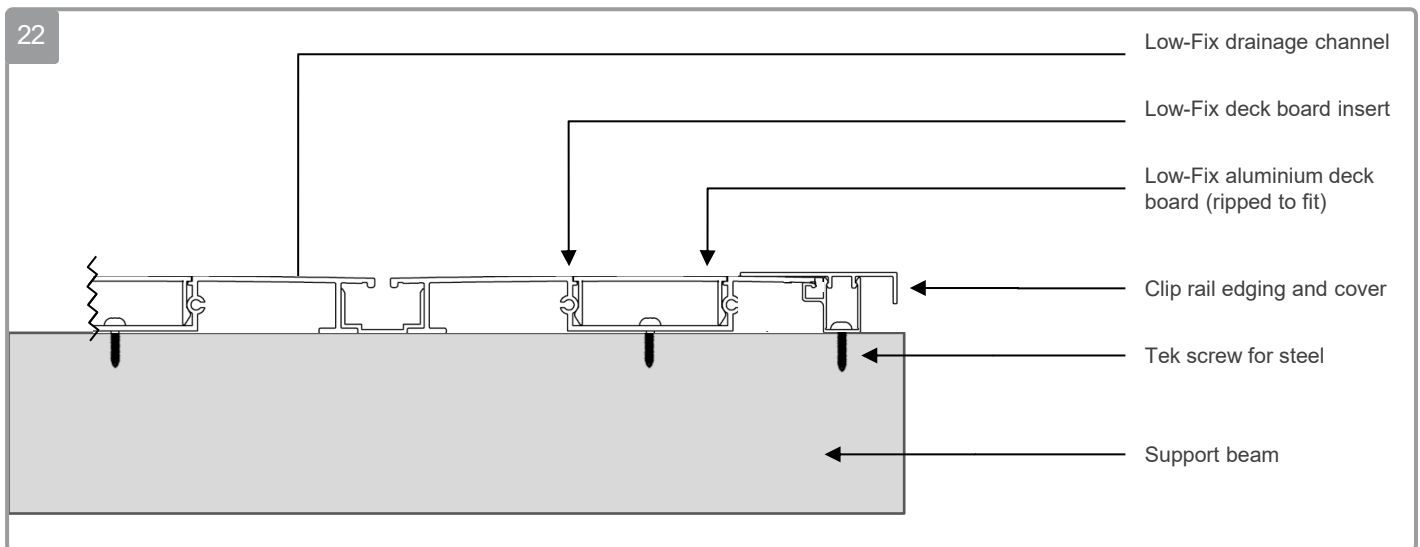
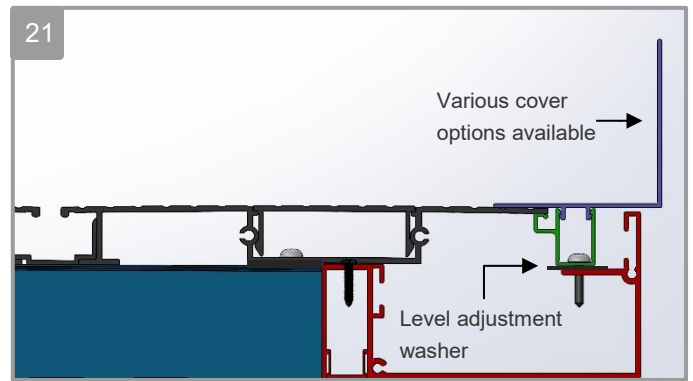

Stepwise Installation: Sloped 40x50mm Border Drainage

Pre-Installation

Low-Fix boards can create a continuous water collecting surface, with patented interlocking connection and drainage channels which are designed to mitigate the capillary effect.

The boards should be installed at a slope, forcing liquids down the continuous surface and into drainage channels either at the decking surface edges or underneath.

The 40x50mm Border Drainage Channel system provides a complete edge drainage solution, primarily for use on projecting balconies. Slots within the channel allow for easy fixing and assembly, reducing the need to screw down through the channel which can impact water-tightness.

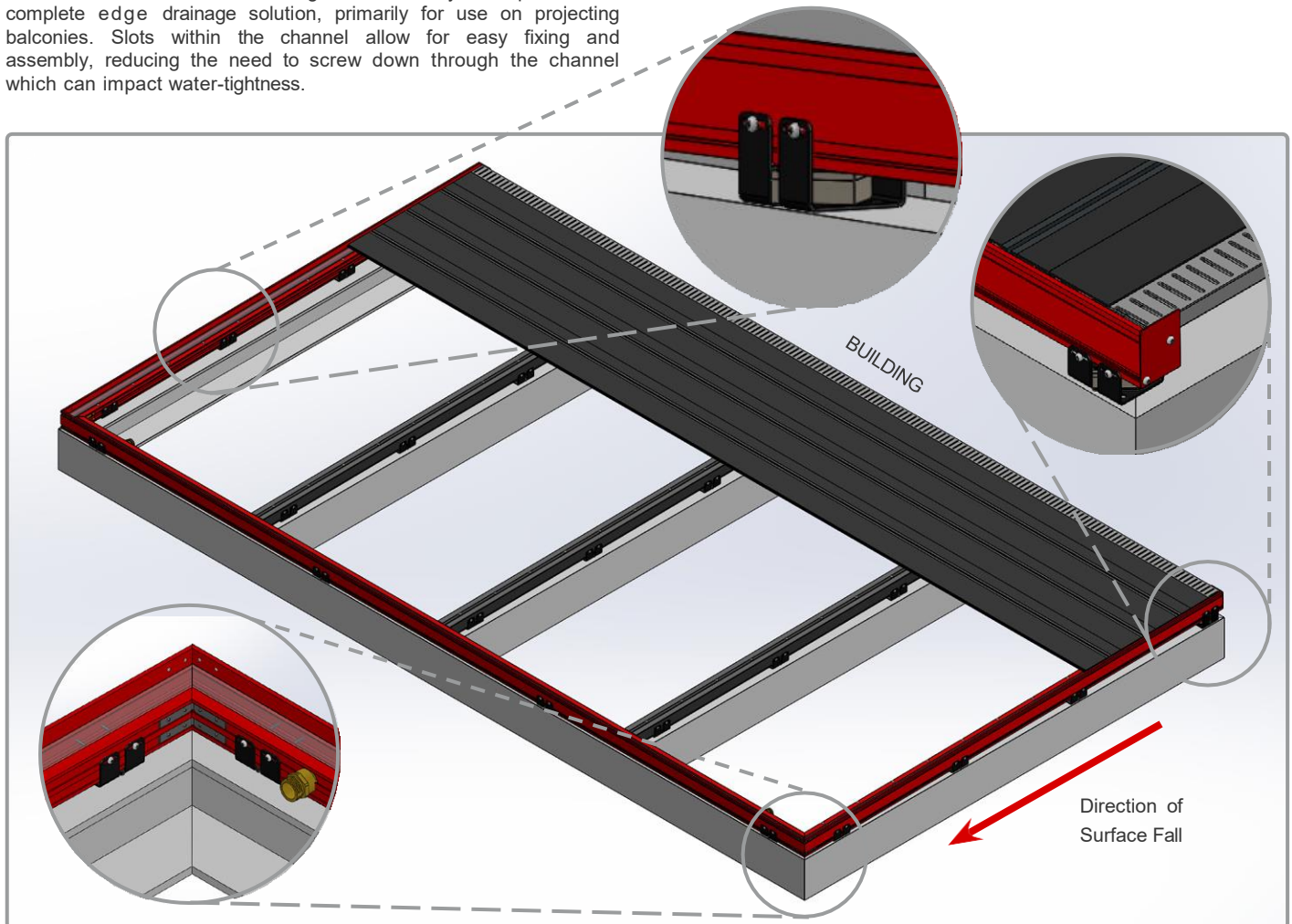

Pre-Installation Checks

Before starting your installation, a few key considerations should be confirmed:









1. Direction of surface slope - We recommend a 1:80 fall away from the building on the decking layer.
2. Direction of your boards - The system above shows how to install based on boards running widthways (parallel to the building). If your balcony is >6.0m wide, we recommend running the boards depthways to avoid the need for butt-gaps, or alternatively longer boards (bespoke order, up to 6.5m) can be purchased on a longer lead time.
3. Water collection point - Best practice will see water collected at the lowest point of the border drainage channel system. This is likely to be the furthest point from the building. Pipes can be connected to 3/4" BSP spigot(s).
4. Water overflow point - Opposite to the above an overflow spigot should be placed at the highest point in the border drainage channel system, to allow water a means of escape if the primary outlet becomes blocked.

Stepwise Installation: Widthways Low-Fix Board Installation

Parts and Equipment Check

It is essential to check you have all the parts required before installation, as per below:

Parts Required

40x50mm Border drainage channel	
Channel end plates	
Channel mesh	
Spigots	
Nuts for spigots	
90 degree joining brackets	
Flat joining brackets (only when balcony width is >3.6m)	
Slope-creating joist brackets	
Bracket shims	
Deck boards	
Deck board inserts	
Between board drainage channels	
Threshold drainage channel and cover	
40x50mm Aluminium joists	
Self-drilling fixing screws	

Equipment Required

Appropriate PPE
Impact driver
Hand drill with 30mm metal drill bit
Chop saw with metal cutting blade
Metal snips
Allen key - 2.5mm

Joist Bracket Fixing

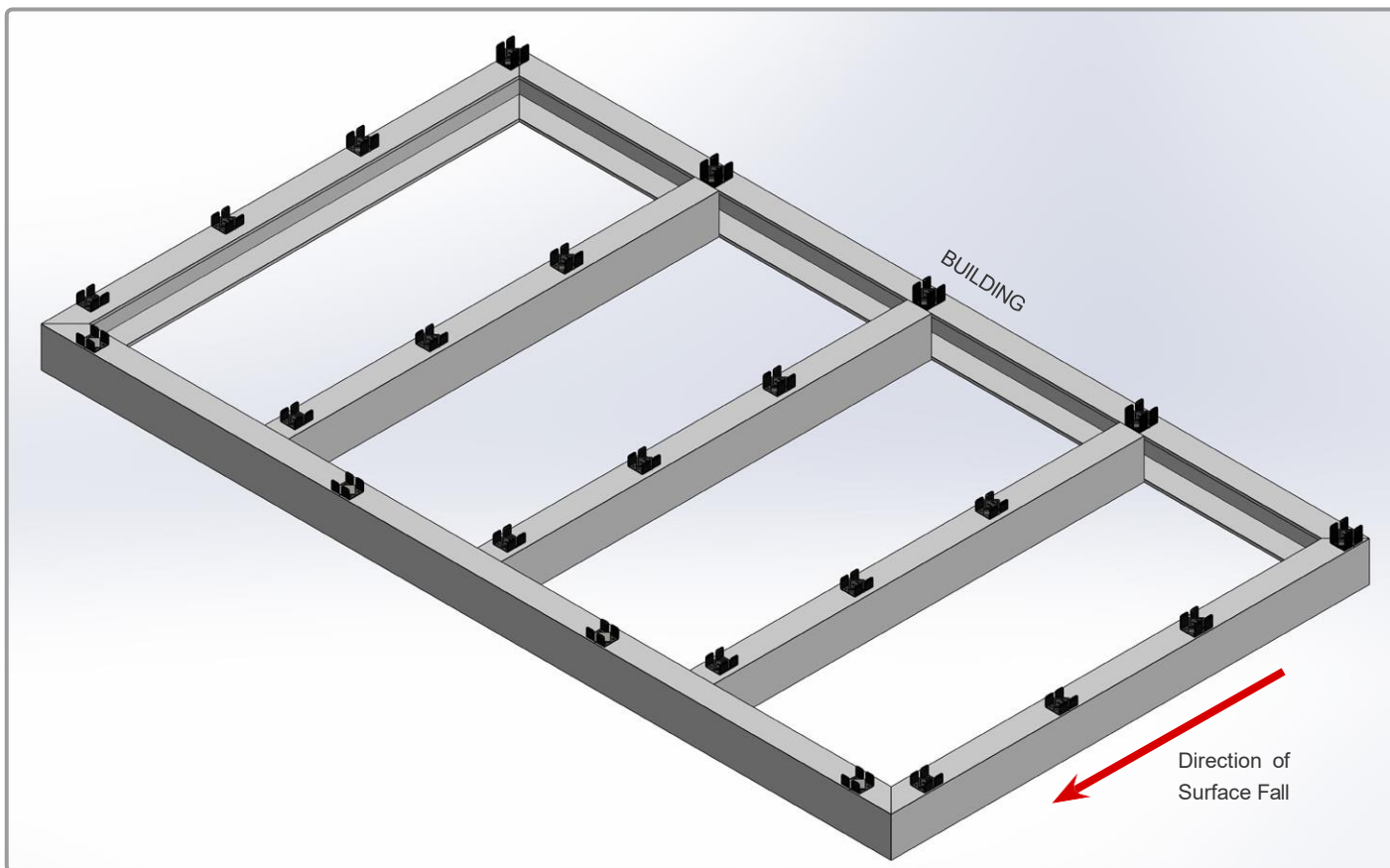

Once you have confirmed where the support joists and border drainage channel will sit, their direction, and the slope of your balcony, arrange joist brackets to support them at appropriate support centres according to joist span tables. Taller brackets should be placed at the higher points of the decking (*fig. 11*).

Fix down the bracket either using self-drilling screws or by pre-drilling and then screwing or bolting (*fig. 12*). Due to a large variance in the material type and thickness for the substrate here, EnviroBuild do not provide fixings. The hole size in the base of the bracket is 6mm.

With all brackets secured, shims can be placed into the bracket in order to set the desired height for the joist, and to create a slope. Use an appropriate combination of 1, 4, and 12mm shims to reach the desired height. Where available sloped metal shims can be placed on top of the stack to create a fixed 1:80mm slope (*fig. 13*).

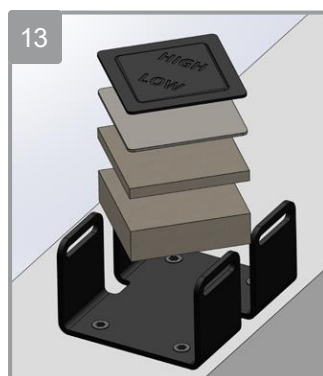
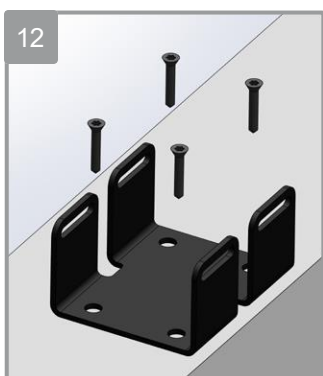
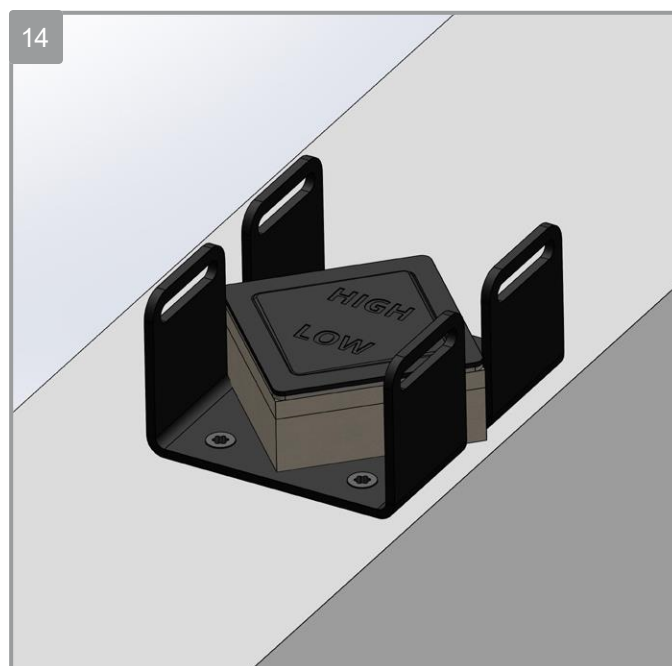
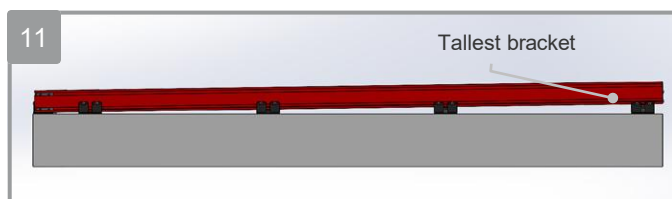

40x50mm Border Drainage Channel Assembly

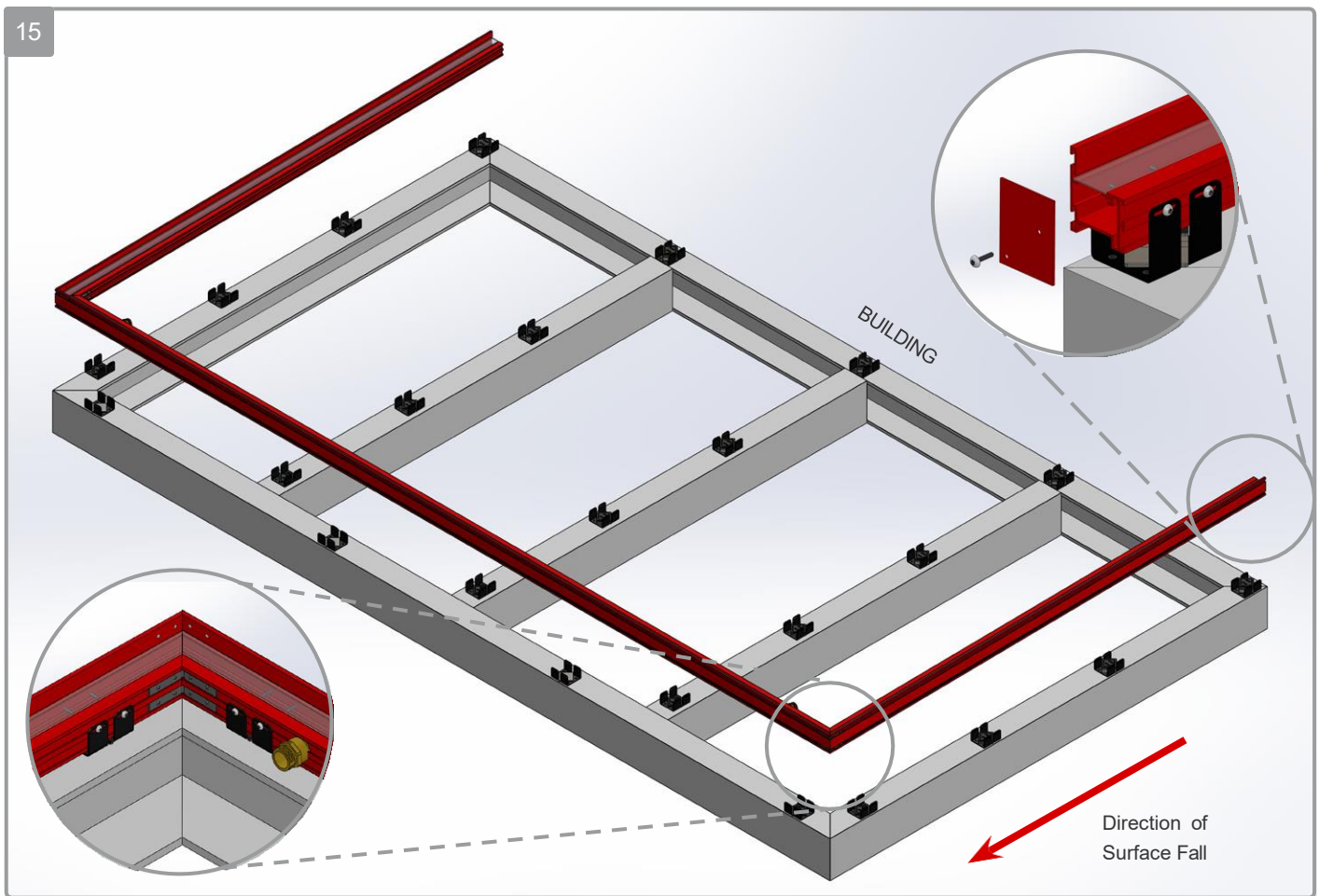

Constructing the Border Drainage Channel

The next step is to construct the border drainage channel, to be fitted within the brackets laid out previously:

1. Cut the channel to desired length, and with 45 degree ends to mitre-join at corners. **Any cut edges or drilled holes with exposed metal should be coated to reduce the risk of long term powder coat peeling.**
2. Determine where the outlet spigot and overflow spigot will be located. Ensure they are positioned min. 60mm from a corner joint to avoid joining brackets, and away from joist brackets previously laid out.
3. Using the guide groove on the centre of the border channel side, pre-drill 30mm holes for the spigots to sit in. Take care not to over-drill and pierce the internal walls (*fig. 16*).
4. Slide the spigot nuts down the slot in the side of the channel (*fig. 16*). Do not fix the spigot yet if you have 90 degree joining brackets still to fit.
5. Slide 90 degree joining brackets as needed, to later join the border drainage channel to balcony joists.
6. Screw the spigot into the nut and use silicon sealant around the hole to ensure a water tight connection.

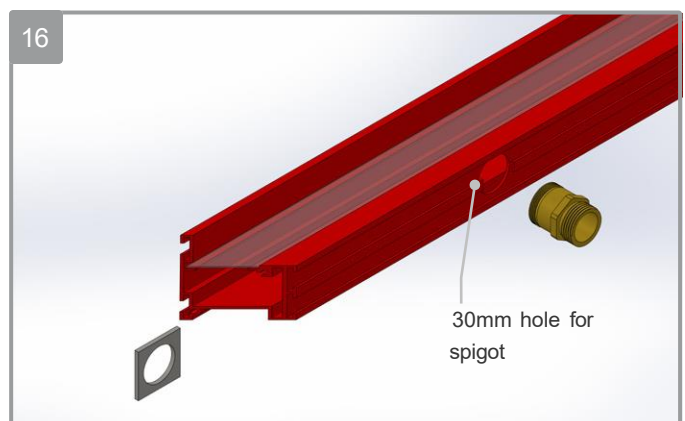

40x50mm Border Drainage Channel Assembly

7. Connect the 45 degree channel ends. First take 4 brackets and slide into the fixing slot in the channel (*fig. 17*).
8. On the end of the opposing channel, use silicon sealant around all edges of the channel (*fig. 19*).
9. Slide both ends together and then fix using grub screws provided (*fig. 18*). Secure the brackets in place so the joint is solid and sealed.
10. Finally, attach end plates to close off open ends of the drainage channel. Screw the plate to the open end of the channel, and use silicon sealant to all edges (*fig. 20*).
11. It is prudent to check sealed areas at the point with some water to ensure water-tightness.

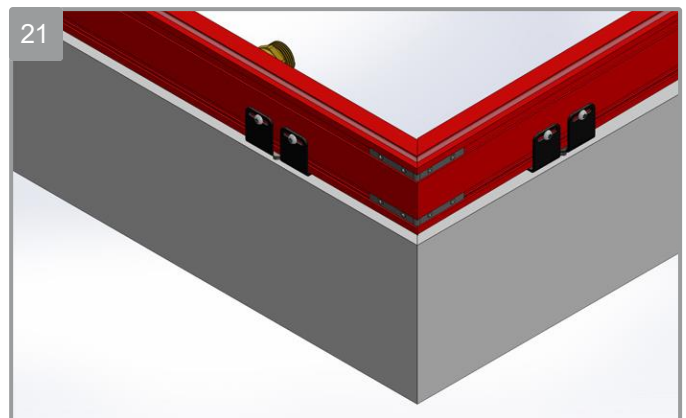
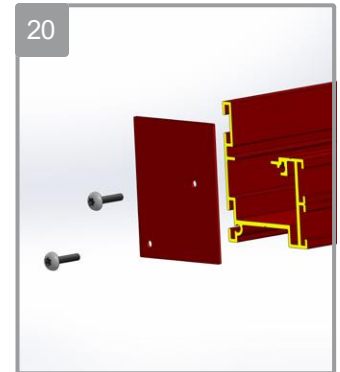
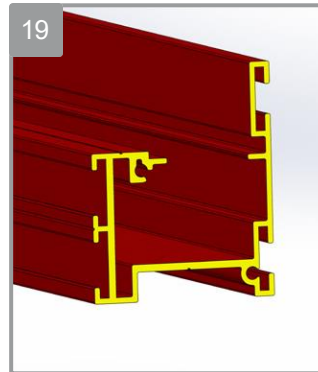
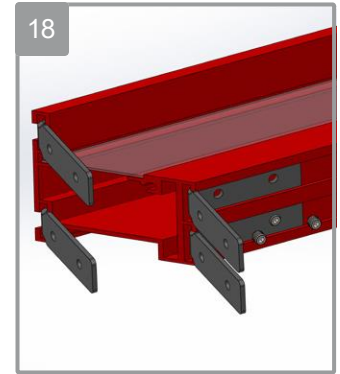
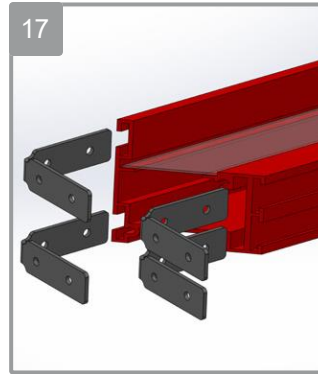

40x50mm Border Drainage Channel Installation

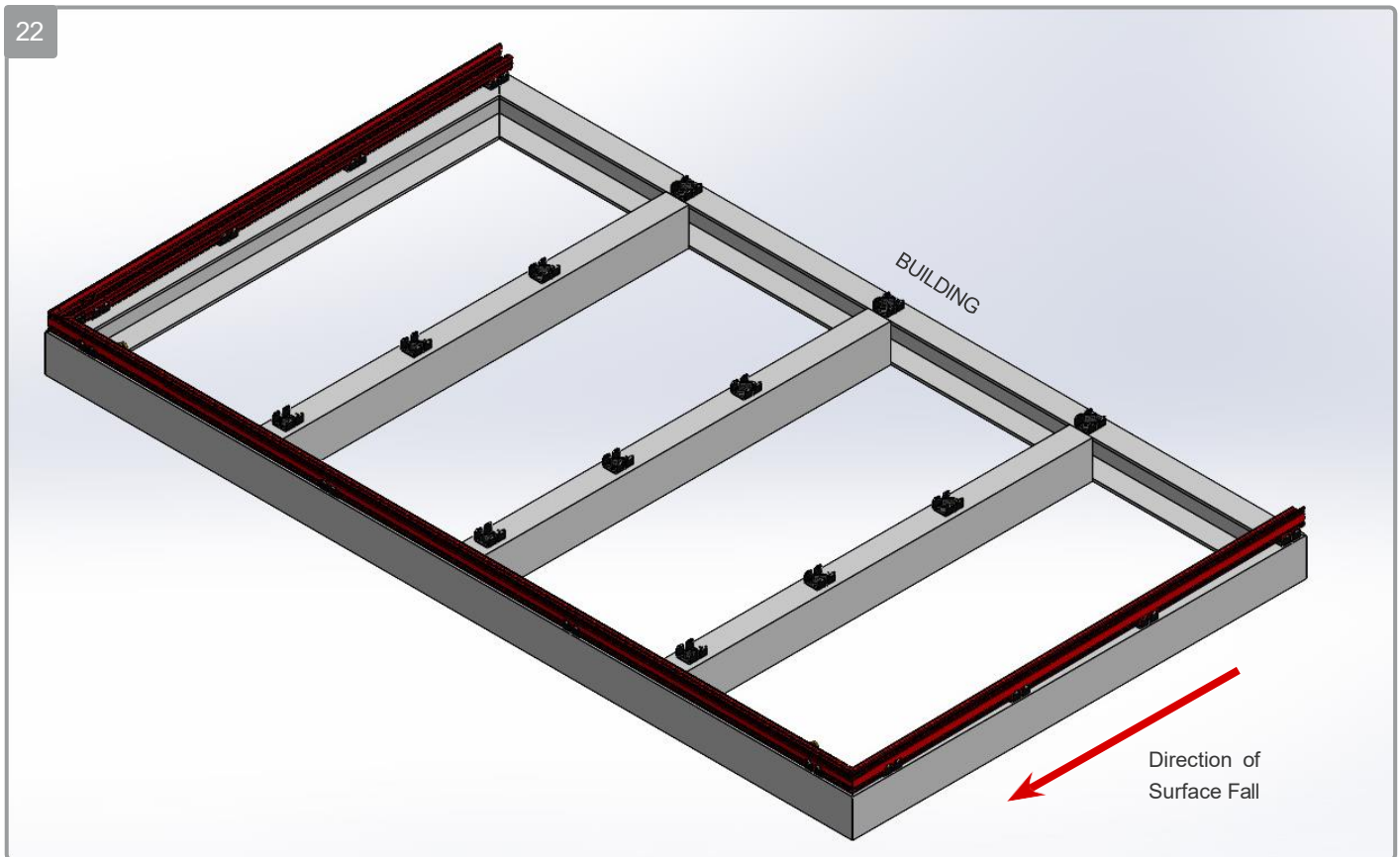

Once the border drainage channel is fully assembled, it can be placed into the joist bracket system:

1. Ensure you have the required slope to assist water moving to the outflow area (as per 'Joist Bracket Fixing', see page 11).
2. The channel does not need to be screwed down, meaning less penetrating screws and less risk of leakage. If you want to fix it in place, you can fix panhead screws through the joist bracket slots and into the side of the drainage channel (fig. 23).
3. With the channel in position, place the 1mm drainage mesh on top of the entire length of drainage channel (fig. 24). Use snips to cut to size.

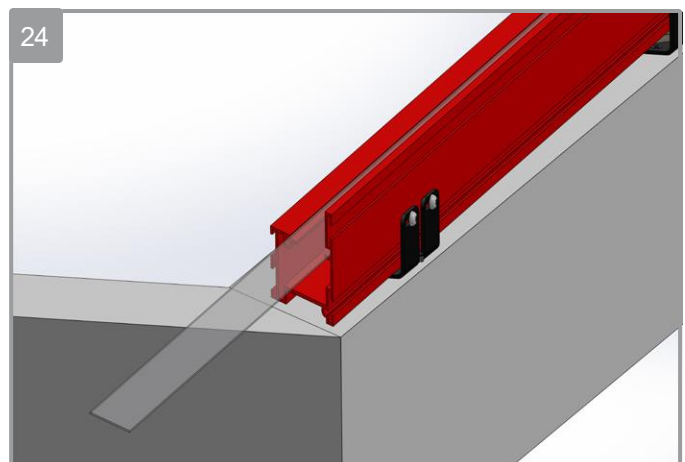
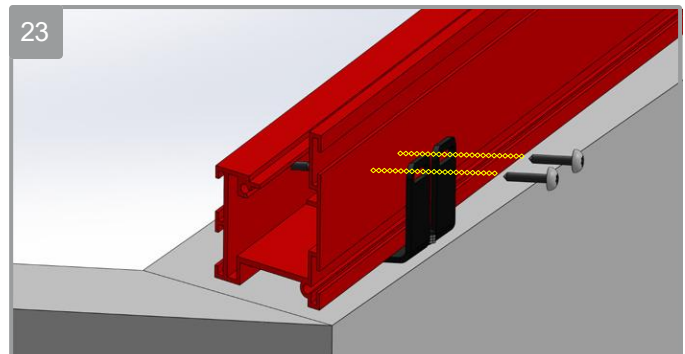

25

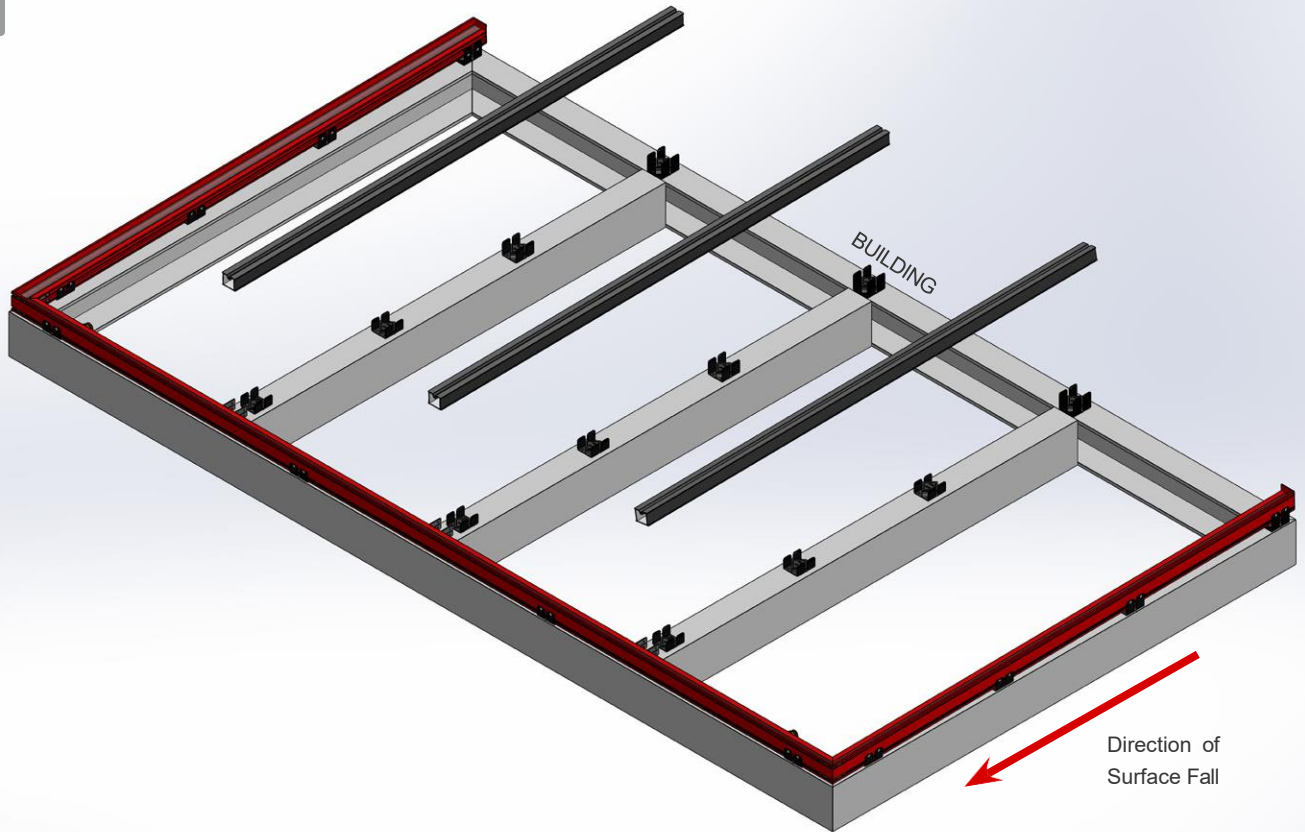

With the border drainage channel in place, the next step is to install the support joists:

1. Cut joists to length and place into joist brackets.
2. Double check levels and slope.
3. If the perpendicular border drainage channel is being attached to support joists using 90 degree brackets, slide these in place either side of each joist (*fig. 26*).
4. Fit screws through the slotted holes in the joist brackets to fix the joists in place (*fig. 23*).
5. If using 90 degree brackets (as per step 3), fix these to the side of the drainage channel using grub screws (*fig. 27*). Regular screws can be used to fix to the joists.

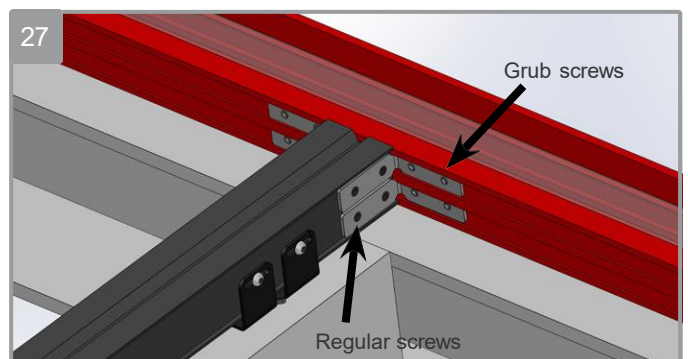
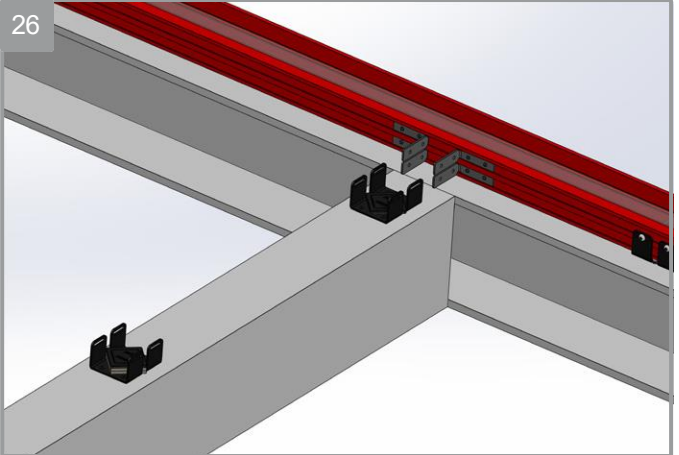

Threshold Drain Installation

The threshold drainage channel should be installed prior to fitting any deck boards:

1. Cut the threshold drainage channel to fit, such that it fits within the border drainage channel with a 10mm gap at either end (*fig. 28*).
2. Align the channel on the joists such that it sits square to the balcony, and fix down with self-drilling screws to the joists below. Use mineral washers to prevent any water egress (*fig. 29*).
3. Clip in the threshold drain cover to finish (*fig. 30*).

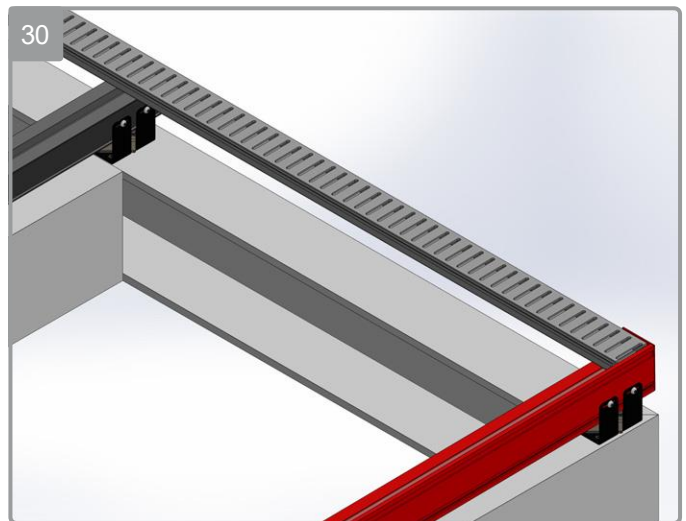
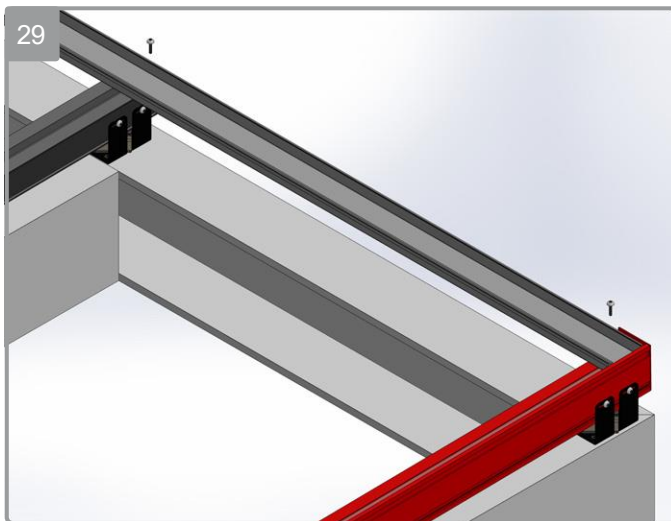
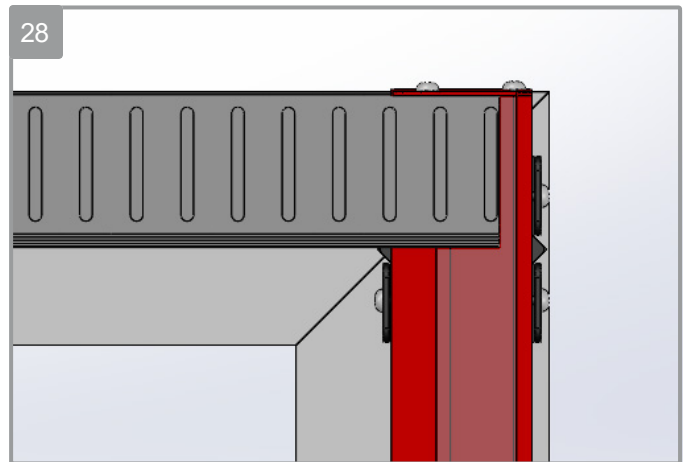

Low-Fix Deck Board Installation

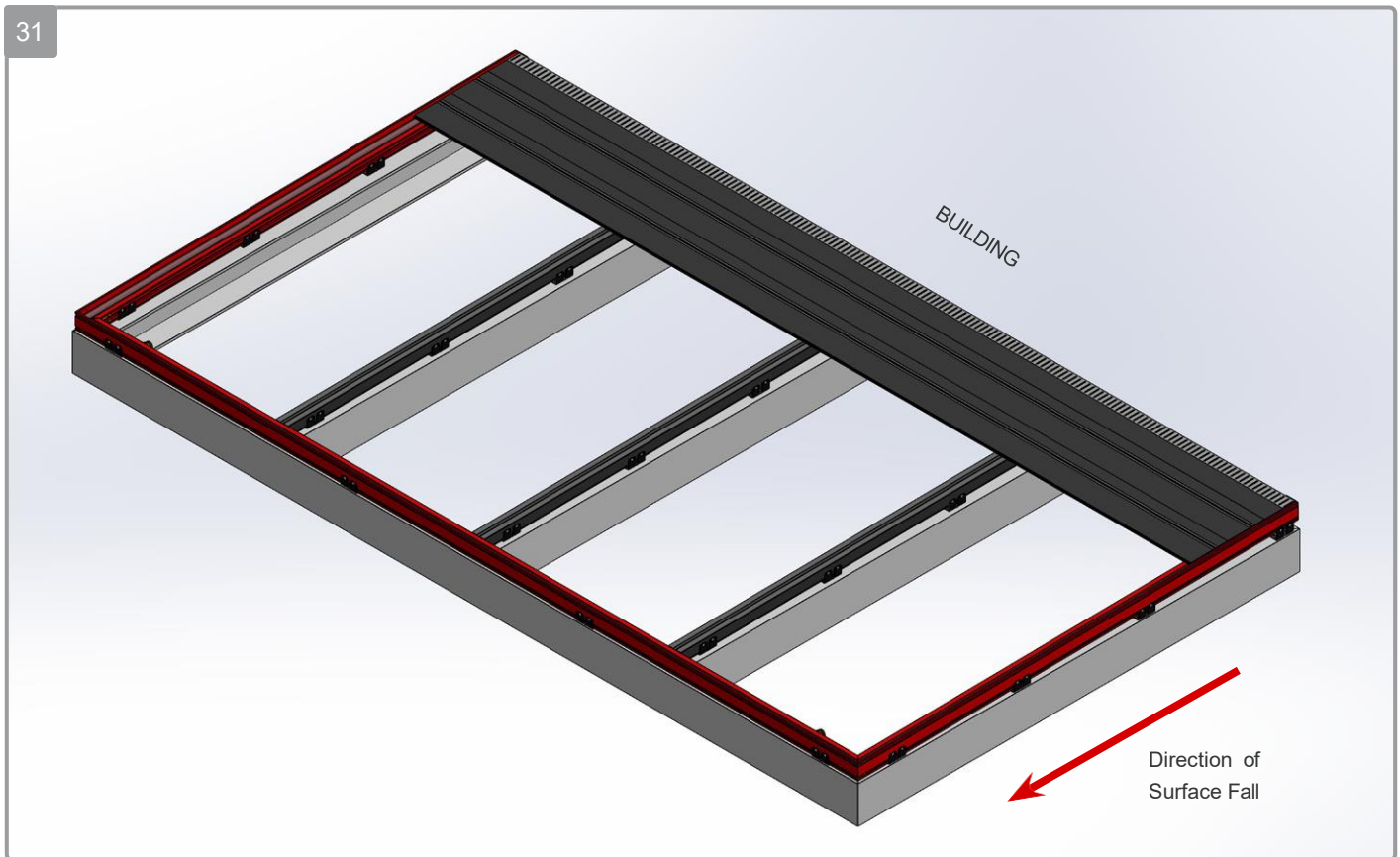

With the threshold drainage channel fitted, you can start laying the deck boards:

1. Cut the deck boards to length to fit the space within the border drainage channel. Leave a 10mm gap at either end for drainage. **Any cut edges or drilled holes with exposed metal should be coated to reduce the risk of long term powder coat peeling.**
2. Fit the ball edge of the deck board to the upward facing socket on the threshold drainage piece (*fig. 32*).
3. Remove the deck board insert from the board if it is in place.
4. Fix the board down with suitable Tek screws, pre-drill where required to the joists below through the exposed channel (*fig. 33*). You can use mineral washers to prevent any water egress if desired.
5. Slot the between board drainage channel next to the first fixed board and fix the next board tightly to it, this channel shouldn't need screwing in place, but a screw can be used if desired.
6. Keep fitting the boards until enough space remains for one board or less.
6. Rip a deck board to fit the final space. Ensure to leave a 10mm gap between the board and the border drainage channel edge (*fig. 34*).
7. With all boards fitted, clip in the deck board inserts. Either use a rubber mallet or firmly press into place (*fig. 35*).
8. Your Low-Fix decking system is not complete! Simply connect your spigots to your desired drainage location.

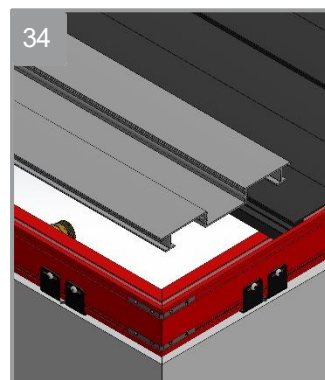
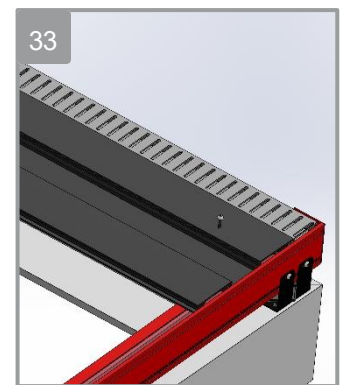
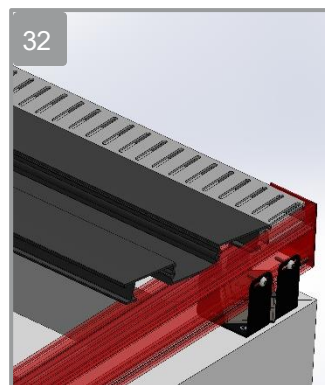

CARE & MAINTENANCE

- **How should I prevent scratching deck boards?**
Ensure that all furniture used on A-Class systems have soft felt pads under their legs. Any scratches to the metalwork should be coated to prevent paint peeling from those areas.
- **How can I fix light chips or scratches?**
Light chips or scratches which leave exposed the base metal should be carefully covered by applying an appropriate zinc rich primer, followed by a topcoat finish in a matching acrylic based paint. Ensure all areas are cleaned with PW3 panel wipe to remove any grease prior to re-coating. It is strongly recommended that the surrounded area should be fully protected and masked off if using spray paint.
- **How often should I clean my deck boards?**
At regular intervals but at the very least they should be cleaned twice a year as excess dirt can cause damage.
- **How should aluminium deck boards be cleaned?**
To clean the structure, a solution of warm soapy water and a lint-free cloth should be used. The structure should then be rinsed thoroughly with water. No form of abrasive should be used at any time. All concentrated cleaners should be diluted as per the manufacturer's instructions. Never use bleach, solvents, abrasive paste or cream cleaners as they could damage the surface of your decking.

To maximise the life of the painted surface, it is highly recommended that no cleanser that contains chlorinated solvents, ketones or esters is used. These will cause the paint to soften.
- **Can a pressure washer or steam cleaner be used?**
It is not advised to use pressure washers or steam cleaners to clean aluminium deck boards.
- **How can I fix larger areas of damage, coating breakdown or vandalism?**
The area should be sanded so that the edges are smoothed to allow for feathering in using P320 grade fine sandpaper (to create a smoother transition from the old paint to the new). A zinc rich primer should be brushed or sprayed onto the area and a topcoat should then be applied, in a similar manner.
- **How can I remove graffiti?**
Graffiti should be removed by a specialist contract cleaner or by using a "T-Cutting" compound. It is not recommended to use any solvents, abrasive cleaners or other chemicals to clean the surface at any time.

INSTALLATION

- **How do I cut aluminium decking boards and bearers?**
A saw blade suitable for aluminium materials should be used. Preferably use one with a blade suited to non-ferrous materials and for profiles of a suitable thickness. Blades designed for cutting non-ferrous materials usually have a special grade of carbide for aluminium, a triple chip top grind and a zero or negative hook angle. There are ways to cut aluminium materials with blades designed to cut wood, however this is not recommended.

A circular saw or table saw can be used however the preferred method is using a miter saw. Ensure the aluminium material is sufficiently fixed with a clamp in order to prevent damage to the blade or the user. You will get better results and a longer blade life if you use a lubricant (a wax stick or WD-40 is easy to apply while the blade is spinning).
- **Does cutting aluminium leave burrs?**
Any small burring which may occur can be removed simply by using sandpaper and a pair of safety gloves.
- **How long will the powder coating last?**
Under normal use and conditions, the powder coating should last for over 10 years, in coastal regions you need to ensure you have Seaside version of the coating specified. Areas of exposed cuts, mark, scratches to the metal are not covered under warranty and peeling from these points is possible within this time if left untreated.
- **How can noise dampening be improved?**
A layer of EPDM membrane could be used between the aluminium decking and the bearer. This requires checking with building control.



Visit envirobuild.com

Find us on:

 /envirobuildcom

  @envirobuild

29 Pear Tree St,
London,
EC1V 3AG