



CI/SfB L519 + L529

Xh4

eltherington
architectural solutions
Innovation | Performance | Facades

Column casings

CC1

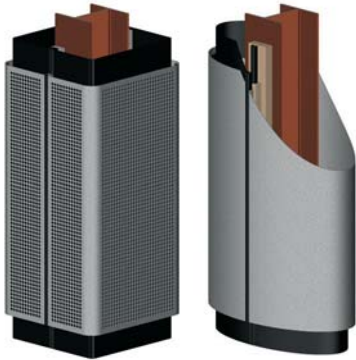

Specification guide

Specification guide

Column casings

Eltherington are leaders in the manufacture of high quality column casing systems. From simple shapes, through to complex column casings, our precision manufacturing processes are able to bring your designs to life.

We manufacture column casings in a wide selection of materials including aluminium, steel and copper through to Rimex, Corten and zinc, to name just a few. Our column casings have been used on a number of high profile projects such as the Edinburgh International Conference Centre and Birmingham New Street Station.

Eltherington column casings are non-combustible (Class O), durable, low maintenance and aesthetically pleasing. Our team can help you with design and specification.

Innovation and service

Eltherington has been providing innovative architectural solutions to the construction industry for over 50 years. Our 6 acre, state of the art production

facility allows us to take on board specialist architectural metal work projects of any scale.

We manufacture a wide range of other external architectural systems including Bull Noses, Fascia and Soffits, Guttering and Rainscreen Cladding.

CPD

Eltherington offer RIBA accredited CPD seminars that can be presented to you or your team on request.

Technical support

Whatever product you are looking to specify, our skilled technical team will be able to provide you with support and advice at all stages of the project. We offer a full suite of 2D and 3D design services.

Compliance

Our UK-based manufacturing facilities are able to work to the exacting tolerances required to help you meet ever more stringent building legislation.

Benefits

- Wide range of materials
- Simple through to complex shapes
- Interior and exterior columns
- Hide mechanical and electrical services
- Quick and easy to install
- UK manufactured
- Does not support combustion and can meet the requirements laid out in BS476 Part 7. Class O non combustible. BS EN 13501-1.



Eltherington architectural solutions

Stainless steel column casing at Whitehall Road, Leeds.



Parapets



Canopies



Rainscreen cladding



Specialist fabrications



Fascia and Soffits



Internal cladding

Angular column casing (Perforated)

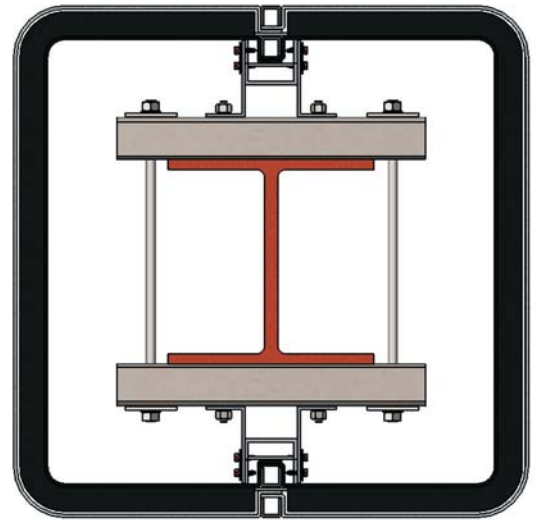
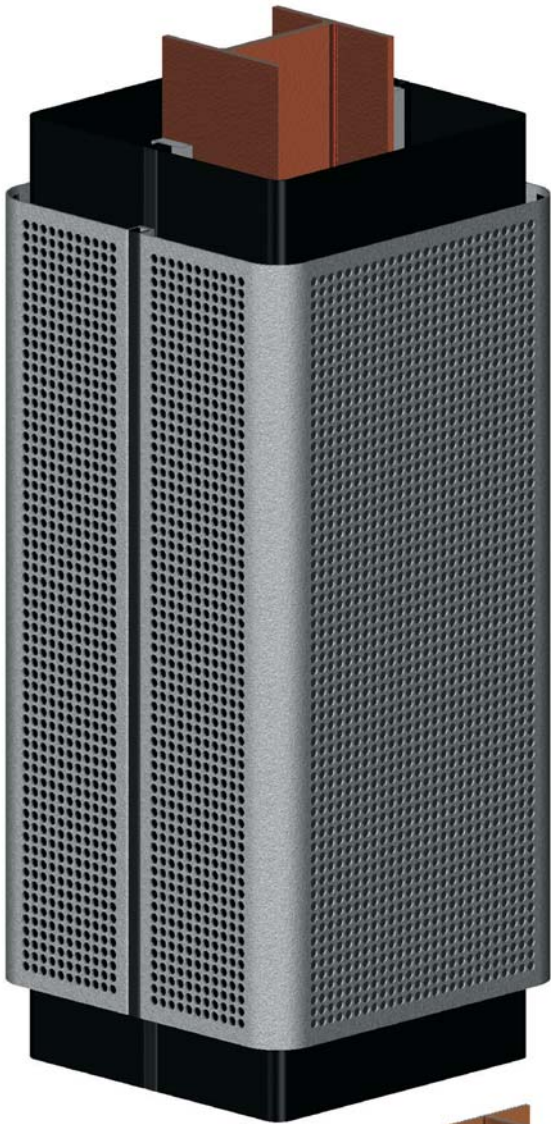

1st Fix Collar with Restrictor

2nd Fix Collar with Restrictor

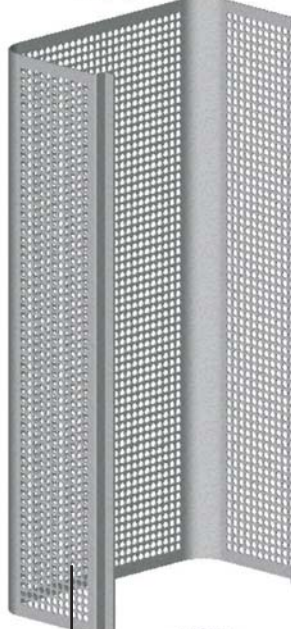
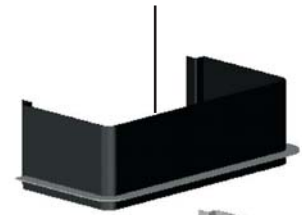
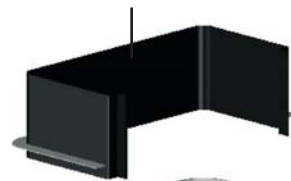
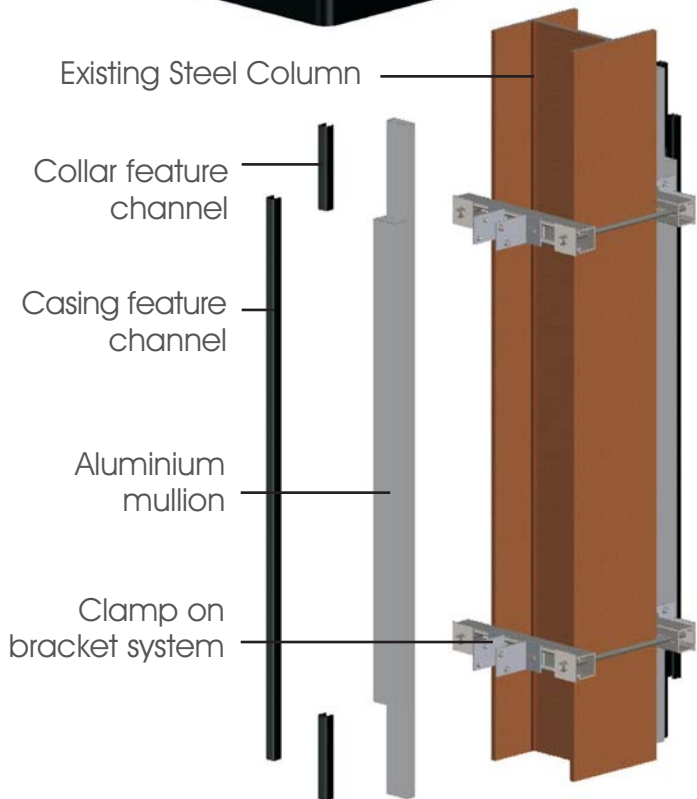

1st Fix Casing

2nd Fix Casing

Specification guide

Bespoke column casing

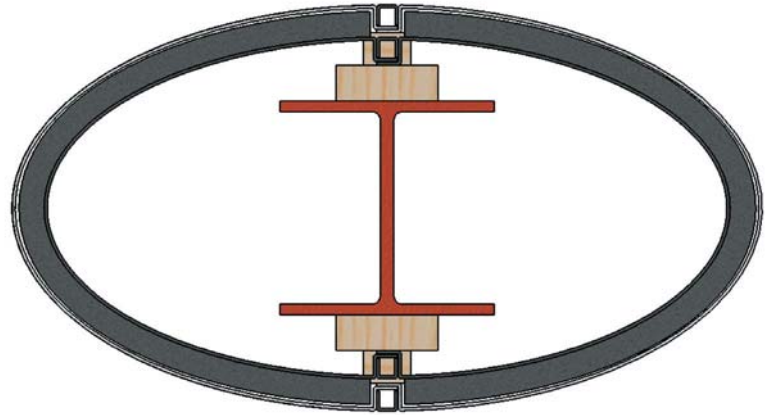

1st Fix Collar with Restrictor

2nd Fix Collar with Restrictor



Existing Steel Column



Collar feature channel

Casing feature channel

Timber Batten

Timber Batten

1st Fix Casing

2nd Fix Casing

Circular column casing

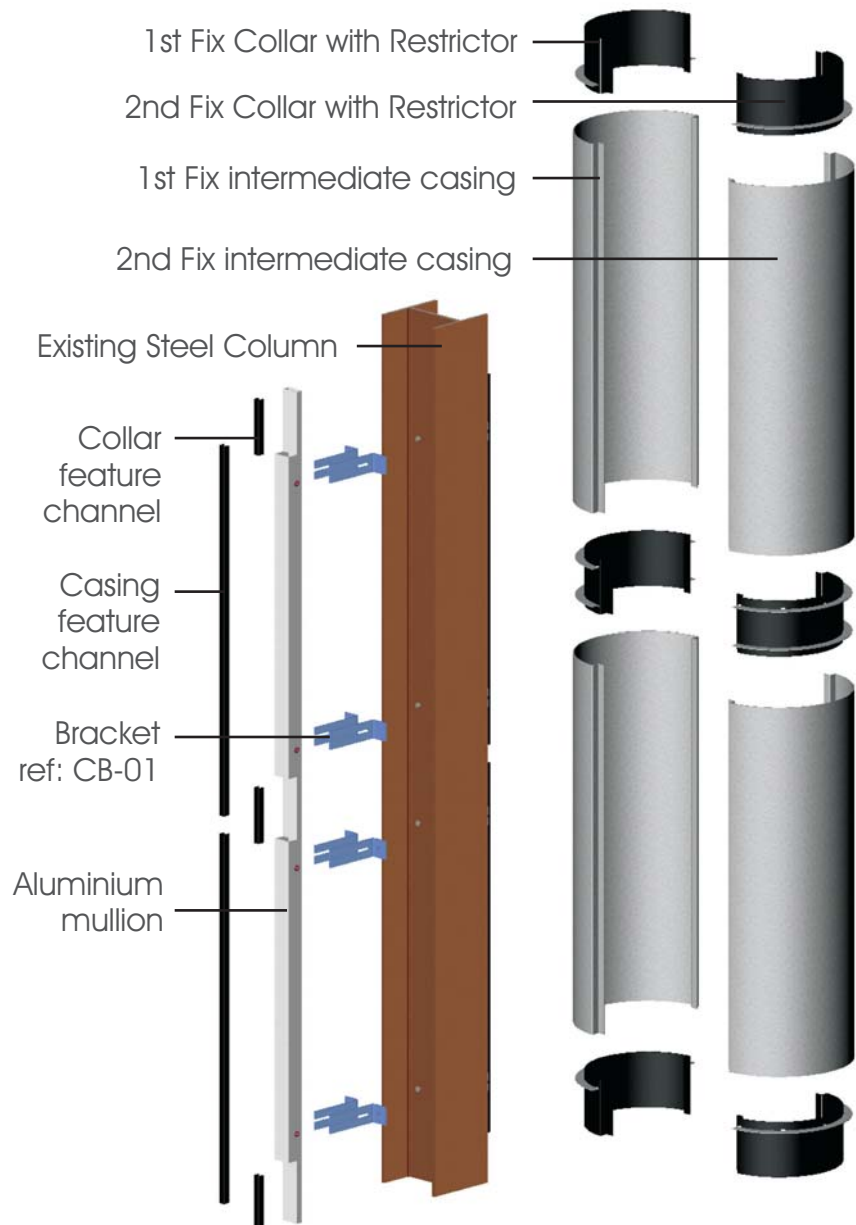
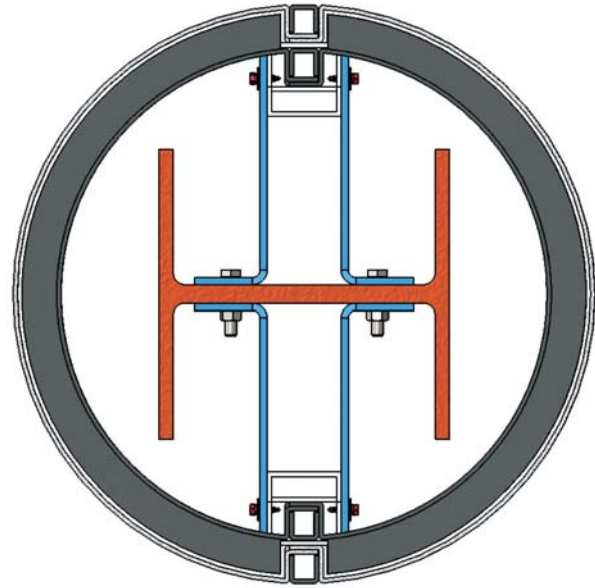

Column casings

Materials and finishes

Aluminium	Finish
Polyester powder coated	Standards
Polyester powder coated	Metallic & textured
Pre-coat	Standards
Pre-coat	Metallic & Chameleon
Anodised	Natural
Anodised	Anolok bronze
Anodised	Anolok black
Anodised	Anolok Blue Grey
Anodised	Anolok gold
Natural plain	Mill finish
Aluminium composite (ACM)	Reynobond
Aluminium	Rimex
Various	Perforated
Various	Slotted

Stainless Steel	Finish
304 / 14301	Satin polished
316 / 14401	Satin polished
Industrial	Shot peened/blasted
Unique	Circular polish
Natural plain	2B mill finish
Pattern	Rimex
Industrial	Granex
Arcelor Mittal	Uginox TT
Various	Perforated
Various	Slotted

Steel	Finish
Galvanised	PPC
Galvanised natural plain	Mill finish
Zinc	PPC
Zinc natural plain	Mill finish
Pre-coat	Dobel Plastisol
Mild steel	PPC
Corten steel natural plain	Mill finish
Various	Perforated
Various	Slotted

Other	Finish
Rimex Colourtex	Various
Rimex S/S Vortex	Various
Copper natural plain	Mill finish
Aluminium pre-coat Reynolux	Various
Zinc material	Mill finish
Aluminium pre-coat zinc	Grey
Aluminium pre-coat FF2	PVDF coated
Brass	Polished

Sustainability and the Green Guide

Eltherington is committed to sustainable manufacturing leadership in all areas of its business, including recycling, reduction of waste and saving energy.

Showroom

Eltherington has a large showroom at our manufacturing site in Hull, East Yorkshire, showcasing all of our architectural solutions. To arrange a visit, please call us on 01482 320336.

Design assistance

Our team can assist you in all aspects of regulatory compliance covering fire safety and ventilation.

Along with our standard range of column casings we can manufacture to your exact designs. We offer a full installer support programme.

Our commitment

Eltherington is at the forefront of innovation and performance in the rainscreen cladding sector. This gives customers confidence in our products, allowing them to realise their vision of creating buildings where people want to live and work.



Eltherington facade systems have been independently tested and accredited to the specific requirements of CWCT.

The Centre for Window and Cladding Technology (CWCT) is the leading provider of information in the area of building envelopes and glazing. The CWCT establishes industry standards and provides guidance to its members.



Full NBS specifications are available for all Eltherington rainscreen cladding solutions. We have an experienced technical team that can assist you in putting together designs and detailed specifications.



Eltherington offers RIBA-assessed, high-quality CPD seminars at your office or regional centres around the UK. Please contact our customer services department for more information.

Other solutions available from Eltherington:



Rainscreen cladding



Roofline



Internal cladding



Modular / off-site



Specialist fabrications



eltherington
architectural solutions
Innovation | Performance | Facades



Eltherington Aluminium Ltd, Dansom Lane South, Hull, East Yorkshire, HU8 7LA
T: 01482 320336 F: 01482 329956 E: info@Eltherington.co.uk