



# Heritage SCHAT

## Installation and Maintenance Instructions

**THESE INSTRUCTIONS MUST BE READ FULLY BEFORE COMMENCING INSTALLATION.**

CONTENTS	AC
	PAGE NO.
Electrical Data	2
Dimensional Data	3
Installation Instructions	4
General	4
Installation	4
Start Up	4
Fan Maintenance	4
Guarantee	4
Wiring Diagrams	5

# Heritage SCHAT

## Electrical Data



Product Code	Supply	FLC Amps	Output kW	Speed r/min	Wiring Diagram No.
SCHT315/6-3	380V to 415V/3Ph/50Hz	1.30	0.37	960	152-600
SCHT315/4-3	380V to 415V/3Ph/50Hz	1.20	0.37	1440	152-600
SCHT350/6-3	380V to 415V/3Ph/50Hz	1.30	0.37	960	152-600
SCHT350/4-3	380V to 415V/3Ph/50Hz	1.50	0.55	1440	152-600
SCHT400/6-3	380V to 415V/3Ph/50Hz	1.30	0.37	960	152-600
SCHT400/4-3	380V to 415V/3Ph/50Hz	1.50	0.55	1440	152-600
SCHT450/6-3	380V to 415V/3Ph/50Hz	1.30	0.37	960	152-600
SCHT450/4-3	380V to 415V/3Ph/50Hz	1.50	0.55	1440	152-600
SCHT500/6-3	380V to 415V/3Ph/50Hz	1.30	0.37	960	152-600
SCHT500/4-3	380V to 415V/3Ph/50Hz	2.90	1.10	1440	152-600
SCHT560/6-3	380V to 415V/3Ph/50Hz	1.80	0.55	960	152-600
SCHT560/4-3	380V to 415V/3Ph/50Hz	4.80	2.20	1440	152-600
SCHT630/6-3	380V to 415V/3Ph/50Hz	3.40	1.10	960	152-600
SCHT630/4-3	380V to 415V/3Ph/50Hz	8.03	4.00	1440	152-601

Elta Fans Limited has a policy of continuous product development and improvement and therefore reserves the right to supply products which may differ from those illustrated and described in this publication. Confirmation of dimensions and data will be supplied on request.

# Heritage SCHAT

## Dimensional Data

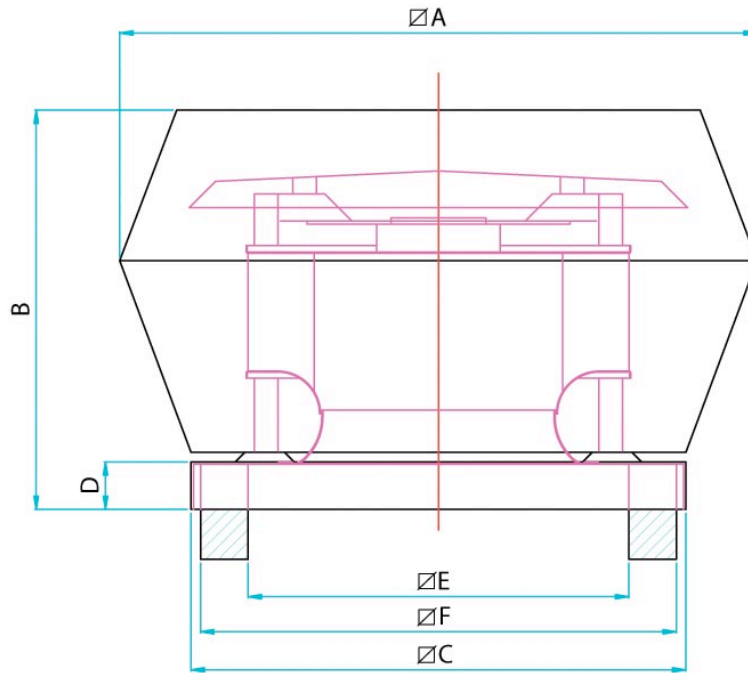

Product Code	A	B	C	D	E	F	Weight Kg	
							4-Pole	6-Pole
<b>SCHT315</b>	520	310	430	50	310	410	16	16
<b>SCHT350</b>	665	420	520	50	400	500	26	26
<b>SCHT400</b>	665	420	520	50	400	500	26	26
<b>SCHT450</b>	900	540	740	60	620	720	49	49
<b>SCHT500</b>	900	540	740	60	620	720	57	51
<b>SCHT560</b>	900	540	740	60	620	720	65	56
<b>SCHT630</b>	1160	665	830	60	710	810	97	78

Elta Fans Limited has a policy of continuous product development and improvement and therefore reserves the right to supply products which may differ from those illustrated and described in this publication. Confirmation of dimensions and data will be supplied on request.

### 1.0 GENERAL

- 1.1 It is important these Installation and Maintenance Instructions are fully adhered to.
- 1.2 Full details of the unit supplied are shown on the product nameplate. If in doubt about any detail contact Elta Fans Ltd or its agents for clarification.
- 1.3 All electrical installation must be carried out by suitably qualified and competent personnel in accordance with all current statutory requirements.
- 1.4 These instructions cover only the Elta Fans Ltd product and do not include the supply or installation of any safety equipment that may be required e.g. adequate guarding or protection from rotating parts and proper electrical isolation.
- 1.5 Any declarations made by Elta Fans Ltd about product installation and safety, are dependant on the fan equipment being used within installations which themselves meet the requirements of the relevant Standards and Directives of your region.
- 1.6 The fan is designed for use in an ambient temperature of -20°C up to a maximum of +50°C (refer to the relevant table) and up to 95% relative humidity. The fan is not suitable for corrosive or explosive atmospheres.
- 1.7 The installer should provide easy access to the fan to facilitate future maintenance.
- 1.8 The installer should ensure the fan is adequately supported.
- 1.9 This product is not intended for use by persons (including children) with reduced physical, sensory or mental capabilities, or lack of experience and knowledge, unless they have been given supervision or instruction concerning use of the product by a person responsible for their safety.  
Children should be supervised to ensure that they do not play with the product.
- 1.10 At end-of-life, the unit must be disposed of in an environmentally friendly manner by suitably qualified and competent personnel in accordance with the requirements of applicable Standards and Directives.

### 2.0 INSTALLATION

**WARNING – The fan must be isolated from the power supply during installation and maintenance. The fan must be earthed in accordance with the local regulations.**

- 2.1 Upon receipt, the fan equipment should be visually inspected to check for any damage. Ensure that the impeller is free to rotate.
- 2.2 If there are any queries concerning the fan equipment, Elta Fans Ltd should be contacted prior to the installation.
- 2.3 The fan must be securely mounted in the desired position to suit the application. The fan can be mounted on flat or inclined roofs with a maximum pitch angle of 15°.
- 2.4 Position the assembled roof fan unit onto the curb and secure to the timber sill with M10 coach bolts (not supplied by Elta Fans), ensuring that fibre washers are positioned under each bolt head. It is advisable to drill pilot holes prior to fitting the bolts to prevent splitting the timber curb.
- 2.5 Check the details on the motor rating plate to ensure that the correct power supply (voltage, frequency and phase) is available.  
An incorrect power supply will lead to permanent damage to the fan motor.
- 2.6 Refer to the appropriate wiring diagram. Ensure that all earth connections are made.
- 2.7 Means for electrical disconnection must be incorporated in the wiring installation in accordance with the relevant wiring and electrical regulations.
- 2.8 Precaution must be taken to locate the exhaust discharge terminal so as to avoid the backflow of gases into the room from the open flue of gas or other fuel burning appliances.

### 3.0 START-UP

- 3.1 Before power is supplied to the unit, check that the wiring is correct as per the fan connection diagram.
- 3.2 At initial start-up, check that impeller rotation and airflow direction is correct.
- 3.3 Check that the motor amperage draw does not exceed the nameplate rating.

### 4.0 FAN MAINTENANCE

- 4.1 Inspection of the fan at least once every 12 months is recommended to ensure that the motor, fan blades, and supporting guards, are clean. Any build up of dust and deposits on the blades or guards should be removed using a non-abrasive cleaner.
- 4.2 All fastenings should be checked for tightness. In addition, all rotating items should be checked.
- 4.3 Bearings are of the 'sealed for life' type and will not need a detailed inspection.

### 5.0 GUARANTEE

Elta Fans Ltd will, free of charge, within a period of 1 year from the date of dispatch from their works, repair or at its option replace any goods which are proved to have defects as a result of defective materials or workmanship. The goods MUST be returned to Elta Fans Ltd carriage paid for examination.

**WARNING – Fuses/circuit breakers are used to provide short circuit protection only. A starter panel with overload protection should be used to protect the motor.**

**Once the motor cools down the fan may start unexpectedly.**

**Only a suitably qualified and competent person may carry out maintenance after the electrical supply has been isolated.**

Elta Fans Limited has a policy of continuous product development and improvement and therefore reserves the right to supply products which may differ from those illustrated and described in this publication. Confirmation of dimensions and data will be supplied on request.

# Heritage SCHAT

## Wiring Diagrams

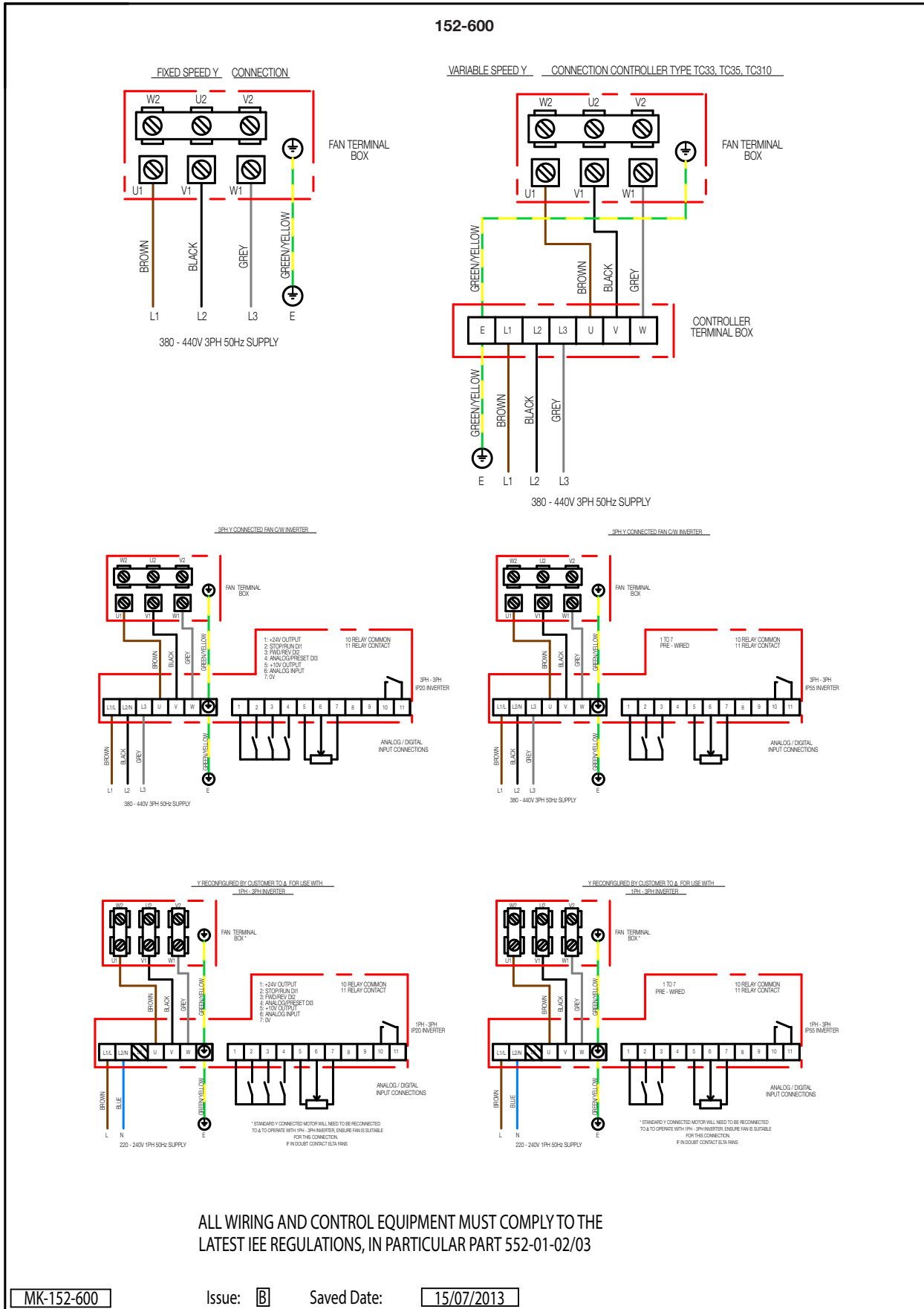

Elta Fans Limited has a policy of continuous product development and improvement and therefore reserves the right to supply products which may differ from those illustrated and described in this publication. Confirmation of dimensions and data will be supplied on request.

# Heritage SCHAT

## Wiring Diagrams



152-601

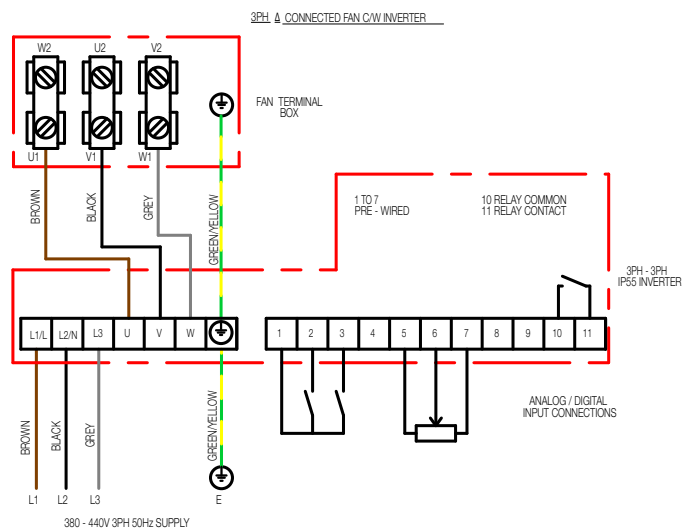
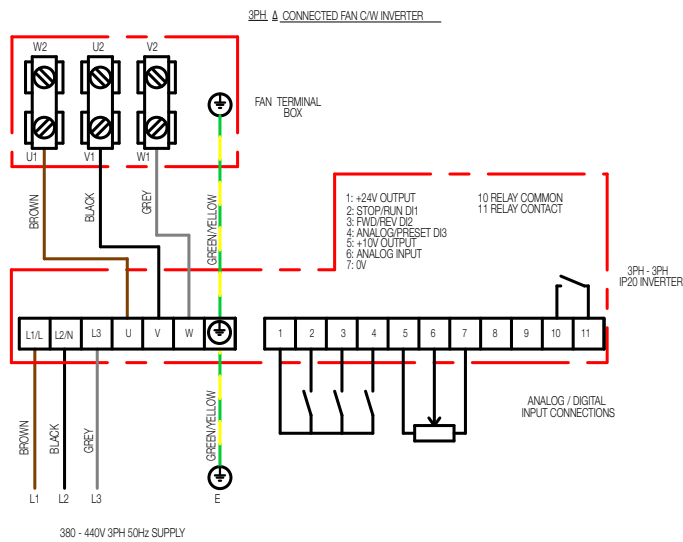
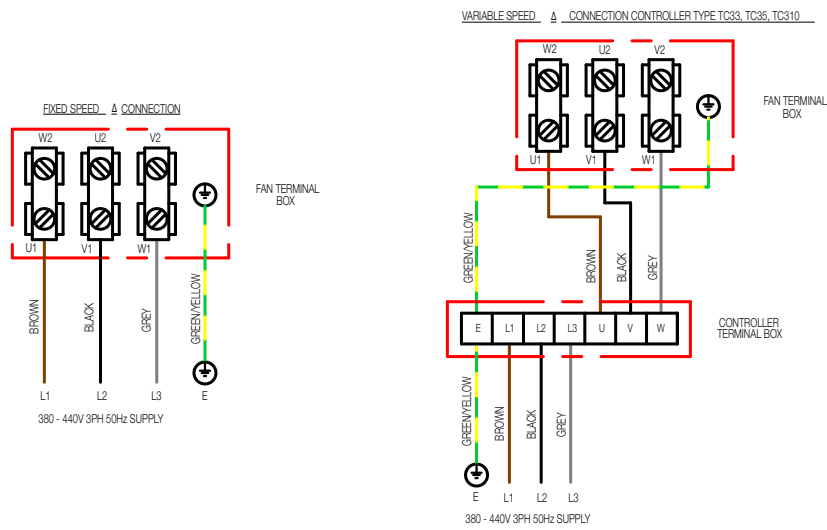

ALL WIRING AND CONTROL EQUIPMENT MUST COMPLY TO THE LATEST IEE REGULATIONS, IN PARTICULAR PART 552-01-02/03

MK-152-601

Issue:

Saved Date:

15/07/2013

Elta Fans Limited has a policy of continuous product development and improvement and therefore reserves the right to supply products which may differ from those illustrated and described in this publication. Confirmation of dimensions and data will be supplied on request.



## EC DECLARATION OF CONFORMITY/INCORPORATION

Herewith we declare that the air movement equipment below, on the basis of its design and construction in the form brought onto the market is in accordance within the relevant health and safety requirements of the EC Directive for use of machinery.

EC Declaration of Conformity	EC Declaration of Incorporation
	<p>In accordance with the Machinery Directive 2006/42/EC</p>
<p>Designation of Equipment:</p> <p>Raptor, Compact, Powerplus, Revolution, Miniflow, Multiflow, Viper, Jetflow, Jetstream, Hideaway, Singleflow, Quietflow, Twinflow, Powerduct, Qube, Slim-Qube, Skyflow, Heritage, Biflow, Zoo Fan, Ceiling Fan, SmokeVent, Pedestal, Window/Wall, Ezifit</p> <p>Type:</p> <p>SPA, SDA, SCP, SCPA, SCD, SCPP, SPP, SLC, SAMF, SMB, SMC, SMT, SCC, HIT, SJS, SH, SSD, SQS, SQSDCV, STD, SQT, SQTDCV, SPD, SQU, SQU-HT, SSQU, SSR, SSF, SSMF, SMF, SSSDR, SSSDRDCV, STDR, STDRDCV, SGE, SCH, SCHAT, SSFV, SSRV, SSC, SB, SDF, HCF, HPFA, HWFA, SRC, SAX, SRE, SEIE, SEWE</p> <p>Low Voltage Directive 2006/95/EC Electromagnetic Compatibility (EMC) Directive 2004/108/EC Energy-Related Products (ErP) Directive 2009/125/EC</p> <p>Herewith declare that the air movement equipment below, on the basis of its design and construction as partly completed machines brought onto the market is in compliance within relevant health and safety requirements of the EC Directives stated above. In the event that alterations are made to the machinery without prior consent with the manufacturer, this declaration becomes invalid.</p>	<p>Designation of Equipment:</p> <p>Raptor, Compact, Powerplus, Revolution, Miniflow, Multiflow, Viper, Jetflow, Jetstream, Hideaway, Singleflow, Quietflow, Twinflow, Powerduct, Qube, Slim-Qube, Skyflow, Heritage, Biflow, Zoo Fan, Ceiling Fan, SmokeVent, Window/Wall, Ezifit</p> <p>Type:</p> <p>SPA, SDA, SCP, SCPA, SCD, SCPP, SPP, SLC, SAMF, SMB, SMC, SMT, SCC, HIT, SJS, SH, SSD, SQS, SQSDCV, STD, SQT, SQTDCV, SPD, SQU, SQU-HT, SSQU, SSR, SSF, SSMF, SMF, SSSDR, SSSDRDCV, STDR, STDRDCV, SGE, SCH, SCHAT, SSFV, SSRV, SSC, SB, SDF, HCF, SEIE, SEWE</p> <p>The design of the partly completed machines listed below complies with the Essential Health and Safety Requirements (EHSRs) of ANNEX I, sections 1.1.2, 1.1.5, 1.4.1, 1.5.1 in EC Machinery Directive 2006/42/EC</p> <p>The partly completed machines comply with the requirements of :- Low Voltage Directive 2006/95/EC, Electromagnetic Compatibility (EMC) Directive 2004/108/EC, Energy-Related Products (ErP) Directive 2009/125/EC</p> <p>The machinery is incomplete and must not be put into service until such time as the machinery which is partly complete is to be incorporated and has been assessed and declared in conformity with the provisions of the Machinery Directive 2006/42/EC.</p> <p>We undertake to transmit, upon reasoned request by appropriate national authorities, relevant information on the partly completed machinery identified above.</p>
<p>Manufacturer: Elta Fans Limited 17 Barnes Wallis Road Segensworth East Industrial Estate Fareham, Hampshire PO15 5ST, UK</p>	
<p>Date / Signature of Manufacturer:</p>	<p>Date: 20th May 2013</p>
<p style="text-align: center;"> </p> <p>Name / Position of Signatory: Mr. Robert Rees Q.A.Manager Elta Fans Ltd,</p>	



#### BUILDING SERVICES

**Tel:** +44 (0) 1384 275800  
**Fax:** +44 (0) 1384 275810  
**e-mail:** bs@eltofans.co.uk

46 Third Avenue  
Pensnett Trading Estate  
Kingswinford, West Midlands  
DY6 7US, United Kingdom

#### APPLIED TECHNOLOGY

**Tel:** +44 (0) 1489 566500  
**Fax:** +44 (0) 1489 566555  
**e-mail:** at@eltofans.co.uk

17 Barnes Wallis Road  
Segensworth East Industrial Estate  
Fareham, Hampshire  
PO15 5ST, United Kingdom

#### EXPORT

**Tel:** +44 (0) 1489 566500  
**Fax:** +44 (0) 1489 566555  
**e-mail:** export@eltofans.co.uk

17 Barnes Wallis Road  
Segensworth East Industrial Estate  
Fareham, Hampshire  
PO15 5ST, United Kingdom

[www.eltofans.com](http://www.eltofans.com)



BS EN ISO 9001:2008  
FM 556465



A member of  
HEVAC ASSOCIATION



PATRONS

A member of

**ELTA**  
GROUP LIMITED