

ETA Approved through-bolts

High performance anchoring into
cracked and non-cracked concrete



Option 1 and Option 7

The Quality Connection www.ejot.co.uk



Next generation through-bolts

Option 1 and Option 7

High performance products with EJOT® technical support

The EJOT range of high performance through-bolts offers designers, engineers and installers the complete range of ETA approved products, manufactured to provide a safe and reliable solution for regular heavy-duty scenarios through to the most demanding applications in cracked and non-cracked concrete.

The second generation BA-Plus range has been engineered to provide vastly upgraded torque controlled efficiency, with Option 1 approval for the most critical cracked and non-cracked concrete scenarios - in the most demanding environmental situations.

In addition, the new BA-C NC zinc plated through-bolt comes with Option 7 approval for non-cracked concrete. That means safety and a cost-effective investment for virtually all indoor applications

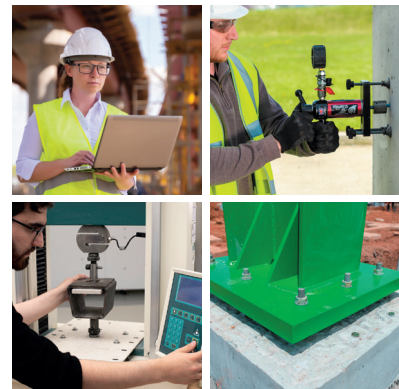

Call 01977 687040
info@ejot.co.uk



EJOT UK is a manufacturing member of the CFA.
www.the-cfa.co.uk

ZAG -National Building and Civil Engineering Institute, Slovenia
ETA-18/0219
EAD 330232-00-0601



Seismic Resistance

ZAG -National Building & Civil Engineering Institute, Slovenia / Fobatec GmbH, Dortmund, Germany EOTA TR 045
BA-V Plus / BA-E Plus anchor size M8
C1 anchor size M10, M12, M16: C



Fire Resistance

ZAG -National Building and Civil Engineering Institute, Slovenia / MFPA Institute for Materials Research and Testing, Leipzig, Germany
ETA-18/0219
EOTA TR 020 / EN 1992-4



Contents



OVERVIEW

| | |
|-------------------------|--------|
| Materials and Approvals | Page 6 |
| Size Range | Page 7 |



SPECIFICATION

| | |
|----------------------|--------|
| Calculation software | Page 8 |
| Site testing support | Page 8 |



TECHNICAL DATA

| | |
|------------------------------------|---------|
| Static & quasi-static loads | Page 9 |
| Seismic resistance (Option 1 only) | Page 11 |
| Fire resistance (Option 1 only) | Page 12 |
| Material | Page 14 |
| Installation | Page 15 |



ACCESSORIES

| | |
|------------------------------------|---------|
| Drill Bits, Blow Pumps and Brushes | Page 18 |
| Setting Tool BA | Page 18 |

Solutions-driven through-bolts for performance-driven designers.

EJOT has upgraded its BA through-bolt range to provide designers with a fully comprehensive choice of **ETA Option One** high performance anchors, ready and available for the most demanding applications in cracked and non-cracked concrete.

**NEW
ADVANCED
BA-PLUS
RANGE**

BA-Plus through-bolt range

Option One approval for cracked / non-cracked concrete

- TECHNICAL range for total performance
- M8 and M10: Offer installation into thinner concrete
- M10 and M12: Provide dual anchorage depths
- NEW Coloured depth-setting added to thread
- NEW Anchor length ID code added to head
- FEWER TURNS to reach specified installation torque
- CORROSION RESISTANT for harsh environments
- INCLUDES safety-critical, fire and seismic options



ETA-18/0219
Option One
Cracked / Non-cracked concrete

Call 01977 687040
www.ejot.co.uk/throughbolts

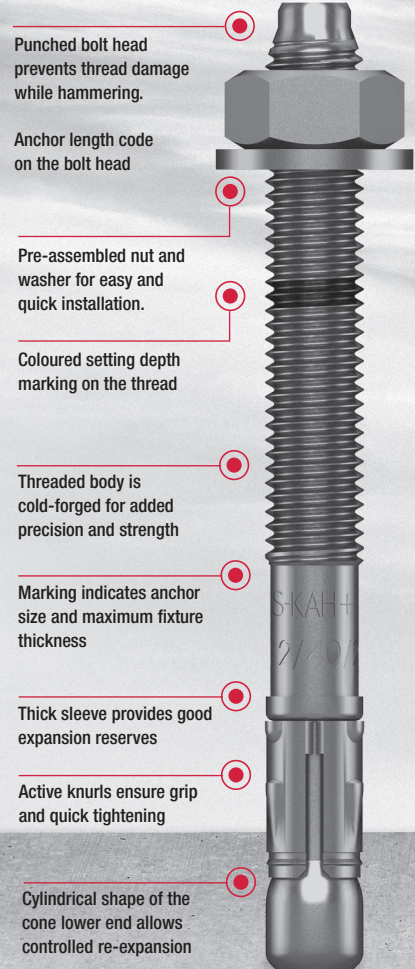

BA-E PLUS
A4 Stainless Steel

**NEW TO
THE EJOT
RANGE:
BA-C NC**

BA-C NC through-bolt
Option Seven for
non-cracked concrete

Not every 'everyday' anchor comes with its own ETA - but this one does! That's because the new BA-C NC through-bolt is engineered to the same exacting standards as EJOT's technical BA-Plus range, and manufactured in zinc plated carbon steel to provide a high performance solution for indoor applications into non-cracked concrete.

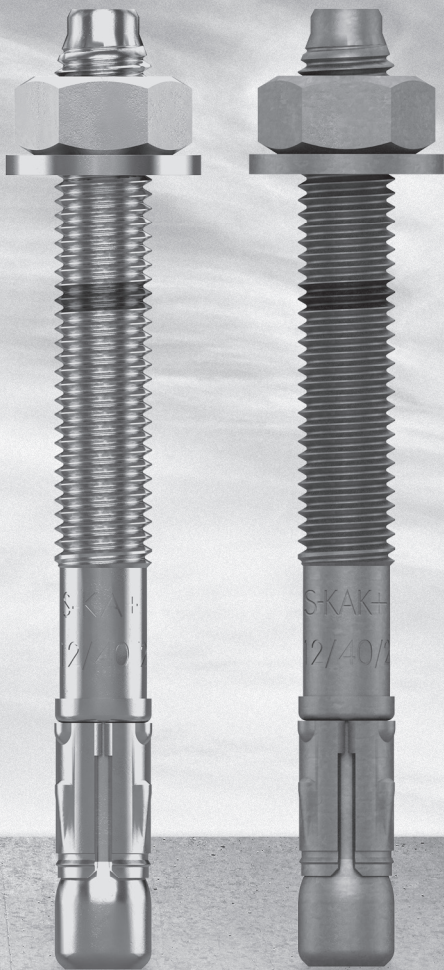

BA-V PLUS
Zinc Plated
Carbon Steel

BA-F PLUS
Carbon Steel
Hot Dip Galv.

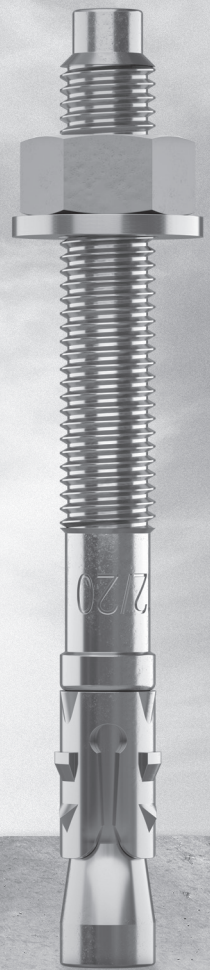

BA-C NC
Zinc Plated
Carbon Steel



ETA-20/0286
Option Seven
Non-cracked concrete

Through-bolts range at a glance



**BA-V Plus
Option 1**













**BA-F Plus
Option 1**



**BA-E Plus
Option 1**



**BA-C NC
Option 7**

| | | | | |
|-----------------------|--|--|---|--|
| Material | Carbon steel Zinc electroplated | Carbon steel Hot dip galvanized | Stainless steel A4 | Carbon steel Zinc electroplated |
| Applications | Dry indoor conditions, indoor with temporary condensation | Humid indoor use, outdoor inland rural areas only in not safety relevant applications | For indoor, outdoor, industrial use and maritime climate. | Dry internal conditions |
| Base materials | Cracked concrete Non-cracked concrete | Cracked concrete Non-cracked concrete | Cracked concrete Non-cracked concrete | Non-Cracked concrete \geq C20/25 ,Option 7* |
| Thread size* | M8, M10, M12, M16 | M8, M10, M12, M16 | M8, M10, M12, M16 | M8, M10, M12, M16 |
| Tools | Setting tool BA | Setting tool BA | Setting tool BA | Setting tool BA |
| Technical data |  F120  C1/C2 |  F120 |  F120  C1/C2  | |
| Approvals |  ETA-18/0219 |  ETA-18/0219 |  ETA-18/0219 |  ETA-20/0286 |

Note: Diameter M6 for multiple use for non-structural applications in concrete available on demand.

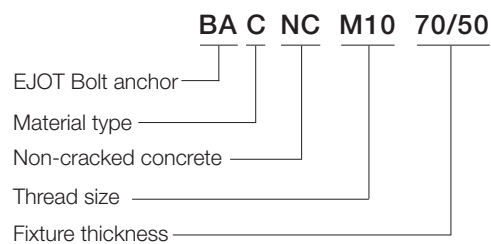
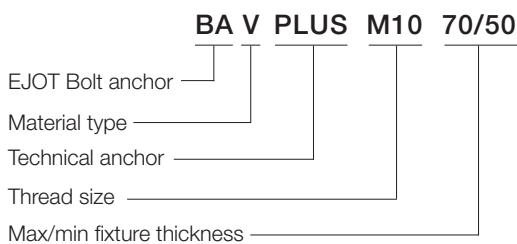

Through-bolt size range guide

Typical order descriptions

BA-V Plus (Option 1)

Through Bolt BA-V Plus 8/10

Through Bolt BA-E Plus 12/40/20

Through Bolt BA-F Plus 12/85/65

BA-C NC (Option 7)

BA-C 10/10 NC Through Bolt



| Thread size | Type | t _{fix} | Length | BA-V Plus | BA-F Plus | BA-E Plus | BA-C-NC |
|-------------|------------|------------------|--------|-----------|-----------|-----------|---------|
| M8 | M8x50 (5)* | 5 | 50 | - | - | - | • |
| | M8/10 | 10 | 75 | • | • | • | • |
| | M8/30 | 30 | 95 | • | • | • | • |
| | M8/50 | 50 | 115 | • | • | • | • |
| | M8/85 | 85 | 150 | • | • | • | - |
| M10 | M10/10/- | 10 | 72 | • | • | • | - |
| | M10/10 | 10 | 85 | - | - | - | • |
| | M10/30/10 | 30/10 | 92 | • | • | • | - |
| | M10/20 | 20 | 95 | - | - | - | • |
| | M10/40/20 | 40/20 | 102 | • | • | • | - |
| | M10/30 | 30 | 105 | - | - | - | • |
| | M10/50/30 | 50/30 | 112 | • | • | • | - |
| | M10/50 | 50 | 125 | - | - | - | • |
| | M10/70/50 | 70/50 | 132 | • | • | • | - |
| M10/100/80 | 100/80 | 162 | • | • | • | - | |
| M12 | M12/10/- | 10 | 88 | • | • | • | - |
| | M12/25/5 | 25/5 | 103 | • | • | • | - |
| | M12/10 | 10 | 110 | - | - | - | • |
| | M12/40/20 | 40/20 | 118 | • | • | • | - |
| | M12/20 | 20 | 120 | - | - | - | • |
| | M12/30 | 30 | 130 | - | - | - | • |
| | M12/70/50 | 70/50 | 148 | • | • | • | - |
| | M12/50 | 50 | 150 | - | - | - | • |
| | M12/85/65 | 85/65 | 163 | • | • | • | - |
| M12/100/80 | 100/80 | 178 | • | • | • | - | |
| M16 | M16/5 | 5 | 123 | • | • | • | - |
| | M16/10 | 10 | 135 | - | - | - | • |
| | M16/20 | 20 | 138 | • | • | • | - |
| | M16/20 | 20 | 145 | - | - | - | • |
| | M16/50 | 50 | 168 | • | • | • | - |
| | M16/50 | 50 | 175 | - | - | - | • |
| M16/60 | 60 | 178 | • | • | • | - | |

• BA-F Plus: Please request supply times.

* No ETA

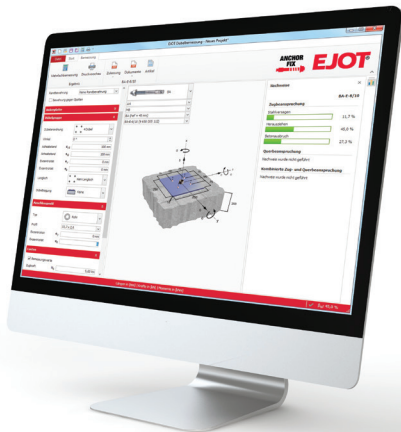

Calculation software

EJOT's Anchor-fix dimensioning software is a goto tool to assist designers with pre-planning through to static requirements for critical building projects.

The program was developed for structural engineers, specifiers, engineers and technicians to calculate the load-carrying capacity of anchor bolts in concrete substrates - allowing data to be archived for reference.

In addition, also offers:

- Access to approval documents and product data sheets
- Language options for international use.
- Automatic updates

EJOT Anchor Fix can be downloaded here:

www.ejot.com/software-anchorfix



On site testing and support

When specifying outside of any standard technical parameters our technical team will recommend an on-site test report, carried out by a qualified EJOT engineer.

Whilst we can be sure of the technical performance of our products, no-one can second guess the integrity of substrates. Where high loadings into critical structural areas create potential risk, we want our customers to have absolute peace of mind and confidence in the match between fixing and substrate - and the correct installation process

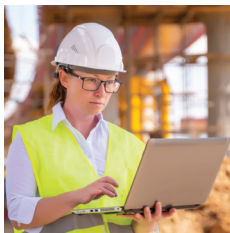

Important note relating to all data

- Load figures include the partial safety factors as per approvals and a partial safety factor on the action of $\gamma_F = 1.4$. Load figures apply for a rebar spacing $s \geq 15$
- If spacings or edge distances become smaller than the characteristic figures ($s_{cr,N} / c_{cr,N}$) a calculation as per EOTA TR 055 needs to be carried out. For more details, see ETAs.
- Concrete is considered non-cracked when the value of tension within the concrete is $\sigma_L + \sigma_R \leq 0$. In the absence of detailed verification $\sigma_R = 3 \text{ N/mm}^2$ can be assumed (σ_L equals the tension within the concrete as a result of external loads, forces on anchor included; σ_R equals the tension coming from shrinkage or creep of the concrete, as well as displacements of supports or temperature variations).
- Shear load figures apply for an anchor without influence of a concrete edge. For shear loads close to an edge ($c \leq 10 \times h_{ef}$), concrete edge failure has to be checked as per EOTA TR 055.

Static and quasi-static loads

Characteristic resistances

| Anchor size | | | OPTION 1 | | | | | OPTION 7 | | | | | | |
|------------------------------------|-----------------------|----|----------|-------|-------|-------|---------|----------|-----|------|------|------|------|----|
| | | | M8 | M10 | M12 | M16 | M8 x 50 | M8 | M10 | M12 | M16 | | | |
| Effective anchorage depth h_{ef} | | | mm | 48 | 40 | 60 | 50 | 70 | 85 | 23 | 43 | 50 | 70 | 85 |
| Non-cracked concrete | | | | | | | | | | | | | | |
| Tensile N_{Rk} | BA-V Plus / BA-F Plus | kN | 11.0 | 12.0 | 19.0 | 17.4 | 25.0 | 36.0 | | | | | | |
| | BA-E Plus / BA-E Plus | kN | 11.0 | 12.0 | 19.0 | 17.4 | 25.0 | 36.0 | | | | | | |
| | BA-C NC (Option 7) | kN | - | - | - | - | - | - | 4.3 | 11.0 | 13.0 | 17.0 | 22.0 | |
| Shear V_{Rk} | BA-V Plus / BA-F Plus | kN | 12.6* | 20.4* | 20.4* | 30.0* | 30.0* | 54.1* | | | | | | |
| | BA-E Plus / BA-E Plus | kN | 15.8* | 20.4* | 20.4* | 34.4* | 34.4* | 68.6* | | | | | | |
| | BA-C NC (Option 7) | kN | - | - | - | - | - | - | 5.4 | 7.0* | 13.0 | 20.0 | 34.0 | |
| Cracked concrete | | | | | | | | | | | | | | |
| Tensile N_{Rk} | BA-V Plus / BA-F Plus | kN | 8.5 | 8.7 | 12.2 | 12.2 | 16.0 | 24.0 | | | | | | |
| | BA-E Plus / BA-E Plus | kN | 8.5 | 8.7 | 12.2 | 12.2 | 16.0 | 24.0 | | | | | | |
| Shear V_{Rk} | BA-V Plus / BA-F Plus | kN | 12.6* | 20.4* | 20.4* | 34.6 | 30.0* | 54.1* | | | | | | |
| | BA-E Plus / BA-E Plus | kN | 15.8* | 20.4* | 20.4* | 34.6 | 34.4* | 73.1 | | | | | | |
| *Failure mode = steel | | | | | | | | | | | | | | |

Design resistances

| Anchor size | | | OPTION 1 | | | | | OPTION 7 | | | | | | |
|------------------------------------|-----------------------|----|----------|-------|-------|-------|---------|----------|-----|-------|------|-------|-------|----|
| | | | M8 | M10 | M12 | M16 | M8 x 50 | M8 | M10 | M12 | M16 | | | |
| Effective anchorage depth h_{ef} | | | mm | 48 | 40 | 60 | 50 | 70 | 85 | 23 | 43 | 50 | 70 | 85 |
| Non-cracked concrete | | | | | | | | | | | | | | |
| Tensile N_{Rd} | BA-V Plus / BA-F Plus | kN | 7.3 | 8.0 | 12.7 | 11.6 | 16.7 | 24.0 | - | - | - | - | - | - |
| | BA-E Plus / BA-E Plus | kN | 7.3 | 8.0 | 12.7 | 11.6 | 16.7 | 24.0 | - | - | - | - | - | - |
| | BA-C NC (Option 7) | kN | - | - | - | - | - | - | 2.4 | 6.1 | 8.7 | 9.4 | 14.7 | |
| Shear V_{Rd} | BA-V Plus / BA-F Plus | kN | 10.1* | 16.3* | 16.3* | 24.0* | 24.0* | 43.3* | - | - | - | - | - | - |
| | BA-E Plus / BA-E Plus | kN | 12.6* | 16.3* | 16.3* | 27.5* | 27.5* | 54.9* | - | - | - | - | - | - |
| | BA-C NC (Option 7) | kN | - | - | - | - | - | - | 3.6 | 5.18* | 8.68 | 15.82 | 22.68 | |
| Cracked concrete | | | | | | | | | | | | | | |
| Tensile N_{Rd} | BA-V Plus / BA-F Plus | kN | 5.7 | 5.8 | 8.0 | 8.1 | 10.7 | 16.0 | - | - | - | - | - | - |
| | BA-E Plus / BA-E Plus | kN | 5.7 | 5.8 | 8.0 | 8.1 | 10.7 | 16.0 | - | - | - | - | - | - |
| Shear V_{Rd} | BA-V Plus / BA-F Plus | kN | 10.1* | 16.3* | 16.3* | 23.1 | 24.0* | 43.3* | - | - | - | - | - | - |
| | BA-E Plus / BA-E Plus | kN | 12.6* | 16.3* | 16.3* | 23.1 | 24.0* | 48.7 | - | - | - | - | - | - |
| *Failure mode = steel | | | | | | | | | | | | | | |

The data of these tables is based on:

Concrete C20/25, $f_{ck,cube} = 25 \text{ N/mm}^2$.

Installation has been done correctly (see page 17).

No influence of edge distances and spacings.

Accordance with minimum base material thickness (see page 16).

Static and quasi-static loads

Recommended loads

| Anchor size | | | OPTION 1 | | | | | OPTION 7 | | | | | |
|------------------------------------|-----------------------|----|----------|-------|-------|-------|---------|----------|-----|------|-----|------|------|
| | | | M8 | M10 | M12 | M16 | M8 x 50 | M8 | M10 | M12 | M16 | | |
| Effective anchorage depth h_{ef} | | mm | 48 | 40 | 60 | 50 | 70 | 85 | 23 | 43 | 50 | 70 | 85 |
| Non-cracked concrete | | | | | | | | | | | | | |
| Tensile N_{Rk} | BA-V Plus / BA-F Plus | kN | 5.2 | 5.7 | 9.0 | 8.3 | 11.9 | 17.1 | - | - | - | - | - |
| | BA-E Plus / BA-E Plus | kN | 5.2 | 5.7 | 9.0 | 8.3 | 11.9 | 17.1 | - | - | - | - | - |
| | BA-C NC (Option 7) | kN | - | - | - | - | - | - | 1.7 | 4.4 | 6.2 | 6.7 | 10.5 |
| Shear V_{Rk} | BA-V Plus / BA-F Plus | kN | 7.2* | 11.7* | 11.7* | 17.1* | 17.1* | 30.9* | - | - | - | - | - |
| | BA-E Plus / BA-E Plus | kN | 9.0* | 11.7* | 11.7* | 19.7* | 19.7* | 39.2* | - | - | - | - | - |
| | BA-C NC (Option 7) | kN | - | - | - | - | - | - | 2.6 | 3.7* | 6.2 | 11.3 | 16.2 |
| Cracked concrete | | | | | | | | | | | | | |
| Tensile N_{Rk} | BA-V Plus / BA-F Plus | kN | 4.0 | 4.1 | 5.7 | 5.8 | 7.6 | 11.4 | - | - | - | - | - |
| | BA-E Plus / BA-E Plus | kN | 4.0 | 4.1 | 5.7 | 5.8 | 7.6 | 11.4 | - | - | - | - | - |
| Shear V_{Rk} | BA-V Plus / BA-F Plus | kN | 7.2* | 11.7* | 11.7* | 16.5 | 17.1* | 30.9* | - | - | - | - | - |
| | BA-E Plus / BA-E Plus | kN | 9.0* | 11.7* | 11.7* | 16.5 | 19.7* | 34.8 | - | - | - | - | - |
| *Failure mode = steel | | | | | | | | | | | | | |

The data of these tables is based on:

Concrete C20/25, $f_{ck,cube} = 25 \text{ N/mm}^2$.

Installation has been done correctly (see page 17).

No influence of edge distances and spacings.

Accordance with minimum base material thickness (see page 16).



Seismic resistance (Option 1 only - BA-Plus)

Design acc. EOTA TR 045: Performance category C1/C2

Characteristic resistances

| Anchor size | | | OPTION 1 | | | |
|------------------------------------|-----------|----|----------|----------|----------|----------|
| | | | M8 (C1) | M10 (C2) | M12 (C2) | M16 (C2) |
| Effective anchorage depth h_{ef} | mm | | 48 | 60 | 70 | 85 |
| Cracked Concrete | | | | | | |
| Tensile $N_{Rk, se}$ | BA-V Plus | kN | 8.5 | 2.7 | 2.8 | 10.2 |
| | BA-E Plus | kN | 8.4 | 3.2 | 3.3 | 11.1 |
| Shear $V_{Rk, se}$ | BA-V Plus | kN | 4.1* | 4.3* | 6.9* | 15.4* |
| | BA-E Plus | kN | 4.0* | 4.7* | 7.2* | 15.4* |

Design resistance

| Anchor size | | | OPTION 1 | | | |
|------------------------------------|-----------|----|----------|----------|----------|----------|
| | | | M8 (C1) | M10 (C2) | M12 (C2) | M16 (C2) |
| Effective anchorage depth h_{ef} | mm | | 48 | 60 | 70 | 85 |
| Cracked Concrete | | | | | | |
| Tensile $N_{Rd, se}$ | BA-V Plus | kN | 5.7 | 1.8 | 1.9 | 6.8 |
| | BA-E Plus | kN | 5.6 | 2.1 | 2.2 | 7.4 |
| Shear $V_{Rd, se}$ | BA-V Plus | kN | 3.2* | 3.4* | 5.5* | 12.3* |
| | BA-E Plus | kN | 3.2* | 3.8* | 5.8* | 12.3* |

Recommended loads

| Anchor size | | | OPTION 1 | | | |
|------------------------------------|-----------|----|----------|----------|----------|----------|
| | | | M8 (C1) | M10 (C2) | M12 (C2) | M16 (C2) |
| Effective anchorage depth h_{ef} | mm | | 48 | 60 | 70 | 85 |
| Cracked Concrete | | | | | | |
| Tensile $N_{Rec, se}$ | BA-V Plus | kN | 4.0 | 1.3 | 1.3 | 4.9 |
| | BA-E Plus | kN | 4.0 | 1.5 | 1.6 | 5.3 |
| Shear $V_{Rec, se}$ | BA-V Plus | kN | 2.3* | 2.4* | 3.9* | 8.8* |
| | BA-E Plus | kN | 2.3* | 2.7* | 4.1* | 8.8* |

α_{seis} and α_{gap} included as per EOTA TR 045. The values don't consider any filling of the annular gap between the anchor and the fixture

* Failure mode = steel

The data of these tables is based on:

Concrete C20/25, $f_{ck, cube} = 25 \text{ N/mm}^2$.

Installation has been done correctly (see page 17).

No influence of edge distances and spacings.

Accordance with minimum base material thickness (see page 16).

Fire resistance (Option 1 only - BA-Plus)



Characteristic resistances

| Anchor size | | | OPTION 1 | | | | | |
|------------------------------------|-----------------------|----|----------|------|------|------|-------|-------|
| | | | M8 | M10 | | M12 | M16 | |
| Effective anchorage depth h_{ef} | mm | | 48 | 40 | 60 | 50 | 70 | 85 |
| R30 | | | | | | | | |
| Tensile $N_{Rk,fi}$ | BA-V Plus / BA-F Plus | kN | 1.31 | 1.82 | 2.09 | 3.05 | 3.05 | 5.69 |
| | BA-E Plus / BA-E Plus | kN | 2.13 | 1.82 | 3.00 | 3.18 | 4.00 | 6.00 |
| Shear $V_{Rk,fi}$ | BA-V Plus / BA-F Plus | kN | 1.31 | 1.82 | 2.09 | 3.05 | 3.05 | 5.69 |
| | BA-E Plus / BA-E Plus | kN | 2.87 | 1.82 | 6.66 | 3.18 | 10.25 | 19.09 |
| R60 | | | | | | | | |
| Tensile $N_{Rk,fi}$ | BA-V Plus / BA-F Plus | kN | 1.05 | 1.66 | 1.66 | 2.40 | 2.40 | 4.47 |
| | BA-E Plus / BA-E Plus | kN | 2.13 | 1.82 | 3.00 | 3.18 | 4.00 | 6.00 |
| Shear $V_{Rk,fi}$ | BA-V Plus / BA-F Plus | kN | 1.05 | 1.66 | 1.66 | 2.40 | 2.40 | 4.47 |
| | BA-E Plus / BA-E Plus | kN | 2.70 | 1.82 | 4.59 | 3.18 | 7.07 | 13.16 |
| R90 | | | | | | | | |
| Tensile $N_{Rk,fi}$ | BA-V Plus / BA-F Plus | kN | 0.80 | 1.24 | 1.24 | 1.74 | 1.74 | 3.25 |
| | BA-E Plus / BA-E Plus | kN | 1.48 | 1.82 | 2.52 | 3.18 | 3.88 | 6.00 |
| Shear $V_{Rk,fi}$ | BA-V Plus / BA-F Plus | kN | 0.80 | 1.24 | 1.24 | 1.74 | 1.74 | 3.25 |
| | BA-E Plus / BA-E Plus | kN | 1.48 | 1.82 | 2.52 | 3.18 | 3.88 | 7.23 |
| R120 | | | | | | | | |
| Tensile $N_{Rk,fi}$ | BA-V Plus / BA-F Plus | kN | 0.67 | 1.02 | 1.02 | 1.41 | 1.41 | 2.64 |
| | BA-E Plus / BA-E Plus | kN | 0.87 | 1.46 | 1.48 | 2.29 | 2.29 | 4.26 |
| Shear $V_{Rk,fi}$ | BA-V Plus / BA-F Plus | kN | 0.67 | 1.02 | 1.02 | 1.41 | 1.41 | 2.64 |
| | BA-E Plus / BA-E Plus | kN | 0.87 | 1.46 | 1.48 | 2.29 | 2.29 | 4.26 |
| *Failure mode = steel | | | | | | | | |

The data of these tables is based on:

Concrete C20/25, $f_{ck,cube} = 25 \text{ N/mm}^2$.

Installation has been done correctly (see page 17).

No influence of edge distances and spacings.

Accordance with minimum base material thickness (see page 16).

Fire resistance (Option 1 only - BA-Plus)



Recommended loads

| Anchor size | | | OPTION 1 | | | | | | |
|------------------------------------|-----------------------|----|----------|------|------|------|------|-------|-------|
| | | | M8 | M10 | | M12 | M16 | | |
| Effective anchorage depth h_{ef} | | mm | 48 | 40 | 60 | 50 | 70 | 85 | |
| R30 | | | | | | | | | |
| Tensile $N_{Rk,fi}$ | BA-V Plus / BA-F Plus | | kN | 1.31 | 1.82 | 2.09 | 3.05 | 3.05 | 5.69 |
| | BA-E Plus / BA-E Plus | | kN | 2.13 | 1.82 | 3.00 | 3.18 | 4.00 | 6.00 |
| Shear $V_{Rk,fi}$ | BA-V Plus / BA-F Plus | | kN | 1.31 | 1.82 | 2.09 | 3.05 | 3.05 | 5.69 |
| | BA-E Plus / BA-E Plus | | kN | 2.87 | 1.82 | 6.66 | 3.18 | 10.25 | 19.09 |
| R60 | | | | | | | | | |
| Tensile $N_{Rk,fi}$ | BA-V Plus / BA-F Plus | | kN | 1.05 | 1.66 | 1.66 | 2.40 | 2.40 | 4.47 |
| | BA-E Plus / BA-E Plus | | kN | 2.13 | 1.82 | 3.00 | 3.18 | 4.00 | 6.00 |
| Shear $V_{Rk,fi}$ | BA-V Plus / BA-F Plus | | kN | 1.05 | 1.66 | 1.66 | 2.40 | 2.40 | 4.47 |
| | BA-E Plus / BA-E Plus | | kN | 2.70 | 1.82 | 4.59 | 3.18 | 7.07 | 13.16 |
| R90 | | | | | | | | | |
| Tensile $N_{Rk,fi}$ | BA-V Plus / BA-F Plus | | kN | 0.80 | 1.24 | 1.24 | 1.74 | 1.74 | 3.25 |
| | BA-E Plus / BA-E Plus | | kN | 1.48 | 1.82 | 2.52 | 3.18 | 3.88 | 6.00 |
| Shear $V_{Rk,fi}$ | BA-V Plus / BA-F Plus | | kN | 0.80 | 1.24 | 1.24 | 1.74 | 1.74 | 3.25 |
| | BA-E Plus / BA-E Plus | | kN | 1.48 | 1.82 | 2.52 | 3.18 | 3.88 | 7.23 |
| R120 | | | | | | | | | |
| Tensile $N_{Rk,fi}$ | BA-V Plus / BA-F Plus | | kN | 0.67 | 1.02 | 1.02 | 1.41 | 1.41 | 2.64 |
| | BA-E Plus / BA-E Plus | | kN | 0.87 | 1.46 | 1.48 | 2.29 | 2.29 | 4.26 |
| Shear $V_{Rk,fi}$ | BA-V Plus / BA-F Plus | | kN | 0.67 | 1.02 | 1.02 | 1.41 | 1.41 | 2.64 |
| | BA-E Plus / BA-E Plus | | kN | 0.87 | 1.46 | 1.48 | 2.29 | 2.29 | 4.26 |
| *Failure mode = steel | | | | | | | | | |

The data of these tables is based on:

In the absence of other national regulations the partial safety factor or resistance under fire exposure $\gamma_{M,fi} = 1.0$ is recommended.

Concrete C20/25, $f_{ck,cube} = 25 \text{ N/mm}^2$.

Installation has been done correctly (see page 17).

No influence of edge distances and spacings.

Accordance with minimum base material thickness (see page 16).

Material and dimensions

BA-Plus Anchor dimensions (Option 1)

| Anchor size | | | M8 | M10 | M12 | M16 |
|---------------|------------------|----|--------|--------|--------|---------|
| Total length | L | mm | 62-420 | 62-420 | 78-420 | 118-420 |
| Sleeve length | L _s | mm | 14.8 | 17.9 | 19.1 | 26.0 |
| Bolt body | d _{nom} | mm | 8 | 10 | 12 | 16 |

BA-C NC Anchor dimensions (Option 7)

| Anchor size | | | M8 | M10 | M12 | M16 |
|---------------|------------------|----|--------|--------|------|------|
| Total length | L | mm | 50-135 | 85-215 | 110- | 135- |
| Sleeve length | L _s | mm | 14.4 | 16.5 | 19.0 | 23.0 |
| Bolt body | d _{nom} | mm | 8 | 10 | 12 | 16 |

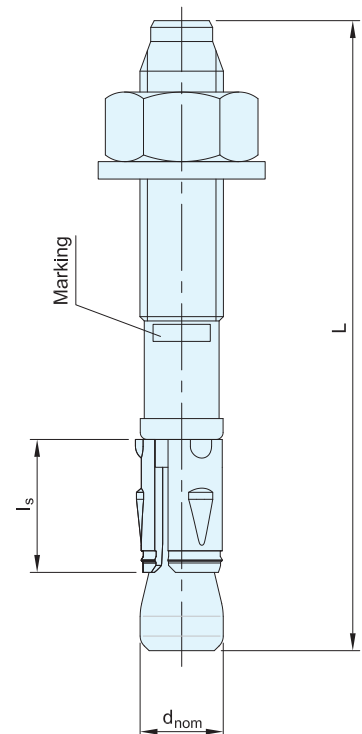

Mechanical properties

| Specifications | | | | OPTION 1 | | | | OPTION 7 | | | |
|--------------------------------|--------------------------------|-----------------------|-------------------|----------|------|------|-------|----------|------|------|-------|
| | | | | M8 | M10 | M12 | M16 | M8 | M10 | M12 | M16 |
| Nominal tensile strength | f _{uk, thread} | BA-V Plus / BA-F Plus | N/mm ² | 700 | 680 | 660 | 660 | - | - | - | - |
| | | BA-E Plus / BA-E Plus | N/mm ² | 670 | 680 | 660 | 660 | - | - | - | - |
| | | BA-C NC (Option 7) | N/mm ² | - | - | - | - | ≥550 | ≥670 | ≥630 | ≥600 |
| Char. bending resistance | M ⁰ _{Rk,s} | BA-V Plus / BA-F Plus | N/mm | 26.3 | 51 | 90 | 219.8 | - | - | - | - |
| | | BA-E Plus / BA-E Plus | N/mm | 25.1 | 51 | 90 | 214.8 | - | - | - | - |
| | | BA-C NC (Option 7) | N/mm | - | - | - | - | 12.0 | 25.6 | 45.1 | 104.4 |
| Design bending resistance | M _{Rd,s} | BA-V Plus / BA-F Plus | kN | 21.0 | 40.8 | 72.0 | 175.8 | - | - | - | - |
| | | BA-E Plus / BA-E Plus | kN | 20.1 | 40.8 | 72.0 | 171.8 | - | - | - | - |
| | | BA-C NC (Option 7) | kN | - | - | - | - | 10.0 | 17.1 | 35.8 | 69.6 |
| Recommended bending resistance | M _{Rec} | BA-V Plus / BA-F Plus | kN | 15.0 | 29.1 | 51.4 | 125.6 | - | - | - | - |
| | | BA-E Plus / BA-E Plus | kN | 14.3 | 29.1 | 51.4 | 122.7 | - | - | - | - |
| | | BA-C NC (Option 7) | kN | - | - | - | - | 64 | 12.2 | 25.6 | 49.7 |

Installation instructions

Installation data

| Specifications | | | | OPTION 1 | | | | OPTION 7 | | | | |
|---|-----------------------|------------|----|----------|-----|-----|-----|----------|-----|-----|-----|-----|
| | | | | M8 | M10 | M12 | M16 | M8 | M10 | M12 | M16 | |
| Drill hole diameter | BA-Plus | d_0 | mm | 8 | 10 | 12 | 16 | - | - | - | - | |
| | BA-C NC (Option 7) | | mm | - | - | - | - | 8 | 10 | 12 | 16 | |
| Depth of drilled hole to deepest point | BA-Plus | $h_1 \geq$ | mm | 60 | 55 | 75 | 70 | 90 | 110 | - | - | - |
| | BA-C NC (Option 7) | | mm | - | - | - | - | - | 63 | 69 | 92 | 109 |
| Effective anchorage depth | BA-Plus | h_{ef} | mm | 48 | 40 | 50 | 70 | 85 | - | - | - | - |
| | BA-C NC (Option 7) | | mm | - | - | - | - | - | 43 | 50 | 70 | 85 |
| Nominal anchorage depth | BA-Plus | h_{nom} | mm | 53 | 48 | 68 | 61 | 81 | 97 | - | - | - |
| Diameter of clearance hole in the fixture | BA-Plus | $d_f \geq$ | mm | 9 | 12 | 14 | 18 | - | - | - | - | |
| | BA-C NC (Option 7) | | mm | - | - | - | - | 9 | 12 | 14 | 18 | |
| Width across flats | BA-Plus | SW | mm | 13 | 17 | 19 | 24 | - | - | - | - | |
| | BA-C NC (Option 7) | | mm | - | - | - | - | 13 | 17 | 19 | 24 | |
| Required torque | BA-V Plus / BA-F Plus | T_{inst} | Nm | 15 | 30 | 60 | 110 | - | - | - | - | |
| | BA-E Plus / BA-E Plus | | Nm | 20 | 45 | 60 | 110 | - | - | - | - | |
| | BA-C NC (Option 7) | | Nm | - | - | - | - | 15 | 30 | 50 | 90 | |

Installation methods

Through installation

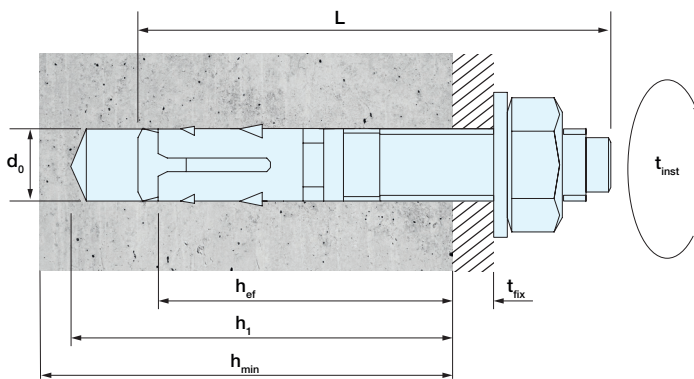

Distance installation

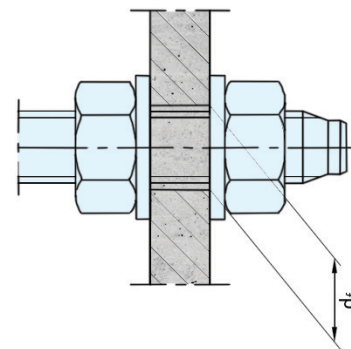

Product and installed conditions

- L - through-bolt length
- d_0 - nominal drill bit diameter
- h_1 - depth of drill holes to deepest point
- h_{min} - minimum thickness of concrete member
- h_{ef} - effective anchorage depth
- t_{fix} - thickness of fixture

Installation parameters

BA-Plus Range (Option 1)

| Cracked and non-cracked concrete | | | Minimum thickness of concrete member, spacing and edge distance | | | | | |
|---|---------------|----|---|-----|-----|-----|-----|-----|
| | | | M8 | M10 | | M12 | | M16 |
| Effective anchorage depth | h_{ef} | mm | 48 | 40 | 60 | 50 | 70 | 85 |
| Minimum thickness of base material | h_{min} | mm | 100 | 100 | 120 | 100 | 140 | 170 |
| | $h_{min-red}$ | mm | 80 | - | 100 | - | - | - |
| Minimum spacing for h_{min} | s_{min} | mm | 35 | 50 | 40 | 55 | 60 | 65 |
| | $c \geq$ | mm | 50 | 95 | 60 | 110 | 70 | 95 |
| Minimum edge distance for h_{min} | c_{min} | mm | 40 | 50 | 50 | 60 | 55 | 65 |
| | $s \geq$ | mm | 55 | 190 | 100 | 215 | 110 | 150 |
| Minimum spacing for $h_{min-red}$ | s_{min} | mm | 35 | - | 40 | - | - | - |
| | $c \geq$ | mm | 55 | - | 100 | - | - | - |
| Minimum edge distance for h_{min} | c_{min} | mm | 40 | - | 60 | - | - | - |
| | $S \geq$ | mm | 60 | - | 90 | - | - | - |
| Critical spacing for splitting failure and concrete cone failure (in case characteristic loading affects) | $s_{cr,sp}$ | mm | 192 | 160 | 240 | 200 | 280 | 340 |
| | $s_{cr,N}$ | mm | 144 | 120 | 180 | 150 | 210 | 254 |
| Critical edge distance for splitting failure and concrete cone failure (in case characteristic loading affects) | $c_{cr,sp}$ | mm | 96 | 80 | 120 | 100 | 140 | 170 |
| | $c_{cr,N}$ | mm | 72 | 60 | 90 | 75 | 105 | 127 |

BA-C NC (Option 7)

| Non-cracked concrete (Option 7) | | | Minimum thickness of concrete member, spacing and edge distance | | | |
|-------------------------------------|-----------|----|---|-----|-----|-----|
| | | | M8 | M10 | M12 | M16 |
| Effective anchorage depth | h_{ef} | mm | 43 | 50 | 70 | 85 |
| Minimum thickness of base material | h_{min} | mm | 100 | 120 | 150 | 160 |
| Minimum spacing for h_{min} | s_{min} | mm | 50 | 100 | 120 | 140 |
| Minimum edge distance for h_{min} | c_{min} | mm | 50 | 90 | 100 | 125 |

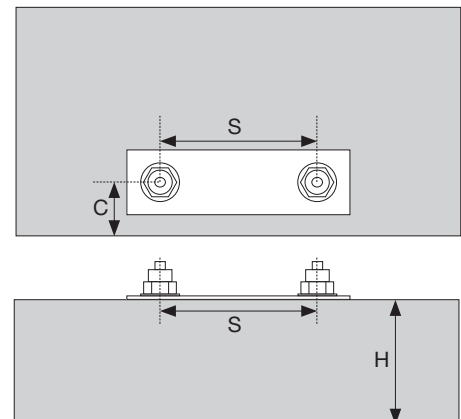
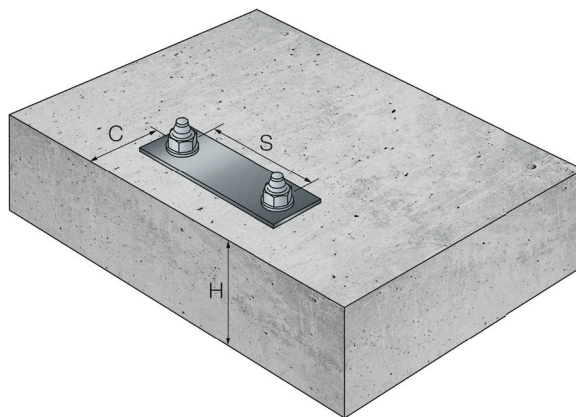

Through-bolt setting instructions

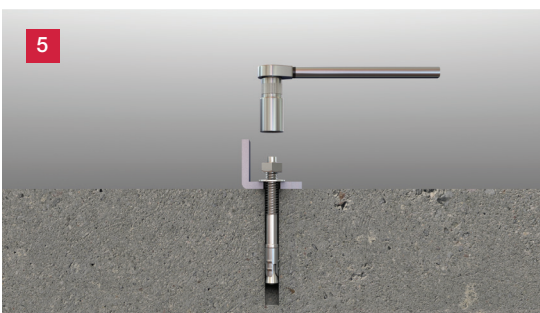
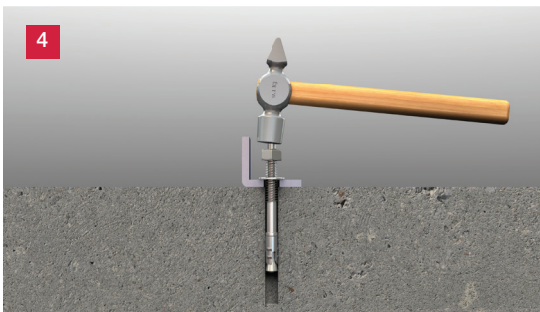
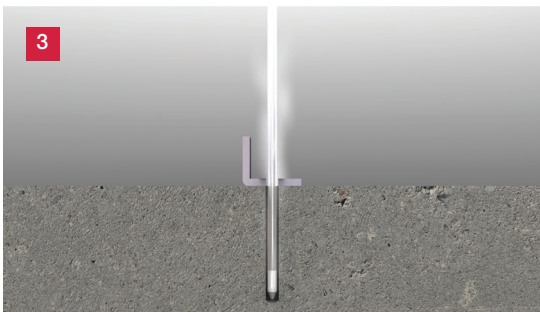
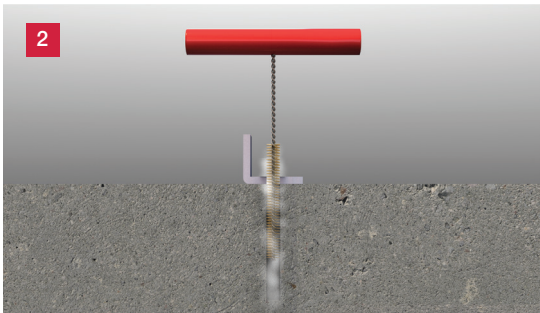
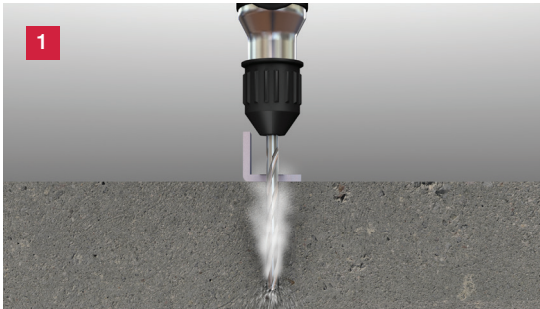

Successful specification of critical fixings and product life performance relies upon correct installation and setting.

This five step best practice guide illustrates the essential stages that should be followed to achieve safe and correct performance.

Details of EJOT's specialist Setting Tool BA can be found with our accessories overview on the following page.

Installation

1. Drill a hole according to the product data.
2. Clean the hole using a metal brush.
3. Remove dust using a blow-out pump.
Note: Repeat steps 2 & 3 at least three times.
4. Install anchor with a hammer or a setting tool.
5. Tighten the anchor to the specified installation torque.

As a guide to show user benefits and ease of installation of EJOT through-bolt products, you can view our Anchor Bolt installation animation on the EJOT UK YouTube Channel.

youtube.com/EJOTUK



Scan me

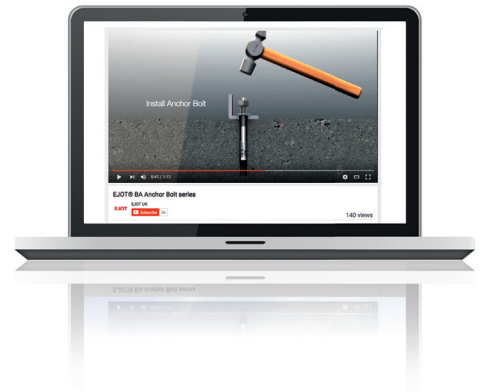

Installation tools and accessories



With the vast amount of research and development invested into the design and manufacture of all EJOT fastening systems, installation tools are of equal importance in achieving optimised performance and correct function of product.

These tools and accessories have been designed specifically for use with EJOT anchoring products to deliver correct installation features and to maximise efficiency for the installer.



SDS drill bits



Vortex-SDS dust reduction

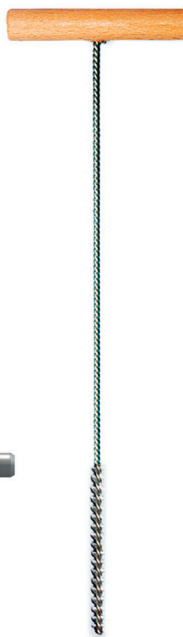

Metal brushes



EJOT blow-out pump



Setting tool BA

Setting tool BA

Hammering tool to make through-bolt installation quicker and smoother

- Original EJOT through-bolts setting tool with specially designed head that does not damage the top of the anchor and keeps the head from slipping
- Besides ensuring the most efficient and safe through-bolt installation in general, the setting tool also significantly saves time and energy in repetitive installation
- Compatible with all SDS+ drills



Product description:

Setting Tool BA for Through-bolt M6 - M10
 Setting Tool BA for Through-bolt M2 - M16

For further information on specific installation accessories visit EJOT online or talk to a member of our technical sales team.
 Call 01977 687040 info@ejot.co.uk

Buy online in the EJOT webshop

EJOT UK's webshop means you can view and buy our fixing products and systems online.

- Technical information at a click
- Fast – easy to register, easy to navigate
- Quick search by product or by application
- Automatically creates your purchase history - saves valuable time
- **Scan the code right and visit our online webshop**





EJOT U.K. Limited,
Hurricane Close,
Sherburn Enterprise Park,
Sherburn-in-Elmet,
Leeds LS25 6PB.
United Kingdom

Tel: 01977 68 70 40
Fax: 01977 68 70 41
Email: info@ejot.co.uk

www.ejot.co.uk



EJOT® The Quality Connection