



Easy Drain<sup>®</sup>  
by ess

## Trapezium Multi

Easy Drain Specials, for special bathroom designs. The Trapezium Multi linear shower drain is specially developed when drainage in a corner is required, with a diagonal tiled shower floor and a 5-sided shower variant. The unique ABS trap body can be shortened to any desired height and is supplied with three water seals. If required, another type of Multi trap body can be ordered separately.

### FEATURES

- Certified - EN 1253
- Grate - Height adjustable grate
- Siphon - Removable and easy to clean
- Supplied as - Complete set
- Trap body - Pivoted and height adjustable



#### Manufacturer

Easy Sanitary Solutions  
Nijverheidsstraat 60 | 7575 BK Oldenzaal | The Netherlands  
T. +31 (0)541 200 800 | F. +31 (0)541 200 899  
info@esspost.com | www.easydrain.com

#### Contact

Easy Sanitary Solutions  
Nijverheidsstraat 60 | 7575 BK Oldenzaal | The Netherlands  
T. +31 (0)541 200 800 | F. +31 (0)541 200 899  
sales@esspost.com | www.easydrain.com

## GENERAL

Serie	Specials
Name	Trapezium Multi
Model	Specials
Length (mm)	300, 700
Product type	Complete
Application	New construction
Certification	EN 1253, DIN 18534

## INSTALLATION

Substrate	Concrete / Sand Cement, Wooden floors, Lewis sheets
Floor finish	Tiles / Mosaic, Glass Mosaic, Thin tiles
Height adjustable feet	Included
Installation option	Floor
Outlet	Horizontal (Vertical outlet optional)
Connection (mm)	50 (Global) / 56 (UK)
Min. installation depth (mm) (built-in set)	59
Min. installation depth (mm) (incl. grate)	79

## DRAINAGE

Max. drainage capacity entrance (l/min)	38
Max. drainage capacity wall (l/min)	49
Max. drainage capacity (l/min)	49

## BUILT-IN SET

Pre-assembled sealing membrane (WPS)	Excluded
Siphon features	Cleanable, Pivotal & adjustable, Height adjustable
Water seal height (mm)	30 / 35 / 50
Outlet	Horizontal (Vertical outlet optional)
Material siphon	ABS

## DESIGN

Grate finish	Brushed stainless steel
Grate pattern	Fixt
Grate width (mm)	98
Grate tile insert (mm)	N.A.
Adjustable grate	Yes
Frame type	N.A.
TAF Frame material	N.A.
Design frame finish	N.A.
Frame width (mm)	N.A.
Wheelchair accessible	Yes
Extension set available	No



### Manufacturer

Easy Sanitary Solutions  
 Nijverheidsstraat 60 | 7575 BK Oldenzaal | The Netherlands  
 T. +31 (0)541 200 800 | F. +31 (0)541 200 899  
 info@esspost.com | www.easydrain.com

### Contact

Easy Sanitary Solutions  
 Nijverheidsstraat 60 | 7575 BK Oldenzaal | The Netherlands  
 T. +31 (0)541 200 800 | F. +31 (0)541 200 899  
 sales@esspost.com | www.easydrain.com

## ARTICLE CODE

300 mm	EDMTRAP300		
700 mm	EDMTRAP700		

## TECHNICAL DRAWINGS

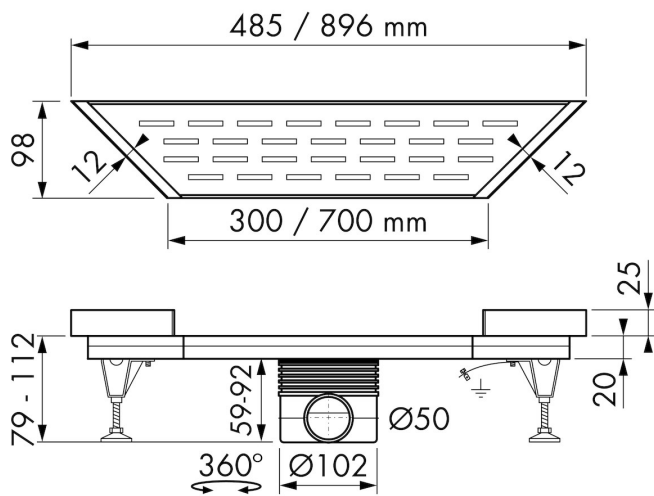

**Manufacturer**

Easy Sanitary Solutions  
 Nijverheidsstraat 60 | 7575 BK Oldenzaal | The Netherlands  
 T. +31 (0)541 200 800 | F. +31 (0)541 200 899  
 info@esspost.com | www.easydrain.com

**Contact**

Easy Sanitary Solutions  
 Nijverheidsstraat 60 | 7575 BK Oldenzaal | The Netherlands  
 T. +31 (0)541 200 800 | F. +31 (0)541 200 899  
 sales@esspost.com | www.easydrain.com