

Easy Drain[®]

by ess

Multi TAF

Easy Drain Multi TAF, the worlds most multifunctional linear shower drain, comes standard with height adjustable frame (TAF) and pre-assembled sealing membrane (WPS). This way, the grate adapts perfectly to you bathroom floor and ensures complete drainage of shower water. Multi TAF drain is delivered complete and comes with a reversible grate.

FEATURES

- Available lengths - 500 - 2000 mm
- Water Protection System - 10-year warranty
- Siphon - Easy to clean
- Certified - EN 1253
- Supplied as - Complete set



Manufacturer

Easy Sanitary Solutions
Nijverheidsstraat 60 | 7575 BK Oldenzaal | The Netherlands
T. +31 (0)541 200 800 | F. +31 (0)541 200 899
info@esspost.com | www.easydrain.com

Contact

Easy Sanitary Solutions
Nijverheidsstraat 60 | 7575 BK Oldenzaal | The Netherlands
T. +31 (0)541 200 800 | F. +31 (0)541 200 899
sales@esspost.com | www.easydrain.com

Page 1 / 3

GENERAL

Serie	Multi TAF
Name	Multi TAF
Model	Linear shower drain
Length (mm)	500, 600, 700, 800, 900, 1000, 1100, 1200, 1300, 1400, 1500, 1600, 1700, 1800, 1900, 2000
Product type	Complete
Application	New construction, Renovation
Certification	EN 1253, ETAG-022, DIN 18534

INSTALLATION

Substrate	Concrete / Sand Cement, Wooden floors, Lewis sheets
Floor finish	Tiles / Mosaic, Glass Mosaic, Thin tiles
Height adjustable feet	Included
Installation option	Floor
Outlet	Horizontal (Vertical outlet optional)
Connection (mm)	50 (Global) / 56 (UK)
Min. installation depth (mm) (built-in set)	79
Min. installation depth (mm) (incl. grate)	85

DRAINAGE

Max. drainage capacity entrance (l/min)	38
Max. drainage capacity wall (l/min)	N.A.
Max. drainage capacity (l/min)	38

BUILT-IN SET

Pre-assembled sealing membrane (WPS)	Included
Siphon features	Cleanable, Pivotal & adjustable, Height adjustable
Water seal height (mm)	30 / 35 / 50
Outlet	Horizontal (Vertical outlet optional)
Material siphon	ABS

DESIGN

Grate finish	Brushed stainless steel / Tile
Grate pattern	Zero / Closed
Grate width (mm)	95
Grate tile insert (mm)	12
Adjustable grate	No
Frame type	TAF (Tile Adjustable Frame)
TAF Frame material	Stainless steel (304)
Design frame finish	N.A.
Frame width (mm)	95
Wheelchair accessible	Yes
Extension set available	No



Manufacturer

Easy Sanitary Solutions
 Nijverheidsstraat 60 | 7575 BK Oldenzaal | The Netherlands
 T. +31 (0)541 200 800 | F. +31 (0)541 200 899
 info@esspost.com | www.easydrain.com

Contact

Easy Sanitary Solutions
 Nijverheidsstraat 60 | 7575 BK Oldenzaal | The Netherlands
 T. +31 (0)541 200 800 | F. +31 (0)541 200 899
 sales@esspost.com | www.easydrain.com

ARTICLE CODE

500 mm	EDMTAF500	1300 mm	EDMTAF1300
600 mm	EDMTAF600	1400 mm	EDMTAF1400
700 mm	EDMTAF700	1500 mm	EDMTAF1500
800 mm	EDMTAF800	1600 mm	EDMTAF1600
900 mm	EDMTAF900	1700 mm	EDMTAF1700
1000 mm	EDMTAF1000	1800 mm	EDMTAF1800
1100 mm	EDMTAF1100	1900 mm	EDMTAF1900
1200 mm	EDMTAF1200	2000 mm	EDMTAF2000

TECHNICAL DRAWINGS

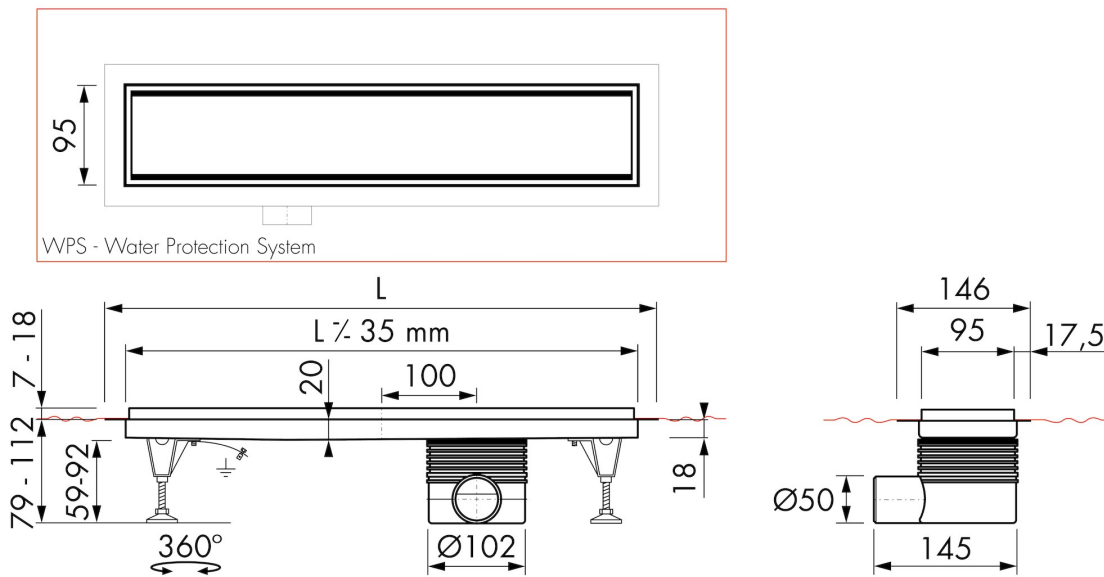

Manufacturer

Easy Sanitary Solutions
 Nijverheidsstraat 60 | 7575 BK Oldenzaal | The Netherlands
 T. +31 (0)541 200 800 | F. +31 (0)541 200 899
 info@esspost.com | www.easydrain.com

Contact

Easy Sanitary Solutions
 Nijverheidsstraat 60 | 7575 BK Oldenzaal | The Netherlands
 T. +31 (0)541 200 800 | F. +31 (0)541 200 899
 sales@esspost.com | www.easydrain.com