



Easy Drain[®]

by ess

Multi TAF Wall

Easy Drain Multi TAF Wall, the worlds most multifunctional linear shower drain, comes standard with height adjustable frame (TAF) and pre-assembled sealing membrane (WPS). This way, the grate adapts perfectly to you bathroom floor and ensures complete drainage of shower water. Multi TAF drain is delivered as a complete set and comes with a reversible grate.

FEATURES

- Available lengths - 500 - 2000 mm
- Water Protection System - 10-year warranty
- Siphon - Easy to clean
- Certified - EN 1253
- Supplied as - Complete set



Manufacturer

Easy Sanitary Solutions
Nijverheidsstraat 60 | 7575 BK Oldenzaal | The Netherlands
T. +31 (0)541 200 800 | F. +31 (0)541 200 899
info@esspost.com | www.easydrain.com

Contact

Easy Sanitary Solutions
Nijverheidsstraat 60 | 7575 BK Oldenzaal | The Netherlands
T. +31 (0)541 200 800 | F. +31 (0)541 200 899
sales@esspost.com | www.easydrain.com

Page 1 / 3

GENERAL

Serie	Multi TAF Wall
Name	Multi TAF Wall
Model	Linear shower drain
Length (mm)	500, 600, 700, 800, 900, 1000, 1100, 1200, 1300, 1400, 1500, 1600, 1700, 1800, 1900, 2000
Product type	Complete
Application	New construction, Renovation
Certification	EN 1253, ETAG-022, DIN 18534

INSTALLATION

Substrate	Concrete / Sand Cement, Wooden floors, Lewis sheets
Floor finish	Tiles / Mosaic, Glass Mosaic, Thin tiles
Height adjustable feet	Included
Installation option	Wall
Outlet	Horizontal (Vertical outlet optional)
Connection (mm)	50 (Global) / 56 (UK)
Min. installation depth (mm) (built-in set)	79
Min. installation depth (mm) (incl. grate)	85

DRAINAGE

Max. drainage capacity entrance (l/min)	49
Max. drainage capacity wall (l/min)	N.A.
Max. drainage capacity (l/min)	49

BUILT-IN SET

Pre-assembled sealing membrane (WPS)	Included
Siphon features	Cleanable, Pivotal & adjustable, Height adjustable
Water seal height (mm)	30 / 35 / 50
Outlet	Horizontal (Vertical outlet optional)
Material siphon	ABS

DESIGN

Grate finish	Brushed stainless steel / Tile
Grate pattern	Zero / Closed
Grate width (mm)	95
Grate tile insert (mm)	12
Adjustable grate	No
Frame type	TAF (Tile Adjustable Frame)
TAF Frame material	Stainless steel (304)
Design frame finish	N.A.
Frame width (mm)	113
Wheelchair accessible	Yes
Extension set available	Yes



Manufacturer

Easy Sanitary Solutions
 Nijverheidsstraat 60 | 7575 BK Oldenzaal | The Netherlands
 T. +31 (0)541 200 800 | F. +31 (0)541 200 899
 info@esspost.com | www.easydrain.com

Contact

Easy Sanitary Solutions
 Nijverheidsstraat 60 | 7575 BK Oldenzaal | The Netherlands
 T. +31 (0)541 200 800 | F. +31 (0)541 200 899
 sales@esspost.com | www.easydrain.com

ARTICLE CODE

500 mm	EDMTAFW500	1300 mm	EDMTAFW1300
600 mm	EDMTAFW600	1400 mm	EDMTAFW1400
700 mm	EDMTAFW700	1500 mm	EDMTAFW1500
800 mm	EDMTAFW800	1600 mm	EDMTAFW1600
900 mm	EDMTAFW900	1700 mm	EDMTAFW1700
1000 mm	EDMTAFW1000	1800 mm	EDMTAFW1800
1100 mm	EDMTAFW1100	1900 mm	EDMTAFW1900
1200 mm	EDMTAFW1200	2000 mm	EDMTAFW2000

TECHNICAL DRAWINGS

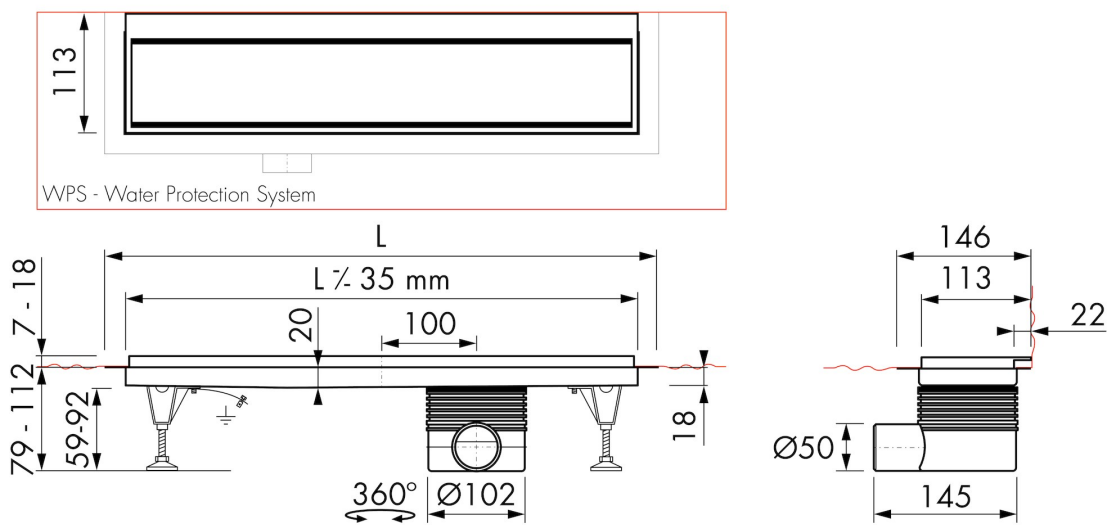

Manufacturer

Easy Sanitary Solutions
 Nijverheidsstraat 60 | 7575 BK Oldenzaal | The Netherlands
 T. +31 (0)541 200 800 | F. +31 (0)541 200 899
 info@esspost.com | www.easydrain.com

Contact

Easy Sanitary Solutions
 Nijverheidsstraat 60 | 7575 BK Oldenzaal | The Netherlands
 T. +31 (0)541 200 800 | F. +31 (0)541 200 899
 sales@esspost.com | www.easydrain.com