

EB2 Technical Data Sheet

The Easibathe shower seats have been designed to provide assistance and comfort to any shower area. They are all of high quality, functional, safe and stylish, designed to be mounted on to a solid or reinforced wall within a wet floor, shower enclosure or shower cubicle.



Code	EB2-BL / EB2-GR
Seat width	460mm
Seat depth	325mm
Min height	440mm
Max height	560mm
Distance from wall	460mm
Weight limit	35st (222kg)

- Manufactured from heavy duty anodised aluminium with a white powder coated finish
- Textured seating surface with drainage holes reduce water retention and assist cleaning
- Height adjustable legs for precision fitting & slip resistant rubber feet
- Range of seat sizes to accommodate standard and bariatric users
- Load rating of 35 stone (222kg)
- Quality tested to comply with BS:EN12182:1999 and MDA Alert MDA/2003/029
- Supplied with removable seat pad
- Available in blue or grey to aid the visually impaired



Easibathe[®]



Independence House, Federation Way, Lancaster Road, Dunston, Tyne & Wear, NE11 9JR

Freephone: 0800 321 7430, Tel: 0191 460 2777, Fax: 0191 460 2888

Email: info@easibathe.com Web: www.easibathe.com

EB2 Technical Data Sheet

Front View

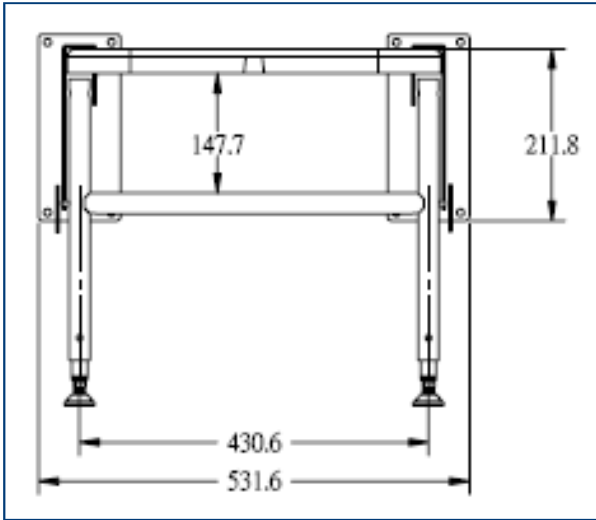

Side View

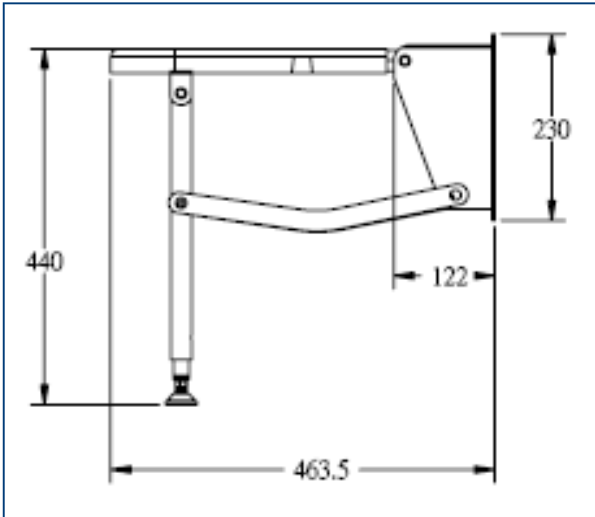

NB: All measurements shown are in millimetres. Drawing sizes are not to scale.

