



DUPLUS

# MODULAR ROOFLIGHT

Installation Instructions Including  
Maintenance Manual

Need help? Call us on 0116 2610 710



# MODULAR ROOFLIGHT OVERVIEW

Duplus fixed modular rooflights are glazed with two panes of 4mm toughened glass on rooflights where both the length and width is less than 1200mm and two panes of 6mm toughened glass thereafter. 28mm double glazed units incorporating the latest Low E coating, warm edge spacer bar and argon filled cavity achieving a centre pane U-value of 1.1 W/m<sup>2</sup>K.

Our rooflights are suitable (as defined in BS5516-2:2004) up to a maximum height of 13 metres above floor level.

For further clarification on any technical issues, please do not hesitate to contact Duplus.

**Need help? Call us on 0116 2610 710**



# CONTENTS

1.0	Product Inspection	Page 4
2.0	Installation Hardware	Page 4
3.0	Kerb Suitability Check	Page 4
4.0	Installation	Page 6
5.0	Standard Glass Specification	Page 12
6.0	Glass Information	Page 13
7.0	Glass Breakage	Page 14
8.0	General Cleaning & Maintenance	Page 14
9.0	Emergency Contact Information	Page 15
10.0	Drawing References SB001, SB005 & SBCD7&9	Page 16

Need help? Call us on 0116 2610 710



## 1.0 Product Inspection

- 1.1 Upon receipt of your product firstly carry out an inspection of the packaging, if there are any signs of impact damage this should be reported to Duplus Architectural Systems (DAS) with suitable photographs within 24hrs of delivery. If no damage is found carefully remove the packaging, including the perimeter snap in cover clips (which must be retained) and fully inspect the product, again reporting any damage within 24hrs of delivery.
- 1.2 Do not use a knife when removing packaging; this may result in damage to the product.
- 1.3 Do not remove the wooden support feet until you have the rooflight next to the rooflight opening.
- 1.4 Do not attempt to carry the rooflight with the perimeter snap in cover clips in place.

## 2.0 Standard Installation Hardware

- 2.1 Plastic Horse Shoe packers in varying thicknesses, 5mm, 3mm, 2mm & 1mm
- 2.2 50mm long stainless steel wood screws.

## 3.0 Kerb Suitability Check

- 3.0 A full inspection of the kerb should be undertaken before the installation begins. Please ensure there is sufficient unobstructed space around the immediate area, ensure all necessary safety systems are in place to enable safe working at height procedures. The kerbs should be surveyed to ensure dimensional accuracy please see accompanying drg SB001 for details.

### Please Note:

- 3.2 Water ponding is more likely to occur where our product has been fitted to a shallow sloping kerb or where the builders curb has no fall or slope. However, it is not a sign of any failure within our product. Water will pond where there is an insufficient fall to make it drain away naturally. Easy clean coatings can improve the situation as they tend to smooth out any surface imperfections of the glass.
- 3.3 Our fixed and opening rooflights are designed to accommodate a 10 degree fall where water is less likely to pond.

Cont'd

**Need help? Call us on 0116 2610 710**



Important note.

- 3.3 Kerb must be fully weather tight before installation, external finishes should lap up and on to the top of the kerb before seating the SB Skylight in position. The top of the kerb should be flat with no pronounced level changes particularly at the corners.
- 3.4 To ensure water does not pond on the SB Skylight it is vital the kerb is built in accordance with the parameters set on drg SB001. Please note the kerb should always be formed as a flat annulus at the same pitch as the SB skylight.

**Need help? Call us on 0116 2610 710**



## 4.0 Installation

### Duplus Continuous Rooflight Installation Guide

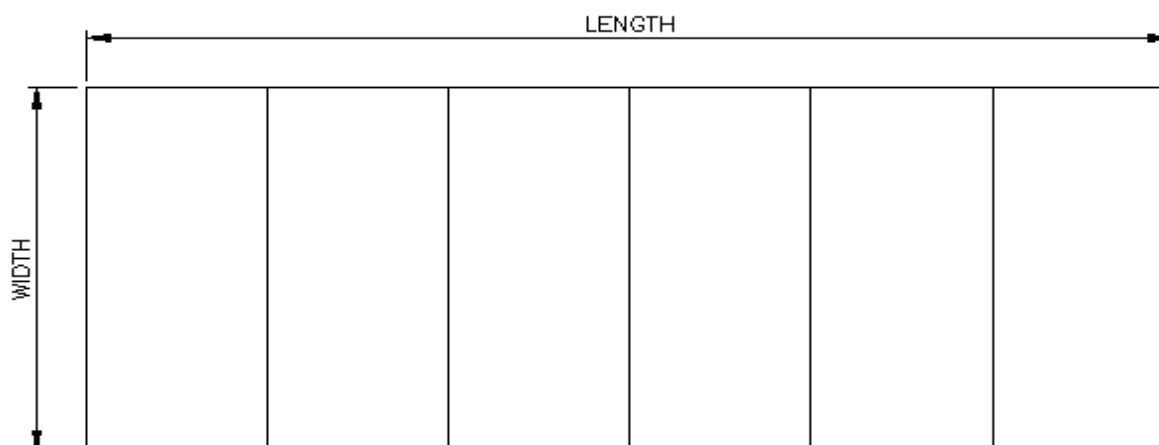

#### Step 1. Inspect The Builders Kerb

Inspect the builder's kerb.

There must be a fall between the top and the bottom of the rooflight. Duplus suggest a slope angle of 5 degrees which equates to a height of 87mm per 1000mm of width.

The opening must be square. Check this by measuring the distance between the external corners of the builder's kerb diagonally and compare both measurements. These should be within 10mm of each other.

Measure the external kerb width and length between their extremes and check that the dimensions are within +/- 20mm of those provided on the Duplus information details .

Ensure that there are no projections along the top of the kerb or on the outer vertical face of the kerb within 75mm from the top edge of the kerb.

If there are any areas of concern please check with Duplus (Tel 0116 2610 710) before starting to install.

#### Step 2. Check Along The Length of The Builders Kerb.

In the length, it is vital to fit to the top of a LEVEL builder's kerb.

Pull a string line tight across the top of the builder's kerb in the length (between the external edge and 75mm in from the external edge) and review the line for level. Ensure both kerbs in the length are checked. In the width, any kerb variations can be accommodated by placing packers internally under the end frame rooflight framework after its installation.

Cont'd

**Need help? Call us on 0116 2610 710**



### Step 3. Create A Level Kerb

It is important that the rooflight is fitted to a level kerb with no high points. Hence where the kerb and string line do not come into contact, using silicone, adhere packers to the kerb at 150mm intervals (between the external edge and 75mm in from the external edge) in order to build the kerb height to the level of the string line. Do not attempt to move onto step 4 until you are sure that the kerb or kerb with packers will provide a level base, along the kerb length, for the rooflight to sit onto.

### Step 4. Positioning The Rooflight - Width

As the rooflight is made up of a number of separate frames that are joined together in a straight line it is essential to determine if there is any bowing of the builder's kerb or roofing membrane applied to it before commencing installation. If the kerb bows out at a particular point further than the rest of the builder's kerb and gives a 'wide' point when looking on plan, it is this 'wide' point that will be the closest point between rooflight internal fixing face and the builder's kerb. Once started the rooflights position is extremely difficult and time consuming to move, so it is vital to consider any variation or bowing on plan of the kerb (only the top 75mm) to ensure that the builder's kerb extremes do not clash with the rooflight framework.

To determine this, pull a string line tight across the vertical face of the uppermost long length of the builder's kerb at positions between the top edge of the rooflight and 75mm down from that top edge.

Adjust the string line until it runs parallel with the face of the builder's kerb and with the line still in contact with the highest point on the face of the builder's kerb measure the gap between the string line and the kerb at both corners. If the gap is less than 10mm then check the lower most long length of the builder's kerb in the same way. If the gap here is also less than 10mm then the rooflights width position (the distance between the external kerb and the internal fixing face of the rooflight) can be set at 10mm and move onto step 5.

If the combined gap of the top corner and bottom corner is greater than 20mm or there is an individual gap greater than 10mm, but in either case the builder's kerb is within the extremes size limit in terms of its overall width, then the rooflight should be set so that its internal fixing face would be touching the widest point of the builder's kerb along the top edge, meaning that other areas including the first bay may need to be packed significantly so that the edge of the rooflight over sails the external periphery of the builder's kerb at all points. Note in terms of tolerance the rooflight is designed to be 20mm wider than the external width of the builder's kerb which would allow it to accommodate a bow of up to 20mm.

### Step 5. Positioning The Rooflight - Length

Having previously measured the length of the builder's kerb, you will be aware of whether it is the same size or greater than the size indicated on the Duplus information details. Once started the rooflights position is extremely difficult and time consuming to move, so it is vital to consider any variation or bowing on plan of the kerb in its length to ensure that the builder's kerb extremes do not clash with the rooflight framework.

If there are any 'wide' points on the external vertical surface of the builder's kerb (only the top 75mm) then the kerb extremes should be measured to determine the maximum kerb length. Note in terms of tolerance the rooflight is designed to be 20mm wider than the external width of the builder's kerb which would allow it to accommodate a bow of up to 20mm.

Cont'd

**Need help? Call us on 0116 2610 710**



## Step 5. Positioning The Rooflight - Length (cont'd)

If the builder's kerb and Duplus Information details indicate the same kerb size then position the end bay with a 10mm gap between the external curb and the internal fixing face of the rooflight and move to Step 6.

If the external builder's kerb extreme size is different to that indicated on the Duplus Information details you must adjust the fixing position of the first bay frame to accommodate for this size variation. For example, if the builder's kerb is measured between its extremes as 1000mm wide x 7512mm long whereas Duplus Information details state the rooflight is manufactured to suit an external curb width of 1000mm x 7500mm then the kerb is 12mm longer than anticipated. The adjustment is as follows:

$$20\text{mm} - (\text{length of builder's kerb} - \text{length of Duplus stated builder's kerb}) / 2$$

In our example this equates to

$$20\text{mm} - (7512\text{mm} - 7500) / 2 =$$

$$20\text{mm} - 12\text{mm} / 2 = 4\text{mm gap}$$

(between the external kerb and the internal fixing face of the rooflight)

Likewise if the builder's kerb was smaller for example, measuring say 7490mm long between extremes then the following adjustment would be necessary

$$20\text{mm} - (7490\text{mm} - 7500\text{mm}) / 2 =$$

$$20\text{mm} - -10\text{mm} / 2 = 15\text{mm gap}$$

(between the external kerb and the internal fixing face of the rooflight)

To help position the rooflight effectively please complete the following:-

### **Builders Kerb dimensions – please complete**

#### **Key dimensions required to position the rooflight**

**Measuring from corner to corner of the rooflight in its length on the vertical face of the builder's kerb to determine size of kerb bow.**

**Size A Gap to string line from highest point to top left corner** \_\_\_\_\_mm

**Size B Gap to string line from highest point to top right corner** \_\_\_\_\_mm

**Size C Gap to string line from lowest point to bottom left corner** \_\_\_\_\_mm

**Size D Gap to string line from lowest point to bottom left corner** \_\_\_\_\_mm

Cont'd

**Need help? Call us on 0116 2610 710**



Cont'd

Measuring all points on top of kerb to determine length of kerb between its extremes.

Size E (must be within +/- 20mm of the dimensions advised by Duplus)

1, Overall builder's kerb length between extremes \_\_\_\_\_ mm

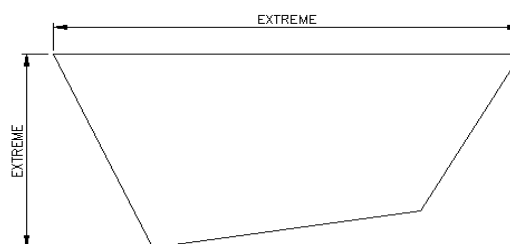

2, Duplus builder's kerb length \_\_\_\_\_ mm

Difference \_\_\_\_\_ mm

Setting out position of the first frame is as follows:-

In its **Width** the gap between the internal fixing face of rooflight and builder's kerb

If the sizes of A,B,C & D are all less than 10mm. Then the gap is 10mm.

Otherwise set the overhang as size A if your first installed bay is on the left hand side of the rooflight opening or B if starting on the right hand side of the rooflight opening.

In its **Length** the gap between the internal fixing face of rooflight and builder's kerb

$20\text{mm} - (\text{length of builder's kerb} - \text{length of Duplus stated builder's kerb}) / 2 =$

**FINAL NOTE** The accurate setting out of the first rooflight bay is critical to ensure that the builder's kerb extremes do not clash with the rooflight framework.

### Step 6. Fitting The First Frame

The first frame to be fitted will be one of the two end frames of the rooflight. Look for a unit with identical metal framing to three sides and with two silver metal connection pieces projecting from the open ends of the aluminium frame this is the first frame to fix. Note only one of the three sided frames has factory fitted extension pieces.

Place this end frame with the correct perimeter gap as determined by Steps 4 & 5. Wedge packers between the internal fixing face of the rooflight and the builders kerb to the same gaps as determined by Steps 4 &5.

Drive supplied screws half way in through all of the pre drilled holes in the rooflight frame and then hang the horseshoe packers from the screws between the rooflight frame and the builders kerb, the packers being the same thickness as determined in steps 4 & 5. Repeat on all three sides. Check that the position of the rooflight is correct and then fully fix the screws into the kerb ensuring that each screw is fully packed and that no deformation of the aluminium rooflight frame occurs when the fixings are fully tightened.

Cont'd

**Need help? Call us on 0116 2610 710**



### Step 7. Connecting an Additional Frame

Each additional frame (excluding the other end frame) will have two factory fitted silver metal 'internal' connection pieces projecting from the open ends of the aluminium frame. Place the next glazed frame onto the builder's kerb adjacent to the previously fitted frame with the internal metal connection pieces on the opposite side.

Line up the internal connection pieces of the fitted bay with the open slots in the additional frame and gently slide the additional bay onto the fitted bay. Ensure that the fitted gasket to the underside of the rooflight framework is not unseated and that there is no gap between this gasket and the gasket of the previously fitted bay. Ensure that there is full metal contact between frames, if necessary tap the additional frame (not the glass) into place using a timber mallet applying an equal force on both sides.

### Step 8. Connecting Internal Support Angles

If the rooflight frames are fitted with an angle bonded to the glass, (these will be present on wide span rooflights) from underneath the rooflight, push the bolt fixings supplied through the oversized holes in the angle. With all bolts through the holes apply the nuts and tighten each bolt equally until all are fully tightened. Ensure that each angle is fixed in an identical manner with nuts one side and bolt heads the other.

### Step 9. Fitting the External Connection Piece

With the rooflight frames tight together push the predrilled external connection piece into the fixing slot - it will drop down into position. Do this on both sides of the rooflight as per drawing SBCD7&9 and fix in place using the supplied screws.

### Step 10. Fix Additional Frame to Builders Kerb

Drive supplied screws half way in through all of the pre drilled holes in the rooflight frame and then hang the horseshoe packers from the screws between the rooflight frame and the builder's kerb. Install a sufficient number of packers until the frame is fully wedged. Repeat on all three sides. Check that the position of the rooflight is correct and then fully fix the screws into the kerb ensuring that each screw is fully packed and that no deformation of the aluminium rooflight frame occurs when the fixings are fully tightened.

### Step 11. Fitting Additional Frames

Repeat Steps 7, 8, 9 and 10 until all frames are fitted including the last end frame.

### Step 12. External Clean Down

Clean down the external glass and remove any protective tapes, labels etc.

### Step 13. Mastic Sealant Application

With the supplied black mastic, where the frames abut, apply mastic inside the frame (the internal L). No mastic is to be applied to any external frame surfaces.

Measure the exposed edge of the glass and cut the supplied expanding foam backing rod to length.

Cont'd

**Need help? Call us on 0116 2610 710**



### Step 13. Mastic Sealant Application (cont'd)

If the glass is fitted with internal support angles push the expanding foam backing rod into the gap between the glass edges ensuring that the backing rod is wedged sufficiently into place but take care not to disturb the silicone applied to the metal to metal frame joint.

If the glass is not fitted with internal supports, then engage the backing rod so that it is positioned 6-8mm below the top face of the glass.

Apply the black mastic supplied to the glass to glass edge, apply sufficient quantity so that when the mastic is tooled off it is flush with the top edge of the double glazed unit. Tool off the mastic and clean away any overspill from the glass and frame.

### Step 14. Apply External Snap On Cover Clips

Apply the snap on screw concealing cover clips to the perimeter of the rooflight. All works externally are now complete.

### Step 15. Check for Gaps Beneath the End Frames

Check that there are no gaps under the end bay framework in the width. If there are wedge packers under the framework and seal internally.

### Step 16. Apply the Internal Foam Tape

Apply the supplied foam tape to the internal perimeter of the rooflight metal frame. Starting in one corner remove the backing tape from the glue side of the foam and push the adhered side against the metal framework/black gasket. Take care not to touch the glass with the adhesive side as marks on the underside of the glass will be visible and will have to be cleaned off. Work the foam against the frame, between the angles if fitted and along the entire length of the rooflight internally. Do not cut the foam until you reach the other end of the rooflight. Fit the foam internally to all 4 sides of the rooflight. Clean down the inside of the installation.

### Step 17. Internal Mastic Seal

If the glass is not fitted with internal angle supports apply the supplied black mastic to the glass to glass joints internally, apply sufficient quantity so that when the mastic is tooled off it is flush with the bottom edge of the double glazed unit. Tool off the mastic and clean away any overspill from the glass and frame.

The rooflight is now ready for inspection and hand over.

**Need help? Call us on 0116 2610 710**



## 5.0 Standard Glass Specification

### Units below 1.2m<sup>2</sup>

Outer Pane	4mm toughened
Cavity	20mm argon with warm edge spacer
Inner Pane	4mm low E coated Toughened
Light transmission	80%
Solar Gain	0.63
Centre Pane U-value	1.1Wm <sup>2</sup> K
Weight	20Kg/m <sup>2</sup>

### Units above 1.2m<sup>2</sup>

Outer Pane	6mm toughened
Cavity	16mm argon with warm edge spacer
Inner Pane	6mm low E coated Toughened
Light transmission	78%
Solar Gain	0.61
Centre Pane U-value	1.1Wm <sup>2</sup> K
Weight	30Kg/m <sup>2</sup>

Need help? Call us on 0116 2610 710



## 6.0 Glass Information

Glass Type	Light Transmission (LT)	Total Solar Energy Transmittance (g value)	Centre Pane U-value
4mm Toughened / Argon / 4mm Toughened Soft Coat Low E	80%	63%	1.1 W/m <sup>2</sup> K
4mm Toughened Grey Tint / Argon / 4mm Toughened Soft Coat Low E	50%	49%	1.1 W/m <sup>2</sup> K
4mm Toughened Blue Tint / Argon / 4mm Toughened Soft Coat Low E	57%	41%	1.1 W/m <sup>2</sup> K
6mm Toughened / Argon / 6mm Toughened Soft Coat Low E	78%	61%	1.1 W/m <sup>2</sup> K
6mm Toughened Grey Tint / Argon / 6mm Toughened Soft Coat Low E	38%	35%	1.1 W/m <sup>2</sup> K
6mm Toughened Blue Tint / Argon / 6mm Toughened Soft Coat Low E	47%	33%	1.1 W/m <sup>2</sup> K
6mm Toughened HP Solar Control (Neutral) / Argon / 6mm Toughened	70%	40%	1.1 W/m <sup>2</sup> K

**Light Transmission (LT)** is the proportion of visible light at near normal incidence that is transmitted through the glass.

**Total Solar Energy Transmittance (g-value)** is the fraction of solar radiation at near normal incidence that is transferred through the glazing by all means.

**U-Value** is the rate of loss of heat per square metre, under steady state conditions, for a temperature difference of one Kelvin between the inner and outer environments separated by the glass.

**HP Solar Control** is Guardian Sunguard high selective super neutral coating that gives an excellent solar control performance and also a high light transmission.

**Tint** is a glass that has a coloured tint which gives excellent solar control, but has reduced light transmission.

Need help? Call us on 0116 2610 710



## 7.0 Glass Breakage

- 6.1 Glass breakages are not covered under warranty. Should you experience a glass break please contact Duplus Architectural Systems Head office to order a replacement rooflight.

## 8.0 General Cleaning & Maintenance

- 8.1 The appearance, durability and performance of Duplus products, regardless of the material from which they are made, are always dependent on regular cleaning and maintenance. Cleaning therefore contributes considerably to the effective life of the system. All Duplus products should be cleaned regularly and at time intervals depending upon the accumulation of dirt. We should expect a minimum regime of 6 monthly clean and maintenance checks.
- 8.2 Those engaged on maintenance or cleaning work should use suitable equipment (see BS8213). Experienced operatives should be employed particularly in respect to rooflight/high level cleaning.
- 8.3 Note under no circumstance should you attempt to walk on or load Duplus rooflight products regardless of their fragility status.**
- 8.4 The cleaning process is generally uncomplicated, consisting of washing down with warm water and mild detergent. Abrasive, caustic and chemical treatments are unnecessary, and may actually cause damage to the exposed surfaces of our products. A soft cloth or brush may be used to remove persistent contamination. However, care should be taken to avoid rubbing dirt into the system components. In the case of paint or bitumen splashes, white spirit applied with a soft cloth may be used with care, we would recommend a small area is tested first but do not allow white spirit to run onto unaffected areas. A final rinse with clean water will complete the process.
- 8.5 The product should be checked for movement on the kerb, if movement is found remove fixing snap in cover clip and check tightness of screws.

### Important Note:

- 8.6 An annual review of perimeter silicone should be made to confirm that the perimeter seal between the glass and frame is intact. If the seal is not intact i.e., if this seal has been removed or degraded, the area should be cleaned and dried and re-sealed with Dow Corning 791 silicone sealant at the earliest opportunity. If water sits against the edge of a double glazed unit because the outer seal is no longer intact, Duplus will accept no responsibility of the glass unit breakdown as a result. Please be aware, although rare, it has been known for birds to peck away at silicone.
- 8.7 An annual review of the glass should be made and in the very rare event there appears to be any signs of glass movement, please contact Duplus at the earliest opportunity.

**Need help? Call us on 0116 2610 710**



## 9.0 Emergency Contact Information

### Office Hours

Monday – Thursday: 8am – 12.45pm 1.30pm – 5pm

Friday: 8.30am – 1pm

### Telephone

0116 2610710

### Fax

0116 2610539

### Email

[sales@duplus.co.uk](mailto:sales@duplus.co.uk)

**Need help? Call us on 0116 2610 710**

# 10.0 DRAWING REFERENCE

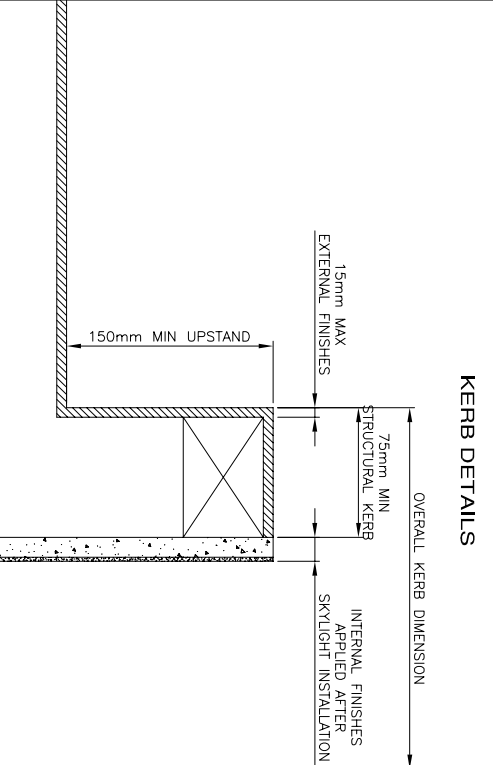
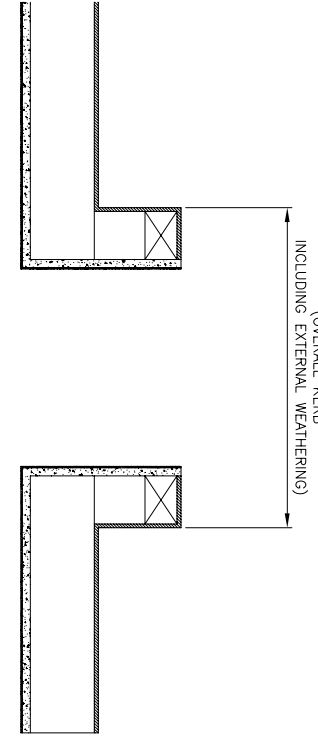
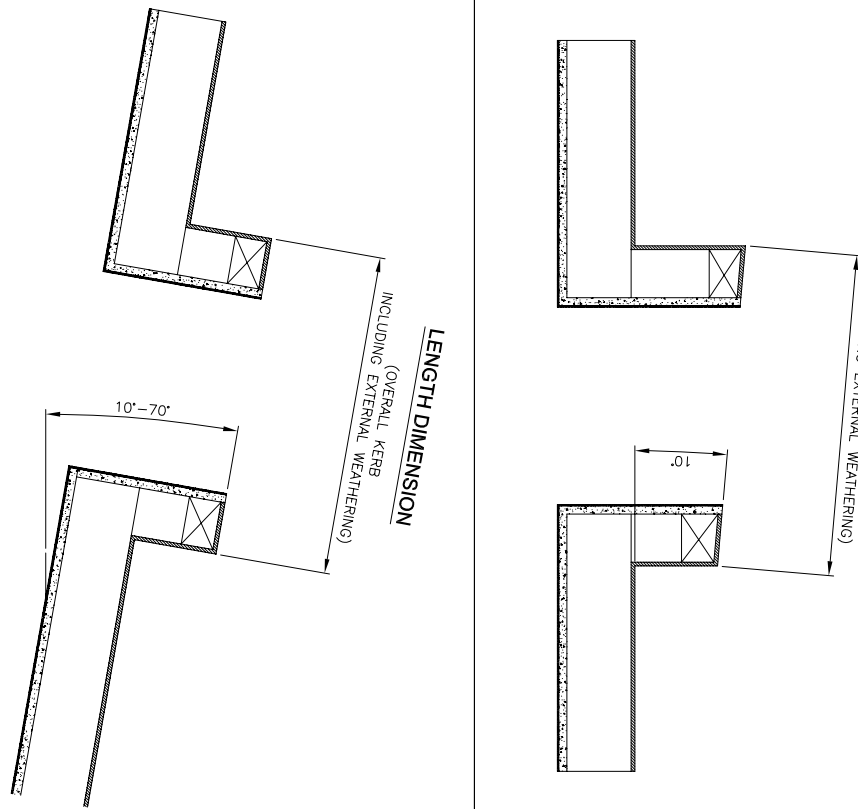
<table border="1" style="width: 100%; border-collapse: collapse;"> <tr> <td style="width: 5%;">Rev</td> <td style="width: 15%;">Date</td> <td style="width: 80%;">Description</td> </tr> <tr> <td> </td> <td> </td> <td> </td> </tr> </table>	Rev	Date	Description				<table border="1" style="width: 100%; border-collapse: collapse;"> <tr> <td style="width: 5%;">Rev By</td> <td style="width: 85%;"> </td> <td style="width: 10%;"> </td> </tr> </table>	Rev By			<p>THIS DRAWING REMAINS THE COPYRIGHT OF DUPUS ARCHITECTURAL SYSTEMS LTD. AND MUST NOT BE REPRODUCED WITHOUT PRIOR AUTHORIZATION.</p> <p>370 Melton Road, Leicester LE4 7SL Tel: 0116 2610710 Fax: 0116 2610539</p> 	<p>DUPUS WORKS-EACH MANUFACTURED COMPONENT ± 1 mm SITE INSTALLED COMPOSITE FRAMES ± 10 mm</p> <p>Scale: N/A</p> <p>Drawn: Title: Kerb details</p> <p>Job No: Dwg No: SB001</p> <p style="text-align: right;">REV</p>
Rev	Date	Description										
Rev By												
 <p><b>KERB DETAILS</b></p> <p>150mm MIN UPSTAND</p> <p>15mm MAX EXTERNAL FINISHES</p> <p>75mm MIN STRUCTURAL KERB</p> <p>INTERNAL FINISHES APPLIED AFTER SKYLIGHT INSTALLATION</p> <p>OVERALL KERB DIMENSION</p>		<p><b>WIDTH DIMENSION</b></p> <p>(OVERALL KERB INCLUDING EXTERNAL WEATHERING)</p> 										
<p><b>CRITICAL DIMENSIONS WHEN ORDERING YOUR FIXED ROOFLIGHT.</b></p> <p>WIDTH DIMENSION &amp; EITHER OF THE LENGTH DIMENSIONS AS ILLUSTRATED ABOVE DEPENDING ON YOUR ROOF DESIGN (FLAT ROOF OR PITCHED ROOF) ARE REQUIRED IN ORDER FOR DUPUS TO PROCEED.</p> <p>AN OVERALL EXTERNAL KERB TOLERANCE OF ±10mm CAN BE ACCOMMODATED.</p> <p>IF KERB DIMENSIONS ARE OUTSIDE THE SPECIFIED TOLERANCE THE SKYLIGHT FRAME MAY NOT FIT OVER THE KERB AS DESIGNED.</p> <p>STRUCTURAL KERB THICKNESS, 75mm MIN KERB THICKNESS IS CRUCIAL TO ENSURE THE ROOFLIGHT IS SUITABLY SUPPORTED.</p>		<p><b>LENGTH DIMENSION</b></p> <p>(OVERALL KERB INCLUDING EXTERNAL WEATHERING)</p>  <p>10'-0"</p>										

## ENLARGED SECTION DETAIL

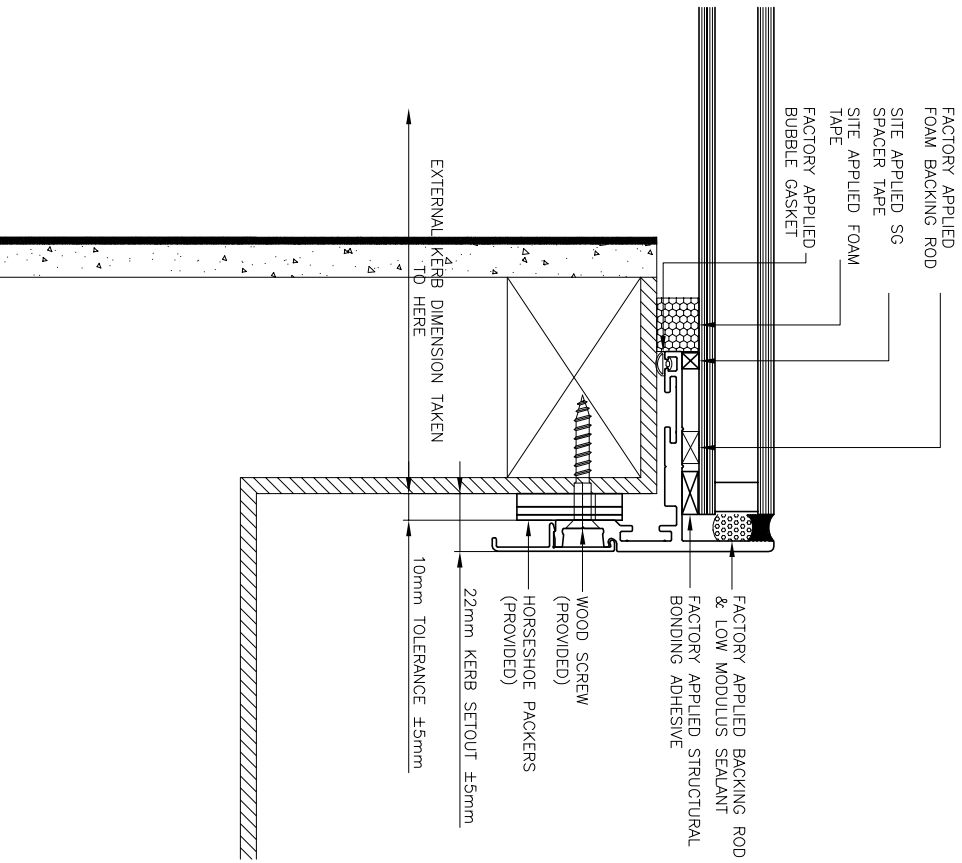

## DIMENSIONAL KERB DETAIL

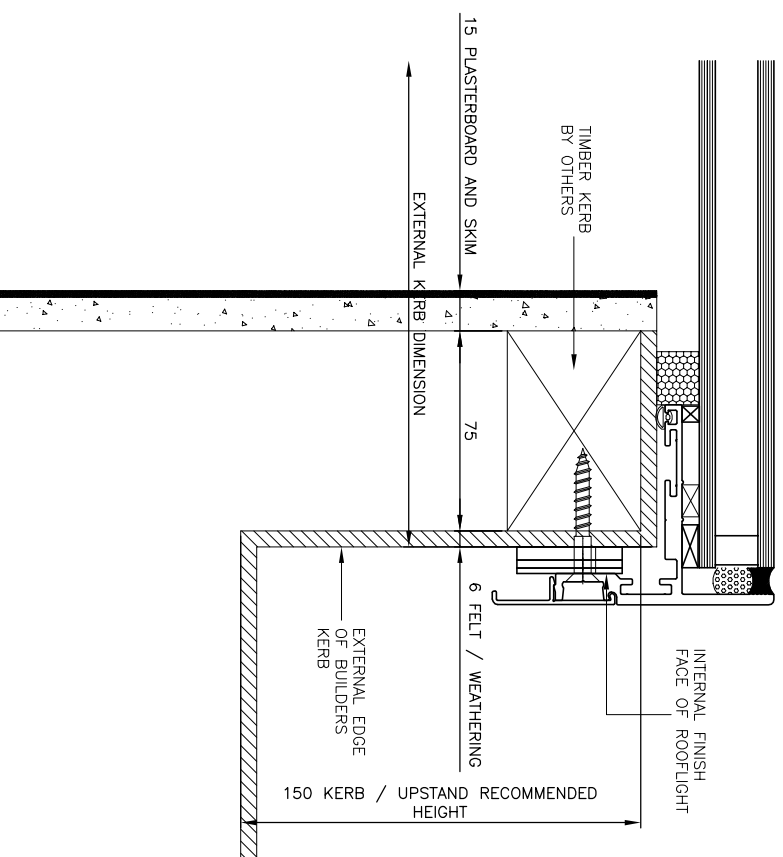

Rev	Date	Description

Rev By

THIS DRAWING REMAINS THE COPYRIGHT OF DUPPLUS ARCHITECTURAL SYSTEMS LTD. AND MUST NOT BE REPRODUCED WITHOUT PRIOR AUTHORIZATION.

370 Melton Road, Leicester, LE4 7SL  
 Tel: 0116 2610710  
 Fax: 0116 2610539



DUPPLUS WORKS - EACH MANUFACTURED COMPONENT ± 1 mm SITE INSTALLED COMPOSITE FRAMES ± 10 mm  
 Scale: N/A  
 Drawn:

Title: Section through continuous kerb

Proj No: SB005

REV

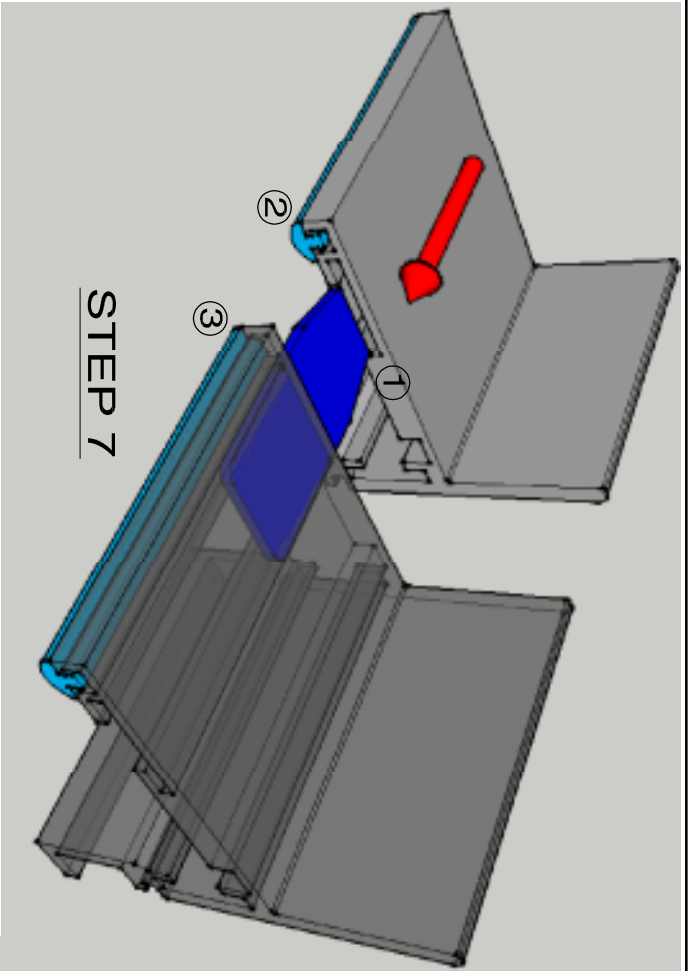

**STEP 7**

**STEP 7**  
 LINE UP THE INTERNAL CONNECTION PIECE (1) OF THE FITTED BAY WITH THE OPEN SLOTS IN THE ADDITIONAL FRAME AND GENTLY SLIDE THE ADDITIONAL BAY ONTO THE FITTED BAY. ENSURE THAT THE FITTED GASKET TO THE UNDERSIDE OF THE ROOFLIGHT FRAMEWORK IS NOT UNSEATED AND THAT THERE IS NO GAP BETWEEN THIS GASKET (2) AND THE GASKET OF THE PREVIOUSLY FITTED BAY (3)

**STEP 9**  
 PUSH THE PREDRILLED EXTERNAL CONNECTION PIECE (4) INTO THE FIXING SLOT AND FIX IN PLACE USING THE SUPPLIED SCREWS.

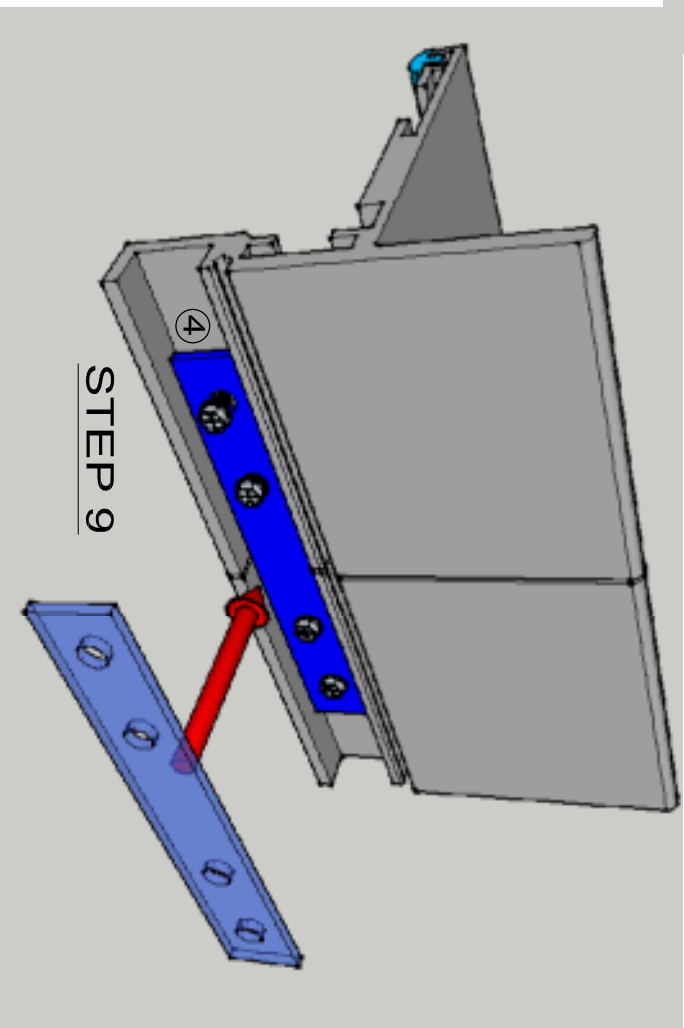

**STEP 9**

Rev	Date	Description

Rev By

THIS DRAWING REMAINS THE COPYRIGHT OF DUPLUS ARCHITECTURAL SYSTEMS LTD. AND MUST NOT BE REPRODUCED WITHOUT PRIOR AUTHORIZATION.

370 Nelson Road,  
 Leicester  
 LE4 7SL  
 Tel: 0116 2610710  
 Fax: 0116 2610539

Duplus items with reference (S) are manufactured in accordance with BS4973:2009, BS3950:197 (windows and curtain walling) PAS24 (doors) and are glazed in accordance with the recommendations given in BS5262



DUPUS WORKS-EACH MANUFACTURED COMPONENT ± 1 mm SITE INSTALLED COMPOSITE FRAMES ± 10 mm  
 Scale: NTS  
 Drawn:

Contract:  
 Title: SB CONNECTION DETAIL

Job No:  
 Proj No: SB CD7&&9  
 Ref: A