



ARCHITECTURAL SUN CONTROL



HOME OF OXYGEN

An optimal indoor climate is healthy and gives a good feeling. Duco developed its Green Building Solution for this reason where basic ventilation, intensive ventilation and sun control are combined. This enables us to guarantee an optimum air quality and thermal

comfort, for both residential and non-residential housing, with a minimum of energy consumption. Because Duco's solutions are natural and energy efficient. They give homes and non-domestic buildings an aesthetic added value. **Duco , Home of Oxygen**

DUCO
Ventilation & Sun Control

[→ Table of contents](#)

Architectural Sun Control	4-7
DucoSun	
DucoSun 100 C	8-9
DucoSun 150 CF	12-13
DucoSun 100 D – 150 D	14-15
DucoSun Ellips	18-19
DucoSun Cubic	22-23
DucoSun Linear	26-27
DucoSun Wing	28-29
Span tables	30-33
DucoSlide	36-37
LuxFrame	38-39
SlimFrame	40-41
Sliding systems	44-45

Receive the most sunlight and the least heat

Architectural Sun Control: aesthetic as well as functional

Today the use of glass in architecture is becoming more and more prevalent. Even full glass façades are built in some cases. The ideal living room and workplace temperature range is between 22 and 24° C. Internal temperatures on hot days can even be as high as 33° C or more when glass is used.

Duco's external sun control systems reduce the thermal heat gain in a building in a natural and energy efficient way and reduce in this way the cooling load up to 30%. Investing in sun control is, therefore, an excellent solution that will soon reach payback.

In addition, the sun control systems allow most of the sunlight to enter while blocking solar heat gain and keeping out sun glare.

Sufficient daylight in a building is a guarantee of a pleasant visual comfort, but sun control also ensures that thermal comfort conditions are maintained during the hot summer months. They provide privacy screening for glass façades without obstructing the view from inside to the exterior.

In combination with ventilative cooling, architectural sun control is the ideal alternative to an energy-wasting air-conditioning system that guarantees a healthy and comfortable indoor climate in a natural manner.

Architectural sun control is an essential part of the total concepts that Duco develops. The user's health is given the highest priority with **DUCO at WORK**, **DUCO at SCHOOL** and **DUCO at CARE** thanks to a well through-out solution of natural daytime ventilation in combination with external shading and ventilative cooling.

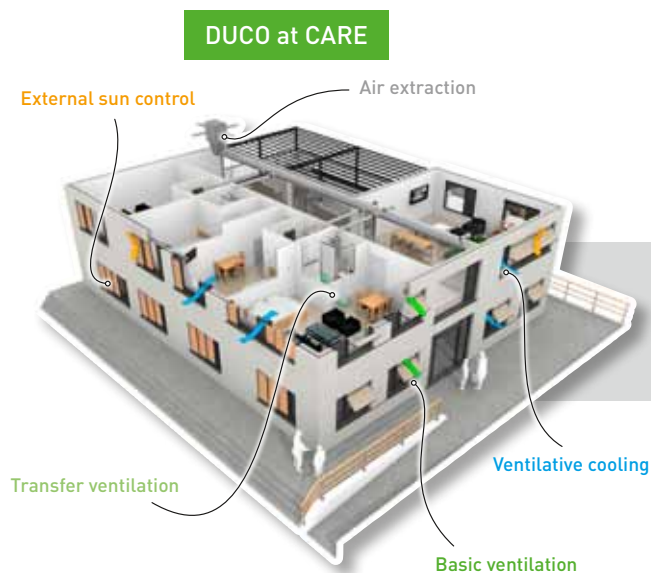
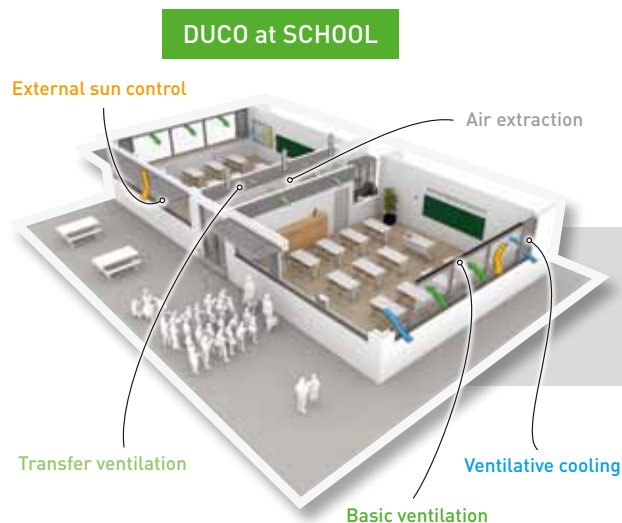
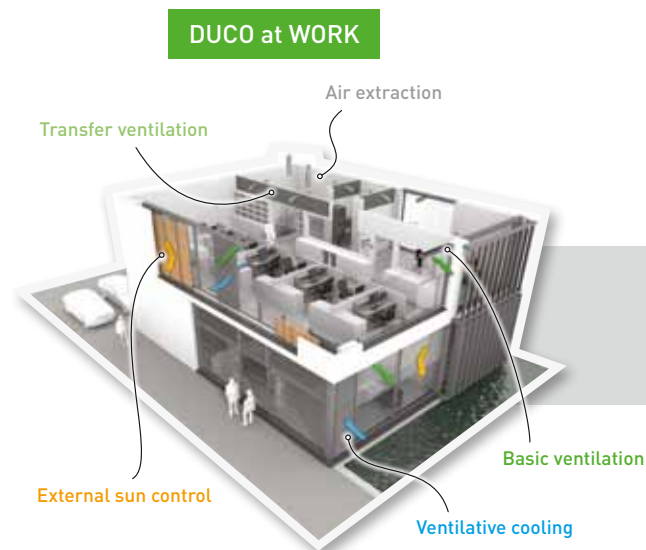

DucoSun

structural sun control

The Duco's sun control systems available cover a wide range of options. Systems are available with fixed blades or **adjustable blades**, with discrete or eye-catching designs and may be used in vertical or horizontal form. Which sun control you choose, depends on the budget available, the technical options and, of course, on what you like. Whatever system you may choose: Duco ensures an optimum balance between minimum solar heat gain and maximum daylight entry without any resulting colour changes.

→ Types

1. DucoSun C – DucoSun CF - DucoSun D

External sun control systems, which have their aluminium sun control blades clipped on to plastic blade holders. The blade holders are pre-fitted to the aluminium support profile with the patented Duco **Slide and Click system**. The blades come in three different types : C, CF or D.

Materials

→ **Aluminium:** EN AW – 6063 T66

→ **Surface treatment:**

Standard natural anodising (15-20 µm)
(VB6/A20/VOM1)

Stove enamelled and polyester powder coated
(60-80µm)

→ **Synthetic parts:**

Polyamide, glass fibre reinforced and UV-resistant

2. DucoSun Ellips - DucoSun Cubic - DucoSun Linear - DucoSun Wing

External sun control systems with either fixed or moveable aluminium sun control blades fitted to the support system. The austere lines of the sun control blades improve the **aesthetic appeal**. A choice of four different blade types is available: Ellips, Cubic, Linear and Wing.

Materials

→ **Aluminium:** EN AW – 6060 T66

→ **Surface treatment:**

Standard natural anodised finish (15-20 µm)
(VB6/A20/VOM1).

Stove enamelled and polyester powder coated
(60-80 µm)

→ Installation options

Horizontal installation

Horizontal sun control systems minimise solar heat gain during the warmer periods of the year (May-September) but maximise solar gain in the colder months of the year with low level sun angles (October-April). This ensures optimum energy performance.

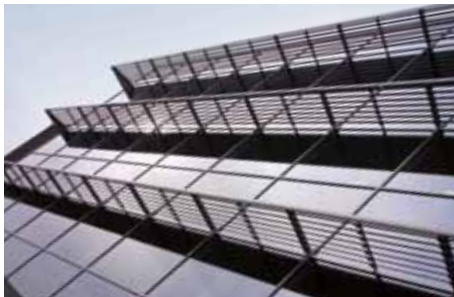

Vertical installation

Vertical sun control systems provide maximum privacy but, at the same time, allow a view to the outside. Vertical sun control systems offer room darkening capabilities.



DucoSun Ellips, DucoSun Cubic and DucoSun Linear Series sun control blades for vertical applications can be installed either vertically or horizontally.



→ Strength testing

The strength of external sun control systems is best assessed through wind tunnel testing where the **maximum air streams** are created. Duco has its sun control systems tested at the von Karman Institute in Brussels, an international leading-edge and independent institute for high technology research in fluid dynamics.

All DucoSun systems presented in this product brief have been tested in the laboratories of Duco and at the von Karman Institute. To this effect, Duco has developed an **application** for strength calculations.

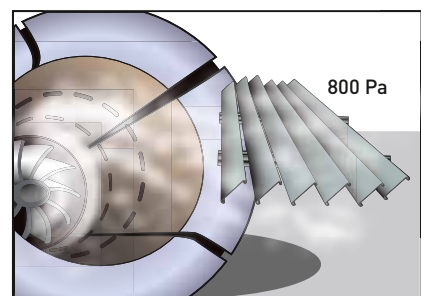

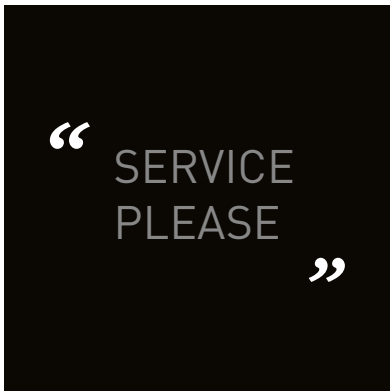

We inspire at www.duco.eu



Duco's R&D department is constantly developing and testing new solutions using the latest cutting-edge technologies. Duco works in partnership with reputable institutions such as the WTCB (Wetenschappelijk en Technisch Centrum voor het Bouwbedrijf; Scientific and Technical Centre for the Building Trade), the von Karman Institute, etc. Duco's knowledge and many years of experience ensure that a suitable solution can be offered for every one of your projects.

... Like us



Follow us ...

Duco's project team will be delighted to help you make a responsible choice in the selection of the correct sun control system for your specific projects. To this end, the team uses proprietary software, among other things, to perform all the required calculations including strength calculations, calculations of the correct spans and of the substructure fixing options. The ideal shadow angles are calculated as well. Here, consideration is also given to façade orientation, the path of the sun, etc.

→ www.duco.eu

- Professional intersection planes and fitting drawings.
- **Specification service:**
 - STABU certified specification text for each type of sun control device.
- **Fitting and installation instructions** on request.



DucoSun 100 C

DucoSun 100 C series sun control devices are architectural component systems with fixed C blades. The patented Duco slide and click system enables quick and straightforward fitting of the sun control blades at fixed blade angles to the support system.

- Straightforward component system.
- Sun control blades with discrete C-shaped design.
- Quick to install using the patented slide and click system.
- Fitting applications specific to any structural technical situation.

→ Slide and click system

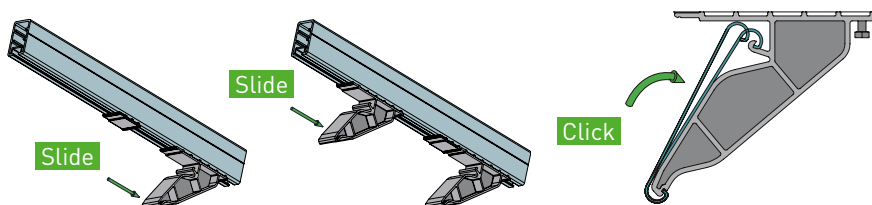

→ DucoSun 100 C underslung

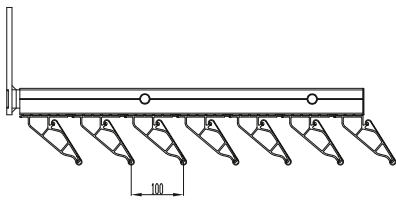

→ DucoSun 100 C overslung

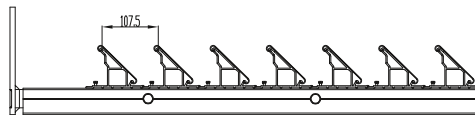

→ DucoSun 100 C vertical

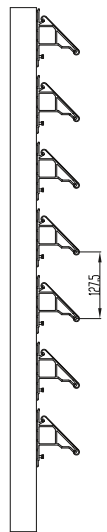

→ DucoSun 100 C intermediate

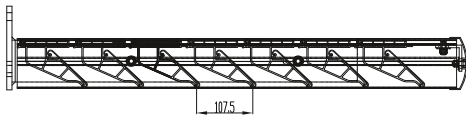

→ DucoSun 100 C framed

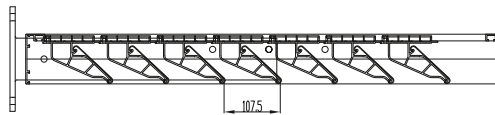

DucoSun 100 C Overview Table			
	Blade pitch	Slope	Finishing options:
Underslung	100 mm	60°	With plastic stop or With fascia profile: 150 Series flat, 175 Series flat, 90 Series full bullnose
Overslung	107.5 mm	45°	With plastic stop or With fascia profile: 150 Series flat, 175 Series flat, 90 Series full bullnose
Intermediate	107.5 mm	45°	With fascia profile: 100 Series, semi-bullnose
Framed	107.5 mm	45°	With frame profile 100 Series full bullnose or 100 Series flat
Vertical installation	127.5 mm	45°	



HOME OF OXYGEN







DucoSun 150 CF

DucoSun 150 CF is an architectural component system featuring **fixed sun control blades**. The patented Duco **slide and click system** enables quick and straightforward fitting of the sun control blades at fixed blade angles to the support system.

150 CF Series sun control blades combine the functional advantages of the 100 C Series basic blade with the appealing ellipsoid design of the DucoSun Ellips blade. The blades are extremely strong. That is why much larger spans can be covered with fewer support profiles.

- Straightforward component system.
- Sun control blades featuring an appealing “ellipsoid” design.
- Quick to install using the patented slide and click system.
- The rigidity of the CF-shaped sun control blades allows large spans.
- Large blade pitch (centre-to-centre distance between 2 blades).

→ Slide and click system

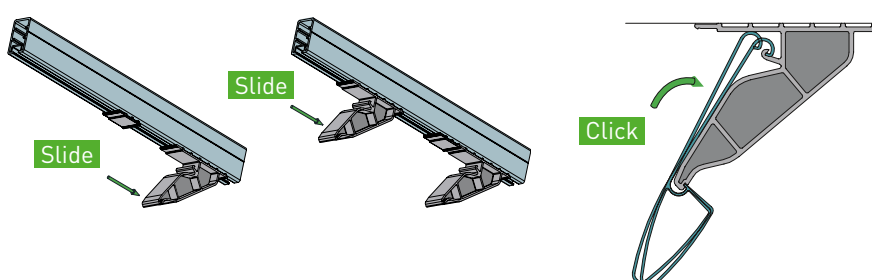

→ DucoSun 150 CF underslung

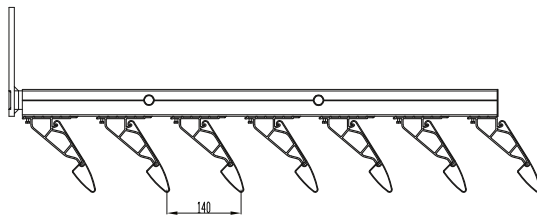

→ DucoSun 150 CF overslung

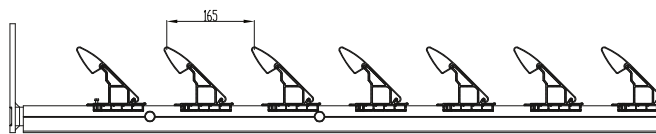

→ DucoSun 150 CF vertical

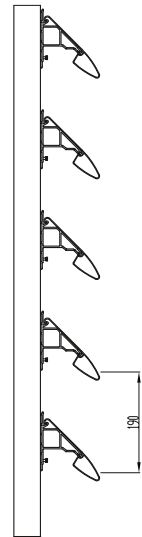

DucoSun 150CF overview table

	Blade end plate	Blade pitch	Slope	Finishing options:	
Underslung	Plastic stop for 150 CF Series blades	140 mm	60°	With plastic stop	or Fascia profile: 90 Series full bullnose
Overslung	Plastic stop for 150 CF Series blades	165 mm	45°	With plastic stop	or Fascia profile: 90 Series full bullnose
Vertical installation	Plastic stop for 150 CF Series blades	190 mm	45°	-	-





DucoSun 100 D/150 D

DucoSun 100 D and DucoSun 150 D are both architectural component systems featuring **fixed sun control blades**. The patented **Duco slide and click system** enables quick and straightforward fitting of the sun control blades at fixed blade angles to the support system.

100 D and 150 D Series sun control blades combine the functional advantages of the 100 C Series basic blade with an appealing bullnose design. The blades are extremely strong. That is why much larger spans can be covered with fewer support profiles.

- Straightforward component system.
- Sun control blades featuring an appealing bullnose design.
- Quick to install using the patented slide and click system.
- The rigidity of the D-shaped sun control blades allows large spans.
- The blades can be finished with end plates.

→ Slide and click system

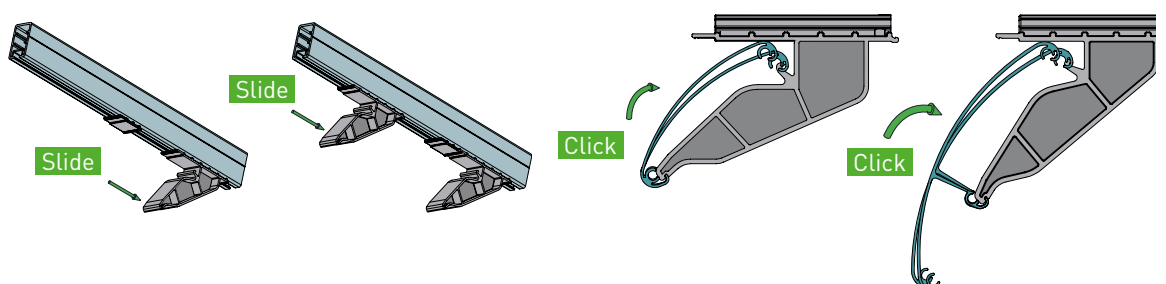

→ DucoSun 100 D underslung

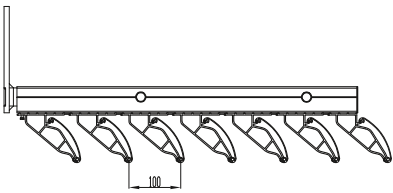

→ DucoSun 150 D overslung

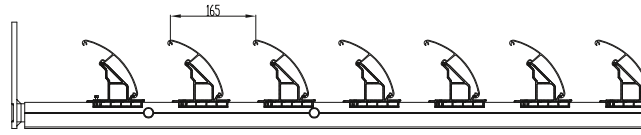

→ DucoSun 150 D vertical

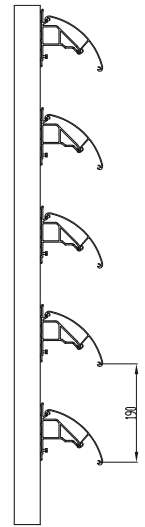

→ DucoSun 100 D intermediate

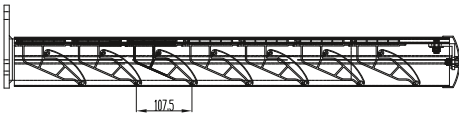

→ DucoSun 100 D framed

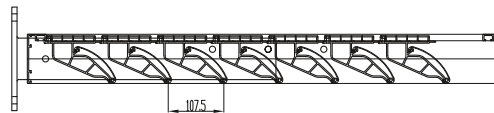

DucoSun 100 D/150 D overview table

	Type Blade	Blade end plate	Blade pitch	Slope	Finishing options	
Underslung	100 D	Aluminium end plate for 100 D Series blades	100 mm	60°	With plastic stop	or Fascia profile: 150 Series flat, 175 Series flat of 90 Series full bullnose
	150 D	Aluminium end plate for 150 D Series blades	140 mm	60°	With plastic stop	or Fascia profile: 90 Series full bullnose
Overslung	100 D	Aluminium end plate for 100 D Series blades	107.5 mm	45°	With plastic stop	or Fascia profile: 150 Series flat, 175 Series flat of 90 Series full bullnose
	150 D	Aluminium end plate for 150 D Series blades	165 mm	45°	With plastic stop	or Fascia profile: 90 Series full bullnose
Intermediate	100 D	Aluminium end plate for 100 D Series blades	107.5 mm	45°	Fascia profile: 100 Series, semi-bullnose	
Framed	100 D	Aluminium end plate for 100 D Series blades	107.5 mm	45°	Framing system 100 Series full bullnose or 100 Series flat	
Vertical installation	100 D	Aluminium end plate for 100 D Series blades	127.5 mm	45°	-	
	150 D	Aluminium end plate for 150 D Series blades	190 mm	45°	-	



HOME OF OXYGEN



COMPLETED PROJECT



DucoSun Ellips

This sun control system is available with either **fixed** or **electrically adjustable** sun control blades. They are installed to the support system on-site (either horizontally or vertically). This system allows for a **wide variety of blade mounting angles**. This ensures that the system can shade the area optimally regardless of the glazed surface and the position of the sun throughout the day.

The **ellipsoid blade styles** admit high levels of diffused daylight. They are available in seven different sizes: 100 – 150 – 200 – 250 – 300 – 350 – 400. DucoSun Ellips offers architects a wide freedom of design.

→ The ellipsoid blade styles admit high levels of diffused daylight.

→ The compact fitting dimensions provide optimal shading performance.

→ Available in a choice of 7 blade types.

→ Wide variety of fitting applications.

Basic components

→ Sun control blades

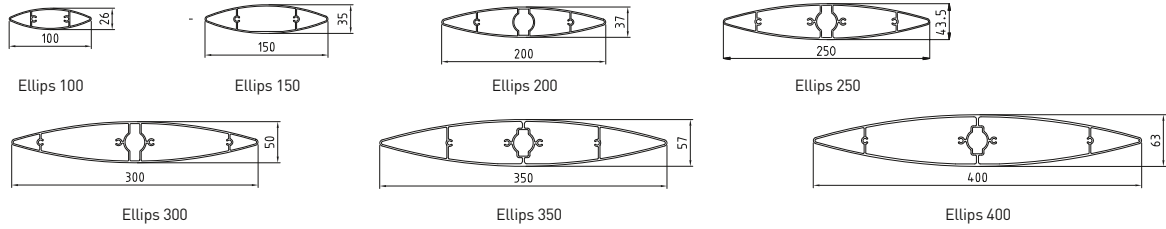

→ Support profiles

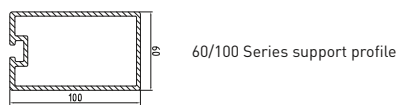

→ End caps



→ Blade holders

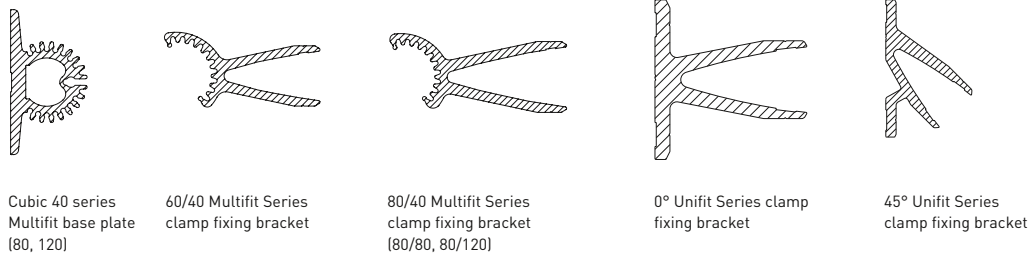

Systemen

→ DucoSun Ellips Intermediate

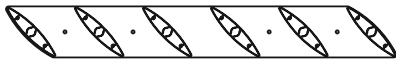

→ DucoSun Ellips Unifit :

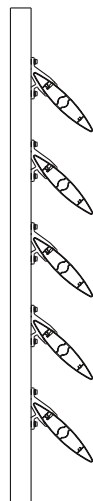

→ DucoSun Ellips Multifit

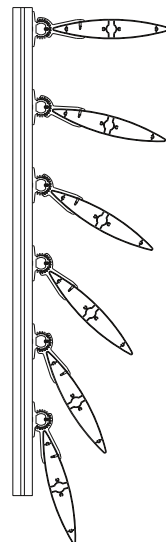

→ DucoSun Ellips adjustable

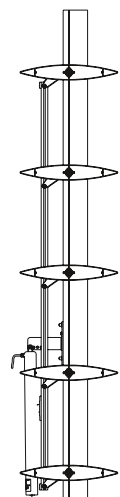

HOME OF OXYGEN







DucoSun Cubic

DucoSun Cubic is available with either **fixed** or **electrically adjustable** sun control blades. They are installed to the support system on-site (either horizontally or vertically). Depending upon the type, fixed sun control blades are fitted at a **blade mounting angle of 0° or 90°**. This, in conjunction with the **rectangular shape** of the sun control blade, produces a very **clean-cut effect**. When fully closed, the electrically adjustable sun control blades provide highly effective sun protection. The closed sun control blades and the façade face are aligned and, therefore, form a perfect unit.

The **rectangular blade styles** admit high levels of diffused daylight. They are available in a choice of four sizes: 150 – 200 – 300 and 400.

→ Clean-cut rectangular blade geometry.

→ The closed sun control blades and the façade face are aligned and, therefore, form a perfect unit.

Basic components

→ Sun control blades

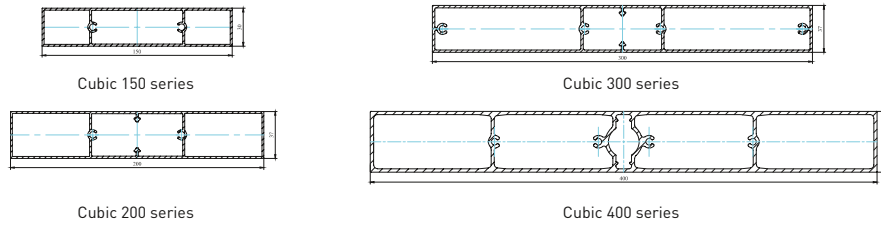

→ Support profiles

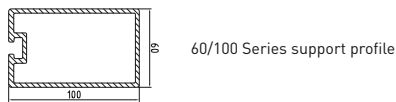

→ End caps



→ Blade holders

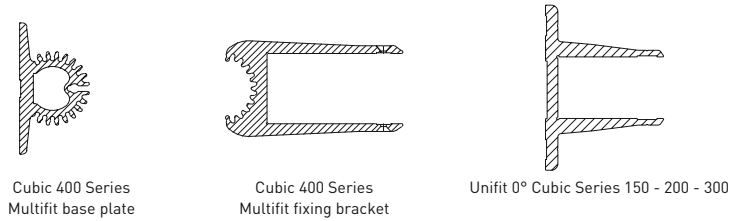

Systemen

→ DucoSun Cubic Intermediate

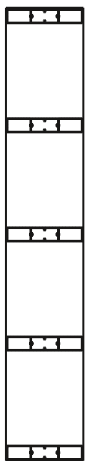

→ DucoSun Cubic Unifit

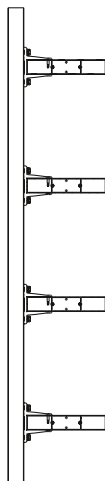

→ DucoSun Cubic Multifit

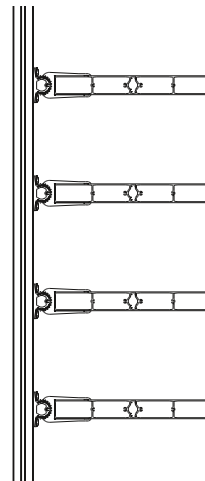

→ DucoSun Cubic Adjustable

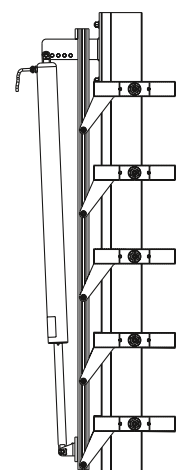

HOME OF OXYGEN





COMPLETED PROJECT



DucoSun Linear

DucoSun **Linear** Series is available with either **fixed** or **electrically adjustable** sun control blades. They are installed to the support system on-site (either horizontally or vertically). The fixed sun control blades are fitted at a **blade mounting angle of 45°**. Combined with the **parallelogram** shaped sun control blade, a very **beautiful effect**. When fully closed, the electrically adjustable sun control blades provide optimum solar protection. The closed sun control blades and the façade face are aligned and, therefore, form a perfect unit.

The ellipsoid **blade styles** admit high levels of diffused daylight. They are available in a choice of two sizes: 200 and 300.

- Very beautiful blade geometry (parallelogram).
- The closed sun control blades and the façade face are aligned and, therefore, form a perfect unit.
- Full sun control with blades closed.

Basic components

→ Sun control blades

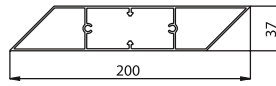

Linear 200 series blade

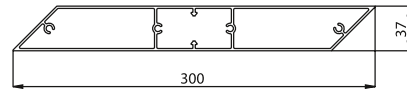

Linear 300 series blade

→ Support profiles

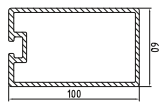

60/100 Series support profile

→ End caps



Linear Series 0° end cap

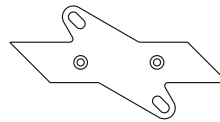

Linear Series 45° end cap

→ Blade holders

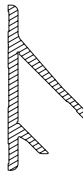

Unifit 45° Linear 200 -300

Systemen

→ DucoSun Linear Intermediate



→ DucoSun Linear Unifit

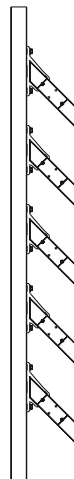

→ DucoSun Linear Adjustable

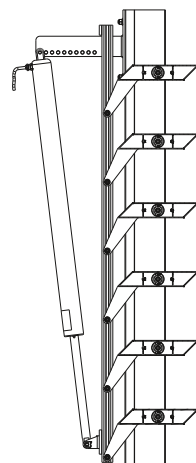

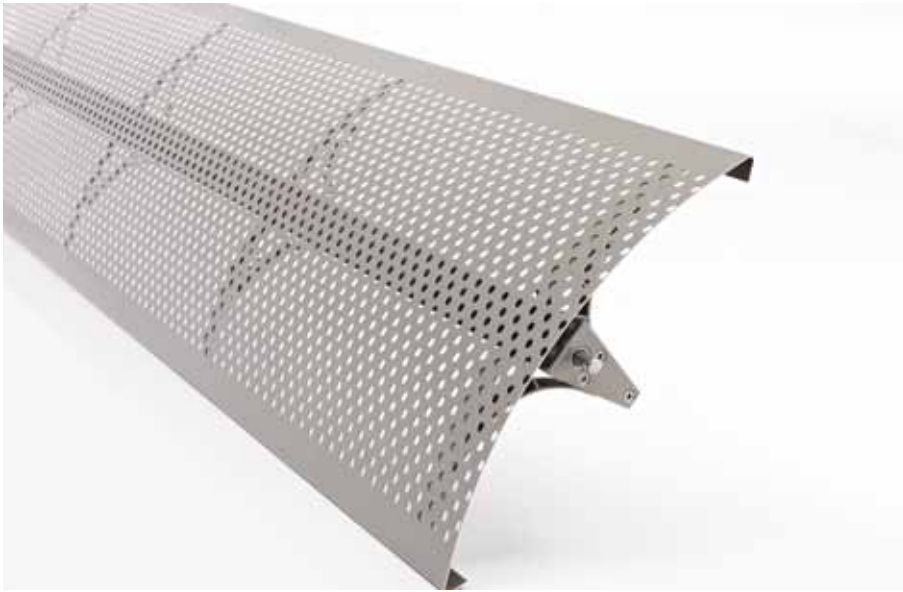

DucoSun Wing

The DucoSun Wing is **perforated** and achieves perfect harmony between solar control and shade control. The wing-shaped blade achieves an **urban design** and can be supplied in other perforations as well as with the standard perforations upon request. Suitable for fitting **both horizontally and vertically**, the adjustable system affords maximum privacy while maintaining the view towards the outside, whatever the project.

- Large perforated wing-shaped blade (500 mm and 600 mm)
- The optimum balance between sunlight and shade control
- Adjustable system

Basic components

→ Sun control blades

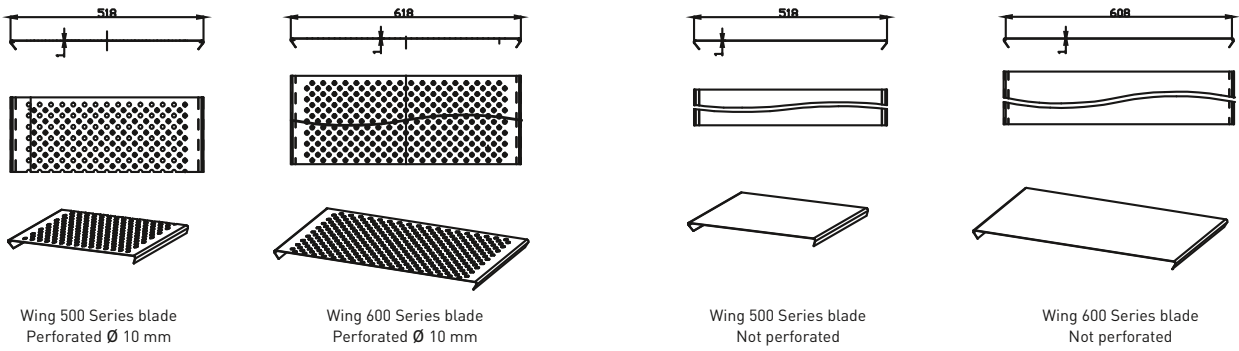

→ Support profiles

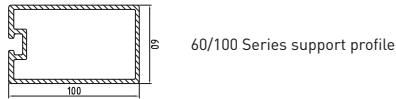

→ Blade holders

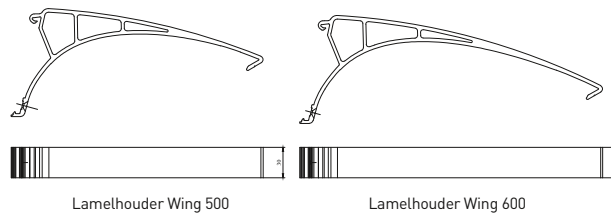

System

→ DucoSun Wing Adjustable

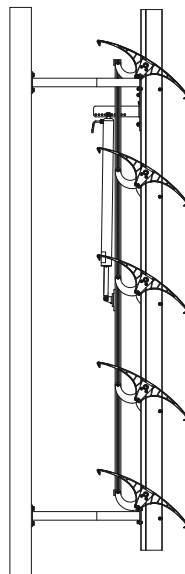

Maximum span of intermediate systems

→ DucoSun Ellips intermediate

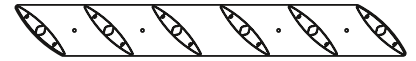

→ DucoSun Linear intermediate



→ DucoSun Cubic intermediate

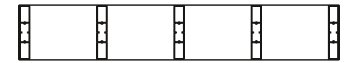

Situation #1 : Fitting a blade between two bespoke assembly plates (Please see www.duco.eu for full details of maximum sizes.)

Situation #2 : Fitting a blade between two Duco end caps between a fixed structure

Situation #3 : Fitting a blade between two Duco end caps and support profile between a fixed structure

DucoSun Ellips

			With a wind load of :					
Ellips series blade	Blade mounting angle	Ymin. distance (mm) (maximum fixing centres)	600 Pa (±115 km/h)		800 Pa (±130km/h)		1,250 Pa (±165km/h)	
100	0°	40	3300	3300	3300	3300	2800	2800
	45°	50	3300	3300	3300	3300	2800	2800
150	0°	60	4000	4000	4000	3600	3400	2900
	45°	80	4000	4000	4000	4000	3400	3400
200	0°	70	4100	3800	4100	3300	3700	2700
	45°	80	4100	4100	4100	4000	3700	3300
250	0°	110	4400	4200	4400	3700	4000	3000
	45°	110	4400	4200	4400	3700	4000	3000
300	0°	100	4700	3600	4700	3200	4500	2600
	45°	140	4700	4300	4700	3800	4500	3100
350	0°	132	5000	4100	5000	3600	5000	3200
	45°	132	5000	4100	5000	3600	5000	3200
400	0°	100	5200	3300	5000	2900	4000	2400
	45°	132	5200	3800	5200	3400	4800	2800

DucoSun Cubic

			With a wind load of:					
Cubic series blade	Blade mounting angle	Ymin. distance (mm) (maximum fixing centres)	600 Pa (±115 km/h)		800 Pa (±130km/h)		1,250 Pa (±165km/h)	
150	0°	69	3650	3650	3650	3650	3650	3600
	45°	109	3650	3650	3650	3650	3650	3600
200	0°	70	4100	4100	4100	3700	4100	3000
	45°	98	4100	4100	4100	4100	4100	3600
300	0°	90	4700	3900	4700	3400	3900	2800
	45°	110	4700	4300	4700	3800	4400	3100
400	0°	130	5200	3900	5200	3500	4400	3100
	45°	150	5200	3800	5200	3800	4700	3100

DucoSun Linear

			With a wind load of:					
Linear Series blade	Blade mounting angle	Ymin. distance (mm) (maximum fixing centres)	600 Pa (±115 km/h)		800 Pa (±130km/h)		1,250 Pa (±165km/h)	
200	0°	70	4100	4200	4100	3800	4100	3100
	45°	80	4100	4100	4100	4000	4100	3300
300	0°	80	4500	3700	4500	3200	3700	2600
	45°	130	4500	4500	4500	4100	4300	3400

Maximum span of adjustable systems

→ DucoSun Ellips adjustable

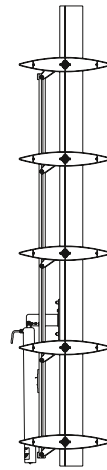

→ DucoSun Cubic adjustable

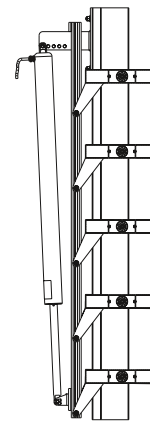

→ DucoSun Linear adjustable

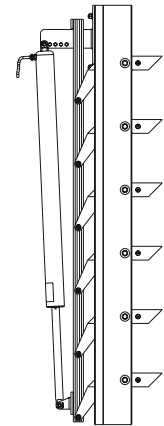

DucoSun Ellips

Blade Ellips	With a wind load of:		
	600 Pa (±115 km/h)	800 Pa (±130km/h)	1,250 Pa (±165km/h)
100	2200	2000	1800
150	2500	2200	2000
200	2600	2400	2100
250	3300	3100	2700
300	3300	3000	2600
350	3700	3400	3000
400	4000	3700	3200

DucoSun Cubic

Blade Cubic	With a wind load of:		
	600 Pa (±115 km/h)	800 Pa (±130km/h)	1,250 Pa (±165km/h)
150	3000	2800	2400
200	3400	3200	2800
300	3400	3200	2900
400	4100	3900	3500

DucoSun Linear

Blade Linear	With a wind load of:		
	600 Pa (±115 km/h)	800 Pa (±130km/h)	1,250 Pa (±165km/h)
200	3200	3000	2700
300	3400	3200	2800

DucoSun Wing

Blade Wing	With a wind load of:		
	600 Pa (±115 km/h)	800 Pa (±130km/h)	1,250 Pa (±165km/h)
500	4750	4400	3960
600	4550	4250	3800



Maximum span of Unifit systems

→ DucoSun Ellips Unifit

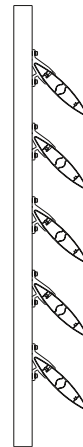

→ DucoSun Cubic Unifit

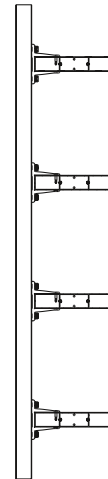

→ DucoSun Linear Unifit

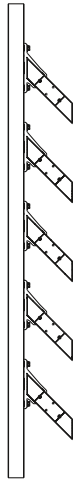

Permanent external sun control system. The aluminium sun control blades are fitted to aluminium support profiles at a fixed blade mounting angle of 0° or 45° using Unifit clamp fixing brackets. The amount of clearance between two sun control blades (blade pitch) depends on blade type and blade mounting angle.

DucoSun Ellips

Blade Ellips	Unifit :		With a wind load of:		
	fork(°)	width (mm)	600 Pa (±115 km/h)	800 Pa (±130km/h)	1,250 Pa (±165km/h)
100	0°	40	3000	2850	2575
150	0°	40	3200	3200	3000
	45°	40	3200	3200	3000
200	0°	40	3400	3400	3200
	45°	40	3400	3400	3200
250	0°	40	3700	3700	3100
	45°	40	3700	3700	3500
300	0°	40	3900	3200	2100
350	45°	60	4900	4400	2800

DucoSun Cubic

Blade Cubic	Unifit :		With a wind load of:		
	fork(°)	width (mm)	600 Pa (±115 km/h)	800 Pa (±130km/h)	1,250 Pa (±165km/h)
150	0°	40	3075	3075	3075
200	0°	40	3400	3400	3400
300	0°	40	3900	3300	3200

DucoSun Linear

Blade Linear	Unifit :		With a wind load of:		
	fork(°)	width (mm)	600 Pa (±115 km/h)	800 Pa (±130km/h)	1,250 Pa (±165km/h)
200	45°	40	3400	3400	3400
300	45°	40	3900	3900	2700

Maximum span of Multifit systems

→ DucoSun Ellips Multifit

→ DucoSun Cubic Multifit

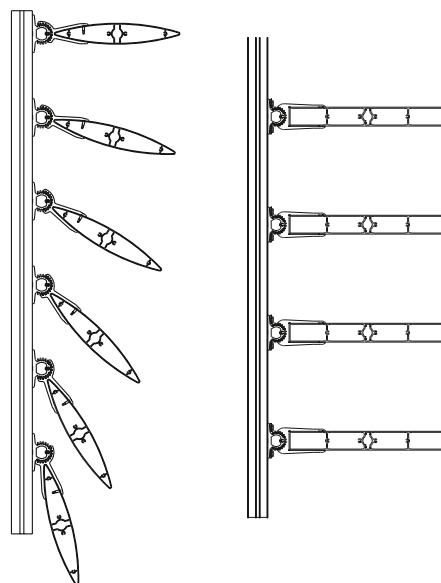

Permanent external sun control system. The aluminium sun control blades are fitted to aluminium support profiles at a **fixed blade mounting angle** using the patented Multifit system. This system consists of a “base” and a “clamp fixing bracket”. These two parts are linked together with prongs. This means that various positions in **15° increments** are possible. The amount of clearance between two sun control blades (blade pitch) depends on blade type and blade mounting angle.

DucoSun Ellips

		With a wind load of:		
Ellips series blade	Multifit width (mm)	600 Pa (±115 km/h)	800 Pa (±130km/h)	1,250 Pa (±165km/h)
200	60/40	3500	2800	1800
	60/80	3500	3500	3500
250	60/40	2400	1850	1250
	60/80	3600	3600	2500
250	80/40	3600	2775	1850
	80/80	3850	3850	3600
	80/120	3850	3850	3850
300	80/40	2500	1900	1300
	80/80	3900	3900	2600
	80/120	4000	4000	4000
350	80/40	-	-	-
	80/80	3700	2900	1900
	80/120	4200	4200	2900
400	80/40	-	-	-
	80/80	2900	2200	1500
	80/120	4300	3400	2300

DucoSun Cubic

		With a wind load of:		
Cubic series blade	Multifit width (mm)	600 Pa (±115 km/h)	800 Pa (±130 km/h)	1,250 Pa (±165km/h)
400	50	2380	1905	1310
	80	4049	3468	2390
	120	4337	3468	2390





COMPLETED PROJECT

HOME OF OXYGEN



DucoSlide

Aluminium sliding panels

Duco has also developed architectural sun control using sliding panels. The DucoSlide range consists of aluminium frames that hold wooden or aluminium blades. The architect or future owner always has an extensive choice of blades to match the requirements of any individual project. These frames can, moreover, be slid both manually or electronically.

The aluminium frames can be slid fully in front of the windows using a rail for achieving an optimum balance between sun control and light entry. Thanks to the different sliding systems available – single, symmetrical, telescopic or bifold – the panels can also be slid fully away from the window.

→ Types

1. DucoSlide LuxFrame

External sun control systems that have their aluminium blades fitted within a frame. There are two different types available:

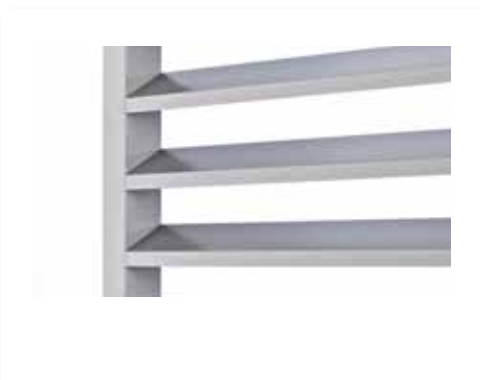

2. DucoSlide SlimFrame

External sun control systems of which the aluminium fins are fixed between discreet lateral guide rails.



→ Material

→ Aluminium: EN AW – 6060 T66

→ Surface treatment:

Standard natural anodised finish (15-20 µm) (VB6/A20/VOM1).

Stove enamelled and polyester powder coated (60-80 µm)

Wood grain finish: further information on request.

→ Some types are also available with timber blades.

→ Operating Control

All DucoSlide types covered in this brochure can be operated manually or electrically (except for the Bifold type). Contact Duco for more complete details.



DucoSlide LuxFrame

The DucoSlide LuxFrame is a permanent external sun control system with sliding panels. In this type, the different blades are fitted in a heavy-duty framework profile.

Types :

- DucoSlide LuxFrame with a 40/40 framing system and fixed blades
- DucoSlide LuxFrame with a 40/80 framing system and fixed or adjustable blades

→ Maximum amount of privacy.

→ Single, double or telescopic sliding system.

→ Choice of fixed or adjustable blades.

→ Different blade sizes.

→ Can be operated manually or electrically.

→ Available in aluminium and wooden blades.

Blade types



	Linear 55 Series	Lux 40 Wood	40Z	60F	Perfo	Lux 80 Wood	Linear 115* Series
LuxFrame 40/40	X	X	X	X	X		
LuxFrame 40/80						X	X
Blade height (mm)	55	53	85	51	-	65	115
Blade pitch (mm)	70	70	110	80	-	100	145
Blade slope	33°	53°	48°	55°	-	37°	39°

* This version is also available with movable blades.
For more information: visit our website or contact Duco.

Cross-sectional drawings

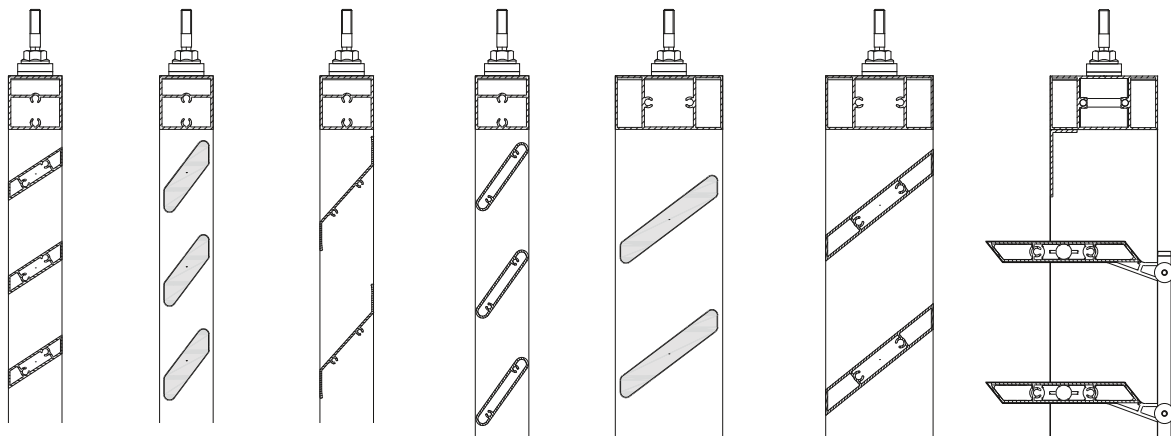

Linear 55

Lux 40 Wood

40Z

60F

Lux 80 Wood

Linear 115

Linear 115 adjustable

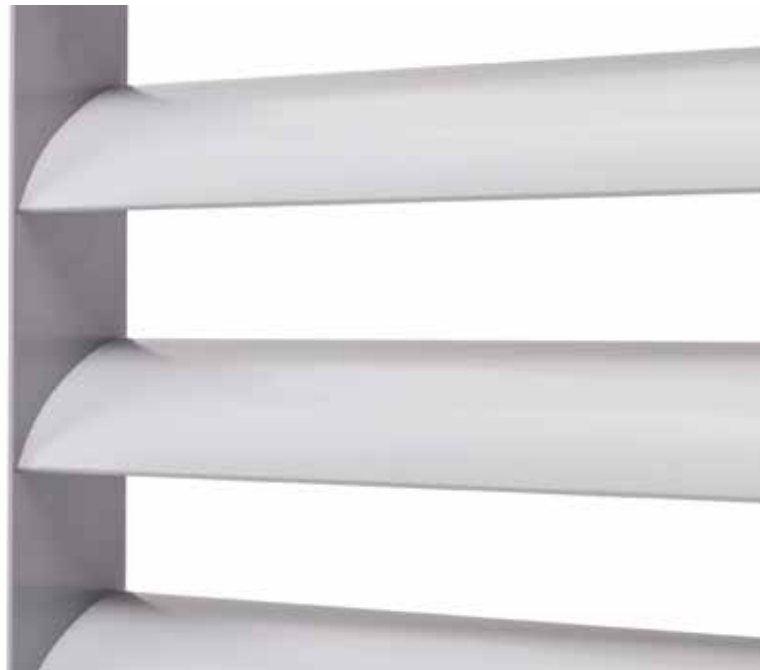

DucoSlide SlimFrame

The DucoSlide SlimFrame is a permanent external sun control system with sliding panels. The blades are mounted at a fixed blade mounting angle between the refined and discrete lateral guide rails in this type.

Types :

- DucoSlide SlimFrame with a 5/50 framing system and fixed blades
- DucoSlide SlimFrame with a 5/80 framing system and fixed blades

- Maximum amount of privacy.
- Single, symmetrical, bifold or telescopic sliding system.
- Different blade sizes.
- Can be operated manually or electrically.

* Only possible for DucoSlide SlimFrame 5/80

Blade types



	50Z/30°	60F	100D	Ellips 100
SlimFrame 5/50	X	X		
SlimFrame 5/80			X	X
Blade height (mm)	72	72	100	100
Blade pitch (mm)	115	70	140	140
Blade slope	30°	40°	45°	45°

* The blade mounting angle is 42.4° with regard to the Bifold sliding system.

Cross-sectional drawings

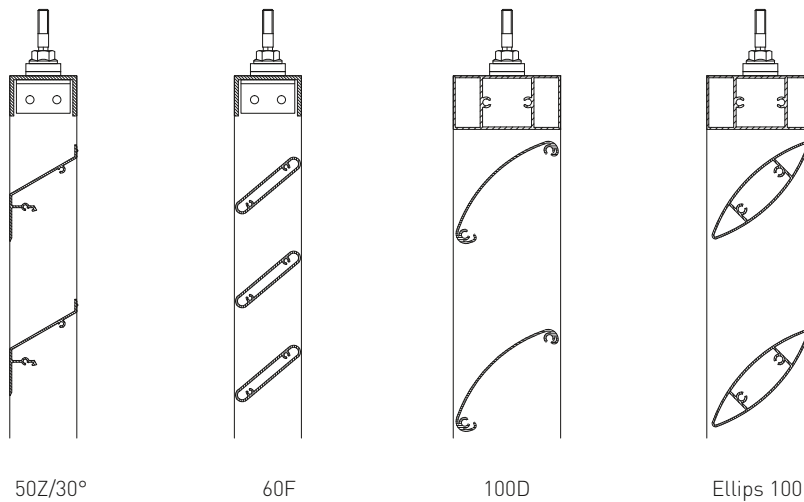

HOME OF OXYGEN





Types of Sliding Systems

→ Single sliding system

Individually operable independent shutter panels.

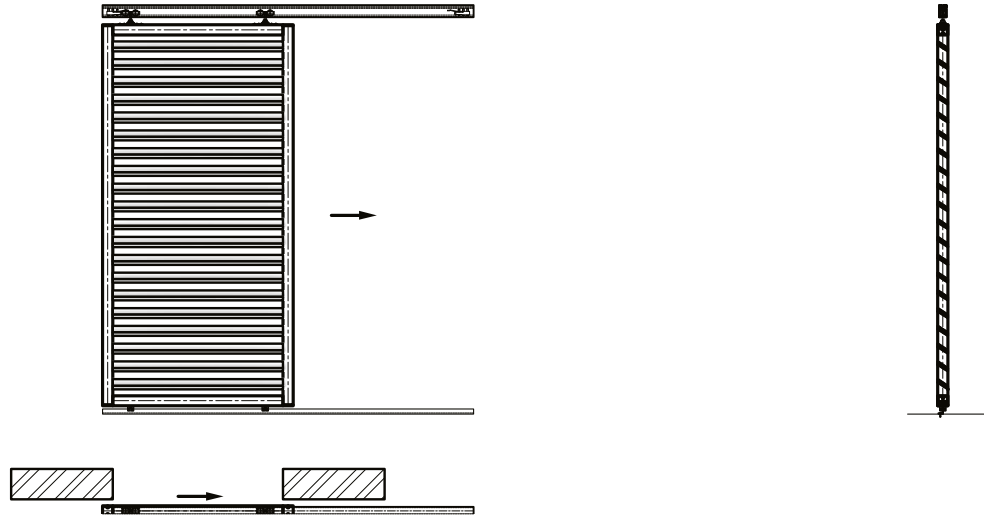

→ Symmetrical sliding system

Two shutter panels joined to each other that move towards each other or move away from each other in a symmetrical fashion.

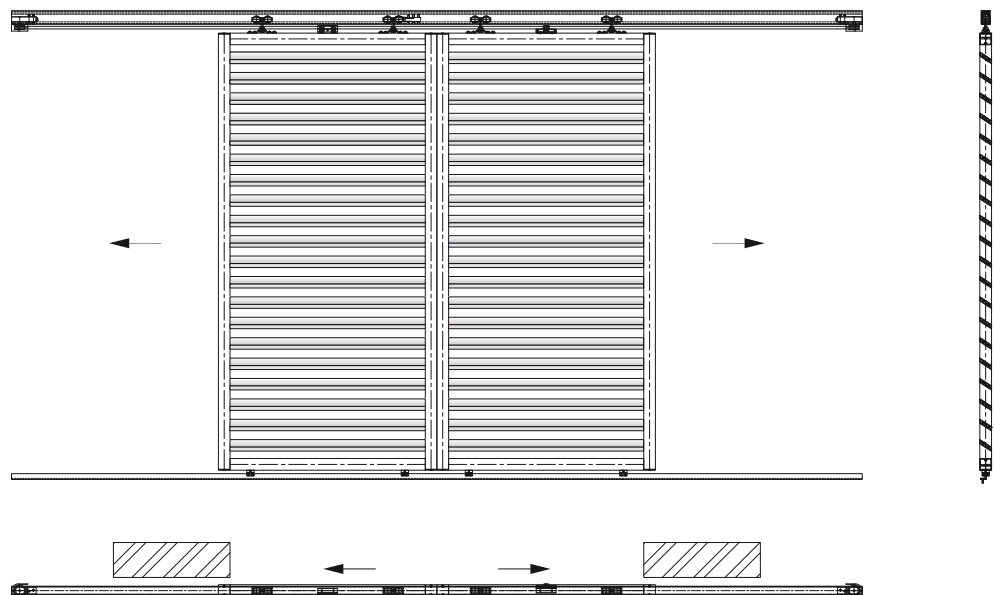

→ Telescopic sliding system

Two or three parallel shutter panels joined to each other that slide in a telescopic manner.

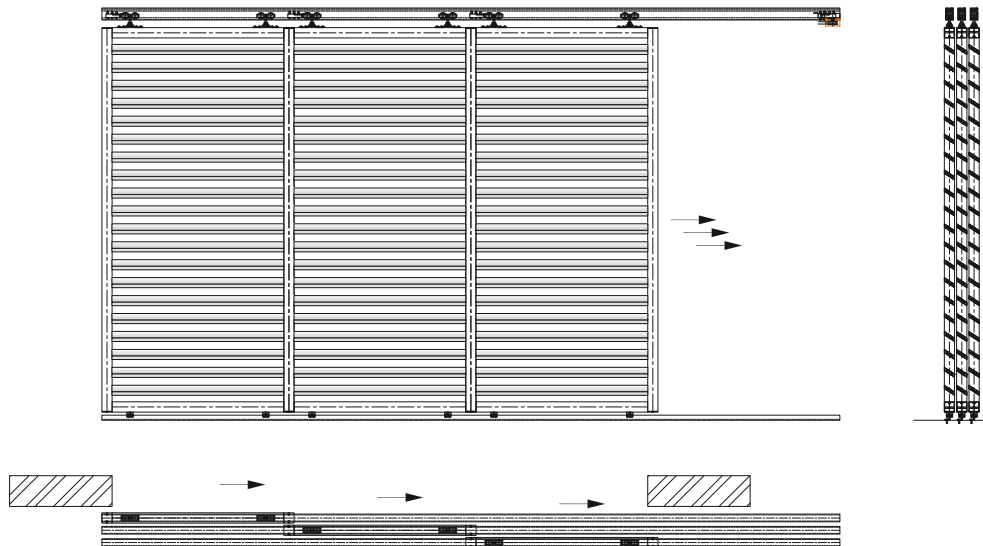

→ Bifold sliding system*

Two folding panels with a fixed frame that can be slid fully to one side. This creates a different design when in the open or closed position.

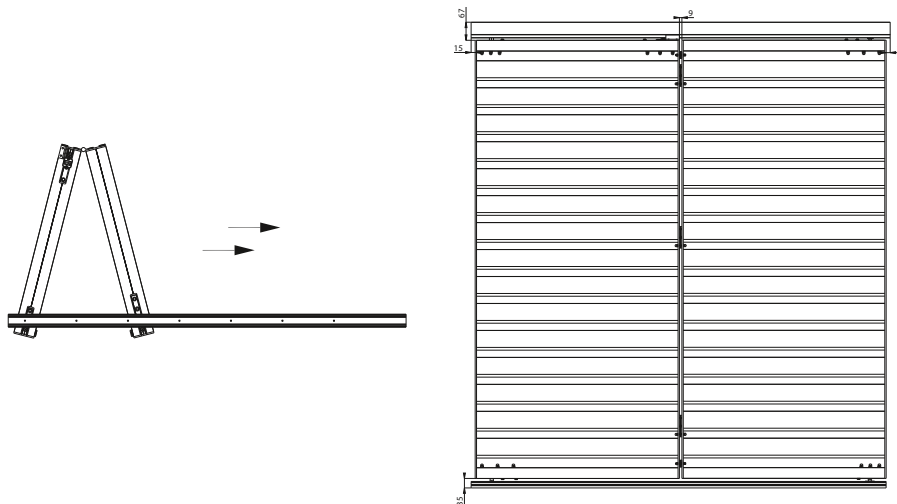

* enkel mogelijk bij DucoSlide Slimframe 5/80 met lamel 100D

→ Dimensions

The maximum dimensions of the frame of DucoSlide sliding shutters are type- and project-specific. Contact Duco for determining the dimensions of your project.

HOME OF OXYGEN







DUCO
Ventilation & Sun Control

Bedrijvenlaan 2 - B-8630 Veurne - Belgium - tel +32 58 33 00 66 - fax +32 58 33 00 67 - info@duco.eu - www.duco.eu

01.06.2014-1: Subject to printing errors and/or changes.