

READ AND SAVE THESE INSTRUCTIONS

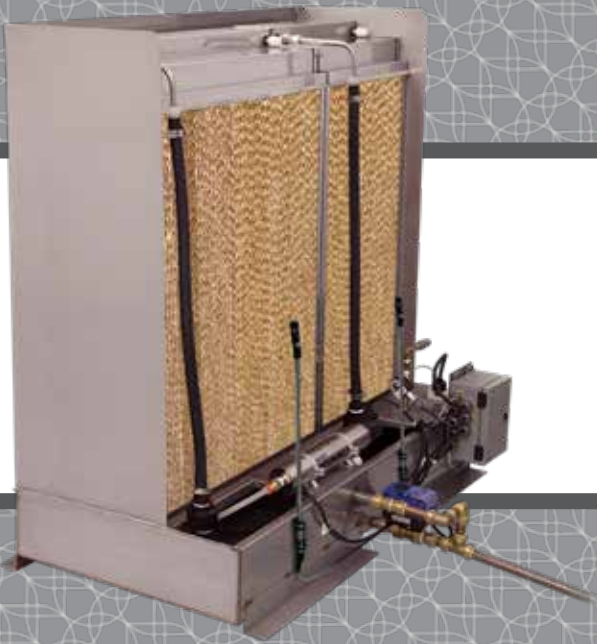

EVAPORATIVE COOLING AND HUMIDIFICATION







Wetted Media System
with Vapor-Logic® control

Installation, Operation,
and Maintenance Manual

Warnings and cautions

 WARNING	CAUTION
<p>Indicates a hazardous situation that could result in death or serious injury if instructions are not followed.</p>	<p>Indicates a hazardous situation that could result in damage to or destruction of property if instructions are not followed.</p>

mc_051508_1145

 INSTALLATION AND MAINTENANCE WARNINGS	
	<p>Attention installer Read this manual before installing, and leave this manual with product owner. This product must be installed by qualified HVAC and electrical contractors. Installation must be code approved.</p>
 	<p>Disconnect electrical power Disconnect electrical power before installing supply wiring or performing service or maintenance procedures on any part of system. Failure to disconnect electrical power could result in fire, electrical shock, and other hazardous conditions. These hazardous conditions could cause property damage, personal injury, or death.</p>
	<p>Monitor for leaks or drips Monitor duct or air handling unit (AHU) for leaks or drips in and near area where Wetted Media System is installed. Uncorrected leaks or drips could cause wet floors and slippery footing, which could lead to personal injury. Leaks or drips above equipment could cause property damage.</p>
	<p>Preventing bacteria and mold growth Wetted Media System automatically initiates dry-out cycles to prevent bacteria and mold growth, which can cause illness. Allow system to complete all dry-out cycles, and maintain tank and media as recommended.</p>

 UV SYSTEM WARNINGS
<p>UV exposure: Do not illuminate UV lamp outside of UV Chamber. Always use protective gear, including gloves and UV safety glasses. Never look directly at illuminated UV Lamp, even when using protective gear. If accidental exposure occurs, immediately cool affected area and consult physician.</p>
<p>Impalement: Do not inspect, repair, or maintain quartz sleeve until UV chamber has been isolated and depressurized.</p>
<p>Hot UV chamber: Allow UV lamps and UV chamber to cool for a minimum of 10 minutes before handling.</p>
<p>Cut or ingestion: Ensure that quartz sleeve and UV lamp are not broken, cracked, or damaged before handling them.</p>
<p>Scald from hot water: When there is no water flow, water in UV chamber will become hot. To prevent scalding, allow system to cool before draining system.</p>
<p>Fire: Do not store combustible or flammable material close to the system.</p>
<p>Mercury exposure: UV lamp contains mercury. If lamp breaks, avoid inhaling or ingesting debris, and avoid exposure to eyes and skin. Do not use a vacuum cleaner to clean up broken lamp; this could scatter spilled mercury. Obey local regulations and guidelines for removal and disposal of mercury waste.</p>
<p>Water leak: Use only recommended UV assembly plumbing materials and fittings to avoid potential material degradation from UV exposure.</p>

Warnings and cautions

CAUTION

Operate system at above-freezing temperatures

Operating the system at temperatures below freezing can cause damage to the system or other property damage.

Maintain pump and supply water

Inadequately maintained supply water can cause the system to fail. Refer to the maintenance section (beginning on page 31) for recommendations.

Prevent water drops in airstream

To prevent water drops from becoming entrained in the airstream:

- Maintain the media as recommended.
- Do not exceed the maximum recommended air velocity in the duct or AHU.

Follow all instructions in this manual to maintain product warranty.

Table of contents

Warnings and cautions	ii
Overview	4
Components	4
Specifications	5
Installation	7
Installation locations	7
Field piping	9
Supply water piping	9
Drain piping	9
Assembling tank and frame	10
Typical tools and accessories needed	10
Sequence of assembly	10
Wiring	14
Wiring diagrams	14
Control cabinet and field wiring	14
Control input devices	14
Electrical installation	15
Service disconnect	15
Grounding requirements	15
Preventing electrical noise	16
Control wiring	16
Cycles of concentration	17
Water from other sources	19
Example conditions	19
Example calculations	19

ATTENTION INSTALLER

Read this manual before installing.
Leave manual with product owner.

DriSteem® Corporation Technical Support

North America: 800-328-4447
Europe: +3211823595

WHERE TO FIND MORE INFORMATION

Our website:

The following documents are available on our web site: www.dristeem.com

- Evaporative Cooling and Humidification Catalog
- Vapor-logic Controller Installation and Operation Manual

Call us at 800-328-4447

Obtaining documents from our web site or from DriCalc is the quickest way to view our literature, or we will be happy to mail literature to you.

Table of contents

Operation	20
Start-up checklist	20
Test run	20
Test outputs	20
Keypad/display	21
Changing mode and set point	22
Changing other parameters	22
Activity definitions	22
Connecting to the network	22
Web interface communication	22
Status screen	23
Diagnostics and Alarms	24
Modbus, BACnet, LonTalk interoperability	25
Controller-initiated media care	30
Cycles of concentration	30
Dry-out cycling	30
Maintenance	31
Media	31
Pumps	32
UV lamp replacement	33
UV assembly quartz sleeve replacement	34
Tank and probe	35
Interval maintenance	36
Replacement parts	37
Troubleshooting	40
Warranty	44

Keypad/display and troubleshooting

The *Vapor-logic Controller Installation and Operation Manual*, which was shipped with your system, is a comprehensive operation manual. Refer to it for information about using the keypad/display and Web interface, and for troubleshooting information.

Download DriSteem literature

Most DriSteem product manuals are available on our website: www.dristeem.com

Components

FIGURE 4-1: DRISTEEM WETTED MEDIA SYSTEM OVERVIEW

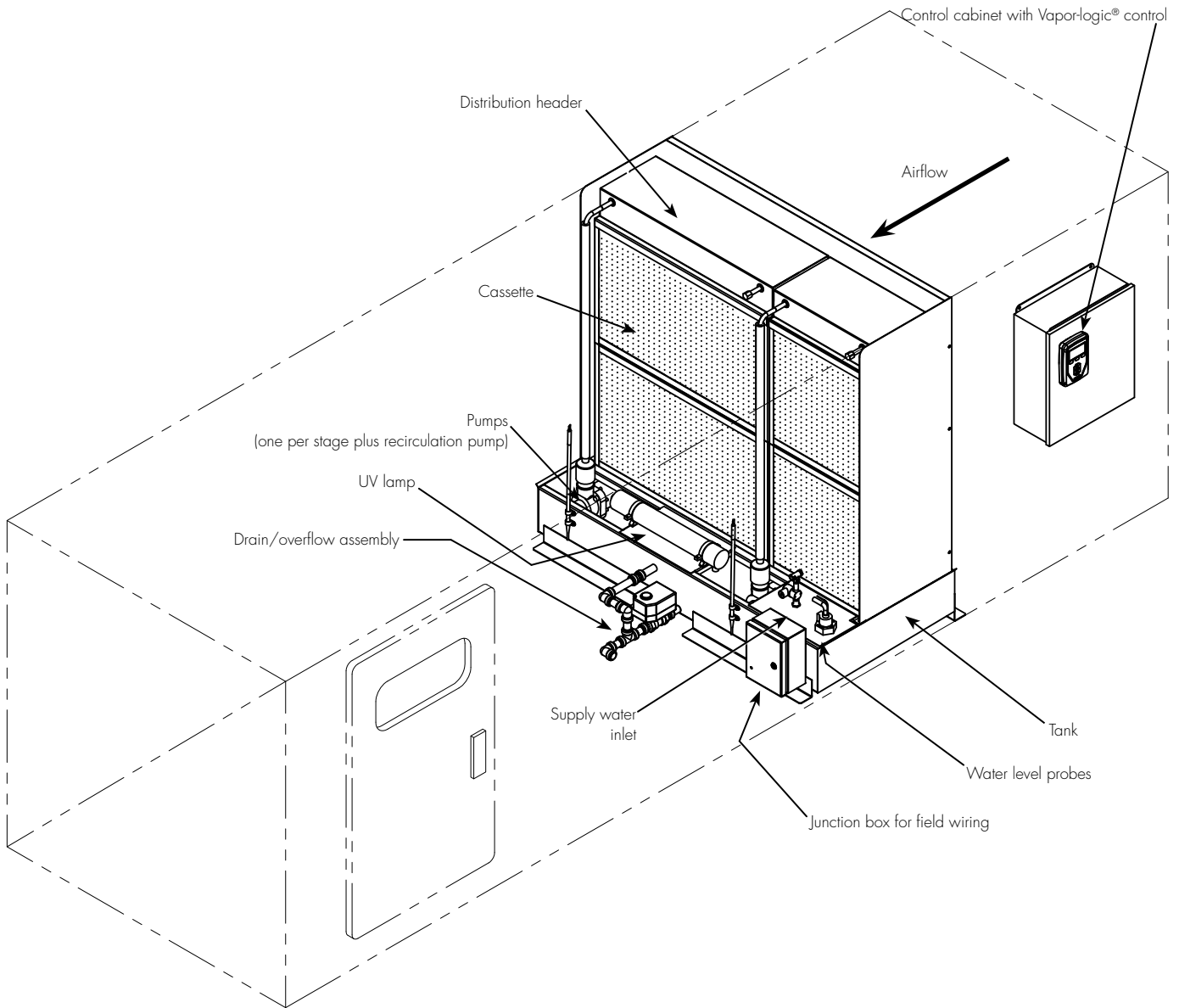

Note: System components and configuration may vary to meet application requirements.

OM-7792a

Specifications

Table 5-1: Wetted Media System specifications	
Item	Specification
System capacity	Varies with application. See graph on page 6 for system efficiencies and to calculate system capacity.
System voltage/phase/Amp draw*	120 Volts, Max 7 Amps, 1 phase, 60 Hz 230 Volts, Max 15 Amps, 1 phase, 50 Hz
Fuse size**	120 Volts, 1 phase, 60 Hz: 10 Amps 230 Volts, 1 phase, 50 Hz: 20 Amps
Height	30" to 120" (762 mm to 3048 mm)
Width	24" to 120" (610 mm to 3048 mm)
Depth	34.5" (876 mm)
Operating weight***	System operating weight = tank operating weight + media operating weight Pounds = 65 lbs/ft of width + 20 lbs/ft ² Kilograms = 98 kg/m of width + 30 kg/m ²
Shipping weight***	System shipping weight = tank shipping weight + media shipping weight Pounds = 30 lbs/ft of width + 10 lbs/ft ² Kilograms = 45 kg/m of width + 15 kg/m ²
Supply water pressure	25 to 80 psi (170 to 550) kPa
Supply water connection, diameter	3/8" to 3/4", (DN10 to DN20) depending on flow rate
Drain connection, diameter	1" (DN25), copper
Recommended inlet water flow rate	3x system capacity or 11 gpm (42 L/m) max.
Air velocity, maximum recommended	700 fpm (3.5 m/s) through wetted media without droplet separator 900 fpm [4.6 m/s] with droplet separator
Water quality requirements	System recycle rate depends on water quality. Contact DriSteem for more information.
<p>* Cataloged amperages assume one pump per stage. Some large systems may require additional pumps depending on operating conditions. Contact DriSteem for system amperages.</p> <p>** Wiring and branch circuit protection (Type RK1, J, or T fusing) to be provided by installer in accordance with National Electrical Code (NEC) requirements or (in Europe) IEC 60364 requirements.</p> <p>*** System weight calculation examples</p> <p>Operating weight in <i>pounds</i> for a 6-ft-high x 8-ft-wide Wetted Media System): = (65 lbs/ft) x (8 ft wide) + (20 lbs/ft²) x (8 ft wide) x (6 ft high – 1 ft tank height) = 520 lbs + 800 lbs = 1320 lbs</p> <p>Operating weight in <i>kilograms</i> for a 2-meter-high x 3-meter-wide Wetted Media System): = (98 kg/m) x (2 m wide) + (30 kg/m²) x (3 m wide) x (2 m high – 0.3 m tank height) = 196 kg + 153 kg = 349 kg</p>	

Specifications

FIGURE 6-1: WETTED MEDIA SYSTEM COOLING EFFICIENCY AND PRESSURE DROP

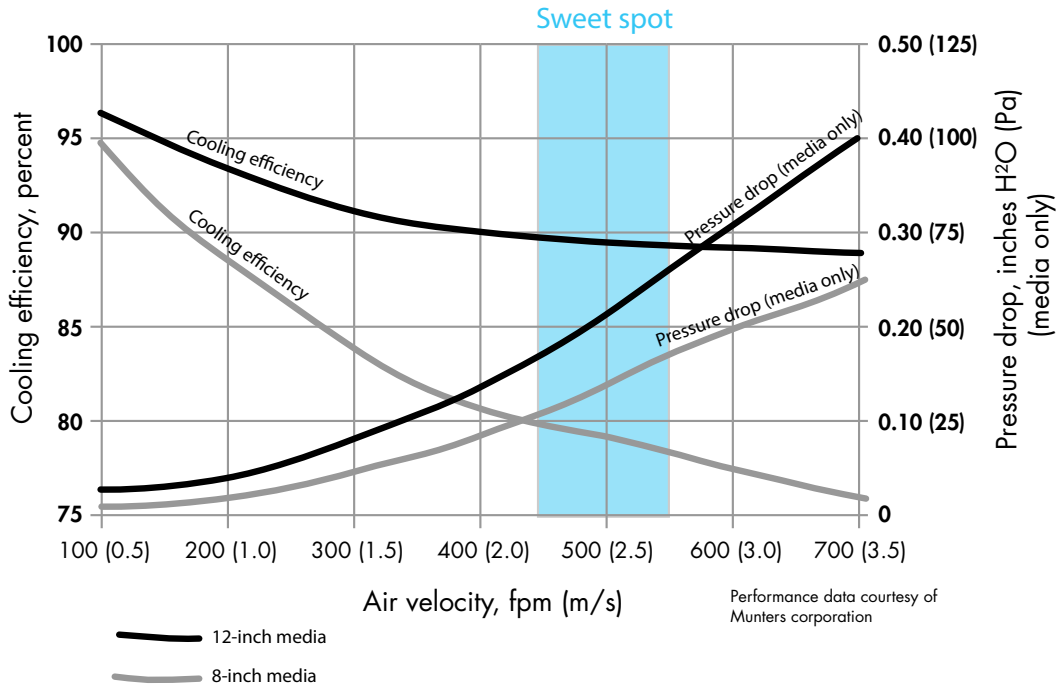
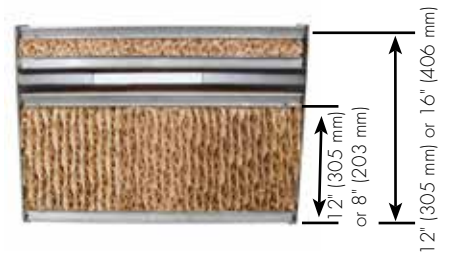
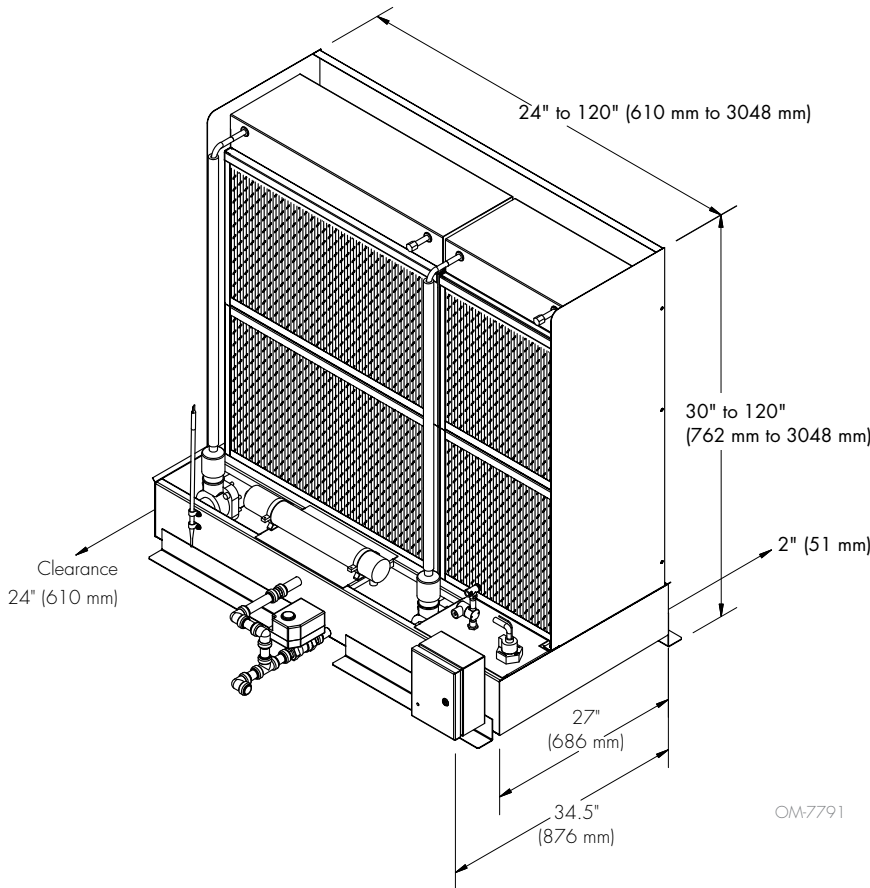

FIGURE 6-2: DRISTEEM WETTED MEDIA SYSTEM DIMENSIONS AND CLEARANCES

FIGURE 6-3: MEDIA THICKNESS



Installation locations

WETTED MEDIA SYSTEM

Consider the following when selecting the installation location for the Wetted Media System:

- Ability of duct/AHU to support the maximum operating weight of the system. See **Operating weight** in Table 5-1 and warning at right.
- Easy access for maintenance. Provide at least 24" (610 mm) downstream for operator to repair the equipment. No additional space requirements are needed upstream from the wetted media system.
- Maximum ambient temperature is 104 °F (40 °C).
- Clearance recommendations (see Figure 6-2).
- Electrical connections: Power, control, and safety circuits
- Plumbing connections: Supply water and drain piping (see "Field piping overview" on page 9).
- Avoid locations above critical equipment or processes.
- Avoid locations close to sources of electromagnetic emissions, such as power distribution transformers and high horsepower motors controlled by variable frequency drives.
- Air velocities should be from 100 to 900 fpm (0.5 to 4.6 m/s). Droplet separation required for speeds greater than 700 fpm (3.5 m/s).

Important:

Installation must comply with governing codes.

WARNING

Duct/AHU must support system weight
Install the system in a structurally stable duct or AHU. Installing the system where the duct/AHU cannot support the system can cause it to fall, resulting in severe personal injury or death.

Installation locations

CONTROL CABINETS

A ground wire is necessary from the machine ground lug in the control cabinet to earth ground. The bonding machine ground wire should be sized per National Electrical Code (NEC) or IEC 60364 requirements.

SENSORS

- Provide at least 24" (610 mm) in front of the sensors to allow the operator to repair the equipment.
- Select locations where there is minimal mechanical or environmental risk of damage to the sensors.
- For AHU applications:
 - Position the RH sensor in the return air section where the air conditions are most similar to the space conditions being controlled.
 - Position the air flow switch at least 3' (1 m) upstream of and in the same airstream as the Wetted Media System.

Field piping

SUPPLY WATER PIPING

Required inlet pressure range is 25 to 80 psi (170 to 550 kPa). Minimum inlet dynamic (while running) pressure is 25 psi (170 kPa).

DriSteem recommends installing the following (supplied by others) in the supply water line:

- Manual shut-off valve
- Water pressure gauge rated to 120 psi (830 kPa)

DRAIN PIPING

The Wetted Media System drain connection is a push-to-connect fitting.

- Run the drain piping (supplied by others) from the Wetted Media System to the AHU or duct drain.
- Do not reduce the diameter of the drain line downstream from the drain connection.
- DriSteem recommends copper drain piping.

Assembling tank and frame

Choose the installation location (see “Installation locations” on page 7) in the duct or AHU, and assemble the system in place. See Figure 12-1 for components and fastening hardware included with the system. After unpacking the system, verify that all packing list items are included in shipment.

TYPICAL TOOLS AND ACCESSORIES NEEDED

Depending on system configuration, some items listed might not be required.

- Wrenches and nut driver or power driver for fastening hardware
- Adjustable wrench for pipe fittings
- Screwdrivers for power connections and cabinet access
- Precision screwdrivers for signal connections
- Pipe fittings, reducing fittings, and supply water and drain piping
- Teflon-tape
- Pipe supports/hangers

SEQUENCE OF ASSEMBLY

To avoid wasting time undoing connections, assemble the components in the order described below.

Note: Step numbers correspond to numbered callouts in Figure 12-1 and Figure 13-1.

1. Place tank assembly on duct/AHU floor with overflow/drain facing downstream. Make sure tank is level from left to right and from front to back.

Note: If the duct/AHU floor is not level, insert shims under the tank support feet to level the tank. A level/plumb system is important for proper tank draining and for the even distribution of water across the media.
2. Attach side braces to side panels, then to tank. Attach additional blank-off material to the side panel from ceiling to floor for increased efficiency of your system.

Note: Carefully orient the bracing parts as shown.
3. Attach frame support to tops of bracing members. Attach additional blank-off to the top panel for increased efficiency of your system.
4. Attach center braces (only used on larger systems) to tank and to frame support.

FIGURE 10-1: BLANK OFF OPEN SPACE

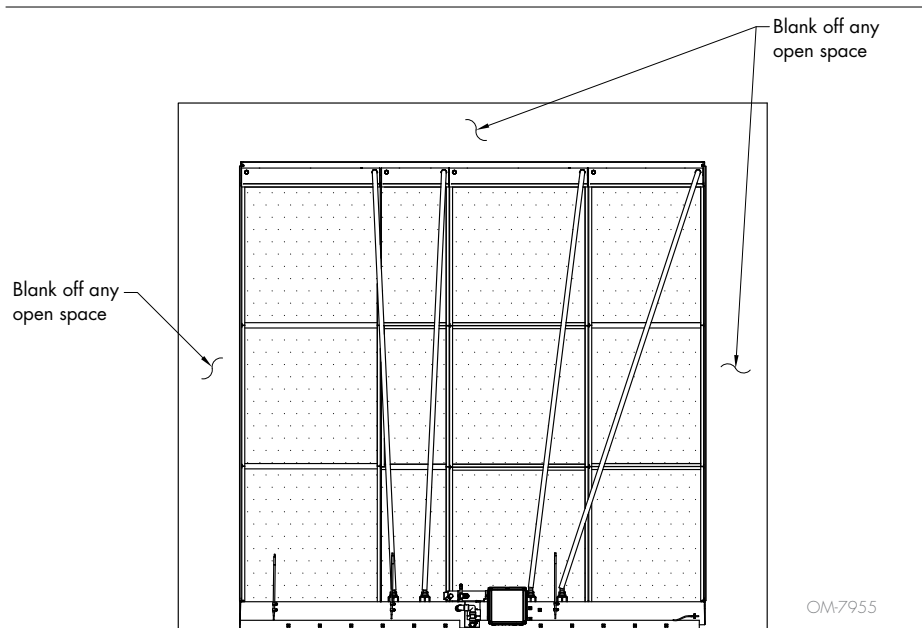

Assembling tank and frame

5. Confirm baffle plate is positioned with baffles angled down and directing drainage upstream.
6. Place media cassettes inside of frame.
Note: Tabs on the media cassette frames ensure proper orientation. To ensure maximum performance and media life, do not try forcing the media cassettes into their slots if the tabs conflict with the frame or with each other.
7. Attach distribution header(s) on top of frame with the inlets facing downstream.
8. Attach pump hoses to distribution header inlets and pumps, and tighten hose clamps.
Note: The hoses should not cross or loop as they run from pump to hood.
9. Leaving the temperature sensors in the present position, rotate and secure to the tank vertically.
10. Install drain/overflow assembly to welded tank connections.
11. Install drain line (by others) from Wetted Media System drain tee to building drain. See "Drain piping" on page 9.
Note: During a power failure, the Wetted Media system will automatically drain the water from the system.
12. Install water line (by others) from municipal water supply or water softener to Wetted Media System supply water inlet. See "Supply water piping" on page 9.
13. Mount control cabinet outside of duct/AHU. See "Control cabinet" on page 14 instructions on wiring to junction box.
14. Securely attach the system to the air handler, walls, and/or ceiling.

Assembling tank and frame

FIGURE 12-1: WETTED MEDIA SYSTEM ASSEMBLY DRAWING

2-stage system shown

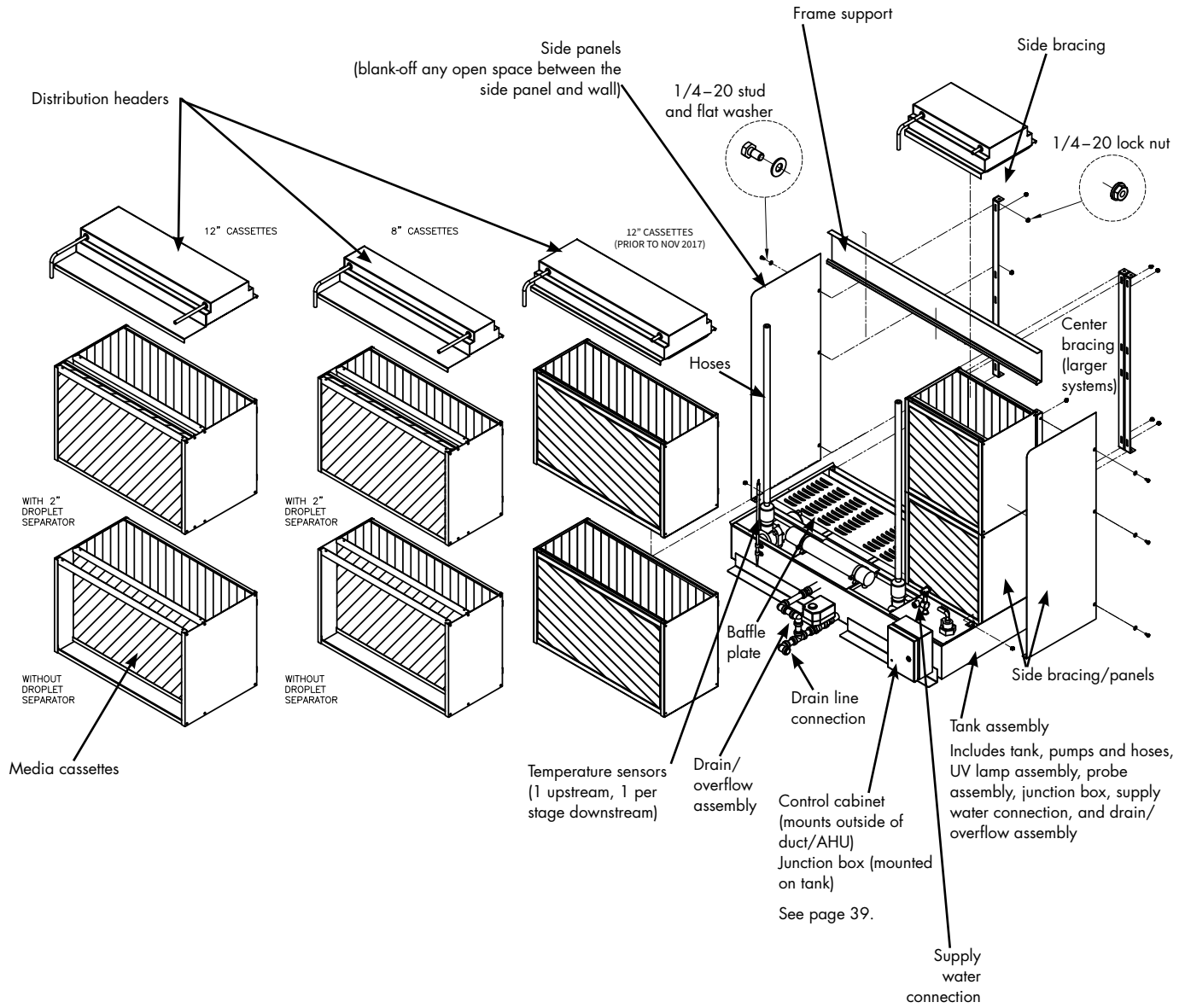

Note: Droplet separation (not shown) is recommended for air velocities above 700 fpm (3.5 m/s)

OM-7795_aa

Assembling tank and frame

FIGURE 13-1: WETTED MEDIA SYSTEM ASSEMBLY DRAWING

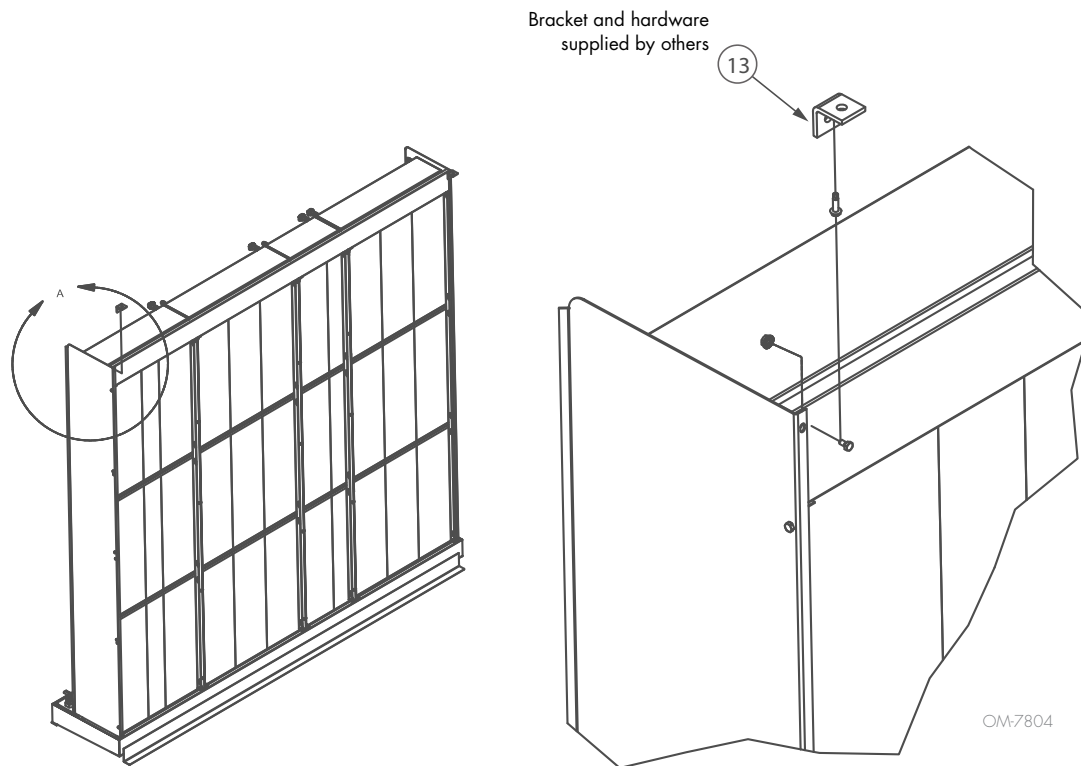

Wiring

WIRING DIAGRAMS

The following wiring diagrams are included with the Wetted Media System separate from this manual:

- Ladder style wiring diagrams show power, control, and equipment-to-control-cabinet interconnection requirements.
- External connections diagrams show connection points to the Vapor-logic controller and wire terminals for external safety and control devices, airflow proving switches, transmitters, or humidistats.

All wiring must be in accordance with governing codes and wiring diagrams.

CONTROL CABINET AND FIELD WIRING

- Locate the wiring diagrams referenced in the note at left.
- The length of wire from the control cabinet to the Wetted Media System must not exceed 50' (15 m).
- Terminals for field connections are labeled in the Vapor-logic control cabinet and in the junction box mounted on the Wetted Media System tank.
- All wiring can be run in a single conduit. Waterproof conduit is required.
- See pages 15 and 16 for detailed wiring recommendations.

CONTROL INPUT DEVICES

Refer to wiring diagrams supplied with the system and the Vapor-logic Controller Installation and Operation Manual for wiring requirements and connection points.

AHU applications:

- Position the air flow switch at least 3' (1 m) upstream of and in the same airstream as the Wetted Media System.
- See page 8 for control sensor installation recommendations.
- Wire control devices to control cabinet as indicated for this system.

Wiring

ELECTRICAL INSTALLATION

Wiring and branch circuit protection is provided by the installer per NEC (or IEC 60364 in Europe) requirements.

For power supply and machine ground connections, use 75 °C wire, and refer to local building codes.

Verify electrical current characteristics (voltage, phase and amp draw) and capacity requirements against those listed on the name plate.

SERVICE DISCONNECT

A service disconnect must be installed per NEC requirements and governing codes.

GROUNDING REQUIREMENTS

The approved earth ground must be made with solid metal-to-metal connections and must be a good conductor of radio frequency interference (RFI) to earth (multistranded conductors).

Ground wire should be sized per NEC requirements (in Europe, IEC 60364 requirements).

A field-installed ground wire is necessary from the machine ground lug on the unit to the machine ground lug in the control cabinet. The bonding machine ground wire should be sized per NEC or IEC 60364 requirements.

WARNING

Electric shock hazard

Only qualified electrical personnel should perform field wiring installation procedures. Improper wiring or contact with energized circuits can cause property damage, severe personal injury, or death as a result of electric shock and/or fire.

Do not open control cabinet until electrical power is disconnected.

CAUTION

Damage from debris

When drilling penetrations in the control cabinet, protect all internal components from debris, and vacuum out the control cabinet when finished. Failure to comply with this directive can damage sensitive electronic components, cause erratic operation or failure, and void your DriSteem warranty.

Important:

Failure to follow these wiring procedures can result in erratic operation or failure.

This product has been tested at the factory for proper operation. Product failures resulting from faulty handling, incorrect wiring, or shorting of wires together on external components are not covered under your DriSteem warranty. Review information and diagrams before proceeding.

Wiring

WARNING

Excessive moisture hazard

DriSteem strongly recommends installing a duct airflow proving switch. This device prevents the system from operating when there is low or no airflow in the duct. Failure to install this device can result in excessive moisture in the duct, which can cause bacteria and mold growth or dripping through the duct.

Important: Do not use shielded cable for water level control devices (connections 30 – 33 on field wiring terminal block shown in Figure 39-1).

Important:

Installing the keypad/display

If the keypad/display has been shipped loose, mount it in a convenient location for easy access, but not inside the control cabinet. Mount the keypad/display using a field-supplied network phone wall plate. To mount, slide the keypad/display onto the tabs on the phone plate.

Note that the keypad/display requires an ambient temperature range of 32 °F to 122 °F (0 °C to 50 °C) to operate properly. Exceeding these limits results in a poor reading or no reading.

PREVENTING ELECTRICAL NOISE

Electrical noise can produce undesirable effects on electronic control circuits, thereby affecting controllability. Electrical noise is generated by electrical equipment such as inductive loads, electric motors, solenoid coils, welding machinery, or fluorescent light circuits. The electrical noise or interference generated from these sources (and the effect on controllers) is difficult to define, but the most common symptoms are erratic control or intermittent operational problems.

Most electrical noise problems can be prevented by using proper wiring practices and techniques to prevent coupling or inducing of electrical interference into control circuits. The following wiring practices should minimize interaction of noise and controls:

- Connect unit and control cabinet to a code approved earth ground.
- Separate the line voltage wiring from low voltage control circuit wiring when routing electrical wiring inside the control cabinet.
- Use separate electrical conduits for line and low voltage wiring to the unit.
- Do not use chassis or safety grounds as current-carrying commons. A safety ground should never be used as a conductor or neutral to return circuit current.
- When wiring sensors or control signal connections from a building control system, use 18-gauge minimum (1 mm²), plenum-rated, twisted pair wire with cable shielding and drain wire for grounding.
- Return all shielded cable connections to the control cabinet for grounding.
Do not ground shield at the device end.

CONTROL WIRING

The following wiring methods for external low-voltage control wiring should minimize electrical noise problems:

- Control wiring must be plenum-rated, shielded, twisted pair wire with a bare drain wire for grounding.
 - North America: 18-gauge minimum
 - Europe: 1 mm² minimum
- Airflow proving switch wiring must be stranded wire in conduit. The airflow proving switch can be wired using plenum-rated, shielded, twisted pair wire with a bare drain wire for grounding.
 - North America: 18-gauge minimum
 - Europe: 1 mm² minimum
- The shield wire should be connected to the shield ground terminal/lug with a length less than 2" (51 mm). Do not ground the shield wire on the humidistat or transmitter end.

Cycles of concentration

**Table 17-1:
Cycles of concentration**

		Total alkalinity as mg/l HCO ₃ ⁻																				
		10	20	30	40	50	60	70	80	90	100	125	150	175	200	250	300	350	400	450	500	
Total hardness as mg/l Ca ²⁺	10	6.0	6.0	6.0	6.0	6.0	6.0	6.0	6.0	6.0	6.0	6.0	6.0	6.0	5.5	5.0	4.4	3.9	3.5	3.2	3.0	2.8
	20	6.0	6.0	6.0	6.0	6.0	6.0	6.0	6.0	6.0	6.0	6.0	5.3	4.7	4.2	3.9	3.3	3.0	2.7	2.5	2.3	2.1
	30	6.0	6.0	6.0	6.0	6.0	6.0	6.0	6.0	6.0	5.6	5.2	4.5	4.0	3.6	3.3	2.9	2.5	2.3	2.1	1.9	1.8
	40	6.0	6.0	6.0	6.0	6.0	6.0	6.0	5.9	5.4	5.0	4.7	4.1	3.6	3.3	3.0	2.6	2.3	2.1	1.9	1.7	1.6
	50	6.0	6.0	6.0	6.0	6.0	6.0	6.0	5.5	5.0	4.6	4.3	3.7	3.3	3.0	2.7	2.4	2.1	1.9	1.7	1.6	1.5
	60	6.0	6.0	6.0	6.0	6.0	6.0	5.6	5.1	4.7	4.3	4.0	3.5	3.1	2.8	2.6	2.2	2.0	1.8	1.6	1.5	1.4
	70	6.0	6.0	6.0	6.0	6.0	6.0	5.3	4.8	4.4	4.1	3.8	3.3	2.9	2.6	2.4	2.1	1.8	1.7	1.5	1.4	1.3
	80	6.0	6.0	6.0	6.0	6.0	5.7	5.1	4.6	4.2	3.9	3.6	3.1	2.8	2.5	2.3	2.0	1.8	1.6	1.5	1.3	1.3
	90	6.0	6.0	6.0	6.0	6.0	5.5	4.8	4.4	4.0	3.7	3.5	3.0	2.6	2.4	2.2	1.9	1.7	1.5	1.4	1.3	1.2
	100	6.0	6.0	6.0	6.0	6.0	5.2	4.6	4.2	3.8	3.6	3.3	2.9	2.5	2.3	2.1	1.8	1.6	1.5	1.3	1.2	1.2
	125	6.0	6.0	6.0	6.0	5.6	4.8	4.3	3.9	3.5	3.3	3.0	2.6	2.3	2.1	1.9	1.7	1.5	1.3	1.2	1.1	1.1
	150	6.0	6.0	6.0	6.0	5.2	4.5	4.0	3.6	3.3	3.0	2.8	2.5	2.2	2.0	1.8	1.6	1.4	1.2	1.1	1.1	1.0
	175	6.0	6.0	5.9	4.9	4.2	3.8	3.4	3.1	2.9	2.7	2.3	2.1	1.9	1.7	1.5	1.3	1.2	1.1	1.0	0.9	0.9
	200	6.0	6.0	5.6	4.7	4.0	3.6	3.2	3.0	2.7	2.6	2.2	2.0	1.8	1.6	1.4	1.2	1.1	1.0	0.9	0.9	0.8
	250	6.0	6.0	5.2	4.3	3.7	3.3	3.0	2.7	2.5	2.3	2.0	1.8	1.6	1.5	1.3	1.1	1.0	0.9	0.9	0.8	0.8
	300	6.0	6.0	4.8	4.0	3.5	3.1	2.8	2.5	2.3	2.2	1.9	1.7	1.5	1.4	1.2	1.1	1.0	0.9	0.8	0.8	0.8
	350	6.0	5.9	4.6	3.8	3.3	2.9	2.6	2.4	2.2	2.1	1.8	1.6	1.4	1.3	1.1	1.0	0.9	0.8	0.8	0.7	0.7
400	6.0	5.7	4.3	3.6	3.1	2.7	2.5	2.3	2.1	2.0	1.7	1.5	1.4	1.2	1.1	1.0	0.9	0.8	0.8	0.7	0.7	
450	6.0	5.4	4.1	3.4	3.0	2.6	2.4	2.2	2.0	1.9	1.6	1.4	1.3	1.2	1.0	0.9	0.8	0.8	0.7	0.7	0.7	
500	6.0	5.2	4.0	3.3	2.8	2.5	2.3	2.1	1.9	1.8	1.6	1.4	1.2	1.1	1.0	0.9	0.8	0.7	0.7	0.7	0.6	
Cycles <2: Conductivity controlled bleed-off not recommended																						
Cycles <1.5: Direct water recommended																						
Cycles <1: Non-usable water																						

Cycles of concentration

Table 17-1 shows the maximum recommended cycles of concentration (COC) for different water qualities. Cycles of concentration = mineral concentration in humidifier water/mineral concentration in supply water. The cycle value is used to calculate the bleed off. If the cycle rate is 2 or lower, it is recommended that the supply water should be treated to improve the water quality. Table 18-1 can be used to convert local measuring units to fit the table.

The calculations in Table 18-1 are for reference. The Vapor-logic controller will automatically cycle the drain and fill valves according to the desired cycles of concentration entered.

Table 18-1: Conversion table	
Total hardness (calcium hardness)	
°dH	°dH × 7.2 → mg/l Ca ²⁺
°f	°f × 4.0 → mg/l Ca ²⁺
°clark	°clark × 5.7 → mg/l Ca ²⁺
ppm CaCO ₃	ppm CaCO ₃ × 0.25 → mg/l Ca ²⁺
Total alkalinity (carbonate hardness, bicarbonate)	
°dH	°dH × 21.8 → mg/l HCO ₃ ⁻
ppm CaCO ₃	ppm CaCO ₃ × 1.2 → mg/l HCO ₃ ⁻
ppm NaOH	ppm NaOH × 1.5 → mg/l HCO ₃ ⁻
General	
Concentration	mg/l = g/m ³ = ppm
Conductivity	1 mS/m = 10 µS/cm = 10 µMHO

PROCEDURE FOR DETERMINING COC AND THE CORRESPONDING DRAIN STRATEGY

1. Test your supply water and choose your desired / required COC from the chart above
2. Given your system operating conditions, calculate the water evaporation rate: E (gallons/hour [liters/hour])
 $E = (1.2 * CFM * (IT_d - ET_d)) / 10,000$
 $(E = (4.8 * CMH * (IT_d - ET_d)) / 10,000)$

3. Water must be periodically drained from the tank to maintain the desired COC, calculate the required drain rate: D (gallons/hour [liters/hour])
 $D = E / (C - 1)$
 - C = desired cycles of concentration
 - E = evaporation rate
4. Total flow rate required for the system are
 $T = E + D$ GPH (LPH)
5. CFM = cubic feet per minute air flow
 CMH = cubic meters per hour air flow
 - IT_d = incoming dry bulb temperature
 - ET_d = exiting dry bulb temperature
6. To achieve that drain rate, several drain events must take place over the course of an hour. The frequency of drain events and corresponding gallons (liters) drained per event are based on customer preference.
 - More frequent drain events where smaller volumes of water are drained will result in tighter COC control but more drain valve ware
 - Less frequent drain events where larger volumes of water are drained will result in looser COC control but less wear on the drain valve.
7. Figure 19-1 shows the number of gallons (liters) that will be drained through the drain valve during a given period of drain activation. Select a desired drain duration and corresponding gallons per drain.
 - The gallons (liters) drained includes the volume drained while power is provided to the drain as well as the volume drained while the valve is closing.
 - Graph will be provided seconds of drain vs. gallons (liters) per drain.
 - S = seconds per drain
 - g = gallons per drain
8. Calculate the required frequency of drain events: df ((drain events)/hour)
 - $df = D / g$ (l)
 - D = drain rate
 - g (l) = gallons (liters) per drain
9. Now control the drain to power on (df) timer per hour for your chosen (S) seconds

Cycles of concentration

FIGURE 19-1: WATER DRAINED OVER TIME

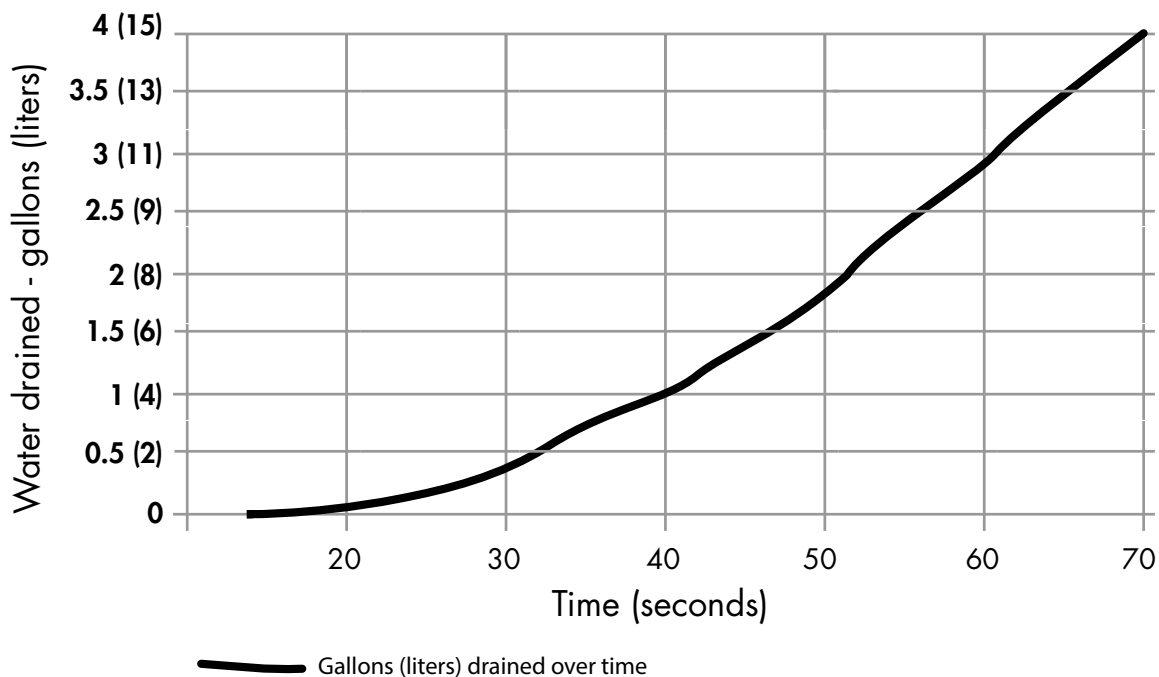

WATER FROM OTHER SOURCES

If the supply water is not classified as drinking water from the mains the following additional concentration limits are recommended.

- Chlorides (mg/l Cl) Cl- × C < 200 mg/l
- Sulphates (mg/l SO₄²⁻) SO₄²⁻ × C < 300 mg/l
- Bacteria rate (CFU/ml, KBE/ml) CFU/ml × C < 1000

Multiply the concentration by the cycle ratio (C) and compare to the recommended limit. If the value is over the limit, reduce the cycle rate.

When using softened water, the total hardness can't be used for dimensioning the bleed-off. Instead use a conductivity limit of 1000µS/cm to calculate the cycle ratio. Supply conductivity × C < 1000µS/cm.

In poor water quality areas, a blend of treated water and raw water can be used to lower the mineral content. The water should be blended so that the conductivity > 100µS/cm.

EXAMPLE CONDITIONS

- Makeup Water Alkalinity:- 90 mg/l HCO₃
- Makeup Water Hardness: 100 mg/l Ca²
- Air handler is moving 25,000 CFM (42.475 CMH)
- Entering temperature 95°F (35°C)
- Exiting temperature 85°F (29.5°C)

EXAMPLE CALCULATIONS

1. Per Table 17-1 the recommended cycles of concentration would be 3.6.
2. E = (1.2*25,000*(95-85)) / 10,000 = 30 GPH
(E = (4.8*42,475*(35-29.5))/10,000=112 LPH)
3. D = 30 / (3.6-1) = 11 GPH
(D = 112 / (3.6-1) = 43 LPH)
4. T = 30 + 11 = 41 GPH
(T = 112 + 43 = 155 LPH)
5. Continue to next step.
6. A 45 second, 1.5 gallon (6 liter) drain event is selected.
7. df = 11/1.5 = 7 drain events per hour (45 seconds each)
(df = 43/6 = 7 drain events per hour (45 seconds each))

Start-up checklist

If an item in the Start-up checklist below does not apply to your system, skip to the next item and continue the process.

- Read this manual and all other information that was provided with your system.
- Verify that all field wiring is done according to the instructions in this manual and in the unit wiring diagram.
- Confirm that the input signal is consistent with the Vapor-logic controller's expected input signal. Input signals are listed in the Vapor-logic Setup menu. See "Installation Step 2: Setup" in the Vapor-logic Controller Installation and Operation Manual.
- Confirm that proper grounding and an approved earth ground are provided.
- Confirm that the keypad/display is mounted with its modular cable routed away from high-voltage circuits and connected to the Display connector on the Vapor-logic board.
- Turn on power to the unit, and confirm the Main menu is displayed on the keypad/display. The display may take several seconds to appear as the controller powers up.
- Turn on the water supply, and confirm that the normally open drain valve is closed.
- Confirm in the Main Menu that the mode is Auto and that status is Idle.
- When "Idle" appears in main menu, confirm that there is at least 25 psi (170 kPa) at the fill valve. Allow the tank to fill with water.
- In the Status screen, confirm that the Duct Airflow Switch is closed.
- Navigate to the Settings menu, and enter the Cycles of Concentration setting recommended by DriSteem. Use the calculation method on pages 17 and 18, or contact DriSteem if you do not know the value to enter for your application's supply water.
- With sufficient water available, the airflow switch closed, the safety interlock closed, and the unit getting a demand signal, verify that the pump or pumps are activated.
- Monitor system activity, and watch for drips or leaks in the duct or AHU. If a leak is found:
 - a. Remove demand signal, and put system in Standby mode.
 - b. Tighten any loose connections.
 - c. Return system Auto mode.
- Verify that the UV lamp is on. The LED on the power wiring end of the cylinder is illuminated when the UV lamp is on.
- To reduce water waste and extend media life: Before leaving the system in Auto mode for the long term, adjust water recirculation/flushing parameters based on your application and water chemistry. See "Cycles of concentration" on page 30.
- If you experience difficulties, have the keypad/display information available along with the serial number and unit Model, and call DriSteem Technical Support at 800-328-4447.
- Return the system to the desired mode.

TEST RUN

The Vapor-logic controller has a test run capability to confirm system functionality. This capability allows a technician to simulate a demand when there is no demand (such as when performing routine maintenance). To confirm functionality, go to the test run section of the Diagnostics menu. Set system demand percent and test run time duration. During testing, the mode changes to Standby, and the tank status changes to Test.

TEST OUTPUTS

When completing an installation or repair, cycle all outputs to verify operation. Go to the test outputs section of the Diagnostics menu, and scroll through each connected output to verify operation. During testing, the unit mode changes to Standby, and the tank status changes to Test.

Keypad/display

FIGURE 21-1: KEYPAD/DISPLAY HOME SCREEN

Typical Home screen

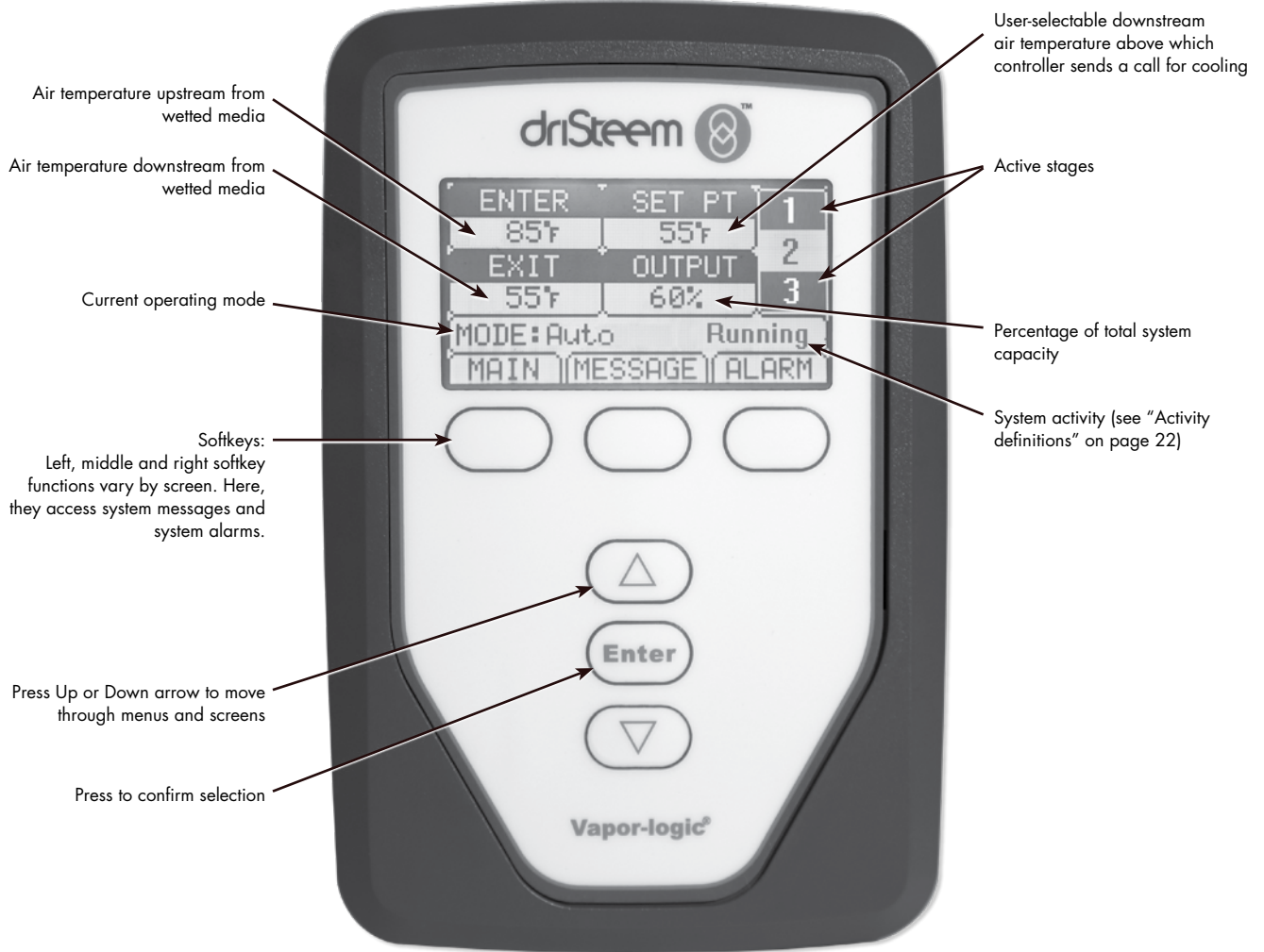

Keypad/display

The Vapor-logic keypad/display returns to the Home screen after a user-defined period of idle time. The Home screen displays the items most frequently viewed.

CHANGING MODE AND SET POINT

Mode and Set point can be changed from the Home screen:

1. Press the Up or Down arrow key to highlight the item to be changed, and press the Enter key to enter the menu.
2. Press the Up or Down arrow key to scroll to the desired selection, and press the Enter key to confirm.

The following section explains how to change other parameters displayed in the Home screen.

CHANGING OTHER PARAMETERS

Access the Setup menu on the keypad/display as follows:

1. Press the Main softkey.
2. Press the Down arrow key until Setup is highlighted.
3. Press the Enter key to confirm.

After entering the Setup menu, press the Up and Down arrows to scroll through the setup parameters or to change values. Use the Enter key to confirm selections.

ACTIVITY DEFINITIONS

Idle: No demand, or an active system alarm is preventing operation.

Running: System is supplying water to meet demand.

Alarm: System has an active alarm.

Flush: System is performing a flush.

Drying: System is automatically drying out the reported stage. Operation will resume when dry-out is completed.

Draining: System is draining the tank because:

Manual Drain was selected,

or

the end-of-season threshold has been reached.

Note: The end-of-season feature shuts off the supply water and drains the tank when there is no demand for 72 hours. This length of time is a default setting and is user-adjustable. See the *Vapor-logic Installation and Operation Manual* for more information.

CONNECTING TO THE NETWORK

The Vapor-logic controller is configured to be connected to a router with a DHCP server available. The controller is configured to automatically find IP addresses on the network.

If a DHCP server is not available, the controller will need to be configured with a unique static IP address. Go to Setup > Communications > Network IP address on the keypad/display to change the IP address.

WEB INTERFACE COMMUNICATION

Utilizing the Vapor-logic Web interface is optional. The Wetted Media System can be operated using the keypad/display or Web interface or both. When using the Web interface, the system can be accessed through a network.

Status screen

Table 23-1:
Status screen

Note: Your system might not have all of the items listed in this table.

Menu item	Default value	Minimum value	Maximum value	Units	Notes
Run mode	Standby	—	—	—	<p>Operating modes. Choose from Auto, Standby, or Flush.</p> <ul style="list-style-type: none"> In Auto mode, the system operates normally. All components are monitored and controlled. If there is a call for cooling/humidification, the system reacts. In Standby mode, the system is offline. All control inputs appear but are not acted upon; however, if the water temperature falls below the freeze protect set point, the drain valve opens. In Flush mode, the drain valve opens to drain the tank. System operation is suspended, and the drain valve remains open until the model-specific flush time is met or the system is taken out of Flush mode. See Test outputs and Test run modes on page 22.
Input signal	—	0	10	VDC	
	—	0	20	mA	
Demand	—	0	100	%	Demand as a percent of system capacity
Output	—	0	100	%	
UV light	—	Off	On	—	
Wet bulb estimate	—	-50	250	°F	Sensor range
	—	-46	121	°C	Sensor range
Hours until service	1,000	0	10,000	hours	
Output air temperature	—	20	120	°F/ °C	
Output set point	55	40	120	°F/ °C	
Stage 1 efficiency	—	0	100	%	
Stage 2 efficiency	—	0	100	%	
Stage 3 efficiency	—	0	100	%	
UV time	9,000	0	9,000	hours	
Supply water conductivity	—	0	1,000	µs	Optional conductivity sensor
Incoming air temperature	—	-20	160	°F	Air temperature upstream of wetted media
	—	-29	71	°C	
Stage 1 temperature	—	-20	160	°F	Downstream air temperature, Stage 1
	—	-29	71	°C	
Stage 2 temperature	—	-20	160	°F	Downstream air temperature, Stage 2
	—	-29	71	°C	
Stage 3 temperature	—	-20	160	°F	Downstream air temperature, Stage 3
	—	-29	71	°C	
Stage 1, 2, 3	—	On	Off	—	

Diagnostics and Alarms

Table 24-1:
Diagnostics menu

Message	Description	Auto-clear?
Service unit	Regularly scheduled unit servicing is due	No
Replace UV lamp	Scheduled UV lamp replacement time has been reached (every 9000 hours)	No
No airflow	No duct airflow	Yes
Lock open	Interlock safety switch is open	Yes
EOS active	The system is draining or has drained. System remains inactive until receiving another call.	Yes
Stage 1 temperature sensor efficiency below 50%	Stage 1 media is becoming clogged. Clean media or replace.	Yes
Stage 2 temperature sensor efficiency below 50%	Stage 2 media is becoming clogged. Clean media or replace.	Yes
Stage 3 temperature sensor efficiency below 50%	Stage 3 media is becoming clogged. Clean media or replace.	Yes

Notes:

- Messages Log displays message name, date, and time of occurrence, plus "Active," "Cleared" or "Auto-cleared."
- Active messages display first in the Messages Log, followed by cleared messages (auto-cleared and/or manually-cleared) listed in order of occurrence.
- Messages Log displays a maximum of 10 messages. Cleared messages leave the log first.
- If a message event occurs and is not manually or auto cleared during unit operation, the message will stay there until there is demand and the unit is running.

Table 24-2:
Alarms menu

Alarm label	Description	Auto-clear?
Tank temperature failed	Tank temperature failed	Yes
Incoming air temperature sensor	Air temperature upstream of wetted media is out of range	Yes
Stage 1 temperature sensor	Air temperature downstream of Stage 1 is out of range	Yes
Stage 2 temperature sensor	Air temperature downstream of Stage 2 is out of range	Yes
Stage 3 temperature sensor	Air temperature downstream of Stage 3 is out of range	Yes
Demand signal	Demand signal is out of range	Yes

Notes:

- See the "Troubleshooting" section in the Vapor-logic Controller Installation and Operation Manual for alarm possible causes and recommended actions.
- The Alarms Log displays alarm name, date and time of occurrence, plus "Active," "Cleared" or "Auto-cleared."
- Active alarms display first in the Alarms Log, followed by cleared alarms (auto-cleared and/or manually-cleared) listed in order of occurrence.
- The Alarms Log displays maximum 30 alarms. Cleared alarms leave the log first.
- If an alarm event occurs and is not manually cleared or auto-cleared during unit operation, the alarm will remain until there is demand and the unit is running.

Modbus, BACnet, LonTalk interoperability

Table 25-1:
Interoperability variable and object names

Variable name and BACnet object name	Read Only (RO) or Read Write (RW)	Modbus register number*	BACnet Object Type and Instance	LonTalk variable names**	Description	Units		Range	
						I-P units	SI units	I-P units	SI units
Read-only analog variables									
Space_dew_point	RO	IR-2 30002	AI-02	nvoSpaceDewPoint	Dew point of the air in the space being humidified.	°F	°C	20 to 80	-6 to 26
Demand_mass	RO	IR-4 30004	AI-04	nvoSteamDmndMass	Demand in pounds or kilograms per hour.	lbs/hr	kg/h	0 to 100,000	0 to 100,000
Demand_percent	RO	IR-5 30005	AI-05	nvoSteamDemand%	Demand as a percentage of the system's total capacity.	%	%	0 to 100	0 to 100
Aux_temp	RO	IR-6 30006	AI-06	nvoAuxTemp	Temperature of auxiliary temperature sensor.	°F	°C	-20 to 160	-29 to 170
Water_temp	RO	IR-7 30007	AI-07	nvoTankTemp	Temperature of the water in the tank.	°F	°C	-240 to 265	-151 to 129
Output_mass	RO	IR-8 30008	AV-1	nvoSteamOutMass	Estimated amount of water the system is evaporating in pounds or kilograms per hour.	lbs/hr	kg/h	0 to 100,000	0 to 100,000
Output_percent	RO	IR-9 30009	AV-2	nvoSteamOutput%	Estimated amount of water the system is evaporating as a percentage of total system capacity.	%	%	0 to 100	0 to 100
Water_until_ADS	RO	IR-10 30010	AV-3	nvoWaterUntilADS	Weight of water remaining to be evaporated before the next automatic drain sequence (ADS) cycle.	100 lbs	100 kg	0 to 2,200,000	0 to 1,000,000
Water_until_service	RO	IR-11 30011	AV-4	nvoWaterTilSrvc	Weight of water remaining to be evaporated before next service cycle.	100 lbs	100 kg	0 to 2,200,000	0 to 1,000,000
MT_sys_output_mass_hr	RO	IR-23 30023	AI-08	nvoMT_SteamOMass	MT steam demand mass	lbs/hr	kg/h	0 to 100,000	0 to 100,000
MT_sys_output_pcnt	RO	IR-25 30025	AI-09	nvoMT_SteamO%	MT steam demand percent	%	%	0 to 100	0 to 100
C_O_C	RO	IR-30	AI-14	nvoCurrentCOC	Cycles of concentration.	—	—	1.5 to 12	1.5 to 12
Supply_water_conductivity_μs	RO	IR-31	AI-15	nvoSupply_us	Supply water conductivity	μs	μs	0 to 1,000	0 to 1,000
Stage 1 temperature	RO	IR-32	AI-16	nvoStage1Temp	Stage 1 temp	°F	°C	-20 to 160	-29 to 71
Stage 2 temperature	RO	IR-33	AI-17	nvoStage2Temp	Stage 2 temp	°F	°C	-20 to 160	-29 to 71
Stage 3 temperature	RO	IR-34	AI-18	nvoStage3Temp	Stage 3 temp	°F	°C	-20 to 160	-29 to 71
Supply_air	RO	IR-35	AI-19	nvoSupplyAirTemp	Incoming air temp	°F	°C	-20 to 160	-29 to 71
WM_stage_1_media_effectiveness	RO	IR-36	AI-20	nvoStage1Effect	Stage 2 effectiveness	%	%	0 to 100	0 to 100

* See Note 1 on page 29.

** See Note 2 on page 29.

Continued

Modbus, BACnet, LonTalk interoperability

Table 25-1:
Interoperability variable and object names (continued)

Variable name and BACnet object name	Read Only (RO) or Read Write (RW)	Modbus register number*	BACnet Object Type and Instance	LonTalk variable names**	Description	Units		Range	
						I-P units	SI units	I-P units	SI units
Read-only analog variables (continued)									
WM_stage_2_media_effectiveness	RO	IR-37	AI-21	nvoStage2Effect	Stage 2 effectiveness	%	%	0 to 100	0 to 100
WM_stage_3_media_effectiveness	RO	IR-38	AI-22	nvoStage3Effect	Stage 3 effectiveness	%	%	0 to 100	0 to 100
WM_output_temperature	RO	IR-39	AI-23	nvoOutputTemp	Outlet temperature	°F	°C	20 to 120	-7 to 49
WM_wet_bulb_temperature	RO	IR-40	AI-24	nvoWetBulbTemp	Wet bulb temperature	°F	°C	20 to 120	-7 to 49
WM_target_coc	RO	HR-20	AV-18	nviTargetCOC	Target COC	—	—	1.5 to 12	1.5 to 12
Setup variables									
Run_mode	Write	HR-1 40001	MSV-01	nviRunMode	Mode of the unit or system. The defined options are: 1 Auto 2 Local standby 3 System standby 4 Manual drain	—	—	1 to 4	1 to 4
	Read	HR-1 40001	MSV-01	nvoRunMode	Mode of the unit or system. The defined options are: 1 Auto 2 Local standby 3 System standby 4 Manual drain 5 Test outputs 6 Test run	—	—	1 to 6	1 to 6
Space_dew_point_set_point	Write	HR-3 40003	AV-06	nviSpaceDewPtSP	Dew point set point for the space being humidified.	°F	°C	20 to 80	-6 to 26
Fieldbus_demand_mass	Write only	HR-5 40005	AV-08	nviFbusDemndMass	Steam output (as demanded via fieldbus) in pounds or kilograms per hour. If the request exceeds the unit's capacity, the unit will run at 100% capacity.	lbs/hr	kg/h	0 to 100,000	0 to 100,000
Fieldbus_demand_%	Write only	HR-6 40006	AV-09	nviFldBusDemand%	Steam output (as demanded via the fieldbus) as a percentage of the humidifier's total capacity.	%	%	0 to 100	0 to 100
PID_band	RW	HR-7 40007	AV-10	nciPIDband	PID band.	%	%	0 to 50	0 to 50
PID-Kp	RW	HR-8 40008	AV-11	nciPIDkp	PID-Kp (proportional gain) factor.	—	—	0 to 1000	0 to 1000
* See Note 1 on page 29.									
** See Note 2 on page 29.									

Continued

Modbus, BACnet, LonTalk interoperability

Table 25-1:
Interoperability variable and object names (continued)

Variable name and BACnet object name	Read Only (RO) or Read Write (RW)	Modbus register number*	BACnet Object Type and Instance	LonTalk variable names**	Description	Units		Range	
						I-P units	SI units	I-P units	SI units
Setup variables (continued)									
PID-Ki	RW	HR-9 40009	AV-12	nciPIDki	PID-Ki (integral gain) factor.	—	—	0 to 1000	0 to 1000
PID-Kd	RW	HR-10 40010	AV-13	nciPIDkd	PID-Kp (derivative gain) factor.	—	—	0 to 1000	0 to 1000
MT_runmode	Write	HR-14 40014	MSV-02	nviMTRunMode	"MT runmode; 1 = system standby, 2 = system auto"	—	—	1 to 2	1 to 2
	Read	HR-14 40014	MSV-02	nvoMTRunMode	"MT runmode; 1 = system standby, 2 = system auto"	—	—	1 to 2	1 to 2
MT_water_req_mass_hr	Write only	HR-15 40015	AV-14	nviMT_FBDmndMass	MT fieldbus request for water in pounds or kilograms per hour	lbs/hr	kg/h	0 to 100000	0 to 100000
MT_water_req_sys_pcpt	Write only	HR-17 40017	AV-15	nviMT_FBDmnd%	MT fieldbus request for water in percentage of system capacity	%	%	0 to 100	0 to 100
Read-only digital I/O									
Airflow_proving_switch	RO	DI-1 10001	BI-01	nvoAirflowSwitch	0=Open; 1=Closed	—	—	—	—
Safety_interlock	RO	DI-3 10003	BI-03	nvoSafetyLock	0=Open; 1=Closed				
Fill_valve	RO	DI-8 10008	BO-01	nvoFillValve	0=Closed; 1=Open				
Drain_valve	RO	DI-9 10009	BO-02	nvoDrainValve	0=Not Draining; 1=Draining				
MT_active_fault_exists_somewhere	RO	DI-10 10010	BI-08	nvoMt_AlarmSomWr	0=No; 1=Yes	Multi-tank only			
MT_active_message_exists_somewhere	RO	DI-11 10011	BI-09	nvoMt_MsgSomWr	0=No; 1=Yes	Multi-tank only			
* See Note 1 on page 29.									
** See Note 2 on page 29.									

Modbus, BACnet, LonTalk interoperability

Table 25-1:
Interoperability variable and object names (continued)

Variable name and BACnet object name	Read Only (RO) or Read Write (RW)	Modbus register number*	BACnet Object Type and Instance	LonTalk variable names**	Description	Units		Range	
						I-P units	SI units	I-P units	SI units
Faults and alarms									
Active_messages_exist	RO	DV-1 1	BV-01	nvoMessages	Reserved				
Active_auto_cleared_alarms_exist	RO	DV-2 2	BV-02	nvoAlarms1					
Active_manually_cleared_alarms_exist	RO	DV-3 3	BV-03	nvoAlarms2	Flags all manually cleared alarms				
Clear_all_faults	RW	DV-4 4	BV-04	nviClearAllFaults	When set will clear all active faults				
Alarm_tank_temp_sensor_failed	RW	DV-5 5	BV-05	nvoAlrmTnkTmpSen	See Table 24-2, Alarms menu				
Alarm_tank_overtemp	RW	DV-6 6	BV-06	nvoAlrmOvertemp					
Alarm_dew_pt_sig_out_of_range	RW	DV-7 7	BV-07	nvoAlrmDewPtSgnl					
Alarm_demand_sig_out_of_range	RW	DV-7 7	BV-07	nvoAlrmDemndSgnl					
Alarm_aux_temp_sens_out_of_rnge	RW	DV-9 9	BV-09	nvoAlrmAuxTemp					
Alarm_water_probe_miswired	RW	DV-10 10	BV-10	nvoAlrmProbeWire					
Alarm_water_probe_failed	RW	DV-11 11	BV-11	nvoAlrmProbeFail					
Alarm_excess_fill_time	RW	DV-12 12	BV-12	nvoAlrmFillTime					
Alarm_excess_refill_time	RW	DV-13 13	BV-13	nvoAlrmRefilTime					
Alarm_tank_not_draining	RW	DV-14 14	BV-14	nvoAlrmNoDrain					
Message_service_unit	RW	DV-39 39	BV-39	nvoMsgSrviceUnit					
Message_drain_pending	RW	DV-40 40	BV-40	nvoMsgDrainPend					
Message_no_duct_airflow	RW	DV-41 41	BV-41	nvoMsgNoDuctAir					
Message_interlock_open	RW	DV-42 42	BV-42	nvoMsgllockOpen					
Message_freeze_prevent_draining	RW	DV-43 43	BV-43	nvoMsgFreezDrain					
Alarm_excess_water_no_demand	RW	DV-15 15	BV-15	nvoAlrmXessWater					

* See Note 1 on page 29.

** See Note 2 on page 29.

Continued

Modbus, BACnet, LonTalk interoperability

Table 25-1:
Interoperability variable and object names (continued)

Variable name and BACnet object name	Read Only (RO) or Read Write (RW)	Modbus register number*	BACnet Object Type and Instance	LonTalk variable names**	Description	Units		Range	
						I-P units	SI units	I-P units	SI units
Faults and alarms (continued)									
Message_end-of-season_active	RW	DV-44 44	BV-44	nvoMsgEOSActive	See Table 24-2, Alarms menu	—	—	—	—
Message_clean_probes	RW	DV-46 46	BV-46	nvoMsgCleanProbe					
Message_insufficient_water	RW	DV-49 49	BV-49	nvoMsgH2Ocutout					
Insufficient_supply	RW	DV-49 49	BV-49	nvoMsgH2Ocutout					
Message_master_enable_open	RW	DV-60 60	BV-60	nvoMsgMasterEnb					
Alarm_temp_in	RW	DV-31	BV-31	nvoAlrmBlower4					
Alarm_temp_stage_1	RW	DV-28	BV-28	nvoAlrmBlower1					
Alarm_temp_stage_2	RW	DV-29	BV-29	nvoAlrmBlower2					
Alarm_temp_stage_3	RW	DV-30	BV-30	nvoAlrmBlower3					
Message_replace_UV_lamp	RW	DV-38	BV-38	nvoMsgReplCntctr					
Notes: 1. Modbus Input Registers (IR1-IR11) 16 bit read only Modbus Holding Registers (HR1-HR10) 16 bit read/write Modbus Discrete Input Registers (DI1-DI9) single bit read only Modbus Coil Registers (DV1-DV50) single bit read/write 2. nvi LonTalk SNVTs are write-only; nvo are read-only									

Controller-initiated media care

CYCLES OF CONCENTRATION

Cycles of concentration can be described as the number of tank fills that go through the Wetted Media System before evaporating or getting drained from the tank. Setting the cycles of concentration for your water type significantly prolongs media life and reduces water waste.

This is how it works:

Water is pumped from the tank to the distribution header, where it spreads out and falls along the width of the media. A portion of the water evaporates, while the remainder flows to the tank. This flow is important, because it flushes the media by carrying away dissolved minerals. As a result, the mineral content of the tank water gradually increases. Eventually, the mineral-laden water must be replaced with fresh water. The Wetted Media System does this by draining water from the tank and replacing it with fresh supply water. The controller adjusts these drains and fills to manage how many times it lets unevaporated water cycle through the system before draining it.

Supply water hardness is the determining factor in how many cycles of concentration to program into the controller. If you have not received a cycles-of-concentration recommendation for your water type, contact DriSteem with the following information about your supply water:

- Calcium hardness (as CaCO_3) (grains or ppm)
- Alkalinity (as CaCO_3)
- Conductivity (μmhos)
- Temperature

Most municipalities have this information available. Test kits for well water are available at most retailers that sell water treatment systems. Contact DriSteem if you need help obtaining water analysis.

DRY-OUT CYCLING

The controller is programmed to only automatically initiate a dry-out cycle after 24 hours of continuous use of a particular media stage. If a stage is not in use due to a low demand signal, the controller will monitor that "down time" and will reset that stage's 24 hour counter if the media completely dries out. A dry-out cycle will be complete when upstream and downstream temperatures are equivalent. This feature ensures dry-out cycles only when needed and for only as long as needed. Dry-out cycles are important for curbing microbe growth.

Scheduled dry-out intervals should not be used. Daily scheduled dry-out times may force the system to dry out the media more often than necessary, which shortens media life. Too-frequent drying interrupts the flow of water that flushes the media and keeps minerals and chemicals moving to the tank, where they can be drained.

Equally important, do not interrupt controller-initiated dry-out cycles.

Media

Evenly distributed water is the most important contributing factor to long media life. Water flow flushes away dirt and contaminants, which may be harmful to the media. Areas starved for water will be the first to clog or soften. To ensure that water gets evenly distributed across the entire media surface, make sure the system is level from side to side and from front to back. Other factors affecting media life:

- Often, the major influence on microbial growths and odors is lack of maintenance on the tank and media. Keep in mind the following:
 - Algae, bacteria, and fungi cannot proliferate without nutrients. Eliminate and control sources of nutrients to eliminate microbes.
 - Algae, bacteria and fungi need moisture to live. Ensure that the bottom of the media cassette is not touching the water.
 - Do not override the system's automatic, dry-out cycles.
- Oxidizing biocides (such as chlorine and bromine) are not recommended for reducing algal and microbial growth in Wetted Media System. They are unstable and can soften and destroy the media.

DriSteem recommends nonoxidizing biocides, such as isothiazolin, methylene bis-thiocyanate, 2,2-Dibromo-3-Nitrilopropionamide (DBNPA), and carbamates. These chemicals are available from industrial water treatment specialists and should be used in strict accordance with the instructions on their product labels.

- Contact DriSteem for media care recommendations for your application.

Note: Foaming of the water may occur during initial startup. This is a normal part of startup with new media. Remove the foam by initiating multiple drain cycles or by using a commercially available defoaming agent until the foam is gone. (Defoaming agent is available at carpet cleaning or spa dealers).

WARNING

Shutdown procedure

Follow this shutdown procedure before performing service or maintenance procedures on any part of the system.

1. Use Vapor-logic keypad/display to change mode to Standby.
2. Place all power disconnects in OFF position and lock in OFF position.
3. Close the field-installed manual water supply shut-off valve.

TEST RUN

The Vapor-logic controller has a test run capability to confirm system functionality. This capability allows a technician to simulate a demand when there is no demand (such as when performing routine maintenance). To confirm functionality, go to the test run section of the Diagnostics menu. Set system demand percent and test run time duration. During testing, the mode changes to Standby, and the tank status changes to Test.

TEST OUTPUTS

When completing an installation or repair, cycle all outputs to verify operation. Go to the test outputs section of the Diagnostics menu, and scroll through each connected output to verify operation. During testing, the unit mode changes to Standby, and the tank status changes to Test.

Pumps

Pump maintenance requirements depend on water hardness. Inspect the pump inlet after a few weeks of operation for scale build-up. If there is scale build-up, follow the procedure below to inspect and clean the rotor assembly. See Figure 32-1.

1. Follow shutdown procedure on page 31.
2. Remove housing screws (4) securing impeller casing (1) to motor (5).
3. Remove impeller casing from motor.
4. Remove rotor assembly (3).
5. Inspect and clean all parts. Replace pump if necessary.
6. If replacing pump, skip to step 7. Otherwise, reassemble pump as follows:
 - a. Install o-ring (2) onto impeller casing.
 - b. Carefully slide rotor assembly into motor, ensuring that holes align.
 - c. Check to ensure that rotor assembly rotates freely.
 - d. Using the four housing screws, attach impeller casing to motor, ensuring that o-ring remains in place.
7. Open field-installed manual water supply shut-off valve.
8. Return system to service, and make sure it is operating properly.

FIGURE 32-1: RECIRCULATION PUMPS

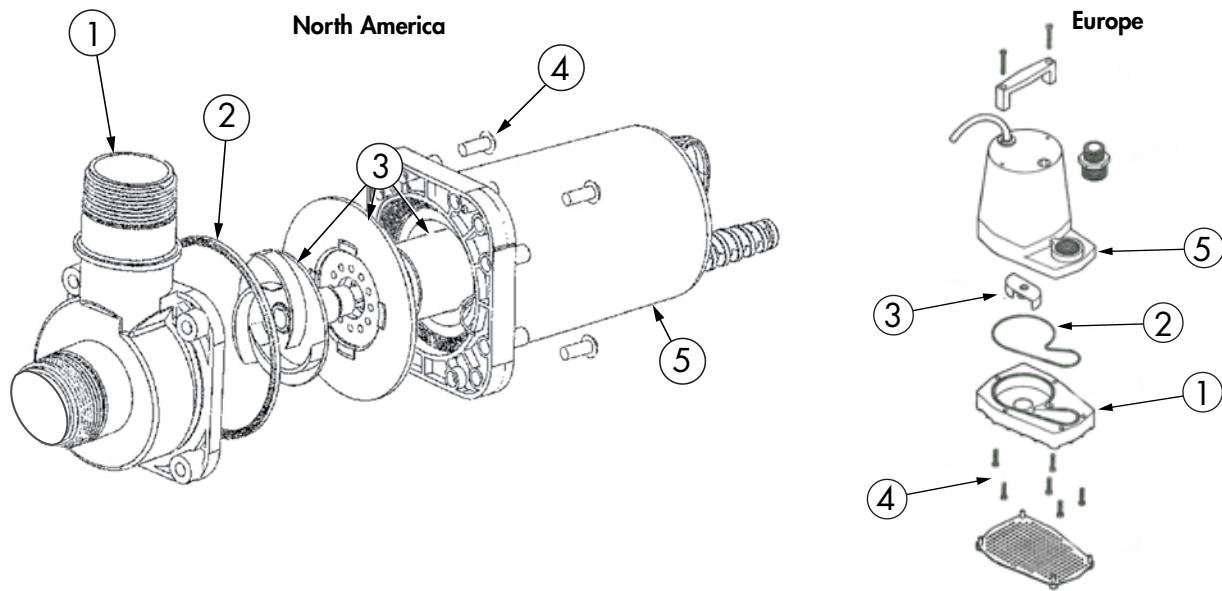

Images courtesy of Franklin Electric Co., Inc.

UV lamp replacement

The controller displays a message after 9000 hours of use when the lamp needs to be replaced. There is no need to disconnect the system from the water supply or to drain the UV chamber, and lamp replacement requires no special tools.

1. Follow shutdown procedure on page 31. Do not run system while replacing lamp.
2. Slide UV assembly and components apart from each other to create at least 15" (380 mm) clearance for lamp removal. See Figure 33-1.

FIGURE 33-1: CLEARANCE FOR LAMP AND QUARTZ SLEEVE REMOVAL

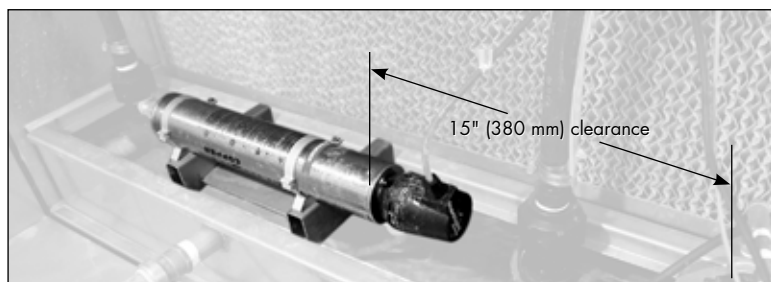

3. Pull metal retainer clip out of connector slot (Figure 33-2-A).
 4. Remove connector from UV chamber (Figure 33-2-B).
 5. **Do not remove retaining nut.** Slide UV lamp straight out of UV chamber (Figure 33-2-C).
- Note:** Avoid angling the lamp when removing it. Stress against the quartz sleeve inside of the UV chamber could cause the sleeve to break.
6. Dispose of UV lamp following hazardous waste procedures.
 7. Touching only ceramic ends, remove new lamp from protective packaging.
 8. Insert lamp straight into UV chamber, leaving about 2" (50 mm) of lamp protruding from chamber (Figure 33-2-D).

Note: Touch only ceramic ends of UV lamp.

9. Make sure retainer clip is pulled away from body of connector. Align notch on connector with grounding lug on UV chamber, and attach connector to lamp (Figure 33-2-E).
10. Pressing connector onto UV chamber (Figure 33-2-F), push retainer clip into slot. Make sure retainer clip engages with retaining nut.
11. Open field-installed manual water supply shut-off valve.
12. Return system to service, and make sure it is operating properly.

FIGURE 33-2: UV LAMP

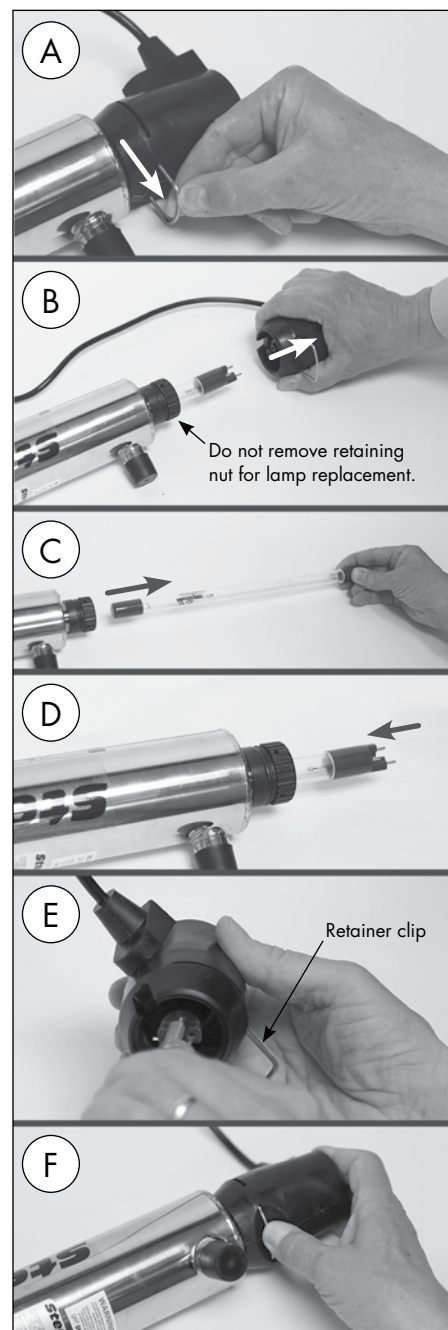

UV assembly quartz sleeve replacement

Deposits and sediment on the quartz sleeve can decrease the effectiveness of the UV lamp. Inspect the quartz sleeve periodically; cleaning frequency depends on water hardness.

Quartz sleeve replacement requires no special tools.

Note: Properly maintained supply water will reduce the accumulation of residue on the quartz sleeve.

1. Follow shutdown procedure on page 31.
2. Shut off upstream water supply that feeds water into UV chamber.
3. Remove UV lamp as explained in steps 2 through 5 on page 33.
 - Note:** If not replacing the UV lamp, touch only the ceramic ends of the lamp when removing and handling it.
4. Remove retaining nut (Figure 34-1-A).
5. Pull quartz sleeve straight out of UV chamber (Figure 34-1-B).
 - Note:** Avoid angling the sleeve when removing it. Stress against the sides of the UV chamber could cause the sleeve to break.
6. Clean quartz sleeve with commercially available scale remover and a lint-free cloth. Remove all traces of cleaning fluid from sleeve.
 - Note:** Do not allow liquid inside of sleeve.
7. Push quartz sleeve straight into UV chamber (Figure 34-1-C).
 - Note:** The UV chamber has guides to center the sleeve during insertion.
8. Lubricate o-ring (with silicone release grease), and slide it onto quartz sleeve until it is against chamfered seat of UV chamber (Figure 34-1-D).
9. Thread retaining nut onto UV chamber hand-tight (Figure 34-1-E). Do not use a wrench.
10. Install UV lamp and connector as explained in steps 8 through 10 on page 33.
11. Slowly turn on water to pressurize UV chamber. Verify that there are no leaks.
12. Return system to service, and make sure it is operating properly.

FIGURE 34-1: QUARTZ SLEEVE

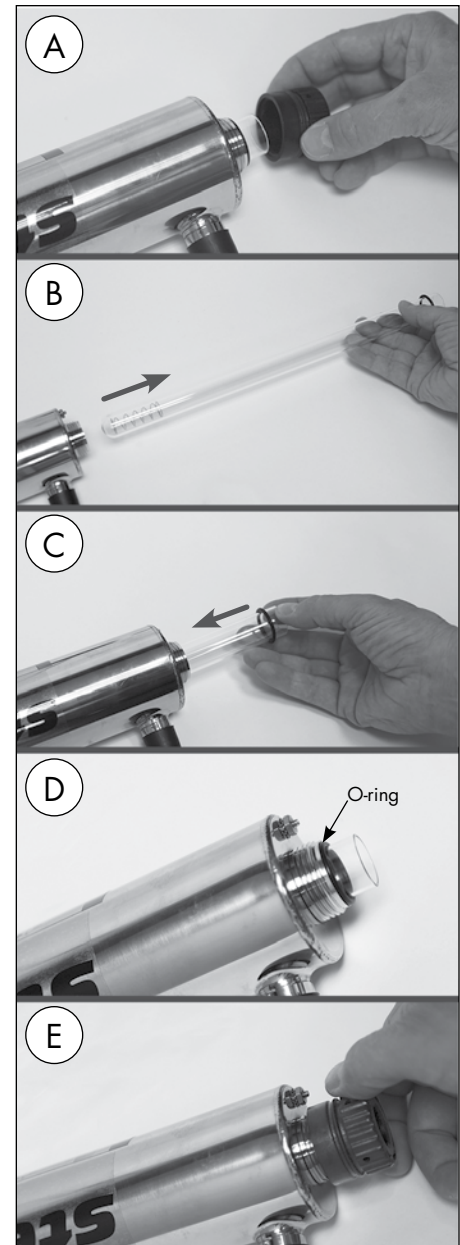

Tank and probe

TANK

Drain the tank and scrape away any loose sludge or scale from the side and bottom of the tank, and clean the overflow and drain outlets.

WATER LEVEL PROBE

Disconnect the probe plug and cable assembly, and unscrew the probe rod assembly from the top of the tank.

- Clean the probe housing, ensuring that all the housing passageways are clear.
- Clean the probe rods. The scale should flake off easily from the rods.
 - The bottom 0.4" (10 mm) of each rod is the sensing portion; clean these areas with a wire brush, emery cloth, or steel wool.
 - Inspect the composite plastic probe rod assembly for any signs of cracking, roughness, or deterioration. Replace probe assembly if necessary.

Interval maintenance

Table 36-1:
Wetted Media System maintenance intervals

Monthly	Overflow	<ul style="list-style-type: none"> • Verify that the overflow outlet is not obstructed and that water would be able exit the overflow if it got that high without overflowing the tank. • Remove residue from anywhere near the overflow outlet.
	Drain	<ul style="list-style-type: none"> • Verify that the drain outlet is not obstructed and that water exits the tank. • Remove residue from anywhere near the drain outlet.
Seasonally	UV lamp quartz sleeve	Inspect and clean if necessary. See “UV assembly quartz sleeve replacement” on page 34.
Annually	UV lamp assembly	Replace the UV lamp if it has more than 9000 hours of use. See “UV lamp replacement” on page 33.
	Pumps	Inspect the rotor assemblies to ensure that they are clean and not obstructed. If cleaning is necessary, see “Pumps” on page 32.
	Media	Inspect the media for scale or biological build-up. If cleaning is necessary, see “Media” on page 31.
	Tank	Inspect the tank for scale or biological build-up. If cleaning is necessary, see “Tank and probes” on page 35.

Replacement parts

FIGURE 37-1: WETTED MEDIA SYSTEM REPLACEMENT PARTS

2-stage system shown

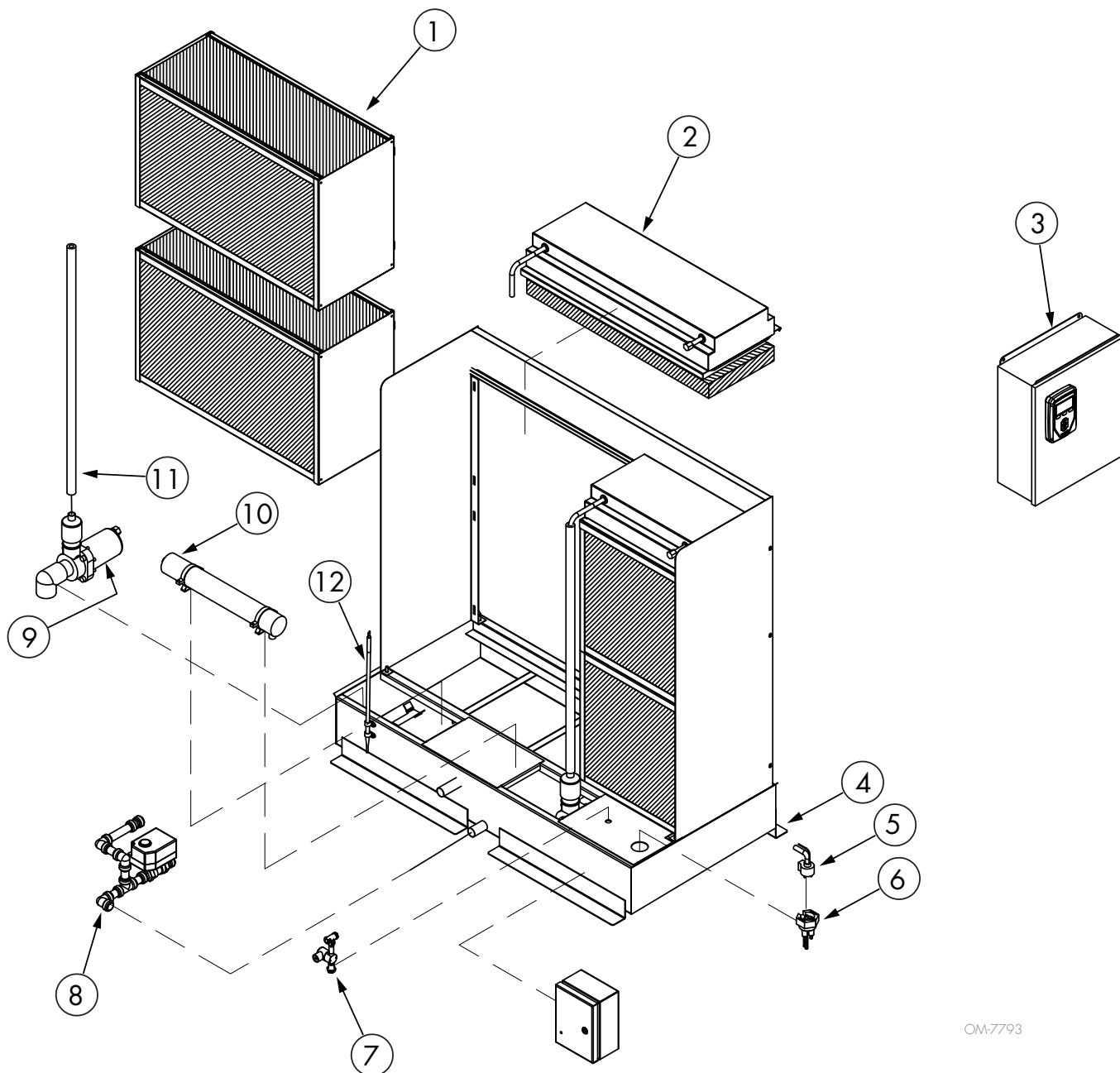

OM-7793

Replacement parts

**Table 38-1:
Wetted Media System replacement parts**

No.	Description	Qty.	Part No.
1	Media cassette	Varies with model	Contact DriSteem
2	Distribution header	1 per stack of media	
3	Control cabinet	1	See page 39
4	Tank assembly	1	Contact DriSteem
5	Probe plug assembly	1	
6	Probe assembly	1	
7	Fill valve assembly	1	
8	Drain/overflow assembly	1	
9	Pump assembly	1 per stack of media	
10	Quartz sleeve (inside of stainless steel housing shown in drawing)	1	
	UV lamp (inside of quartz sleeve)	1	
11	Hose	1 per stack of media	
12	Temperature sensor	1 per stage and 1 upstream	

Replacement parts

FIGURE 39-1: WETTED MEDIA SYSTEM CONTROL CABINET REPLACEMENT PARTS

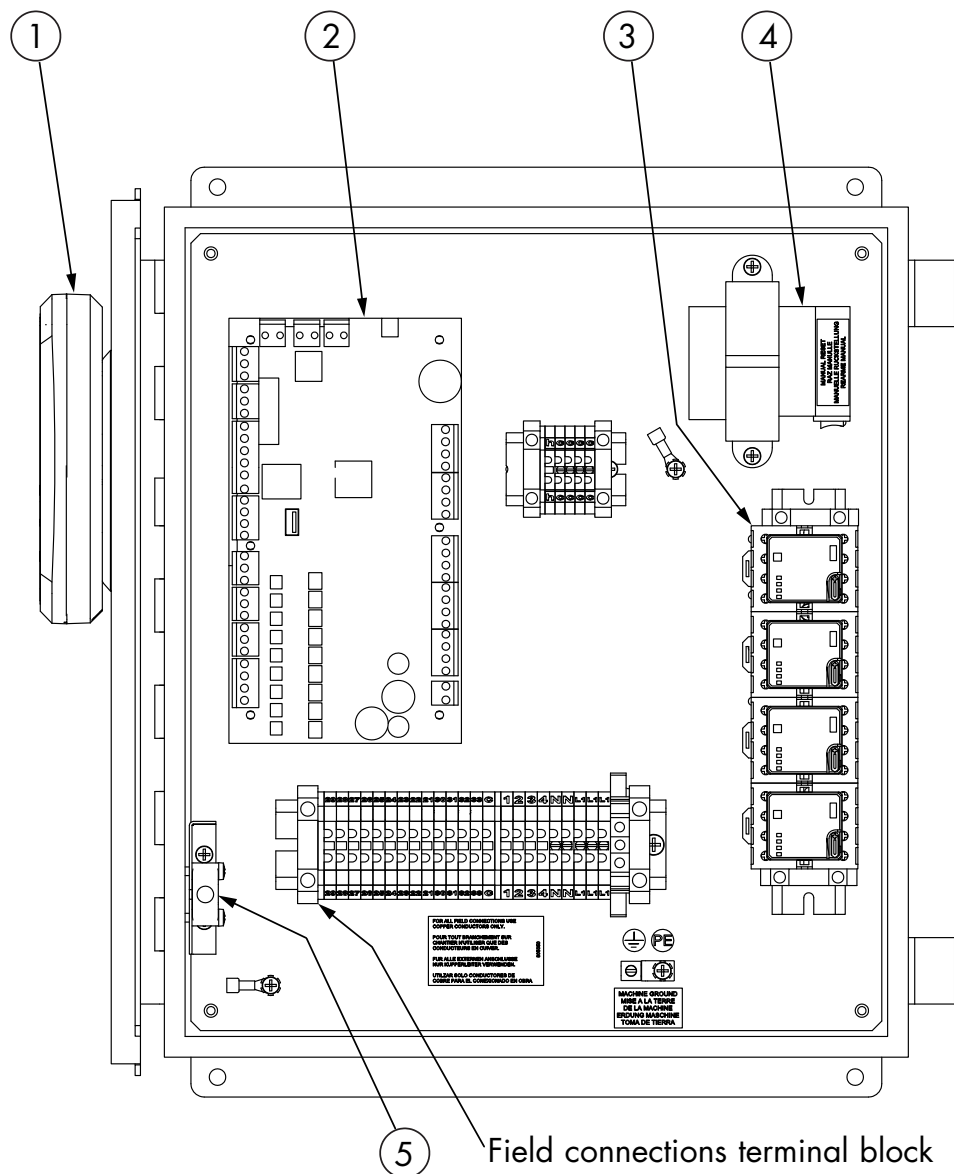

Table 39-1: Wetted Media System replacement parts			
No.	Description	Qty.	Part No.
1	Keypad/display (mounted on door)	1	408495-011
2	Vapor-logic control board	1	183504-104
2a	Vapor-logic keypad/display cable (not shown)	1	408490-014
3	Relays	Varies with models	Contact DriSteem
4	Transformer	1	408965-001
5	Door interlock switch	1	408470

Troubleshooting

The following troubleshooting table provides instructions for common issues. If the instructions in this section do not resolve your issue, please contact DriSteem Technical Support for further assistance.

The telephone numbers are on page 2.

For additional information, including messages and alarms, see the "Operation" section of this manual, beginning on page 20.

Table 40-1:
Troubleshooting

Issue	Action
System does not start in Manual or Auto mode	<ul style="list-style-type: none"> • Check the supply voltage. • Check the circuit breaker(s). • Check the control cabinet door interlock switch (shown in Figure 39-1). • Verify that the water supply valve is in the Open position. • Verify that supply water pressure is at least 25 psi (170 kPa). • Check for alarms. • Check the control and power fuses in the control cabinet and on the power panel. • Check transformer voltage(s). • Verify that the set point is lower than the temperature in the conditioned space. • Verify that the device sending the demand signal is operating. • Verify that the detection instrument is calibrated correctly. • Verify that the Pump Enable switch is in the On position.
No water appears on media	<ul style="list-style-type: none"> • Verify that the water supply is on, valves are open, and filters and screens (if any) are clean. • Check operating status to see if the system is in Idle mode. If yes, change to Auto mode. • Verify that all distribution headers are installed properly. • Verify that all pumps are operating properly. • Verify that all media cassettes are installed properly. See "Assembling tank and frame" on page 10.
Dry spots or streaks on media	<ul style="list-style-type: none"> • Water has not fully deployed through the media. Make sure water is supplied to all distribution headers, wait for a few minutes, then check again. • Remove the distribution header covers and visually inspect for clogs. Utilize flush valves at ends of spray pipe, if present. • Water inlet, orifice, or in-line filters are plugged. Inspect and clean as required. • Water flow is not properly adjusted. Adjust the amount of flow to all distribution headers. • Ensure that all distribution headers are installed properly.
Media sections have shrunken in their cassette frames.	Media may be degraded due to biological or chemical attack. Replace media cassettes if needed. See "Media" on page 31.
Water not coming out of flush lines	<ul style="list-style-type: none"> • Water is not being supplied to the distribution headers. Verify that water is turned on, and check the pumps. • Flush ball valves may be closed. Check that ball valves are open. • Flush line may be blocked or plugged. Open the valves or caps, and clean the line.
White, soft scale build-up on media	<ul style="list-style-type: none"> • Some soft scale is common on media. Excessive buildup may indicate water quality problems or uneven water distribution. See "Media" on page 31. • Clean or replace the media.
Media plugged solid with soft scale.	<ul style="list-style-type: none"> • Media was inadvertently installed backward. Reinstall, clean, or replace media. • Mineral concentration in supply water might be excessive Contact DriSteem. • Replace media if it cannot be cleaned.
Excessive debris and build-up in tank	<ul style="list-style-type: none"> • Debris and foreign objects eventually accumulate in the tank. Drain, flush, and clean tank. • Make sure there is no debris in drain outlet or overflow outlet.

Continued

Troubleshooting

Table 40-1: Troubleshooting (continued)	
Issue	Action
Water on duct or AHU floor downstream of Wetted Media System	<ul style="list-style-type: none"> • Water carryover problem. Check blank-off and seal areas for water droplets. • Water bypass problem. Check piping connections for leaks. • Check overflow outlet, and make sure tank is not overflowing • Verify that all media cassettes are properly oriented. • Verify that splash cover is installed.
Foaming on initial startup or after media replacement	<ul style="list-style-type: none"> • If water is once-through, continue to run fresh water to rinse the media. • If water is recirculated, turn off water, drain and flush tank, refill tank, and run fresh water over the media. Repeat if necessary.
Softened or settling media	<ul style="list-style-type: none"> • Media might be subjected to harsh chemicals or soft water. Test the water. • Replace pads if air can short circuit around the pads.
Musty odor from media	<ul style="list-style-type: none"> • Verify that the dry-out cycles run long enough for the media to dry out. • Verify that water distribution is adequate to sufficiently flush pads during normal operation. • Perform regular cleaning and flushing of distribution header and tank. • Adjust water level in tank so it stays below the bottom of the media. • Replace the media if it has softened or become heavily scaled.
Pump does not run	<ul style="list-style-type: none"> • Verify that pump is getting electrical power. • Inspect impeller to see if it is jammed with foreign object. Clear impeller (see "Pumps" on page 32). • Thermal overload protection has shut down pump.
Pump runs, but it does not deliver water.	<ul style="list-style-type: none"> • Tank water level is below pump inlet. • Verify that suction screen is unobstructed (see "Pumps" on page 32). • Verify that hose and orifice leading up to distribution header is unobstructed.

Expect quality from the industry leader

Since 1965, DriSteem has led the industry with innovative methods for humidifying and cooling air with precise control. Our focus on ease of ownership is evident in the design of the Wetted Media System. DriSteem also leads the industry with a Two-year Limited Warranty and optional extended warranty.

For more information

www.dristeem.com
sales@dristeem.com

For the most recent product information visit our website: www.dristeem.com

DRI-STEEM Corporation
a subsidiary of Research Products Corporation
DriSteem U.S. operations are ISO
9001:2015 certified

U.S. Headquarters:
14949 Technology Drive
Eden Prairie, MN 55344
800-328-4447 or 952-949-2415
952-229-3200 (fax)

European office:
Grote Hellekensstraat 54 b
B-3520 Zonhoven
Belgium
+3211823595
E-mail: dristeem-europe@dristeem.com

Continuous product improvement is a policy of DriSteem; therefore, product features and specifications are subject to change without notice.

DriSteem and Vapor-logic are registered trademarks of Research Products Corporation and are filed for trademark registration in Canada and the European community.

Product and corporate names used in this document may be trademarks or registered trademarks. They are used for explanation only without intent to infringe.

© 2018 Research Products Corporation

Form No. WMS-IOM-0818
Part No. 890000-860 Rev C

TWO-YEAR LIMITED WARRANTY

DRI-STEEM Corporation ("DriSteem") warrants to the original user that its products will be free from defects in materials and workmanship for a period of two (2) years after installation or twenty-seven (27) months from the date DriSteem ships such product, whichever date is the earlier.

If any DriSteem product is found to be defective in material or workmanship during the applicable warranty period, DriSteem's entire liability, and the purchaser's sole and exclusive remedy, shall be the repair or replacement of the defective product, or the refund of the purchase price, at DriSteem's election. DriSteem shall not be liable for any costs or expenses, whether direct or indirect, associated with the installation, removal or reinstallation of any defective product. The Limited Warranty does not include cylinder replacement for electrode steam humidifiers or media replacement for Wetted Media Systems. Excluded from the Limited Warranty are all consumable and wear and tear items such as cylinders, membranes, filters, or media replacements. These items are subject to usual wear and tear during usage.

DriSteem's Limited Warranty shall not be effective or actionable unless there is compliance with all installation and operating instructions furnished by DriSteem, or if the products have been modified or altered without the written consent of DriSteem, or if such products have been subject to accident, misuse, mishandling, tampering, negligence or improper maintenance. Any warranty claim must be submitted to DriSteem in writing within the stated warranty period. Defective parts may be required to be returned to DriSteem.

DriSteem's Limited Warranty is made in lieu of, and DriSteem disclaims all other warranties, whether express or implied, including but not limited to any IMPLIED WARRANTY OF MERCHANTABILITY, ANY IMPLIED WARRANTY OF FITNESS FOR A PARTICULAR PURPOSE, any implied warranty arising out of a course of dealing or of performance, custom or usage of trade.

DriSteem SHALL NOT, UNDER ANY CIRCUMSTANCES BE LIABLE FOR ANY DIRECT, INDIRECT, INCIDENTAL, SPECIAL OR CONSEQUENTIAL DAMAGES (INCLUDING, BUT NOT LIMITED TO, LOSS OF PROFITS, REVENUE OR BUSINESS) OR DAMAGE OR INJURY TO PERSONS OR PROPERTY IN ANY WAY RELATED TO THE MANUFACTURE OR THE USE OF ITS PRODUCTS. The exclusion applies regardless of whether such damages are sought based on breach of warranty, breach of contract, negligence, strict liability in tort, or any other legal theory, even if DriSteem has notice of the possibility of such damages.

By purchasing DriSteem's products, the purchaser agrees to the terms and conditions of this Limited Warranty.

EXTENDED WARRANTY

The original user may extend the term of the DriSteem Limited Warranty for a limited number of months past the initial applicable warranty period and term provided in the first paragraph of this Limited Warranty. All the terms and conditions of the Limited Warranty during the initial applicable warranty period and term shall apply during any extended term. An extended warranty term of an additional twelve (12) months or twenty four (24) months of coverage may be purchased. The extended warranty term may be purchased until eighteen (18) months after the product is shipped, after which time no extended warranties are available. When a DriSteem humidifier is purchased with a DriSteem RO system, an extended twenty-four (24) month coverage is included.

Any extension of the Limited Warranty under this program must be in writing, signed by DriSteem, and paid for in full by the purchaser.