

STEAM INJECTION

Humidifiers

- *For use with steam boilers*
- *Suitable for a wide range of applications*

Humidify with pressurized boiler steam

SUITABLE FOR A WIDE RANGE OF APPLICATIONS

Steam Injection humidifiers from DriSteem use steam from an external source, such as an in-house boiler or a district steam system. DriSteem's Steam Injection humidifiers are adaptable to virtually any size application, and a wide variety of models accommodate a broad range of steam absorption requirements.

STEAM JACKETED DISPERSION TUBE MODELS FOR DUCTS AND AIR HANDLERS

Single-tube, Mini-bank®, and Multi-tube humidifiers are designed for ducts and air handlers, and capable of a wide range of guaranteed non-wetting distances.

AREA-TYPE FOR OPEN SPACES

Area-type Steam Injection humidifiers are designed for open spaces such as warehouses and manufacturing spaces that do not have a duct system. The steam discharged from the humidifier is quietly dispersed by a fan without introducing water droplets into the air.



FIGURE 2-1: DRISTEEM STEAM INJECTION HUMIDIFIERS

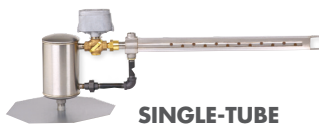

SINGLE-TUBE

Single-tube humidifiers are suitable for duct applications.

Area-type humidifiers disperse steam into open spaces using a fan.



AREA-TYPE

Mini-bank and Multiple-tube humidifiers expand ducted and AHU application flexibility with additional dispersion tubes and assembly options.

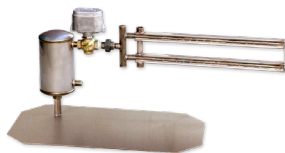

MINI-BANK

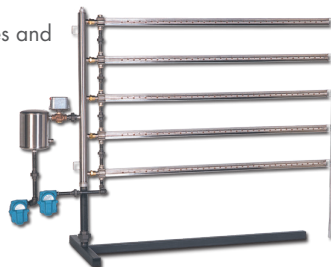

MULTIPLE-TUBE

PROVEN PERFORMANCE

- 304 stainless steel construction allows instantaneous heat-up, which minimizes condensation and eliminates cold start-up spitting.
- 304 stainless steel separator removes entrained condensate with proven centrifugal design.
- Lightweight construction requires no special supports or hangers.
- Bronze modulating steam control valves:
 - Rangeability between 13:1 and 205:1 provides enhanced controllability at minimum controllable flow.
 - Wide Cv (Kv) selection permits close matching to humidifier output capacity for precise control and no valve hunting.
 - Valves are independent from separators for easy removal.
 - Pressure drop allowance of 50 psi (345 kPa) provides control reliability at high entering steam pressure and low dispersion-side pressure.
 - Tight sealing meets ANSI Class V requirements. Ultra low steam leakage on shutoff improves system efficiency.

APPLICATION FLEXIBILITY

- Wide range of models and non-wetting distances meet virtually any humidification need.
- Numerous valve Cv (Kv) choices permit close matching to actual job requirements.
- Steam is dispersed through vertical or horizontal ducts or directly into a space.

ADDED FLEXIBILITY WITH OPTIONAL STAINLESS STEEL COMPONENTS

Single-tube, Mini-bank, and Multiple-tube humidifiers are available with options for applications requiring all stainless steel construction.

- Stainless steel components reduce corrosion potential and are compatible with steam derived from DI/RO water.
- Modulating electric and pneumatic stainless steel valves are manufactured to precise tolerances, with some configurations capable of achieving the highest turndown ratio in the industry.
- Stainless steel component options:
 - 316 stainless steel separator and dispersion tubes
 - Stainless steel steam control valves
 - 304 or 316 stainless steel interconnecting piping
 - Stainless steel strainers and thermostatic traps

GUARANTEED ABSORPTION

- Cataloged and guaranteed steam absorption (non-wetting) distances
- Steam-jacketed dispersion tubes are fitted with calibrated tubelets ensure uniform steam dispersion across the duct
- Thermal-resin tubelets have exceptional ability to trap noise generated by the valve
- Published absorption tables for sizing and selecting the correct humidifier
- DriSteem's Dri-calc[®] software is available for computer calculation of non-wetting distances and system selection



Steam injection humidifiers

FIGURE 4-1: STEAM INJECTION HUMIDIFIER MODELS



SINGLE-TUBE HUMIDIFIER

- Suitable for small- to medium-capacity systems, 1.5–525 lbs/hr (0.7–238 kg/h)
- Moderate to long non-wetting distance
- Pre-assembled separator/tube assembly
- See Pages 7-11

All Steam Injection humidifiers show here, except Area-type, are available with options for applications requiring all stainless steel construction.



MINI-BANK HUMIDIFIER

- Suitable for small-capacity systems, 1.6–84 lbs/hr (0.7–38 kg/h)
- Short to moderate non-wetting distance
- Sized for small ducts
- Pre-engineered and pre-assembled header/tube assembly, ready for mounting and hookup
- See Pages 12-15



MULTIPLE-TUBE HUMIDIFIER

- Suitable for small- to large-capacity systems, 6.5–3989 lbs/hr (2.3–1809 kg/h)
- Sizes to fit small ducts and large air handlers
- Short to moderate non-wetting distance
- Field assembled (with interconnecting piping and header supplied by contractor)
- Maxi-bank™ option:
 - Pre-assembled, except when either dimension is 98 inches (2490 mm) or more
 - Includes 304 stainless steel header, with option for 316 stainless steel
 - Includes black iron piping, with options for 304 or 316 stainless steel
- See Pages 16-22



AREA-TYPE HUMIDIFIER

- Suitable for medium-capacity systems, 1.8–286 lbs/hr (0.8–130 kg/h)
- Used in open spaces
- Application-dependent non-wetting distances
- See Pages 23-25

mc_033111_0500

FIGURE 5-1: STEAM INJECTION HUMIDIFIER COMPONENTS

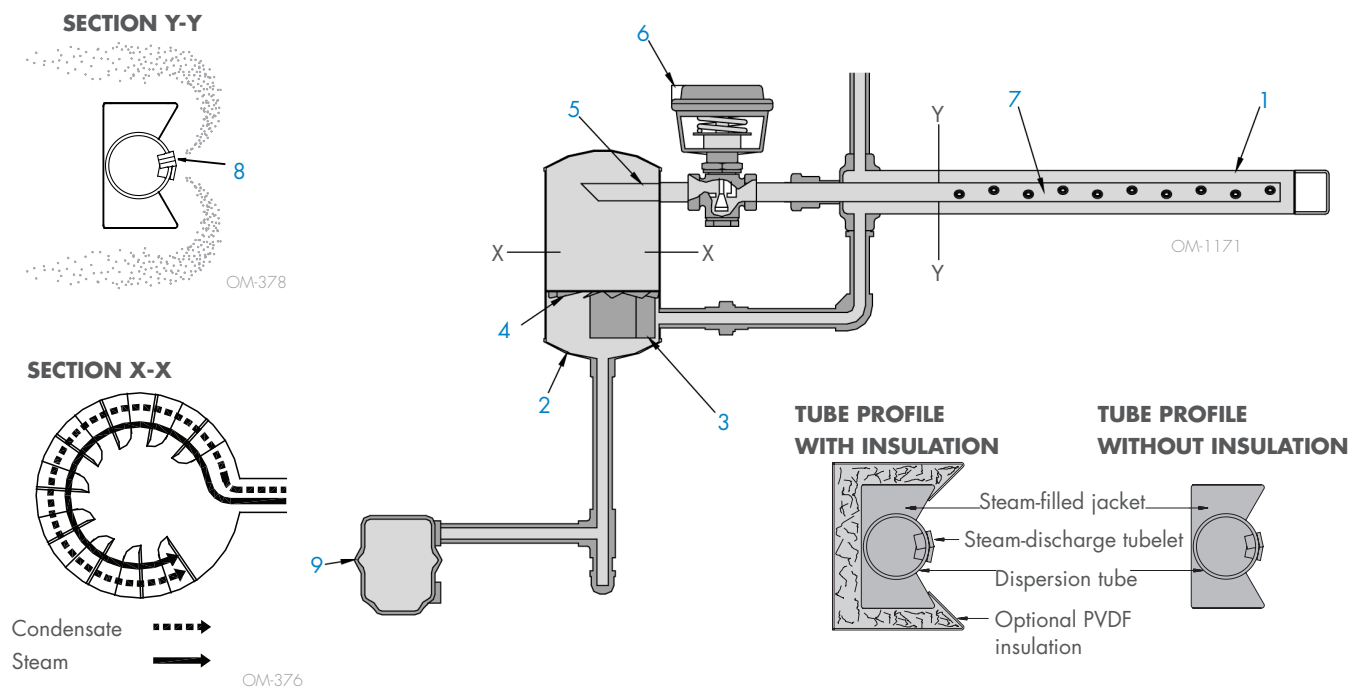

1 Steam jacket

A chamber that jackets the inner dispersion tube with hot steam to eliminate condensation and dripping

2 Steam separator

Separates steam from condensate

3 Deflector plate

Inside the steam separator, deflects condensate into a circular pattern and toward the drain

4 Multi-baffle plate

Allows only steam to rise into the upper region of the separator

5 Internal drying tube

Excludes any remaining condensate, allowing only dry steam to leave the separator

6 Steam valve

Controls the amount of steam allowed into the dispersion tube

7 Dispersion tube

Provides uniform steam dispersion across the duct width

8 Thermal-resin tubelet

Unique tubelets extend into the dispersion tube center so only the hottest, driest steam is discharged into the air. These tubelets also have an exceptional ability to trap noise generated by the valve, making DriSteem's Steam Injection humidifiers the quietest in the industry.

9 Steam trap

Allows only condensate to pass to the condensate return system

See Figure 6-1 for a description of how these components operate together.

mc_031611_0805

FIGURE 6-1: STEAM INJECTION HUMIDIFIER PRINCIPLE OF OPERATION

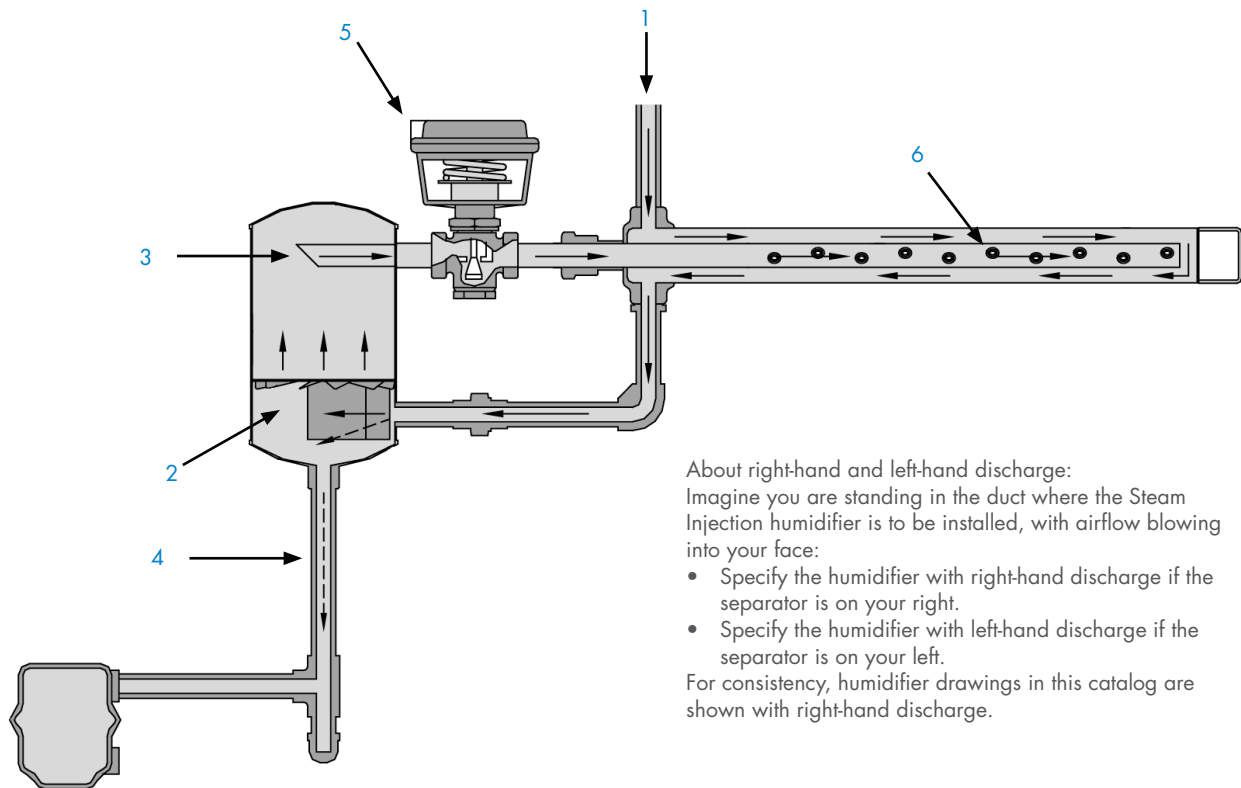

About right-hand and left-hand discharge:
Imagine you are standing in the duct where the Steam Injection humidifier is to be installed, with airflow blowing into your face:

- Specify the humidifier with right-hand discharge if the separator is on your right.
- Specify the humidifier with left-hand discharge if the separator is on your left.

For consistency, humidifier drawings in this catalog are shown with right-hand discharge.

- 1 Boiler steam enters the humidifier at line pressure and flows through a chamber (jacket) surrounding an inner dispersion tube. The jacket of steam preheats the dispersion tube so that when steam enters the dispersion tube (at Step 5 below) it does not condense as it would if the tube were cold, thereby eliminating condensation and dripping.
- 2 After flowing through the steam jacket, steam with entrained condensate slows from entering the larger space of the separator and from hitting the perimeter deflector plate, and begins to spin and separate.
- 3 Separated steam rises through slots in the multi-baffle plate to the separator upper region, and enters the internal drying tube that excludes any remaining condensate, allowing only dry steam to leave the separator.
- 4 Separated condensate drains from the separator to the steam trap.
- 5 The steam valve controls the amount of steam allowed into the preheated dispersion tube. The steam valve is typically controlled in one of two ways:
 - By a signal from a building automation system
 - By a humidity controller connected to the steam valve
- 6 Steam is discharged uniformly through the tubelets into the airstream.

mc_031611_0808

OM-1170

Single-tube humidifiers are preassembled and suitable for small-capacity applications where available non-wetting distance is not critical.

See "Added flexibility with optional stainless steel components" at the bottom of Page 3.

FIGURE 7-1: SINGLE-TUBE HUMIDIFIER

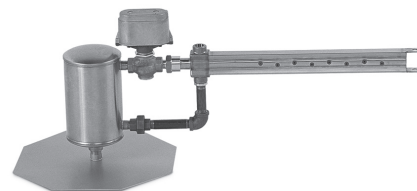

Table 7-1:
Single-tube humidifier standard dispersion tube face lengths

Table model	Face lengths
60	6" to 144" in 1/2" increments (150 mm to 3658 mm in 13-mm increments)
70	18" to 192" in 1/2" increments (457 mm to 4877 mm in 13-mm increments)
80	24" to 192" in 1/2" increments (610 mm to 4877 mm in 13-mm increments)

Notes:

- See dimension drawing in Figure 8-1.
- End support brackets are provided only on tube lengths of 12" (305 mm) or longer.

Table 7-2:
Single-tube humidifier shipping weights

Separator*			Tube		
size	lbs	kg	no.	Weight/ft	
				lbs	kg
5	24.0	10.9	60	2.6	1.2
6	32.0	14.5	70	2.8	1.3
7	32.5	14.7	70	2.8	1.3
8	52.5	23.8	80	3.0	1.4

* Includes control valve, drain trap, and strainer

Table 7-3:
Single-tube humidifier dispersion tube capacities

Face length		Model 60 tubes		Model 70 tubes		Model 80 tubes	
inches	mm	lbs/hr	kg/h	lbs/hr	kg/h	lbs/hr	kg/h
<24	<610	consult factory		consult factory		—	—
24 to 36	610 to 890	up to 180	up to 81	up to 180	up to 81	up to 350	up to 159
37 to 48	915 to 1220	180	81	up to 210	up to 95	up to 450	up to 204
>48	>1220	180	81	250	113	525	238

Single-tube humidifier dimensions

FIGURE 8-1: SINGLE-TUBE HUMIDIFIER DIMENSIONS

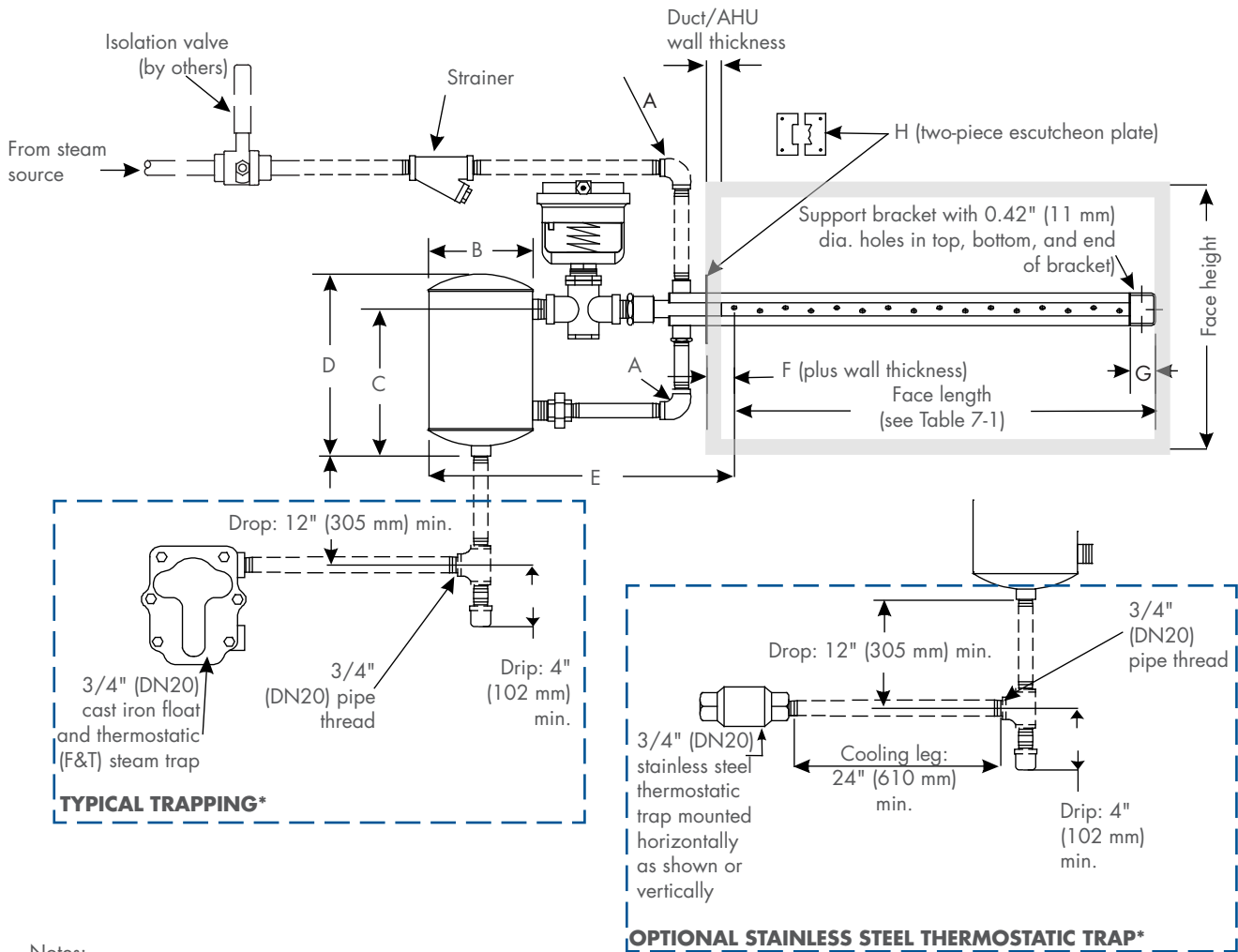

Notes:

- * See Pages 26 and 27, and see Note 5 in Figure 10-1 for more information about traps and trap piping.
- Dashed lines indicate provided by installer; right-hand discharge shown.
- Typical installation shown; see additional installation configurations in *Steam Injection Humidifiers Installation, Operation, and Maintenance Manual*.

mc_041411_1225

OM-565X

Single-tube humidifier dimensions and weights

**Table 9-1:
Single-tube humidifier dimensions**

Model	Valve size		A		B		C		D		E		F*		G		H	
	inches	DN	inches	DN	inches	DN	inches	DN	inches	DN	inches	DN	inches	DN	inches	DN	inches	DN
5-60	1/2	15	1/2	15	5	127	8.00	203	9.75	248	13.5	343	2	51	1.5	40	4x4	100x100
6-60	1/2	15	1/2	15	6	152	8.25	210	10.50	267	15.0	381	2	51	1.5	40	4x4	100x100
6-70	1/2	15	3/4	20	6	152	8.25	210	10.50	267	16.5	419	2	51	1.5	40	4x4	100x100
7-60	3/4	20	1/2	15	7	178	8.50	222	11.00	279	16.5	419	2	51	1.5	40	4x4	100x100
7-60	1	30	1/2	15	7	178	8.50	222	11.00	279	17.5	445	2	51	1.5	40	4x4	100x100
7-70	3/4	20	3/4	20	7	178	8.50	222	11.00	279	18.0	457	2	51	1.5	40	4x4	100x100
7-70	1	30	3/4	20	7	178	8.50	222	11.00	279	19.0	483	2	51	1.5	40	4x4	100x100
8-80	3/4	20	1½	40	8	203	10.50	273	13.75	349	19.5	495	2	51	1.5	40	6x6	152x152
8-80	1	30	1½	40	8	203	10.50	273	13.75	349	20.5	521	2	51	1.5	40	6x6	152x152
8-80	1¼	35	1½	40	8	203	10.50	273	13.75	349	20.0	508	2	51	1.5	40	6x6	152x152
8-80	1½	35	1½	40	8	203	10.50	273	13.75	349	21.0	533	2	51	1.5	40	6x6	152x152

* Variable from 0" to 2" (0 mm to 51 mm) in addition to duct/AHU wall thickness.

mc_041411_1226

Single-tube humidifier field piping example

FIGURE 10-1: SINGLE HORIZONTAL DISPERSION TUBE HUMIDIFIER INSTALLED IN A DUCT WITH HORIZONTAL AIRFLOW

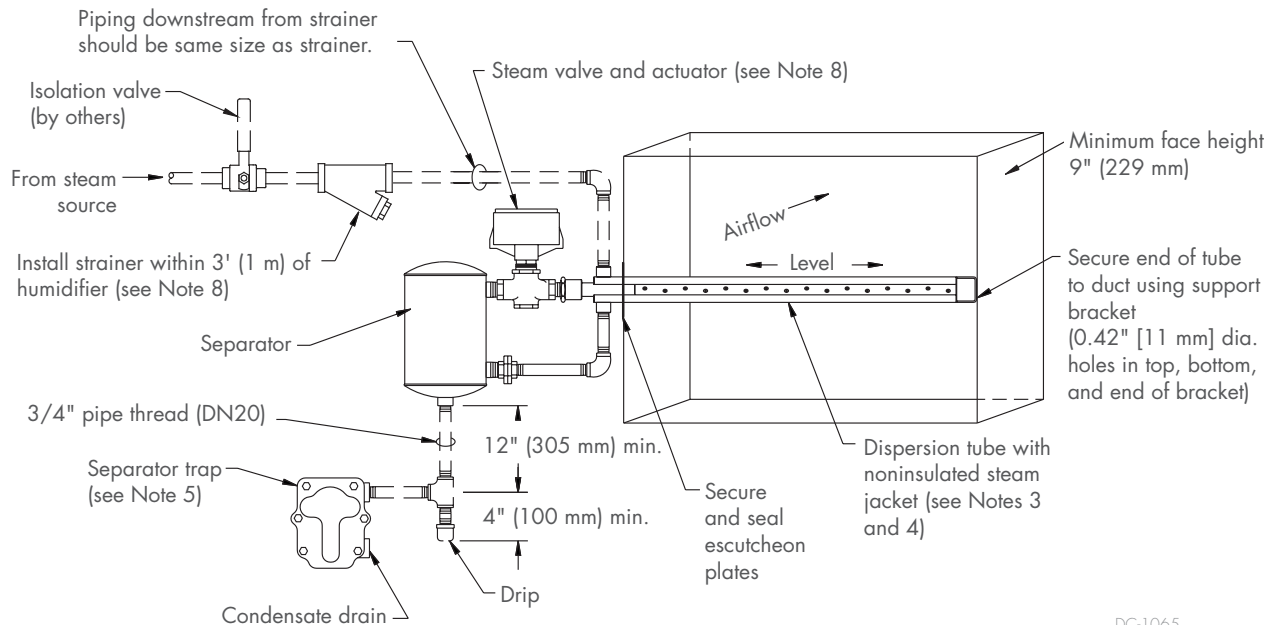

DC-1065

Notes:

- To avoid metal fatigue, allow for dispersion tube thermal expansion.
- Dashed lines indicate provided by installer; right-hand discharge shown.
- Horizontal airflow (shown):
Slightly better mixing with less visible vapor travel occurs when discharged steam blows against the airflow, rather than with the airflow. When using noninsulated steam jackets in a horizontal airflow (as shown above), position tubelets (steam orifices) so they face into the airflow. However, if the dispersion tube has an insulated jacket, the discharged steam must blow with the airflow to avoid condensation that may occur when discharged steam contacts the cooler insulated jacket. When using insulated steam jackets in a horizontal airflow, position tubelets so they discharge steam with the airflow, and add 24" (610 mm) to the non-wetting distance.

Vertical airflow:

- Always position tubelets pointing up when installing in a vertical airflow.
If steam jackets are insulated, install humidifier only in a vertical upflow application, and add 24" (610 mm) to the non-wetting distance.
Do not install insulated jackets in a vertical downflow application.
- Center tube within face height.
 - If steam pressure is less than or equal to 15 psi (103.4 kPa), use a float and thermostatic (F&T) trap for the humidifier.
If steam pressure is greater than 15 psi (103.4 kPa), use an inverted bucket trap for the humidifier.
If lifting condensate, use an inverted bucket trap and check valve regardless of steam pressure. Inverted bucket traps may require priming after seasonal shutdown.

Models with optional stainless steel components:

Use stainless steel thermostatic traps and stainless steel piping. Provide a 12" (305 mm) minimum drop plus a cooling leg at least 24" (610 mm) long before the trap as shown in Figure 8-1.

All models and trap types:

During consistent load, there may not be enough pressure in the separator trap to lift condensate from the separator.

- See condensate drain piping and trapping information on Pages 26 and 27.
- See the Dri-calc Installation Guide library and/or the *Steam Injection Humidifiers Installation, Operation, and Maintenance Manual* (available at www.drasteem.com) for more installation instructions. Dri-calc is DriSteem's free sizing and selection software; see Dri-Calc on www.drasteem.com.
- Steam valve and strainer sizes are provided by Dri-calc (Note 7). You may also contact your DriSteem representative for valve and strainer sizing, or access the steam valve and strainer calculator on www.drasteem.com.

FIGURE 11-1: SINGLE-TUBE HUMIDIFIER NON-WETTING DISTANCES

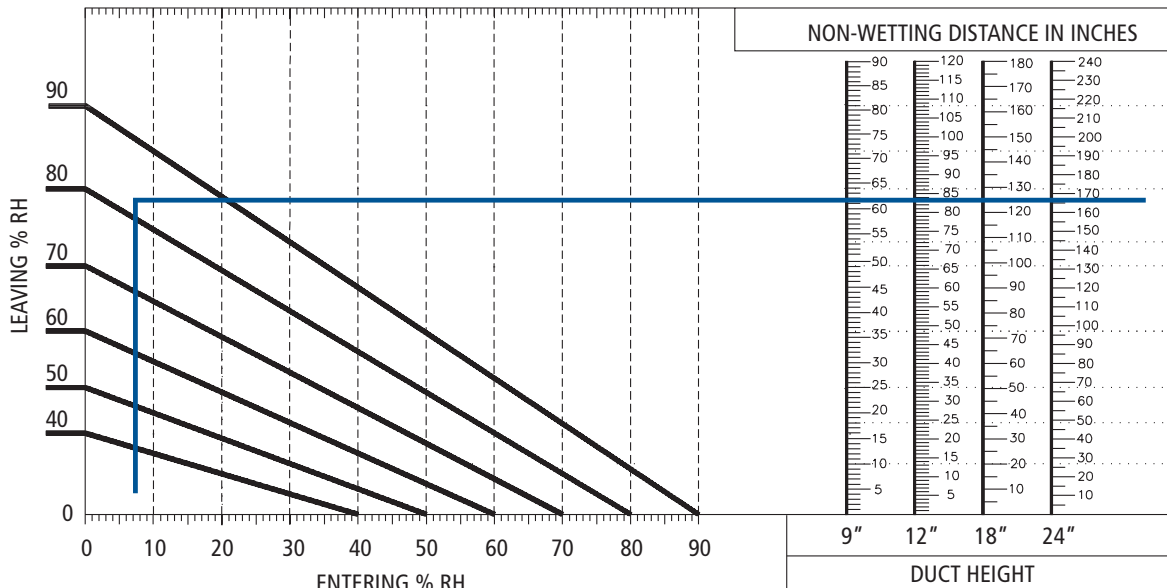

Notes:

- The above data apply to all air velocities up to 1,500 fpm (7.6 m/s), and are based on air leaving the zone of humidification at conditions of 55 °F (13 °C) and the stated % RH. The blue lines in the graph refer to the sample exercise described below.
- Add 24" (610 mm) to the non-wetting distance when using insulated jackets.

PROVEN PERFORMANCE

Assume the air entering the humidifier is 5% RH, the air leaving the zone of humidification needs to be 80% RH, and the duct height is 18" (457 mm).

The blue lines in Figure 11-1 are provided for this exercise:

To determine the non-wetting distance for a Single-tube humidifier and the conditions above, enter the non-wetting distances graph at the Entering RH of 5%. Proceed vertically to intersect the 80% Leaving RH slope, then read horizontally to the right to intersect the Duct height column for an 18" (457 mm) duct. The non-wetting distance is approximately 120" (3050 mm).

Important notes

- Final equipment selection should account for condensate loss. See the *DriSteem Design Guide* for steam loss tables.
- See the *DriSteem Design Guide* for humidification load calculation instructions. The Design Guide can be viewed, printed, or ordered at www.dristeem.com.
- Use Dri-calc, DriSteem's free sizing and selection software for calculating load, determining non-wetting distance, and selecting equipment. See Dri-calc on www.dristeem.com.
- See "Steam absorption considerations" on Page 15.

Mini-bank humidifier

The Mini-bank humidifier is designed for use in small ducts. It is a pre-engineered and pre-assembled header/tube assembly, ready for mounting and hookup.

Slimline dispersion tubes with laboratory-tested, optimum tube spacing promote rapid steam absorption without excessive static pressure loss or heat gain.

Precision orifices spaced 1" (25 mm) apart ensure proportional steam dispersion along the entire tube length.

See "Added flexibility with optional stainless steel components" at the bottom of Page 3.

FIGURE 12-1: MINI-BANK HUMIDIFIER

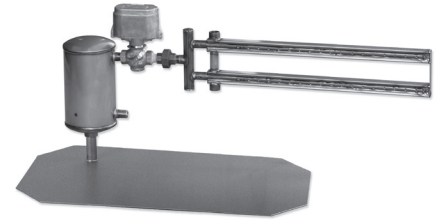
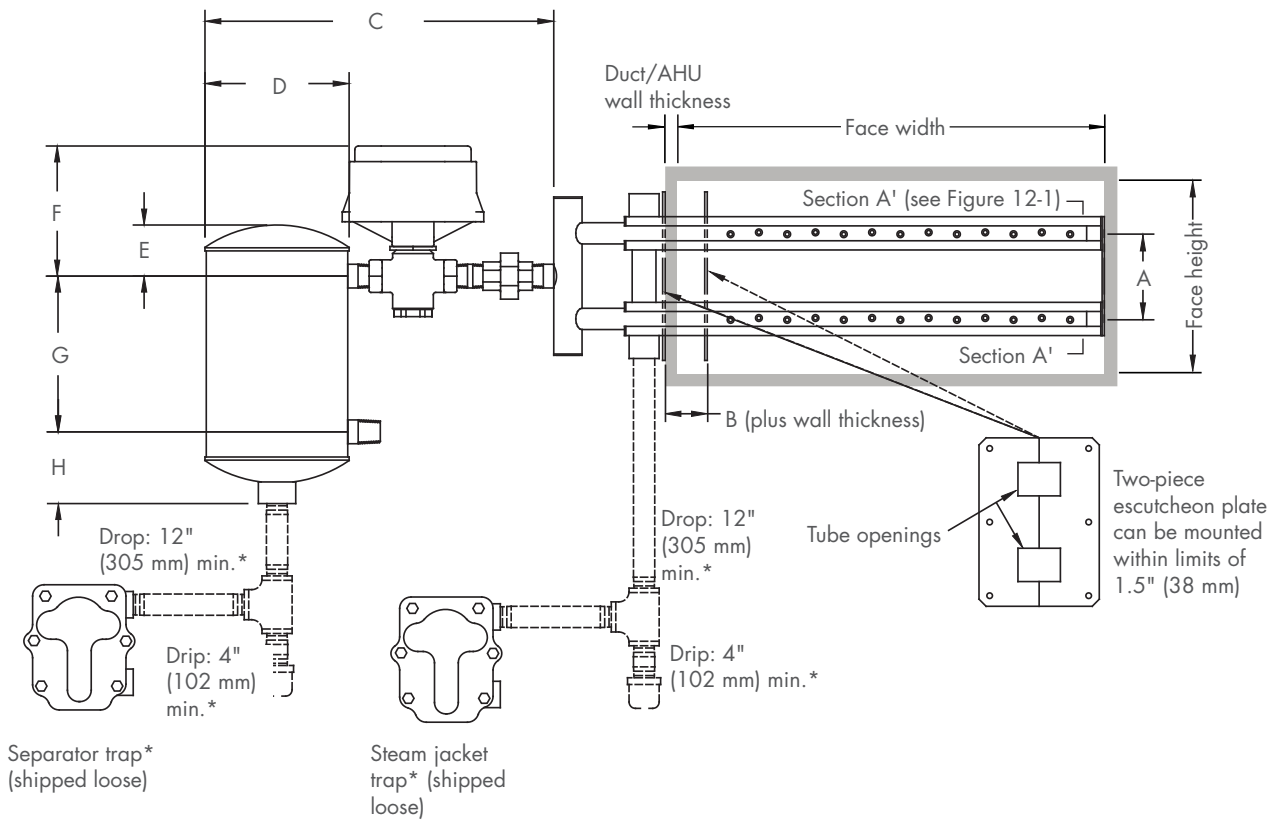

FIGURE 12-2: MINI-BANK HUMIDIFIER DIMENSIONS



Notes:

- * See Pages 26 and 27, and see Note 5 in Figure 14-1 for more information about trap types and piping.
- Dashed lines indicate provided by installer; right-hand discharge shown.

Mini-bank humidifier dimensions and specifications

Table 13-1:
Mini-bank humidifier specifications

Face height		Required number of tubes	Face width	Shipping weights
inches	mm			
6-9	150-230	2	6" to 48" in 1/2" increments (150 mm to 1220 mm in 13-mm increments)	Tubes: 0.3 lbs per tube foot (0.4 kg per tube meter)
10-12	250-305	3		
13-15	330-380	4		
16-18	405-460	5		
19-21	480-535	6		
22-24	560-610	7		

For face dimensions larger than 48" x 24" (w x h) (1220 mm x 610 mm), use Multiple-tube humidifier.

Remaining components (separator, valve, traps, etc.): 8.5 lbs (3.8 kg)

Note: See Figure 12-1 for face height and face width.

mc_032213_1034

Table 13-2:
Mini-bank humidifier air pressure loss

Air velocity		Static pressure loss			
inches	mm	Inches wc		Pa	
		Insulated	Noninsulated	Insulated	Noninsulated
500	2.5	0.04	0.020	9.95	4.98
750	3.8	0.07	0.040	17.42	9.95
1000	5.1	0.13	0.075	32.35	18.66

mc_031611_1145

Table 13-3:
Mini-bank humidifier dimensions

	A	B	C	D	E	F	G	H
inches	3.00	1.50	12.50	5.00	1.75	6.50	5.50	250
mm	76	38	318	127	45	165	140	64

mc_081208_0740

FIGURE 13-1:
VIEW A' TO A' FROM FIGURE 12-1

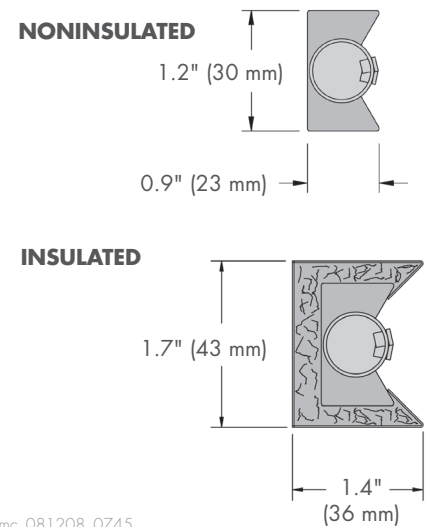

mc_081208_0745

Mini-bank humidifier field piping example

FIGURE 14-1: MINI-BANK HUMIDIFIER INSTALLED IN A DUCT WITH HORIZONTAL AIRFLOW

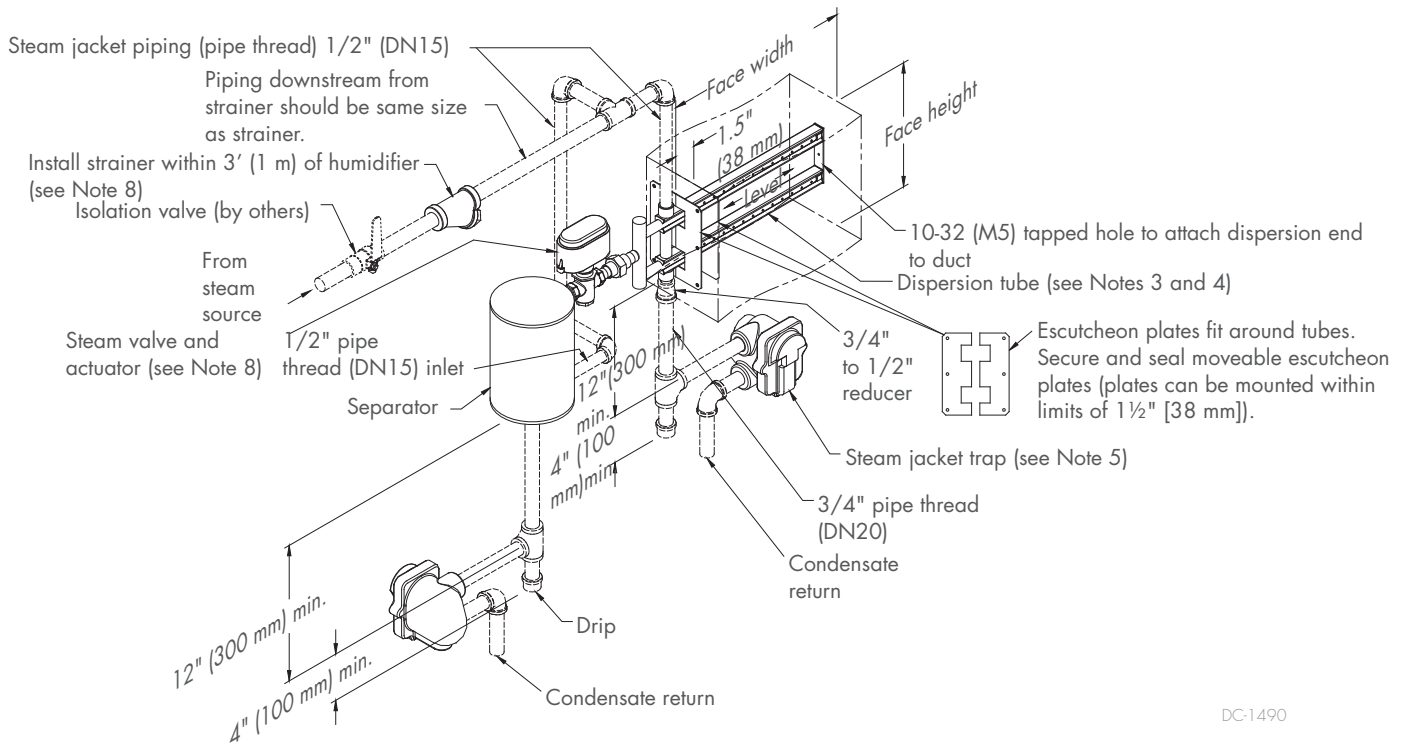

DC-1490

Notes:

1. To avoid metal fatigue, allow for dispersion tube thermal expansion.
2. Dashed lines indicate provided by installer; right-hand discharge shown.
3. Horizontal airflow (shown):

Slightly better mixing, with less visible vapor travel, occurs when discharged steam blows against the airflow rather than with the airflow. Therefore, when using noninsulated steam jackets in a horizontal airflow (as shown above), position dispersion tubelets (steam orifices) so they face into the airflow.

However, if the dispersion tube has an insulated jacket, the discharged steam must blow with the airflow to avoid condensation that may occur when discharged steam contacts the cooler insulated jacket. When using insulated steam jackets in a horizontal airflow, position dispersion tubelets so they discharge steam with the airflow, and add 24" (610 mm) to the non-wetting distance.

Vertical airflow:

Always position tubelets (steam orifices) pointing up when installing in a vertical airflow.

If steam jackets are insulated, install humidifier only in a vertical upflow application, and add 24" (610 mm) to the non-wetting distance. Do not install insulated jackets in a vertical downflow application.

4. Center tube assembly within face height.
5. For steam pressure less than or equal to 15 psi (103.4 kPa), use a float and thermostatic (F&T) trap for the humidifier.

If lifting condensate, use an inverted bucket trap and check valve regardless of steam pressure. Inverted bucket traps may require priming after seasonal shutdown.

During consistent load, there may not be enough pressure in the separator trap to lift condensate from the separator.

Models with optional stainless steel components:

Use only stainless steel thermostatic traps and stainless steel piping. Provide a 12" (305 mm) minimum drop to trap plus a 24" (610 mm) minimum cooling leg before the trap, as shown in Figure 8-1.

6. See condensate drain piping and trapping information on Pages 26 and 27.
7. See the Dri-calc Installation Guide library and/or the *Steam Injection Humidifiers Installation, Operation, and Maintenance Manual* (available at www.drirsteem.com) for more installation instructions. Dri-calc is DriSteem's free sizing and selection software; see Dri-calc on www.drirsteem.com.
8. Steam valve and strainer sizes are provided by Dri-calc (Note 7). You may also contact your DriSteem representative for valve and strainer sizing, or access the steam valve and strainer calculator on www.drirsteem.com.

FIGURE 15-1: MINI-BANK HUMIDIFIER NON-WETTING DISTANCES

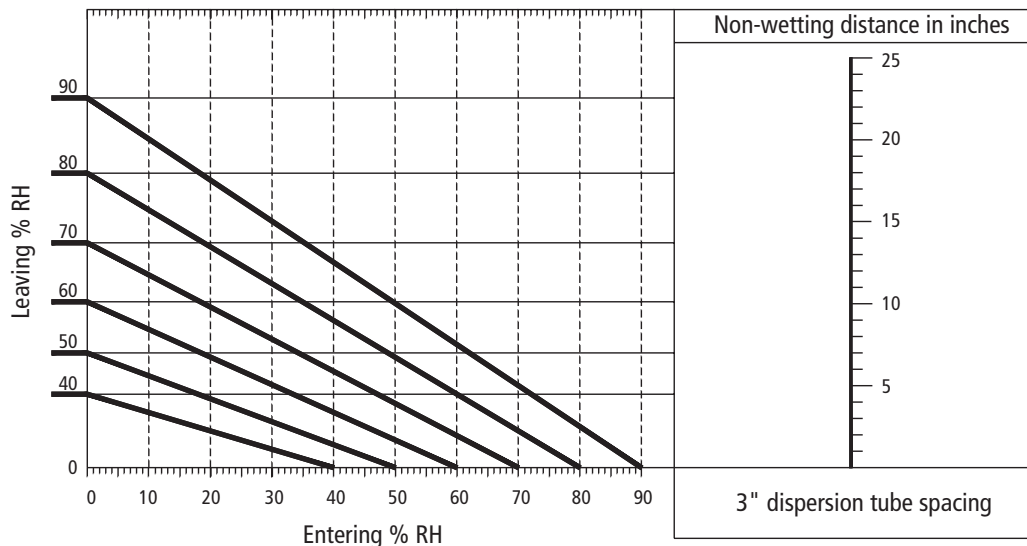

Notes:

- The above data apply to all air velocities up to 1,500 fpm (7.6 m/s) and are based on air leaving the zone of humidification at conditions of 55 °F (13 °C) and the stated % RH.
- Add 24" (610 mm) to the non-wetting distance when using insulated jackets.

STEAM ABSORPTION CONSIDERATION

1. Non-wetting distance is the dimension downstream from the humidifier to the point where wetting will not occur, although steam wisps may be present. Solid objects at duct air temperature, such as coils, dampers, fans, etc., downstream from this dimension will remain dry.
2. **CAUTION!** Non-wetting distances described in this catalog do not apply when installing a Steam Injection humidifier upstream from filter media. If you need to install a Steam Injection humidifier upstream from filter media, consult your representative or DriSteem directly for special recommendations.
3. Note that the rise (Δ) in RH (the difference between entering and leaving RH) has a direct bearing on the non-wetting distance. As the rise increases, more vapor needs to be dispersed into the air, which increases the non-wetting distance.
4. Uneven airflow over the dispersion assembly's cross-section can result in nonuniform steam-and-air mixing, which increases the non-wetting distance.

Determining non-wetting distance

See Page 11 for important notes and for instructions on using the graph above to determine non-wetting distance.

Multiple-tube humidifier

Multi-tube humidifiers are best suited for large-capacity applications with short to moderate non-wetting distance requirements. Multiple-tube humidifiers disperse steam evenly across an entire duct width and height. Multiple-tube humidifier components are shipped loose for on-site assembly. All header and interconnecting piping is supplied by the contractor.

The Maxi-bank option (see Figure 21-1) features a stainless steel header and black iron interconnecting piping; it ships completely assembled and ready for installation, except when either dimensions is 98 inches (2490 mm) or more.

See "Added flexibility with optional stainless steel components" at the bottom of Page 3.

FIGURE 16-1: MULTIPLE-TUBE HUMIDIFIER WITH MAXI-BANK OPTION



FIGURE 16-2: MULTIPLE-TUBE HUMIDIFIER

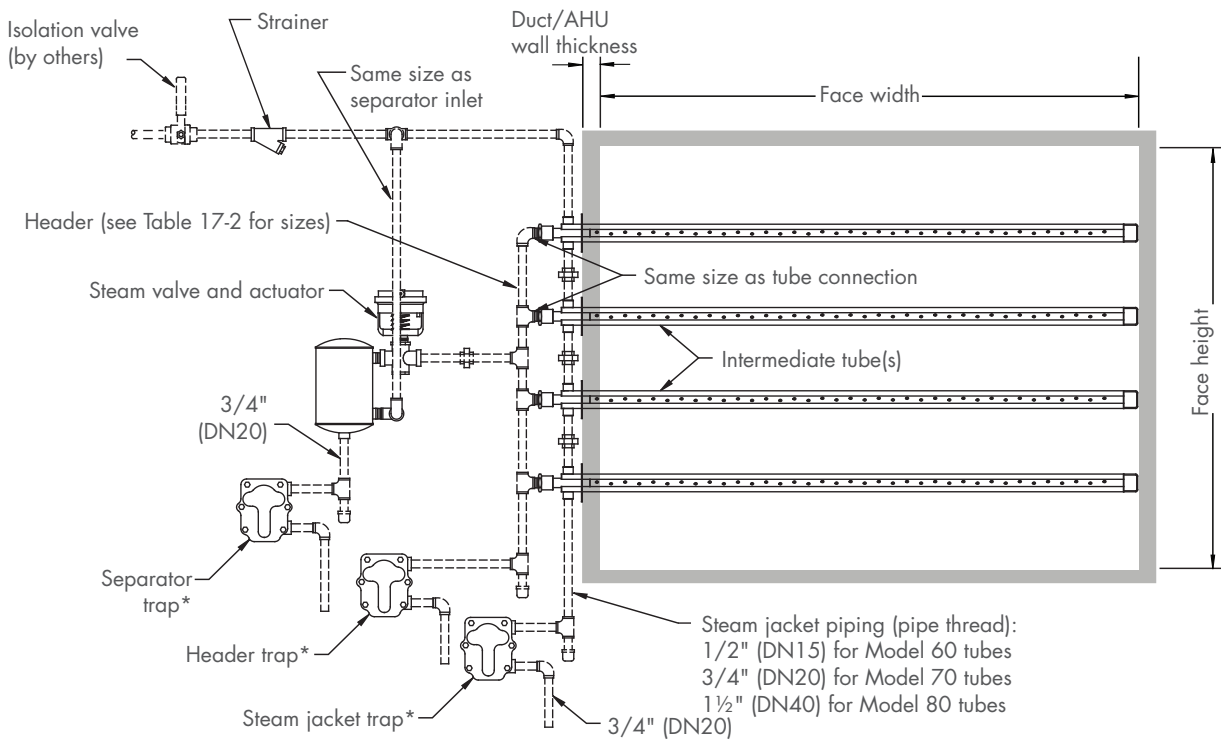

Notes:

- * See Pages 26 and 27, and see Note 4 on Page 19 for more information about trap types and piping.
- See Note 1 on Page 19 for dispersion tube positioning.
- Tubes should span at least 90% of coil or airstream width.
- Dashed lines indicate provided by installer (see Maxi-bank option in Figure 21-1). Right-hand discharge shown.

Multiple-tube humidifier dimensions and specifications

Table 17-1:
Multiple-tube humidifier minimum tube spacing

Tube model	Minimum tube spacing (X*) Multiple-tube humidifier		Minimum tube spacing (X*) Multiple-tube humidifier with optional stainless steel piping	
	inches	mm	inches	mm
60	6	152	8	229
70	9	229	9	229
80	9	229	12	305

* See Figures 20-1 and 21-1 for center-to-center distance X.

mc_040710_1030

Table 17-2:
Multiple-tube humidifier header sizes

Total capacity		Header size	
lbs/hr	kg/h	inches	DN
up to 280	up to 127	1.5*	38*
up to 490	up to 222	2.0	50
491 to 980	223 to 444	3.0	80
981 to 1743	445 to 790	4.0	100
1744 to 2752	791 to 1248	5.0	125
2753 to 3989	1249 to 1809	6.0	150

* Non Maxi-bank only

mc_040710_1005

FIGURE 17-1: MULTIPLE-TUBE HUMIDIFIER DISPERSION TUBE DIMENSIONS

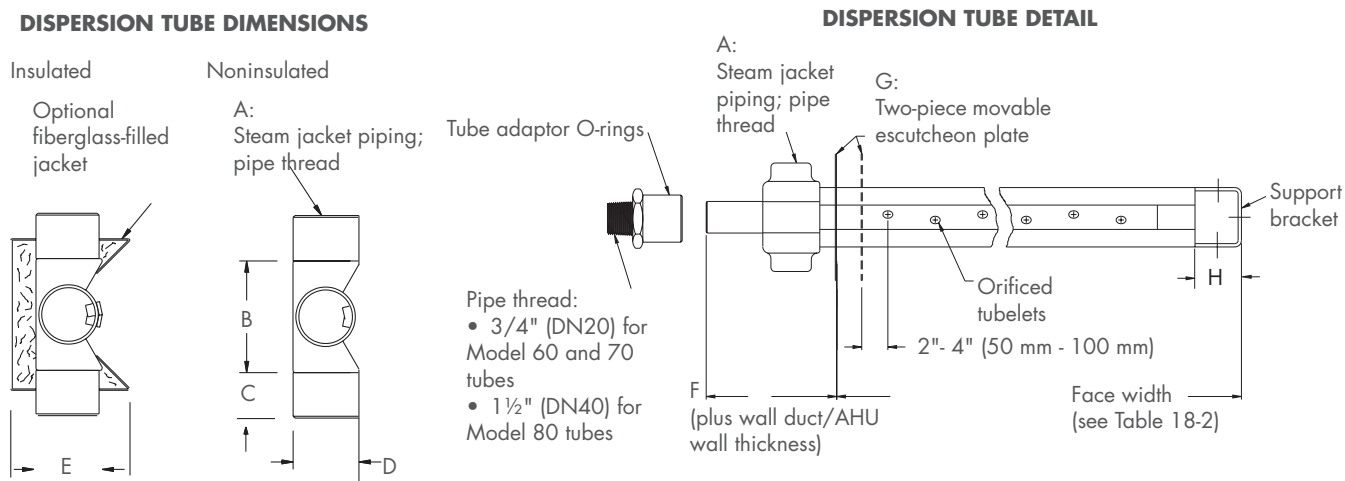

Note: See dimensions in Table 17-3.

375lw and OM:388AB

Table 17-3:
Single-tube humidifier dimensions

Tube model	A		B		C		D		E		F*		G		H	
	inches	DN	inches	mm	inches	mm	inches	mm	inches	mm	inches	mm	inches	mm	inches	mm
60	1/2	15	1.88	48	0.81	21	1.13	29	2.0	51	4.0	102	4x4	102x102	1.5	38
70	3/4	20	2.63	67	0.81	21	1.88	48	3.0	76	4.0	102	4x4	102x102	1.5	38
80	1 1/2	40	3.00	76	1.06	27	2.50	64	3.5	89	5.5	140	6x6	152x152	1.5	38

Multiple-tube humidifier dimensions and specifications

FIGURE 18-1: MULTIPLE-TUBE HUMIDIFIER SEPARATOR DIMENSIONS

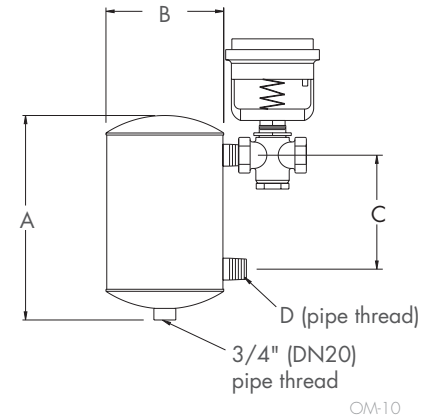

**Table 18-1:
Multiple-tube humidifier separator dimensions and weights**

Separator size	A		B		C		D		Shipping weight*	
	inches	DN	inches	mm	inches	mm	inches	DN	lbs	kg
5	9.75	248	5.0	127	5.50	140	1/2	15	9	4.1
6	10.50	267	6.0	152	5.38	137	3/4	20	21	9.5
7	11.00	279	7.0	178	5.50	140	3/4	20	24	10.9
8	13.75	349	8.0	203	6.88	175	1 1/2	40	43	19.5
9	14.25	362	9.0	229	7.00	178	2	50	52	23.6

* Includes control valve, drain trap, and strainer.

**Table 18-2:
Multiple-tube humidifier dispersion tube face widths and tube weights**

Tube model	Tube weight per 12" (305 mm)		Face lengths
	lbs	kg	
60	0.75	0.34	6" to 144" in 1/2" increments (150 mm to 3658 mm in 13-mm increments)
70	1.00	0.45	18" to 192" in 1/2" increments (457 mm to 4877 mm in 13-mm increments)
80	1.50	0.68	24" to 192" in 1/2" increments (610 mm to 4877 mm in 13-mm increments)

Notes:

- See face widths in Figure 16-2.
- For face widths not listed, consult factory.

**Table 18-3:
Multiple-tube humidifier dispersion tube capacities**

Face width		Model 60 and 70 tubes		Model 80 tubes	
inches	mm	lbs/hr	kg/h	lbs	kg/h
<24	<610	consult factory		—	—
24 to 36	610 to 890	up to 180	up to 81	up to 350	up to 159
37 to 48	915 to 1220	up to 210	up to 95	up to 450	up to 204
>48	>1220	250	113	525	238

NOTES FOR FIGURES 16-2, 20-1, AND 21-1

1. Horizontal airflow (shown)

Slightly better mixing with less visible vapor travel occurs when discharged steam blows against the airflow, rather than with the airflow. **When using noninsulated steam jackets in a horizontal airflow** (as shown in the drawings), position dispersion tubelets (steam orifices) so they face into the airflow. However, if the dispersion tube has an insulated jacket, the discharged steam must blow with the airflow to avoid condensation that may occur when discharged steam contacts the cooler insulated jacket. **When using insulated steam jackets in a horizontal airflow**, position dispersion tubelets so they discharge steam with the airflow, and add 24" (610 mm) to the non-wetting distance.

Vertical airflow

Always position tubelets (steam orifices) pointing up when installing in a vertical airflow. If steam jackets are insulated, install humidifier only in a vertical upflow application and add 24" (610 mm) to the non-wetting distance. **Do not install insulated jackets in a vertical downflow application.**

2. Jacket piping size:
 - 1/2" pipe thread (DN15) for Model 60 tubes
 - 3/4" pipe thread (DN20) for Model 70 tubes
 - 1 1/2" pipe thread (DN40) for Model 80 tubes
3. After humidifier is installed, secure steam jacket piping to tube header.
4. If steam pressure is less than or equal to 15 psi (103.4 kPa), use float and thermostatic (F&T) traps for the humidifier. If steam pressure is greater than 15 psi (103.4 kPa), use inverted bucket traps for the humidifier. If lifting condensate, use an inverted bucket trap and check valve regardless of steam pressure. Inverted bucket traps may require priming after seasonal shutdown.

During consistent load, there may not be enough pressure in the separator trap to lift condensate from the separator.

Models with optional stainless steel components:

Use only stainless steel thermostatic traps and stainless steel piping. Provide a 12" (305 mm) minimum drop to trap plus a 24" (610 mm) minimum cooling leg before the trap as shown on Pages 26 and 27.

5. Due to the pressure drop across the valve, the steam pressure at the header trap is minimal; therefore, you cannot lift condensate or return condensate to a pressurized return by steam pressure from this trap. On small headers (2" [DN50] or less in diameter), this trap may be omitted.
6. See "Condensate drain piping and trapping" on Pages 26 and 27.

See Figure 21-1 for Multiple-tube humidifier with Maxi-bank option.
See the Dri-calc Installation guide library and/or the Steam Injection Humidifiers Installation, Operation, and Maintenance manual (available at www.dristeem.com) for more installation instructions.
Dri-calc is DriSteem's free sizing and selection software; see Dri-calc on www.dristeem.com.

Multiple-tube humidifier field piping examples

FIGURE 20-1: MULTIPLE-TUBE HUMIDIFIER WITH TOTAL TUBE LENGTH GREATER THAN 45' (13.7 M) IN AN AHU

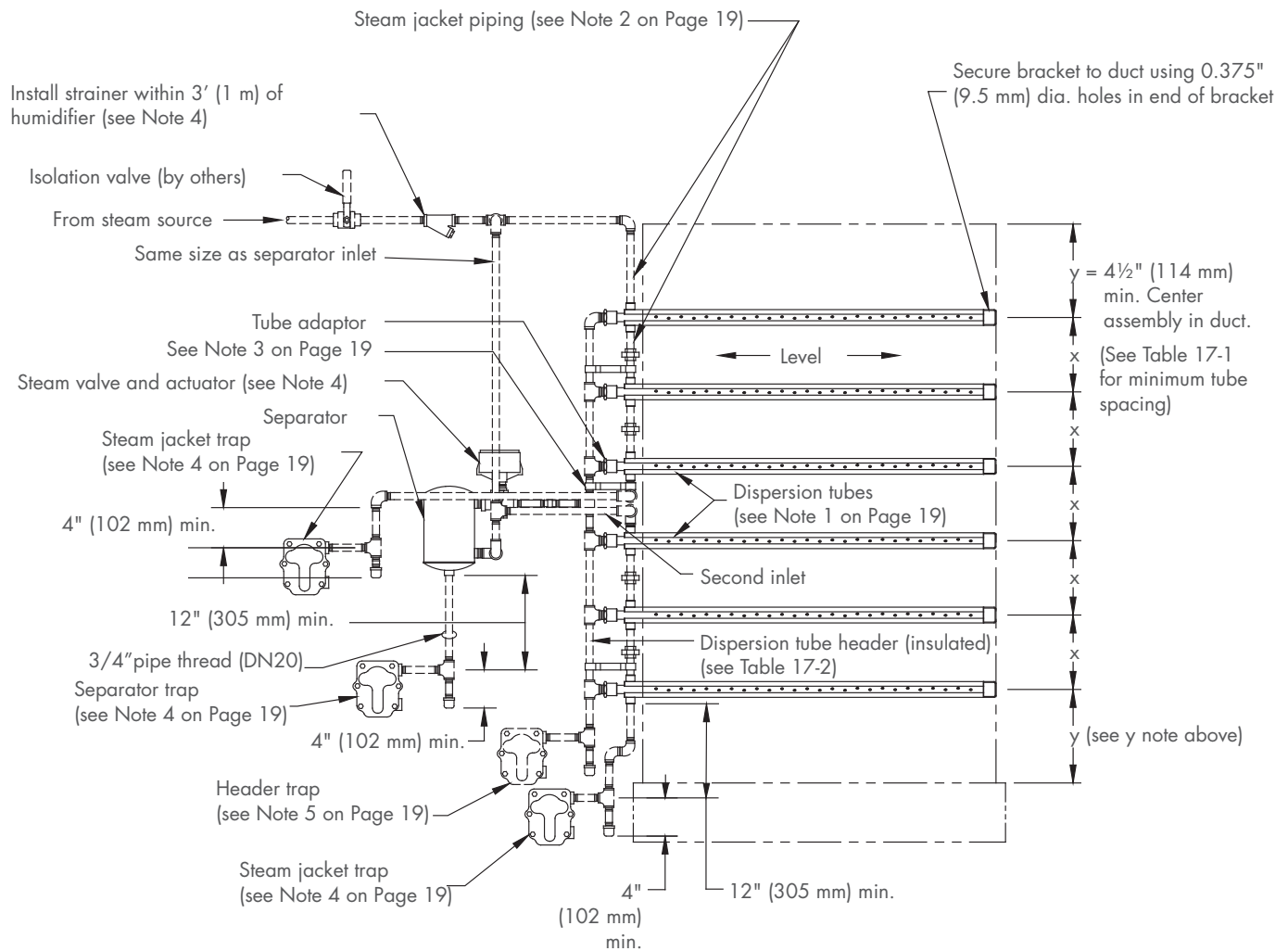

Notes:

1. To avoid metal fatigue, allow for thermal expansion of dispersion tubes.
2. Dashed lines indicate provided by installer (see Maxi-bank option in Figure 21-1). Right-hand discharge shown.
3. See the Dri-calc Installation Guide library and/or the *Steam Injection Humidifiers Installation, Operation, and Maintenance Manual* (available at www.drirsteem.com) for more installation instructions. Dri-calc is DriSteem's free sizing and selection software; see Dri-Calc on the www.drirsteem.com Tools page.
4. Steam valve and strainer sizes are provided by Dri-calc (Note 3). You may also contact your DriSteem representative for valve and strainer sizing, or access the steam valve and strainer calculator on the www.drirsteem.com Tools page.
5. See Pages 26 and 27 for more information about trap types and piping.

Multiple-tube humidifier non-wetting distances

FIGURE 22-1: MULTIPLE-TUBE HUMIDIFIER NON-WETTING DISTANCES

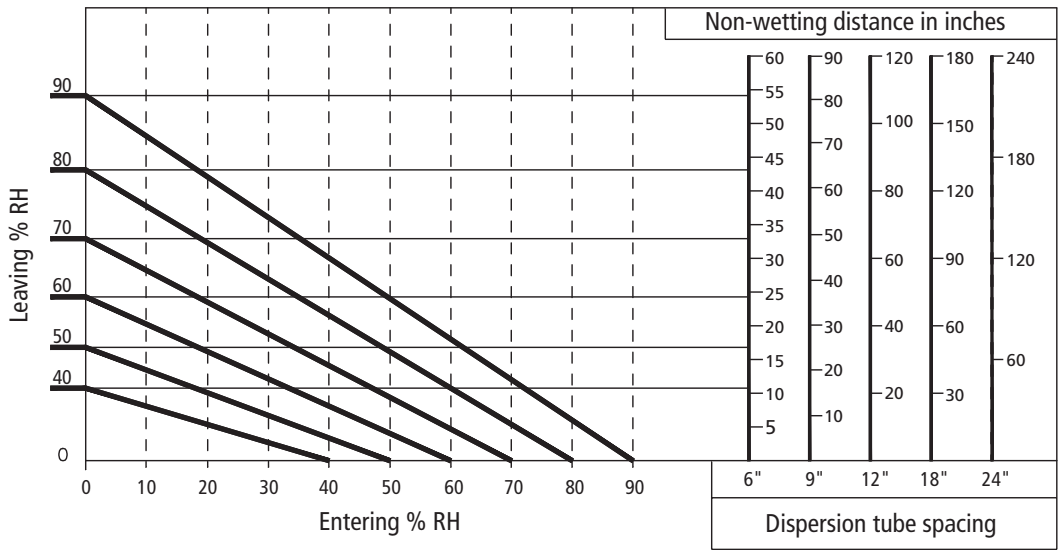

Notes:

- The above data apply to all air velocities up to 1,500 fpm (7.6 m/s), and are based on air leaving the zone of humidification at conditions of 55 °F (13 °C) and the stated % RH.
- Add 24" (610 mm) to the non-wetting distance when using insulated jackets.

DETERMINING NON-WETTING DISTANCE

See Page 11 for important notes and for instructions on using the graph above to determine non-wetting distance.

See "Steam absorption considerations" on Page 15.

The Area-type humidifier is designed for open spaces, such as warehouses and manufacturing spaces. The steam discharged from the humidifier is dispersed by the fan. The Area-type humidifier quietly distributes steam without introducing water into the air.

FIGURE 23-1: AREA-TYPE HUMIDIFIER



FIGURE 23-2: AREA-TYPE HUMIDIFIER COMPONENTS AND INSTALLATION OVERVIEW

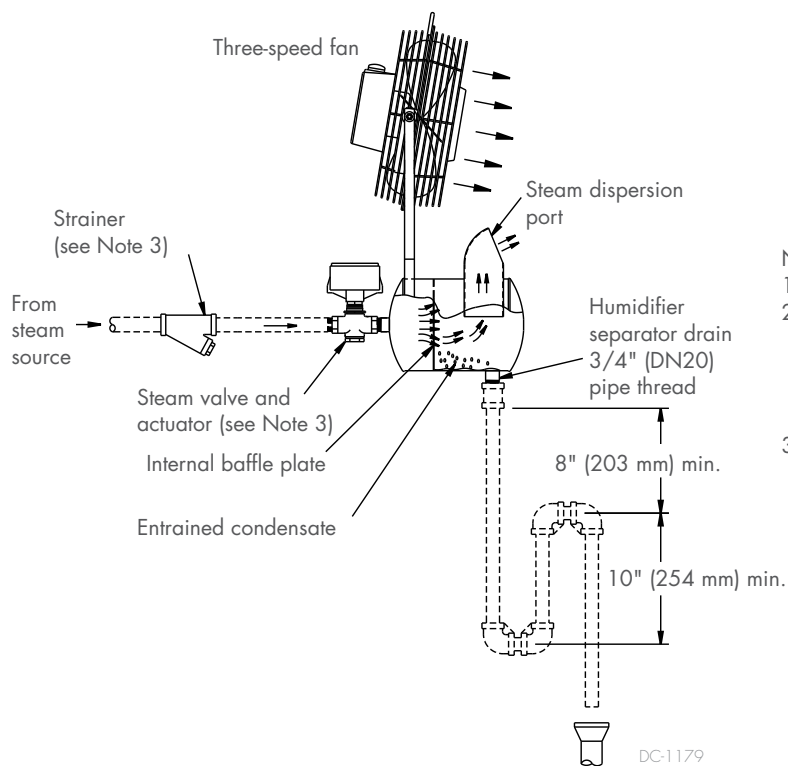

Notes:

1. Dashed lines indicate provided by installer.
2. See the Dri-calc Installation Guide library and/or the *Steam Injection Humidifiers Installation, Operation, and Maintenance Manual* (available at www.dristeem.com) for more installation instructions. Dri-calc is DriSteem's free sizing and selection software; see Dri-Calc on www.dristeem.com.
3. Steam valve and strainer sizes are provided by Dri-calc (Note 2). You may also contact your DriSteem representative for valve and strainer sizing, or access the steam valve and strainer calculator on www.dristeem.com.

Area-type humidifier rise, spread, and throw

Steam discharged from the humidifier turns into a fog that is lighter than air. Should this fog contact any solid surface before it is absorbed, it may collect as water and drip. Observe the minimum non-wetting distances for rise, spread, and throw in Table 24-1.

Table 24-1:
Rise, spread, and throw minimum non-wetting distances (nonpressurized steam)

Maximum steam capacity		60 °F (16 °C)																	
		30% RH						40% RH						50% RH					
		Rise		Spread		Throw		Rise		Spread		Throw		Rise		Spread		Throw	
lbs/hr	kg/h	ft	m	ft	m	ft	m	ft	m	ft	m	ft	m	ft	m	ft	m	ft	m
50	20	1.0	0.3	2.0	0.6	6.0	1.8	1.0	0.3	2.0	0.6	6.0	1.8	1.0	0.3	2.5	0.8	6.0	1.8
75	34	3.0	0.9	3.0	0.9	8.0	2.4	3.0	0.9	3.0	0.9	8.0	2.4	3.0	0.9	4.0	1.2	8.0	2.4
100	45	4.0	1.2	4.0	1.2	10.0	3.1	4.0	1.2	4.0	1.2	10.0	3.1	4.0	1.2	5.0	1.5	10.0	3.1
150	68	6.0	1.8	5.0	1.5	12.0	3.7	6.0	1.8	5.0	1.5	12.0	3.7	6.0	1.8	5.0	1.5	12.0	3.7
200	90	7.0	2.1	7.0	2.1	13.0	4.0	8.0	2.4	7.0	2.1	14.0	4.3	8.0	2.4	7.0	2.1	14.0	4.3
225	102	7.0	2.1	7.0	2.1	13.0	4.0	8.0	2.4	7.0	2.1	14.0	4.3	8.0	2.4	7.0	2.1	14.0	4.3
250	110	8.0	2.4	8.0	2.4	15.0	4.6	9.0	2.7	9.0	2.7	16.0	4.9	9.0	2.7	9.0	2.7	16.0	4.9
285	130	9.0	2.7	9.0	2.7	17.0	5.2	10.0	3.1	10.0	3.1	18.0	5.5	10.0	3.1	10.0	3.1	18.0	5.5
300	136	9.0	2.7	9.0	2.7	17.0	5.2	10.0	3.1	10.0	3.1	18.0	5.5	10.0	3.1	10.0	3.1	18.0	5.5
Maximum steam capacity		70 °F (16 °C)																	
		30% RH						40% RH						50% RH					
		Rise		Spread		Throw		Rise		Spread		Throw		Rise		Spread		Throw	
lbs/hr	kg/h	ft	m	ft	m	ft	m	ft	m	ft	m	ft	m	ft	m	ft	m	ft	m
50	20	1.0	0.3	1.5	0.5	4.0	1.2	1.0	0.3	2.0	0.6	4.0	1.2	1.0	0.3	2.0	0.6	4.0	1.2
75	34	2.0	0.6	2.0	0.6	6.0	1.8	2.0	0.6	2.5	0.8	6.0	1.8	2.0	0.6	2.5	0.8	6.0	1.8
100	45	3.0	0.9	3.0	0.9	8.0	2.4	3.0	0.9	3.0	0.9	8.0	2.4	3.0	0.9	3.0	0.9	8.0	2.4
150	68	4.0	1.2	4.0	1.2	10.0	3.1	4.0	1.2	4.0	1.2	11.0	3.4	4.0	1.2	4.0	1.2	11.0	3.4
200	90	5.0	1.5	5.0	1.5	11.0	3.4	5.0	1.5	5.0	1.5	12.0	3.7	5.0	1.5	5.0	1.5	12.0	3.7
225	102	5.0	1.5	5.0	1.5	11.0	3.4	5.0	1.5	5.0	1.5	12.0	3.7	5.0	1.5	5.0	1.5	12.0	3.7
250	110	6.0	1.8	6.0	1.8	12.0	3.7	6.0	1.8	6.0	1.8	13.0	4.0	6.0	1.8	6.0	1.8	14.0	4.3
285	130	7.0	2.1	7.0	2.1	14.0	4.3	7.0	2.1	7.0	2.1	15.0	4.6	7.0	2.1	7.0	2.1	16.0	4.9
300	136	7.0	2.1	7.0	2.1	14.0	4.3	7.0	2.1	7.0	2.1	15.0	4.6	7.0	2.1	7.0	2.1	16.0	4.9

FIGURE 25-1: AREA-TYPE HUMIDIFIER

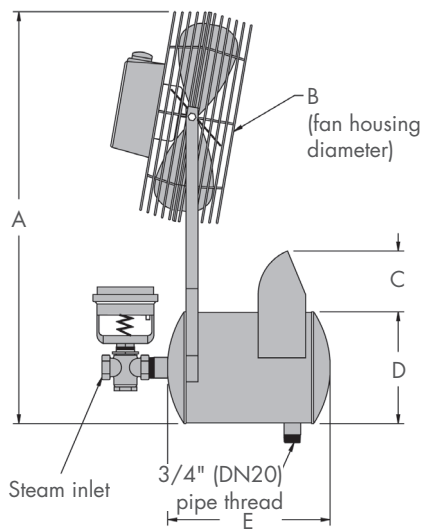

mc_041411_1847

740

Table 25-1:
Area-type humidifier dimensions

A		B		C		D		E	
inches	mm	inches	mm	inches	mm	inches	mm	inches	mm
27.0	686	14.0	357	4.8	122	7.2	183	9.5	241

mc_041411_1846

Condensate drain piping and trapping

FIGURE 26-1: CONDENSATE DRAIN PIPING AND TRAPS FOR STEAM INJECTION HUMIDIFIERS

P-TRAP DIMENSIONS

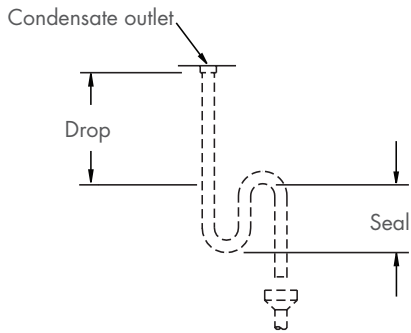

LIFTING CONDENSATE

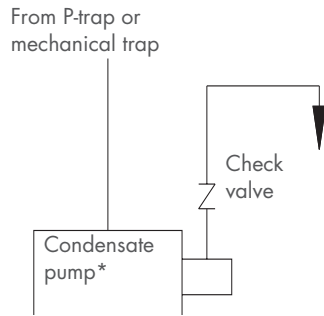

MECHANICAL TRAP DIMENSIONS

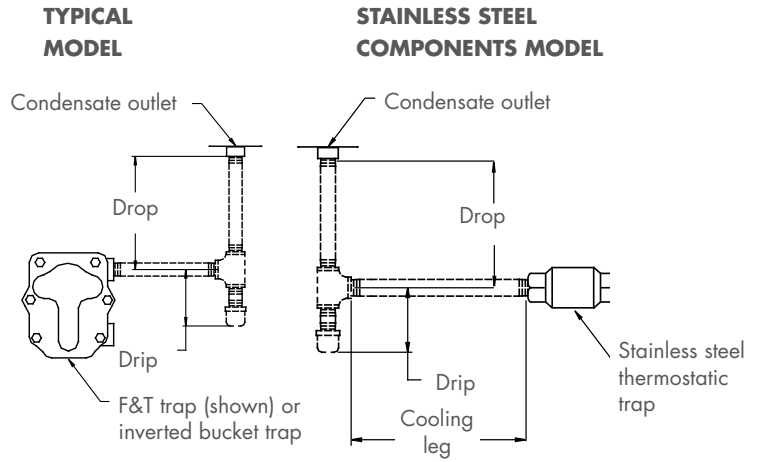

Notes:

- * Use condensate pump rated for 212 °F (100 °C) and suitable for lifting 250 gph (16 L/m) at required head (60 kPa). Stainless steel condensate pump recommended when pumping condensate from systems using optional stainless steel components.
- If wasting condensate to drain, temper condensate to local code to prevent damage to drain plumbing.
- Dashed lines indicate provided by installer.

mc_050211_1314

Table 27-1:
Condensate drain piping and traps for Steam Injection humidifiers

	Single-tube, Mini-bank, and Multiple-tube humidifiers						Area-type humidifier
	Piping from separator***		Piping from steam jackets		Piping from header		Piping from separator
	Typical model	Models with optional stainless steel components	Typical model	Models with optional stainless steel components	Typical model	Models with optional stainless steel components	
P-trap water seal	Do not use	Do not use	Do not use	Do not use	Do not use	Do not use	Use with minimum: Drop 8" (203 mm) Seal: 10" (254 mm)
F&T trap	Use if steam pressure is ≤15 psi (103.4 kPa): Drop: 12" (305 mm) Drip: 4" (102 mm)	Do not use	Use only if not lifting condensate and steam pressure is ≤15 psi (103.4 kPa): Drop: 12" (305 mm) Drip: 4" (102 mm)	Do not use	Use with minimum: Drop: 12" (305 mm) Drip: 4" (102 mm)	Do not use	Do not use
Inverted bucket trap*	Use if steam pressure is >15 psi (103.4 kPa): Drop: 12" (305 mm) Drip: 4" (102 mm)	Do not use	Use only if not lifting condensate and steam pressure is >15 psi (103.4 kPa): Drop: 12" (305 mm) Drip: 4" (102 mm)	Do not use	Do not use	Do not use	Do not use
Stainless steel thermostatic trap	Do not use	Use with stainless steel piping with minimum: Drop: 12" (305 mm) Drip: 4" (102 mm) Cooling leg: 24" (610 mm)	Do not use	Use with stainless steel piping with minimum: Drop: 12" (305 mm) Drip: 4" (102 mm) Cooling leg: 24" (610 mm)	Do not use	Use with stainless steel piping with minimum: Drop: 12" (305 mm) Drip: 4" (102 mm) Cooling leg: 24" (610 mm)	Do not use
Return condensate to boiler via nonpressurized return line?	Yes	Yes	Yes	Yes	Yes	Yes	No
Return condensate by condensate pump?	Yes	Yes**	Yes	Yes**	Yes	Yes**	Yes
Drain condensate to open drain?	Yes†	Yes†	Yes†	Yes†	Yes†	Yes†	Recommended†

Notes:

* Trap may require priming after seasonal shutdown.

** DriSteam recommends using a stainless steel condensate pump when pumping condensate from systems using optional stainless steel components.

*** During consistent load, there may not be enough steam pressure in the separator to lift condensate from the separator using steam.

† If wasting condensate to drain, temper condensate to local code to prevent damage to drain plumbing.

mc_050211_1630

DRI-STEEM Corporation

A subsidiary of Research Products Corporation
DriSteem U.S. operations are ISO 9001:2015
certified

U.S. Headquarters:
14949 Technology Drive
Eden Prairie, MN 55344
800-328-4447 or 952-949-2415
952-229-3200 (fax)

European office:
Marc Briers
Grote Hellekensstraat 54 b
B-3520 Zonhoven
Belgium
+3211823595 (voice)
+3211817948 (fax)
E-mail: marc.briers@dristeem.com

Continuous product improvement is a policy
of DriSteem Corporation; therefore, product
features and specifications are subject to
change without notice.

DriSteem, Dri-calc, Mini-bank and Vapor-logic
are registered trademarks of Research Products
Corporation and are filed for trademark
registration in Canada and the European
community.

Area-type and Maxi-bank are trademarks of
DriSteem Corporation.

Product and corporate names used in this
document may be trademarks or registered
trademarks. They are used for explanation only
without intent to infringe.

© 2015 Research Products Corporation



Form No. SI-Catalog-1114

EXPECT QUALITY FROM THE INDUSTRY LEADER

For more than 45 years, DriSteem has been leading the industry with
creative and reliable humidification solutions. Our focus on quality is
evident in the construction of DriSteem Evaporative Cooling Systems.
DriSteem leads the industry with a Two-year Limited Warranty and
optional extended warranty.

For more information
www.dristeem.com
sales@dristeem.com

For the most recent product information visit our website:
www.dristeem.com