

READ AND SAVE THESE INSTRUCTIONS

DRANE-KOOLER™

Water Tempering Device

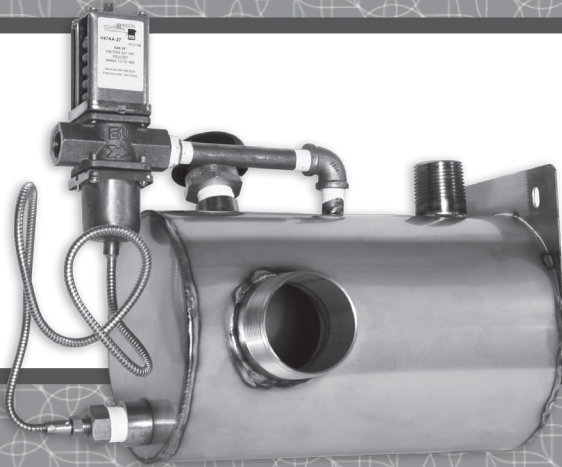

Installation, Operation,
and Maintenance Manual

Table of Contents

Overview	
Features Summary	1
Capacities and connection sizes	2
Dimensions	3
Installation	
Installation instructions	4
Mounting	5
Piping	6
Operation	
Start-up and operating instructions	7
Maintenance/Troubleshooting	
Maintenance and troubleshooting	8
Replacement parts	
Replacement parts	9
Warranty	Back cover

ATTENTION INSTALLER

Read this manual before installing.
Leave manual with product owner.

DriSteem® Corporation Technical Support

North America: 800-328-4447
Europe: +3211823595

Call us at 800-328-4447

Obtaining documents from our web site or from DriCalc is the quickest way to view our literature, or we will be happy to mail literature to you.

Download DriSteem literature

Most DriSteem product manuals are available on our website:
www.dristeem.com

 INSTALLATION AND MAINTENANCE WARNINGS
--

Attention installer

For warnings and cautions to the Drane-Kooler water tempering device, refer to the Installation, Operation, and Maintenance Manual provided with the humidifier.

Features summary

COOL DISCHARGED HOT WATER

Drane-kooler is a water tempering device that mixes cold water with hot water discharged from various types of equipment, such as a humidifier, to reduce the discharged water temperature before it enters a municipal sewer system.

There are two reasons to use a water tempering device. First, most municipalities prohibit draining water hotter than 140 °F (60 °C) into their sewer systems. And second, PVC drain pipes are susceptible to damage from water that is too hot. When faced with either of these situations, Drane-kooler is the solution!

HORIZONTAL DESIGN

A space-efficient horizontal orientation and side drain outlet provide enough clearance to allow the Drane-kooler to be mounted directly underneath DRI-STEEM humidifiers, saving footprint space while allowing room for pitched drain piping.

HOW IT WORKS: HOT + COLD = TEMPERED!

1. Hot water discharged from a humidifier or other appliance enters the Drane-kooler through piping connected to the top threaded connection. A vacuum breaker prevents backflow into potable water systems.
2. Cold water enters through the temperature-actuated valve. The valve and the Drane-kooler's straightforward design ensure efficient mixing of hot and cold water. The valve's sensor, located near the outlet, ensures that water leaving the Drane-kooler is 140 °F (60 °C) or less before entering the municipal sewer system.
3. Tempered water at 140 °F (60 °C) or less exits through the side outlet for safe discharge into a municipal sewer system or PVC pipe.

RELIABLE, NON-ELECTRIC VALVE

The temperature-actuated valve is time-tested to be reliable and maintenance-free. And because it is non-electric, no wiring is required.

MULTIPLE MOUNTING OPTIONS

The Drane-kooler can be mounted by attaching the integral mounting plate to a wall, by attaching the mounting plate to an adjustable floor stand, or by using an assembly for suspension mounting. These multiple mounting options provide capability for the Drane-kooler to be properly supported and not secured entirely by piping.

FIGURE 1-1: DRANE-KOOLER

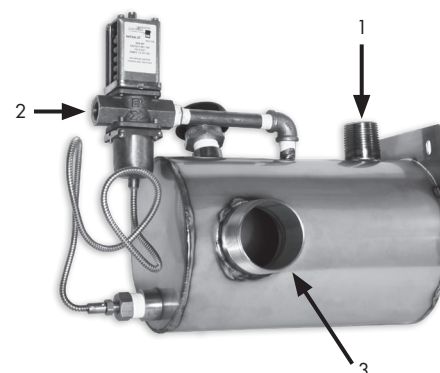

Capacities and connection sizes

FIGURE 2-1: OPTIONAL FLOOR MOUNT PIPING EXAMPLE

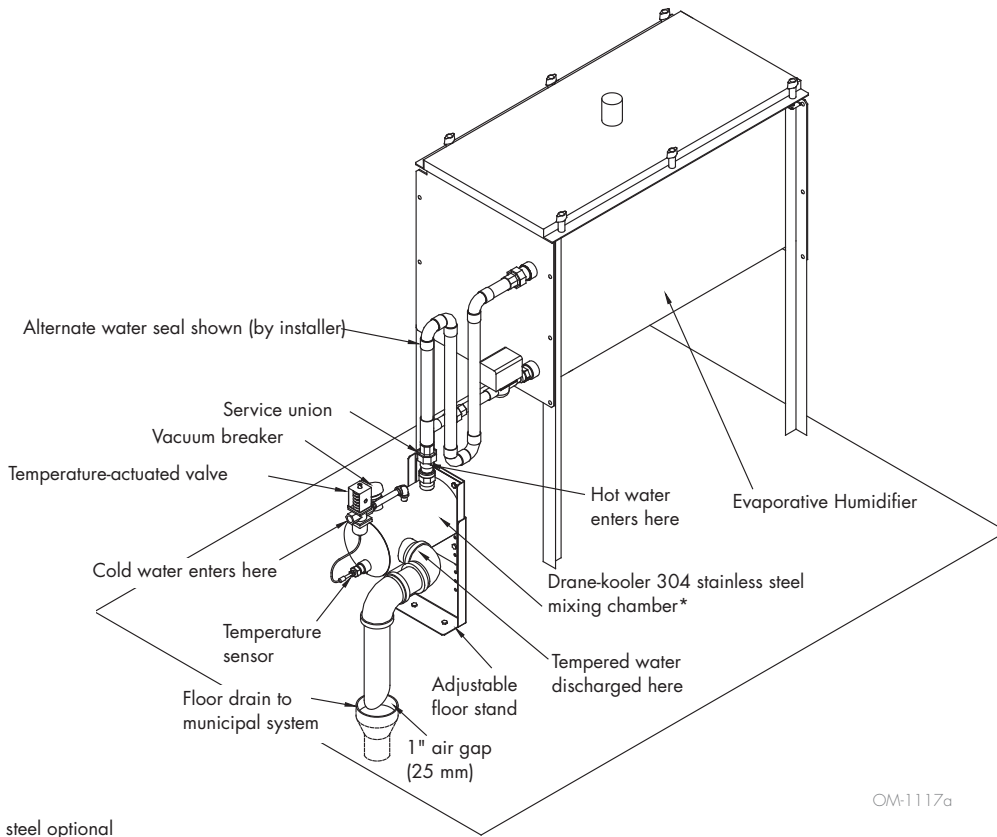

OM-1117a

*316 stainless steel optional

**Table 2-1:
Drane-kooler connections**

Hot water inlet connection	1" (DN25) pipe thread
Tempered water outlet connection	2" (DN50) pipe thread
Cold water supply connection	3/8" (DN10) pipe thread

**Table 2-2:
Drane-kooler weights**

	lbs	Kg
Shipping weight	9.5	4.3
Operating weight	15	6.8

**Table 2-3:
Drane-kooler capacities***

	Maximum flow rate		Maximum temperature	
	U.S. gpm	L/m	°F	°C
Hot water inflow	6	22.7	212	100
Cold water inflow**	6	22.7	70	21
Tempered water outflow	12	45.4	140	60

Note:

* This table applies only if one humidifier is connected to one Drane-kooler, with no more than 10' (3m) of vertical dimension between the Drane-kooler and the humidifier.

** Cold water inflow pressure must be between 25 psi and 80 psi (172 kPa and 552 kPa).

**Table 2-4:
Drane-kooler material**

Description	Material
Drane-kooler body	304 stainless steel
Optional material	316 stainless steel
Valve body	Bronze
Vacuum breaker	Brass

Dimensions

FIGURE 3-1: DRANE-KOOLER DIMENSIONS

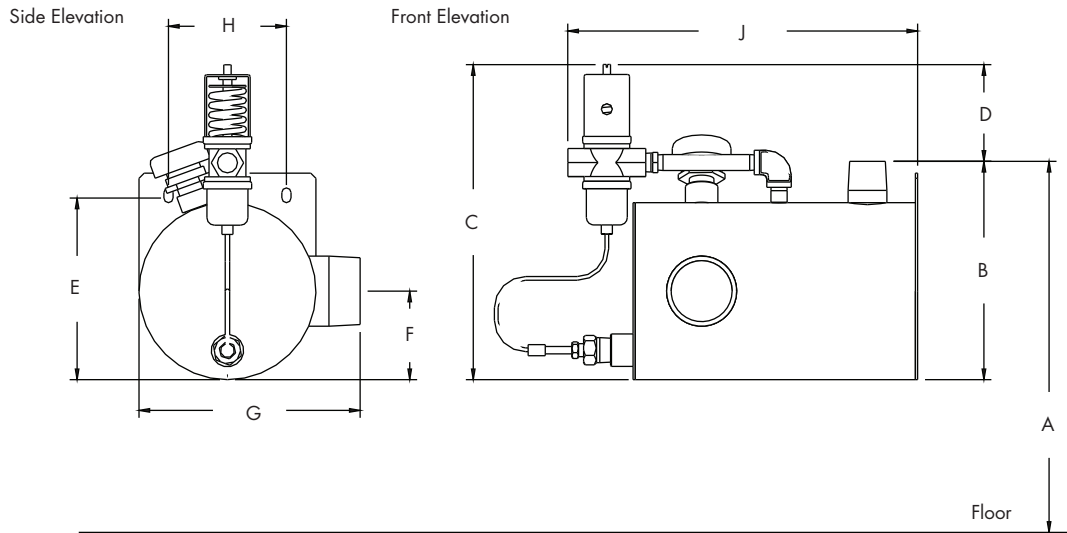

OM-1113

Table 3-1:
Drane-kooler dimensions

Item	Description	Inches (mm)
A	Height with floor stand (from floor to top of hot water inlet in 1" [25 mm] increments)	8.25 to 12.25 (210 to 312)
	Height with floor stand and extension (from floor to top of hot water inlet in 1" [25 mm] increments)	13.25 to 20.25 (337 to 515)
B	Height from bottom of tank to top of hot water inlet	7.5 (191)
C	Height from bottom of tank to top of valve	10.5 (268)
D	Height from top of hot water inlet to top of valve	3.0 (76)
E	Height from bottom of tank to center of mounting hole	6.25 (159)
F	Height from bottom of tank to center of tempered water outlet	3.0 (76)
G	Width of tank and tempered water outlet	7.5 (191)
H	Width of mounting plate holes, center to center	4.0 (102)
J	Length, from valve inlet to mounting plate	12.0 (305)

Installation locations

STEP-BY-STEP INSTALLATION INSTRUCTIONS

1. Verify that maximum flow of hot water into the Drane-kooler does not exceed 6 U.S. gallons per minute (gpm) (22.7 L/m).
2. Note that there are three connections to be made to the Drane-kooler:
 - Cold water supply
 - Hot water inlet (from a humidifier or other appliance)
 - Tempered water piping to drain
3. Position the Drane-kooler to allow the most direct path of piping to minimize fittings (see the piping diagrams on Pages 8-9).
4. Position unions on all connections as close to the Drane-kooler as possible to make cleaning and maintenance easier.
5. Cold water supply connection instructions:
 - Cold water supply connection on valve is 3/8" (DN10) pipe thread.
 - Pipe a 3/8" (DN10) line directly to the Drane-kooler from the main water supply line.
To ensure adequate water pressure to the Drane-kooler, do not connect to a supply water line that is dedicated to other appliances.
If installing the Drane-kooler with a humidifier, do not branch off the 1/4" (DN8) cold water supply line to the humidifier.
 - Verify that the supply water pressure to the valve is at least 25 psi (172 kPa) and not more than 80 psi (552 kPa).
 - Install a cold water supply union as close to the Drane-kooler as possible.
 - Install a cold water shut-off valve before the union in the cold water supply line.
6. Hot water inlet connection instructions:
 - Hot water inlet connection is 1" (DN25) pipe thread.
 - Locate a union as close to the Drane-kooler as possible
 - Run 1" (DN25) pipe as directly as possible from the hot water appliance (humidifier) to the Drane-kooler. If the piping to the hot water inlet has a horizontal run, maintain a pitch to the Drane-kooler of at least 1/8"/ft (1%).
7. Tempered water (to drain) connection instructions:
 - Tempered water outlet connection is 2" (DN50) pipe thread.
 - Install a union as close to the Drane-kooler as possible.
 - Run a 2" (DN50) pipe as directly as possible from the Drane-kooler to the drain. Maintain a pitch to drain of at least 1/8"/ft (1%).
 - Make sure there is a 1" (25 mm) air gap between the drain piping and the drain.

Mounting

THREE MOUNTING OPTIONS

Use one of the mounting options shown on this page to ensure that the Drane-kooler will be properly supported and not secured entirely by piping. Floor stand and suspension mount hanger assembly are ordered separately.

FIGURE 5-1: STANDARD WALL MOUNT

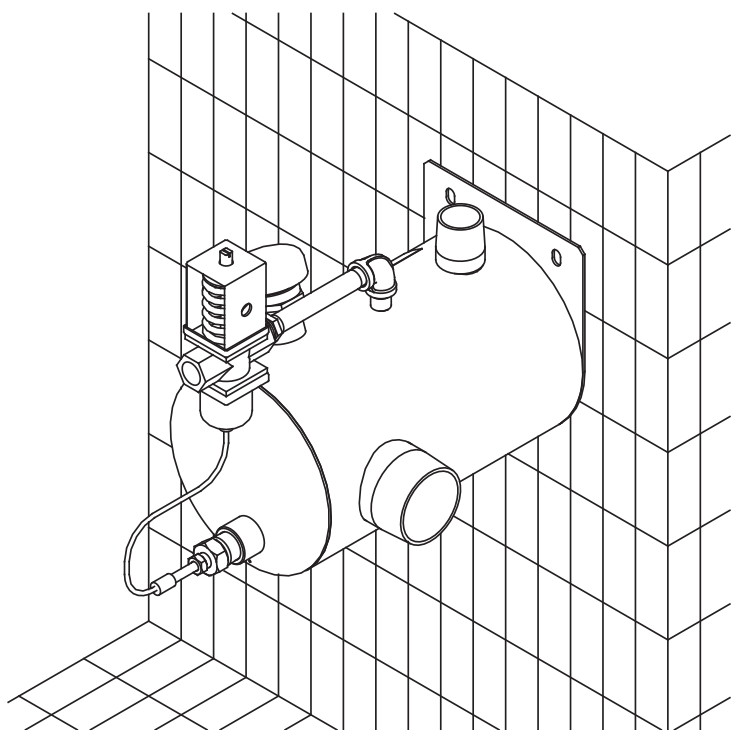

OM-1114

FIGURE 5-2: OPTIONAL SUSPENSION MOUNT

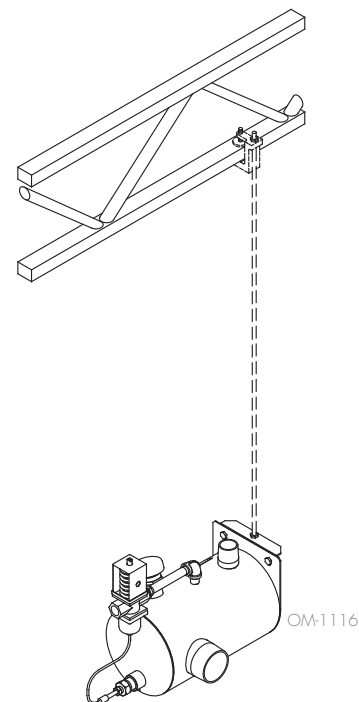

Note:

* The optional suspension mount hanger assembly includes an L-bracket, two nuts, and two bolts that attach to the Drane-kooler. Beam clamp assembly and 1/4" threaded rod are supplied by others.

FIGURE 5-3: OPTIONAL FLOOR MOUNT

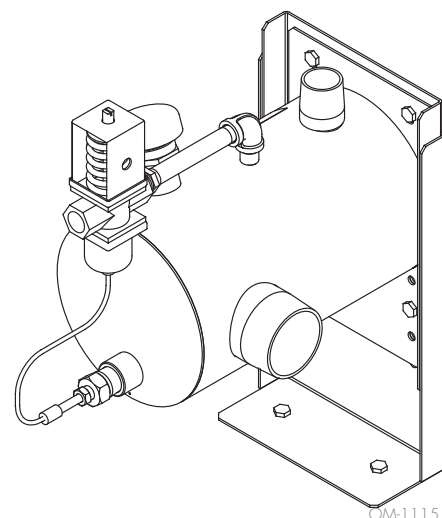

OM-1115

Piping

FIGURE 6-1: DRANE-KOOLER PIPING

Cold water supply piping:
3/8" (DN10) pipe thread
Water pressure must be between 25 psi and 80 psi (172 kPa and 552 kPa). Connect directly to the main water supply line. **To ensure adequate water pressure to the Drane-kooler, do not connect to a supply water line that is dedicated to other appliances.**

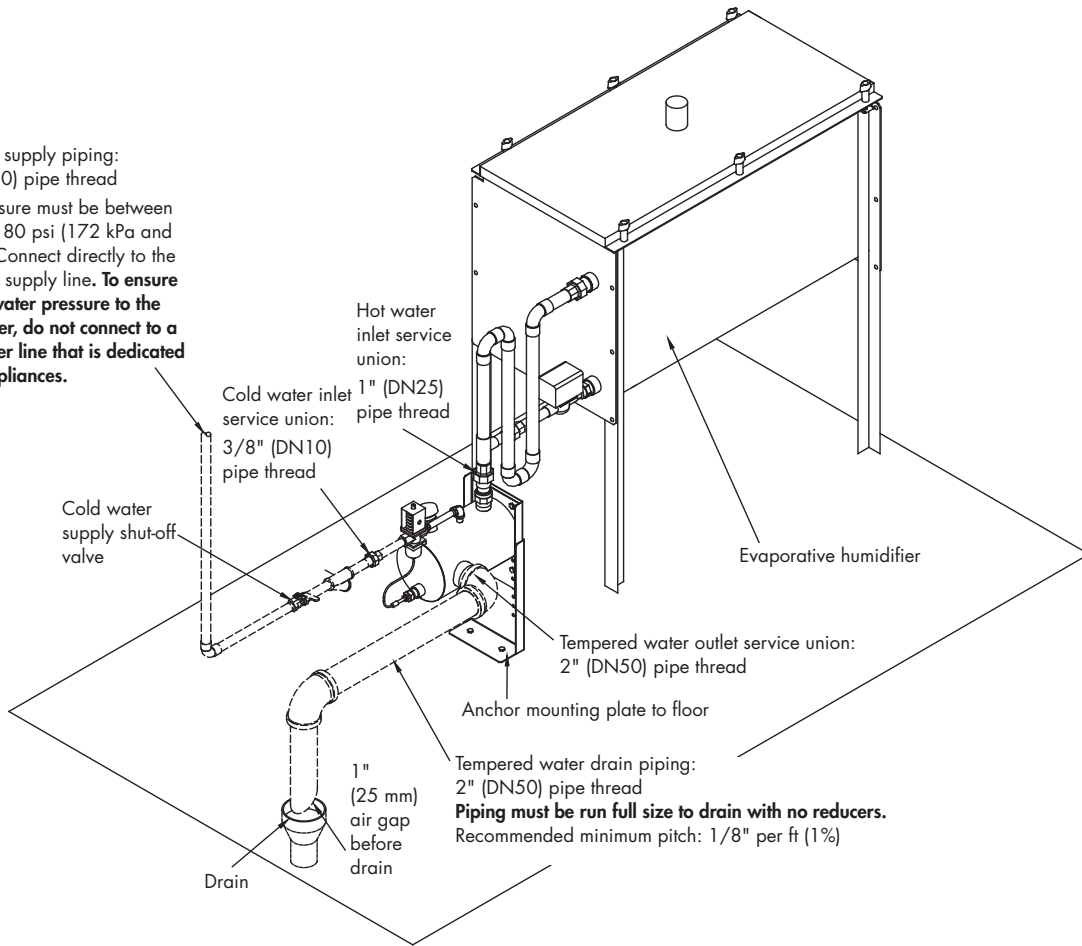

OM-1120a

FIGURE 6-2: DRANE-KOOLER MOUNTED DIRECTLY UNDERNEATH AN EVAPORATIVE HUMIDIFIER

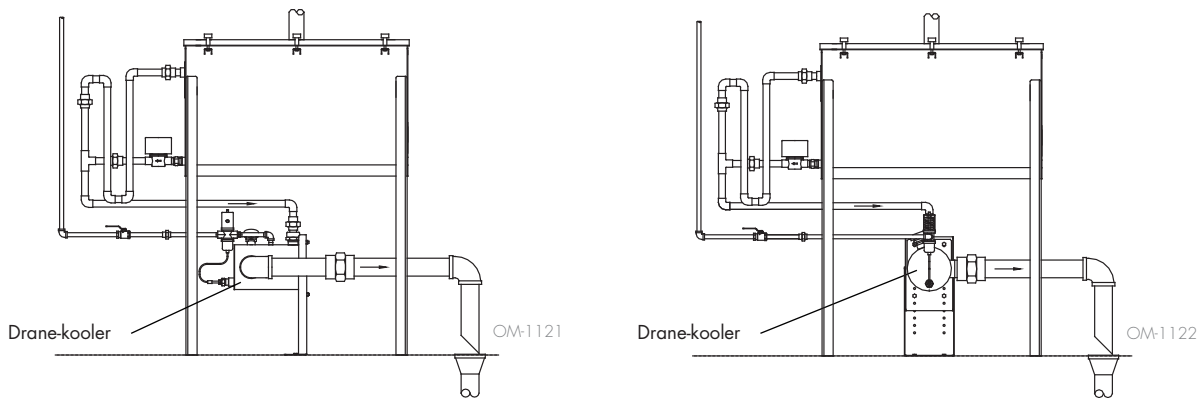

Note:
Pitch drain piping at least 1/8"/ft (1%) in direction arrows.

Start-up and operating instructions

HOW TO OPERATE

Once properly installed, to operate simply open the cold water supply line.

PRINCIPLE OF OPERATION

1. Hot water discharged from a humidifier or other appliance enters the Drane-kooler through piping connected to the top threaded connection. The vacuum breaker prevents backflow into potable water systems.
2. Cold water enters through the temperature-actuated valve. The valve and the Drane-kooler's straightforward design ensure efficient mixing of hot and cold water. The valve's sensor, located near the outlet, ensures that water leaving the Drane-kooler is less than 140 °F (60 °C)* before entering the municipal sewer system.
3. Tempered water at 140 °F (60 °C)* or less exits through the side outlet for safe discharge into a municipal sewer system or PVC pipe.

*Please see the capacities table on Page 4.

FIGURE 7-1: PRINCIPLE OF OPERATION

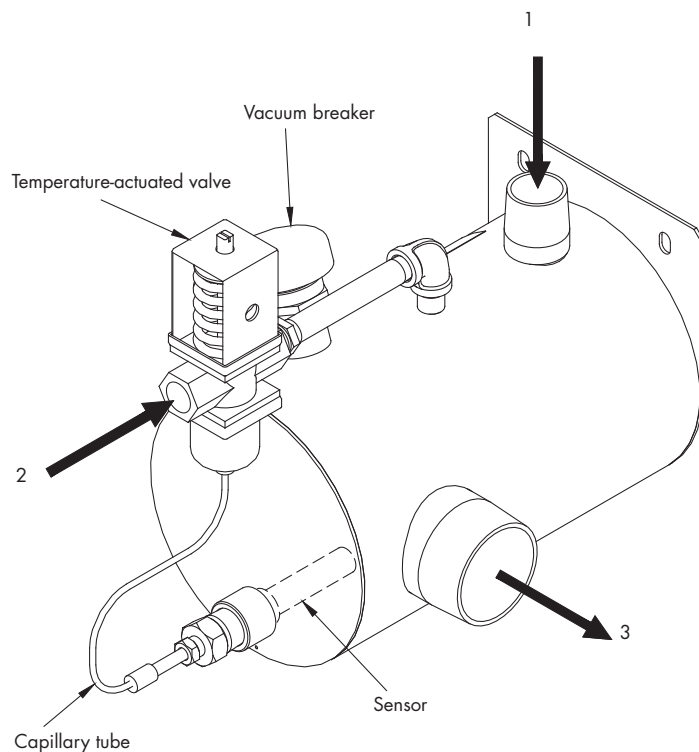

OM-1114-2

Maintenance and troubleshooting

STEP-BY-STEP MAINTENANCE INSTRUCTIONS

1. Shut off cold water supply.
2. Disconnect service unions at:
 - Cold water supply inlet
 - Hot water inlet
 - Tempered water drain outlet
3. Remove the Drane-kooler from piping and take to a service sink. Add water and, with pipe caps or hands covering the hot water inlet and tempered water outlet, shake the Drane-kooler to dislodge mineral deposits. Dump mineral deposits and rinse.
4. If severe mineral accumulation has occurred, remove the thermal sensor from the Drane-kooler chamber and gently clean the sensor with an abrasive pad. Do not twist the capillary tube during removal or cleaning.
5. Reconnect service unions and open cold water supply valve to resume operation.

Problem	Possible cause	Action
Water leaving the Drane-kooler is hotter than 140°F (60°C)	Mineral accumulation in mixing chamber	Remove the Drane-kooler and dislodge mineral accumulation.
	Mineral accumulation on thermal sensor	Remove thermal sensor from Drane-kooler and gently remove mineral accumulation with an abrasive pad. Do not twist capillary tubing during removal or cleaning.
	Valve malfunction	Valve is not working properly. Replace. Note: This valve is factory-set and should not need adjustment.
	Steam is entering the Drane-kooler	The Drane-kooler is designed to handle hot water and hot condensate. If a large amount of steam enters the Drane-kooler it is likely that discharge water temperatures will be greater than 140 °F (60 °C). Check P-traps on humidifier or other appliance to ensure that the P-traps have the proper depth and are working properly to prevent steam from entering the Drane-kooler.
Makes a loud popping or crackling noise	Steam is entering the Drane-kooler	If steam is entering the Drane-kooler, the introduction of cold water through the valve will cause the steam to collapse and make a popping or crackling sound. Check P-traps on humidifier or other appliance to ensure that the P-traps have the proper depth and are working properly.

Replacement parts

FIGURE 9-1: REPLACEMENT PARTS

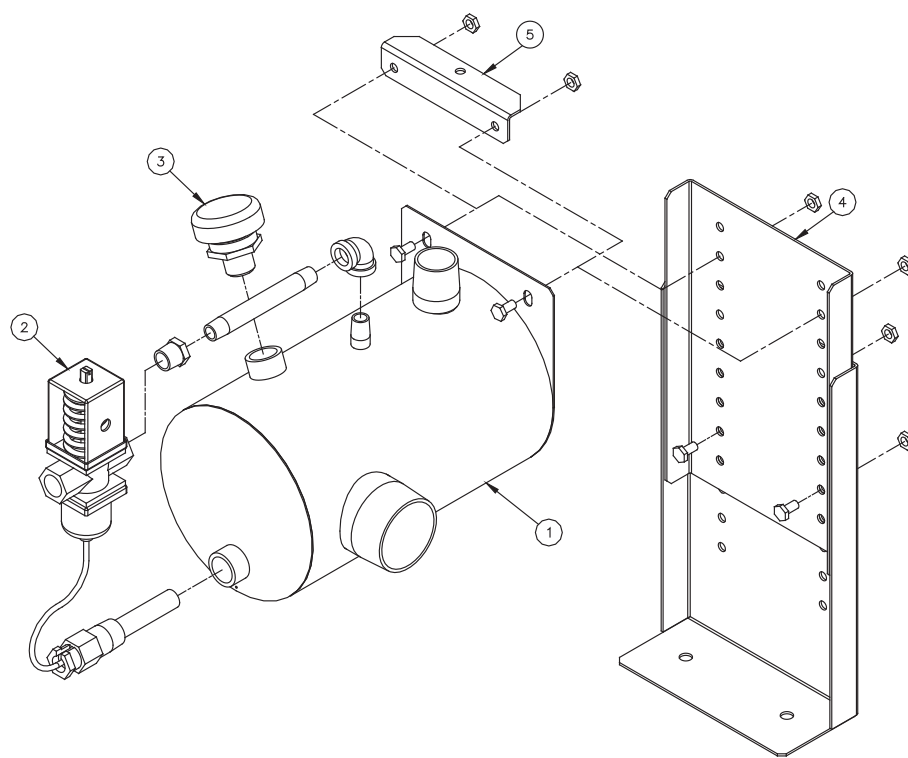

OM-1119

Table 9-1: Model DK-12 replacement parts		
Item	Description	Part Number
1	Drane-cooler weldment, Model DK-12	167001-020
2	Water tempering valve	505090
3	Valve, 1/2" N36 vacuum relief	320400
4	Floor stand assembly	185110
5	Suspension mount hanger assembly	185100

Expect quality from the industry leader

Since 1965, DriSteem has led the industry with innovative methods for humidifying and cooling air with precise control. Our focus on ease of ownership is evident in the design of the Wetted Media System. DriSteem also leads the industry with a Two-year Limited Warranty and optional extended warranty.

For more information

www.dristeem.com
sales@dristeem.com

For the most recent product information visit our website: www.dristeem.com

DRI-STEEM Corporation

a subsidiary of Research Products Corporation
DriSteem U.S. operations are ISO
9001:2015 certified

U.S. Headquarters:

14949 Technology Drive
Eden Prairie, MN 55344
800-328-4447 or 952-949-2415
952-229-3200 (fax)

European office:

Grote Hellekensstraat 54 b
B-3520 Zonhoven
Belgium
+3211823595

E-mail: dristeem-europe@dristeem.com

Continuous product improvement is a policy of DriSteem; therefore, product features and specifications are subject to change without notice.

DriSteem and Vapor-logic are registered trademarks of Research Products Corporation and are filed for trademark registration in Canada and the European community.

Product and corporate names used in this document may be trademarks or registered trademarks. They are used for explanation only without intent to infringe.

© 2014 Research Products Corporation

Form No. DK-IOM-1214
Part No. 890000-901 Rev F

TWO-YEAR LIMITED WARRANTY

DRI-STEEM Corporation ("DriSteem") warrants to the original user that its products will be free from defects in materials and workmanship for a period of two (2) years after installation or twenty-seven (27) months from the date DriSteem ships such product, whichever date is the earlier.

If any DriSteem product is found to be defective in material or workmanship during the applicable warranty period, DriSteem's entire liability, and the purchaser's sole and exclusive remedy, shall be the repair or replacement of the defective product, or the refund of the purchase price, at DriSteem's election. DriSteem shall not be liable for any costs or expenses, whether direct or indirect, associated with the installation, removal or reinstallation of any defective product. The Limited Warranty does not include cylinder replacement for electrode steam humidifiers or media replacement for Wetted Media Systems.

DriSteem's Limited Warranty shall not be effective or actionable unless there is compliance with all installation and operating instructions furnished by DriSteem, or if the products have been modified or altered without the written consent of DriSteem, or if such products have been subject to accident, misuse, mishandling, tampering, negligence or improper maintenance. Any warranty claim must be submitted to DriSteem in writing within the stated warranty period. Defective parts may be required to be returned to DriSteem.

DriSteem's Limited Warranty is made in lieu of, and DriSteem disclaims all other warranties, whether express or implied, including but not limited to any IMPLIED WARRANTY OF MERCHANTABILITY, ANY IMPLIED WARRANTY OF FITNESS FOR A PARTICULAR PURPOSE, any implied warranty arising out of a course of dealing or of performance, custom or usage of trade.

DriSteem SHALL NOT, UNDER ANY CIRCUMSTANCES BE LIABLE FOR ANY DIRECT, INDIRECT, INCIDENTAL, SPECIAL OR CONSEQUENTIAL DAMAGES (INCLUDING, BUT NOT LIMITED TO, LOSS OF PROFITS, REVENUE OR BUSINESS) OR DAMAGE OR INJURY TO PERSONS OR PROPERTY IN ANY WAY RELATED TO THE MANUFACTURE OR THE USE OF ITS PRODUCTS. The exclusion applies regardless of whether such damages are sought based on breach of warranty, breach of contract, negligence, strict liability in tort, or any other legal theory, even if DriSteem has notice of the possibility of such damages.

By purchasing DriSteem's products, the purchaser agrees to the terms and conditions of this Limited Warranty.

EXTENDED WARRANTY

The original user may extend the term of the DriSteem Limited Warranty for a limited number of months past the initial applicable warranty period and term provided in the first paragraph of this Limited Warranty. All the terms and conditions of the Limited Warranty during the initial applicable warranty period and term shall apply during any extended term. An extended warranty term of an additional twelve (12) months or twenty four (24) months of coverage may be purchased. The extended warranty term may be purchased until eighteen (18) months after the product is shipped, after which time no extended warranties are available.

Any extension of the Limited Warranty under this program must be in writing, signed by DriSteem, and paid for in full by the purchaser.

mc_051308_0630