

INSTALLATION AND MAINTENANCE GUIDE

Dolphin Blue Infrared Taps

Saving water and energy
promoting hygiene

Panel mounted electronic tap for cold or premixed water



DB/L/XL 400 DB/L/XL 425 DB 450/475

Important:

Read carefully before installing product



CONTENTS

- 3 **Technical Data**
- 4 - 5 **Pack Contents**
- 6 **Pre-Installation Information**
- 7 **Pre-Installation**
- 8 - 10 **Tap Installation DB/L/XL 400 + 425**
- 11-13 **Tap Installation DB 450 + 475**
- 14-16 **Setting Adjustment**
- 17 **Battery Replacement**
To replace the battery of DB/L/XL 400 + 450 models
- 18 **Maintenance**
Filters cleaning instructions
Care and cleaning of chrome and special finishes
- 19 **Spare Parts List**

Limited Warranty
- 20 **Trouble Shooting**

TECHNICAL DATA



Wall mounted electronic tap for cold or premixed water

Power Supply

Battery a.	6x1.5AA battery (DB/L/XL 400 models)
Battery b.	1x9V (PP3) battery (model DB 450)
Transformer	9v transformer (DB/L/XL 425 + DB 475 models)

Recommended

0.5-8.0 bar (7-116 PSI)

Water Pressure

With water pressure of more than 8 bars
use a pressure reducing valve

Sensor range

Self adjusting sensor. Adjustable with remote control

Minimum sensor range

80mm

Maximum sensor range

300mm

Security time

90 seconds. Can be changed with the DB50 remote control

Hot water temperature

Max 70°C

PACK CONTENTS

DB/L/XL 400 DB/L/XL 425

1 x Spout and attachment (inc electronic unit)

1 x Wall rosette

1 x Tap base

1 x M4x6 screw

1 x Allen key

1 x Solenoid housing
kit with filter adaptor

DB/L/XL 400

DB/L/XL 425

PACK CONTENTS

DB 450 DB 475

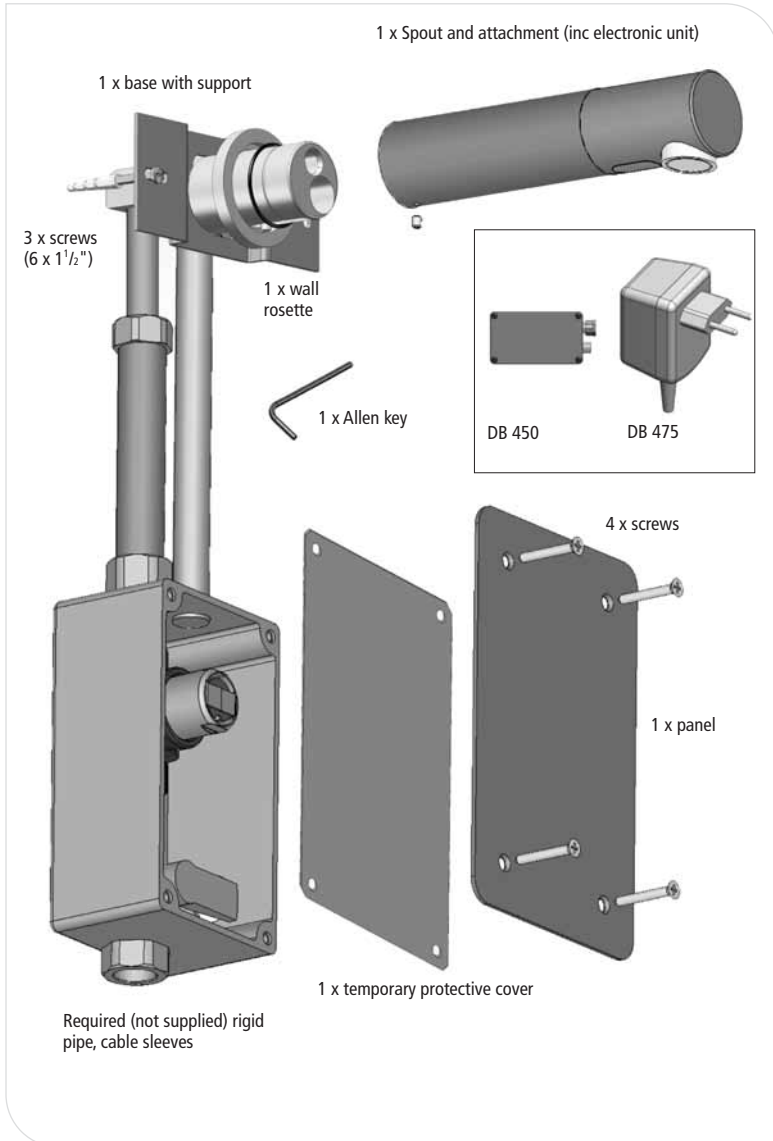

PRE INSTALLATION INFORMATION

Check Contents

Separate all parts from the packaging and check you have each part according to the pack contents section, pages 4-6. Pay attention to the variations of the different models. Make sure all parts are accounted for before discarding any packaging material.

If any parts are missing, do not attempt to install your electronic tap.

Please call 0800 0723 404 immediately to notify us.

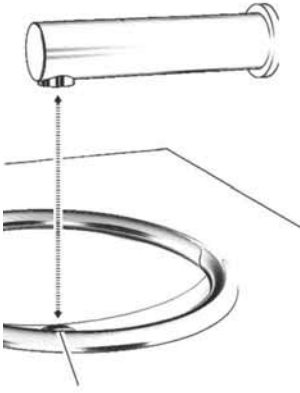

Warning

- 1) To avoid reflection problems keep a distance of more than 300 mm. between the sink and the spout.
- 2) This tap model, with an infrared sensor pointing down, is not intended to be used together with a sink of a reflective material such as stainless steel.
- 3) If a sink strainer is straight below the tap sensor, use a strainer with a non reflective finish (do not use a chrome plated one).

Preparation for installation

Flush water supply lines thoroughly before installing the tap.

Do not allow dirt, Teflon tape or metal particles to enter the tap.

Shut off water supply.

Important

All plumbing is to be installed in accordance with applicable codes and regulations.

PRE INSTALLATION

Warning

- To avoid reflection problems it is recommended to keep a distance of more than 300mm between the sink and the spout. If the distance is below 300mm a simple mock-up should be effected to confirm the tap functions as desired in your application before final installation. You may require a Dolphin Blue remote control to adjust the range.
- **Do not connect water or power supplies or remove the black label covering the infra-red sensor until you have read and understood these instructions. Please see page 13.**
- It is not recommended to use DB400 series with a polished stainless steel sink. For this type of application a separate panel-mounted sensor should be used – please speak to our technical sales team.
- Please observe the guide to minimum cavity depths as shown in the table. This is important because the water supply hose must not be kinked due to lack of space. Please note we have provided this information as a guide and cannot be held responsible for fundamental design errors. If your situation differs to those shown below please call us on 0800 0723 404, and we will provide you with a solution.

Panel thickness (A)	Minimum void (B)
10-15mm	80mm
16-25mm	70mm
26-35mm	60mm

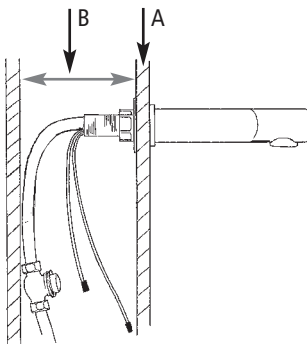

TAP INSTALLATION

Installation instructions for DB/L/XL 400 + DB/L/XL 425

Step 1 – Installing the tap

1. Shut off the water supply
2. Drill a hole (23 to 24 mm) at the place where you want to install the spout of the tap.
3. If your model includes an optional anti-rotation pin, drill a small hole just above the previous one for the anti-rotation pin.

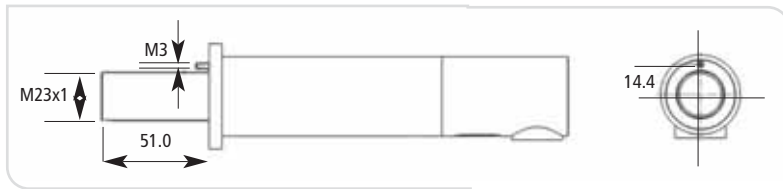

4. Insert the tap and its attachments through the wall. The aerator at the tap spout must face the washbasin.
5. Insert the anti-rotation pin into the small hole (if needed)
6. Fix the base behind the wall with the hexagonal nut and the disk.

TAP INSTALLATION

Step 2 – Connecting the Water Supply

1. Fit the flexible pipe coming from the Tap base to the solenoid valve housing.
2. Fit the water supply inlet to the adapter at the solenoid valve housing. Inlet and outlet should follow the indicating arrow at the solenoid housing.
Note: Make sure the filter is located at the solenoid inlet.
3. Connect the cable coming from the electronic unit to the solenoid valve.

Important: Tap was supplied with a Self Adjusting Sensor. The ideal sensor range for the specific location will be set automatically.

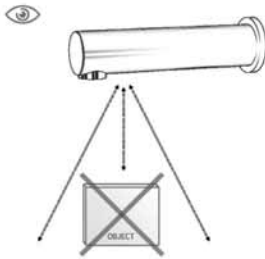
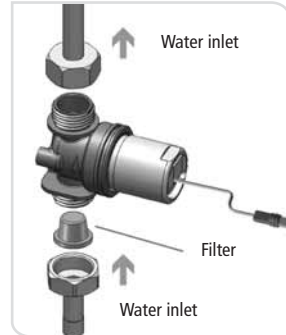

Before proceeding to step 3 check that no objects are in front of the sensor besides the washbasin.



Now, remove the protecting sticker that covers the sensor.

TAP INSTALLATION

Step 3 – Connecting the Power Source

- 1a. For DB/L/XL 400: Connect the other cable coming from the electronic unit at the Tap base to the battery box.
- 1b. For DB/L/XL 425: Connect the other cable coming from the electronic unit at the Tap base to the transformer. Plug the transformer into the electricity socket.
2. After you have connected the power source (Battery or Transformer) wait 15 seconds in order to allow the system to set the ideal sensor range.

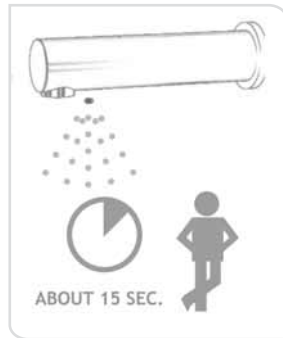

As an indication that the self adjusting is taking place, a red light in the sensor eye will flash continuously. The solenoid valve will be opened and closed for 1 second as an indication that the ideal sensor range was set and the product is ready for use.

3. Turn on the central water supply. Check for leaks.

Note: This tap includes a special aerator that allows you to adjust the water stream direction on site in order to prevent water splashing if needed. To change the angle of the water stream, simply move the adjustable tilting plate by pressing it smoothly.

4. If the automatically adjusted sensor range is not satisfactory, please refer to the section entitled "Settings adjustment".



TAP INSTALLATION

Installation instructions for DB450 and DB 475

Step 1 – Installing the Tap

1. Shut off the water supply
2. Cut an adequate opening in the wall according to the dimensions of the tap box, the cables sleeve, the rigid pipe and the tap base with the support (at the place where you want to install the spout).
3. Cut two small holes for the tap base support and drive the anchors in.
4. Insert the tap box through the wall. Connect the water supply pipe to the nipple at the bottom of the tap box.
5. Mount the tap base with the support through the wall opening, and secure the base support to the two small holes using 2 screws.
Important: The tap base should be installed so that the outside surface of the finished wall falls between the minimum and maximum lines marked at the base.
6. Assemble the rigid pipe from the nipple at the box to the inlet at the tap base.
7. Pull the wires of the power supply (transformer/battery) and sensor cable out of the tap base.
8. Lead the wires through the cable sleeve.
9. Connect the electronic unit's connector coming from the tap base to the solenoid's connector.

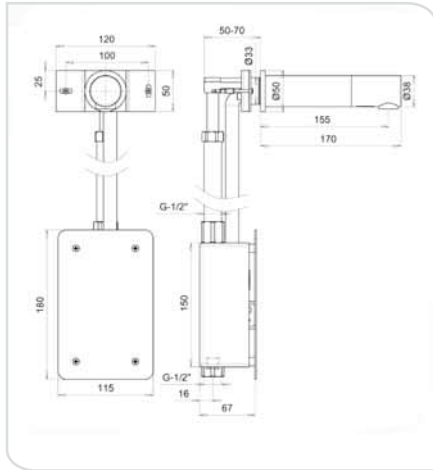

TAP INSTALLATION

10. If your model is DB 475, connect the power supply connector from the electronic unit coming from the tap base to the transformer.
11. Assemble the temporary protective cover panel to the tap box.
12. Once the works on electricity, plumbing and tiles have been finished, insert the wall rosette through the tap base.
13. Connect the cable leading to the solenoid and the power supply cable at the spout to those at the tap base. Fix the tap spout by inserting the nipple into the tap base. Make sure that this area is clean before proceeding. Secure the screw with the Allen key. Make sure that the aerator at the tap spout will be installed facing the washbasin.

Step 2 – Connecting the power source



1. Remove the temporary protective cover panel.
Important: tap was supplied with A Self Adjusting Sensor. The ideal sensor range for the specific location will be set automatically. Right now, check that no objects are in front of the sensor besides the washbasin.

2. Now remove the protecting sticker that covers the sensor.
3. If your model is DB 450 the battery box is attached to the cover panel. Connect the battery box connector to the electronic unit connector.
4. If your model is DB 475, plug the transformer into the electricity socket.



TAP INSTALLATION

5. After you have connected the power source (Battery or Transformer) wait 15 seconds in order to allow the system to set the ideal sensor range. As an indication that the self adjusting is taking place, a red light in the sensor eye will flash continuously. The solenoid valve will be opened and closed for 1 second as an indication that the ideal sensor range was set and the product is ready for use.

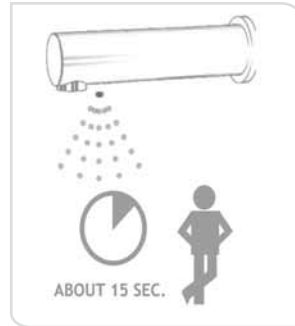

Step 3 - Connecting the water supply

1. Turn on the central water supply.
2. Check for leaks.
3. Assemble the wall cover panel by screwing the four screws.

Note: This tap includes a special aerator that allows you to adjust the water stream direction on site in order to prevent water splashing. To change the angle of the water stream, simply move the adjustable tilting plate by pressing it smoothly.

4. If the automatically adjusted sensor range is not satisfactory, please refer to the section entitled "Settings adjustment".



SETTING ADJUSTMENT

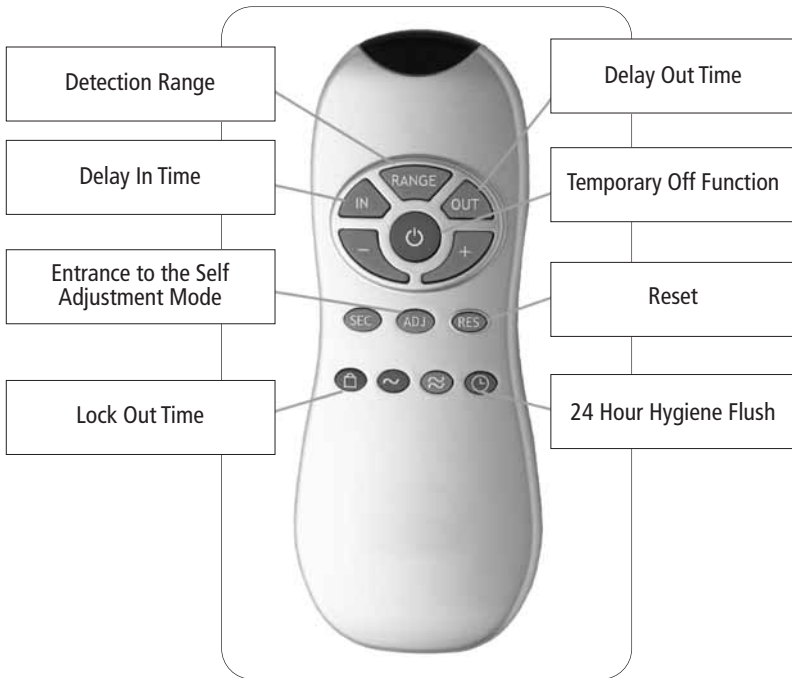

Adjusting the settings with the remote control

If necessary, the sensor settings can be adjusted as following:

Shut off the water supply. In order to adjust the sensor with the remote control, hold the remote control straight in front of the sensor in a distance of about 6-8" (15-20cm). Choose the function you want to adjust by pressing once on one of the function buttons. After pressing once on a specific function button, a quick flashing of the red light at the front of the sensor will occur. At this stage, you can change the setting by pressing the (+) or the (-) buttons, every push will increase or decrease one level. After finishing the adjustment, turn the water supply back on.

SETTING ADJUSTMENT



DETECTION RANGE: This tap was supplied with a Self Adjusting Sensor. The ideal detection range for the specific location will be set automatically.

Only if necessary, use the remote control to adjust the sensor range as follows: Press the RANGE button. Wait until a quick flashing of the red light of the sensor eye is perceived. Then, press + to increase the delay out time and – to reduce it every push will increase or decrease one level.

Note: Once you have changed the detection range with the remote control, this distance will be remembered by the sensor, even if the power source is disconnected. To get back to the self adjustment mode, use the ADJ button only.



ENTRANCE TO THE SELF ADJUSTMENT MODE: Check that no objects are in front of the sensor. Press the ADJ button. Once a quick flashing of the red light of the sensor eye is perceived, remove your hand holding the remote control and move away from the sensor area. The ideal sensor range for the specific location will be set automatically. Once the self adjustment has taken place the solenoid valve will be opened and closed for 1 second as an indication that the ideal sensor range was set and the product is ready for use.



SECURITY TIME: The Security time, prevents continuous running of water due to reflections or vandalism. By default, if the sensor is covered for more than 90 seconds the water flow will shut automatically. To resume regular operation any obstruction must be removed. Press the SEC button. Wait until a quick flashing of the red light of the sensor eye is perceived. Then, press + to increase the security time and – to reduce it.

SETTING ADJUSTMENT



DELAY IN TIME: It is recommended to change the delay in time for flush valves for urinals or toilets only.

If required, the delay in time can also be modified in taps as follows: Press the IN button. Wait until a quick flashing of the red light of the sensor eye is perceived. Then, press + to increase the delay in time and – to reduce it.



DELAY OUT TIME: This button allows modifying the water flow time after the user removes his hands from the tap. A delay out time close to 0 will save more water. An increased delay out time will make the user experience more comfortable. If required, the delay out time can be modified as follows: Press the OUT button. Wait until a quick flashing of the red light of the sensor eye is perceived. Then, press + to increase the delay out time and – to reduce it.



24 HOUR HYGIENE FLUSH: If you have a compatible model with a 24 hours hygiene flush it is possible to enable and disable it .

To activate the hygiene flush, press the clock button. Wait until a quick flashing of the red light of the sensor eye is perceived. Then press + to activate the hygiene flush or – to deactivate it.



TEMPORARY OFF FUNCTION: This function is ideal to perform any kind of activity in front of the sensor without operating the system (for example, cleaning).

The tap will remain shut for 1 minute when this button is pressed once. To cancel this function and to return to normal operation press the On/Off button again or wait 1 minute.



RESET BUTTON: This function restores all the factory settings except for the sensor range. If required, press the Reset button and without releasing it, press the + button once.

Note: To enter the self adjusting mode, use the ADJ button. To change the sensor range, use the RANGE button.

BATTERY REPLACEMENT

Battery models only

When the battery weakens, the red indicator light will blink at a constant rate when the user's hands are within the sensor range. The battery must be replaced within two weeks.



To replace the battery (battery models only):

1. For DB/L/XL 400: Open carefully the batteries' box and remove the old batteries. Replace the used batteries with six new 1.5V AA batteries. Close the box.
2. For DB 450: Release the screws at the panel and remove it. The battery box is located behind the panel. Open carefully the battery's box and replace the used battery with a new 9V battery (Lithium battery is recommended). Close the box and re-assemble the wall cover panel.

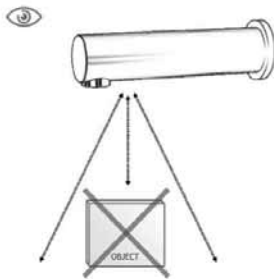
Important: Tap was supplied with A Self Adjusting Sensor. The ideal sensor range for the specific location will be set automatically again after changing the battery.



Check that there are no objects in front of the sensor after the battery replacement was completed.

After you have replaced the battery, move away from the sensor range. Wait **ABOUT 15 SEC.**   to allow the system to set the ideal sensor range. Then after the self adjustment has taken place the solenoid valve will be opened and closed for 1 second as an indication that the ideal sensor range was set and the product is ready for use.

Important: Spent batteries should not be disposed of with normal household waste. Contact your local authority for information on waste disposal and recycling.



MAINTENANCE

Filter Cleaning Instruction

This tap is provided with a stainless steel filter preventing foreign particles to enter the lines. If the water flow has decreased, this may be because the filter is clogged.

The filter can be cleaned as follows:

1. For DB/X/XL 400 + 425:
 - a. Shut-off the water shut off valve.
 - b. Disconnect the water supply pipe from the adaptor and disassemble the filter from it.
 - c. Wash the filter under running water.
 - d. Reassemble the parts.
 - e. Restore the incoming water supply.
 - f. Make sure that there is no water leakage.
2. For DB 450 + DB 475
 - a. Release the screws at the panel and remove it. Turn off the regulating valve.
 - b. Disassemble the solenoid valve by opening the nuts.
 - c. Remove the filter and wash it under running water.
 - d. Reassemble the filter.
 - e. Reassemble the solenoid valve.
 - f. Turn on the regulating valve and adjust the flow capacity.
 - g. Make sure that there is no water leakage. Re-assemble the wall cover panel.

Care and cleaning of chrome and special finishes

DO NOT use steel wool or cleansing agents containing alcohol, acid, abrasives, or the like. Use of any prohibited cleaning or maintenance products or substances could damage the surface of the tap. For surface cleaning of tap use **ONLY** soap and water, then wipe dry with clean cloth or towel. When cleaning bathroom tile, the taps should be protected from any splattering of harsh cleansers.

SPARE PARTS LIST

Self adjusting sensor kit.....	Cat.No. DB 07220056
Solenoid valve kit.....	Cat.No. DB 07230017
Solenoid housing kit for DB/L/XL 400 + 425.....	Cat.No. DB 07231008
Transformer.....	Cat.No. DB 06522042
IP67 Battery box.....	Cat.No. DB 06522020
Diaphragm.....	Cat.No. DB 04500001

Optional accessories

Remote control.....	Cat.No. DB 07100005
Battery box for 1 x 9V battery.....	Cat.No. DB 06530008
IP67 Transformer box with transformer.....	Cat.No. DB 06530021
Transformer junction box.....	Cat.No. DB 06530013
Transformer junction box exit with 3 meter cable and male connector.....	Cat.No. DB 06000084
Mixing valve.....	Cat.No. DB 200070

LIMITED WARRANTY

This product is covered by a limited warranty for two years from the date of purchase.

If a BCP product is determined by an authorised BCP technician to be defective either in materials or in workmanship, BCP will replace or cover costs for repair of the product at its own discretion. If replacement or repair is not feasible, BCP will refund the original purchase price of the product.

This warranty does not cover products that have not been installed in accordance with BCP's installation guide, or products that have been damaged through abuse, misuse, misapplication, wear and tear and battery or water compositions. This includes (but is not limited to) the following:

- Incorrect installation, inversions of supply pipes.
- Pressures or temperatures exceeding recommended limits.
- Improper manipulations, tampering, bad or lapsed maintenance.
- Foreign bodies, dirt or scale introduced by the water supply.

TROUBLE SHOOTING

PROBLEM	INDICATOR	CAUSE	SOLUTION
No water coming out of the tap	1. Sensor flashes continuously when user's hands are within the sensor's range 2. Red light in the sensor does not flash when user's hands are within the sensor's range	Low battery	Replace battery
		1 Range is too short	Increase the range
		2 Range is too long	Decrease the range
		3 Battery is completely used up	The battery must be replaced
		4 Unit is in 'security mode'*	
	3 Red light in the sensor flashes when user's hands are within the sensor's range	5 Sensor is picking up reflections from the washbasin or other objects	Eliminate cause of reflection
		1 Connectors between the electronic unit and solenoid are disconnected	Connect the electronic unit connectors to the solenoid
		2 Debris or scale in solenoid	Unscrew solenoid, pull out the plunger and the spring from the solenoid and clean them. Use scale remover material if needed. When replacing the plunger, please make sure the spring is in the vertical position.
		3 The central orifice in the diaphragm is plugged or the diaphragm is torn	Clean the orifice or replace diaphragm
		4 The water supply pressure is higher than 8 bar	Reduce the supply water pressure
Water flow from spout does not stop	1 Sensor flashes when user's hands are within the sensor's range	Debris or scale in diaphragm	Clean the orifice or replace diaphragm
	2 Red light in the sensor does not flash when user's hands are within the sensor's range	1 Sensor is dirty or covered	Clean or eliminate cause of interference
		2 Sensor is picking up reflections from the washbasin or another object	Decrease the range or eliminate cause of reflection
Water flow diminished		Filter or aerator clogged	Remove, clean or re-install

*'Security mode': If the sensor is covered for longer than the specified security time, the tap will automatically shut off water flow. To return to normal operation remove any blockage to re-establish operation



Request your 320 page
catalogue today on
0800 0723 404

Bell-Chem Products Company
Haywood Way, Hastings TN35 4PL

Tel: +44 (0)1424 202224
Fax: +44 (0)1424 205 200
info@dolphindispensers.co.uk
www.dolphindispensers.co.uk