

INSTALLATION AND MAINTENANCE GUIDE

Infrared Taps

Electronic taps – saving water,
saving power, promoting hygiene



DB100
DB125
DB150
DB175



DBL200
DBL225
DBL250
DBL275



DB200
DB225
DB250
DB275

Important:

Read carefully
before installing
product



INDEX

- 3 **Technical Data : battery powered taps**
- 4 **Technical Data : transformer powered taps**
- 5 **Pack Contents**
- 6 **Pre Installation Information**
- 7 - 9 **Tap Installation**
- 10-11 **Range Adjustment using Dolphin Blue Remote Control – DB51**
 Adjusting the sensor range with a remote control
- 12 **Battery Replacement**
 DB100, DB150, DB200, DB250, DBL200, DBL250 models
- 13 **Maintenance**
 Filters cleaning instructions
 Care and cleaning of chrome and special finishes
- 14 **Trouble Shooting**
- 15 **Spare Parts List**
- 16 **Warranty**

TECHNICAL DATA

Technical details for BATTERY powered taps

Power Supply	9V (1 x 9v PP3)
Security Time	90 seconds. Can be reduced with the remote control
Recommended Water Pressure	0.5-8.0 bar (7-116 PSI) With water pressure of more than 8 bars use a pressure reducing valve for reduction
Preset sensor range	220mm
Minimum sensor range	80mm
Maximum sensor range	300mm
Hot water temperature	Max 70°C

TECHNICAL DATA

Technical details for TRANSFORMER powered taps

Power Supply	9V Transformer
Security Time	90 seconds. Can be reduced with the remote control
Recommended Water Pressure	0.5-8.0 bar (7-116 PSI) With water pressure of more than 8 bars use a pressure reducing valve for reduction
Preset sensor range	220mm
Minimum sensor range	80mm
Maximum sensor range	300mm
Hot water temperature	Max 70°C

PACK CONTENTS

Familiarise yourself with the part's names and confirm that the parts are included.

DB100

DB200

DBL200

1 1 x tap and attachment

2 1 x filter

3 1 x battery box

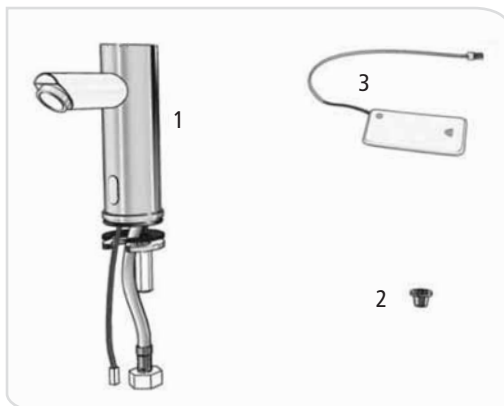

DB125

DB225

DBL225

1 1 x tap and attachment

2 1 x filter

3 1 x transformer

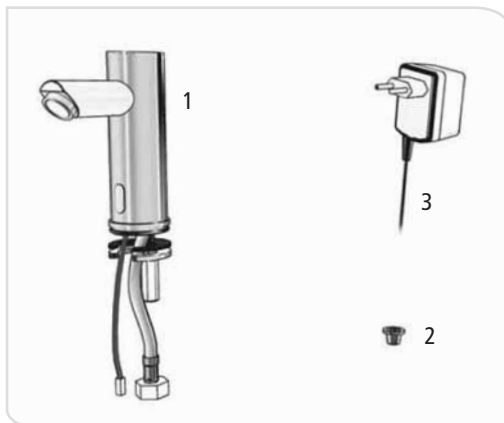

PRE INSTALLATION INFORMATION

Check contents

- Separate all parts from the packaging and check each part with the 'pack contents' section.
- Pay attention to the different model variations.
- Make sure all parts are accounted for before discarding any packaging material.
- If any parts are missing, do not attempt to install your electronic tap until you obtain the missing parts.

Warnings

- Do not install facing a mirror or any other electronic system operated by an infrared sensor.
- To prevent reflection problems, it is recommended to keep a minimum distance of 1.5 metres between the tap and any other objects.

Preparation for installation

- Flush water supply lines thoroughly before installing the tap.
- Do not allow dirt, Teflon tape or metal particles to enter the tap.
- Shut off the water supply.

Important

- All plumbing is to be installed in accordance with applicable codes and regulations.
- Installations in Australia and New Zealand must comply with the requirements of AS/NZS 3500

Recommended hole size

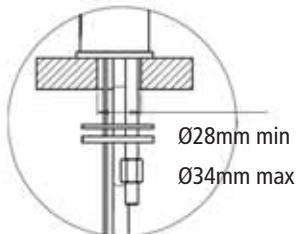

Standard versions

Recommended hole size

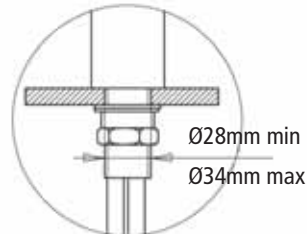

Tall versions

TAP INSTALLATION

Familiarise yourself with the part's names and confirm that the parts are included.

DB150

DB250

DBL250

1 1 x tap and attachments

2 2 x filters

3 1 x battery box

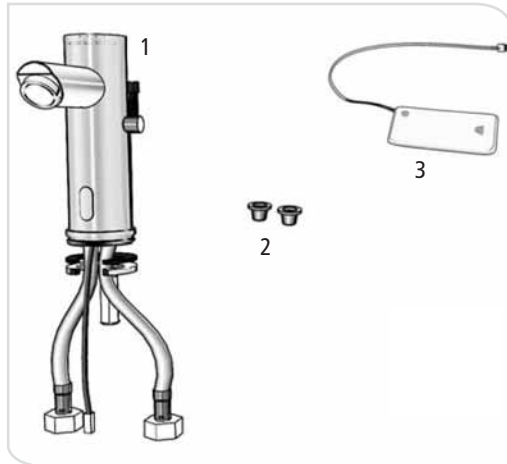

DB175

DB275

DBL275

1 1 x tap and attachments

2 2 x filters

3 1 x transformer

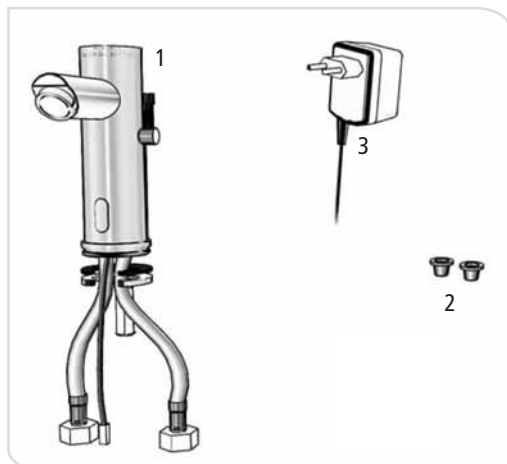

TAP INSTALLATION

Step 1 – Remove all mounting hardware

1 Shut off water supply and remove the hexagonal nut, the disk

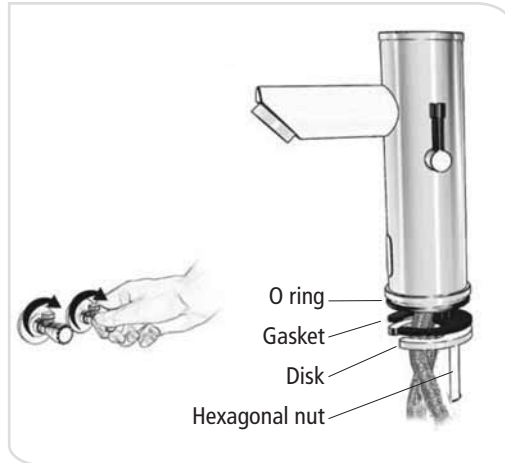

Step 2 – Installing the tap

1 Place the tap with O-ring into the hole in the basin or basin/sink. Make sure the O-ring is located between the counter or basin/sink and the bottom of the tap.

2. Slide the gasket over flexible hose(s).

3. Secure the tap to the counter or basin/sink with the hexagonal nut and the disk.

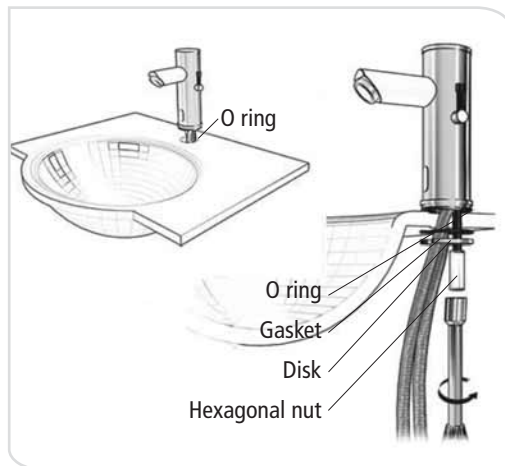

TAP INSTALLATION

Step 3 – Connecting the Water Source

- a. DB100, DB125, DB200, DB225, DBL200, DBL225: connect the flexible pipe to the water supply
b. DB150, DB175, DB250, DB275, DBL250, DBL275: connect the red flexible pipe to the hot water supply and the blue flexible pipe to the cold water supply.
- Make sure the filter(s) are installed between the flexible pipe and the shut off valve (not supplied).
- Turn on the central water supply and the shut off valve.
- Check for leaks.

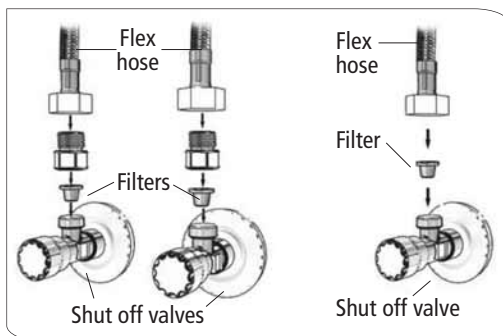

Step 4 Connecting the Power Source

- a. DB100, DB150, DB200, DB250, DBL200, DBL250: connect the power source, Install the battery's box at the wall under the sink using the two sided adhesive foam tape. The cable connection must point down. (You can use an optional extension cable in order to assemble the battery box up to ten feet from the sink. See "Spare parts list").
b. DB125, DB175, DB225, DB275, DBL225, DBL275: plug the transformer into the electrical socket and connect the connectors.
- Important:** Wait a few seconds before activating the tap to avoid entering into 'adjustment mode'.
- If range is unsatisfactory, refer to the section entitled 'Range adjustment'.

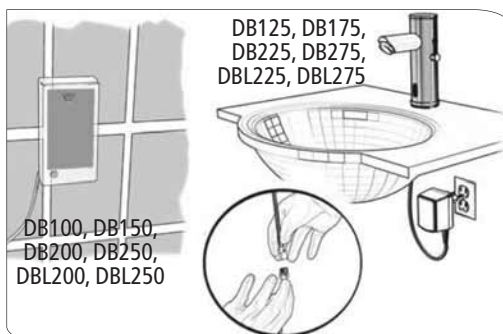

RANGE ADJUSTMENT

Adjusting the sensor with the remote control

This tap was supplied with a Self Adjusting Sensor. The ideal detection range for the specific location will be set automatically.



DETECTION RANGE: Only if necessary, use the remote control to adjust the sensor range as follows: Shut off the water supply. Hold the remote control straight in front of the sensor in a distance of about 6 - 8" (15 - 20cm). Choose the function RANGE by pressing once at the range function button. After pressing this function button, a quick flashing of the red light at the front of the sensor will occur. At this stage, you can increase or decrease the sensor range by pressing the (+) or the (-) buttons, every push will increase or decrease one level.

Note: Once you have changed the detection range with the remote control, this distance will be remembered by the sensor, even if the power source is disconnected. To get back to the self adjustment mode, use the ADJ button only.

Adjusting other settings with the remote control



SECURITY TIME: The Security time, prevents continuous running of water due to reflections or vandalism. By default, if the sensor is covered for more than 90 seconds the water flow will shut automatically. To resume regular operation any obstruction must be removed.

Press the SEC button. Wait until a quick flashing of the red light of the sensor eye is perceived. Then, press + to increase the security time and – to reduce it.



DELAY IN TIME: It is recommended to change the delay in time for flush valves for urinals or toilets only.

If required, the delay in time can also be modified in taps as follows: Press the IN button. Wait until a quick flashing of the red light of the sensor eye is perceived. Then, press + to increase the delay in time and – to reduce it.

RANGE ADJUSTMENT



DELAY OUT TIME: This button allows modifying the water flow time after the user removes his hands from the tap. A delay out time close to 0 will save more water. An increased delay out time will make the user experience more comfortable. The factory setting for delay out time is 1 second. If required, the delay out time can be modified as follows: Press the OUT button. Wait until a quick flashing of the red light of the sensor eye is perceived. Then, press + to increase the delay out time and – to reduce it.



24 HOUR HYGIENE FLUSH: If you have a compatible model with a 24 hours hygiene flush it is possible to enable and disable it. To activate the hygiene flush, press the clock button. Wait until a quick flashing of the red light of the sensor eye is perceived. Then press + to activate the hygiene flush or – to deactivate it.



TEMPORARY OFF FUNCTION: This function is ideal to perform any kind of activity in front of the sensor without operating the system (for example, cleaning). The tap will remain shut for 1 minute when this button is pressed once. To cancel this function and to return to normal operation press the On/Off button again or wait 1 minute.



RESET BUTTON: This function restores all the factory settings except for the sensor range. If required, press the Reset button and without releasing it, press the + button once.

Note: To enter the self adjusting mode, use the ADJ button. To change the sensor range, use the RANGE button.

BATTERY REPLACEMENT

For models DB100, DB150, DB200, DB250, DBL200, DBL250

Battery models only

When the battery weakens, the red indicator light will blink at a constant rate. The battery must be replaced within two weeks.

To replace the battery

- 1 Carefully open the battery's box
- 2 Remove the old battery
- 3 Replace the used battery with a new 9V battery (Lithium battery is recommended)
- 4 Close the box

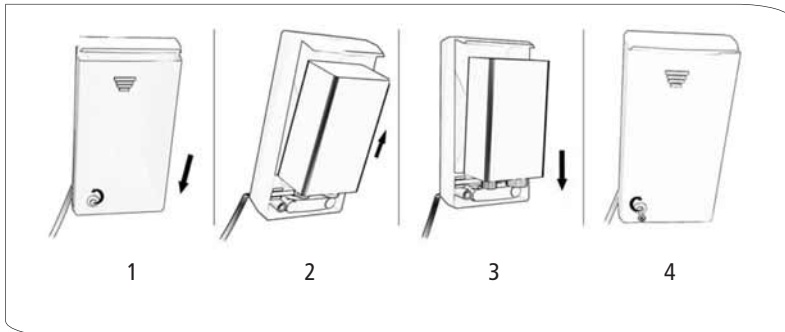

MAINTENANCE

Filter Cleaning Instruction

This tap is provided with one/two stainless steel filter(s) preventing foreign particles to enter the lines. If the water flow has decreased, this may be because the filter(s) is/are clogged. The filter(s) can be changed as follows:

- 1 Shut off the water shut-off valve

For DB100, DB125, DB200, DB225, DBL200, DBL225

- 2 Disconnect the flexible pipe

For DB150, DB175, DB250, DB275, DBL250, DBL275

- 2 Disconnect the red and blue flexible pipes
- 3 Remove the filter(s) and wash it/them under running water
- 4 Reassemble the parts.
- 5 Reconnect the flexible pipe(s) and restore the incoming water supply.
- 6 Make sure that there is no water leakage.

Care and cleansing of chrome and special features

DO NOT use steel wool or cleansing agents containing alcohol, acid, abrasives, or the like. Use of any prohibited cleansing or maintenance products or substances could damage the surface of the tap. For surface cleansing of the tap use only soap and water, then wipe dry with clean cloth or towel. When cleaning bathroom tiles, the tap should be protected from any splattering of harsh cleansers.

TROUBLE SHOOTING

PROBLEM	INDICATOR	CAUSE	SOLUTION
No water comes out of the tap	Sensor flashes continuously when user's hands are within the sensor's range	Low batteries	Replace batteries
		Range is too short	Increase the range with remote
		Range is too long ie tap has gone into security mode	Decrease the range with remote
		Batteries are completely used up	Replace batteries
	Red light in the sensor does not flash once when user's hands are within the sensor's range	Sensor is picking up reflections ie tap has gone into security mode	Decrease the range or eliminate cause of reflection
		Connectors between the electronic unit and the solenoid are disconnected	Connect the electronic unit connectors to the solenoid
		Debris or scale in solenoid	Unscrew solenoid, pull out the plunger and the spring from the solenoid and clean them. Use scale remover material if needed. When replacing the plunger, please make sure that the spring is in vertical position
		The central orifice in the diaphragm is plugged or the diaphragm is torn	Unscrew solenoid and clean the orifice and/or replace diaphragm
		The water supply pressure is higher than 8 bars	Reduce the water supply pressure
Water flow from spout does not stop	Sensor flashes once when user's hands are within the sensor's range	Debris or scale in diaphragm	Unscrew solenoid, remove diaphragm and clean or replace. Use scale remover if needed.
	Red light in the sensor does not flash when user's hands are within the sensor's range	Sensor is dirty or covered	Clean or eliminate cause of interference
		Sensor is picking up reflections from the washbasin or another object	Decrease the range or eliminate cause of reflection
Water flow diminished		Filter or aerator is clogged	Remove, clean and reinstall

SPARE PARTS LIST

1	Sensor kit DB 100 range	Cat No. DB 07220184
	DB 200 range	Cat No. DB 07220183
2	Solenoid valve kit	Cat No. DB 07230003
3	Filter adapter kit	Cat No. DB 07212001
4	Battery Box	Cat No. DB 06530018
5	Transformer	Cat No. DB 06522046

Optional accessories

6	Extension cable	Cat No. DB 06009015
7	Remote control	Cat No. DB 51
8	Mixing Valve	Cat No. DB 60
9	IP67 Battery Box	Cat No. DB 06530019
10	Transformer junction box	Cat No. DB 06530013

LIMITED WARRANTY

This product is covered by a limited warranty for two years from date of purchase.

During this period, Bell-Chem Products Co. undertakes, at its option, to repair or replace any faults caused by defective materials or manufacturer defaults that may arise.

The guarantee does not cover faults or damage caused by incorrect installation and/or manufacture, wear and tear, battery or water compositions. This includes but is not limited to the following:

- incorrect installation, inversions or supply pipes
- Pressures or temperatures exceeding recommended limits
- Improper manipulations, tampering, bad or lapsed maintenance
- Foreign bodies, dirt or scale introduced by the water supply



Request your 320 page
catalogue today on
0800 0723 404

Bell-Chem Products Company
Haywood Way, Hastings TN35 4PL

Tel: +44 (0)1424 202224
Fax: +44 (0)1424 205 200
info@dolphindispensers.co.uk
www.dolphindispensers.co.uk